



Modelo movimentação

EMPILHADEIRA (*FORKLIFT*)

FORKLIFT SIMULATION

THE DIFFERENT TASKS OF THE FORKLIFT ARE PROGRAMMED IN THIS EXAMPLE IN THE SENSOR CONTROLS OF THE TRACKS.

TRAINING-ID: 579 – [HTTPS://WWW.BANGSOW.EU/DETAIL_EN.PHP?ID=579](https://www.bangsow.eu/detail_en.php?id=579)


Tecnomatix Plant Simulation

_ Simulation Modeling and Programming by Means of Examples

Steffen Bangsow

6.10.2 Simulation of a Forklift

Exercício página 357

You are intended to simulate the loading and unloading of presses. The forklift takes from the loading location of the press an empty pallet and loads the press with a plate stack. The forklift brings the empty plate pallet to an empty containers warehouse. The finished product is stacked by a worker in racks. The forklift has to pick up the loaded racks and supply empty racks. Create a frame according to . To fulfill all the jobs, four different routes are necessary. They begin on the waiting point of the forklift (buffer) and end up there again. Insert the routes as follows:

Modelos

Operação



Descrição



Exemplo: produção



Dicas



Movimentação

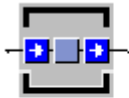


CRANE



Modelo Bruno Natália Rainne





Empilhadeira_WIP

Empilhadeira

.Models.Frame.Empilhadeira_WIP ? X

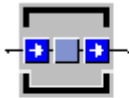
Navigate View Tools Help

Name: Empilhadeira_WIP Failed Entrance locked

Label: Planned Exit locked

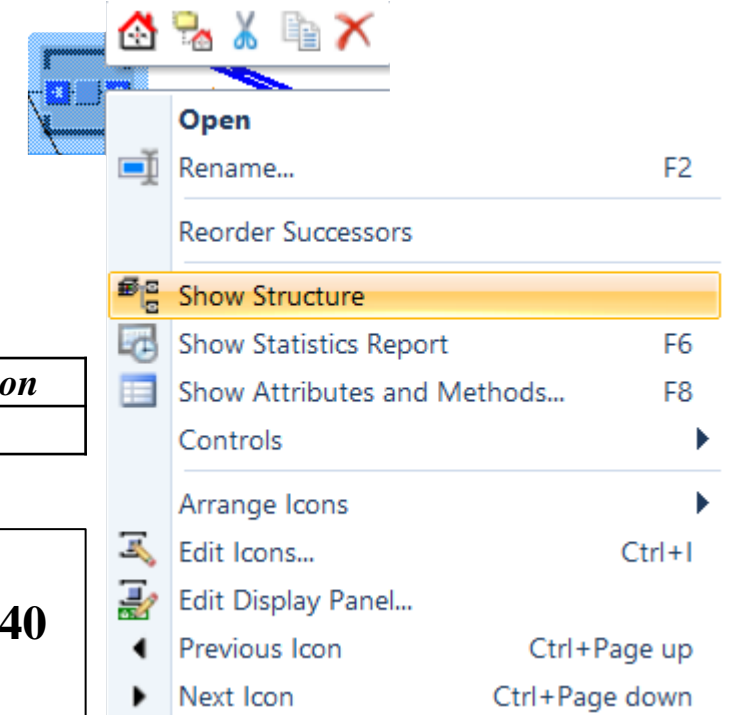
Attributes	Times	Failures	Controls	Exit Strategy	
Statistics	Energy	User-defined Attributes			
Resource type:	Storage	<input type="checkbox"/>			
<input checked="" type="checkbox"/> Resource status:	Production				
	Transport				
	Storage				
Working:	0.00%	Rel. occupation:	0.00%	Contents:	0
Setting-up:	0.00%	Rel. empty:	0.00%	Minimum contents:	0
Waiting:	0.00%	Rel. full:	0.00%	Maximum contents:	0
Blocked:	0.00%			Entries:	0
P. up/down:	0.00%			Exits:	0
Failed:	0.00%				
Stopped:	0.00%				
Paused:	0.00%				
Unplanned:	0.00%				

OK Cancel Apply



Empilhadeira_WIP

Empilhadeira



Waiting Time

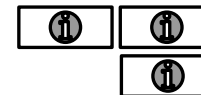
<i>Object</i>	<i>Portion</i>	<i>Count</i>	<i>Sum</i>	<i>Mean Value</i>	<i>Standard Deviation</i>
Empilhadeira_WIP	100.00%	34219	49:23:59:40.3446	2:06.2451	10.0415



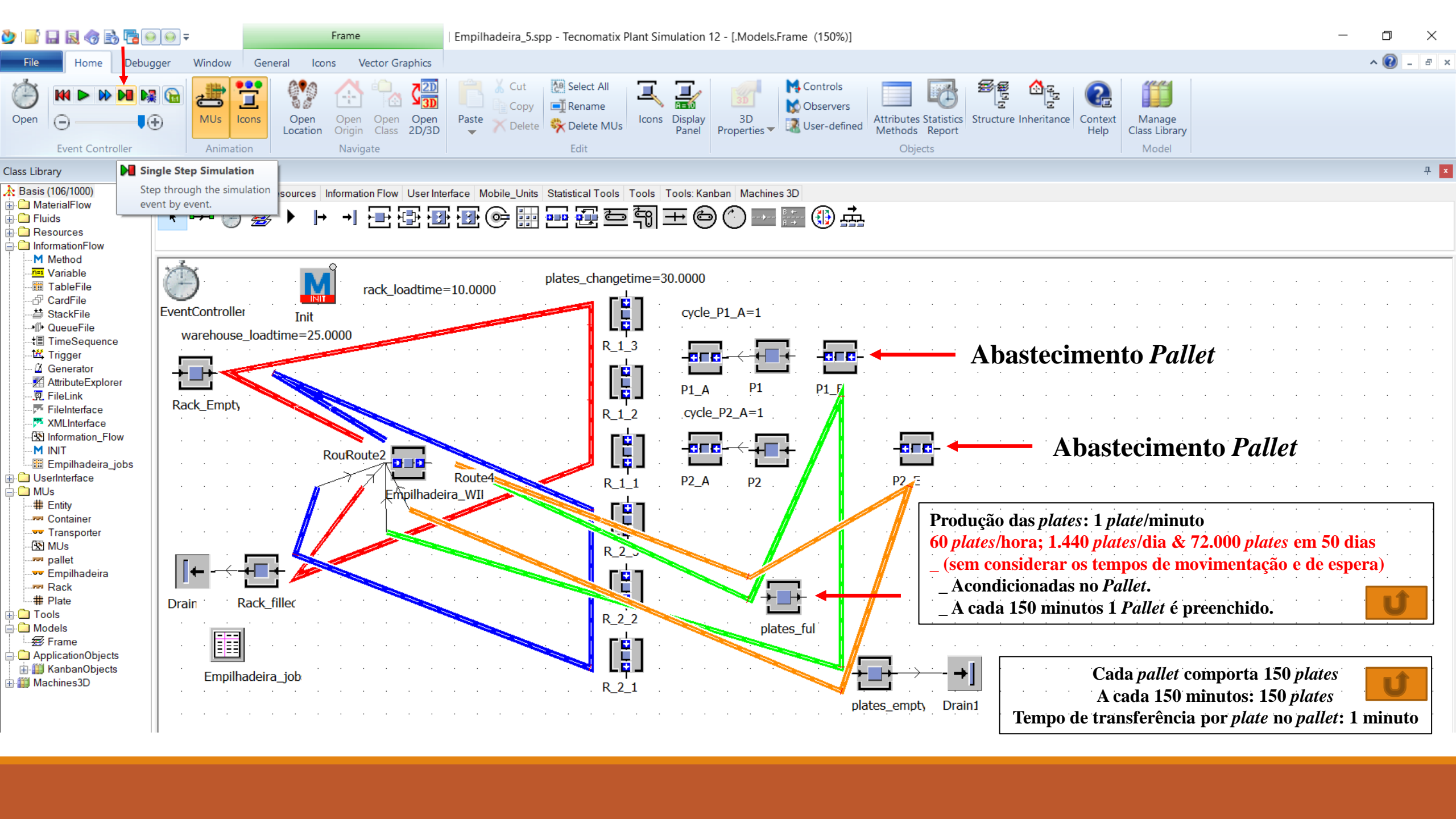
Rack – 30.192 \Rightarrow 30.192 * 20 = 603.840 plates

Pallet – 4.024 \Rightarrow 4.024 * 150 = 603.600 plates \Rightarrow Count = 603.840 – 603.600 = 240

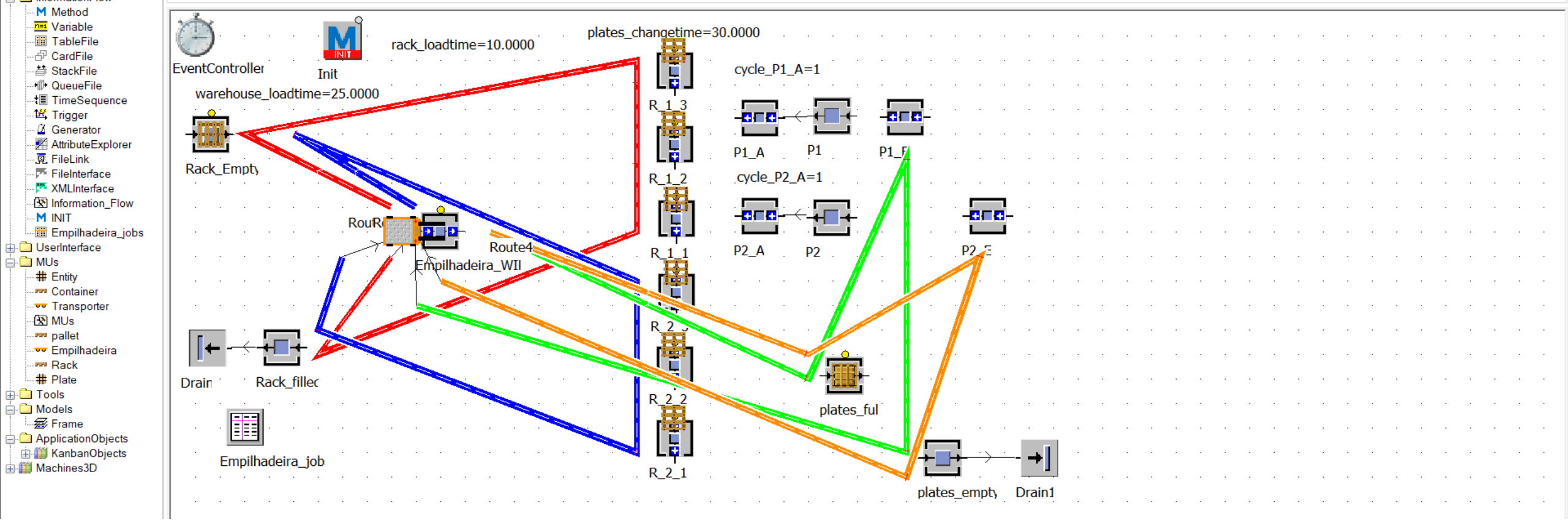
Total – 34.216 itens (30.192 Racks & 4.024 Pallets)



Descrição



Material Flow Fluids Resources Information Flow User Interface Mobile_Units Statistical Tools Tools Tools: Kanban Machines 3D



Empilhadeira_5.spp - Tecnomatix Plant Simulation 12 - [Models.Frame (150%)]

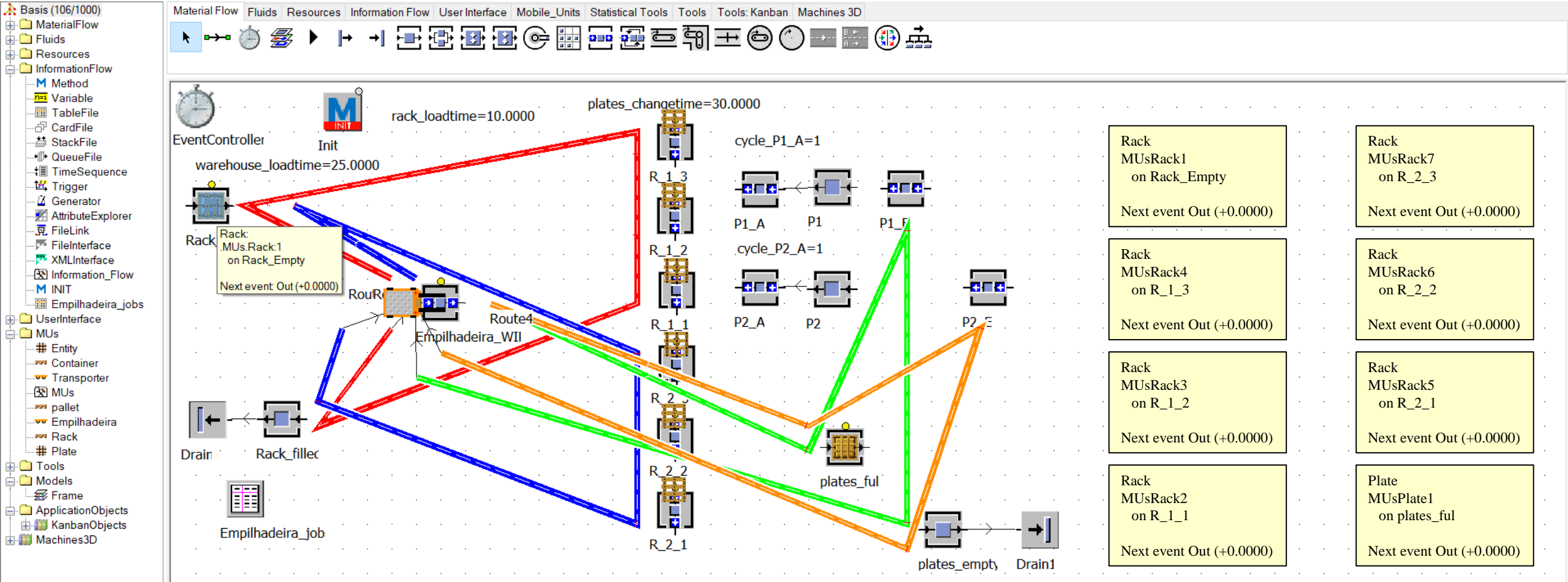
File Home Debugger Window General Icons Vector Graphics

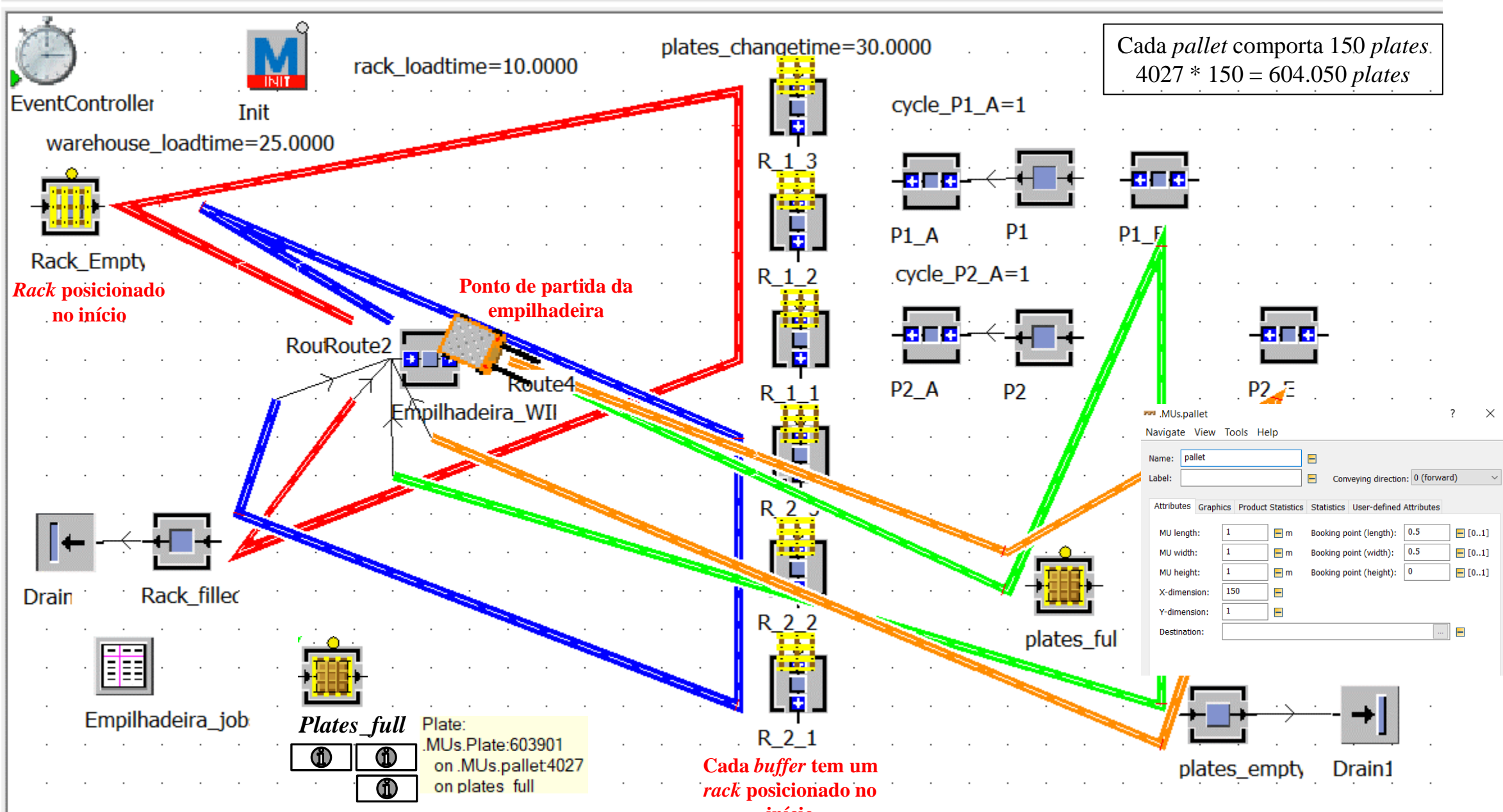
Open Event Controller Animation Navigate Edit Objects Model

MUs Icons Open Location Open Origin Open Class Open 2D/3D Paste Copy Delete Select All Rename Delete MUs Icons Display Panel 3D Properties Controls Observers User-defined Attributes Statistics Methods Report Structure Inheritance Context Help Manage Class Library

Class Library Toolbox

Material Flow Fluids Resources Information Flow User Interface Mobile_Units Statistical Tools Tools Tools: Kanban Machines 3D

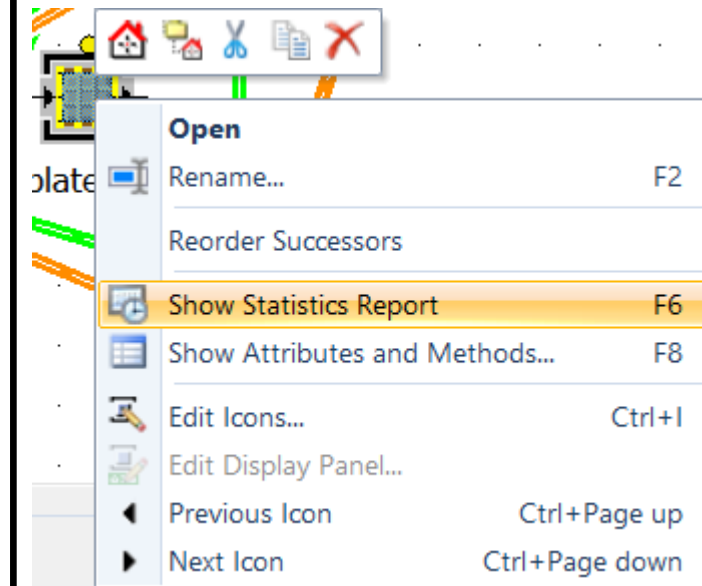
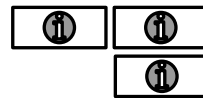




Statistics Report (plate_full)

Product-Oriented Statistics of all Existing and Deleted MUs (by Classes)

<i>Class</i>	<i>Count</i>	<i>Deleted</i>	<i>Mean Life Time</i>
<i>Plate</i>	210	603840	41:24.8238



Cada *pallet* comporta 150 *plates*
 $4027 * 150 = 604.050$ *plates*
 $604.050 - 603.840 = 210$ *plates*



Statistics Report (Rack_filled)

Rack $\Rightarrow 30.192 * 20 = 603.840$
Pallet $\Rightarrow 4.024 * 150 = 603.600$
Total de plates = 1.207.440

Cumulated Statistics of the Parts which the Drain Deleted

Object	Name	Mean Life Time	Throughput	TPH	Production	Transport	Storage	Value added	Portion
Drain	Rack	18:05.3374	30192	25	13.18%	8.65%	78.17%	0.00%	
Drain1	pallet	55:00.0839	4024	3	32.50%	2.47%	65.03%	0.00%	

The screenshot shows a context menu for an object named 'Rack'. The menu items are: Open, Rename... (F2), Reorder Successors, Show Structure, **Show Statistics Report (F6)**, Show Attributes and Methods... (F8), Arrange Icons, Edit Icons... (Ctrl+I), Edit Display Panel..., Previous Icon (Ctrl+Page up), and Next Icon (Ctrl+Page down). An arrow points from the 'Show Statistics Report' option to the table above.

Cada pallet comporta 150 plates
 $4027 * 150 = 604.050 \text{ plates}$
 $604.050 - 603.840 = 210 \text{ plates}$
 $603.840 / 150 = 4.025,6 \approx 4.025 \text{ pallets}$

Cada rack comporta 20 pallets
 $603.840 / 20 = 30.192 \text{ racks}$

50 dias x 24 horas = 1.200 horas

Rack $\Rightarrow 30.192 / 1.200 \approx 25.16 \approx 25$ unidades por hora

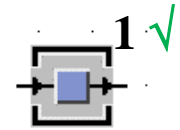
Pallet $\Rightarrow 4.024 / 1.200 \approx 3.3533 \approx 3$ unidades por hora

Product-Oriented Statistics of all Existing and Deleted MUs (by Classes)

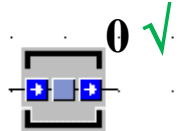
Class	Count	Deleted	Mean Life Time
Plate	210	603840	41:24.8238



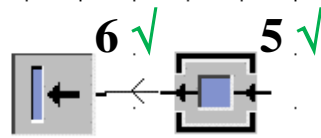
Operação



Rack_Empty



Empilhadeira_WIP

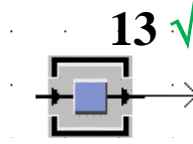
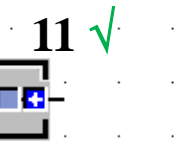
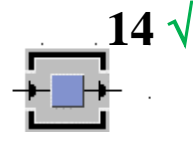
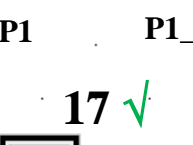
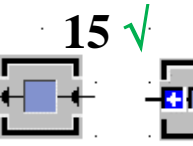
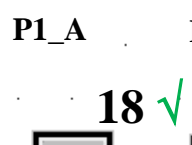
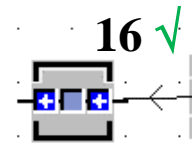
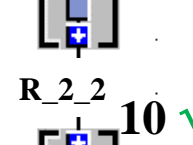
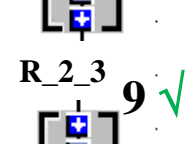
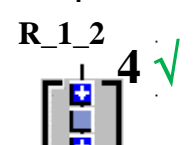
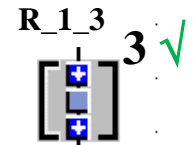
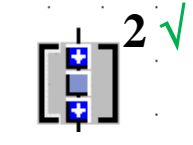


Drain

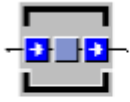
Rack_Filled



Empilhadeira_job



Plates_Empty *Drain1*



0

Empilhadeira_WIP

```

is
do
    waituntil Empilhadeira_jobs.yDim > 0 prio 1;
    --move to the specified route
    @.move(str_to_obj(Empilhadeira_jobs[1,1]));
    --delete job
    Empilhadeira_jobs.cutRow(1);
end;

```

Objeto: *Buffer*
 _ função: coordenar a empilhadeira

Capacity ⇒ **1**



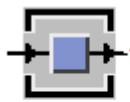
7

Empilhadeira_jobs

	string 1	string 2
string	Route	
1		
2		
3		

Route4		
	string 1	string 2
string	Route	
1	Route4	
2	Route2	
3	Route1	

Objeto: *Table*
 _ função: controle das *Routes*



1

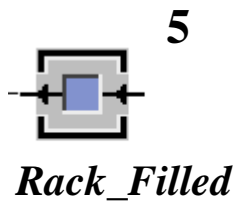
Rack_Empty

```

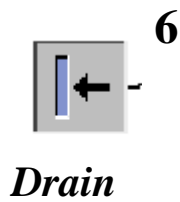
is
do
    .MUs.Rack.create(?);
end;

```

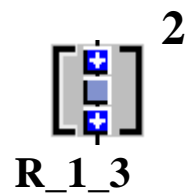
Objeto: *SingleProc*
 _ função: criar o *Rack*



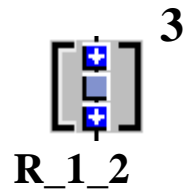
Objeto: *SingleProc*
_ função: *Rack* carregado



Objeto: *Drain*
_ função: expedição *Rack* carregado



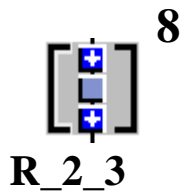
Objeto: *Buffer*
_ função: capacidade = 1 (*Route* 1)



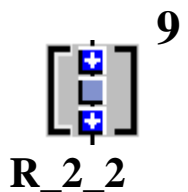
Objeto: *Buffer*
_ função: capacidade = 1 (*Route* 1)



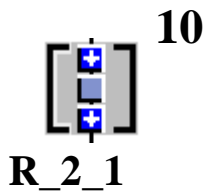
Objeto: *Buffer*
_ função: capacidade = 1 (*Route 1*)



Objeto: *Buffer*
_ função: capacidade = 1 (*Route 2*)



Objeto: *Buffer*
_ função: capacidade = 1 (*Route 2*)



Objeto: *Buffer*
_ função: capacidade = 1 (*Route 2*)

OnExit (**P1_A**) (**Parte I**)

is

```
    rackplace:object;
```

do

```
    -- select rack using a cycle
```

```
    if cycle_P1_A=1 then
```

```
        rackplace:=R_1_1;
```

```
    elseif cycle_P1_A=2 then
```

```
        rackplace:=R_1_2;
```

```
    else
```

```
        rackplace:=R_1_3;
```

```
end;
```


OnExit (**P1_A**) (**Parte II**)

```
waituntil rackplace.occupied prio 1;
--wait for a change, if the rack is still full
if rackplace.cont.full then
    waituntil rackplace.empty prio 1;
    waituntil rackplace.occupied prio 1;
end;

--move
@.move(rackplace.cont);

--if full, enter job into forklift_jobs and increment cycle
if rackplace.cont.full then
```

OnExit (**P1_A**) (**Parte III**)

```
        Empilhadeira_jobs.writeRow(1,Empilhadeira_jobs.yDim+1,
        "Route1");

    cycle_P1_A:=cycle_P1_A+1;

    if      cycle_P1_A=4 then
        cycle_P1_A:=1;

    end;

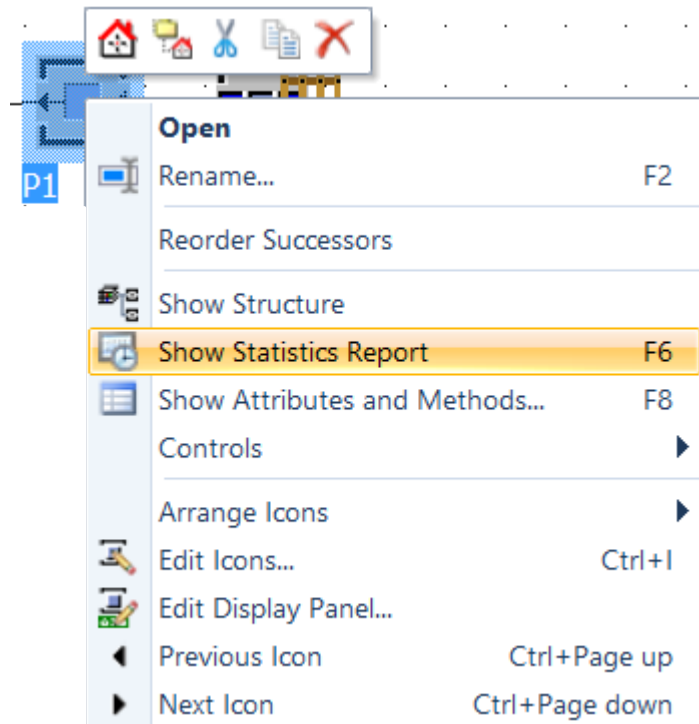
end;

end;
```

Statistics Report (P1)

Material Flow Properties

Object	Number of Entries	Number of Exits	Minimum Contents	Maximum Contents	Relative Empty	Relative Full	Relative Occupation without Interruptions	Relative Occupation with Interruptions
P1	301950	301950	0	1	8.76%	-	91.24%	91.24



Cada pallet comporta 150 plates
 $301.950 / 150 = 2.013 \text{ pallets}$

Working Time

Object	Portion	Count	Sum	Mean Value	Standard Deviation
P1	83.88%	301950	41:22:30:00.0000	12.0000	0.0000

12 segundos

2.013 pallets recurso P1
 2.013 pallets recurso P2
 Total: 4.026 pallets
 Total: $4.026 * 150 = 603.900 \text{ plates}$



OnExit (**P2_A**) (**Parte I**)

is

```
    rackplace:object;
```

do

```
    -- select rack using a cycle
```

```
    if cycle_P2_A=1 then
```

```
        rackplace:=R_2_1;
```

```
    elseif cycle_P2_A=2 then
```

```
        rackplace:=R_2_2;
```

```
    else
```

```
        rackplace:=R_2_3;
```

```
end;
```

OnExit (**P2_A**) (**Parte II**)

```
waituntil rackplace.occupied prio 1;
--wait for a change, if the rack is still full
if rackplace.cont.full then
    waituntil rackplace.empty prio 1;
    waituntil rackplace.occupied prio 1;
end;

--move
@.move(rackplace.cont);

--if full, enter job into forklift_jobs and increment cycle
if rackplace.cont.full then
```

OnExit (**P2_A**) (**Parte III**)

```
        Empilhadeira_jobs.writeRow(1,Empilhadeira_jobs.yDim+1,
        "Route2");

    cycle_P2_A:=cycle_P2_A+1;

    if      cycle_P2_A=4 then
        cycle_P2_A:=1;

    end;

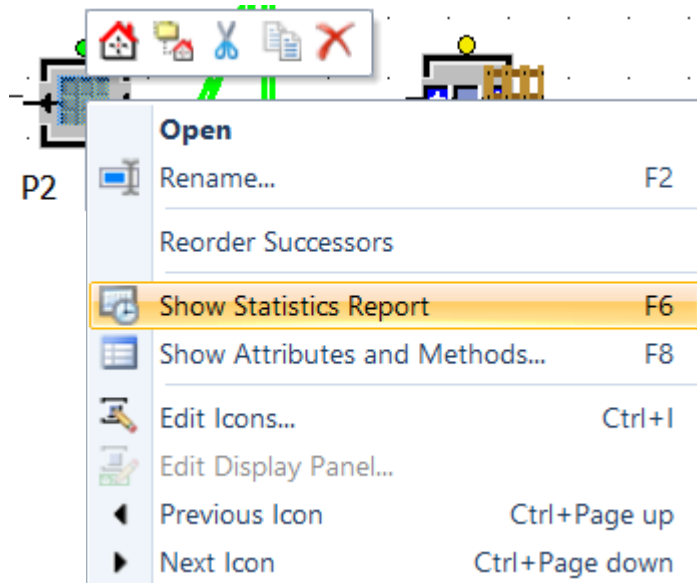
end;

end;
```

Statistics Report (P2)

Material Flow Properties

Object	Number of Entries	Number of Exits	Minimum Contents	Maximum Contents	Relative Empty	Relative Full	Relative Occupation without Interruptions	Relative Occupation with Interruptions
P1	301950	301950	0	1	8.76%	-	91.24%	91.24



Cada pallet comporta 150 plates
 $301.950 / 150 = 2.013$ pallets

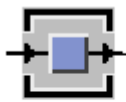
Working Time

Object	Portion	Count	Sum	Mean Value	Standard Deviation
P1	83.88%	301950	41:22:30:00.0000	12.0000	0.0000

12 segundos

2.013 pallets recurso P1
 2.013 pallets recurso P2
 Total: 4.026 pallets
 Total: $4.026 * 150 = 603.900$ plates



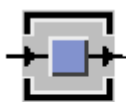


14
Plates_Full

```
is
do
    pallet:object;
    pallet:=.MUs.Pallet.create(?);
    while not pallet.full loop
        .MUs.Plate.create(pallet);
    end;
end;
```


Objeto: *SingleProc*
_ função: processo

Processing Time ⇒ **1:00 (minuto)**
_ **por plate**



13
Plates_Empty

Objeto: *SingleProc*
_ função: descarregar *Plates*



19
Drain1

Objeto: *Drain*
_ função: expedição *Plates*



Exemplo: produção (*hack – pallet – plate*)



Shift_Calendar

.Models.Frame.Shift_Calendar ? X

File Navigate View Tools Help

Name: Shift_Calendar Active

Label:

Shift Times Calendar Resources User-defined Attributes

	Shift	From	To	M	Tu	W	Th	Fr	Sa	So	Pauses
1	Shif	7:00	17:00	<input checked="" type="checkbox"/>	<input checked="" type="checkbox"/>	<input checked="" type="checkbox"/>	<input checked="" type="checkbox"/>	<input checked="" type="checkbox"/>	<input type="checkbox"/>	<input type="checkbox"/>	9:00-9:15; 12:00-1...
2	Shif	7:00	17:00	<input type="checkbox"/>	<input type="checkbox"/>	<input type="checkbox"/>	<input type="checkbox"/>	<input type="checkbox"/>	<input checked="" type="checkbox"/>	<input checked="" type="checkbox"/>	7:00-17:00

09:00 – 09:15
12:00 – 12:30
15:00 – 15:15

Calendário

Dia	Data	Dia da semana	Disponibilidade
01	16/10/2018	terça	8
02	17/10/2018	quarta	8
03	18/10/2018	quinta	8
04	19/10/2018	sexta	8
05	20/10/2018	sábado	0
06	21/10/2018	domingo	0
07	22/10/2018	segunda	8
08	23/10/2018	terça	8
09	24/10/2018	quarta	8
10	25/10/2018	quinta	8
11	26/10/2018	sexta	8
12	27/10/2018	sábado	0
13	28/10/2018	domingo	0
14	29/10/2018	segunda	8
15	30/10/2018	terça	8
16	31/10/2018	quarta	8

...Frame.EventContr... ? X

Navigate View Tools Help

Time 50:00:00:00.0000

Controls Settings

Date: 2018/10/16 07:00:00

End: 50:00:00:00

Statistics: 0

- Delete MUs on reset
- Step over animation events
- Show summary report

Calendário

Dia	Data	Dia da semana	Disponibilidade
17	01/11/2018	quinta	8
18	02/11/2018	sexta	8
19	03/11/2018	sábado	0
20	04/11/2018	domingo	0
21	05/11/2018	segunda	8
22	06/11/2018	terça	8
23	07/11/2018	quarta	8
24	08/11/2018	quinta	8
25	09/11/2018	sexta	8
26	10/11/2018	sábado	0
27	11/11/2018	domingo	0
28	12/11/2018	segunda	8
29	13/11/2018	terça	8
30	14/11/2018	quarta	8
31	15/11/2018	quinta	8
32	16/11/2018	sexta	8

...Frame.EventContr... ? X

Navigate View Tools Help

Time 50:00:00:00.0000

Controls Settings

Date: 2018/10/16 07:00:00

End: 50:00:00:00

Statistics: 0

- Delete MUs on reset
- Step over animation events
- Show summary report

Calendário

Dia	Data	Dia da semana	Disponibilidade
33	17/11/2018	sábado	0
34	18/11/2018	domingo	0
35	19/11/2018	segunda	8
36	20/11/2018	terça	8
37	21/11/2018	quarta	8
38	22/11/2018	quinta	8
39	23/11/2018	sexta	8
40	24/11/2018	sábado	0
41	25/11/2018	domingo	0
42	26/11/2018	segunda	8
43	27/11/2018	terça	8
44	28/11/2018	quarta	8
45	29/11/2018	quinta	8
46	30/11/2018	sexta	8
47	01/12/2018	sábado	0
48	02/12/2018	domingo	0

🕒 ...Frame.EventContr... ? ✕

Navigate View Tools Help

Time 50:00:00:00.0000

Controls Settings

Date: 2018/10/16 07:00:00

End: 50:00:00:00

Statistics: 0

- Delete MUs on reset
- Step over animation events
- Show summary report

Calendário

Dia	Data	Dia da semana	Disponibilidade
49	03/12/2018	segunda	8
50	04/12/2018	terça	8
Σ			288 horas

...Frame.EventContr... ? X

Navigate View Tools Help

Time 50:00:00:00.0000

Controls Settings

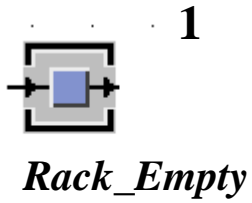
Date: 2018/10/16 07:00:00

End: 50:00:00:00

Statistics: 0

- Delete MUs on reset
- Step over animation events
- Show summary report

Calendário



.Models.Frame.Rack_Empty ? X

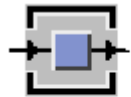
Navigate View Tools Help

Name: Rack_Empty [dropdown] Failed Entrance locked

Label: [text] Unplanned [dropdown] Exit locked

Importer	Failure Importer	Energy	User-defined Attributes	
Times	Set-Up	Failures	Exit Strategy	Statistics
Entrance:	[text] [dropdown] <input type="checkbox"/>		<input type="checkbox"/> Before actions <input type="checkbox"/>	
Exit:	self.OnExit [dropdown] <input type="checkbox"/>		<input type="checkbox"/> Front <input checked="" type="checkbox"/> Rear <input type="checkbox"/>	
			<input type="checkbox"/> Exit control once <input type="checkbox"/>	
Set-up:	[text] [dropdown] <input type="checkbox"/>			
Pull:	[text] [dropdown] <input type="checkbox"/>			
Shift calendar:	Shift_Calendar [dropdown] <input type="checkbox"/>			

Calendário



14

Plates_Full

.Models.Frame.plates_full ? X

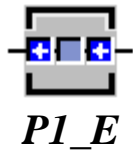
Navigate View Tools Help

Name: plates_full [dropdown] Failed Entrance locked

Label: [input] Unplanned [dropdown] Exit locked

Importer	Failure Importer	Energy	User-defined Attributes	
Times	Set-Up	Failures	Exit Strategy	Statistics
Entrance:	[input] [dropdown] <input type="checkbox"/>	[input] [dropdown] <input type="checkbox"/>	<input type="checkbox"/> Before actions <input type="checkbox"/>	<input type="checkbox"/>
Exit:	self.OnExit [dropdown] <input type="checkbox"/>	[input] [dropdown] <input type="checkbox"/>	<input type="checkbox"/> Front <input checked="" type="checkbox"/> Rear <input type="checkbox"/>	[dropdown] <input type="checkbox"/>
			<input type="checkbox"/> Exit control once <input type="checkbox"/>	[dropdown] <input type="checkbox"/>
Set-up:	[input] [dropdown] <input type="checkbox"/>			
Pull:	[input] [dropdown] <input type="checkbox"/>			
Shift calendar:	Shift_Calendar [dropdown] <input type="checkbox"/>			

Calendário



11

P1_E

.Models.Frame.P1_E ? X

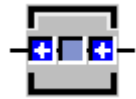
Navigate View Tools Help

Name: P1_E Failed Entrance locked

Label: Unplanned Exit locked

Statistics		Energy		User-defined Attributes	
Attributes	Times	Failures	Controls	Exit Strategy	
Entrance:	<input type="text"/>	<input type="checkbox"/>	<input type="checkbox"/> Before actions <input type="checkbox"/>		
Exit:	self.OnExit	<input type="checkbox"/>	<input checked="" type="checkbox"/> Front <input type="checkbox"/> Rear <input type="checkbox"/>		
			<input type="checkbox"/> Exit control once <input type="checkbox"/>		
Pull:	<input type="text"/>	<input type="checkbox"/>			
Shift calendar:	Shift_Calendar	<input type="checkbox"/>			

Calendário



12

P2_E

.Models.Frame.P2_E ? X

Navigate View Tools Help

Name: P2_E Failed Entrance locked

Label: Unplanned Exit locked

Statistics		Energy		User-defined Attributes	
Attributes	Times	Failures	Controls	Exit Strategy	
Entrance:	<input type="text"/>	<input type="checkbox"/>	<input type="checkbox"/> Before actions <input type="checkbox"/>		
Exit:	self.OnExit	<input type="checkbox"/>	<input checked="" type="checkbox"/> Front <input type="checkbox"/> Rear <input type="checkbox"/>		
			<input type="checkbox"/> Exit control once <input type="checkbox"/>		
Pull:	<input type="text"/>	<input type="checkbox"/>			
Shift calendar:	Shift_Calendar	<input type="checkbox"/>			

Produção



Cumulated Statistics of the Parts which the Drain Deleted

<i>Cumulated Statistics of the Parts which the Drain Deleted</i>									
<i>Object</i>	<i>Name</i>	<i>Mean Life Time</i>	<i>Throughput</i>	<i>TPH</i>	<i>Production</i>	<i>Transport</i>	<i>Storage</i>	<i>Value added</i>	<i>Portion</i>
Drain	<i>Rack</i>	17:38.1939	134	0	13.06%	8.61%	78.33%	0.00%	
Drain1	<i>pallet</i>	48:35.3511	18	0	32.61%	2.79%	64.60%	0.00%	

_ Disponibilidade = 288 horas

Produção Pallet $\Rightarrow 32,61\% * 288 \text{ horas} = 93,9168 \text{ horas}$

Produção Pallet $\Rightarrow 93,9168 * 60 = 5.635,008 \text{ minutos}$

_ Produção

<i>Item</i>	<i>Produção</i>	<i>Total de Plates por item</i>	<i>Produção Plates</i>
<i>Rack</i>	134	20	2.680
<i>Pallet</i>	18	150	2.700
	Σ		5.380

Produção



Tempo de processamento por unidade de *plate*:

_ tempo de processamento por unidade de *plate* = $\frac{5.635,008 \text{ minutos}}{5.380 \text{ plates}} = 1,047399 \text{ minutos}$

_ tempo de processamento de uma *plate* \approx 1 minuto (00:00:01:00,00)

_ produção total de *plates* para atender tanto a produção de *pallets* do *Drain1* quanto a produção dos *Racks* do *Drain*



14

Plates_Full

Produção



Cumulated Statistics of the Parts which the Drain Deleted

<i>Cumulated Statistics of the Parts which the Drain Deleted</i>									
<i>Object</i>	<i>Name</i>	<i>Mean Life Time</i>	<i>Throughput</i>	<i>TPH</i>	<i>Production</i>	<i>Transport</i>	<i>Storage</i>	<i>Value added</i>	<i>Portion</i>
Drain	<i>Rack</i>	17:38.1939	134	0	13.06%	8.61%	78.33%	0.00%	
Drain1	<i>pallet</i>	48:35.3511	18	0	32.61%	2.79%	64.60%	0.00%	

_ Disponibilidade = 288 horas

Produção Rack \Rightarrow 13,06% = 37,6128 horas

Produção Rack \Rightarrow 37,6128 * 60 = 2.256,768 minutos

_ Produção

<i>Item</i>	<i>Produção</i>	<i>Total de Plates por item</i>	<i>Produção Plates</i>
<i>Rack</i>	134	20	2.680
<i>Pallet</i>	18	150	2.700
	Σ		5.380

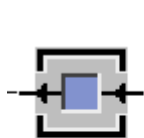
Produção



Tempo de processamento por unidade de *plate*:

$$\text{_ tempo de processamento por unidade de plate} = \frac{2.256,768 \text{ minutos}}{2.680 \text{ plates}} = 0,8421 \text{ minutos}$$

$$\text{_ tempo de processamento de uma plate} = 0,8421 \text{ minutos} * 60 = 50,525 \text{ segundos por Rack}$$



5

Rack_Filled

Material Flow Properties

<i>Object</i>	<i>Number of Entries</i>	<i>Number of Exits</i>
<i>Rack_filled</i>	134	134

Produção



Material Flow Properties

<i>Object</i>	<i>Number of Entries</i>	<i>Number of Exits</i>	<i>Relative Empty</i>
P1	1350	1350	99.60%
P2	1350	1350	99.60%

Working Time

<i>Object</i>	<i>Portion</i>	<i>Count</i>	<i>Sum</i>	<i>Mean Value</i>	<i>Standard Deviation</i>
P1	0.38%	1350	4:30:00.0000	12.0000	0.0000
P2	0.38%	1350	4:30:00.0000	12.0000	0.0000

Produção



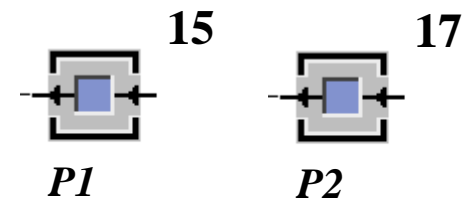
Tempo de processamento por unidade de *plate* nos recursos P1 e P2:

_ *tempo de processamento por unidade de plate* = 12 segundos

_ **P1** \Rightarrow 12 segundos * 1350 = 16.200 segundos = **270 minutos**

_ **P2** \Rightarrow 12 segundos * 1350 = 16.200 segundos = **270 minutos**

No.	Resource/Order	6 07														08																																									
		57	59	01	03	05	07	09	11	13	15	17	19	21	23	25	27	29	31	33	35	37	39	41	43	45	47	49	51	53	55	57	59	01	03	05	07	09	11	13	15	17	19	21	23	25	27	29	31	33	35	37	39	41	43	45	47
1	P1	[Gantt chart for P1: bars from 01 to 31, 33 to 59, 01 to 15, 17 to 31, 33 to 47, 49 to 59]														[Gantt chart for P1: bar from 17 to 21]																																									
2	P2	[Gantt chart for P2: bars from 01 to 15, 17 to 31, 33 to 47, 49 to 59]														[Gantt chart for P2: bar from 17 to 21]																																									

















Movimentação

Definição do espaço

COORDENADAS CARTESIANAS – *PLANT SIMULATION*



Sumário (movimentação)

-  **Configuração da Grade**
-  **Configuração Coordenadas**
-  **Configuração dimensionamento da área**
-  **Configuração da Escala**
-  **Empilhadeira (*Forklift*) – Rotas (Exemplo: *Track*)**
-  **Empilhadeira (*Forklift*) – *Routes***  ***Routes 1***  ***Routes 2***  ***Routes 3***  ***Routes 4***
-  ***Icons***
-  ***Forklift* – Ponto de Referência**
-  ***Forklift* – Posição *pallet* garfo empilhadeira (Ponto de ANIMAÇÃO)**
-  **Método INIT**

CONFIGURAÇÃO DA GRADE

Frame NoName.spp - Tecnomatix Plant Simulation 12 - [.Models.Frame]

File Home Debugger Window General Icons Vector Graphics

Print Find Object Unconnected No Length Transfer Zoom In Original Size Zoom Out Scaling Factor Representation Shift Calendar Ribbon Tab Context Menu Background Replacement Mode Lock Structure Names Connections Comments Grid More Inherit Options

Actions Show Zoom Settings View Options

Class Library

- Basis (83/1000)
 - MaterialFlow
 - Fluids
 - Resources
 - InformationFlow
 - UserInterface
 - MUs
 - Tools
 - Models
 - Frame
 - ApplicationObjects
 - KanbanObjects
 - Machines3D

Toolbox

Material Flow Fluids Resources Information Flow User Interface Mobile Units Tools Statistical Tools Tools: Kanban Machines 3D

EventController

.Models.Frame

0.0000 OVR CAP NUM SCRL

13:35 16/10/2018

Frame

NoName.spp - Tecnomatix Plant Simulation 12 - [.Models.Frame]

File Home Debugger Window General Icons Vector Graphics

Print Find Object Unconnected No Length Transfer Zoom In Original Size Zoom Out Scaling Factor Representation Shift Calendar Ribbon Tab Context Menu Background Replacement Mode Lock Structure Names Connections Comments Grid More Inherit Options

Class Library

- Basis (83/1000)
 - MaterialFlow
 - Fluids
 - Resources
 - InformationFlow
 - UserInterface
 - MUs
 - Tools
 - Models
 - Frame
 - ApplicationObjects
 - KanbanObjects
 - Machines3D

Toolbox

Material Flow Fluids Resources Information Flow User Interface Mobile Units Tools Statistical Tools Tools: Kanban Machines 3D

EventController

.Models.Frame

0.0000 OVR CAP NUM SCRL

Windows taskbar with search bar, icons for Edge, File Explorer, Store, Task Manager, Chrome, Firefox, Word, Mail, Teams, and PowerPoint. System tray shows 'Área de Trabalho', network, volume, and date/time: 13:35 16/10/2018.

CONFIGURAÇÃO COORDENADAS

Frame NoName.spp - Tecnomatix Plant Simulation 12 - [Models.Frame]

File Home Debugger Window General Icons Vector Graphics

Print Find Object Unconnected Objects No Length Transfer Zoom In Original Size Zoom Out Scaling Factor Representation Shift Calendar Ribbon Tab Context Menu Background Replacement Mode Lock Structure Names Connections Comments Grid More Inherit Options

Class Library

- Basis (83/1000)
- MaterialFlow
- Fluids
- Resources
- InformationFlow
- UserInterface
- Mobile Units
- Tools
- Statistical Tools
- Tools: Kanban
- Machines 3D
- Models
 - Frame
- ApplicationObjects
- KanbanObjects
- Machines3D

Material Flow Fluids Resources Information Flow User Interface Mobile Units Tools Statistical Tools Tools: Kanban Machines 3D

EventController

.Models.Frame

CONFIGURAÇÃO DIMENSIONAMENTO DA ÁREA

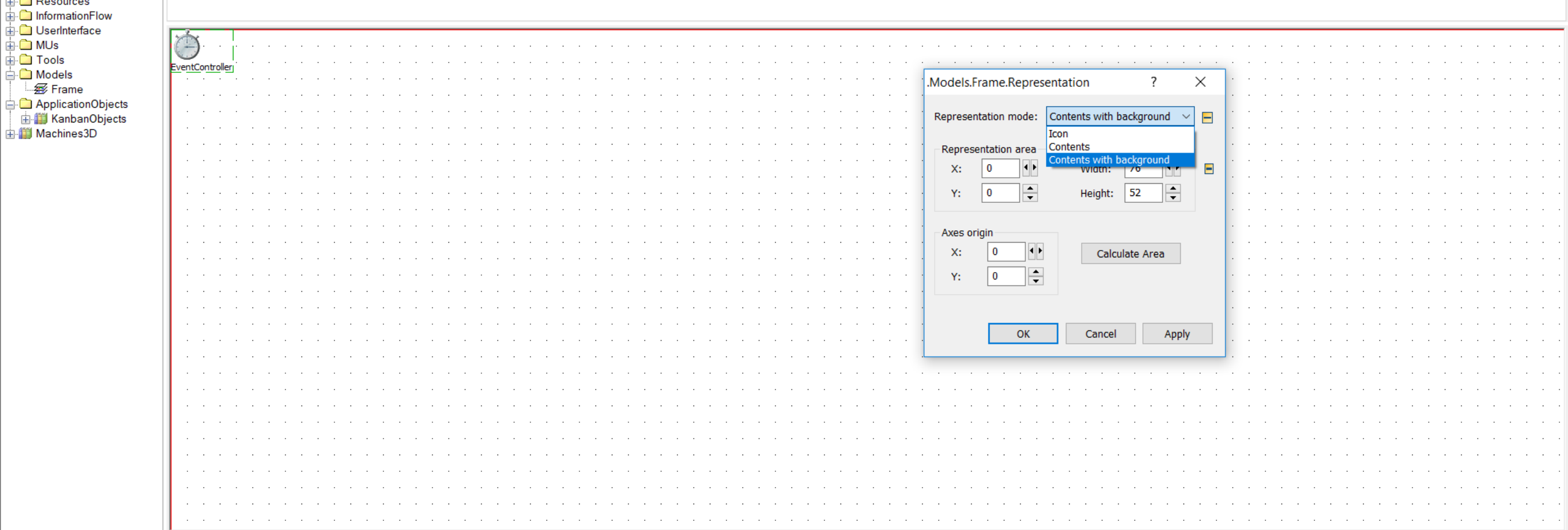
File Home Debugger Window General Icons Vector Graphics

Print Find Object Unconnected Objects No Length Transfer Zoom In Original Size Zoom Out Scaling Factor Representation Shift Calendar Ribbon Tab Context Menu Background Replacement Mode Lock Structure Names Connections Comments Grid More Inherit Options

Actions Show Zoom Settings View Options

Class Library Toolbox

Material Flow Fluids Resources Information Flow User Interface Mobile Units Tools Statistical Tools Tools: Kanban Machines 3D



.Models.Frame.Representation ? X

Representation mode: Contents with background (dropdown menu open showing Icon, Contents, Contents with background)

Representation area
X: 0 Width: 76
Y: 0 Height: 52

Axes origin
X: 0
Y: 0

Calculate Area

OK Cancel Apply

File Home Debugger Window General Icons Vector Graphics

Print Find Object Unconnected Objects No Length Transfer Zoom In Original Size Zoom Out Scaling Factor Representation Shift Calendar Ribbon Tab Context Menu Background Replacement Mode Lock Structure Names Connections Comments Grid More Inherit Options

Actions Show Zoom Settings View Options

Class Library Toolbox

Material Flow Fluids Resources Information Flow User Interface Mobile Units Tools Statistical Tools Tools: Kanban Machines 3D

Class Library: Basis (83/1000), MaterialFlow, Fluids, Resources, InformationFlow, UserInterface, MUs, Tools, Models, Frame, ApplicationObjects, KanbanObjects, Machines3D

Toolbox: Material Flow, Fluids, Resources, Information Flow, User Interface, Mobile Units, Tools, Statistical Tools, Tools: Kanban, Machines 3D

EventController

.Models.Frame.Representation ? X

Representation mode: Contents with background

Representation area
X: 0 Width: 76
Y: 0 Height: 52

Axes origin
X: 0
Y: 0

Calculate Area

OK Cancel Apply

Frame NoName.spp - Tecnomatix Plant Simulation 12 - [.Models.Frame]

File Home Debugger Window General Icons Vector Graphics

Print Find Object Unconnected Objects No Length Transfer Zoom In Original Size Zoom Out Scaling Factor Representation Shift Calendar Ribbon Tab Context Menu Background Replacement Mode Lock Structure Names Connections Comments Grid More Inherit Options

Class Library

- Basis (83/1000)
- MaterialFlow
- Fluids
- Resources
- InformationFlow
- UserInterface
- MUs
- Tools
- Models
 - Frame
- ApplicationObjects
- KanbanObjects
- Machines3D

Material Flow Fluids Resources Information Flow User Interface Mobile Units Tools Statistical Tools Tools: Kanban Machines 3D

EventController

.Models.Frame.Representation ? X

Representation mode: Icon

Representation area

X: 0 Width: 0

Y: 0 Height: 0

Axes origin

X: 300 Y: 300

Calculate Area

OK Cancel Apply

0.0000 OVR CAP NUM SCRL

Área de Trabalho 13:40 16/10/2018

File Home Debugger Window General Icons Vector Graphics

Print Find Object Unconnected Objects No Length Transfer Zoom In Original Size Zoom Out Scaling Factor Representation Shift Calendar Ribbon Tab Context Menu Background Replacement Mode Lock Structure Names Connections Comments Grid More Inherit Options

Actions Show Zoom Settings View Options

Class Library Toolbox

Material Flow Fluids Resources Information Flow User Interface Mobile Units Tools Statistical Tools Tools: Kanban Machines 3D

Class Library: Basis (83/1000), MaterialFlow, Fluids, Resources, InformationFlow, UserInterface, MUs, Tools, Models, Frame, ApplicationObjects, KanbanObjects, Machines3D

Toolbox: Material Flow, Fluids, Resources, Information Flow, User Interface, Mobile Units, Tools, Statistical Tools, Tools: Kanban, Machines 3D

EventController

.Models.Frame.Representation ? X

Representation mode: Contents with background

Representation area

X: 0 Width: 300

Y: 0 Height: 300

Axes origin

X: 0 Y: 0

Calculate Area

OK Cancel Apply

File Home Debugger Window General Icons Vector Graphics

Print Find Object Unconnected Objects No Length Transfer Zoom In Original Size Zoom Out Scaling Factor Representation Shift Calendar Ribbon Tab Context Menu Background Replacement Mode Lock Structure Names Connections Comments Grid More Inherit Options

Actions Show Zoom Settings View Options

Class Library Toolbox

Material Flow Fluids Resources Information Flow User Interface Mobile Units Tools Statistical Tools Tools: Kanban Machines 3D

Class Library: Basis (83/1000), MaterialFlow, Fluids, Resources, InformationFlow, UserInterface, MUs, Tools, Models, Frame, ApplicationObjects, KanbanObjects, Machines3D

Toolbox: Material Flow, Fluids, Resources, Information Flow, User Interface, Mobile Units, Tools, Statistical Tools, Tools: Kanban, Machines 3D

EventController

.Models.Frame.Representation ? X

Representation mode: Contents with background

Representation area
X: 0 Width: 600
Y: 0 Height: 600

Axes origin
X: 0
Y: 0

Calculate Area

OK Cancel Apply

File Home Debugger Window General Icons Vector Graphics

Print Find Object Unconnected Objects No Length Transfer Zoom In Original Size Zoom Out Scaling Factor Representation Shift Calendar Ribbon Tab Context Menu Background Replacement Mode Lock Structure Names Connections Comments Grid More Inherit Options

Actions Show Zoom Settings View Options

Class Library Toolbox

Material Flow Fluids Resources Information Flow User Interface Mobile Units Tools Statistical Tools Tools: Kanban Machines 3D

Basis (83/1000)

- MaterialFlow
- Fluids
- Resources
- InformationFlow
- UserInterface
- MUs
- Tools
- Models
- Frame
- ApplicationObjects
- KanbanObjects
- Machines3D

EventController

File Home Debugger Window General Icons Vector Graphics

Print Find Object Unconnected Objects No Length Transfer Zoom In Original Size Zoom Out Scaling Factor Representation Shift Calendar Ribbon Tab Context Menu Background Replacement Mode Lock Structure Names Connections Comments Grid More Inherit Options

Actions Show Zoom Settings View Options

Class Library Toolbox

Material Flow Fluids Resources Information Flow User Interface Mobile Units Tools Statistical Tools Tools: Kanban Machines 3D

EventController

Scaling Factor

Enter the scaling factor to compute the length of polygon lines to be created in this Frame.

The factor you enter is the length of one pixel in length units. See 'File > Model Settings > Units > Length' and 'File > Model Settings > Modeling > Frame grid spacing'.

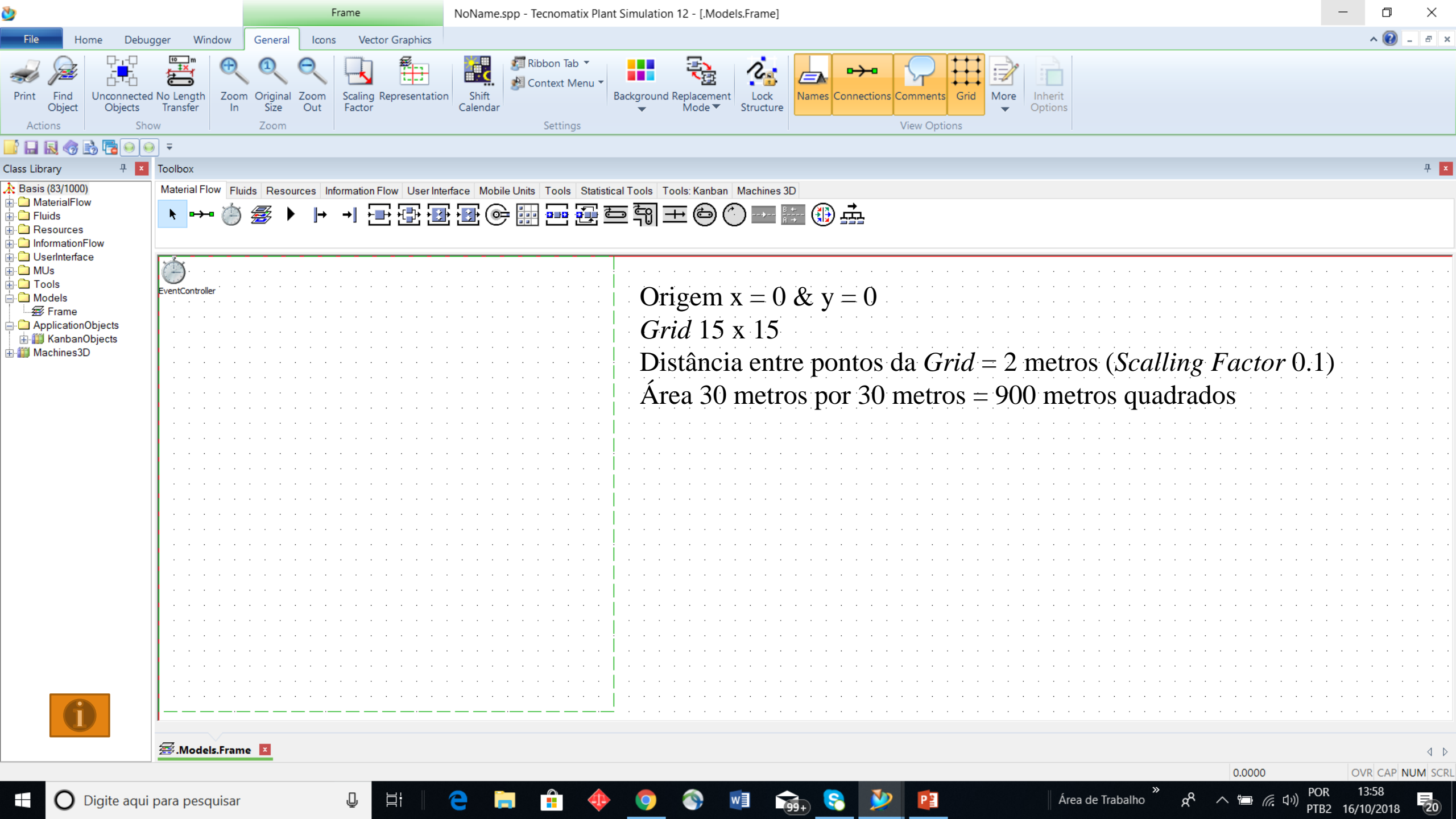
Scaling factor:

Horizontal grid spacing: 2 m

Vertical grid spacing: 2 m

OK Cancel

CONFIGURAÇÃO DA ESCALA



Origem $x = 0$ & $y = 0$

Grid 15 x 15

Distância entre pontos da Grid = 2 metros (*Scaling Factor* 0.1)

Área 30 metros por 30 metros = 900 metros quadrados

Empilhadeira - *Forklift*

ROTAS

File Home Debugger Window General Icons Vector Graphics

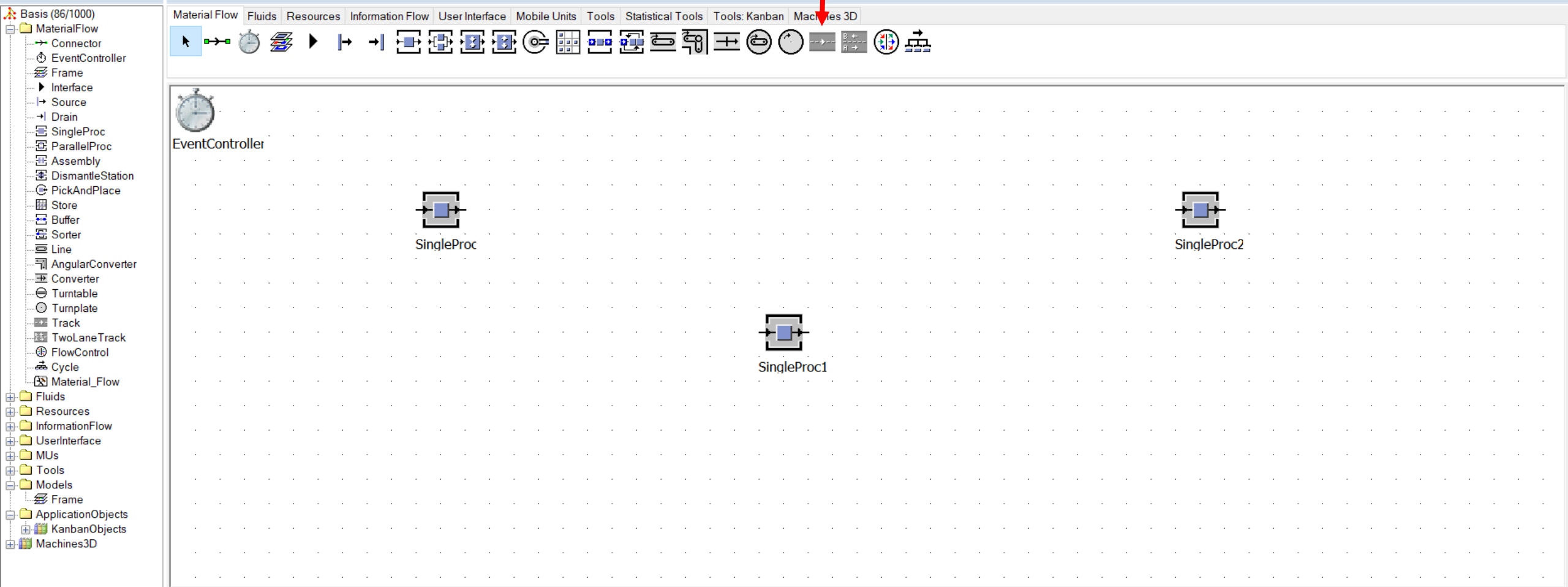
Print Find Object Unconnected Objects No Length Transfer Zoom In Original Size Zoom Out Scaling Factor Representation Shift Calendar Ribbon Tab Context Menu Background Replacement Mode Lock Structure Names Connections Comments Grid More Inherit Options

Actions Show Zoom Settings View Options

Class Library **Toolbox**

Material Flow Fluids Resources Information Flow User Interface Mobile Units Tools Statistical Tools Tools: Kanban Machines 3D

click



.Models.Frame

0.0000 OVR CAP NUM SCRL

File Home Debugger Window General Icons Vector Graphics

Print Find Object Unconnected Objects No Length Transfer Zoom In Original Size Zoom Out Scaling Factor Representation Shift Calendar Ribbon Tab Context Menu Background Replacement Mode Lock Structure Names Connections Comments Grid More Inherit Options

Actions Show Zoom Settings View Options

Class Library

Material Flow Fluids Resources Information Flow User Interface Mobile Units Tools Statistical Tools Tools: Kanban Machines 3D

MaterialFlow

- Connector
- EventController
- Frame
- Interface
- Source
- Drain
- SingleProc
- ParallelProc
- Assembly
- DismantleStation
- PickAndPlace
- Store
- Buffer
- Sorter
- Line
- AngularConverter
- Converter
- Turntable
- Turnplate
- Track
- TwoLaneTrack
- FlowControl
- Cycle
- Material_Flow

Fluids

- Resources
- InformationFlow
- UserInterface
- MUs
- Tools
- Models
- Frame
- ApplicationObjects
- KanbanObjects
- Machines3D

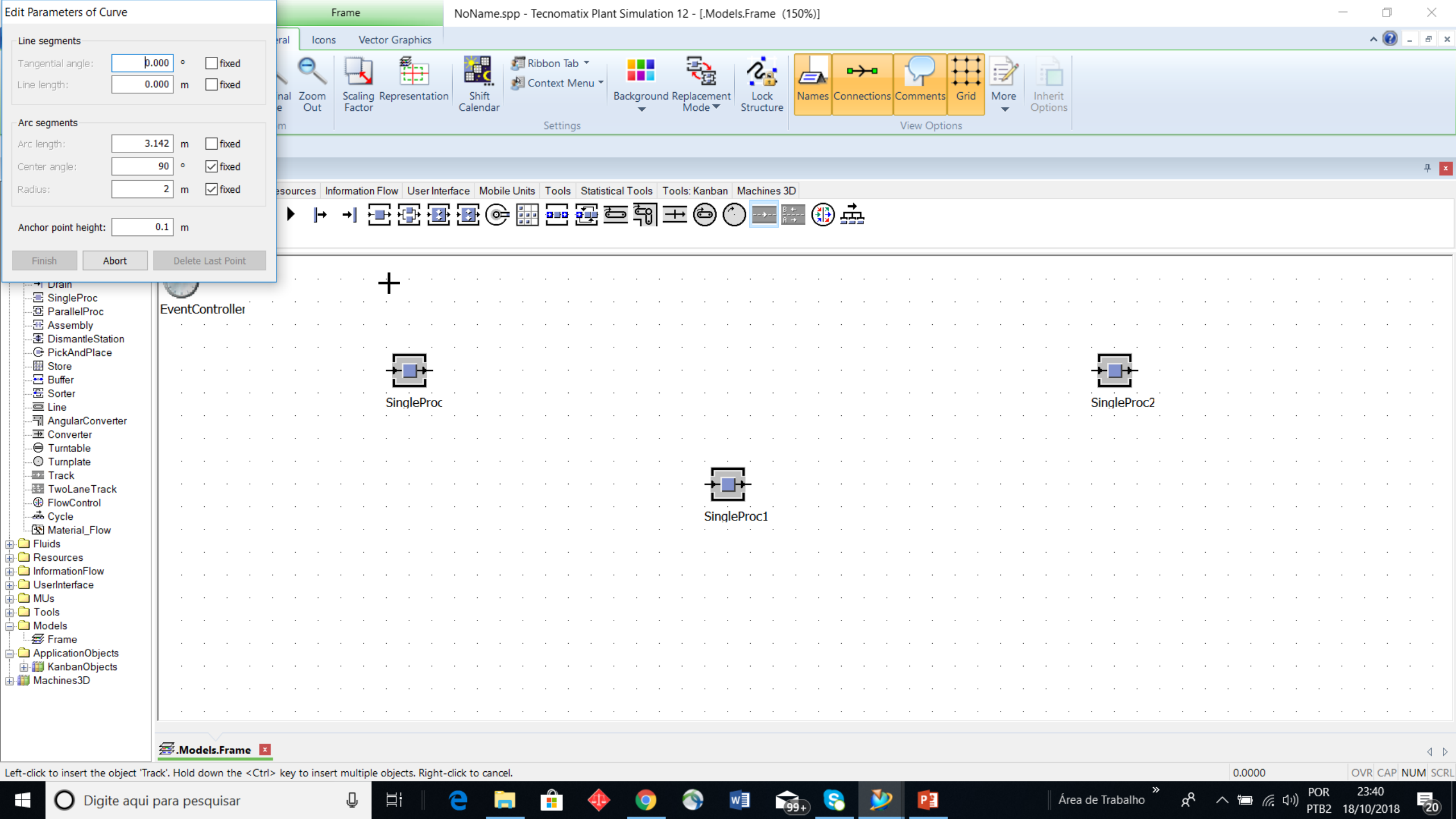
EventController

SingleProc

SingleProc1

SingleProc2

Track



Line segments

Tangential angle: ° fixed

Line length: m fixed

Arc segments

Arc length: m fixed

Center angle: ° fixed

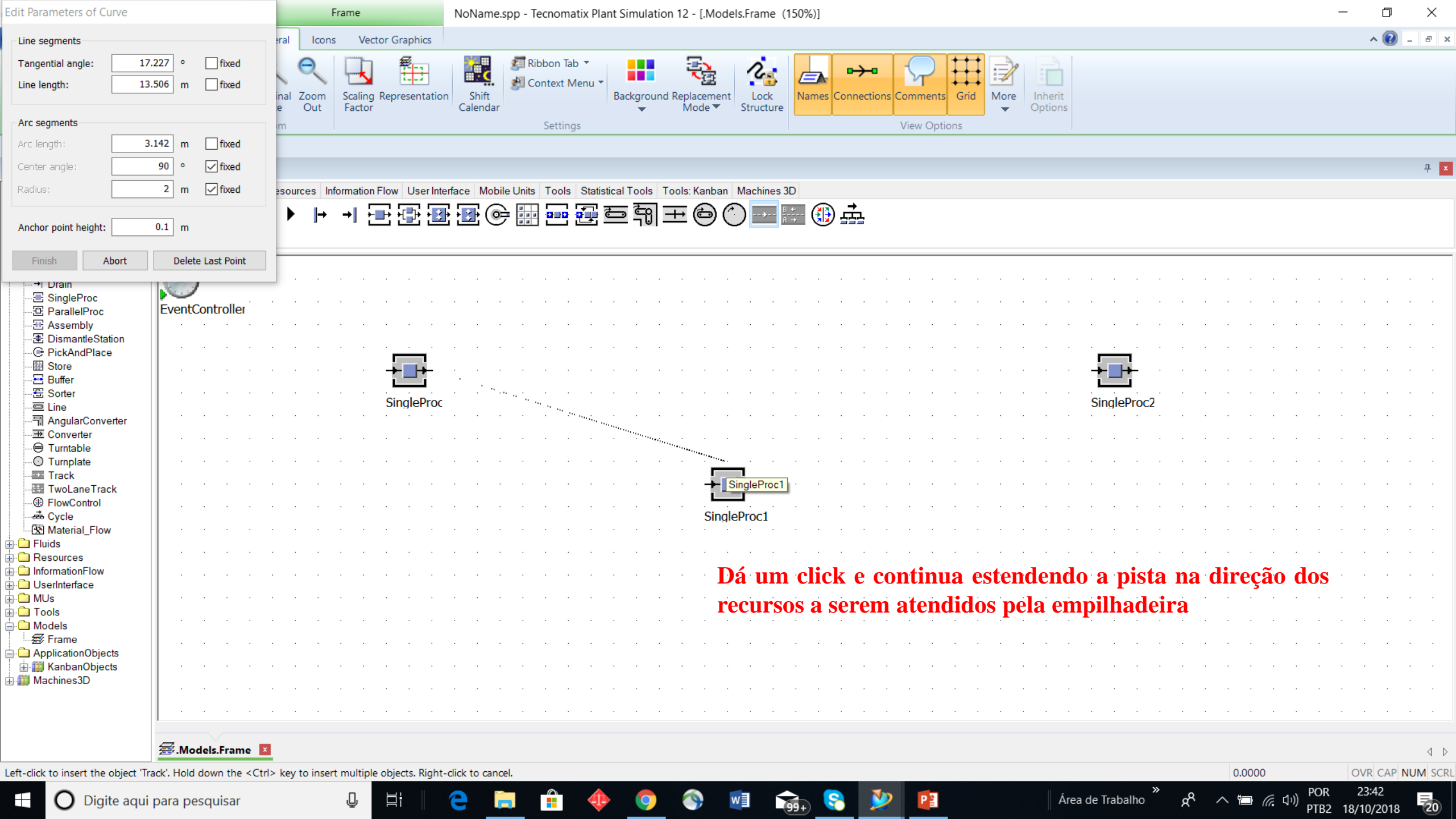
Radius: m fixed

Anchor point height: m

- Drain
- SingleProc
- ParallelProc
- Assembly
- DismantleStation
- PickAndPlace
- Store
- Buffer
- Sorter
- Line
- AngularConverter
- Converter
- Turntable
- Turnplate
- Track
- TwoLaneTrack
- FlowControl
- Cycle
- Material_Flow
- Fluids
- Resources
- InformationFlow
- UserInterface
- MUs
- Tools
- Models
- Frame
- ApplicationObjects
- KanbanObjects
- Machines3D

Left-click to insert the object 'Track'. Hold down the <Ctrl> key to insert multiple objects. Right-click to cancel.

0.0000 | OVR | CAP | NUM | SCRL



Edit Parameters of Curve

Line segments

Tangential angle: ° fixed

Line length: m fixed

Arc segments

Arc length: m fixed

Center angle: ° fixed

Radius: m fixed

Anchor point height: m

Dá um click e continua estendendo a pista na direção dos recursos a serem atendidos pela empilhadeira

Left-click to insert the object 'Track'. Hold down the <Ctrl> key to insert multiple objects. Right-click to cancel.

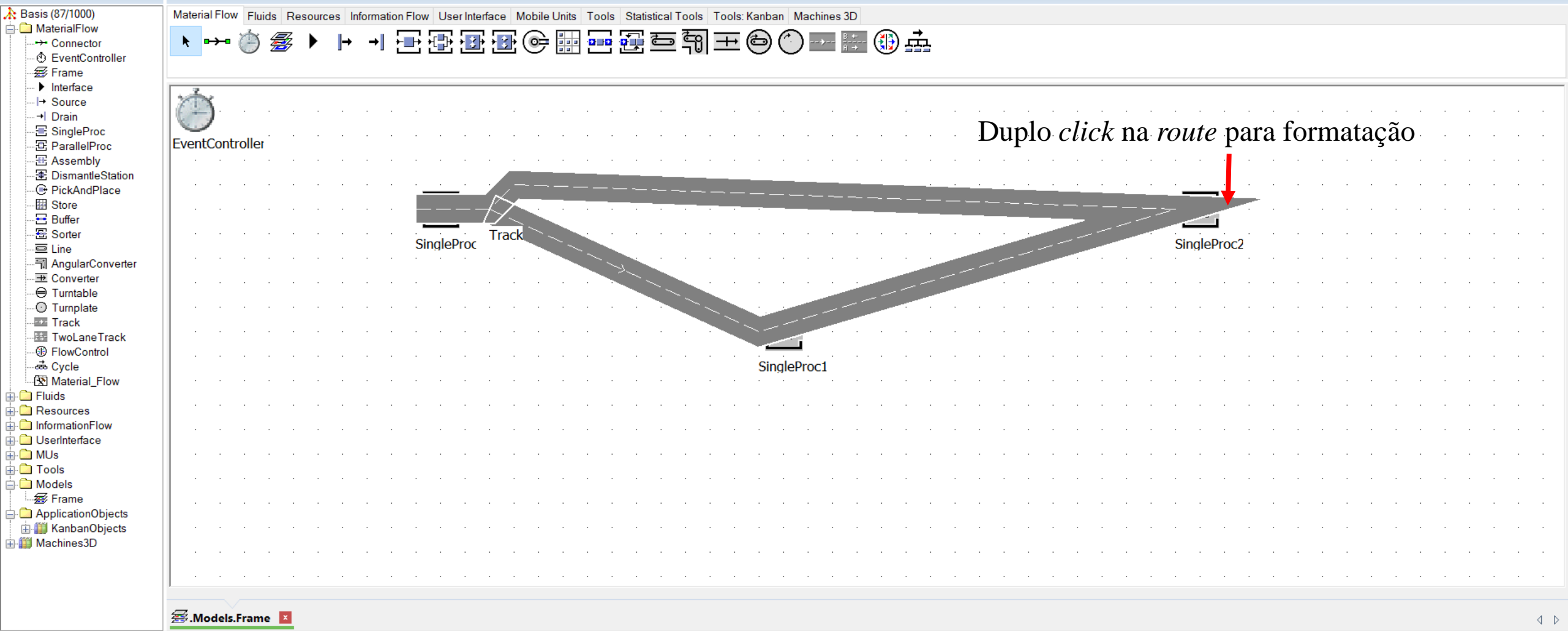
File Home Debugger Window General Icons Vector Graphics

Print Find Object Unconnected Objects No Length Transfer Zoom In Original Size Zoom Out Scaling Factor Representation Shift Calendar Ribbon Tab Context Menu Background Replacement Mode Lock Structure Names Connections Comments Grid More Inherit Options

Actions Show Zoom Settings View Options

Class Library Toolbox

Material Flow Fluids Resources Information Flow User Interface Mobile Units Tools Statistical Tools Tools: Kanban Machines 3D



.Models.Frame.Track ? X

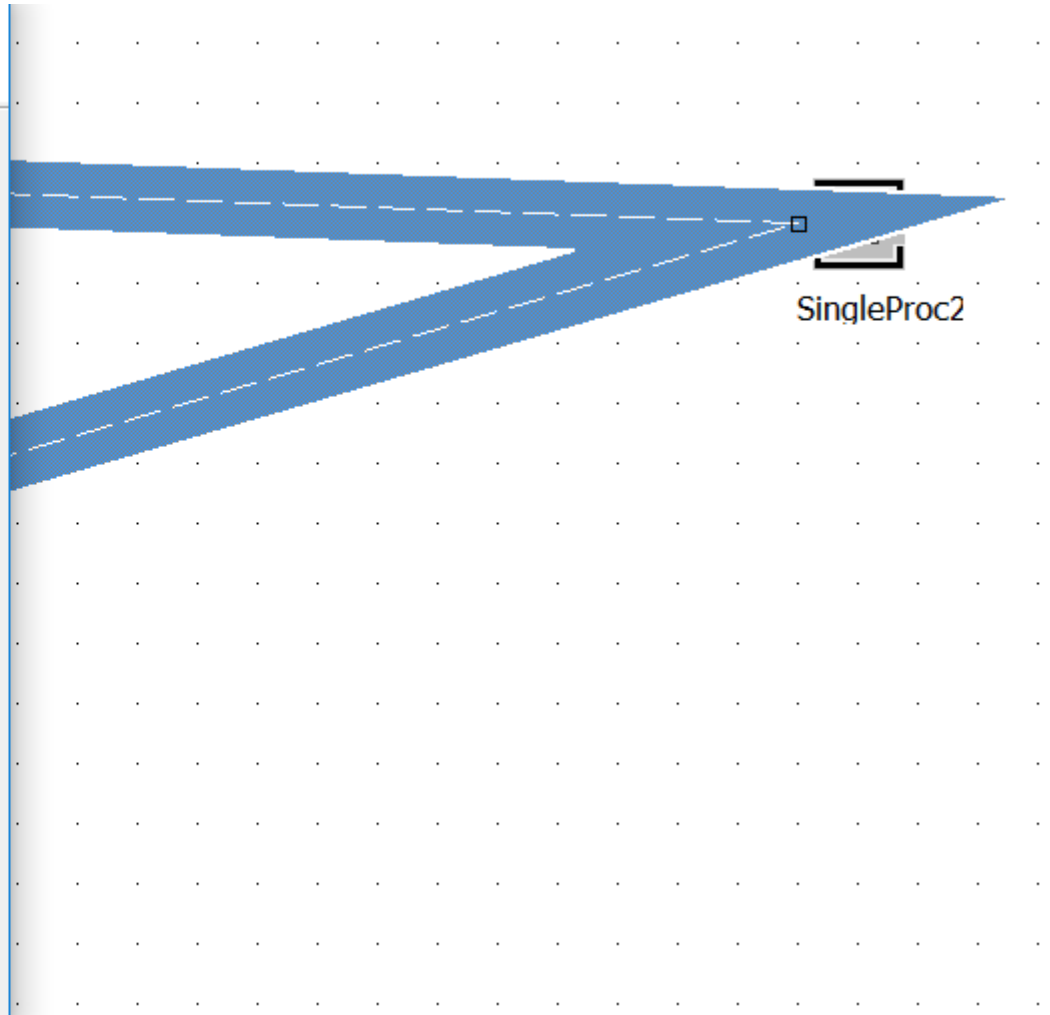
Navigate View Tools Help

Name: Failed Entrance locked
Label: Planned Exit locked

Attributes Times Failures Controls Exit Strategy Statistics **Curve** User-defin

Length: m
Capacity:
Backward destination list:
Forward destination list:

OK Cancel Apply



.Models.Frame.Track ? X

Navigate View Tools Help

Name: Track Failed Entrance locked

Label: Planned Exit locked

Attributes Times Failures Controls Exit Strategy Statistics Curve User-define

Active

Curve width: 24 Rotate movables

Pen weight: 1 Transfer length

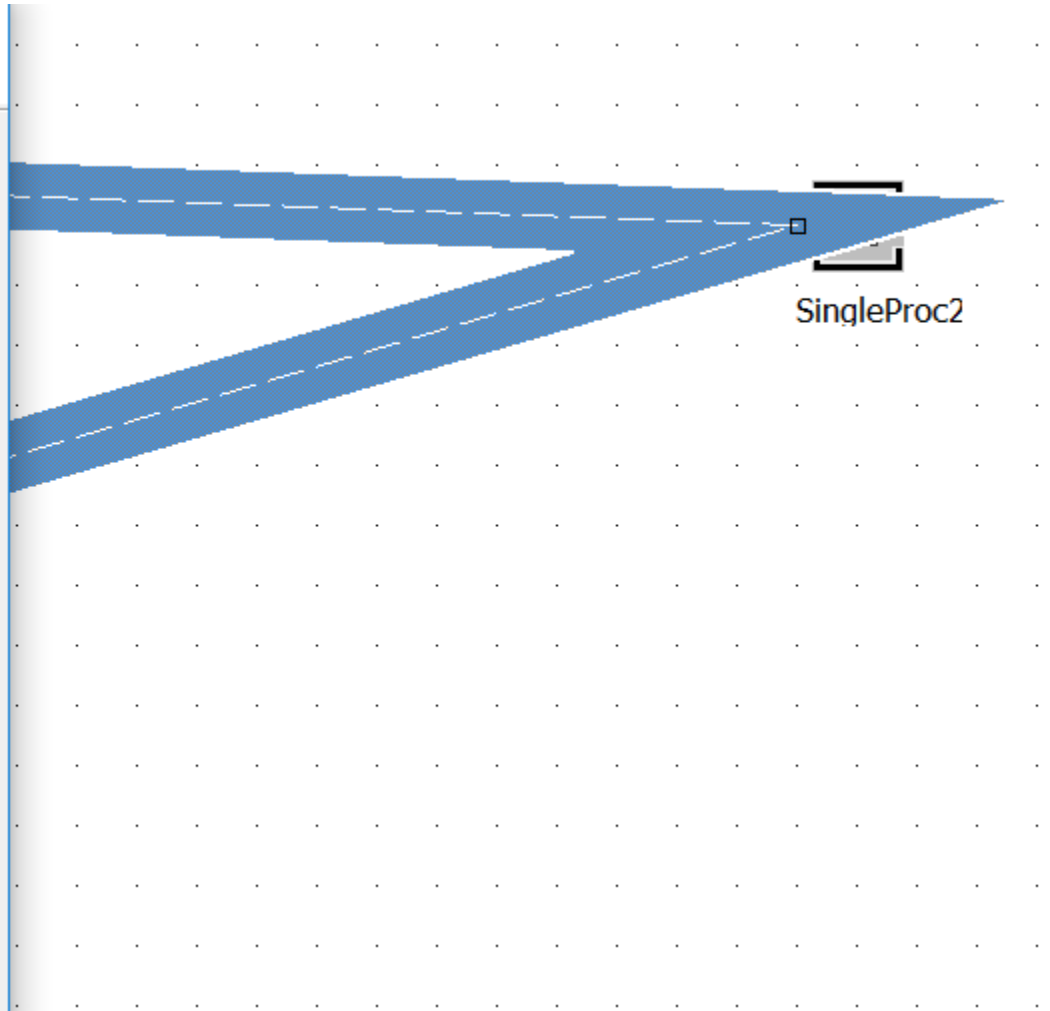
Color: Transparent

Pen color:

Midline style:

Animate every x-th pixel: 2 Segments

OK Cancel Apply



.Models.Frame.Track ? X

Navigate View Tools Help

Name: Failed Entrance locked

Label: Planned Exit locked

Attributes Times Failures Controls Exit Strategy Statistics Curve User-defined

Active

Curve width: Rotate movables

Pen weight: Transfer length

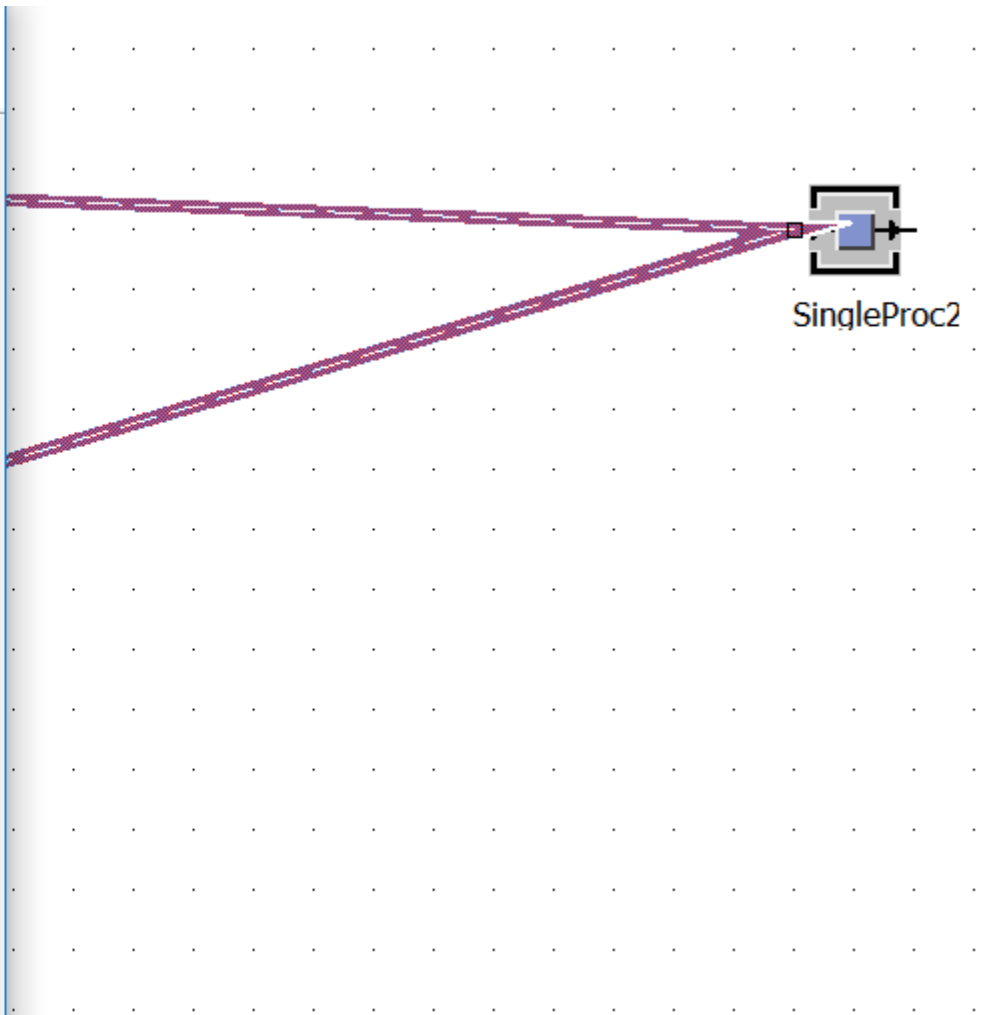
Color: Transparent

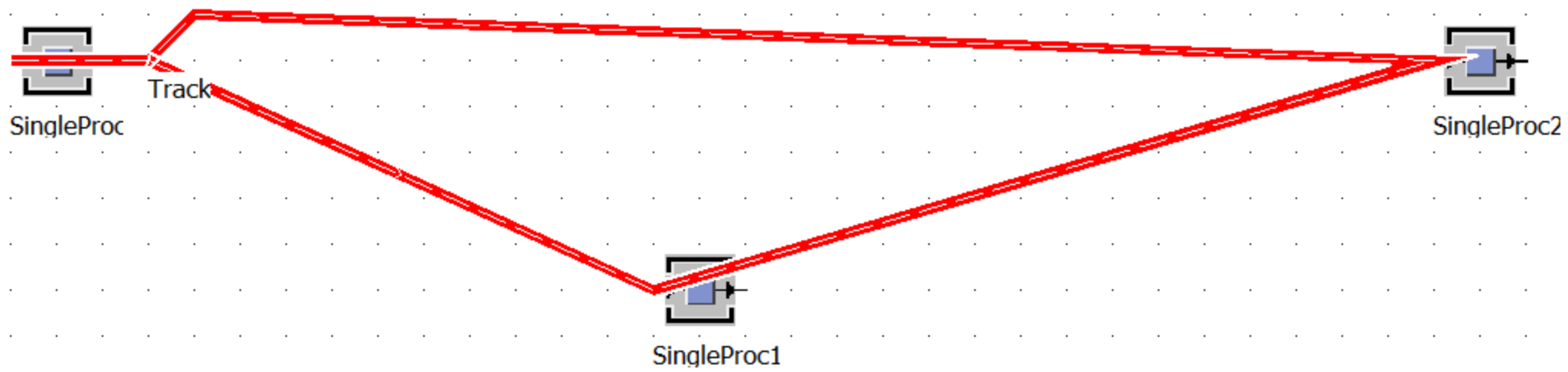
Pen color:

Midline style:

Animate every x-th pixel: Segments

OK Cancel Apply





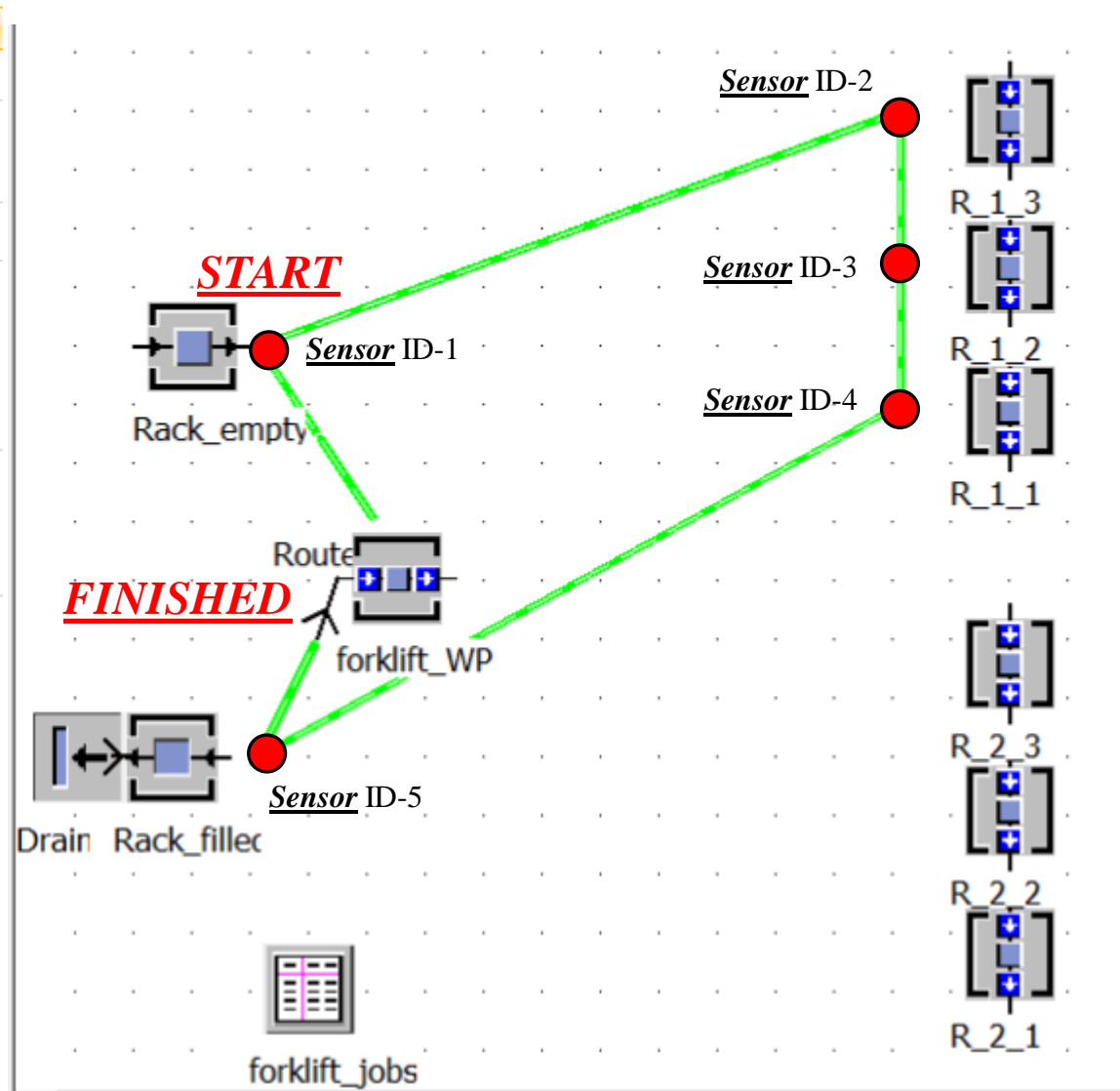
ROUTES

ROUTE 1

**** para criar um sensor posicione o cursor do *mouse* no ponto do local e *click* com o botão direito.**

Create Sensor

- Open Sensor
- Open**
- Rename... F2
- Reorder Successors
- Show Structure
- Show Statistics Report F6
- Show Attributes and Methods... F8
- Controls
- Arrange Icons
- Edit Icons... Ctrl+I
- Edit Display Panel...
- Append Points
- Delete Point
- Insert Point
- Reverse Points



Sensor-ID: 4

Position: Length

20.4 [m]

Front Rear

Activate: Always Light barrier mode

Control: self.sensorControl

OK Cancel Apply

Route 1 (início & término: Empilhadeira_WP)

➤ Start: forklift_WP – marco zero

1) Sensor ID-1 (**Rack_empty**)

Posição: 3,6 metros (*Front*)

2) Sensor ID-2 (**R_1_3**)

Posição: 15,4 metros (*Front*)

3) Sensor ID-3 (**R_1_2**)

Posição: 17,8 metros (*Front*)

4) Sensor ID-4 (**R_1_1**)

Posição: 20,4 metros (*Front*)

5) Sensor ID-5 (**Rack_filed**)

Posição: 32,8 metros (*Front*)

✓ Finished: forklift_WP – finaliza →

Sensor-ID: 4

Position: Length [v]
20.4 [m] | Front | Rear

Activate: Always [v] | Light barrier mode

Control: self.sensorControl [v]

OK Cancel Apply

Verificar número de sensores por *route*

DOIS *CLICKS* NA *ROUTE*

.Modelle.Netzwerk.Route1

Navigate View Tools Help

Name: Failed Entrance locked

Label: Planned Exit locked

Attributes Times Failures **Controls** Exit Strategy Statistics Curve User-defin...


Length: m

Capacity:

Backward destination list:

Forward destination list:

OK Cancel Apply



.Modelle.Netzwerk.Route1

Navigate View Tools Help

Name: Failed Entrance locked

Label: Planned Exit locked

Attributes Times Failures **Controls** Exit Strategy Statistics Curve User-defin...

Entrance: Front Rear

Backward entrance: Front Rear

Exit: Front Rear

Backward exit: Front Rear

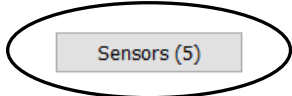
Exit control once

Pull:

Shift calendar:

Sensors (5)

OK Cancel Apply




Sensor List - .Modelle.Netzwerk.Route1

+ New... Edit... Delete

ID	Position	Front	Rear	L.	Path	C.
1	3.6m	x			self.sensorControl	*
2	15.4m	x			self.sensorControl	*
3	17.8m	x			self.sensorControl	*
4	20.4m	x			self.sensorControl	*
5	32.8m	x			self.sensorControl	*

sensorControl

ROUTE 1

(SensorID : integer; Bug : boolean)

is

do

 @ .stopped:=true;

 if SensorID=1 then

 --load empty rack

 rack_empty.cont.move(@);

 wait(warehouse_loadtime);

sensorControl

ROUTE 1

```
elseif SensorID=2 then
    --change full rack >> empty rack
    if R_1_3.cont.full then
        R_1_3.cont.move(@);
        wait(rack_loadtime);
        @.pe(1,1).cont.move(R_1_3);
    end;
```

sensorControl

ROUTE 1

```
elseif SensorID=3 and @.cont.empty then
    --change full rack >> empty rack
    if R_1_2.cont.full then
        R_1_2.cont.move(@);
        wait(rack_loadtime);
        @.pe(1,1).cont.move(R_1_2);
    end;
```

sensorControl

ROUTE 1

```
elseif SensorID=4 and @.cont.empty then
    --change full rack >> empty rack
    if R_1_1.cont.full then
        R_1_1.cont.move(@);
        wait(rack_loadtime);
        @.pe(1,1).cont.move(R_1_1);
    end;
```

sensorControl

ROUTE 1

```
elseif SensorID=5 then
  --load full to Rack_full
  @.cont.move(Rack_filled);
  wait(warehouse_loadtime);
```

```
end;
```

```
@.stopped:=false;
```

```
end;
```

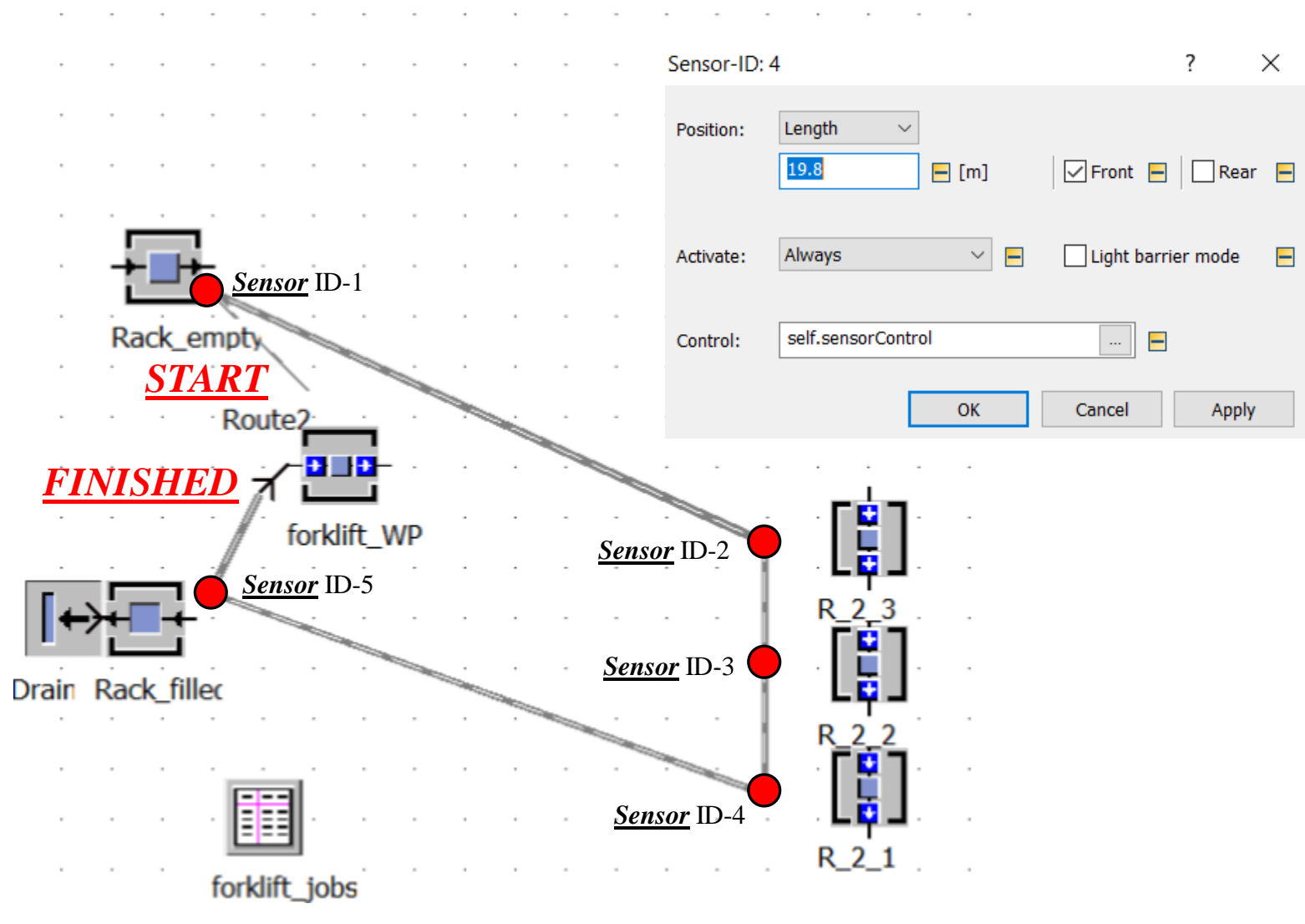


ROUTE 2

**** para criar um sensor posicione o cursor do *mouse* no ponto do local e *click* com o botão direito.**

Create Sensor

- Open Sensor
- Open
- Rename... F2
- Reorder Successors
- Show Structure
- Show Statistics Report F6
- Show Attributes and Methods... F8
- Controls
- Arrange Icons
- Edit Icons... Ctrl+I
- Edit Display Panel...
- Append Points
- Delete Point
- Insert Point
- Reverse Points



Route 2 (início & término: Empilhadeira_WP)

➤ Start: forklift_WP – marco zero

1) Sensor ID-1 (**Rack_empty**)

Posição: 2,8 metros (*Front*)

2) Sensor ID-2 (**R_2_3**)

Posição: 15,0 metros (*Front*)

3) Sensor ID-3 (**R_2_2**)

Posição: 17,3 metros (*Front*)

4) Sensor ID-4 (**R_2_1**)

Posição: 19,8 metros (*Front*)

5) Sensor ID-5 (**Rack_filed**)

Posição: 31,6 metros (*Front*)

✓ Finished: forklift_WP – finaliza →

Sensor-ID: 4

? X

Position: Length [m] | Front | Rear

Activate: Always Light barrier mode

Control: self.sensorControl

OK Cancel Apply

Verificar número de sensores por *route*

DOIS *CLICKS* NA *ROUTE*

.Modelle.Netzwerk.Route2

Navigate View Tools Help

Name: Failed Entrance locked

Label: Planned Exit locked

Attributes Times Failures **Controls** Exit Strategy Statistics Curve User-defin...

Length: m

Capacity:

Backward destination list:

Forward destination list:

OK Cancel Apply

.Modelle.Netzwerk.Route2

Navigate View Tools Help

Name: Failed Entrance locked

Label: Planned Exit locked

Attributes Times Failures **Controls** Exit Strategy Statistics Curve User-defin...

Entrance: Front Rear

Backward entrance: Front Rear

Exit: Front Rear

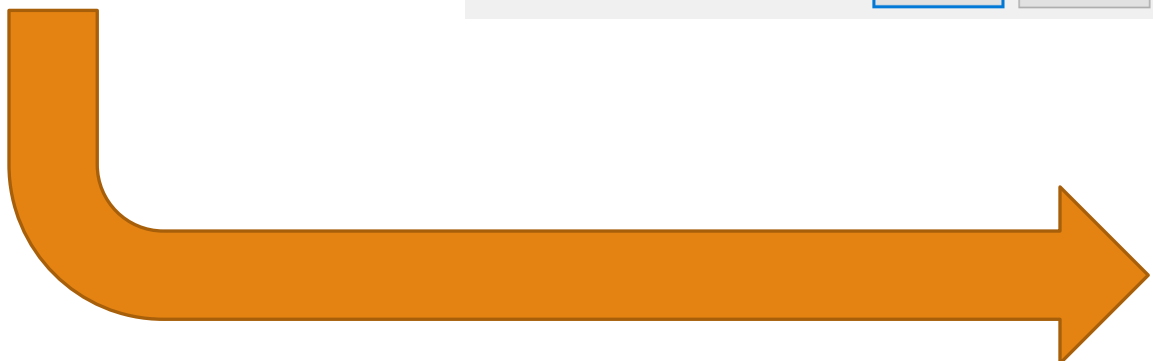
Backward exit: Front Rear

Exit control once

Pull:

Shift calendar: **Sensors (5)**

OK Cancel Apply



Sensor List - .Modelle.Netzwerk.Route2

+ New... Edit... Delete

ID	Position	Front	Rear	L.	Path	C.
1	2.8m	x			self.sensorControl	*
2	15m	x			self.sensorControl	*
3	17.3m	x			self.sensorControl	*
4	19.8m	x			self.sensorControl	*
5	31.6m	x			self.sensorControl	*

sensorControl

ROUTE 2

(SensorID : integer; Bug : boolean)

is

do

 @ .stopped:=true;

 if SensorID=1 then

 --load empty rack

 rack_empty.cont.move(@);

 wait(warehouse_loadtime);

sensorControl

ROUTE 2

```
elseif SensorID=2 then
    --change full rack >> empty rack
    if R_2_3.cont.full then
        R_2_3.cont.move(@);
        wait(rack_loadtime);
        @.pe(1,1).cont.move(R_2_3);
    end;
```

sensorControl

ROUTE 2

```
elseif SensorID=3 and @.cont.empty then
    --change full rack >> empty rack
    if R_2_2.cont.full then
        R_2_2.cont.move(@);
        wait(rack_loadtime);
        @.pe(1,1).cont.move(R_2_2);
    end;
```

sensorControl

ROUTE 2

```
elseif SensorID=4 and @.cont.empty then
    --change full rack >> empty rack
    if R_2_1.cont.full then
        R_2_1.cont.move(@);
        wait(rack_loadtime);
        @.pe(1,1).cont.move(R_2_1);
    end;
```

sensorControl

ROUTE 2

```
elseif SensorID=5 then
  --load full to Rack_full
  @.cont.move(Rack_filled);
  wait(warehouse_loadtime);
```

```
end;
```

```
@.stopped:=false;
```

```
end;
```



ROUTE 3

**** para criar um sensor posicione o cursor do *mouse* no ponto do local e *click* com o botão direito.**

Create Sensor

- Open Sensor
- Open**
- Rename... F2
- Reorder Successors
- Show Structure
- Show Statistics Report F6
- Show Attributes and Methods... F8
- Controls
- Arrange Icons
- Edit Icons... Ctrl+I
- Edit Display Panel...
- Append Points
- Delete Point
- Insert Point
- Reverse Points

Sensor-ID: 3

Position: Length [v]
66.6 [m] Front Rear

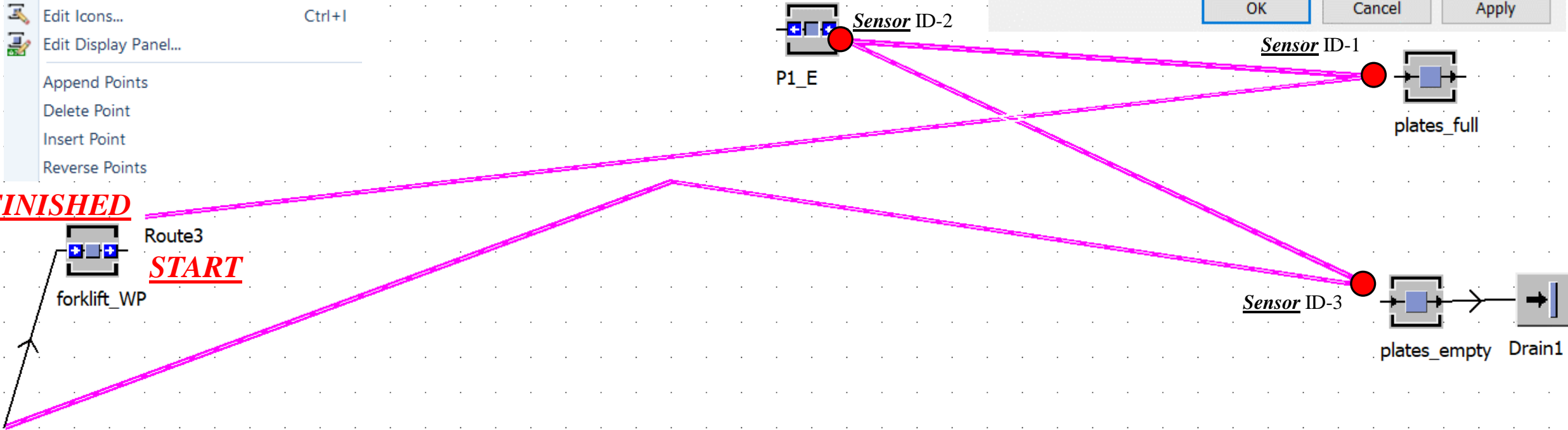
Activate: Always Light barrier mode

Control: self.sensorControl

OK Cancel Apply

FINISHED

START



Route 3 (início & término: Empilhadeira_WP)

➤ Start: forklift_WP – marco zero

1) Sensor ID-1 (*plates_full*)

Posição: 35,1 metros (*Front*)

2) Sensor ID-2 (*P1_E*)

Posição: 50,2 metros (*Front*)

3) Sensor ID-3 (*plates_empty*)

Posição: 66,6 metros (*Front*)

✓ Finished: forklift_WP – finaliza →

Sensor-ID: 3

Position: Length [v]
66.6 [m] | Front | Rear

Activate: Always [v] | Light barrier mode

Control: self.sensorControl [v]

OK Cancel Apply

Verificar número de sensores por *route*

DOIS *CLICKS* NA *ROUTE*

.Modelle.Netzwerk.Route3

Navigate View Tools Help

Name: Failed Entrance locked

Label: Planned Exit locked

Attributes Times Failures **Controls** Exit Strategy Statistics Curve User-defined

Length: m

Capacity:

Backward destination list:

Forward destination list:

OK Cancel Apply

.Modelle.Netzwerk.Route3

Navigate View Tools Help

Name: Failed Entrance locked

Label: Planned Exit locked

Attributes Times Failures **Controls** Exit Strategy Statistics Curve User-defined

Entrance: Front Rear

Backward entrance: Front Rear

Exit: Front Rear

Backward exit: Front Rear

Exit control once

Pull:

Shift calendar: **Sensors (3)**

OK Cancel Apply

Sensor List - .Modelle.Netzwerk.Route3

+ New... Edit... Delete

ID	Position	Front	Rear	L.	Path	C.
1	35.1m	x			self.sensorControl	*
2	50.2m	x			self.sensorControl	*
3	66.6m	x			self.sensorControl	*



sensorControl

ROUTE 3

(SensorID : integer; Rear : boolean)

is

do

 @ .stopped:=true;

 if sensorID=1 then

 plates_full.cont.move(@);

 wait(warehouse_loadtime);

sensorControl

ROUTE 3

```
elseif sensorID=2 then
    if P1_E.occupied then
        --change empty to full pallet
        P1_E.cont.move(@);
        @.pe(1,1).cont.move(P1_E);
    else
        --only unload
        @.pe(1,1).cont.move(P1_E);
    end;
end;
```

sensorControl

ROUTE 3

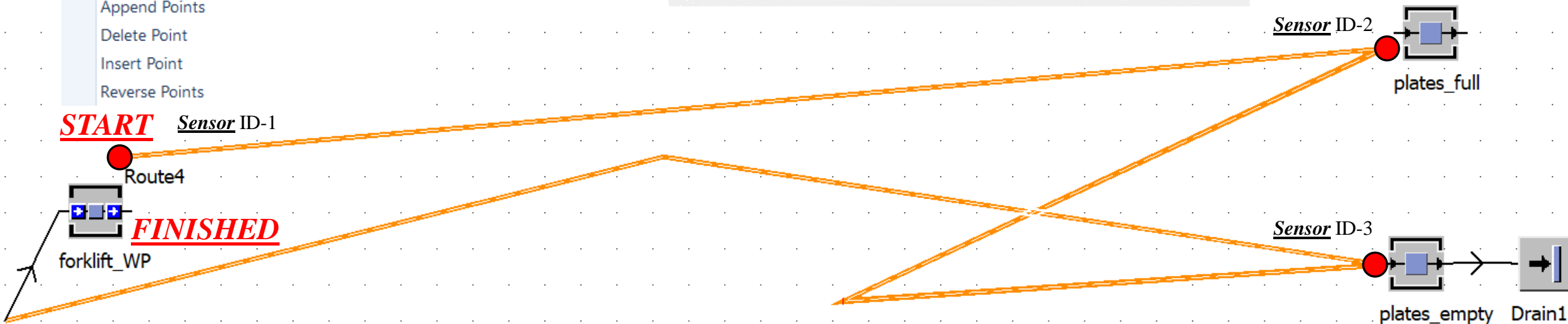
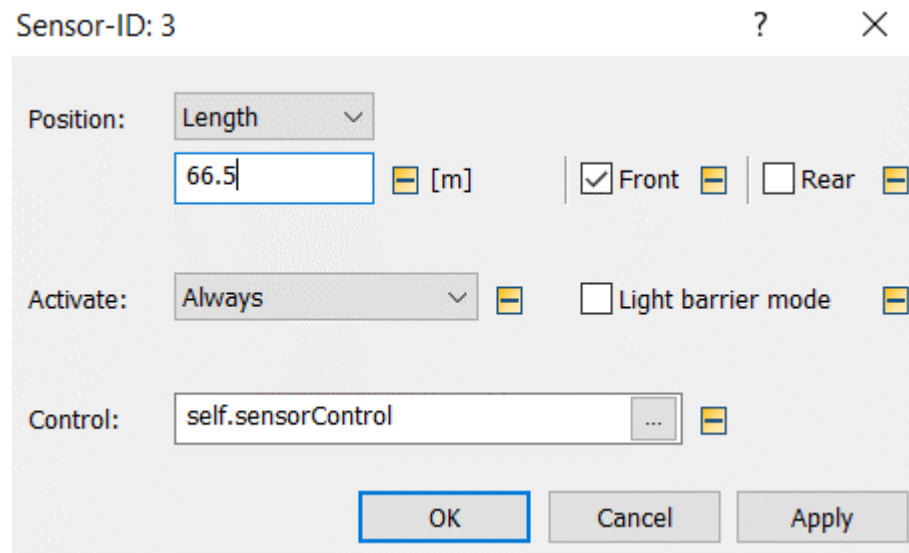
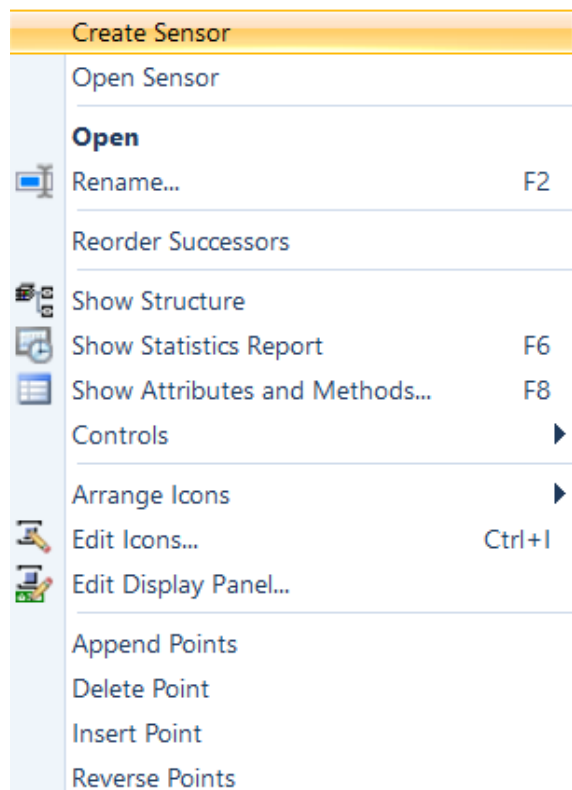
```
wait(plates_changetime);
elseif sensorID=3 then
    if @.occupied then
        @.cont.move(plates_empty);
    end;
    wait(warehouse_loadtime);
end;
@.stopped:=false;
```



```
end;
```


ROUTE 4

**** para criar um sensor posicione o cursor do *mouse* no ponto do local e *click* com o botão direito.**



Route 4 (início & término: Empilhadeira_WP)

➤ Start: forklift_WP – marco zero

1) Sensor ID-1 (*plates_full*)

Posição: 35,1 metros (*Front*)

2) Sensor ID-2 (**P2_E**)

Posição: 51,7 metros (*Front*)

3) Sensor ID-3 (*plates_empty*)

Posição: 66,5 metros (*Front*)

✓ Finished: forklift_WP – finaliza →

Sensor-ID: 3

Position: Length [v] | 66.5 [m] | Front | Rear

Activate: Always [v] | Light barrier mode

Control: self.sensorControl [v]

OK Cancel Apply

Verificar número de sensores por *route*

DOIS *CLICKS* NA *ROUTE*

.Modelle.Netzwerk.Route4

Navigate View Tools Help

Name: Failed Entrance locked

Label: Planned Exit locked

Attributes Times Failures **Controls** Exit Strategy Statistics Curve User-defin...

Length: m

Capacity:

Backward destination list:

Forward destination list:

OK Cancel Apply

.Modelle.Netzwerk.Route4

Navigate View Tools Help

Name: Failed Entrance locked

Label: Planned Exit locked

Attributes Times Failures **Controls** Exit Strategy Statistics Curve User-defin...

Entrance: Front Rear

Backward entrance: Front Rear

Exit: Front Rear

Backward exit: Front Rear

Exit control once

Pull:

Shift calendar:

Sensors (3)

OK Cancel Apply



Sensor List - .Modelle.Netzwerk.Route4

+ New... Edit... Delete

ID	Position	Front	Rear	L.	Path	C.
1	35.1m	x			self.sensorControl	*
2	51.7m	x			self.sensorControl	*
3	66.5m	x			self.sensorControl	*

sensorControl

ROUTE 4

(SensorID : integer; Rear : boolean)

is

do

 @ .stopped:=true;

 if sensorID=1 then

 plates_full.cont.move(@);

 wait(warehouse_loadtime);

sensorControl

ROUTE 4

```
elseif sensorID=2 then
    if P2_E.occupied then
        --change empty to full pallet
        P2_E.cont.move(@);
        @.pe(1,1).cont.move(P2_E);
    else
        --only unload
        @.pe(1,1).cont.move(P2_E);
    end;
end;
```

sensorControl

ROUTE 4

```
wait(plates_changetime);  
elseif sensorID=3 then  
    if @.occupied then  
        @.cont.move(plates_empty);  
    end;  
    wait(warehouse_loadtime);  
end;  
@.stopped:=false;
```



```
end;
```


ICONS

_ Empilhadeira (Forklift)

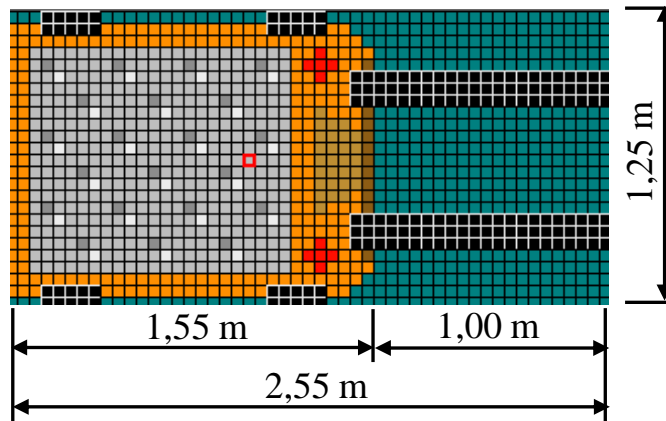
_ Pallet

_ Rack

_ Plate

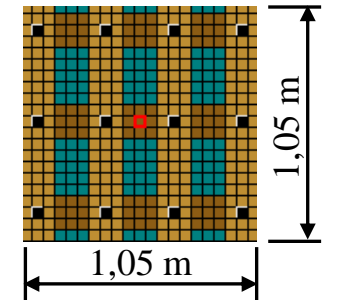
1

_ *Forklift* (2,55 m x 1,25 m)



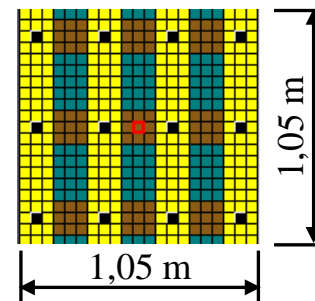
2

_ *Pallet* (1,05 m x 1,05 m)



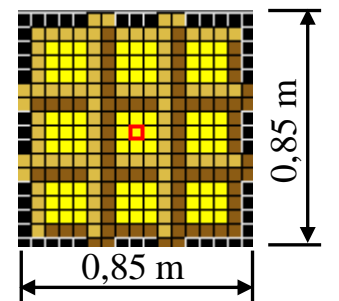
3

_ *Rack* (1,05 m x 1,05 m)



4

_ *Plate* (0,85 m x 0,85 m)

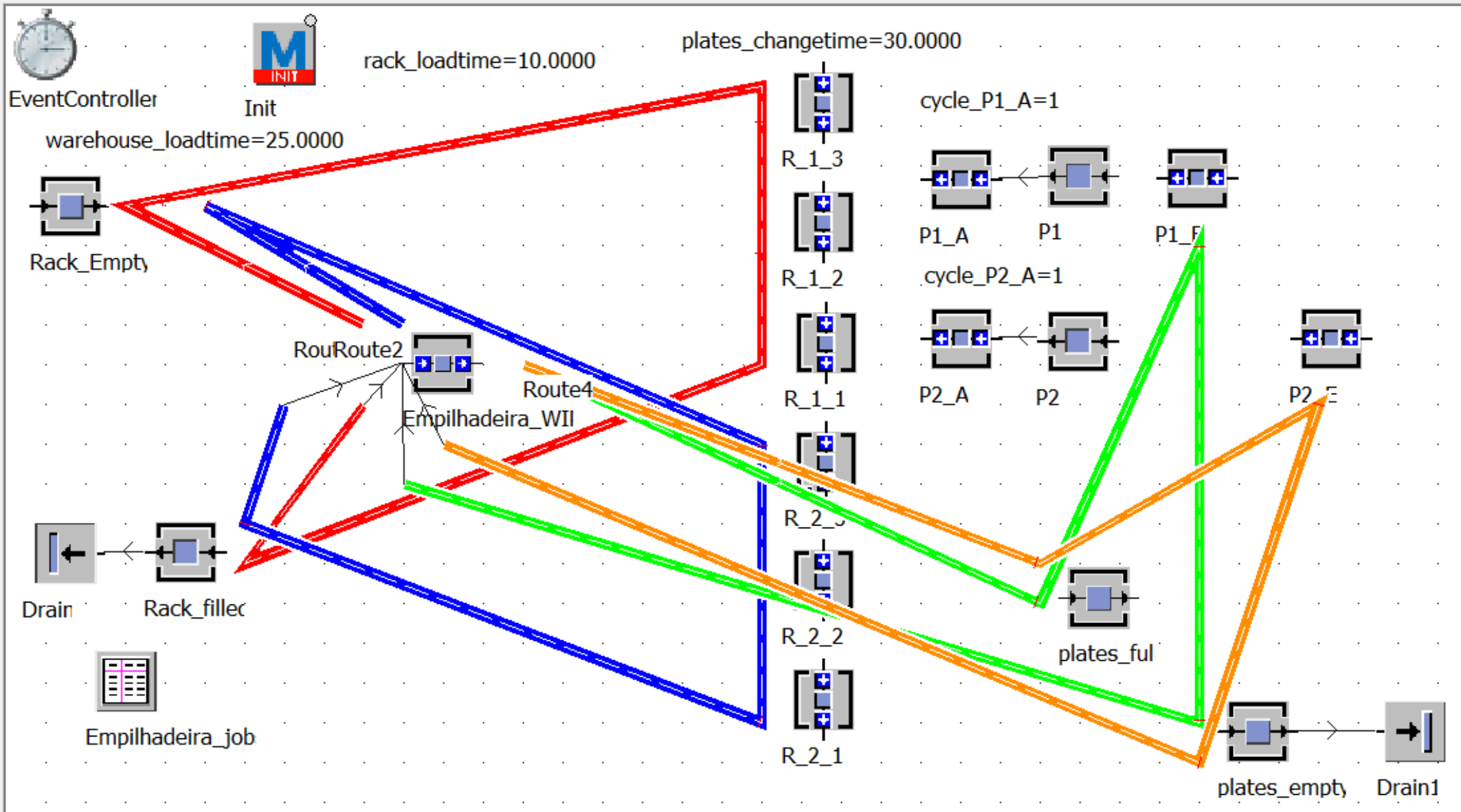


<u>Número de células</u>	<u>Dimensão em metros</u>
25 células	1,25 metros
51 células	2,55 metros
1 célula	0,05 metros

Empilhadeira - *forklift*

ICON

- InformationFlow
- Method
- Variable
- TableFile
- CardFile
- StackFile
- QueueFile
- TimeSequence
- Trigger
- Generator
- AttributeExplorer
- FileLink
- FileInterface
- XMLInterface
- Information_Flow
- INIT
- Empilhadeira_jobs
- UserInterface
- MUs
 - Entity
 - Container
 - Transporter
 - MUs
 - pallet
 - Empilhadeira**
 - Rack
 - Plate
- Tools
- Models
- Frame
- ApplicationObjects
- KanbanObjects
- Machines3D



.MUs.Empilhadeira

?

×

Navigate View Tools Help

Name: Empilhadeira

Failed

Label:

Planned

Attributes	Load Bay	Routing	Failures	Controls	Battery
Graphics	Product Statistics	Statistics	User-defined Attributes		

Vector graphics active

Color:

Border color:

Border width:

Show direction arrow

Show state

OK Cancel Apply

.MUs.Empilhadeira



Navigate View Tools Help

Name: Empilhadeira

Failed

Label:

Planned

Attributes

Load Bay

Routing

Failures

Controls

Battery

Graphics

Product Statistics

Statistics

User-defined Attributes

Vector graphics active

Color:

Border color:

Border width:

2

Show direction arrow

Show state

OK

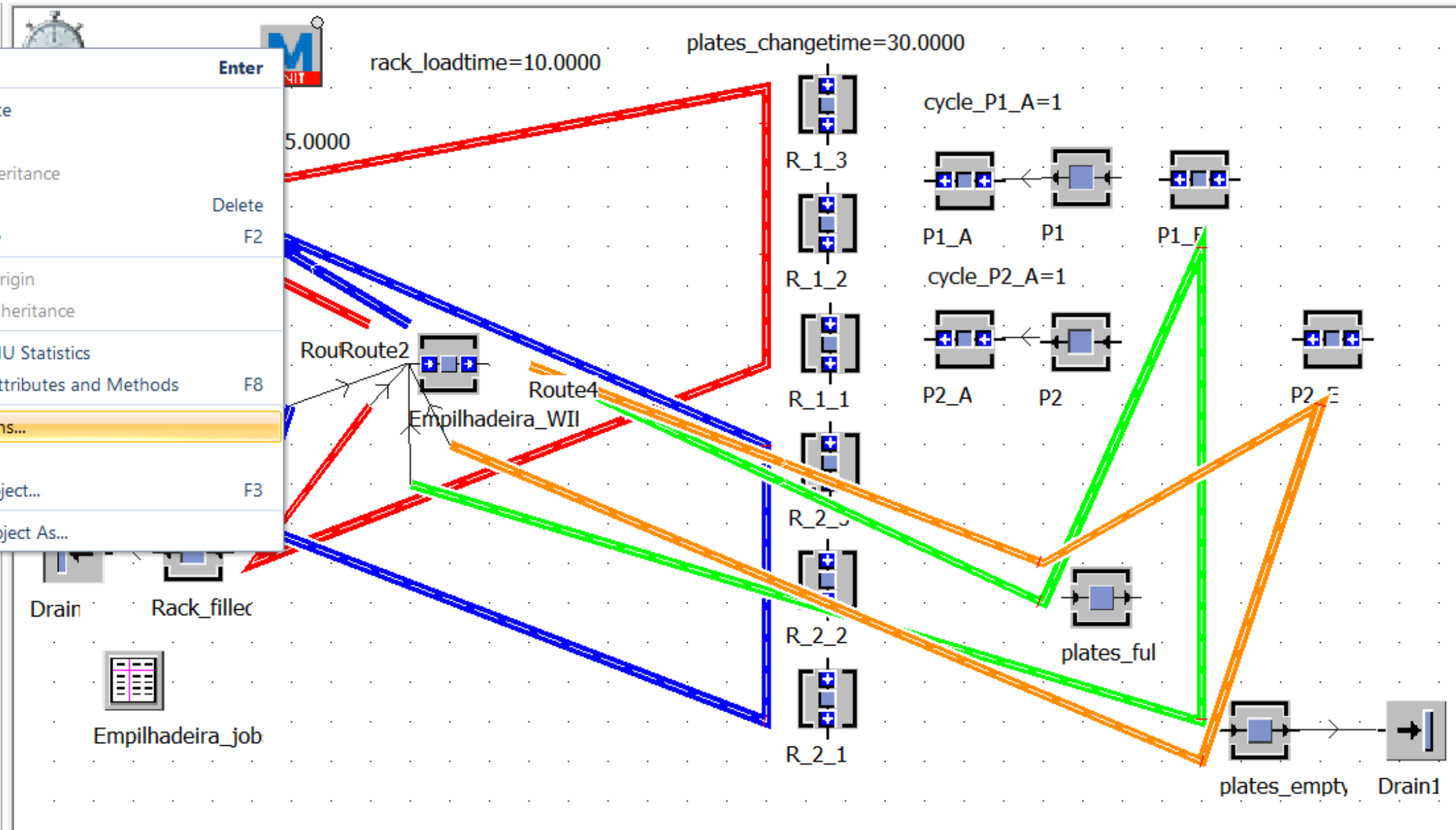
Cancel



































Apply

- Method
- Variable
- TableFile
- CardFile
- StackFile
- QueueFile
- TimeSe
- Trigger
- Generat
- Attribut
- FileLink
- FileInterf
- XMLInter
- Informati
- INIT
- Empilha
- UserInterfac
- MUs
- Entity
- Containe
- Transpo
- MUs
- pallet
- Empilhadeira
- Rack
- Plate
- Tools
- Models
- Frame
- ApplicationObjects
- KanbanObjects
- Machines3D

Open Enter

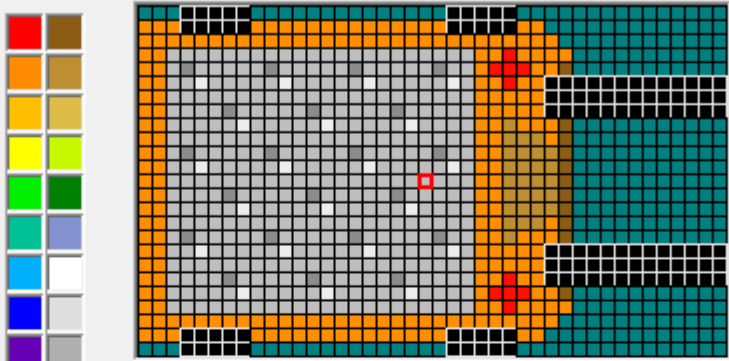
- Duplicate
- Derive
- Cut Inheritance
- Delete Delete
- Rename F2
- Show Origin
- Show Inheritance
- Show MU Statistics
- Show Attributes and Methods F8
- Edit Icons...**
- Print...
- Find Object... F3
- Save Object As...



-  Method
-  Variable
-  TableFile
-  CardFile
-  StackFile
-  QueueFile
-  TimeSequence
-  Trigger
-  Generator
-  AttributeExplorer
-  FileLink
-  FileInterface
-  XMLInterface
-  Information_Flow
-  INIT
-  Empilhadeira_jobs
-  + UI
-  - UI
-  + UI
-  - UI
-  Entity
-  Container
-  Transporter
-  MUs
-  pallet
-  Empilhadeira
-  Rack
-  Plate
-  + UI
-  - UI
-  + UI
-  - UI
-  + UI
-  + UI

Number: 0/5 Name: Current

< >



File Home Debugger Window Edit Animation General

New Import Export File
Size Transparent Settings
Apply Changes Apply
Overview Go To
Inherit Inheritance
Zoom In Zoom Out Zoom
Drawing Color Pick Color
Freehand
Line Polyline Ellipse Rectangle Filled Rectangle Fill Area Actions
Copy/Paste Area Paste Area Replace Color
Reference Point

Class Library **Set Icon Size (Ctrl+I)** Set the size of the icon.

Fluids Resources Information Flow User Interface Mobile_Units Statistical Tools Tools Tools: Kanban Machines 3D

- Basis (106/1000)
- MaterialFlow
- Fluids
- Resources
- InformationFlow
 - Method
 - Variable
 - TableFile
 - CardFile
 - StackFile
 - QueueFile
 - TimeSequence
 - Trigger
 - Generator
 - AttributeExplorer
 - FileLink
 - FileInterface
 - XMLInterface
 - Information_Flow
 - INIT
 - Empilhadeira_jobs
- UserInterface
- MUs
 - Entity
 - Container
 - Transporter
 - MUs
 - pallet
 - Empilhadeira
 - Rack
 - Plate
- Tools
- Models
- Frame
- ApplicationObjects
- KanbanObjects
- Machines3D

Navigation icons: mouse, play, stop, back, forward, search, etc.

Number: 0/5 Name: Operational Current

< >

Color palette: Red, Orange, Yellow, Green, Cyan, Blue, Purple, Black, White, Grey, Teal.

Number: 0/5 Name: Operational Current

< >

Size ? X

Pixels Length units

Width: 42 Width: 2.1 m

Height: 25 Height: 1.25 m

Scaling factor: 0.05

OK Cancel

Number: 0/5 Name: Operational Current

< > (51, 19)

Size ? X

Pixels Length units

Width: 51 Width: 2.55 m

Height: 25 Height: 1.25 m

Scaling factor: 0.05

OK Cancel

Cada célula da matriz do *Icon* corresponde a um quadrado de 0,05 m x 0,05 m

Pallet

ICON

.MUs.pallet ? X

Navigate View Tools Help

Name: pallet

Label: Conveying direction: 0 (forward)

Attributes Graphics Product Statistics Statistics User-defined Attributes

MU length:	1	m	Booking point (length):	0.5	[0..1]
MU width:	1	m	Booking point (width):	0.5	[0..1]
MU height:	1	m	Booking point (height):	0	[0..1]
X-dimension:	150				
Y-dimension:	1				
Destination:	...				

File Home Debugger Window General Icons Vector Graphics

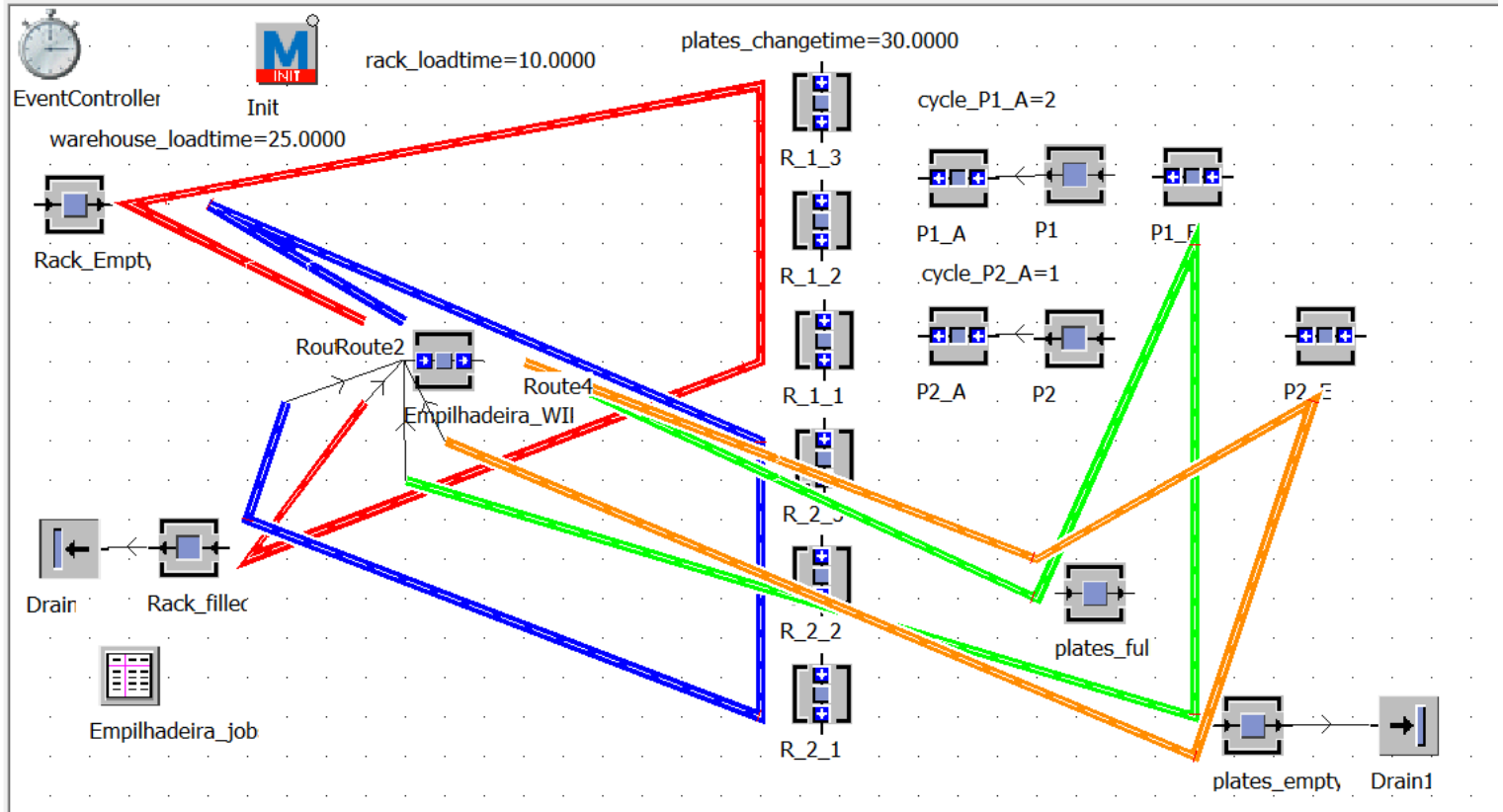
Open Event Controller Animation MU's Icons Open Location Open Origin Open Class Open 2D/3D Paste Copy Delete Select All Rename Delete MU's Icons Display Panel 3D Properties Controls Observers User-defined Attributes Statistics Methods Report Structure

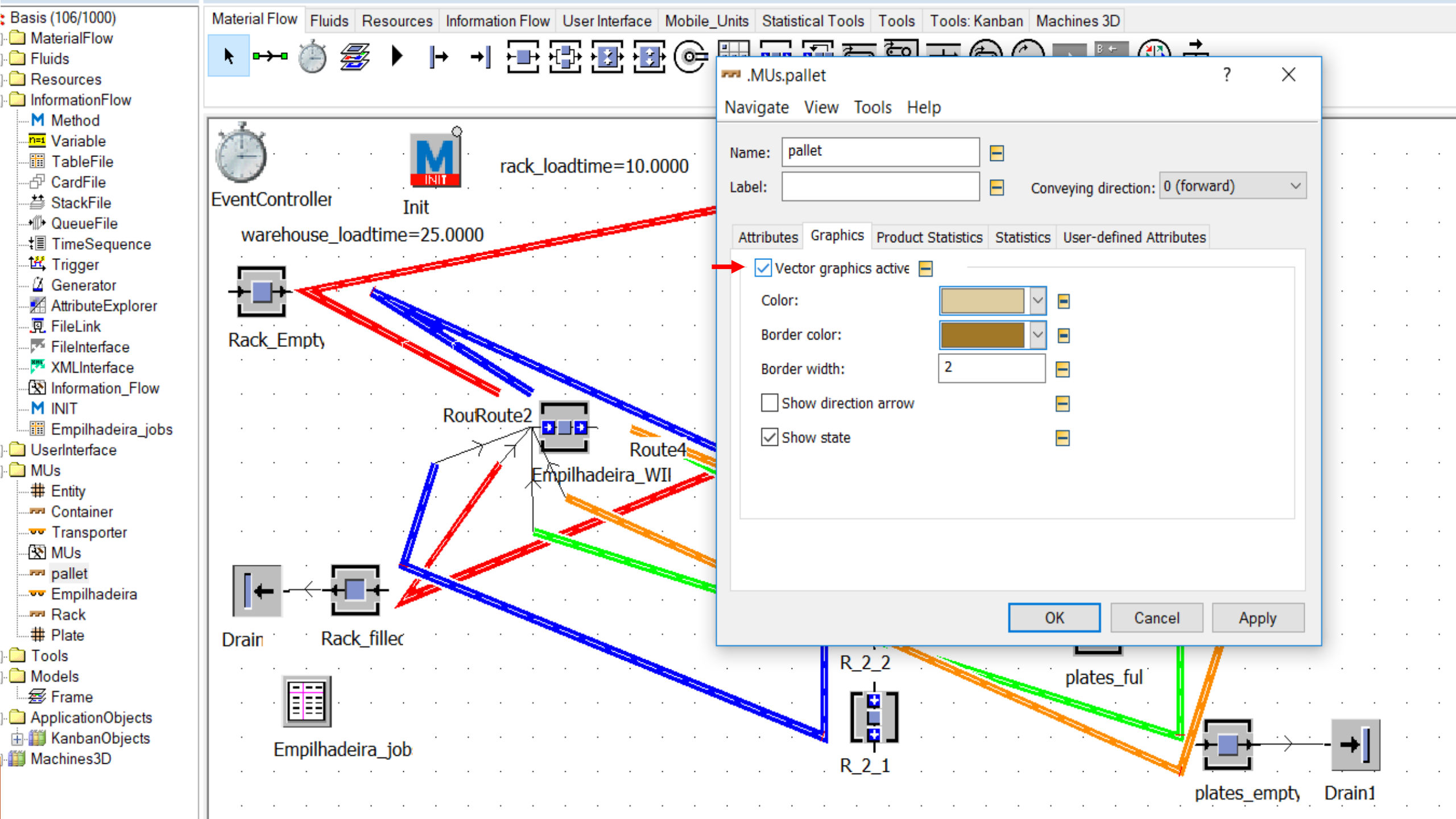
Class Library

- Basis (106/1000)
 - MaterialFlow
 - Fluids
 - Resources
 - InformationFlow
 - Method
 - Variable
 - TableFile
 - CardFile
 - StackFile
 - QueueFile
 - TimeSequence
 - Trigger
 - Generator
 - AttributeExplorer
 - FileLink
 - FileInterface
 - XMLInterface
 - Information_Flow
 - INIT
 - Empilhadeira_jobs
- UserInterface
- MUs
 - Entity
 - Container
 - Transporter
 - MUs
 - pallet
 - Empilhadeira
 - Rack
 - Plate
- Tools
- Models
- Frame
- ApplicationObjects
- KanbanObjects
- Machines3D

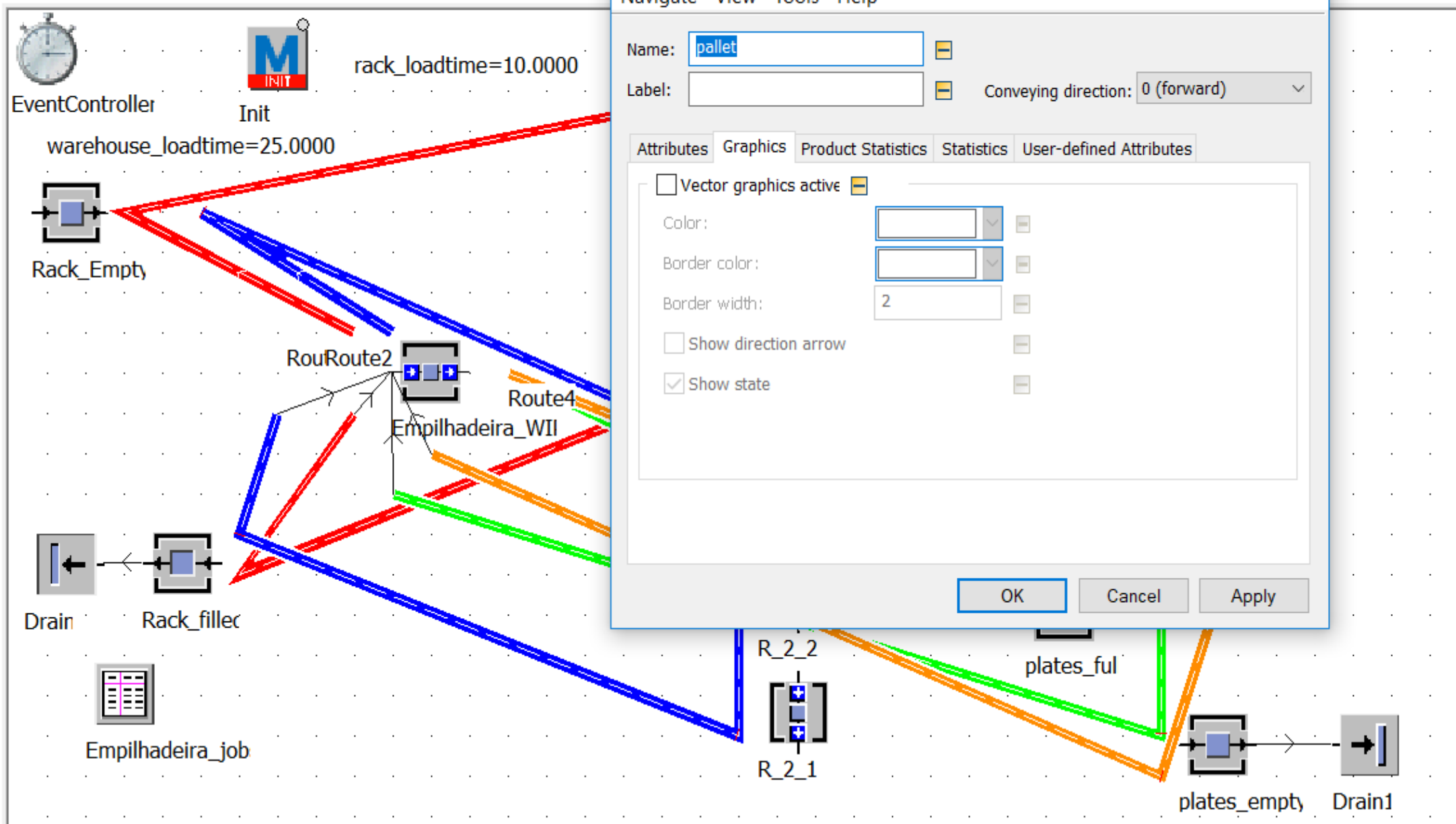
Toolbox

Material Flow Fluids Resources Information Flow User Interface Mobile Units Statistical Tools Tools Tools: Kanban Machines 3D





- Basis (106/1000)
 - MaterialFlow
 - Fluids
 - Resources
 - InformationFlow
 - Method
 - Variable
 - TableFile
 - CardFile
 - StackFile
 - QueueFile
 - TimeSequence
 - Trigger
 - Generator
 - AttributeExplorer
 - FileLink
 - FileInterface
 - XMLInterface
 - Information_Flow
 - INIT
 - Empilhadeira_jobs
 - UserInterface
 - MUs
 - Entity
 - Container
 - Transporter
 - MUs
 - pallet
 - Empilhadeira
 - Rack
 - Plate
 - Tools
 - Models
 - Frame
 - ApplicationObjects
 - KanbanObjects
 - Machines3D



.MUs.pallet ? X

Navigate View Tools Help

Name:

Label: Conveying direction: 0 (forward)

Attributes Graphics Product Statistics Statistics User-defined Attributes

Vector graphics active

Color:

Border color:

Border width:

Show direction arrow

Show state

OK Cancel Apply

- Method
- Value
- Table
- Case
- State
- Queue
- Time
- Transition
- Group
- Attribute
- File
- XML
- Initial
- IN
- Entity
- User
- MU
- Entity
- Component
- Transition
- Machine
- palette
- Empilhadeira
- Rack
- Plate
- Tools
- Models
- Frame
- ApplicationObjects
- KanbanObjects
- Machines3D

Open Enter

Duplicate

Derive

Cut Inheritance

Delete Delete

Rename F2

Show Origin

Show Inheritance

Show MU Statistics

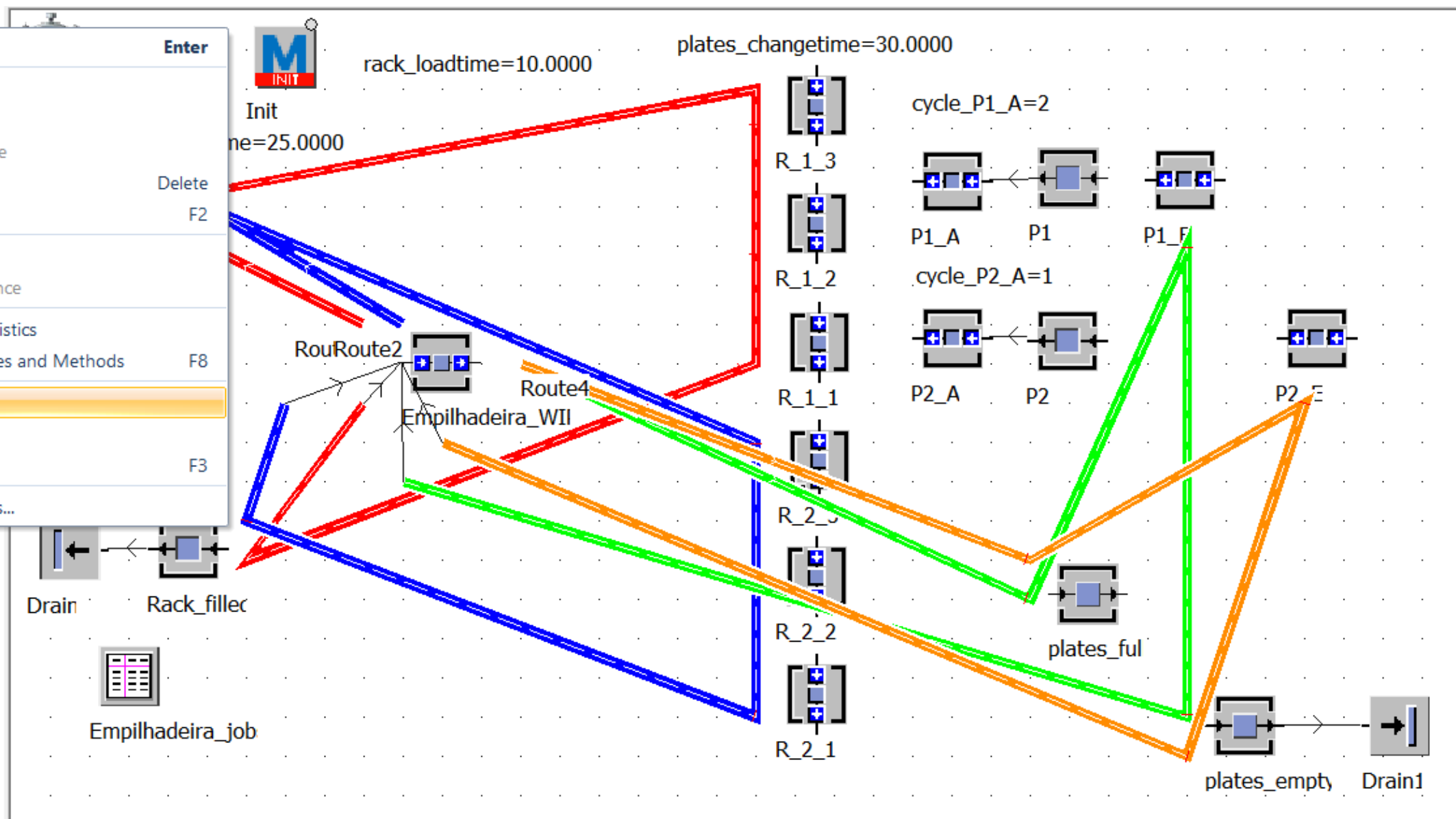
Show Attributes and Methods F8

Edit Icons...

Print...

Find Object... F3

Save Object As...



- ▲ Basis (106/1000)
 - MaterialFlow
 - Fluids
 - Resources
 - InformationFlow
 - M Method
 - Variable
 - TableFile
 - CardFile
 - StackFile
 - QueueFile
 - TimeSequence
 - Trigger
 - Generator
 - AttributeExplorer
 - FileLink
 - FileInterface
 - XMLInterface
 - Information_Flow
 - INIT
 - Empilhadeira_jobs
 - UserInterface
 - MUs
 - # Entity
 - Container
 - Transporter
 - MUs
 - pallet
 - Empilhadeira
 - Rack
 - # Plate
 - Tools
 - Models
 - Frame
 - ApplicationObjects
 - KanbanObjects
 - Machines3D

Material Flow Fluids Resources Information Flow User Interface Mobile_Units Statistical Tools Tools Tools: Kanban Machines 3D

Number: 0/2 Name: Operational Current

Empilhadeira_5.spp - Tecnomatix Plant Simulation 12 - [MUs.pallet]

File Home Debugger Window Edit Animation General


New Import Export Size Transparent Apply Changes Overview Inherit Zoom In Zoom Out Drawing Color Pick Color Freehand Line Polyline Ellipse Rectangle Filled Rectangle Fill Area Copy/Paste Area Paste Area Replace Color Reference Point

Class Library **Set Icon Size (Ctrl+I)** Set the size of the icon.


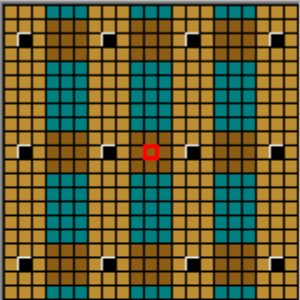
Basis (106/10) MaterialFlow Fluids Resources InformationFlow UserInterface Mobile_Units Statistical Tools Tools Tools: Kanban Machines 3D

Method Variable TableFile CardFile StackFile QueueFile TimeSequence Trigger Generator AttributeExplorer FileLink FileInterface XMLInterface Information_Flow INIT Empilhadeira_jobs UserInterface MUs Entity Container Transporter MUs pallet Empilhadeira Rack Plate Tools Models Frame ApplicationObjects KanbanObjects Machines3D

Number: 0/2 Name: Operational Current (8, 12)

Number: 0/2 Name: Current 

 (7.11)



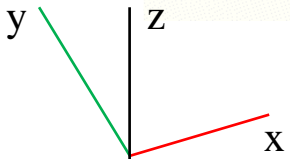
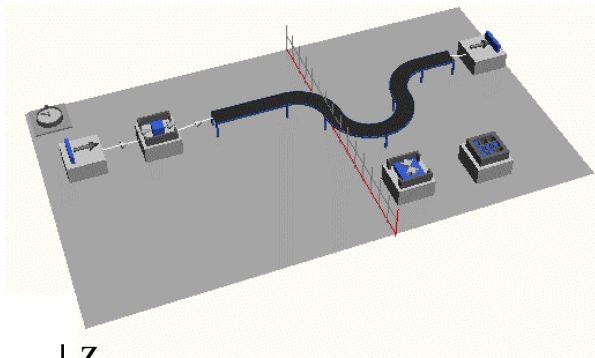
Size ? ✕

Pixels Length units

Width: Width: m

Height: Height: m

Scaling factor:



Rack

ICON

.MUs.Rack ? X

Navigate View Tools Help

Name: Rack

Label: Conveying direction: 0 (forward)

Attributes Graphics Product Statistics Statistics User-defined Attributes

MU length:	1 m	Booking point (length):	0.5 [0..1]
MU width:	1 m	Booking point (width):	0.5 [0..1]
MU height:	1 m	Booking point (height):	0 [0..1]
X-dimension:	20		
Y-dimension:	1		
Destination:	...		

OK Cancel Apply

.MUs.Rack ? X

Navigate View Tools Help

Name: Rack

Label: Conveying direction: 0 (forward)

Attributes Graphics Product Statistics Statistics User-defined Attributes

MU length:	1 m	Booking point (length):	0.5 [0..1]
MU width:	1 m	Booking point (width):	0.5 [0..1]
MU height:	1 m	Booking point (height):	0 [0..1]
X-dimension:			
Y-dimension:			
Destination:	...		

Enter the number of MUs which the object can accommodate along its x-axis. The capacity is represented by a two-dimensional net of coordinates. It is the product of Y-dimension times X-dimension.
SimTalk: XDim

OK Cancel Apply



TPH – produção por hora.

Throughput – produção.

Jornada – 24 horas por dia

Período – 50 dias

Disponibilidade – $50 * 24 = 1.200$ horas

Rack = $30.192 / 1.200 = 25,16 \cong 25$ unidades por hora

Pallet = $4.024 / 1.200 = 3,353 \cong 3$ unidades por hora

30.192 *Racks* (cada *Rack* armazena 20 *Plates*)

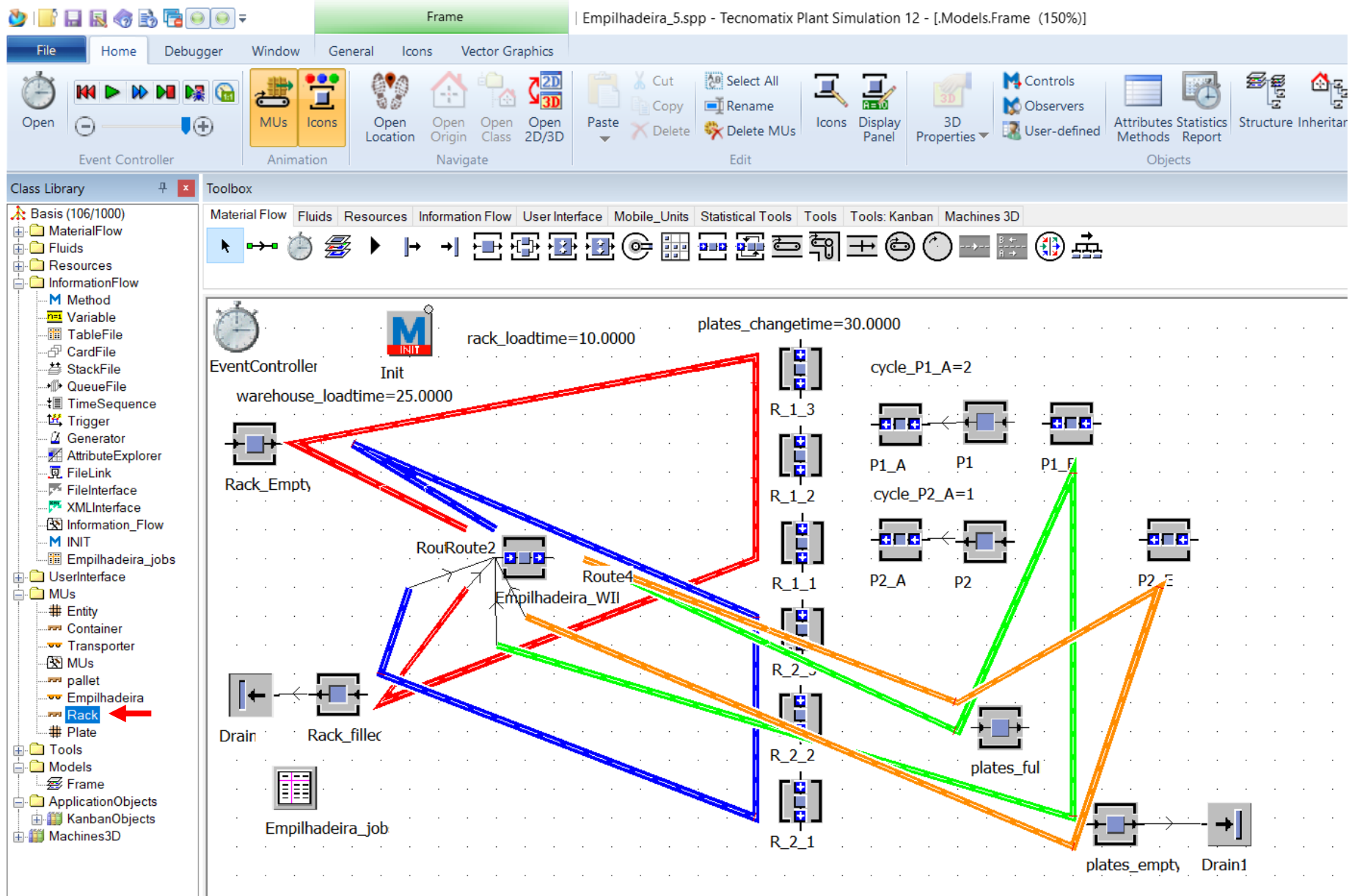
$20 * 30.192 = \mathbf{603.840 \text{ Plates.}}$

Product-Oriented Statistics of all Existing and Deleted MUs (by Classes)

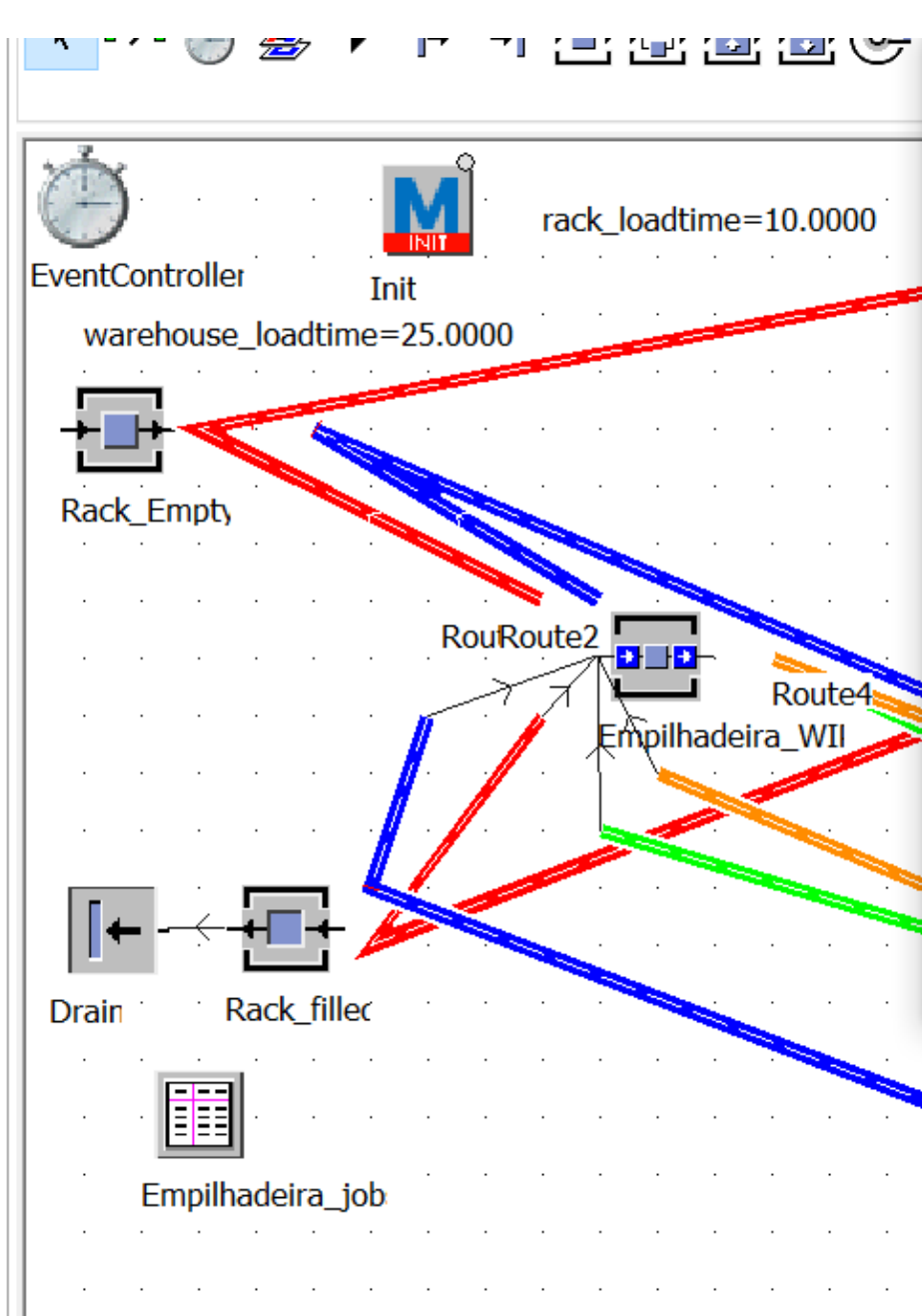
<i>Class</i>	<i>Count</i>	<i>Deleted</i>	<i>Mean Life Time</i>
<i>Plate</i>	210	603840	41:24.8238

Cumulated Statistics of the Parts which the Drain Deleted

<i>Cumulated Statistics of the Parts which the Drain Deleted</i>									
<i>Object</i>	<i>Name</i>	<i>Mean Life Time</i>	<i>Throughput</i>	<i>TPH</i>	<i>Production</i>	<i>Transport</i>	<i>Storage</i>	<i>Value added</i>	<i>Portion</i>
<u>Drain</u>	<i>Rack</i>	18:05.3374	30192	25	13.18%	8.65%	78.17%	0.00%	
<u>Drain1</u>	<i>pallet</i>	55:00.0839	4024	3	32.50%	2.47%	65.03%	0.00%	



- Fluor
- Resources
- InformationFlow
 - Method
 - Variable
 - TableFile
 - CardFile
 - StackFile
 - QueueFile
 - TimeSequence
 - Trigger
 - Generator
 - AttributeExplorer
 - FileLink
 - FileInterface
 - XMLInterface
 - Information_Flow
 - INIT
 - Empilhadeira_jobs
- UserInterface
- MUs
 - Entity
 - Container
 - Transporter
 - MUs
 - pallet
 - Empilhadeira
 - Rack
 - Plate
- Tools
- Models
 - Frame
- ApplicationObjects
- KanbanObjects
- Machines3D



.MUs.Rack

Navigate View Tools Help

Name: Rack

Label:

Conveying direction: 0 (forward)

Attributes Graphics Product Statistics Statistics User-defined Attributes

Vector graphics active

Color: [Color Picker]

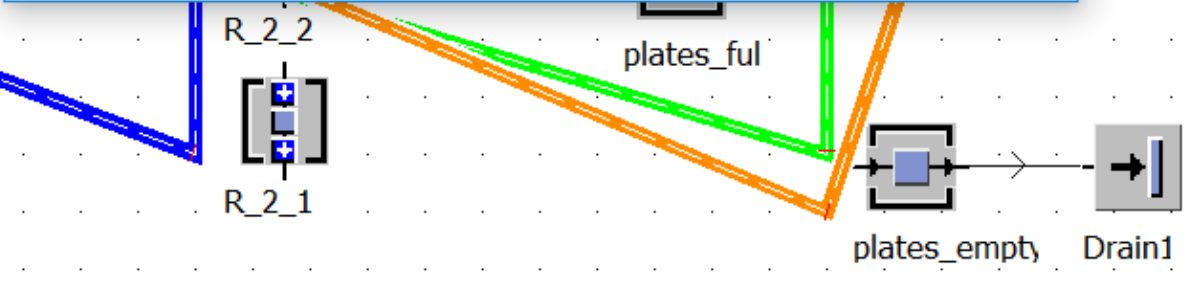
Border color: [Color Picker]

Border width: 2

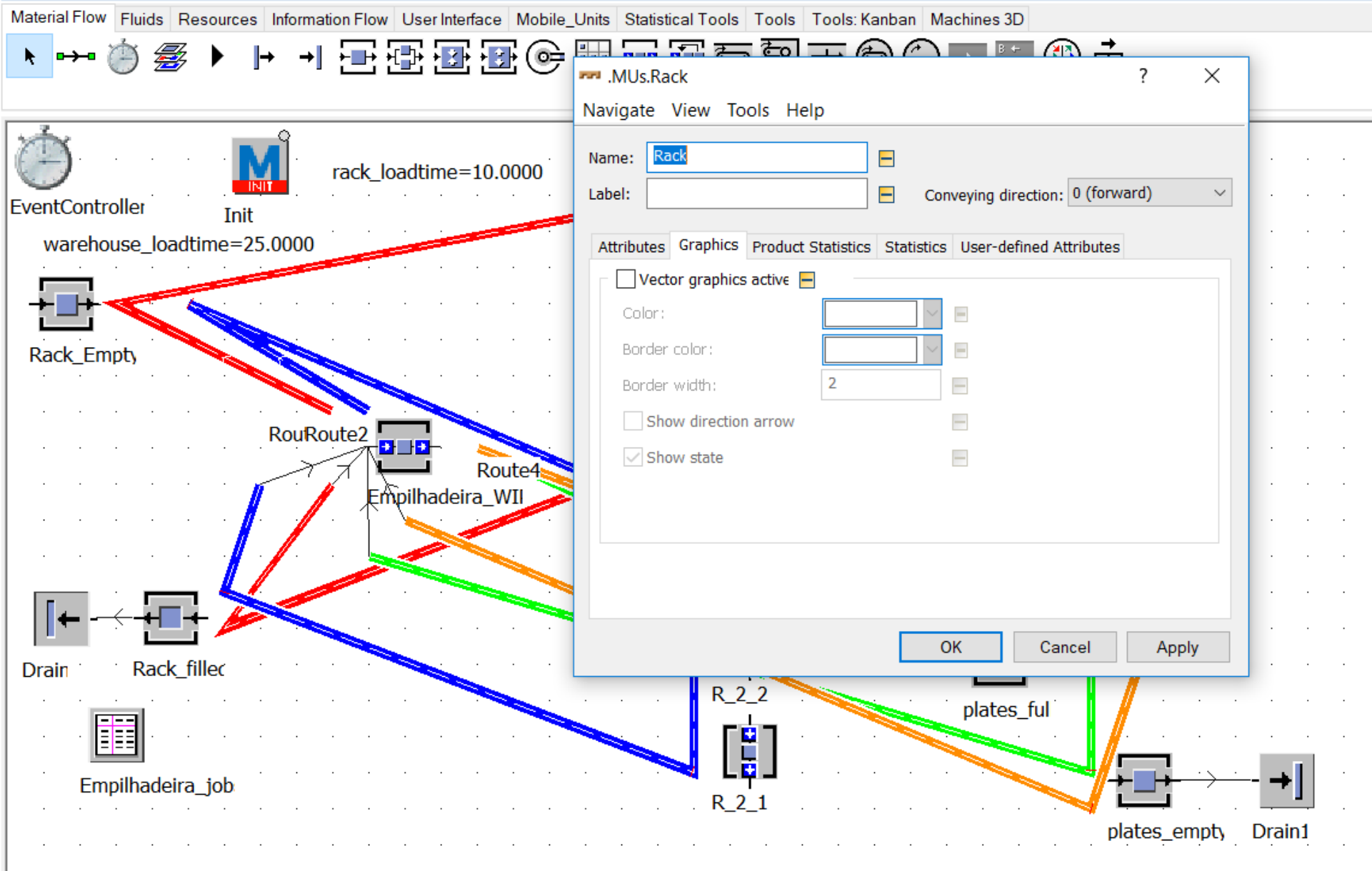
Show direction arrow

Show state

OK Cancel Apply



- Basis (106/1000)
 - MaterialFlow
 - Fluids
 - Resources
 - InformationFlow
 - Method
 - Variable
 - TableFile
 - CardFile
 - StackFile
 - QueueFile
 - TimeSequence
 - Trigger
 - Generator
 - AttributeExplorer
 - FileLink
 - FileInterface
 - XMLInterface
 - Information_Flow
 - INIT
 - Empilhadeira_jobs
 - UserInterface
 - MUs
 - Entity
 - Container
 - Transporter
 - MUs
 - pallet
 - Empilhadeira
 - Rack
 - Plate
 - Tools
 - Models
 - Frame
 - ApplicationObjects
 - KanbanObjects
 - Machines3D



- M Method
- n=1 Variable
- TableFile
- Car
- Sta
- Qu
- Tim
- Tri
- Ge
- Attr
- File
- File
- XM
- Info
- M INI
- Em
- UserIn
- MUs
- # Ent
- Co
- Tr
- MU
- pal
- Em
- Rack
- # Plate
- Tools
- Models
- Frame
- ApplicationObjects
- KanbanObjects
- Machines3D

Open Enter

Duplicate

Derive

Cut Inheritance

Delete Delete

Rename F2

Show Origin

Show Inheritance

Show MU Statistics

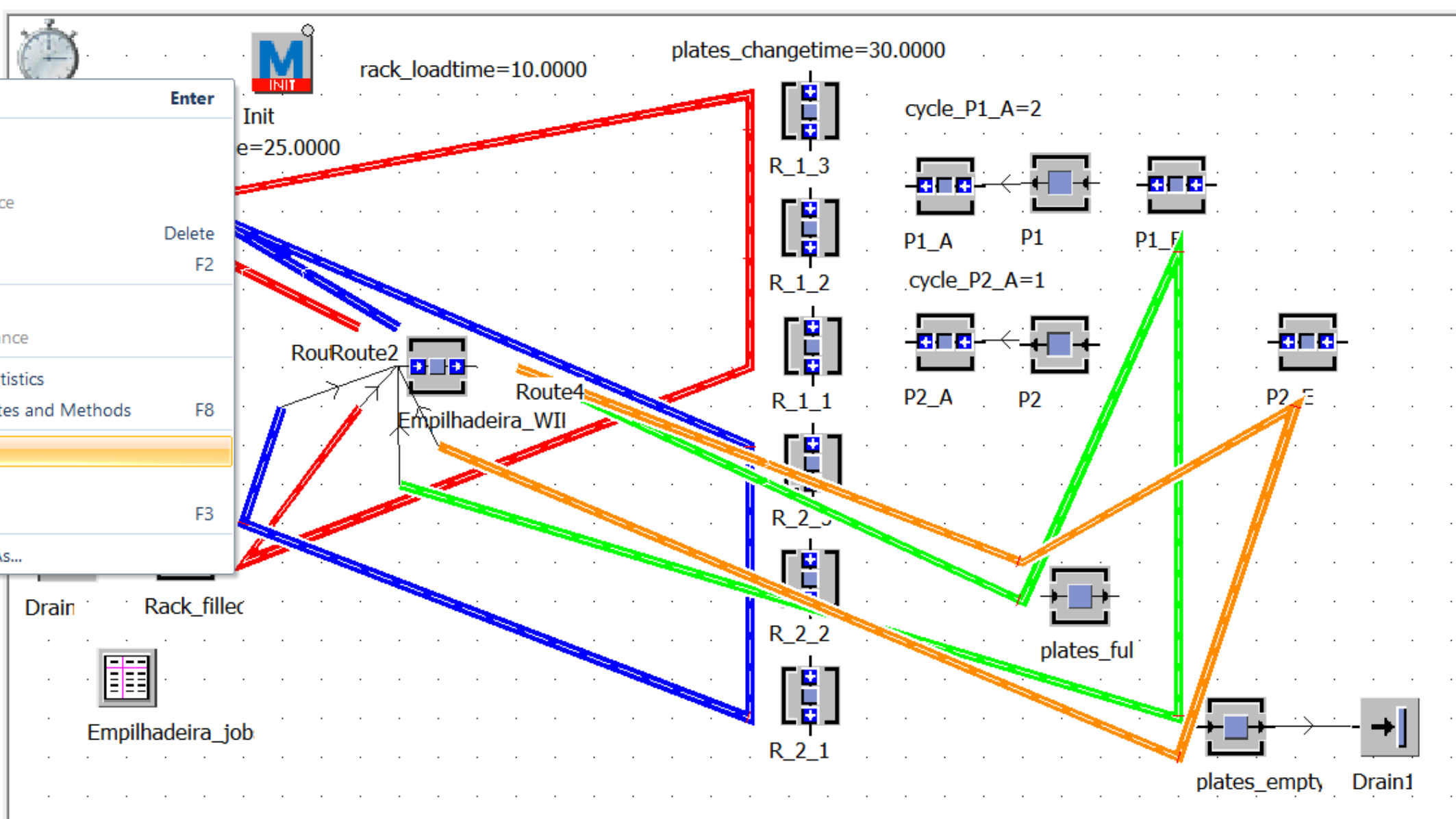
Show Attributes and Methods F8

Edit Icons...

Print...

Find Object... F3

Save Object As...



- metnoa
- Variable
- TableFile
- CardFile
- StackFile
- QueueFile
- TimeSequence
- Trigger
- Generator
- AttributeExplorer
- FileLink
- FileInterface
- XMLInterface
- Information_Flow
- INIT
- Empilhadeira_jobs
- Folder: UI
 - Folder: MUs
 - Entity
 - Container
 - Transporter
 - MUs
 - pallet
 - Empilhadeira
 - Rack
 - Plate
- Folder: Tools
 - Folder: Models
 - Frame
- Folder: ApplicationObjects
 - KanbanObjects
 - Machines3D

Number: 0/2
Name:
 Current

<
>

File Home Debugger Window Edit Animation General

New Import Export File

Size Transparent Settings

Apply Changes Apply

Overview Go To

Inherit Inheritance

Zoom In Zoom Out Zoom

Drawing Color Pick Color

Freehand

Line Polyline Ellipse Rectangle Filled Rectangle Fill Area Actions

Copy/Paste Area Paste Area Replace Color Reference Point

Class Library

- Basis (106/10)
- MaterialFlow
- Fluids
- Resources
- InformationFlow
 - Method
 - Variable
 - TableFile
 - CardFile
 - StackFile
 - QueueFile
 - TimeSequence
 - Trigger
 - Generator
 - AttributeExplorer
 - FileLink
 - FileInterface
 - XMLInterface
 - Information_Flow
 - INIT
 - Empilhadeira_jobs
- UserInterface
- MUs
 - Entity
 - Container
 - Transporter
 - MUs
 - pallet
 - Empilhadeira
 - Rack
 - Plate
- Tools
- Models
 - Frame
- ApplicationObjects
 - KanbanObjects
 - Machines3D


Set Icon Size (Ctrl+I)
Set the size of the icon.

Fluids Resources Information Flow User Interface Mobile_Units Statistical Tools Tools Tools: Kanban Machines 3D


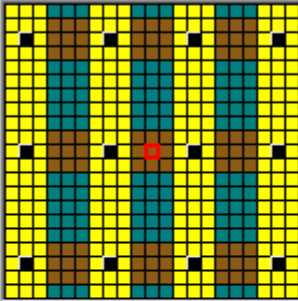
Navigation toolbar with icons for selection, zoom, and simulation control.

Number: 1/2 Name: Waiting Current (10, 20)

Color palette with various color swatches.

Number: 1/2 Name: Current 

 (21, 3)



Size ? ✕

Pixels Length units

Width: Width: m

Height: Height: m

Scaling factor:

Plate

ICON

The screenshot shows a software window titled ".MUs.Plate" with a menu bar containing "Navigate", "View", "Tools", and "Help". The main area is divided into several sections:

- Name:** A text input field containing "Plate".
- Label:** An empty text input field.
- Conveying direction:** A dropdown menu set to "0 (forward)".
- Attributes:** A tabbed section with four tabs: "Attributes", "Graphics", "Product Statistics", and "User-defined Attributes".

Under the "Attributes" tab, the following parameters are visible:

MU length:	0.8	m	Booking point (length):	0.5	[0..1]
MU width:	0.8	m	Booking point (width):	0.5	[0..1]
MU height:	1	m	Booking point (height):	0	[0..1]
Destination:	...				

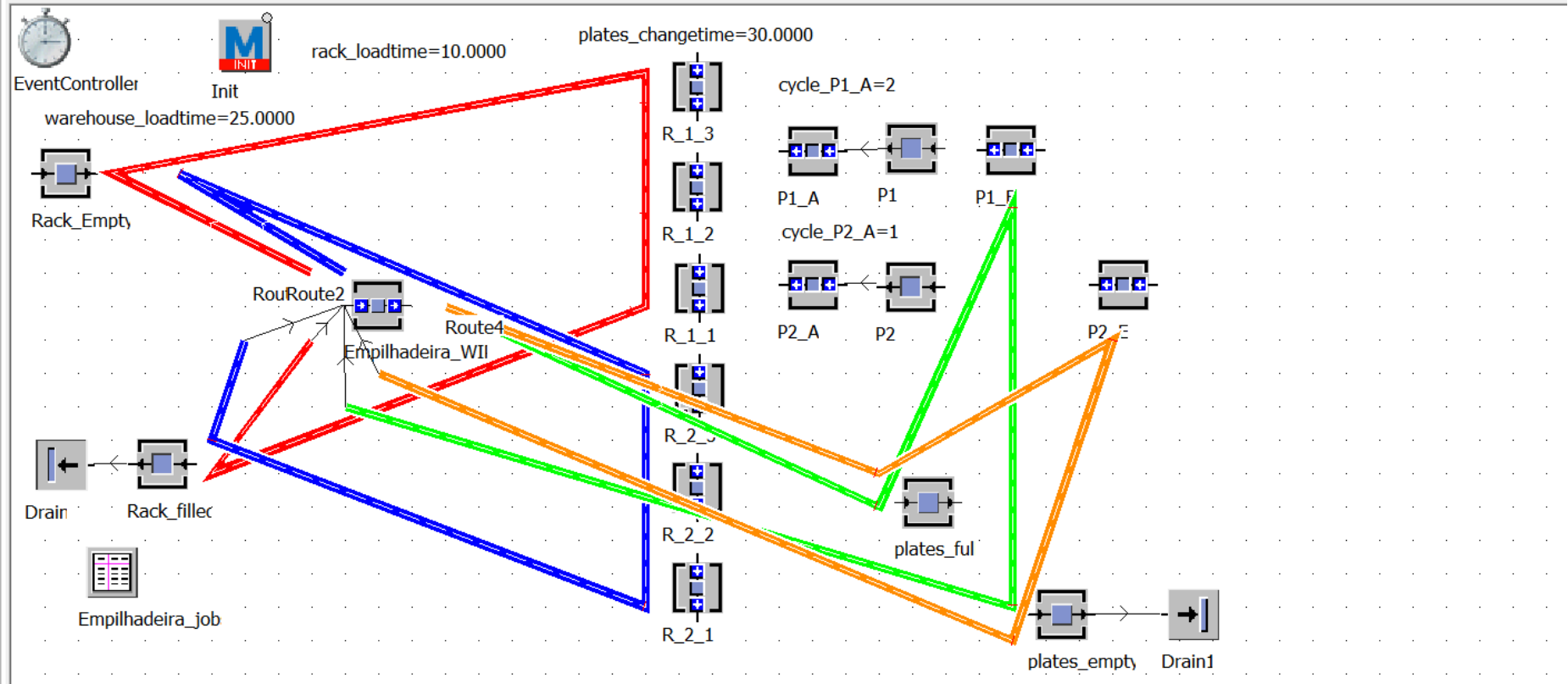
File Home Debugger Window General Icons Vector Graphics

Open Event Controller MU's Animation Open Location Navigate Paste Edit Select All Rename Delete MU's Icons Display Panel 3D Properties Controls Observers User-defined Attributes Statistics Report Structure Inheritance Context Help Manage Class Library

Class Library

- Basis (106/1000)
- MaterialFlow
- Fluids
- Resources
- InformationFlow
- Method
- Variable
- TableFile
- CardFile
- StackFile
- QueueFile
- TimeSequence
- Trigger
- Generator
- AttributeExplorer
- FileLink
- FileInterface
- XMLInterface
- Information_Flow
- INIT
- Empilhadeira_jobs
- UserInterface
- MU's
 - Entity
 - Container
 - Transporter
 - MU's
 - pallet
 - Empilhadeira
 - Rack
 - Plate
- Tools
- Models
 - Frame
- ApplicationObjects
- KanbanObjects
- Machines3D

Material Flow Fluids Resources Information Flow User Interface Mobile_Units Statistical Tools Tools Tools: Kanban Machines 3D



File Home Debugger Window General Icons Vector Graphics

Open Event Controller

MUs Icons Animation

Open Location Open Origin Open Class Open 2D/3D Navigate

Paste Copy Delete Edit

Select All Rename Delete MUs

Icons Display Panel

3D Properties

Controls Observers User-defined

Attributes Statistics Methods Report Objects

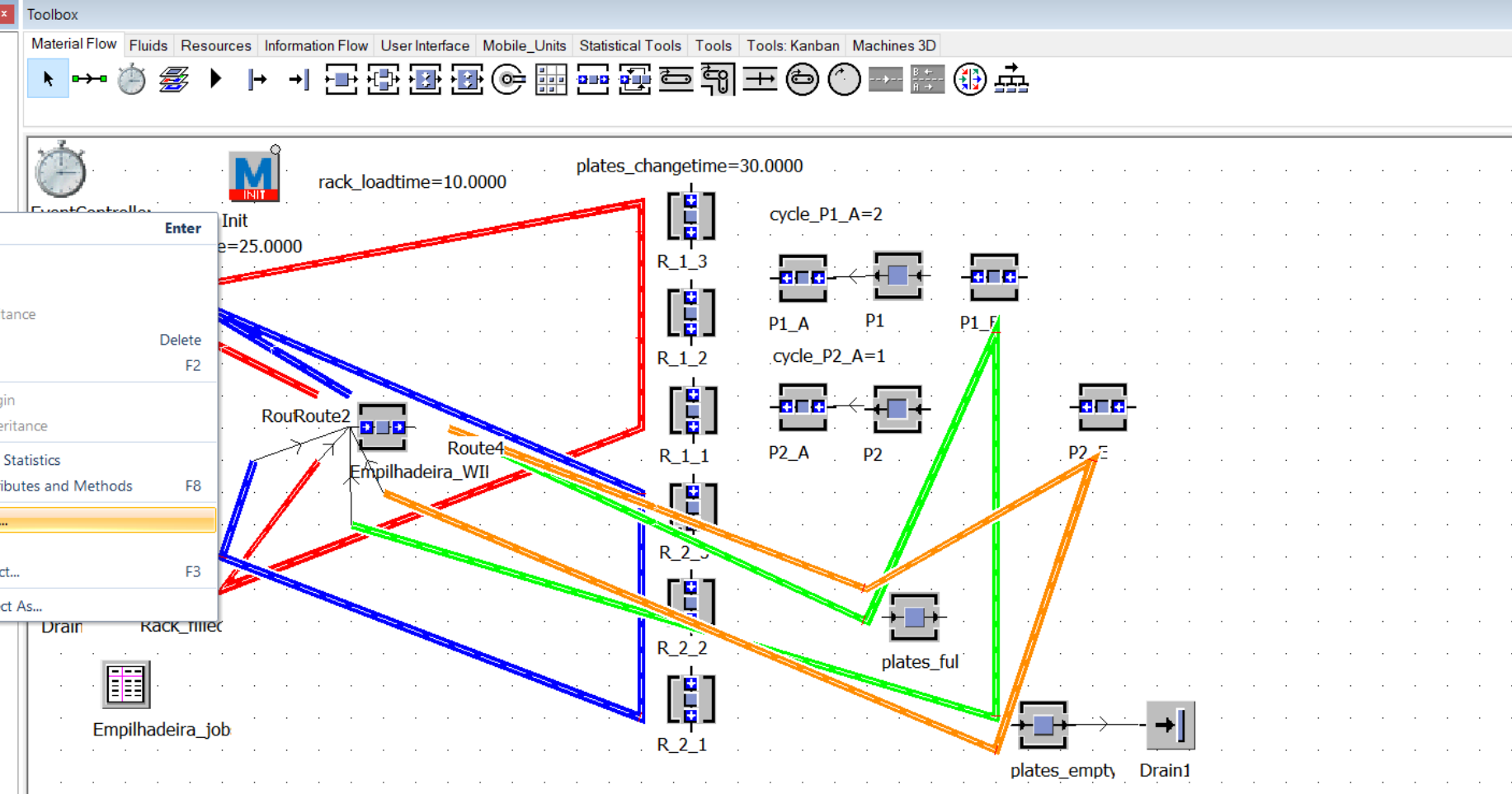
Structure Inheritance Context Help

Manage Class Library Model

Class Library

- Basis (106/1000)
- MaterialFlow
- Fluids
- Resources
- InformationFlow
 - Method
 - Variable
 - TableFile
 - CardFile
- UserInterface
- Mobile_Units
- Statistical Tools
- Tools
- Tools: Kanban
- Machines 3D

Material Flow Fluids Resources Information Flow User Interface Mobile_Units Statistical Tools Tools Tools: Kanban Machines 3D






Open Enter

- Duplicate
- Derive
- Cut Inheritance
- Delete Delete F2
- Rename F2
- Show Origin
- Show Inheritance
- Show MU Statistics
- Show Attributes and Methods F8
- Edit Icons...
- Print...
- Find Object... F3
- Save Object As...


.MUs.Plate ? X



Navigate View Tools Help



Name: 


Label:  Conveying direction: 


Attributes Graphics Product Statistics User-defined Attributes


Vector graphics active 

Color:  

Border color:  

Border width: 


Show direction arrow 



Show state 

OK Cancel Apply


.MUs.Plate ? X



Navigate View Tools Help



Name: 


Label:  Conveying direction: 


Attributes Graphics Product Statistics User-defined Attributes


Vector graphics active 

Color:  

Border color:  

Border width: 

Show direction arrow 

Show state 

OK Cancel Apply

- Method
- Variable
- TableFile
- CardFile
- StackFile
- QueueFile
- TimeSequence
- Trigger
- Generator
- AttributeExplorer
- FileLink
- FileInterface
- XMLInterface
- Information_Flow
- INIT
- Empilhadeira_jobs
- Folder: UserInterface
- Folder: MUs
 - Entity
 - Container
 - Transporter
 - MUs
 - pallet
 - Empilhadeira
 - Rack
 - Plate
- Folder: Tools
- Folder: Models
 - Frame
- Folder: ApplicationObjects
 - KanbanObjects
- Machines3D

Number: 0/2 Name: Current

< >

File Home Debugger Window **Edit** Animation General

New Import Export Size Transparent Apply Changes Overview Inherit Zoom In Zoom Out Drawing Color Pick Color Freehand Line Polyline Ellipse Rectangle Filled Rectangle Fill Area Copy/Paste Area Paste Area Replace Color Reference Point

File Settings Apply Go To Inheritance Zoom Actions

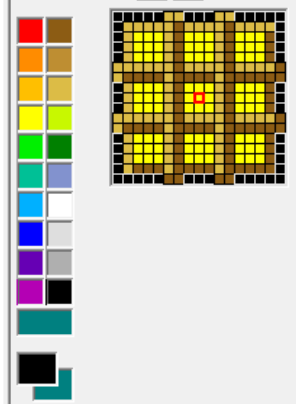
Class Library **Set Icon Size (Ctrl+I)**
Set the size of the icon.


Basis (106/10) Fluids Resources Information Flow User Interface Mobile_Units Statistical Tools Tools Tools: Kanban Machines 3D

- MaterialFlow
- Fluids
- Resources
- InformationFlow
 - Method
 - Variable
 - TableFile
 - CardFile
 - StackFile
 - QueueFile
 - TimeSequence
 - Trigger
 - Generator
 - AttributeExplorer
 - FileLink
 - FileInterface
 - XMLInterface
 - Information_Flow
 - INIT
 - Empilhadeira_jobs
- UserInterface
- MUs
 - Entity
 - Container
 - Transporter
 - MUs
 - pallet
 - Empilhadeira
 - Rack
 - Plate
- Tools
- Models
 - Frame
- ApplicationObjects
 - KanbanObjects
 - Machines3D


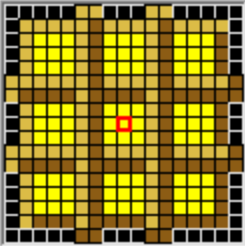
Navigation icons: mouse cursor, play, stop, step, zoom, and other controls.

Number: 1/2 Name: Waiting Current (4, 13)



Number: 1/2 Name: Current 

(4, 13)



Size ? X

Pixels Length units

Width: Width: m

Height: Height: m

Scaling factor:



Forklift

PONTO DE REFERÊNCIA

Icon | Empilhadeira_5.spp - Tecnomatix Plant Simulation 12

File Home Debugger Window Edit Animation General

New Import Export Size Transparent Apply Changes Overview Inherit Zoom In Zoom Out Drawing Color Pick Color Freehand Line Polyline Ellipse Rectangle Filled Rectangle Fill Area Copy/Paste Area Paste Area Replace Color Reference Point

Class Library

- Basis (106/1000)
 - MaterialFlow
 - Fluids
 - Resources
 - InformationFlow
 - Method
 - Variable
 - TableFile
 - CardFile
 - StackFile
 - QueueFile
 - TimeSequence
 - Trigger
 - Generator
 - AttributeExplorer
 - FileLink
 - FileInterface
 - XMLInterface
 - Information_Flow
 - INIT
 - Empilhadeira_jobs
 - UserInterface
 - MUs
 - Entity
 - Container
 - Transporter
 - MUs
 - pallet
 - Empilhadeira
 - Rack
 - Plate
 - Tools
 - Models
 - Frame
 - ApplicationObjects
 - KanbanObjects
 - Machines3D

Toolbox

Material Flow Fluids Resources Information Flow User Interface Mobile_Units Statistical Tools Tools Tools: Kanban Machines 3D

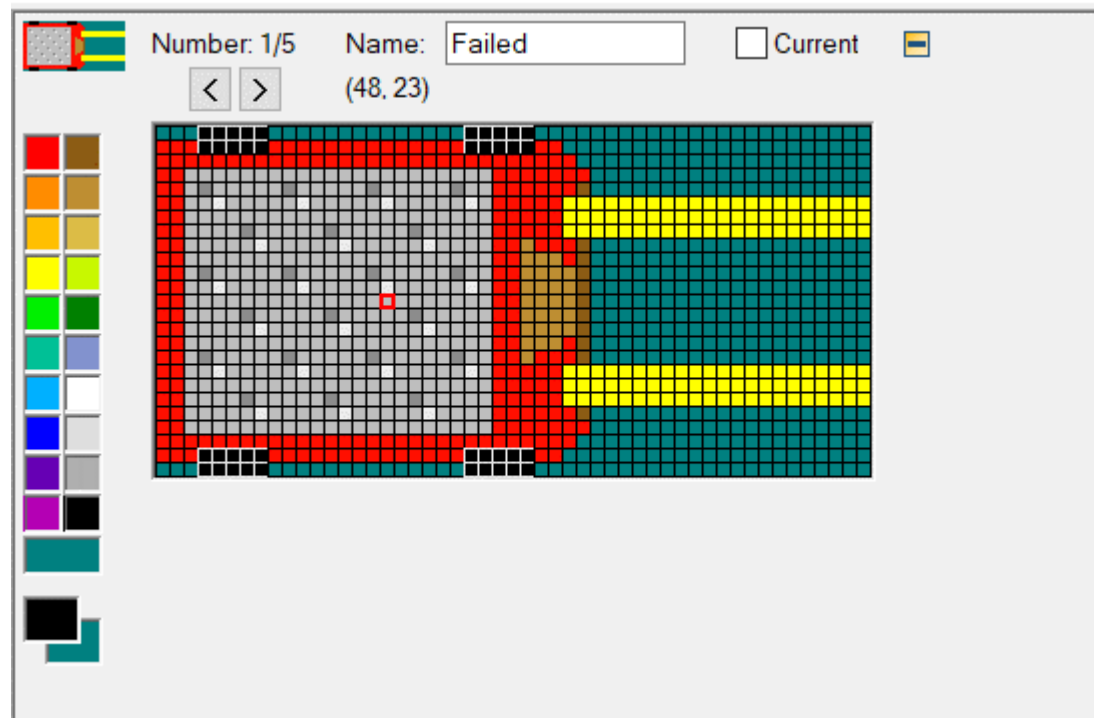
Number: 0/5 Name: Operational Current

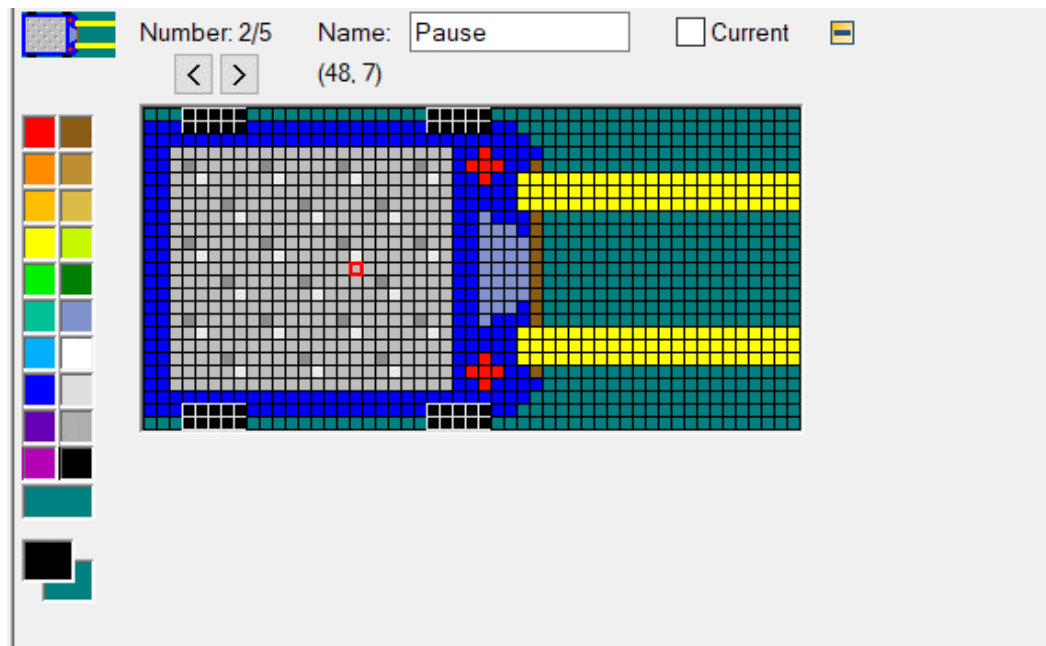
CLICK no ponto (vermelho) após selecionar a opção *Reference Point*. Arrastar com o mouse, ponto esquerdo pressionado, para o ponto requisitado


Number: 0/5 Name: Current

< > (42, 23)

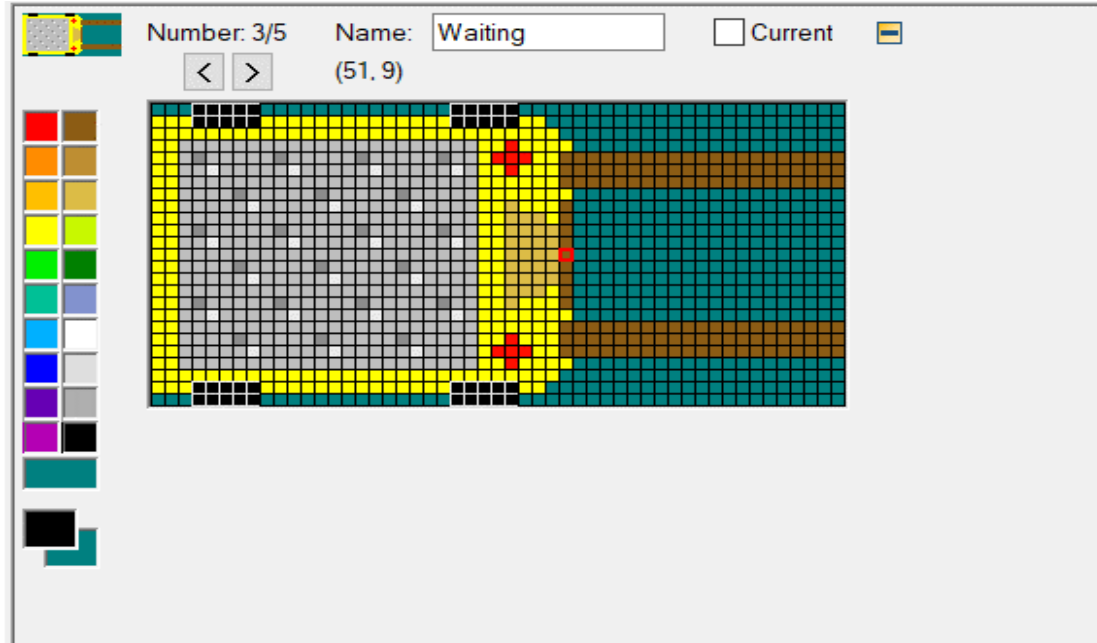
The image shows a software interface for a grid-based simulation. At the top, there is a header bar with a small icon of a grid, the text "Number: 0/5", a text input field containing "Operational", a checked checkbox labeled "Current", and a small blue icon. Below the header, there are navigation arrows "<" and ">" and the coordinates "(42, 23)". The main area is a large grid. The grid is mostly grey, with a thick orange border around a central grey area. To the right of the orange border is a teal area. There are several black rectangular blocks on the grid. A red crosshair is positioned at the coordinates (42, 23). On the left side of the grid, there is a vertical color palette with 15 color swatches: red, brown, orange, tan, yellow, light green, green, cyan, blue, light blue, purple, magenta, black, teal, and dark teal. At the bottom left of the grid, there are two small black and teal shapes.






Number: 3/5 Name: Current 

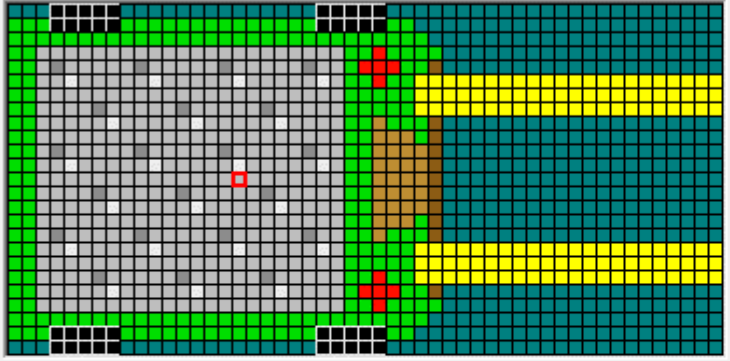
 (51, 9)



The image shows a software interface for a 2D grid-based simulation. At the top, there is a header area with a small icon of a robot on the left. To its right, the text "Number: 3/5" is displayed. Further right is a text input field containing the name "Waiting". To the right of the name field is a checkbox labeled "Current", which is currently unchecked. A small blue dropdown arrow icon is to the right of the checkbox. Below the header, there are two navigation buttons: a left-pointing chevron and a right-pointing chevron. To the right of these buttons, the coordinates "(51, 9)" are shown. The main area of the window is a large grid. The grid contains a yellow robot with two red eyes, positioned on a grey floor. To the right of the robot is a blue wall. The background of the grid is a mix of grey and white pixels, suggesting a floor or a path. On the left side of the window, there is a vertical color palette with 18 color swatches. The colors include red, orange, yellow, green, cyan, blue, purple, magenta, black, and teal. The entire window has a light grey background.

Number: 4/5 Name: tractor Current 

< > (36, 21)



The image shows a screenshot of a grid-based map editor. At the top, there is a header with a small icon of a tractor, the text "Number: 4/5", a text input field containing "tractor", a checkbox labeled "Current", and a small dropdown arrow. Below the header are two navigation buttons, "<" and ">", and the coordinates "(36, 21)". The main area is a 20x20 grid. The grid is divided into several colored regions: a grey area on the left, a green area on the right, a brown area in the center, and a yellow path on the right. A red square is located at the center of the grid, at coordinates (36, 21). On the left side of the grid, there is a color palette with 16 color swatches. At the bottom left of the grid, there is a toolbar with a few icons.



Forklift

POSIÇÃO *PALLET* GARFO EMPILHADEIRA

PONTO DE ANIMAÇÃO

0 – 3

ITENS DA ANIMAÇÃO

Icon | Empilhadeira_5.spp - Tecnomatix Plant Simulation 12

File Home Debugger Window Edit Animation General

Overview Zoom In Zoom Out Point Line Polyline Move Delete All Link Animation Events Animation Numbers Inherit Apply Changes

Go To Zoom Edit Settings Options Inheritance Apply

Class Library

- Basis (106/1000)
 - MaterialFlow
 - Fluids
 - Resources
 - InformationFlow
 - Method
 - Variable
 - TableFile
 - CardFile
 - StackFile
 - QueueFile
 - TimeSequence
 - Trigger
 - Generator
 - AttributeExplorer
 - FileLink
 - FileInterface
 - XMLInterface
 - Information_Flow
 - INIT
 - Empilhadeira_jobs
 - UserInterface
 - MUs
 - Entity
 - Container

Toolbox

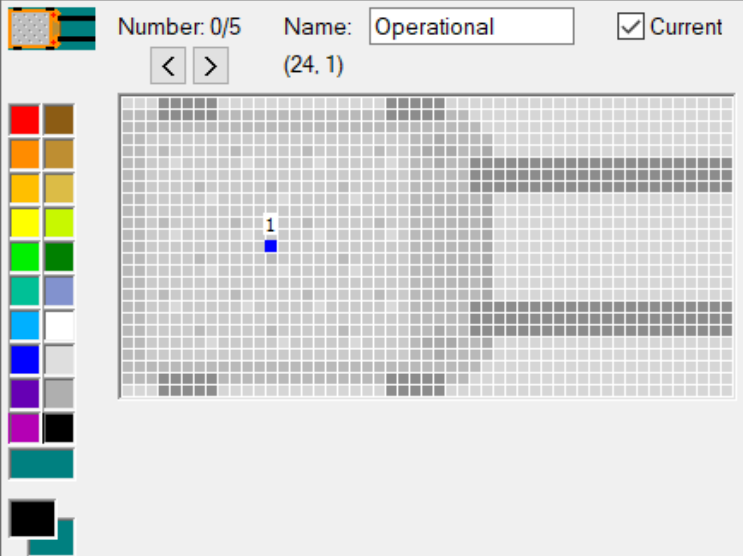
Material Flow Fluids

Move Animation Point

Hold down the left mouse button to move an animation point or animation line.

Number: 0/5 Name: Operational Current

(24, 1)



Dá um *click* no ponto azul e arrasta na posição desejada

File Home Debugger Window Edit Animation General

Overview Zoom In Zoom Out Point Line Polyline Move Delete All Link Animation Events Animation Numbers Inherit Apply Changes

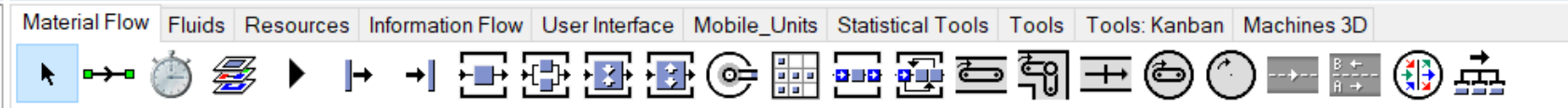
Go To Zoom Edit Settings Options Inheritance Apply

Class Library

- Basis (106/1000)
 - MaterialFlow
 - Fluids
 - Resources
 - InformationFlow
 - Method
 - Variable
 - TableFile
 - CardFile
 - StackFile
 - QueueFile
 - TimeSequence
 - Trigger
 - Generator
 - AttributeExplorer
 - FileLink
 - FileInterface
 - XMLInterface
 - Information_Flow
 - INIT
 - Empilhadeira_jobs
 - UserInterface
 - MUs
 - Entity
 - Container
 - Transporter

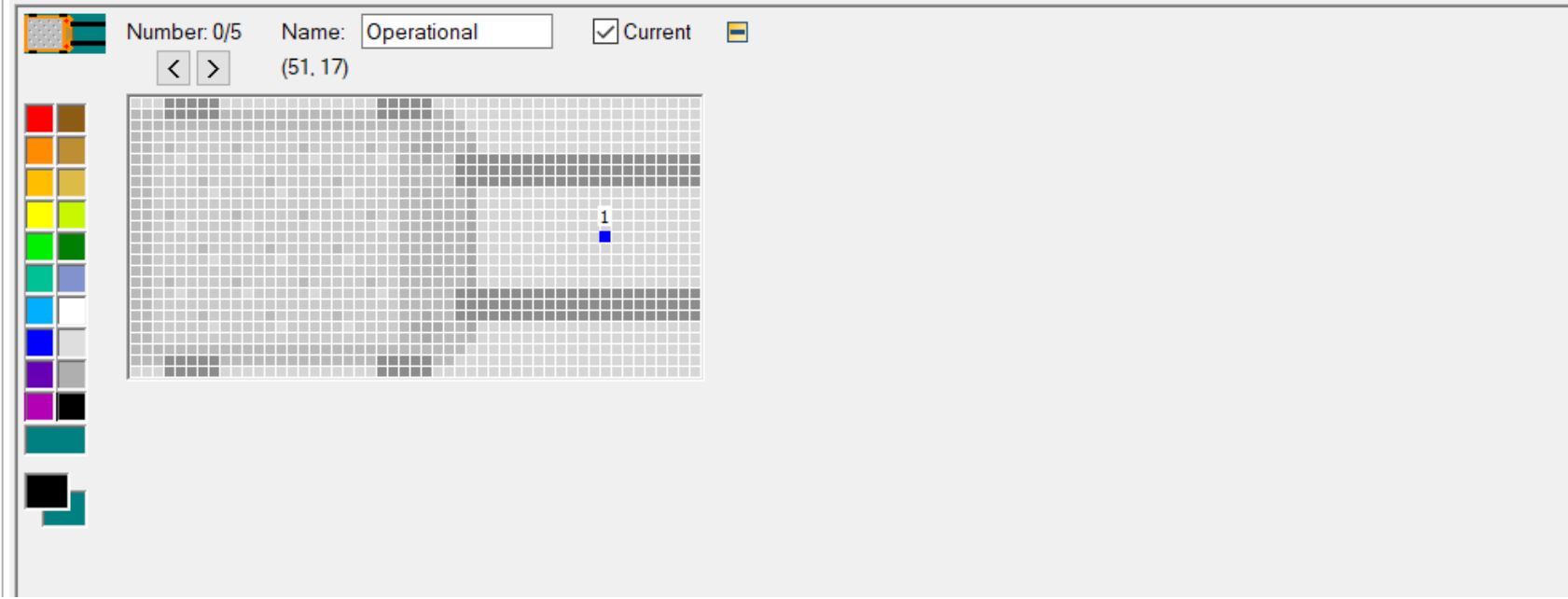
Toolbox

Material Flow Fluids Resources Information Flow User Interface Mobile_Units Statistical Tools Tools Tools: Kanban Machines 3D



Number: 0/5 Name: Operational Current

(51.17)



Icon | Empilhadeira_5.spp - Tecnomatix Plant Simulation 12

File Home Debugger Window Edit Animation General

Overview Zoom In Zoom Out Point Line Polyline Move Delete All Link Animation Events Animation Numbers Inherit Apply Changes

Go To Zoom Edit Settings Options Inheritance Apply

Class Library Toolbox

Material Flow Fluids Resources Information Flow User Interface Mobile_Units Statistical Tools Tools Tools: Kanban Machines 3D

Basis (106/1000)
MaterialFlow
Fluids
Resources
InformationFlow
Method
Variable
TableFile
CardFile
StackFile
QueueFile
TimeSequence
Trigger
Generator
AttributeExplorer
FileLink
FileInterface
XMLInterface
Information_Flow
INIT
Empilhadeira_jobs
UserInterface
MUs
Entity
Container
Transporter

Number: 0/5 Name: Operational Current (43, 13)

Animation point

Dá um *click* no ponto azul e muda o número da animação



Icon

Empilhadeira_5.spp - Tecnomatix Plant Simulation 12 - [.MUs.Empilhadeira]

File Home Debugger Window Edit Animation General

Overview Zoom In Zoom Out Point Line Polyline Move Delete All Link Animation Events Animation Numbers Inherit Apply Changes

Go To Zoom Edit Settings Options Inheritance Apply

Class Library

- Basis (106/1000)
- MaterialFlow
- Fluids
- Resources
- InformationFlow
 - Method
 - Variable
 - TableFile
 - CardFile
 - StackFile
 - QueueFile
 - TimeSequence
 - Trigger
 - Generator
 - AttributeExplorer
 - FileLink
 - FileInterface
 - XMLInterface
 - Information_Flow
 - INIT
 - Empilhadeira_jobs
- UserInterface
- MUs
 - Entity
 - Container
 - Transporter
 - MUs

Toolbox

Material Flow Fluids Resources Information Flow User Interface Mobile_Units Statistical Tools Tools Tools: Kanban Machines 3D



Number: 3/5 Name: Waiting Current

(50, 19)

File Home Debugger Window Edit Animation General

Overview Zoom In Zoom Out Point Line Polyline Move Delete All Link Animation Events Animation Numbers Inherit Apply Changes

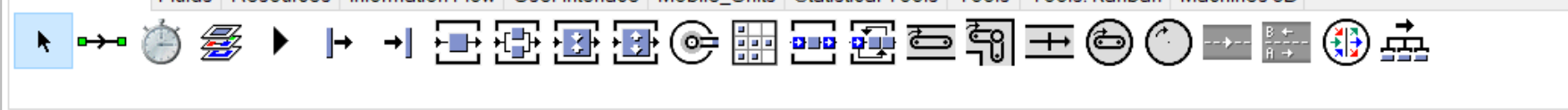
Go To Zoom Edit Settings Options Inheritance Apply

Class Library

- Basis (106/1000)
- MaterialFlow
- Fluids
- Resources
- InformationFlow
 - Method
 - Variable
 - TableFile
 - CardFile
 - StackFile
 - QueueFile
 - TimeSequence
 - Trigger
 - Generator
 - AttributeExplorer
 - FileLink
 - FileInterface
 - XMLInterface
 - Information_Flow
 - INIT
 - Empilhadeira_jobs
- UserInterface
- MUs
 - Entity
 - Container
 - Transporter
 - MUs
 - pallet

Toolbox

Material Flow Fluids Resources Information Flow User Interface Mobile_Units Statistical Tools Tools Tools: Kanban Machines 3D



Number: 3/5 Name: Waiting Current

(43, 13)



1 - 2 - 4

OS DEMAIS ITENS DA ANIMAÇÃO

File Home Debugger Window Edit Animation General

Overview Zoom In Zoom Out Point Line Polyline Move Delete All Link Animation Events Animation Numbers Inherit Apply Changes


Go To Zoom Edit Settings Options Inheritance Apply

Class Library

- Basis (106/1000)
 - MaterialFlow
 - Fluids
 - Resources
 - InformationFlow
 - Method
 - Variable
 - TableFile
 - CardFile
 - StackFile
 - QueueFile
 - TimeSequence
 - Trigger
 - Generator
 - AttributeExplorer
 - FileLink
 - FileInterface
 - XMLInterface
 - Information_Flow
 - INIT
 - Empilhadeira_jobs
 - UserInterface
 - MUs
 - Entity
 - Container
 - Transporter

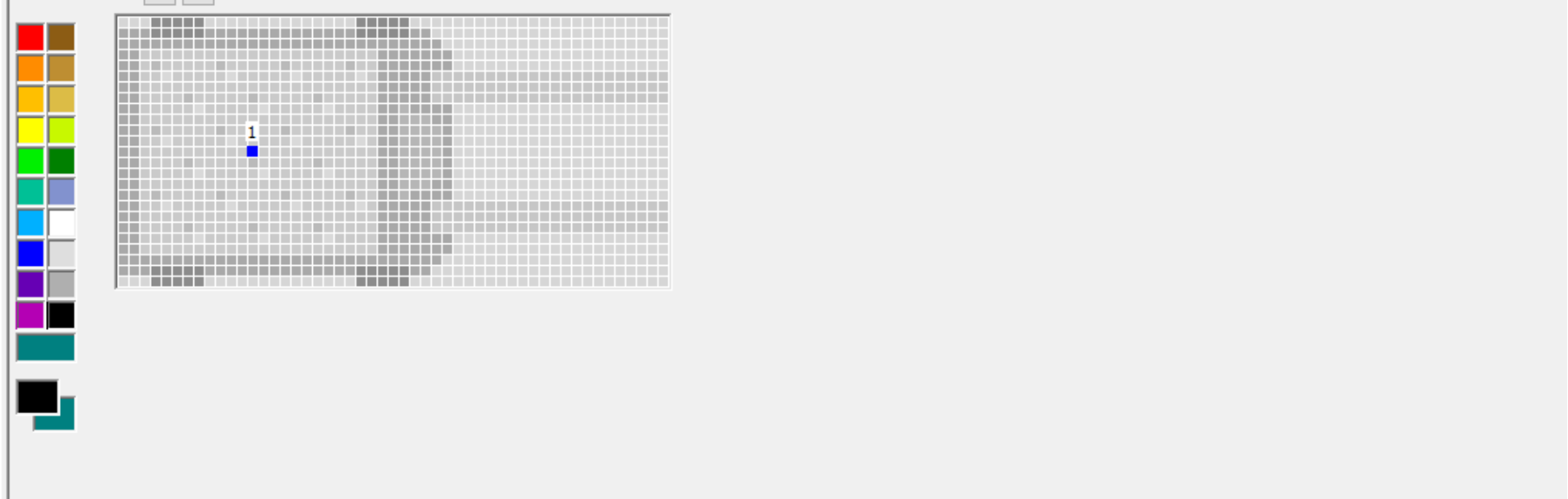
Toolbox

Material Flow Fluids Resources Information Flow User Interface Mobile_Units Statistical Tools Tools Tools: Kanban Machines 3D



Number: 1/5 Name: Failed Current

< > (46. 20)





Icon

Empilhadeira_5.spp - Tecnomatix Plant Simulation 12 - [MUs.Empilhadeira]

File Home Debugger Window Edit Animation General

Overview Zoom In Zoom Out Point Line Polyline Move Delete All Link Animation Events Animation Numbers Inherit Apply Changes

Go To Zoom Edit Settings Options Inheritance Apply

Class Library

- Basis (106/1000)
- MaterialFlow
- Fluids
- Resources
- InformationFlow
 - Method
 - Variable
 - TableFile
 - CardFile
 - StackFile
 - QueueFile
 - TimeSequence
 - Trigger
 - Generator
 - AttributeExplorer
 - FileLink
 - FileInterface
 - XMLInterface
 - Information_Flow
 - INIT
 - Empilhadeira_jobs
- UserInterface
- MUs
 - Entity
 - Container
 - Transporter
 - MI Is

Toolbox

Material Flow Fluids Resources Information Flow User Interface Mobile_Units Statistical Tools Tools Tools: Kanban Machines 3D

Number: 2/5 Name: Pause Current

< > (40.25)



Icon

File Home Debugger Window Edit Animation General

Overview Zoom In Zoom Out Point Line Polyline Move Delete All Link Animation Events Animation Numbers Inherit Apply Changes

Go To Zoom Edit Settings Options Inheritance Apply

Class Library

- Basis (106/1000)
 - MaterialFlow
 - Fluids
 - Resources
 - InformationFlow
 - Method
 - Variable
 - TableFile
 - CardFile
 - StackFile
 - QueueFile
 - TimeSequence
 - Trigger
 - Generator
 - AttributeExplorer
 - FileLink
 - FileInterface
 - XMLInterface
 - Information_Flow
 - INIT
 - Empilhadeira_jobs
 - UserInterface
 - MUs
 - Entity
 - Container
 - Transporter

Toolbox

Material Flow Fluids Resources Information Flow User Interface Mobile_Units Statistical Tools Tools Tools: Kanban Machines 3D

Number: 4/5 Name: tractor Current (46, 12)

Color palette



MÉTODO *INIT*

Método INIT

is

```
    pallet:object;
```

do

```
    -- create rack and pallets
```

```
    .MUs.Rack.create(rack_empty);
```

```
    .MUs.Rack.create(R_1_1);
```

```
.MUs.Rack.create(R_1_2);
```

```
.MUs.Rack.create(R_1_3);
```

```
.MUs.Rack.create(R_2_1);
```

```
.MUs.Rack.create(R_2_2);
```

```
.MUs.Rack.create(R_2_3);
```

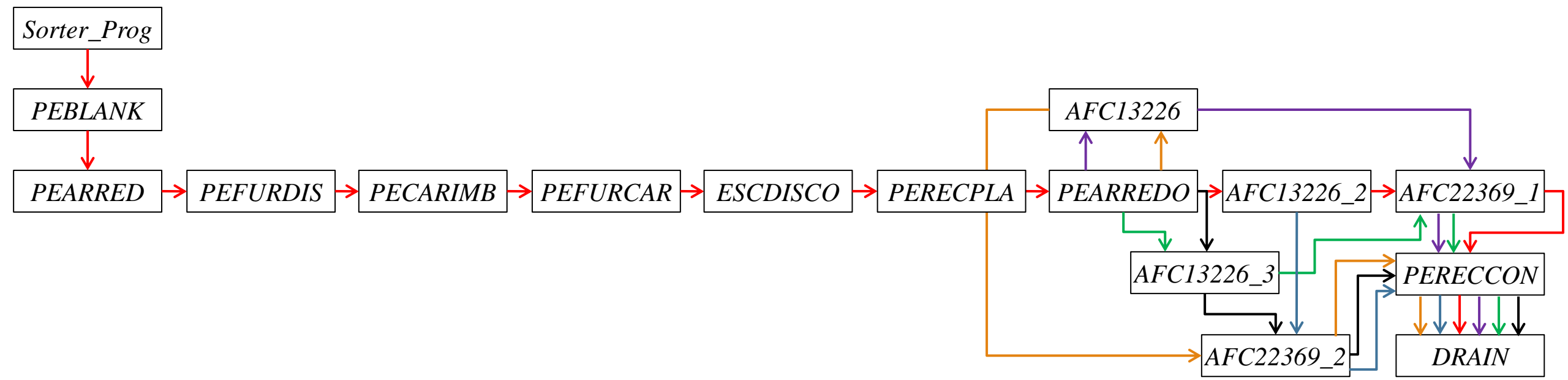
Método INIT

```
pallet:=.MUs.Pallet.create(Plates_full);  
  
while not pallet.full loop  
    .MUs.Plate.create(pallet);  
  
end;  
  
--insert Empilhadeira (Empilhadeira)  
  
.MUs.Empilhadeira.create(Empilhadeira_WIP);  
  
--create the first two jobs for the empilhadeira (Empilhadeira)  
  
empilhadeira_jobs[1,1]:="Route3";  
empilhadeira_jobs[1,2]:="Route4";  
  
end;
```



Projeto _ Bruno _ Natália _ Raíne

ROTAS



- 1ª Rota
- 2ª Rota
- 3ª Rota
- 4ª Rota
- 5ª Rota
- 6ª Rota

Sorter_Prog



PEBLANK



PEARRED



PEFURDIS



PECARIMB



PEFURCAR



ESCDISCO



PERECPLA



PEARREDO



AFC13226_2



AFC22369_1



PERECCON



DRAIN

→ 1ª Rota

Sorter_Prog



PEBLANK



PEARRED



PEFURDIS



PECARIMB



PEFURCAR



ESCDISCO



PERECPLA



PEARREDO

AFC13226



AFC22369_1



PERECCON



DRAIN

 **1ª Rota**
 **2ª Rota**

Sorter_Prog



PEBLANK



PEARRED

PEFURDIS

PECARIMB

PEFURCAR

ESCDISCO

PERECPLA

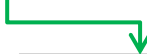
PEARREDO

AFC13226_3

AFC22369_1

PERECCON

DRAIN



 **1ª Rota**

 **3ª Rota**

Sorter_Prog



PEBLANK



PEARRED

PEFURDIS

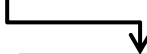
PECARIMB

PEFURCAR

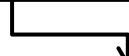
ESCDISCO

PERECPLA

PEARREDO



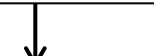
AFC13226_3



AFC22369_2



PERECCON



DRAIN

→ **1ª Rota**

→ **4ª Rota**

Sorter_Prog

PEBLANK

PEARRED

PEFURDIS

PECARIMB

PEFURCAR

ESCDISCO

PERECPLA

PEARREDO

AFC13226

AFC22369_2

PERECCON

DRAIN

→ **1ª Rota**

→ **5ª Rota**

Sorter_Prog



PEBLANK



PEARRED

PEFURDIS

PECARIMB

PEFURCAR

ESCDISCO

PERECPLA

PEARREDO

AFC13226_2



AFC22369_2

PERECCON



DRAIN

→ 1ª Rota

→ 6ª Rota

TEMPOS DE DESLOCAMENTO

TEMPO DE DESLOCAMENTO

EMPILHADEIRA

<u>PEBLANK</u>	→	PEARRED	=	00:00:30
PEARRED	→	PEFURDIS	=	00:01:00
<u>PECARIMB</u>	→	PEFURCAR	=	00:01:30
PEFURCAR	→	ESCDISCO	=	00:00:45
<u>PERECPLA</u>	→	PEARREDO	=	00:01:30
PEARREDO	→	AFC13226_3	=	00:00:30
<u>PEARREDO</u>	→	AFC13226_2	=	00:00:30
PEARREDO	→	AFC13226	=	00:00:30
<u>AFC13226_3</u>	→	AFC22369_1	=	00:00:30
AFC13226_3	→	AFC22369_2	=	00:00:30

CRANE

Crane

Tecnomatix+Plant+Simulation.

The Plant Simulation Multi-Portal Crane Object. Page 352

Model Handling Robots Using Transporter and Track. Page 380

Example: Multi portal crane

https://community.plm.automation.siemens.com/siemensplm/attachments/siemensplm/tecnomatix-forum%40tkb/123/2/PlantSimulation_PortalCrane_v13.mp4

<https://community.plm.automation.siemens.com/t5/Tecnomatix-Knowledge-Base/Using-a-Portal-Crane-Tecnomatix-Plant-Simulation/ta-p/286266>

Colisão ⇒

<https://community.plm.automation.siemens.com/t5/Plant-Simulation-Forum/Portal-Crane-collision-control/td-p/37344>

https://www.symeo.com/en/industries/cranes/index.html?gclid=EAIaIQobChMIrtzaxbq42QIVFYCRCh3BywNtEAAYAiAAEgIRX_D_BwE

Example: Crane

No *Plant Simulation* pode-se criar *cranes* com uma combinação de *tracks* (trilhas) e *transporters*. O *software* fornece dois objetos para a modelagem de *cranes*. O *StorageCrane* é preliminarmente usado para a modelagem de estoque e reabastecimento em uma área *warehouse*, enquanto o *multi-portal crane* é um conceito flexível para a modelagem do processo de transporte que são manipulados por pontes rolantes (*portal cranes*).

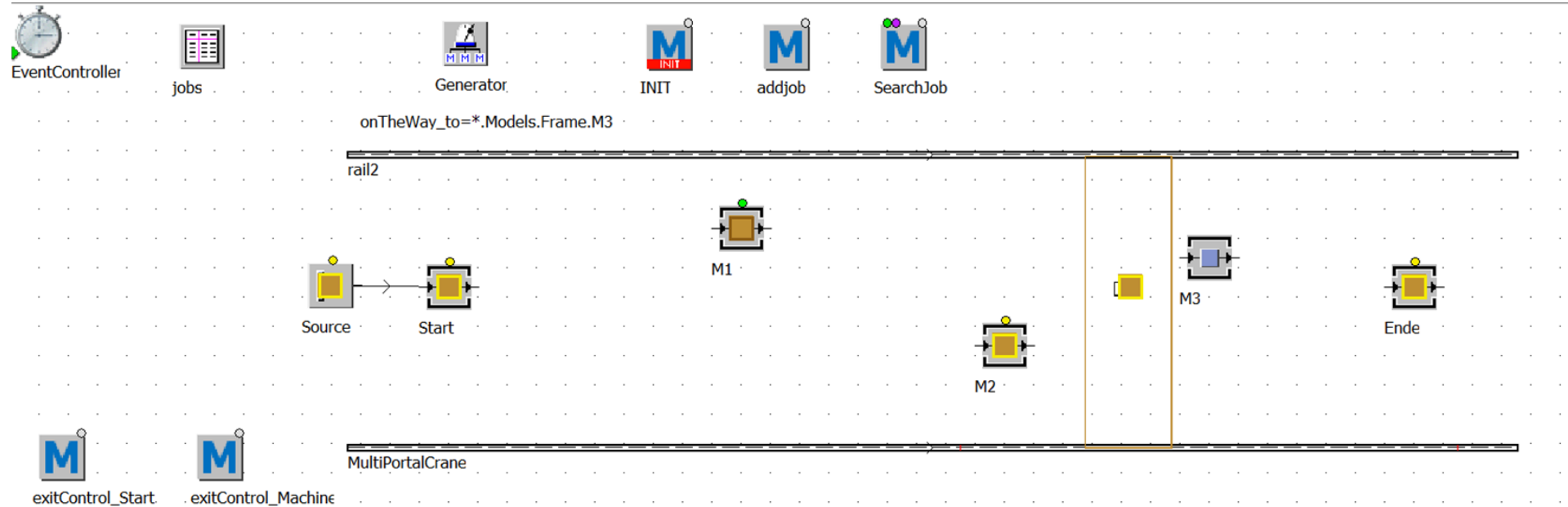
O objeto *multi-portal crane* é is baseado em uma combinação de *tracks* e *transporters*. Fornece um grupo de atributos e métodos para criar o funcionamento do *portal cranes*. Ele pode mover alguns portais sobre a trilha de uma *crane*. O *multi-portal crane* tem um grupo de atributos e métodos *SimTalk* (Tabela 1).

Example: Crane (Tabela 1)
Multi-portal crane attributes and methods

Métodos & Atributos	Descrição
<code><crane>.getPortals(tableFile list)</code>	Writes references to the portals in a table and the table is automatically formatted
<code><portal>.endSequence</code>	Sets the state of the portal crane to "idle" and should be called at the end of a load sequence
<code><portal>.moveHook(real position)</code>	Moves the hook of the crane to the given position
<code><portal>.moveTo(real X, real Y, real Z)</code>	Moves the portal to the specified position; if you pass -1 for Z, the hook is not moved
<code><portal>.moveToObject(object destination)</code>	Moves the portal to the passed object
<code><portal>.moveToPosition(integer posX, integer posY)</code>	Moves the portal to the passed position (pixel position in the network)
<code><portal>.state</code>	State of the portal (waiting, driving, idle)
<code><portal>.hook</code>	Returns a reference to the hook of the crane

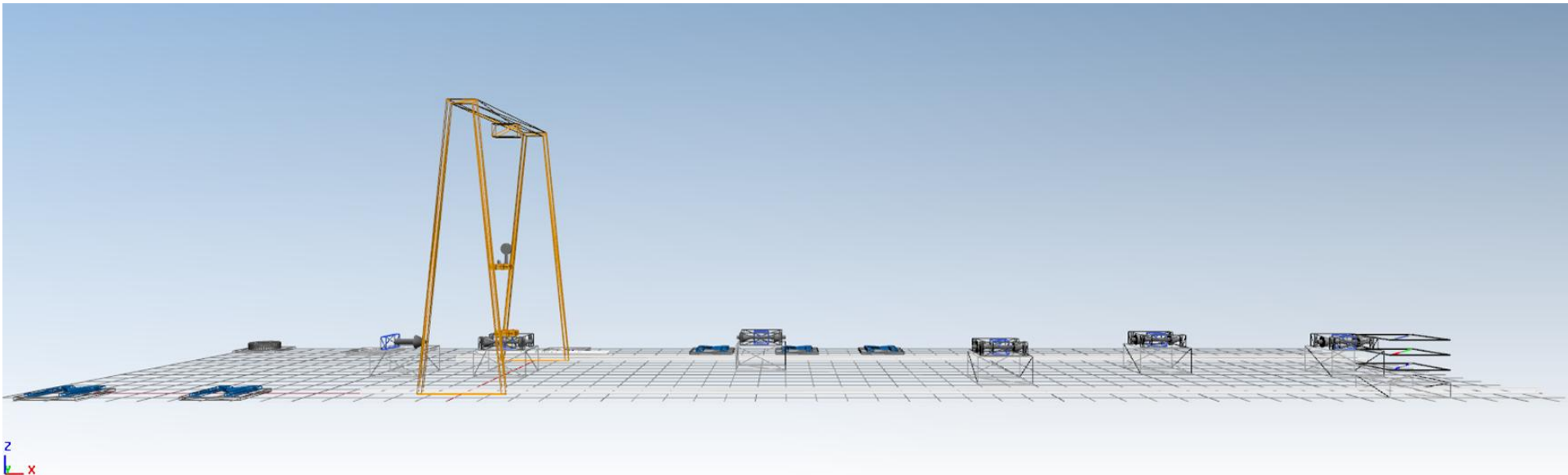
Example: Crane

Três máquinas são carregadas e descarregadas através do portal *crane*. Após o reposicionamento no *start*, as peças são processadas em M1, M2 ou M3. Após a usinagem, as peças são movidas para a estação “*Ende*”. Criar um *frame* igual o das Figuras 1 e 2.



Example: Crane

Dê um *Double-click* no objeto *multi-portal crane* para configurá-lo, sendo: *length of the crane track* (comprimento da trilha da *crane*) (L) = 40 metros; largura da trilha da *crane* (w) = 10 metros; número de portais = 1; comprimento do portal = três metros; largura do portal = 10 metros; altura do portal = 10 metros; *overlang* = 0 metros; velocidade = 1.3 metros/segundo; altura de elevação do *Trolley* = 10 metros; velocidade do *Trolley* = 1 metro/segundo; velocidade do gancho (*hook*) = 0.25 metros/segundo. A área de suprimentos (*source*) opera com um intervalo de dois minutos; a máquina M1 tem um tempo de processamento de dez minutos; a máquina M2 tem um tempo de processamento de doze minutos; a máquina M3 tem um tempo de processamento de sete minutos. A Tabela dos Jobs deve ser formatada de acordo com a Figura 3.



File Home Debugger Window List

Import Export Print Find Replace Go To Insert Row Insert Column Sort Ascending Sort Descending Formula Column Index Row Index Format Inherit Format Inherit Contents Inherit Comment Recompute Formulas Comment Data Type Highlight Empty Cells Open Object

File Find Edit Format Inheritance View Tools

Class Library Toolbox

- Basis (456/1000)
 - MaterialFlow
 - Connector
 - EventController
 - Frame
 - Interface
 - Source
 - Drain
 - SingleProc
 - ParallelProc
 - Assembly
 - DismantleStation
 - PickAndPlace
 - Store
 - PlaceBuffer
 - Buffer
 - Sorter
 - Line
 - AngularConverter
 - Converter
 - Turntable
 - Turnplate
 - Track
 - TwoLaneTrack
 - FlowControl
 - Cycle
 - Material_Flow
 - Start
 - M1
 - M2
 - M3
 - Ende
 - Fluids
 - Resources
 - InformationFlow
 - Method
 - Variable
 - TableFile

Finite State Machine Logistic VSM_Objects VSM_Tools VSM_Connections Machines 3D Genetic Algorithms Comau Robots 3D Truck 3D

Material Flow Fluids Resources Information Flow User Interface Mobile Units Statistical Tools Tools Tools: Kanban Cranes Materialflow Controls Rework SKIDS JustinTime Evaluation Random Number AssemblyLine

	object 1	object 2
string	from	to
1		
2		
3		
4		
5		
6		
7		
8		
9		
10		
11		
12		
13		
14		
15		
16		
17		
18		
19		
20		
21		
22		
23		
..		

Example: Crane

O método de inicialização “*INIT*” deleta no início da simulação o conteúdo das tarefas da tabela e define o *multi-portal crane* como "inativo" da primeira vez.

is

do

jobs.delete;



multiPortalCrane.cont.endSequence;

end;

O método addJob leva o objeto de origem e o objeto de destino como parâmetros e os insere em uma nova linha na tabela de trabalhos.

(source:object;destination:object)

is

do

jobs.writeRow(1,jobs.yDim+1,source,destination);

end;

Example: Crane



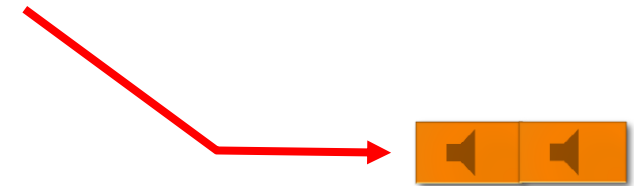
Carregar e descarregar usando o *PortalCrane*

Um transporte com o *PortalCrane* ocorre em várias etapas (*takes place in several steps*):

1. (Aguarde até que o estado do guindaste se torne "ocioso") *Wait until the crane state becomes "idle"*.
2. (Mova o portal vazio para a máquina) *Move the empty portal to the machine.*
3. (Abaixe o gancho do guindaste) *Lower the crane hook.*
4. (Capturar (mover) a peça através do gancho) *Hang (move) the part on the hook.*
5. (Puxe o gancho do guindastre) *Pull up the crane hook.*
6. (Mova o *crane* para a próxima posição) *Move the crane to the next position.*
7. (Abaixe o gancho com a peça) *Lower the hook with the part.*
8. (Mover e transferir a peça do gancho para a máquina) *Move the part from the hook to the machine.*
9. (Puxar o gancho) *Pull up the hook.*
10. (Ao chamar *endSequence*, o portal é liberado para o próximo trabalho) *By calling endSequence you release the portal for the next job.*

Example: Crane

Uma vez que há a possibilidade de outras solicitações serem requisitadas ao *PortalCrane*, as solicitações para a *crane* são armazenadas em uma tabela. A primeira solicitação de transporte ocorre (*takes place*) na saída do objeto *Start* (*exitControl_start*, *front*). O controle de saída (*exit control*) aguarda uma estação ser liberada e gera uma solicitação para a *crane* (*addjob*). A variável *onTheWay_to* é usada para evitar que mais de uma solicitação seja criada para um mesmo destino de transporte.



Example: Crane



.Models.Frame.Start ? X

Navigate View Tools Help

Name: Start Failed Entrance locked

Label: Planned Exit locked

Importer	Failure Importer	Energy	User-defined Attributes	
Times	Set-Up	Failures	Exit Strategy	Statistics
Entrance:	<input type="text"/>	<input type="checkbox"/>	<input type="checkbox"/> Before actions	<input type="checkbox"/>
Exit:	exitControl_Start <input type="text"/>	<input type="checkbox"/>	<input checked="" type="checkbox"/> Front <input type="checkbox"/> Rear	<input type="checkbox"/>
			<input type="checkbox"/> Exit control once	<input type="checkbox"/>
Set-up:	<input type="text"/>	<input type="checkbox"/>		
Pull:	<input type="text"/>	<input type="checkbox"/>		
Shift calendar:	<input type="text"/>	<input type="checkbox"/>		

OK Cancel Apply

is

```
target:=object;
```

do

```
--search empty machine and create job
```

```
waituntil (m1.empty and onTheWay_to /= m1) or
```

```
(m2.empty and onTheWay_to /= m2) or (m3.empty and onTheWay_to /= m3) prio 1;
```

```
if (m1.empty and onTheWay_to /= m1) then
```

```
    target:=m1;
```

```
elseif (m2.empty and onTheWay_to /= m2) then
```

```
    target:=m2;
```

```
elseif (m3.empty and onTheWay_to /= m3) then
```

```
    target:=m3;
```

```
end;
```

```
addJob(?,target);
```

```
onTheWay_to:=target;
```

end;

Example: Crane



Example: Crane



As máquinas M1, M2 e M3 tem o mesmo *exit control* (*ExitControl_Machine*). O *exit control* cria uma ordem de transferência da máquina para o *drain* (*Ende*).

is

do

```
    addJob(?,ende);
```

end;

O controle da *crane* em si ocorre no método (*itself takes place*) *searchJob*. O método *searchJob* é chamado a cada dez segundos pelo gerador. O método verifica se um trabalho deve ser executado, lê o início e o fim e controla o guindaste apropriadamente.

PARTE 1 DO MÉTODO

Example: Crane

is

```
start:object;
```

```
target:object;
```

```
portal:object;
```

do

```
portal:=multiPortalCrane.cont; -- the crane has to be finished and a job must exit
```

```
if portal.state="idle" and jobs.yDim>0 then --adress the cran and delete the job
```

```
    start:=jobs[1,1];
```

```
    target:=jobs[2,1];
```

```
    jobs.cutRow(1); --go to start
```

```
    portal.moveToObject(start);
```



PARTE 2 DO MÉTODO

Example: Crane

```
waituntil portal.state="waiting" prio 1; --move hook down
```

```
portal.moveHook(1.5);
```

```
waituntil portal.state="waiting" prio 1; --hook part
```

```
start.cont.move(portal.hook); --move hook up
```

```
portal.moveHook(9);
```

```
waituntil portal.state="waiting" prio 1; --go to target
```



PARTE 3 DO MÉTODO

Example: Crane

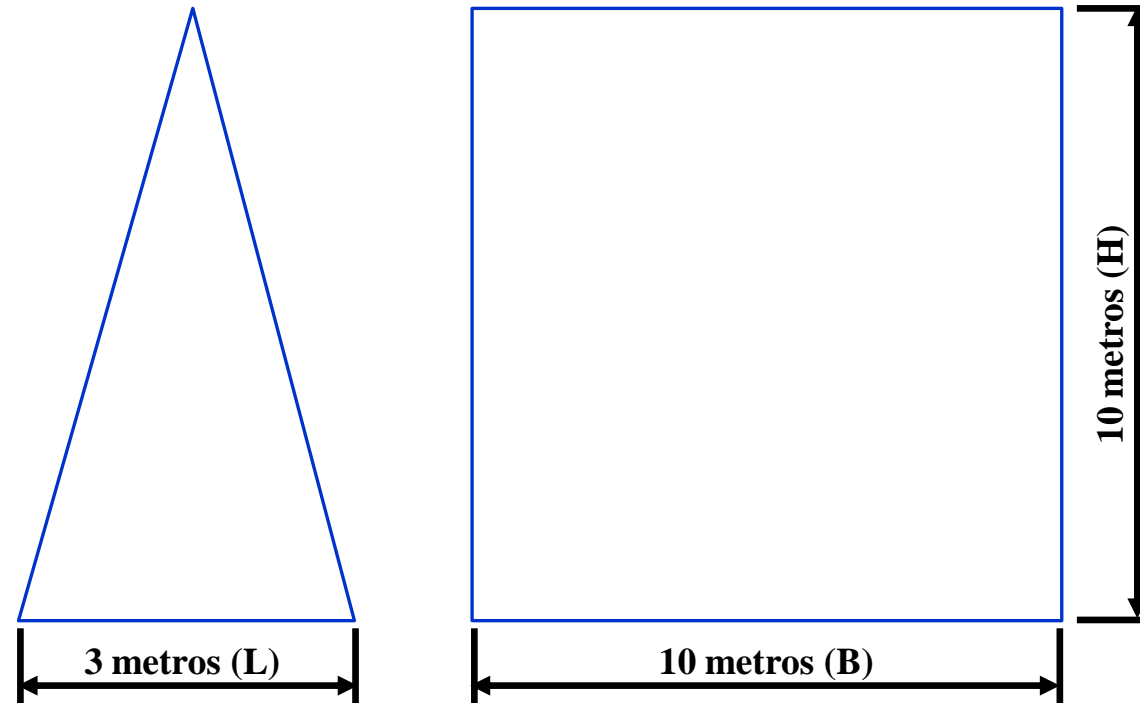
```
portal.moveToObject(target);  
    waituntil portal.state="waiting" prio 1; --move hook down  
portal.moveHook(1.5);  
    waituntil portal.state="waiting" prio 1; --unhook part  
portal.hook.cont.move(target); -- move hook up  
portal.moveHook(9);  
    waituntil portal.state="waiting" prio 1; -- finish job  
portal.endSequence;  
end;  
end;
```





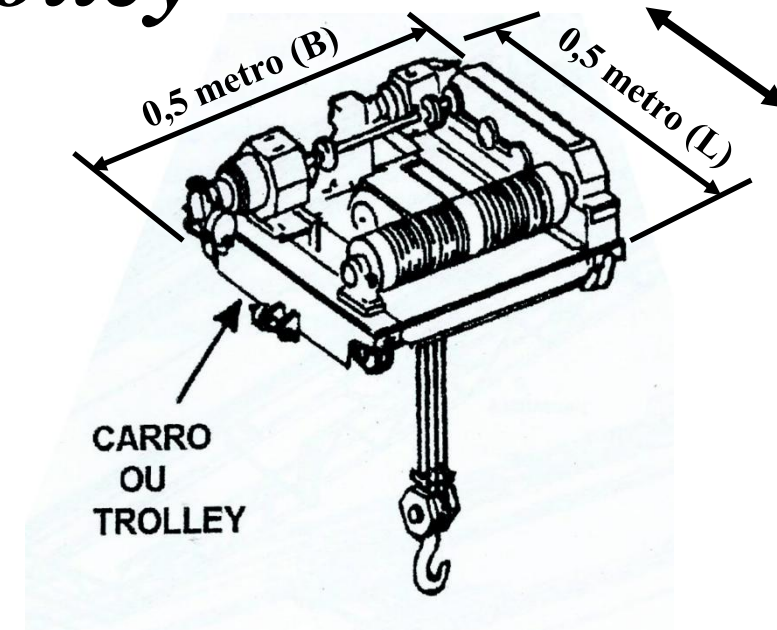
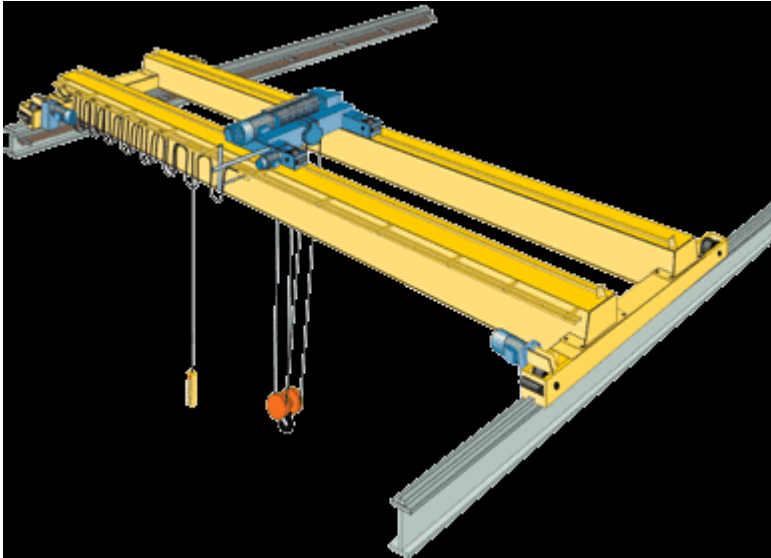
Descrição	Dimensão
<i>Length of Runway (L)</i>	40 metros
<i>Width of Runway (B)</i>	10 metros

Portal



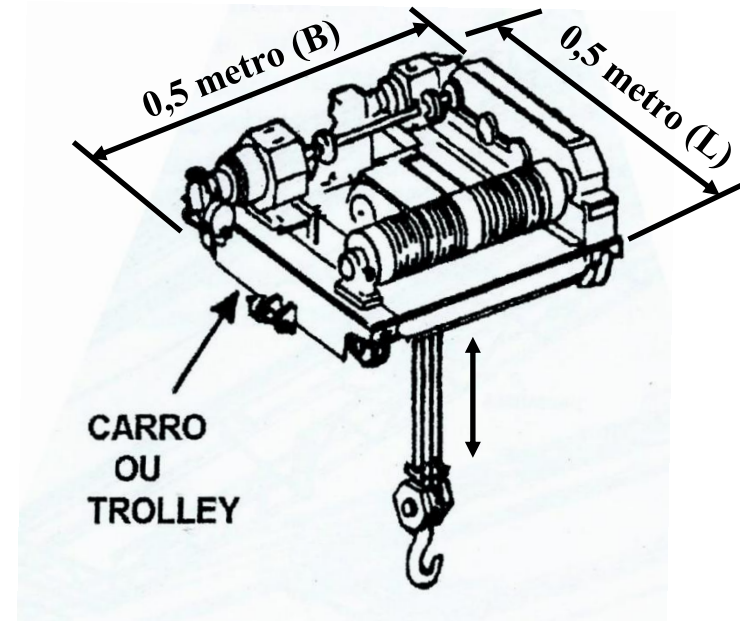
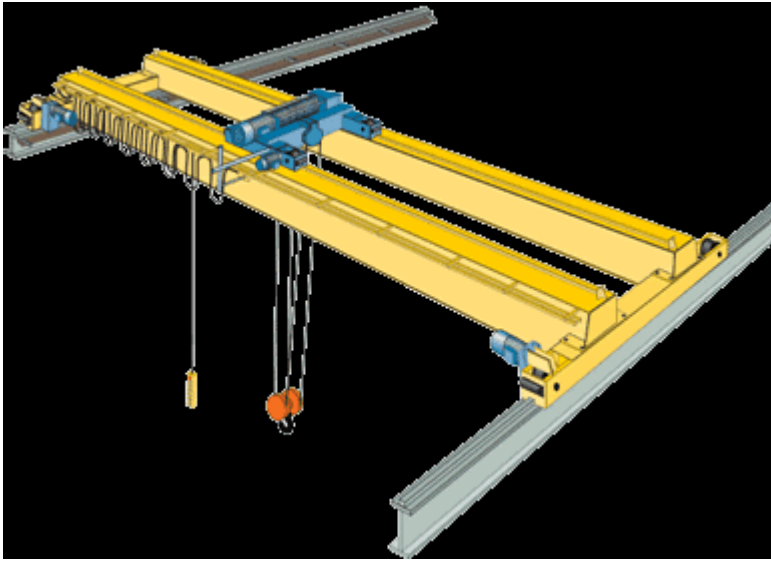
1 metro/segundo

Trolley – carro ou *Trolley*



Descrição	Dimensão
<i>Length</i>	0,5 metro
<i>Width</i>	1,0 metro
<i>Height</i>	0,5 metro
<i>Liftheight</i> (altura de elevação)	10 metros
<i>Speed</i>	1 metro / segundo

Hook – gancho/cabp



Descrição	Dimensão
<i>Height</i>	0,3 metros
<i>Speed</i>	0,25 metros / segundo

Plate Handing

Dimensão utilizada da Crane (SM17-SM18)
page 49

KC_shipyard_book_SmartBook-opti.pdf

Fabricante: KoneCranes (Lifting Business)

Smarter where it matters

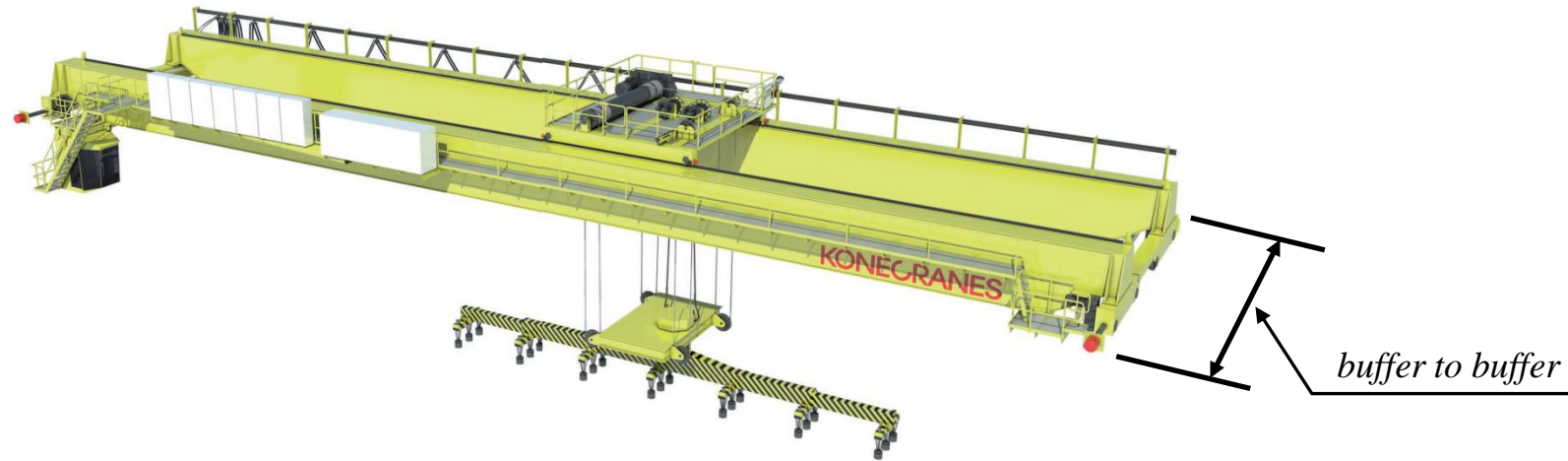
Offering for the shipbuilding industry

www.konecranes.com

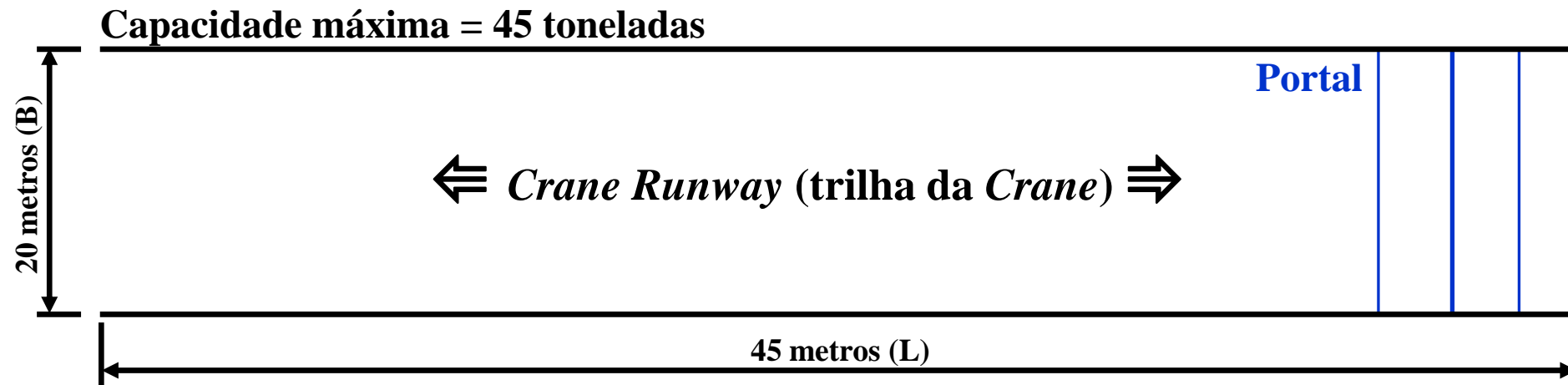


Plate handling

This crane can be equipped with a high-visibility cabin or radio remote control.



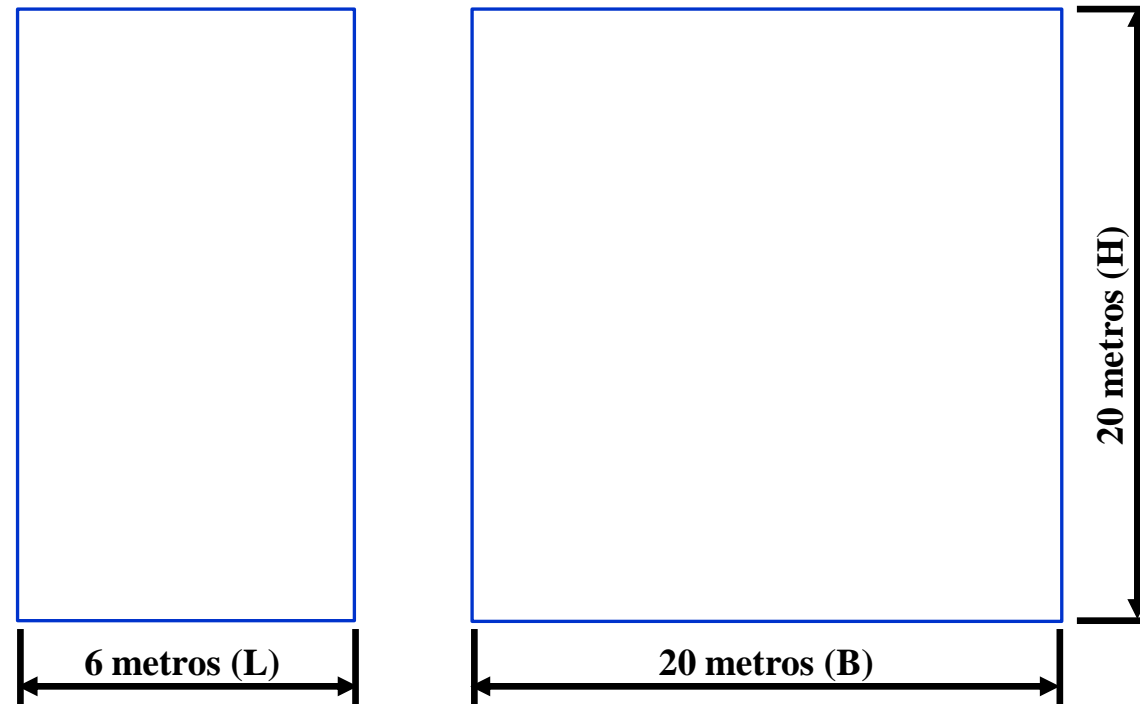
<i>Lifting capacity</i> (capacidade de elevação)	CXT100-CXT600	SM17-SM18	LV10-LV30
Capacidade máxima	11 – 16 toneladas	25 – 80 toneladas	10 – 30 toneladas (<i>under magnet</i>) (sobre o imã)
<i>Auxiliary hoist</i> (guincho auxiliar)	-----	-----	CXT
Principais Dimensões			
<i>Span</i> (alcance)	até 40 metros	até 45 metros	até 50 metros
<i>Lifting height</i> (levantamento de peso)	até 20 metros	até 20 metros	até 15 metros
<i>Buffer to buffer</i>	abaixo de 4 metros	abaixo de 6 metros	abaixo de 8 metros
Velocidades			
<i>Bridge travel speed</i> (velocidade de movimentação da ponte)	30–50 m/min	30–50 m/min	40–100 m/min
<i>Trolley traversing speed</i> (velocidade de deslocamento do Trolley)	15–25 m/min	20–40 m/min	20–50 m/min
<i>Slewing speed</i> (velocidade de giro)	-----	-----	0,50 r/min.
<i>Hoisting speed with nominal load</i> (velocidade de elevação com carga nominal)	4–10 m/min	4–10 m/min	5–12 m/min
Sistema Elétrico			
<i>Bridge power supply</i> (fonte de alimentação da fonte)	condutor	condutor	condutor
<i>Trolley power supply</i> (fonte de alimentação do trole)	<i>festoon</i>	<i>festoon</i>	<i>festoon</i>
<i>Drive and control system</i> (sistema de condução e controle)	<i>Konecranes</i> (AC)	<i>Konecranes</i> (AC)	<i>Konecranes</i> (AC)
Controle	radio	radio	Radio / cabine
Manutenção			
<i>Crane diagnostics</i>	<i>standart</i>	<i>standart</i>	<i>standart</i>
Remote diagnostics	<i>option</i>	<i>option</i>	<i>option</i>



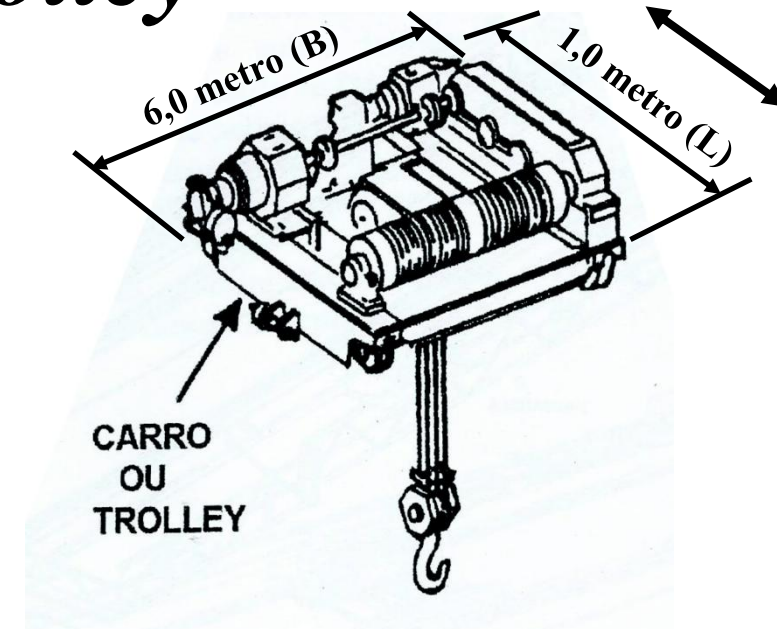
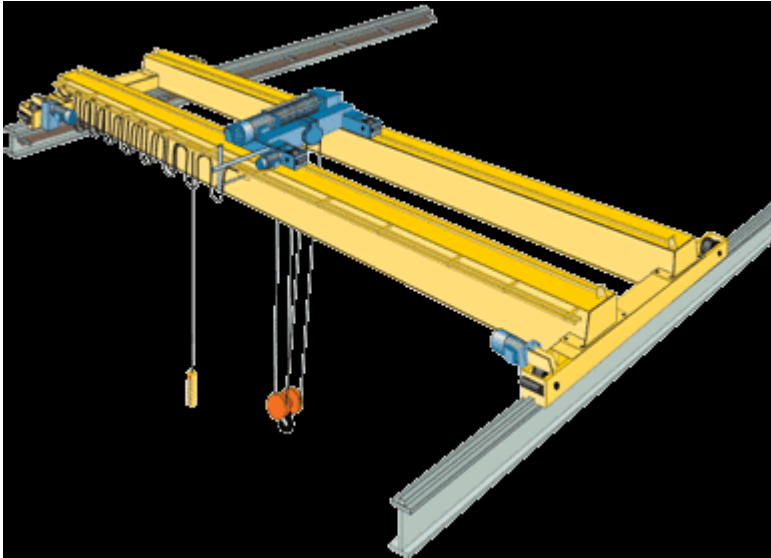
Descrição	Dimensão
<i>Length of Runway (L)</i>	45 metros
<i>Width of Runway (B)</i>	20 metros

Portal

Velocidade = 50 m/min. \approx 0.833 m/seg.

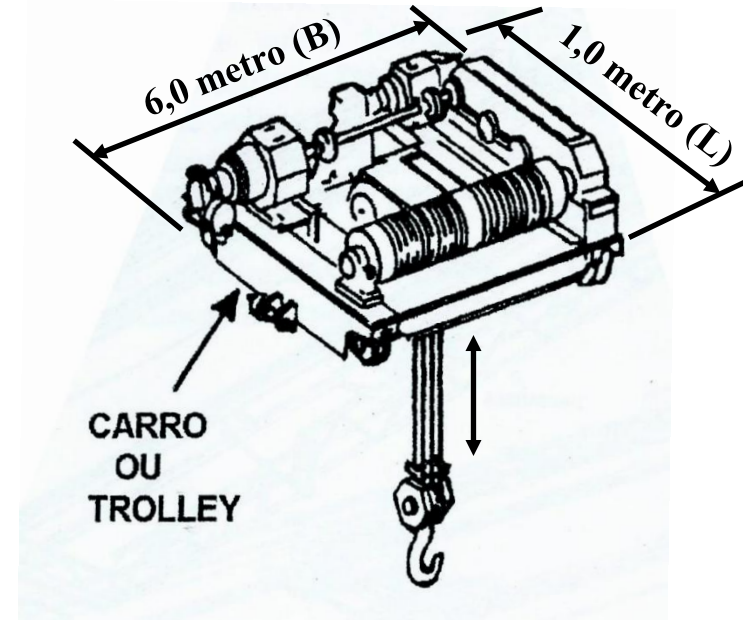
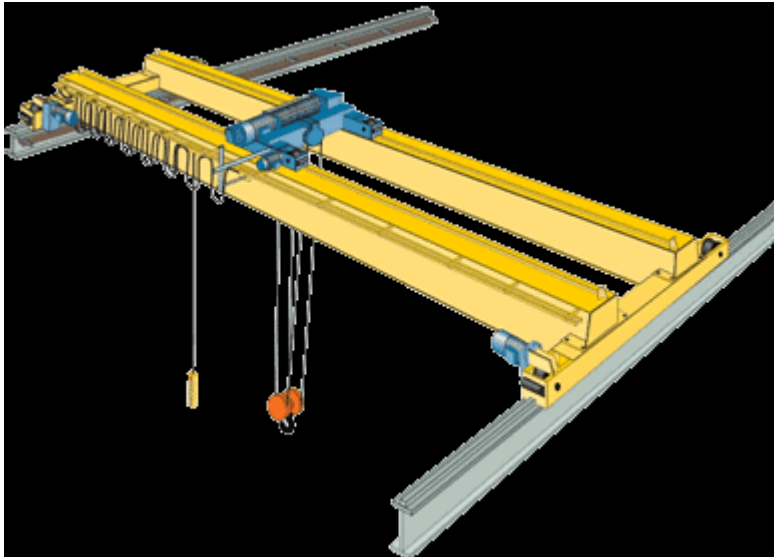


Trolly – carro ou *Trolley*



Descrição	Dimensão
<i>Length</i> (L)	1,0 metro
<i>Width</i> (W)	6,0 metro
<i>Height</i> (H)	1,0 metro
<i>Liftheight</i> (altura de elevação)	20 metros
<i>Speed</i>	0,67 metro / segundo

Hook – gancho/cabp



Descrição	Dimensão
<i>Height</i>	0,3 metros
<i>Speed</i>	0,25 metros / segundo

BLOCK HANDLING CRANE

Dimensão utilizada da Crane (SMT17-SMT20) page 51

KC_shipyard_book_SmartBook-opti.pdf

Fabricante: KoneCranes (Lifting Business)

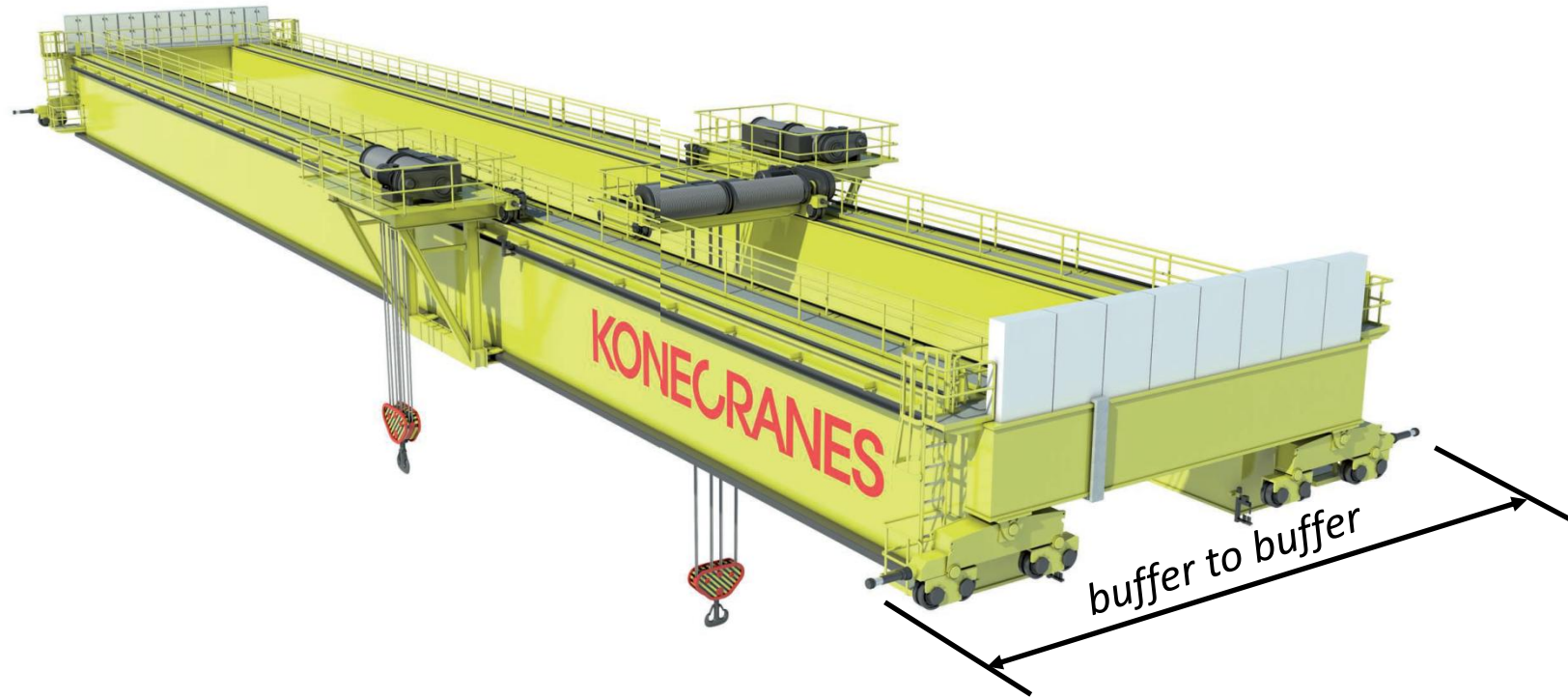
Smarter where it matters

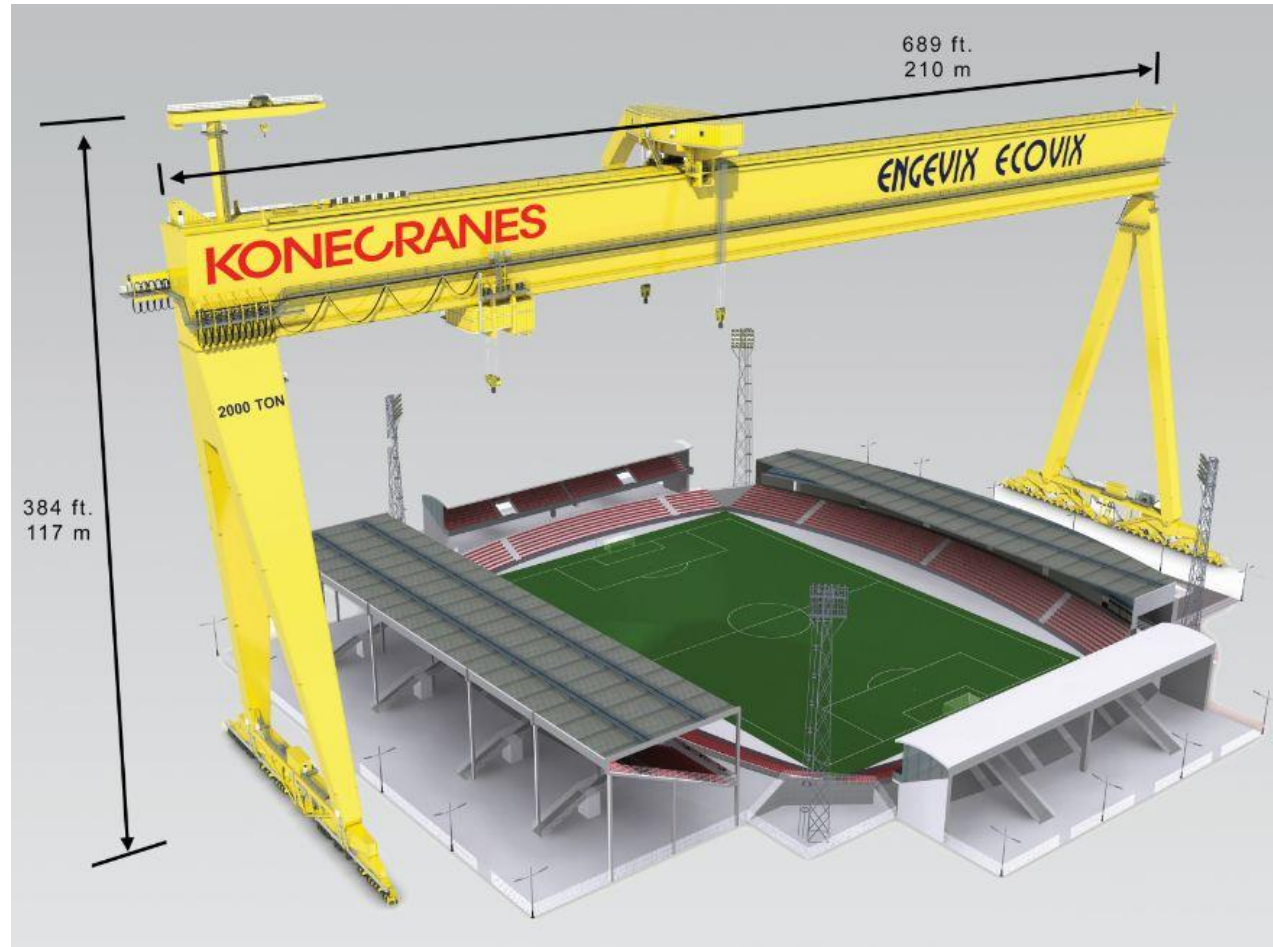
Offering for the shipbuilding industry

www.konecranes.com

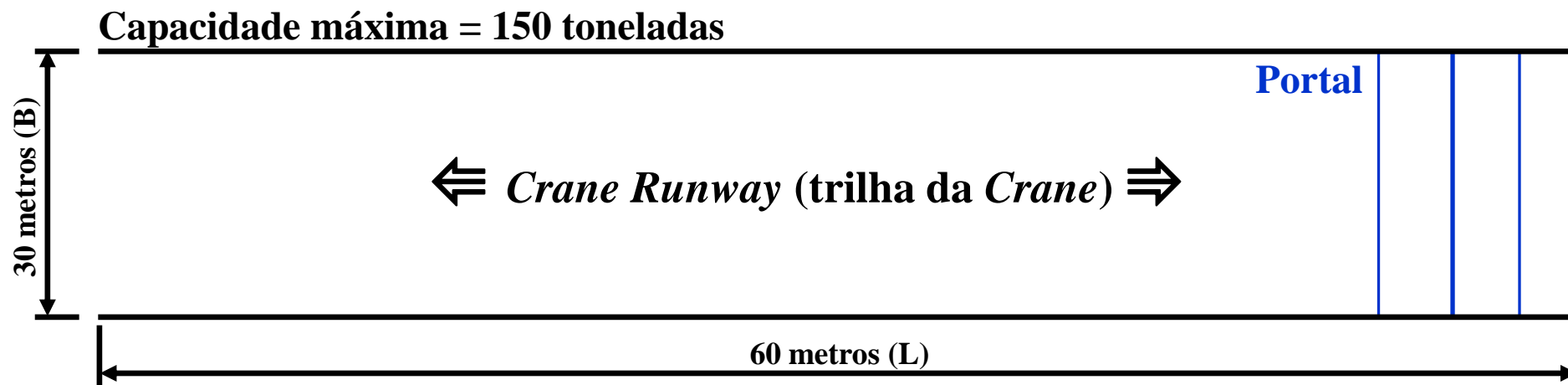
BLOCK HANDLING CRANE

This crane can be equipped with a high-visibility cabin or radio remote control.





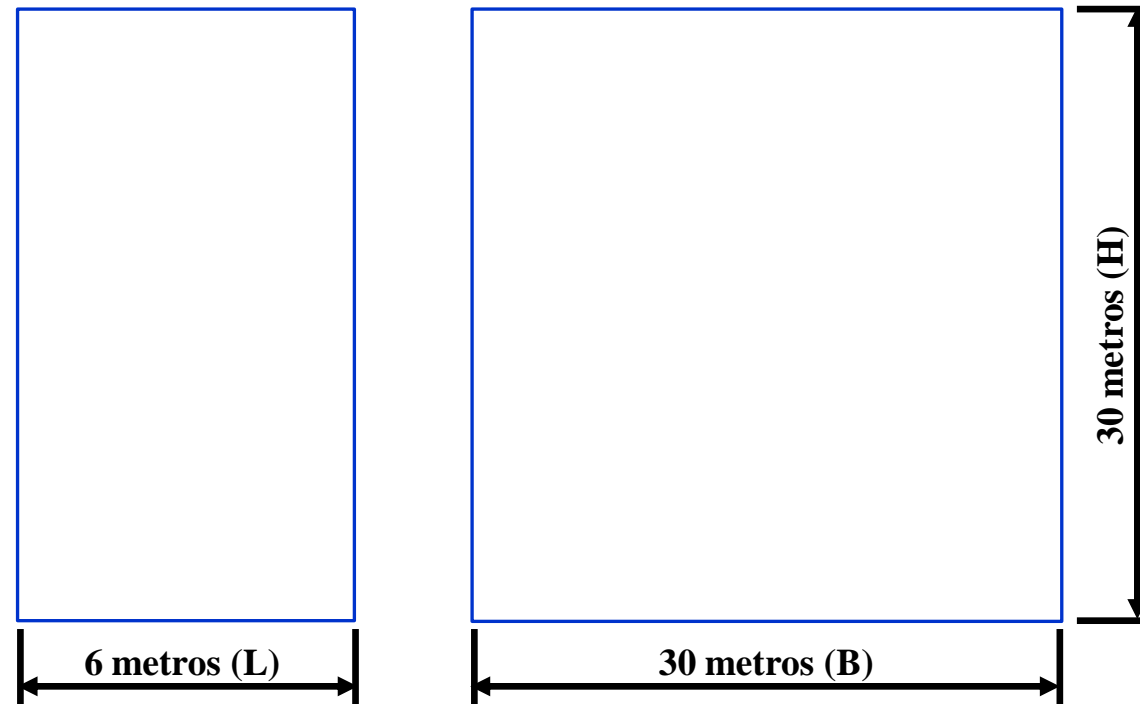
<i>Lifting capacity</i> (capacidade de elevação)	CXT100-CXT600	SM17-SM18	LV10-LV30
Capacidade máxima	1 – 16 toneladas	16 – 250 toneladas	50 – 350 toneladas
<i>Auxiliary hoist</i> (guincho auxiliar)	-----	CXT	CXT
Principais Dimensões			
<i>Span</i> (alcance)	até 110 metros	até 60 metros	até 80 metros
<i>Lifting height</i> (levantamento de peso)	até 20 metros	até 30 metros	até 40 metros
Velocidades			
<i>Bridge travel speed</i> (velocidade de movimentação da ponte)	30–50 m/min	30–60 m/min	30–50 m/min
<i>Trolley traversing speed</i> (velocidade de deslocamento do <i>Trolley</i>)	15–25 m/min	20–40 m/min	15–30 m/min
<i>Hoisting speed with nominal load</i> (velocidade de elevação com carga nominal)	4–10 m/min	3–10 m/min	3–10 m/min
Sistema Elétrico			
<i>Bridge power supply</i> (fonte de alimentação da fonte)	condutor	condutor	condutor
<i>Trolley power supply</i> (fonte de alimentação do trole)	<i>festoon</i>	<i>festoon</i>	<i>festoon</i>
<i>Drive and control system</i> (sistema de condução e controle)	<i>Konecranes</i> (AC)	<i>Konecranes</i> (AC)	<i>Konecranes</i> (AC)
Controle	radio	radio	Radio / cabine
Manutenção			
<i>Crane diagnostics</i>	<i>standart</i>	<i>standart</i>	<i>standart</i>
Remote diagnostics	<i>option</i>	<i>option</i>	<i>option</i>



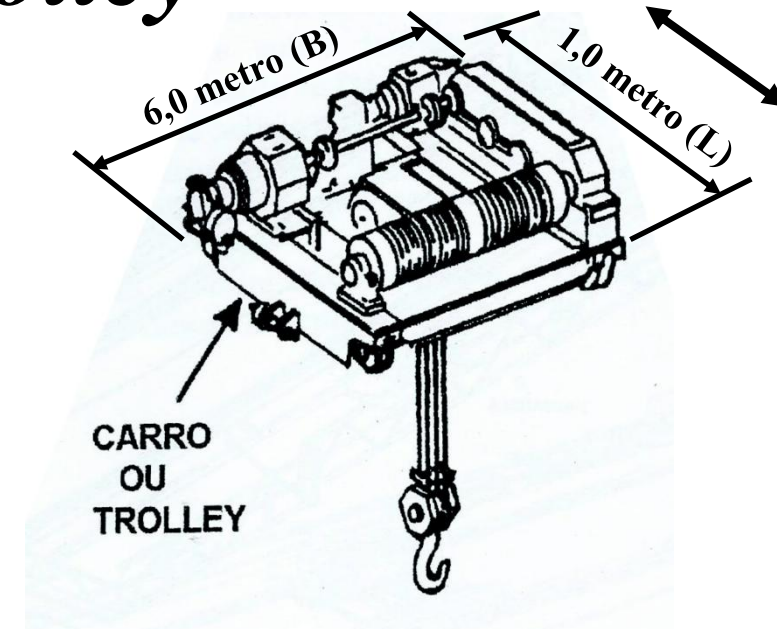
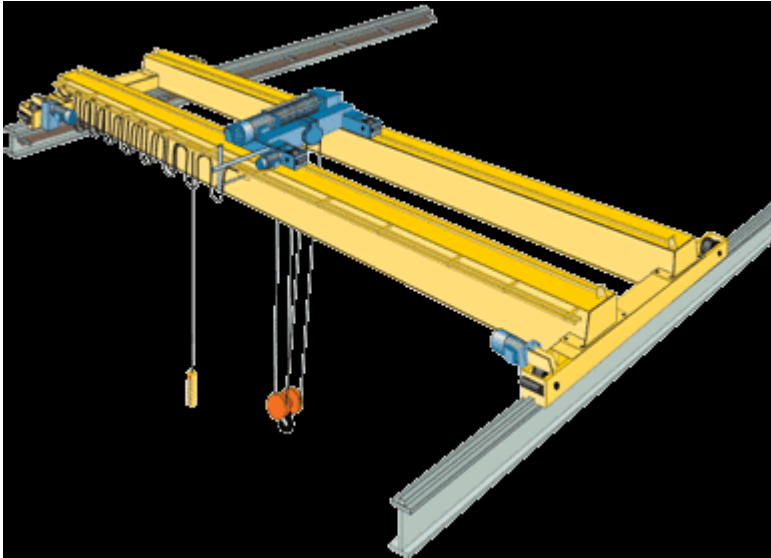
Descrição	Dimensão
<i>Length of Runway (L)</i>	60 metros
<i>Width of Runway (B)</i>	30 metros

Portal

Velocidade = 60 m/min. \approx 1.000 m/seg.

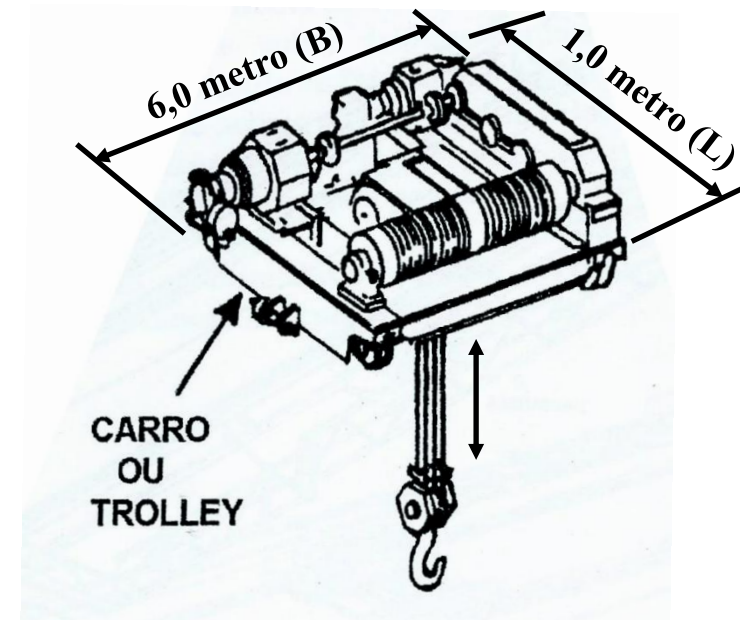
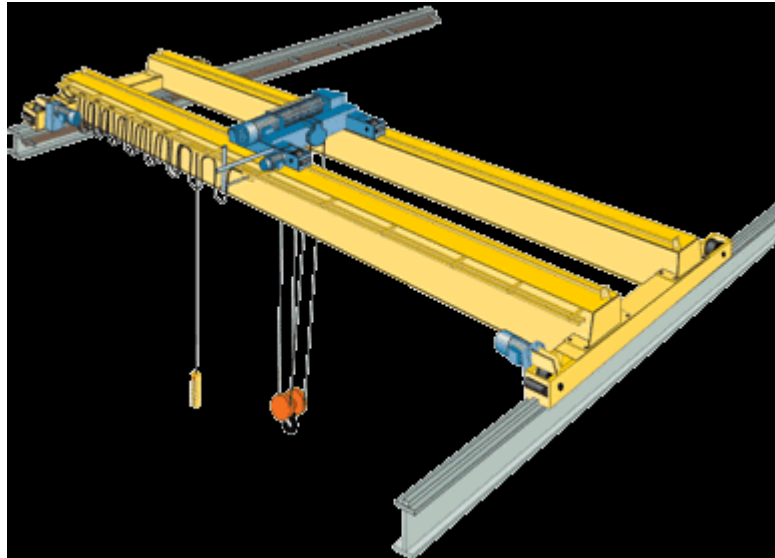


Trolly – carro ou *Trolley*



Descrição	Dimensão
<i>Length</i> (L)	1,0 metro
<i>Width</i> (W)	6,0 metro
<i>Height</i> (H)	1,0 metro
<i>Liftheight</i> (altura de elevação)	30 metros
<i>Speed</i>	0,67 metro / segundo

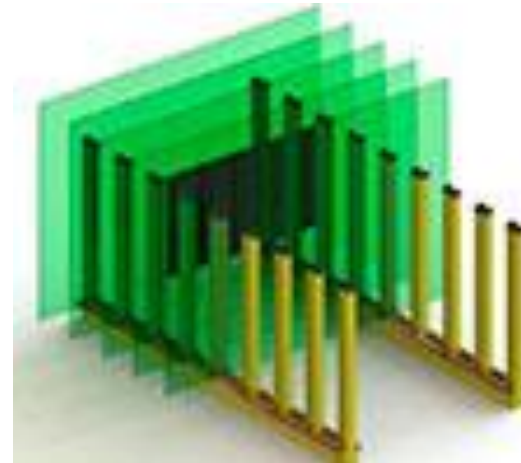
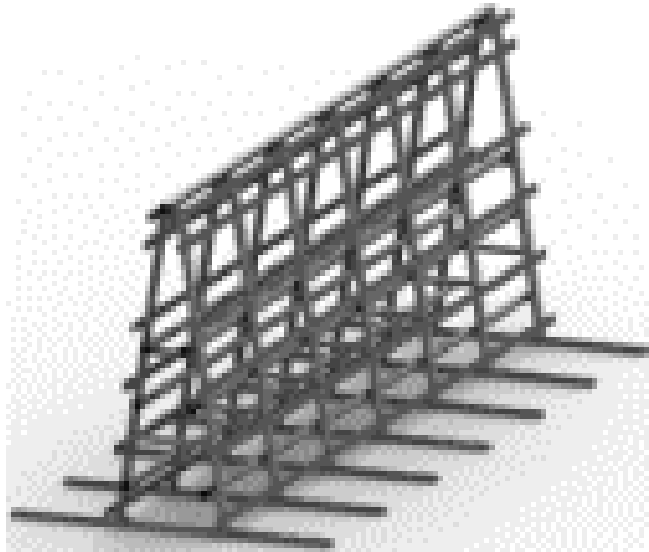
Hook – gancho/cabp



Descrição	Dimensão
<i>Height</i>	0,5 metros
<i>Speed</i>	0,25 metros / segundo

<http://www.inamaq.com.br/equipamentos.htm>

<https://www.ghcranes.com/pt/instalacoes/#estaleiros>



Dicas

*Lock Structure (bloqueio do *Frame*)*

Empilhadeira_5.spp - Tecnomatix Plant Simulation 12 - [Models.Frame (150%)]

File Home Debugger Window General Icons Vector Graphics

Print Find Object Unconnected Objects No Length Transfer Zoom In Original Size Zoom Out Scaling Factor Representation Shift Calendar Ribbon Tab Context Menu Background Replacement Mode Lock Structure Names Connections Comments Grid More

Actions Show Zoom Settings View Options

Class Library

- Basis (108/1000)
 - MaterialFlow
 - Fluids
 - Resources
 - InformationFlow
 - UserInterface
 - MUs
 - Entity
 - Container
 - Transporter
 - MUs
 - pallet
 - Empilhadeira
 - Rack
 - Plate
 - Tools
 - BottleneckAnalyzer
 - SankeyDiagram
 - EnergyAnalyzer
 - ExperimentManager
 - GAWizard
 - TransferStation
 - GanttWizard
 - GanttWizard
 - SequentialSampler
 - StatisticalTools
 - Tools
 - DistributedSimulation
 - Models
 - Frame
 - ApplicationObjects
 - KanbanObjects
 - Machines3D

Toolbox

Material Flow Fluids Resources Information Flow User Interface Mobile_Units Statistical Tools Tools Tools: Kanban Machines 3D

Bloqueia qualquer alteração do Frame

EventController Init rack_loadtime=10.0000 plates_changetime=30.0000

warehouse_loadtime=25.0000

Rack_Empty

RouRoute2

Route4

Empilhadeira_WII

R_1_3

R_1_2

R_1_1

R_2_3

R_2_2

R_2_1

cycle_P1_A=2

P1_A P1 P1_F

Chart

cycle_P2_A=2

P2_A P2

plates_ful

plates_empty

Drain1

Drain Rack_fillec Empilhadeira_job Shift_Calendar

***Inherit* (alterar *Pick Color* para cursor do *mouse*)**

Empilhadeira_5.spp - Tecnomatix Plant Simulation 12 - [Models.Frame (150%)]

File Home Debugger Window General Icons Vector Graphics

Open Event Controller Animation Navigate Edit Objects Model

Class Library

- Basis (108/1000)
- MaterialFlow
- Fluids
- Resources
- InformationFlow
- UserInterface
- MUs
- Entity
- Container
- Transporter
- MUs
- pallet
- Empilhadeira
- Rack
- Plate

Material Flow Fluids Resources Information Flow User Interface Mobile_Units Statistical Tools Tools Tools: Kanban Machines 3D

rack_loadtime=10.0000 plates_changetime=30.0000

warehouse_loadtime=25.0000

Empilhadeira_WII

RouRoute2 Route4

cycle_P1_A=2

P1_A P1 P1_E

Chart

cycle_P2_A=2

P2_A P2 P2_E

plates_ful

plates_empty Drain1

Shift_Calendar

Empilhadeira_job

Open Enter

- Duplicate
- Derive
- Cut Inheritance
- Delete Delete F2
- Rename
- Show Origin
- Show Inheritance
- Show MU Statistics
- Show Attributes and Methods F8
- Edit Icons...**
- Print...
- Find Object... F3
- Save Object As...

Empilhadeira_5.spp - Tecnomatix Plant Simulation 12 - [.MUs.Plate]

File Home Debugger Window Edit Animation General

New Import Export Size Transparent Apply Changes Overview Inherit Zoom In Zoom Out Drawing Color Pick Color Freehand Line Polyline Ellipse Rectangle Filled Rectangle Fill Area Copy/Paste Area Paste Area Replace Color Reference Point

Class Library

Material Flow Fluids Resources Information Flow User Interface Mobile_U

Tools: Kanban Machines 3D

Draw Freehand
Draw a free-form line.

Number: 0/2 Name: Operational Current

Icon | Empilhadeira_5.spp - Tecnomatix Plant Simulation 12 - [.MUs.Plate]

File Home Debugger Window Edit Animation General

New Import Export Size Transparent Apply Changes Overview Inherit Zoom In Zoom Out Drawing Color Pick Color Freehand Line Polyline Ellipse Rectangle Filled Rectangle Fill Area Copy/Paste Area Paste Area Replace Color Reference Point

Class Library

- Basis (108/1000)
 - MaterialFlow
 - Fluids
 - Resources
 - InformationFlow
 - UserInterface
 - MUs
 - Entity
 - Container
 - Transporter
 - MUs
 - pallet
 - Empilhadeira
 - Rack
 - Plate
 - Tools
 - BottleneckAnalyzer
 - SankeyDiagram
 - EnergyAnalyzer
 - ExperimentManager
 - GAWizard
 - TransferStation
 - GanttWizard
 - SequentialSampler
 - StatisticalTools
 - Tools
 - DistributedSimulation
 - Models
 - Frame
 - ApplicationObjects
 - KanbanObjects
 - Machines3D

Toolbox

Material Flow Fluids Resources Information Flow User Interface Mobile_Units Statistical Tools Tools Tools: Kanban Machines 3D

Number: 0/2 Name: Operational Current

Muda o cursor do conta gotas (*Pick Color*) para o curso do mouse (*Freehand*)

