

# ME1000

## RF Circuit Design Courseware

### Teaching slides

- Editable Microsoft® PowerPoint® slides
- Covers 90 hours of teaching

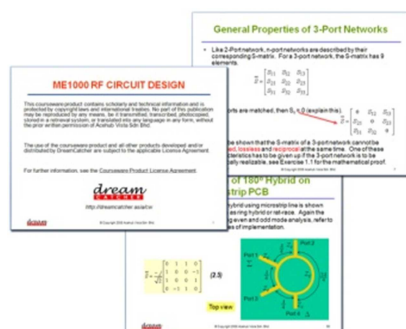

### Training kit

- RF transceiver kit
- Lab sheets & model answers
- Problem-based assignments
- Covers 48 hours of labs

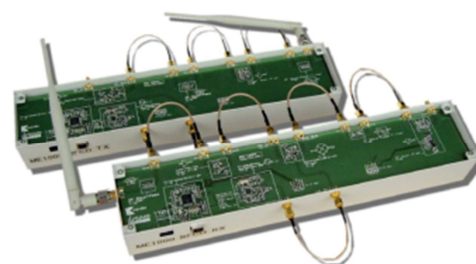

Target university subject	Target year of study	Prerequisite(s)
RF Circuit Design—Passive	3 <sup>rd</sup> Year or Final year undergraduate	Electromagnetic Theory
RF Circuit Design—Active	Final year undergraduate or postgraduate	RF Circuit Design—Passive

The ME1000 serves as a ready-to-teach package in the areas of RF and wireless communications. This is a lecturer resource consisting of teaching slides, training kits, lab sheets, and problem-based assignments.

### Designed to impart knowledge in

- Basic RF concepts
- RF circuit design concepts
- RF communication systems concepts
- RF circuit characterization
- RF Electronic Design Automation (EDA) software usage
- RF circuit simulation and construction
- RF measurement instruments usage
- Measurement automation

### Benefits of the ME1000 courseware

- The RF transceiver kit consists of module-based transmitter and receiver units, providing students with the flexibility to mix and match training kit modules to build any RF subsystem.
- The transparent casing on the units allows their circuit board to be viewed easily, allowing students to easily understand how circuits are built and how component placement affects circuit performance.
- The provided CAE design files (based on ADS and Genesys software from Agilent Technologies) allow lecturers to demonstrate RF circuit design principles, modeling, and simulation techniques.
- A Measurement Automation Program provided with the training kit demonstrates how graphical programming is used to control instruments, automate measurement, and process test results.
- The RF transceiver kit is powered via USB, eliminating the need to use separate power supplies.



## Teaching Slides

More than 1000 editable Microsoft PowerPoint teaching slides, covering 90 hours of teaching for two full semesters are provided. The slides cover the following topics:

- Advanced Transmission Line Theory
- Transmission Line Circuits and RF Microwave Network Analysis
- Impedance Transformation and Impedance Matching
- RF Microwave Filters
- 3-Port and 4-Port Microwave Components
- Coaxial Components and Rectangular Waveguide Components
- Passive and Active RF Lumped Components
- Small-Signal Amplifier Theory
- SSA Design—Maximum Power Gain and Fixed Transducer Power Gain
- SSA Design—Low-Noise Amplifier
- SSA Design—Constant Mismatch and Effective Power Gain
- General Single-Stage SSA Design
- Multistage SSA Design
- RF Oscillator
- High Power Circuits
- Broadband Amplifiers



## Training Kit

### RF transceiver kit

The RF transceiver kit consists of a transmitter unit and a receiver unit. The units are made up of various RF modules to form both the transmitter and receiver sections of a superheterodyne system.

The transceiver kit is controlled by a Windows®-based Control Panel software via USB. A Measurement Automation Program is provided to demonstrate automated characterization and test of RF circuits. A signal generator and a spectrum analyzer are required to run this program.

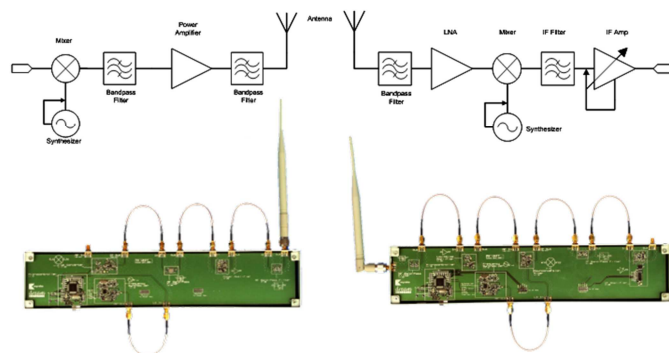

### Accessories

The following accessories are provided with the training kit.

Item	Quantity
TRM standard calibration kit	1
USB cable	3
SMA(m)-to-SMA(m) jumper cable, 0.18 m	9
SMA(m)-to-SMA(m) coaxial cable, 1 m	2
N(m)-to-SMA(f) adapter	2
RF power combiner	1
Antenna	2
Ground cable, 1 m	2



Note: A PC with Windows® XP, Windows® Vista or Windows® 7 is required to operate the Control Panel software for controlling the RF transceiver kit.

## Lab sheets

The training kit includes 16 lab sheets in editable Microsoft® Word format. Each lab requires 3 hours to complete. Model answers are provided with all lab sheets. The required instruments for the labs are listed below.

Lab Sheet	Required Items		
	Option 1 RF Signal Generator & Spectrum Analyzer	Option 2 Vector Network Analyzer	Option 3 RF Signal Generator, Spectrum Analyzer, & Vector Network Analyzer
Calibration with Spectrum Analyzer	√		√
Calibration with Vector Network Analyzer		√	√
Power Amplifier Characterization Using Spectrum Analyzer <sup>[1]</sup>	√		√
Power Amplifier Characterization Using Vector Network Analyzer		√	√
Low-Noise Amplifier Characterization Using Spectrum Analyzer	√		√
Low-Noise Amplifier Characterization Using Vector Network Analyzer <sup>[2]</sup>		√	√
Low-Noise Amplifier Characterization Using Noise Figure Analyzer <sup>[3]</sup>			
Filter Characterization Using Spectrum Analyzer	√		√
Filter Characterization Using Vector Network Analyzer		√	√
Mixer Characterization Using Spectrum Analyzer	√		√
Mixer Characterization Using Vector Network Analyzer		√	√
Frequency Synthesizer Characterization Using Spectrum Analyzer	√		√
Measurement Automation Using Agilent VEE	√		√
Antenna Reflection Measurement with Vector Network Analyzer		√	√
Antenna Gain Measurement with Spectrum Analyzer	√		√
End-to-End RF Transceiver Measurement	√		√

[1] The third-order inter-modulation measurement in this lab sheet requires an additional signal generator.

[2] Extra exercises on transmission measurements in this lab sheet require a network analyzer with vector S12/S21 measurement capability.

[3] This lab requires a noise figure analyzer.

## Problem-based assignments

The problem-based assignments below allow students to enhance their problem-solving skills.

- Maximum Operating Distance Measurement Using Spectrum Analyzer
- Maximum Operating Distance Measurement Using Oscilloscope
- RF Bandpass Filter Design
- RF Amplifier Design



## Instruments

The recommended instruments and software from Agilent Technologies, to be purchased separately, are listed below.

Instrument / Software <sup>[1]</sup>	Model <sup>[2]</sup>
RF Signal Generator & Spectrum Analyzer	N9310A RF Signal Generator, 9 kHz to 3 GHz <sup>[3]</sup> N9320B 3 GHz RF Spectrum Analyzer, 9 kHz to 3 GHz
Vector Network Analyzer	N9912A FieldFox RF Analyzer, 4 GHz [with option 104, 110, 303] <sup>[4]</sup>
Noise Figure Analyzer	N8973A Noise Figure Analyzer, 10 MHz to 3 GHz N4000A SNS Series Noise Source, 10 MHz to 18 GHz (ENR 6 dB)
EDA Software <sup>[5]</sup>	W1328BP Genesys Core, Synthesis, Circuit, System, RF Bundle or E8975L Advanced Design System

[1] Refer to the Lab sheets section for the instrument selection.

[2] The courseware is designed to work with these instruments and software. Other models with equivalent performance may be used with alterations to the lab procedures.

[3] An additional signal generator is required for the third-order inter-modulation measurement in the Power Amplifier Characterization lab.

[4] This instrument only performs scalar S12/S21 measurements. It may be replaced by a network analyzer with full vector measurement capability to perform the extra lab exercises.

[5] This software is used for the problem-based assignments.

# Training Kit Hardware Specifications

	RF Transmitter Unit	RF Receiver Unit
<b>RF</b>		
Frequency synthesizer output power	-4.5 dBm (typical)	
Frequency synthesizer frequency range	816 MHz to 880 MHz	816 MHz to 880 MHz
Antenna frequency range	806 MHz to 960 MHz	806 MHz to 960 MHz
Antenna length	210 mm	210 mm
<b>General</b>		
Power source		USB
EMC designed to		Class B, Part 15 of FCC
Warranty		1 year

## Ordering Information

Description	Package	Product Number
Teaching Slides	1 user license	ME1000-100
Training Kit	1 set	ME1000-200
Teaching Slides + Training Kit	1 user license + 1 set	ME1000-300
Instruments	where applicable	Purchase separately from Agilent or its distributor

Training courses related to subject matter are available on request. Visit [dreamcatcher.asia](http://dreamcatcher.asia) for details.

For more information or enquiries:

Website: [dreamcatcher.asia/cw](http://dreamcatcher.asia/cw)  
E-mail: [cw.sales@dreamcatcher.asia](mailto:cw.sales@dreamcatcher.asia)

Acehub Vista Sdn Bhd (785702-P)  
*A member of the DreamCatcher group*  
10, Persiaran Mahsuri 1/2  
Sunway Tunas, 11900 Bayan Lepas  
Malaysia

© 2010-2011 Acehub Vista Sdn Bhd

We reserve the right to change or alter the information in this material without prior notice. The information provided in this material is accurate as of the print date.

Microsoft, Windows, and Office Programs are trademarks of Microsoft Corporation in the United States and/or other countries. All other copyrights and trademarks belong to their respective owners.

Updated on 29 Dec 2011

*dream*  
CATCHER