



Escola Politécnica da Universidade de São Paulo
PPGEE - PSI5121 Sistemas Automotivos



Aula 3 – Modelamento cinemático e dinâmico

Prof. Leopoldo Yoshioka
4 DE JULHO 2023



Sistema de coordenadas

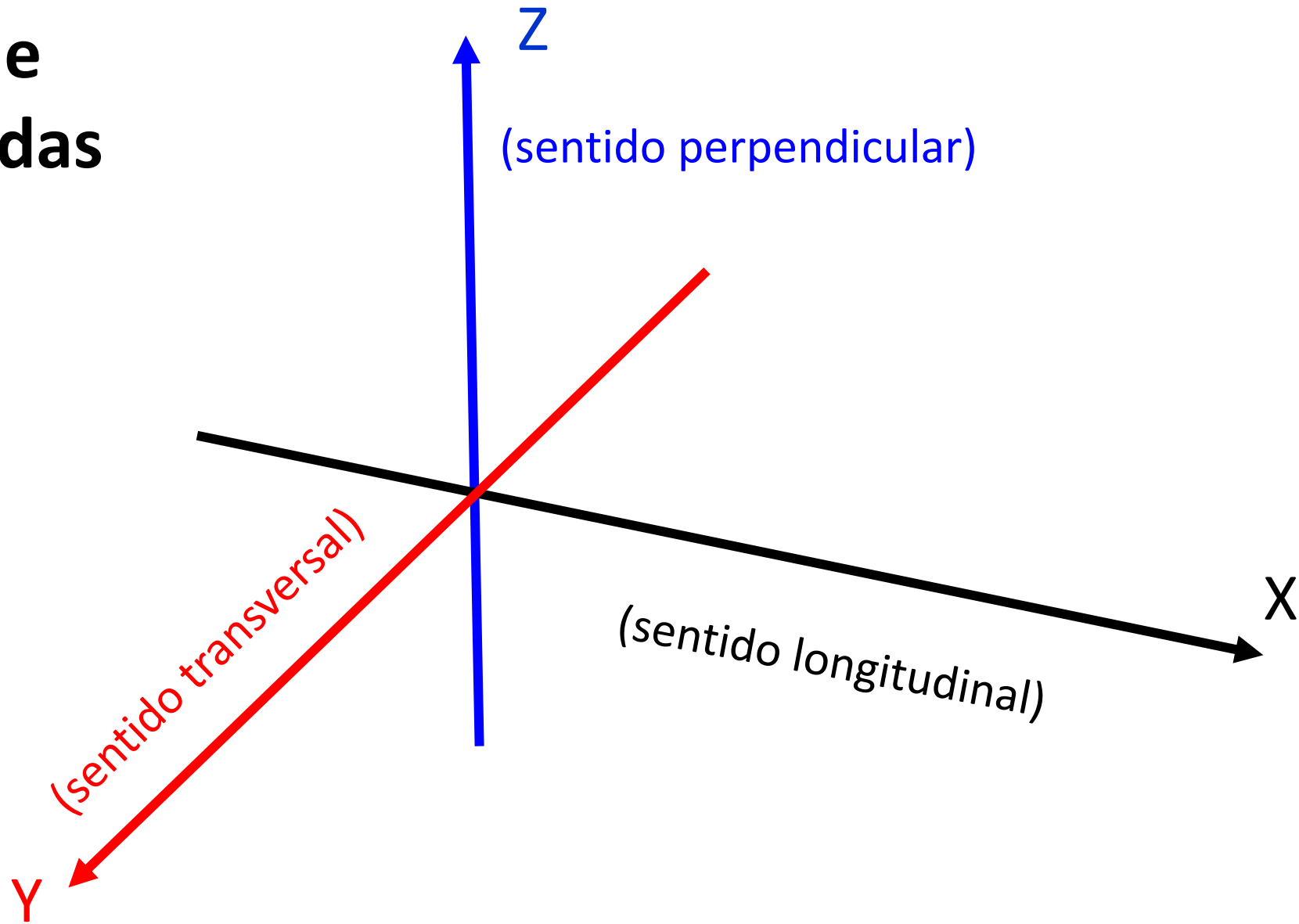

USP

PSI5121

Definições



USP
PSI5121

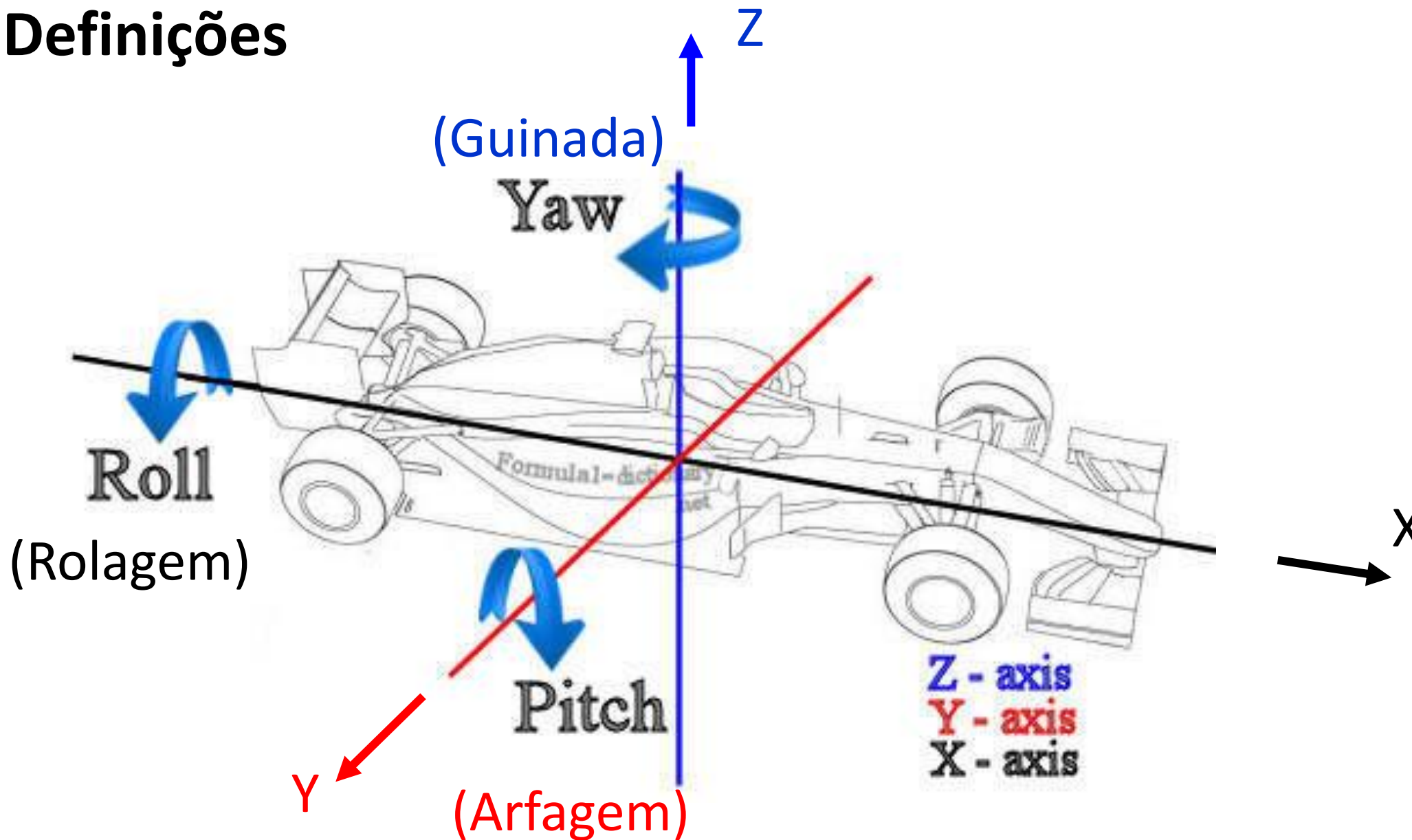

Controle

Entrada

Saída

Planta (modelo)



Trajectoria resultante

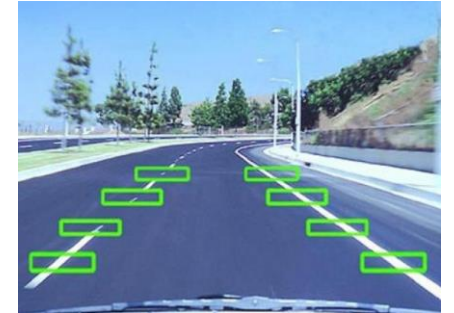

Velocidade resultante

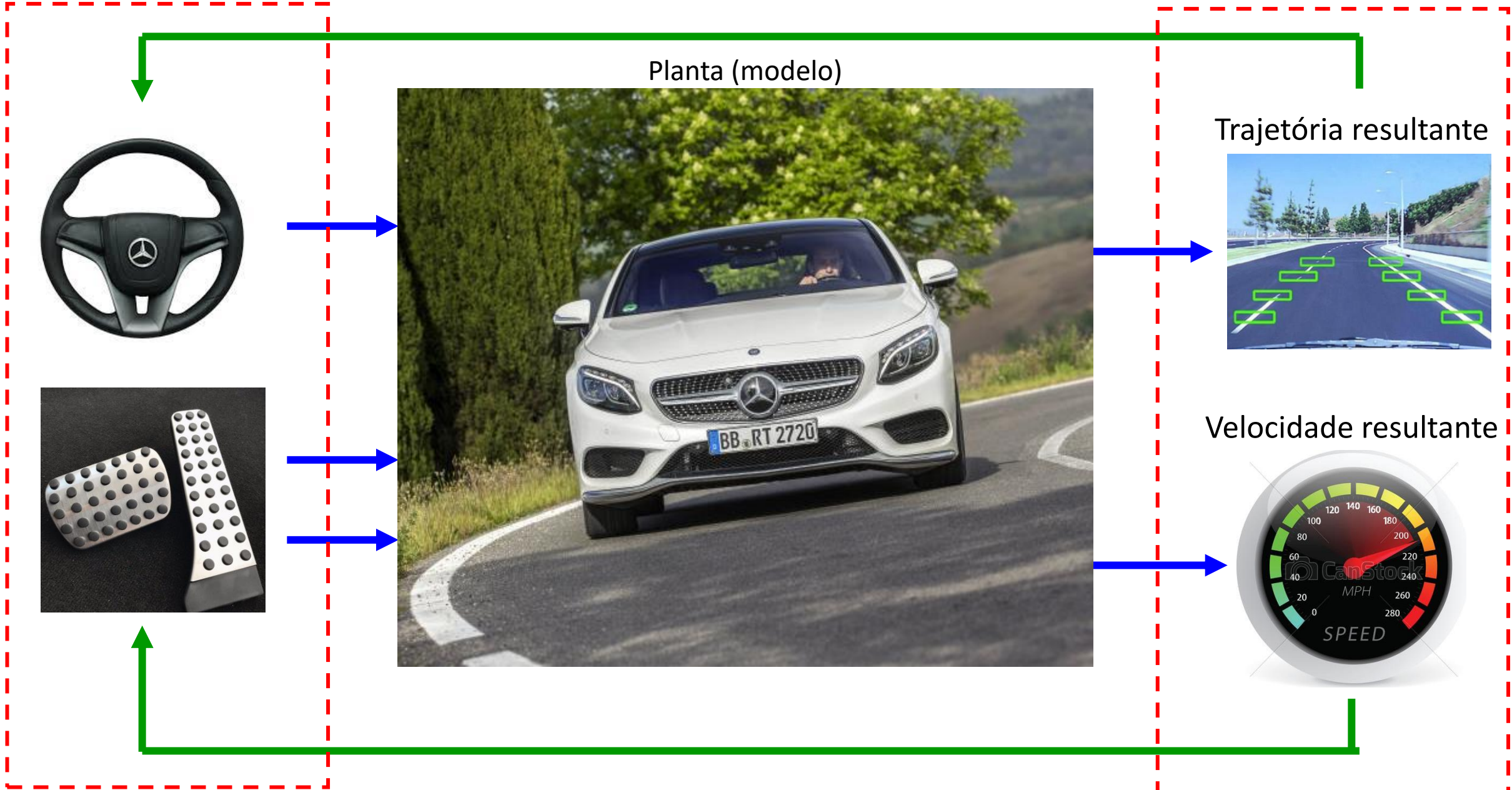



Modelo de controle lateral e longitudinal do veículo

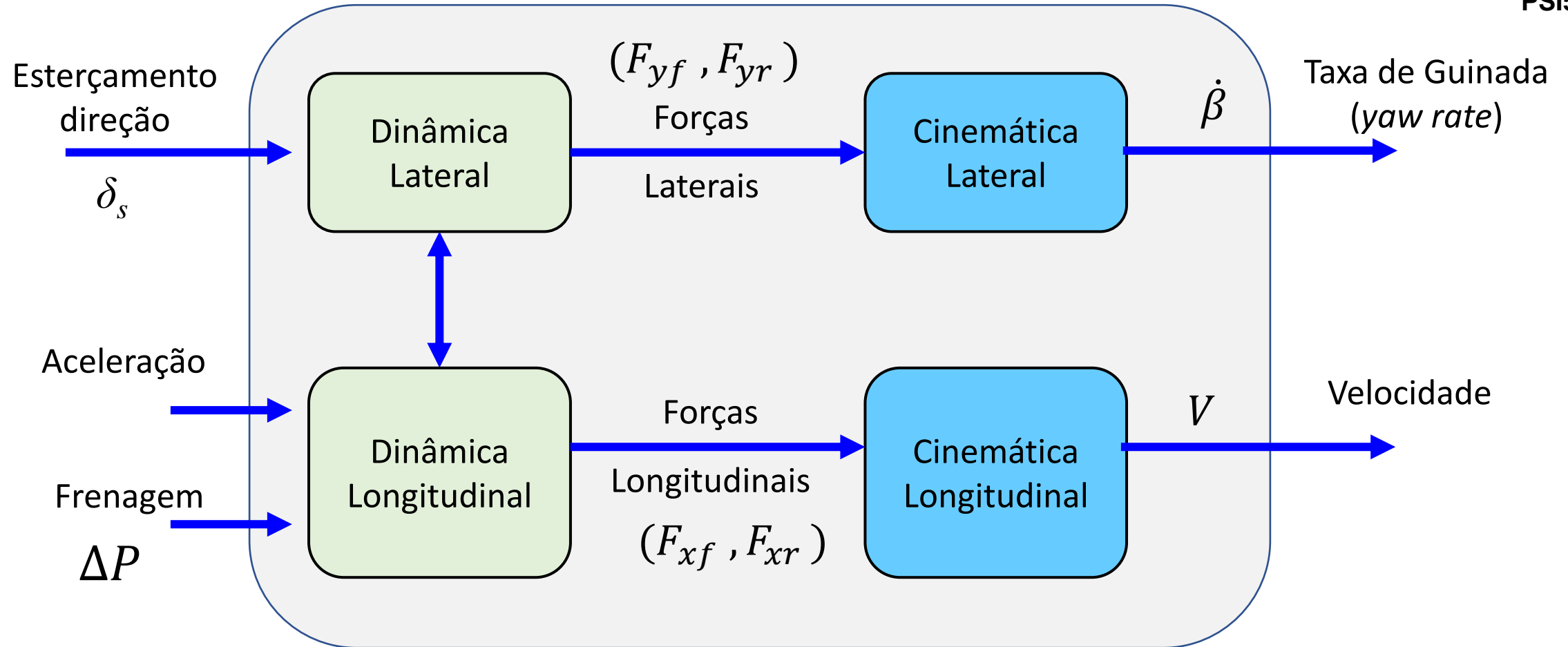

Objetivo: manter o veículo na trajetória definida com a velocidade desejada

Modelamento cinemático e Modelamento dinâmico do veículo



USP

PSI5121

Modelamento cinemático:

- considera somente os **parâmetros geométricos** do veículo e da via
- costuma ser suficiente para representar o comportamento do veículo em **baixas velocidades**

Modelamento dinâmico:

- considera todos os componentes do veículo, as **forças** e os **momentos de inércia** envolvendo o veículo e a via.
- Necessário para representar o veículo em **altas velocidades** ou em condições de **irregularidades** do pavimento e **instabilidade** devido a derrapagens



USP

PSI5121

Modelo cinemático do movimento lateral do veículo

- As equações do movimento são baseados puramente nas relações geométricas do sistema

Modelo Cinemático do movimento lateral do veículo



USP
PSI5121

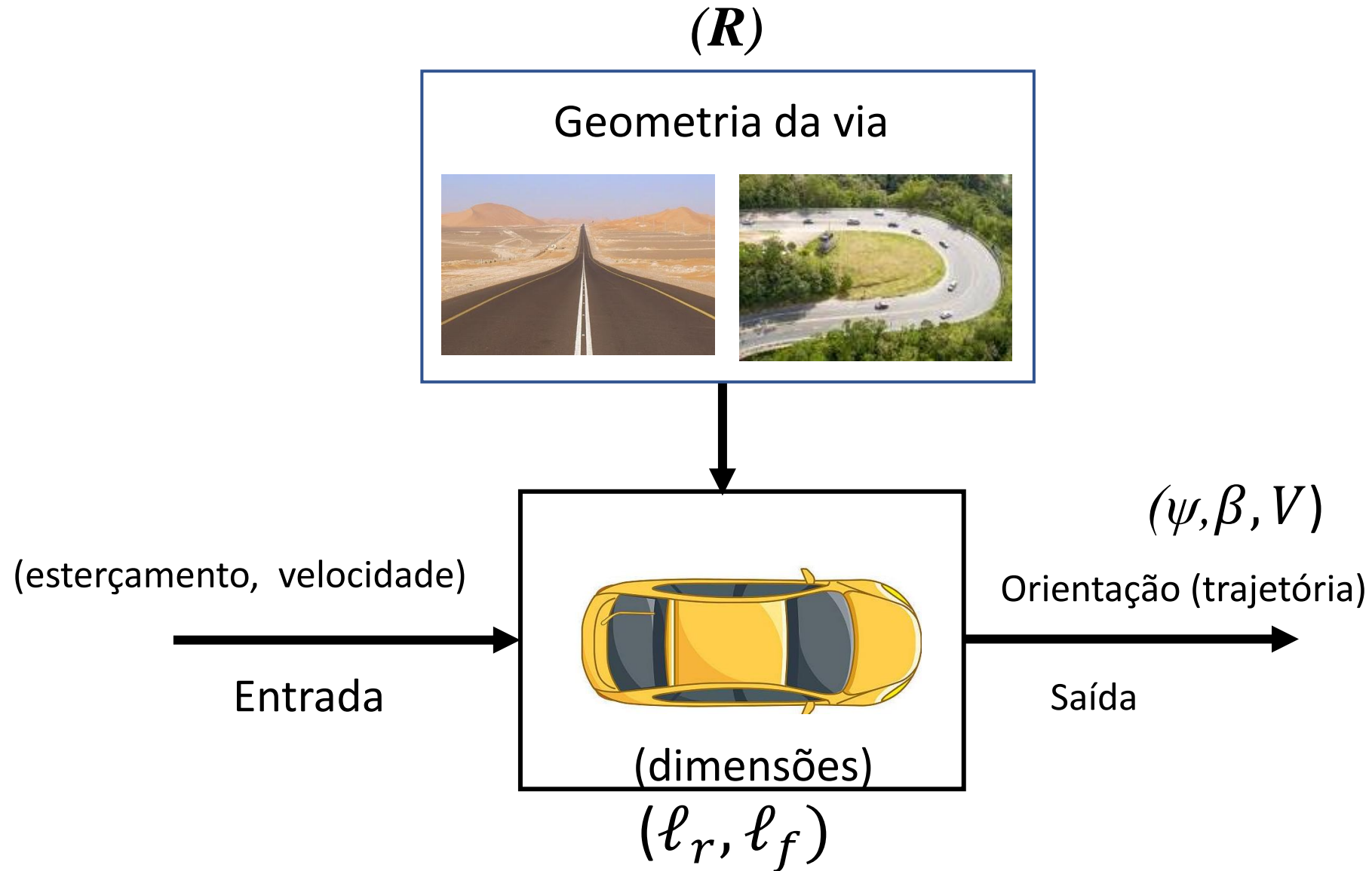



Modelo bicicleta (*Bicycle model – Ackerman steering model*)

Y

C: centro de gravidade (c.g.)

$L = l_r + l_f$ distância entre eixos

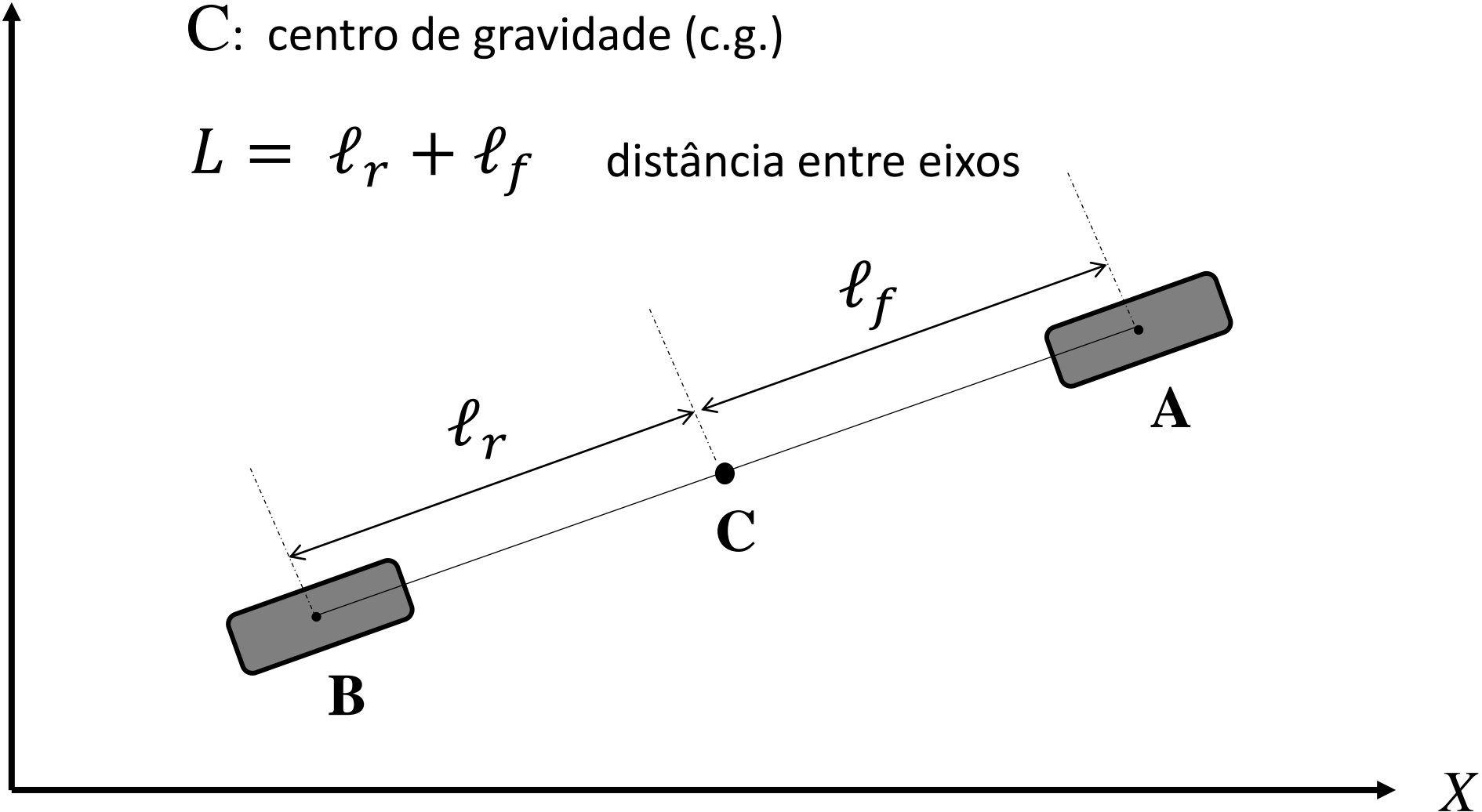

Modelo cinemático numa trajetória linear



USP
PSI5121

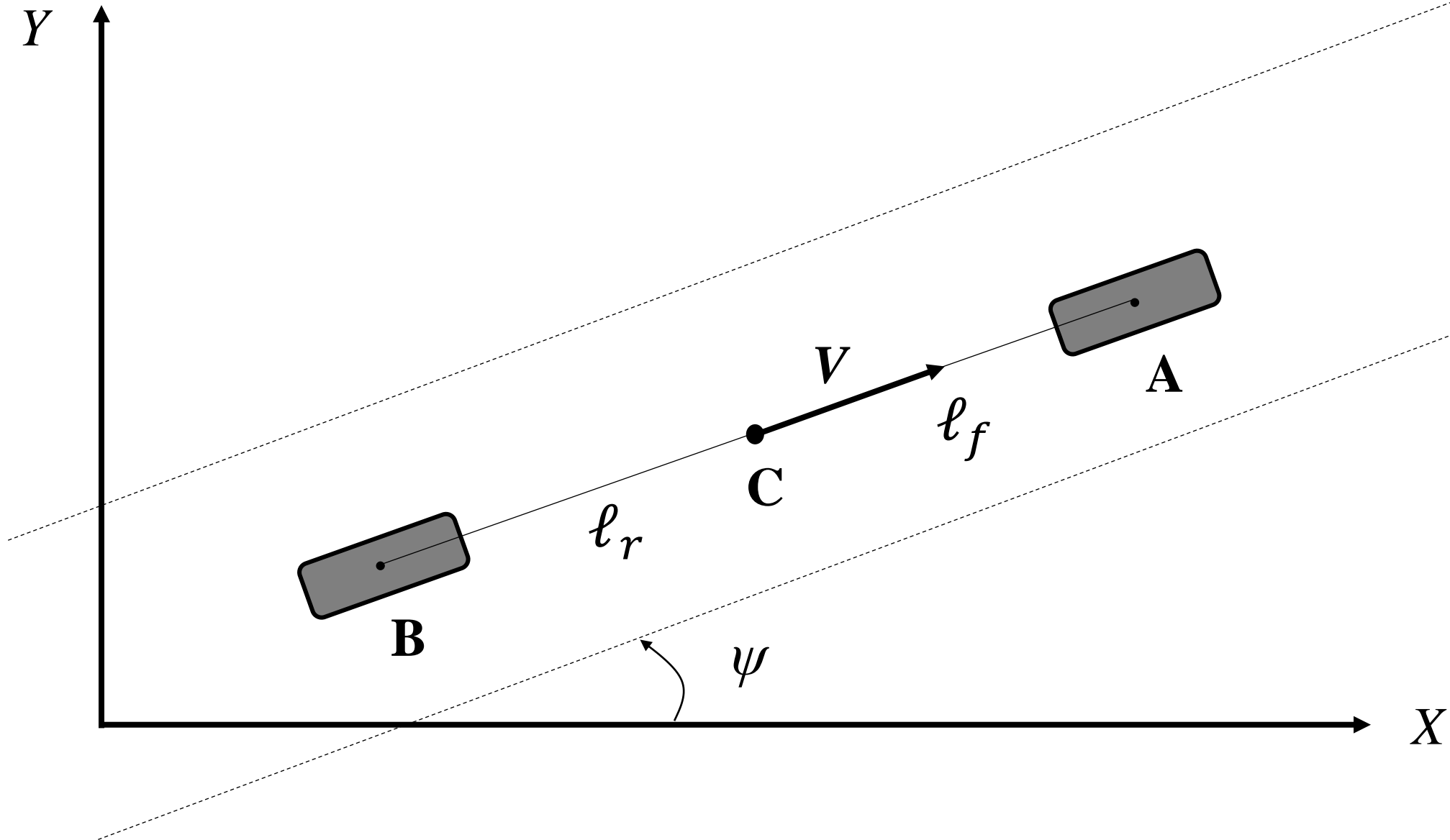

Trajetória curva



USP
PSI5121

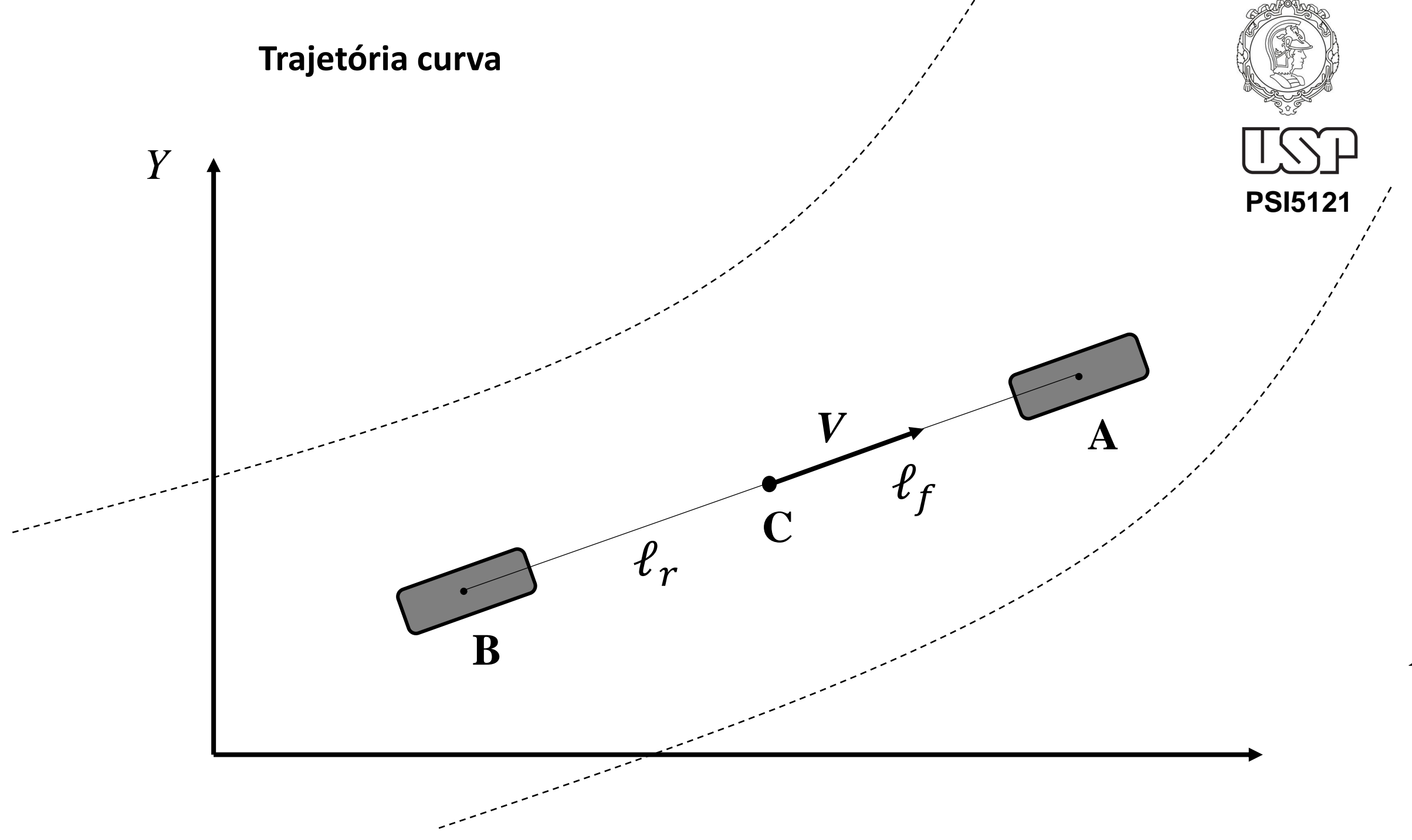



USP
PSI5121

Trajetoória curva

Y

δ_r ângulo roda traseira

δ_f ângulo roda dianteira

β ângulo guinada (*yaw*)

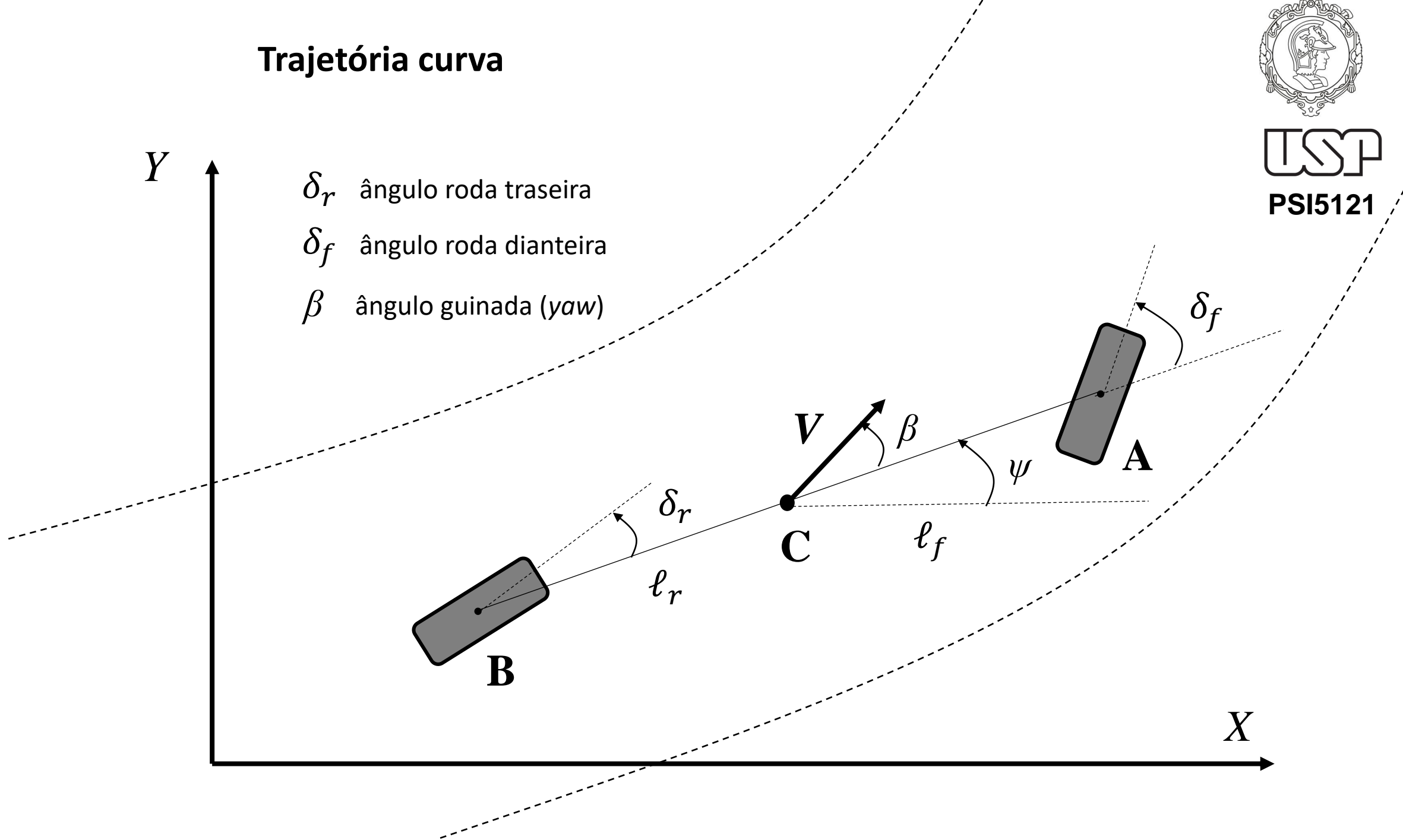

Modelo cinemático do movimento lateral do veículo



USP
PSI5121

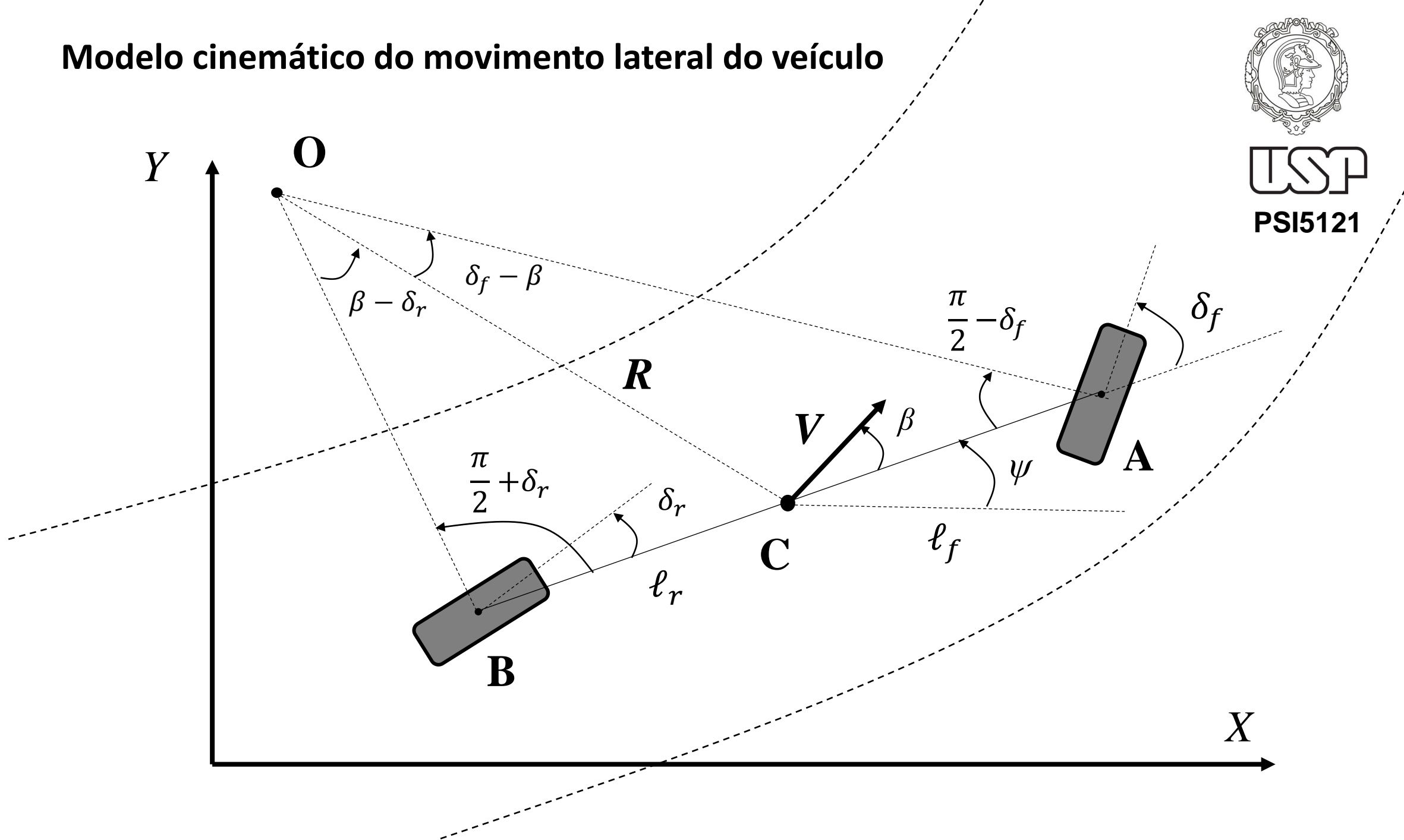



USP

PSI5121

Modelo cinemático do movimento lateral do veículo

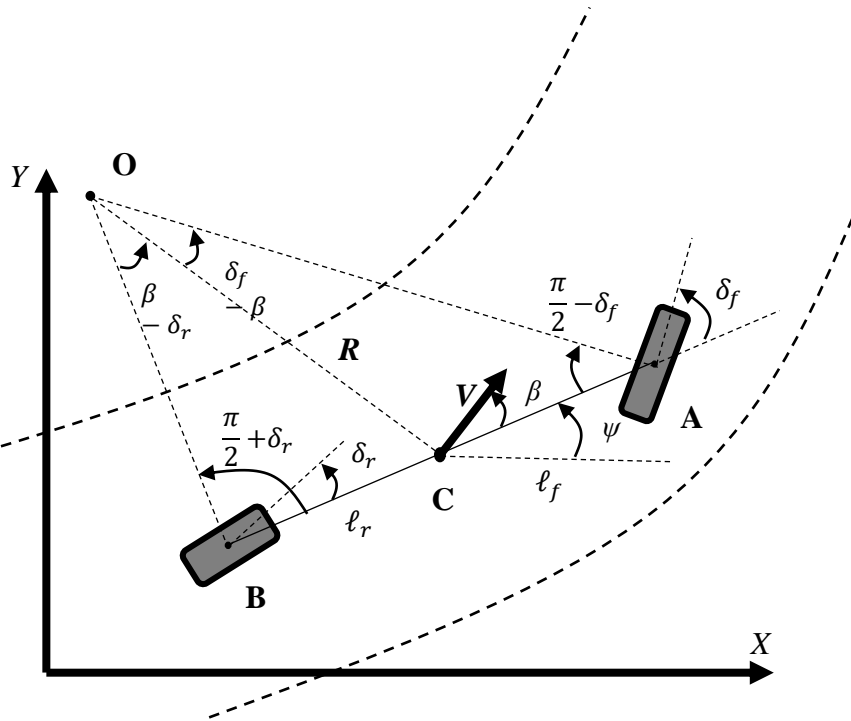

- Assume-se que o veículo faz movimento planar
- São necessárias três coordenadas para descrever o movimento do veículo: X, Y, Ψ
- X e Y são coordenadas inerciais do c.g.
- Ψ descreve a orientação do veículo.
- A velocidade do veículo, V , faz um ângulo β com o eixo longitudinal do veículo
- O ângulo β é chamado de ângulo de guinada do veículo.

Este modelo representa bem o comportamento do veículo para baixas velocidades (menor que 5 m/s)



USP
PSI5121

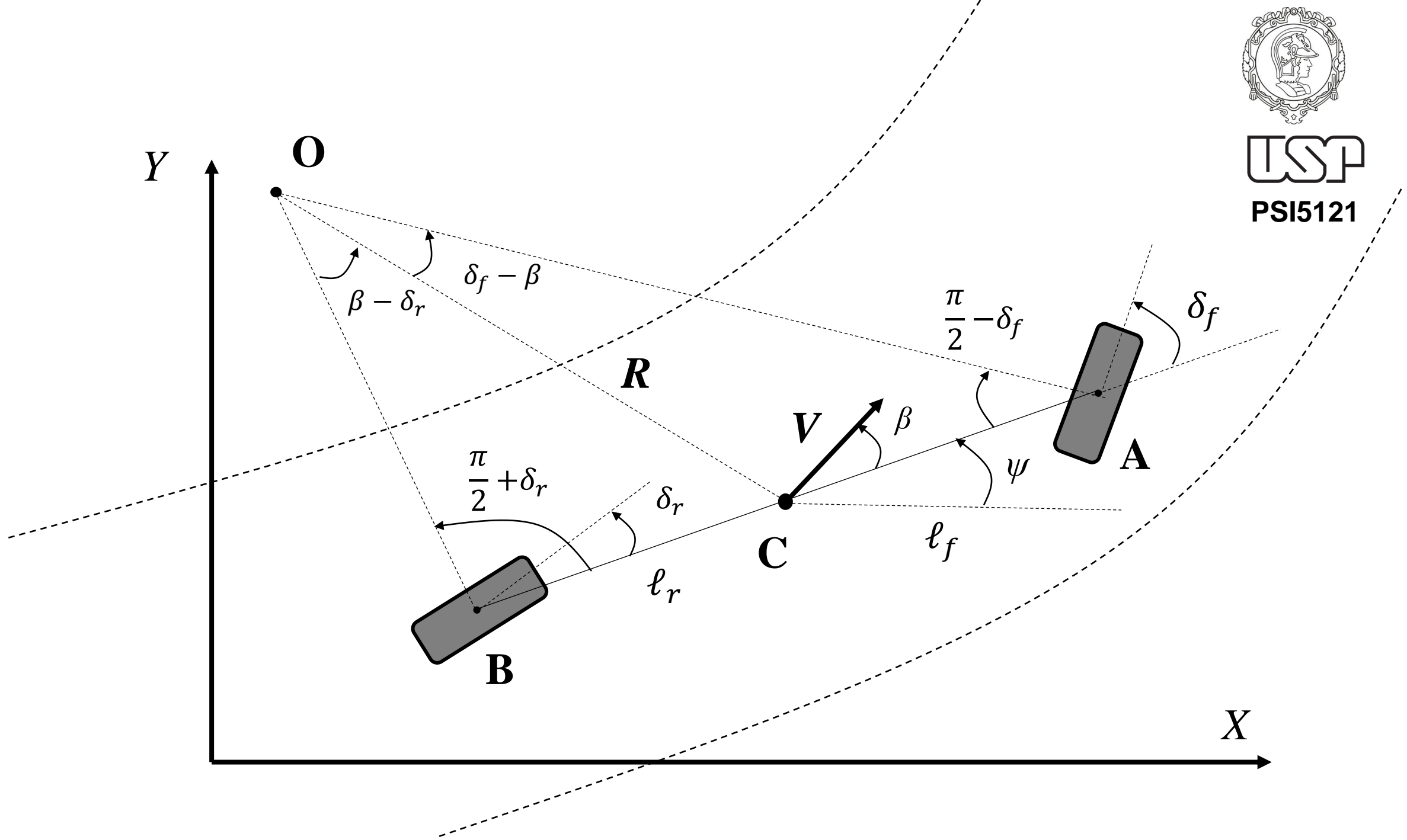



USP
PSI5121

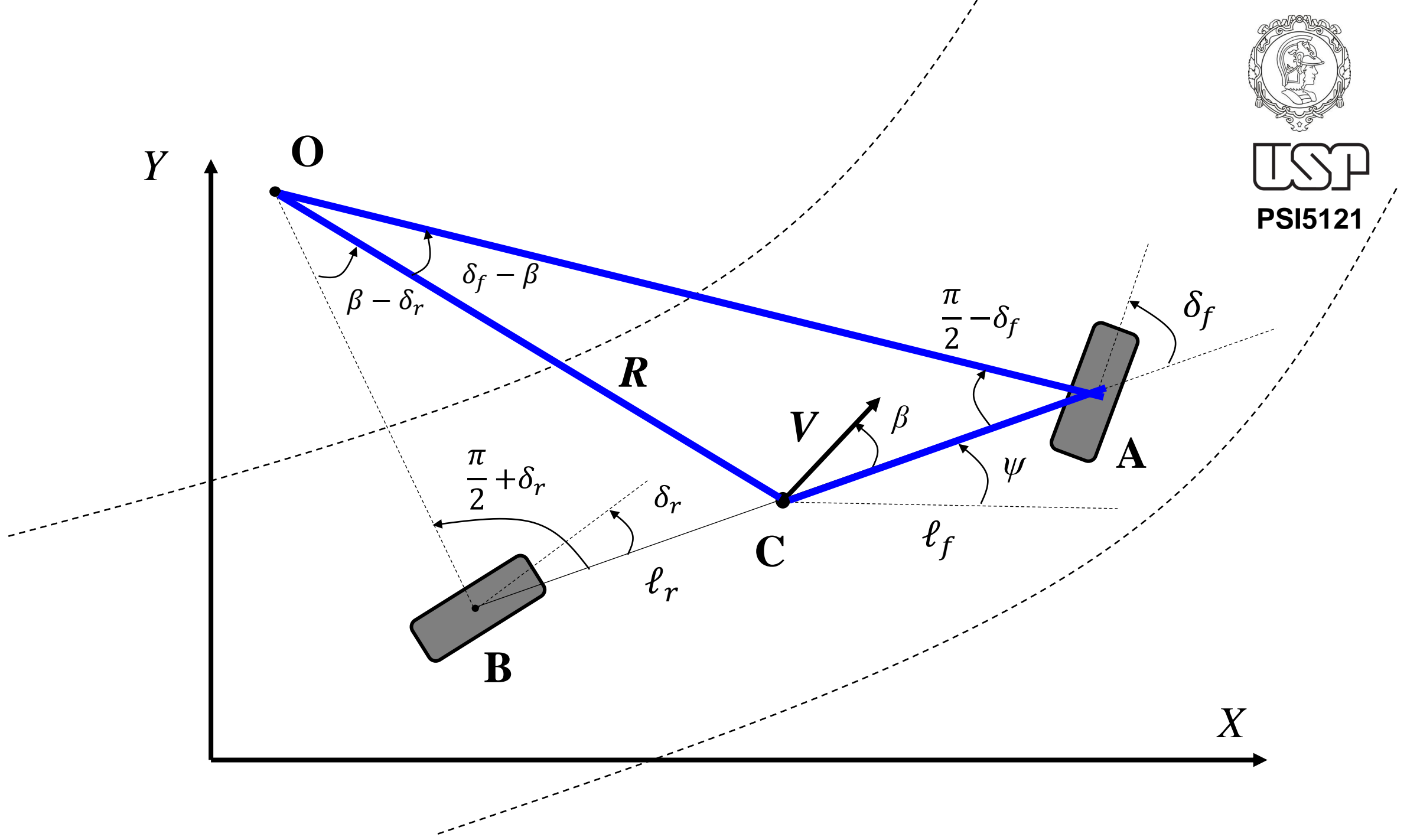



USP

PSI5121

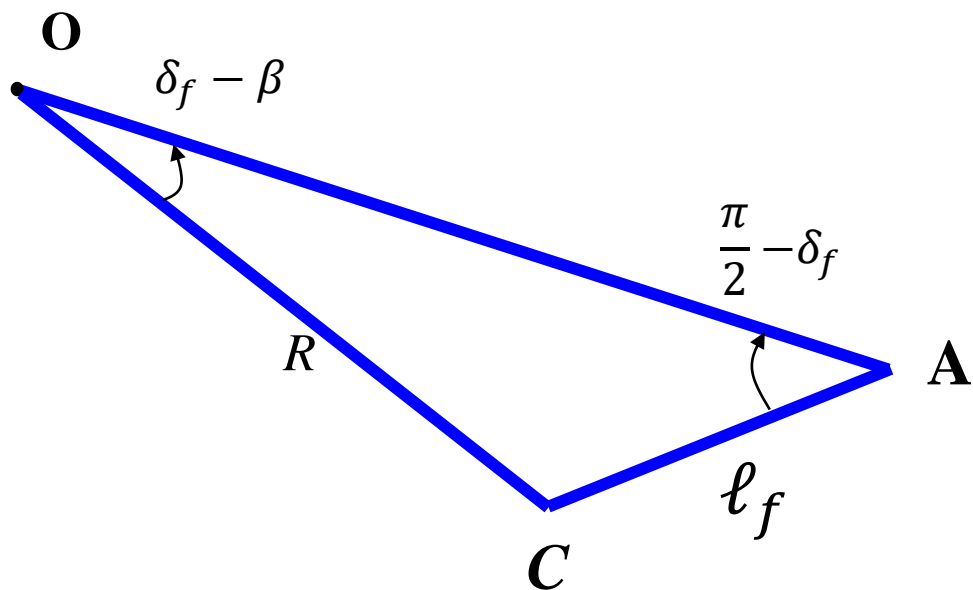

Aplicando lei dos senos no triângulo **OCA**:

$$\frac{\text{sen}(\delta_f - \beta)}{l_f} = \frac{\text{sen}(\frac{\pi}{2} - \delta_f)}{R}$$

(1)

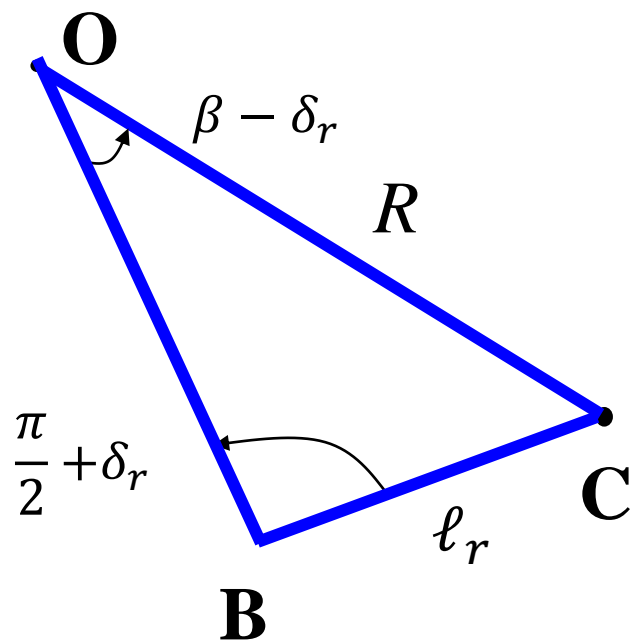

Aplicando lei dos senos no triângulo **OCB**:

$$\frac{\text{sen}(\beta - \delta_r)}{l_r} = \frac{\text{sen}(\frac{\pi}{2} + \delta_r)}{R}$$

(2)



Aplicando-se as propriedades trigonométricas nas equações (1) e (2), chega-se à seguinte equação:

$$\{\tan(\delta_f) - \tan(\delta_r)\}\cos(\beta) = \frac{\ell_f + \ell_r}{R} \quad (3)$$

Assumindo que o raio da trajetória do veículo, R , varia lentamente, pode-se considerar que a taxa de variação da orientação, $\dot{\psi}$, é igual à velocidade angular do veículo, ω . Como $\omega = V/R$ tem-se que:

$$\dot{\psi} = \frac{V}{R} \quad (4)$$

Usando a equação (4), a equação (3) pode ser reescrita:

$$\dot{\psi} = \frac{V \cos(\beta)}{\ell_f + \ell_r} \{\tan(\delta_f) - \tan(\delta_r)\} \quad (5)$$



USP

PSI5121

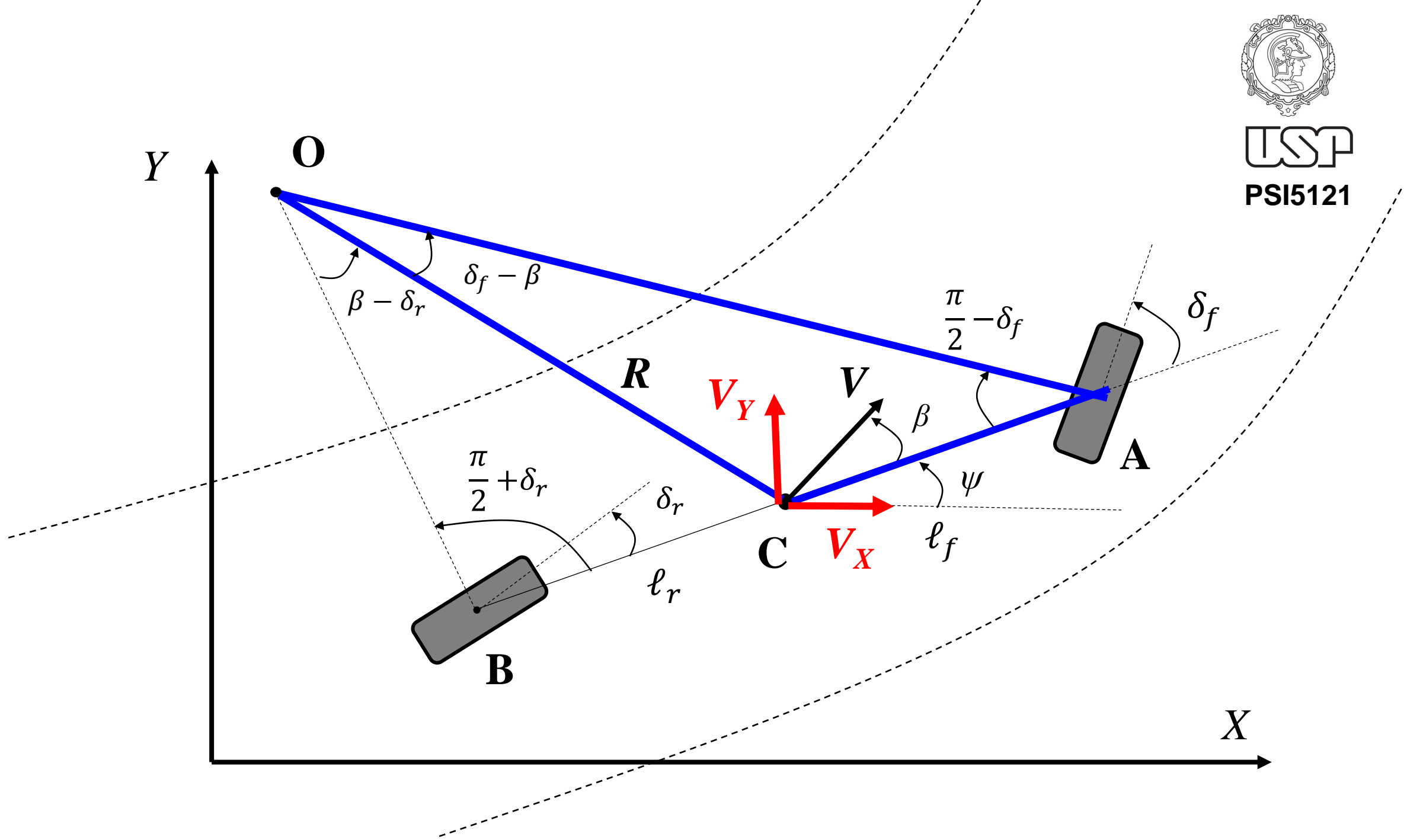



USP

PSI5121

Assim, as equações que descrevem o movimento do veículo são as seguintes:

$$V_X = \dot{X} = V \cos(\psi + \beta) \quad (6)$$

$$V_Y = \dot{Y} = V \sin(\psi + \beta) \quad (7)$$

$$\dot{\psi} = \frac{V \cos(\beta)}{\ell_f + \ell_r} \{ \tan(\delta_f) - \tan(\delta_r) \} \quad (8)$$

$$\beta = \tan^{-1} \left(\frac{\ell_f \tan(\delta_r) + \ell_r \tan(\delta_f)}{\ell_f + \ell_r} \right) \quad (9)$$

Modelo Cinemático do veículo



USP
PSI5121

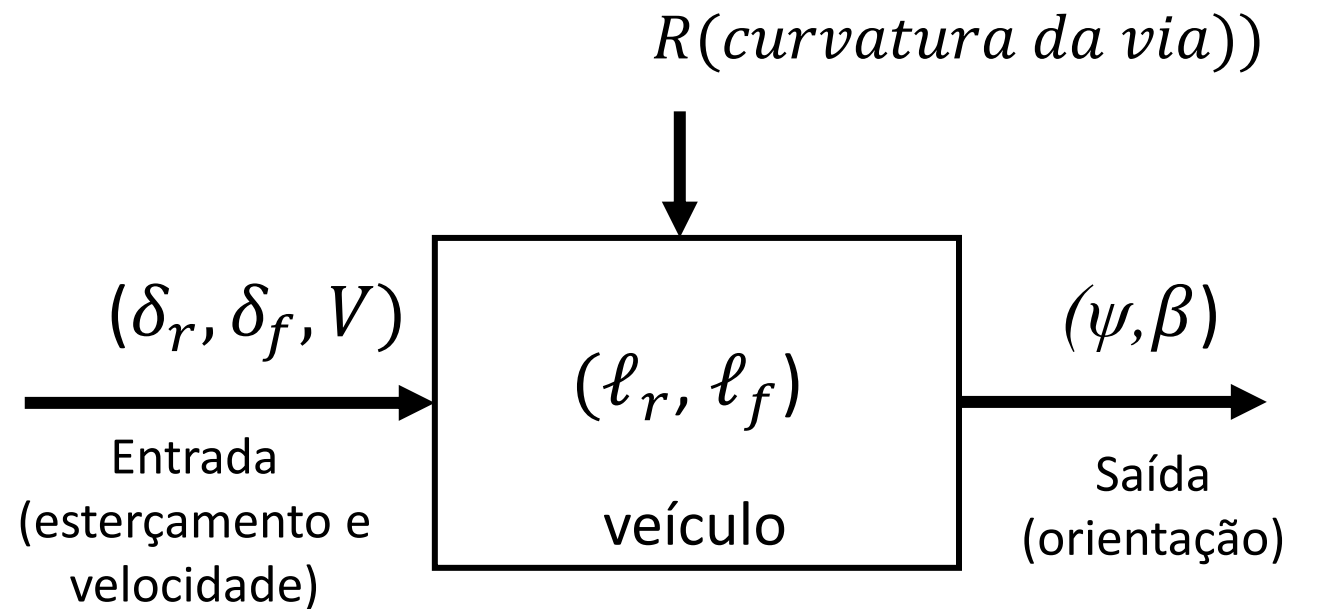
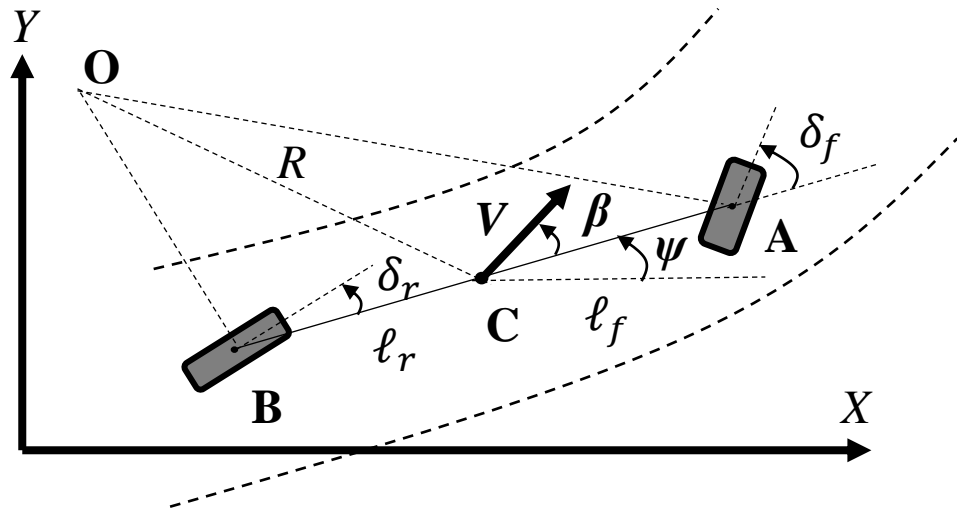
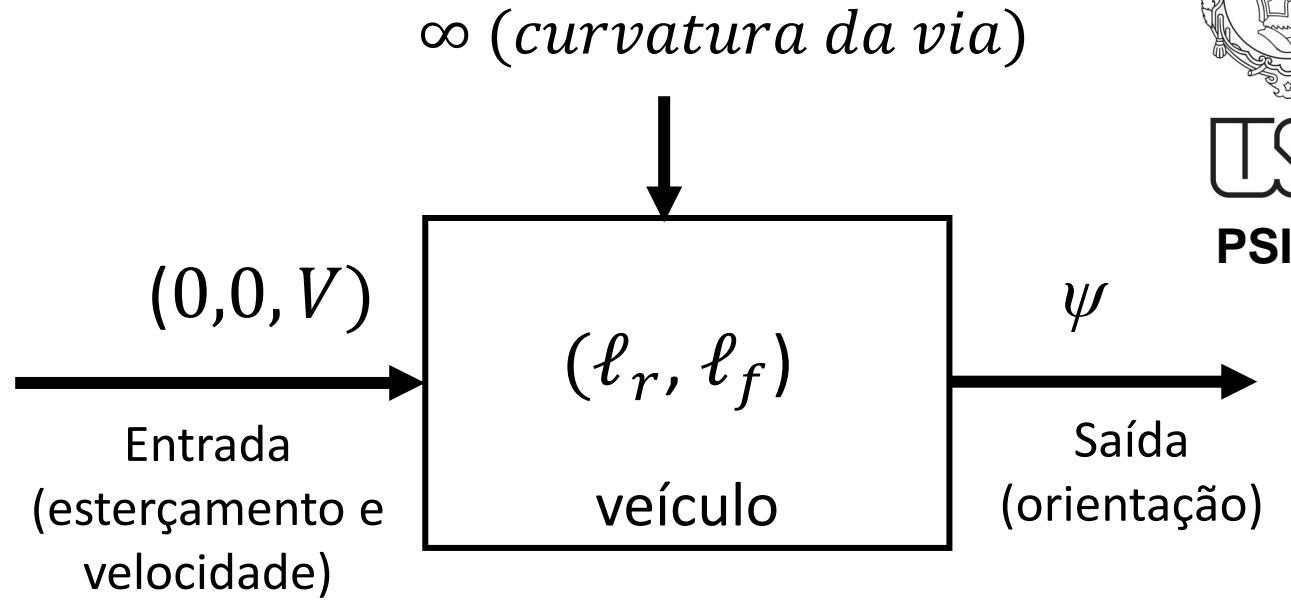
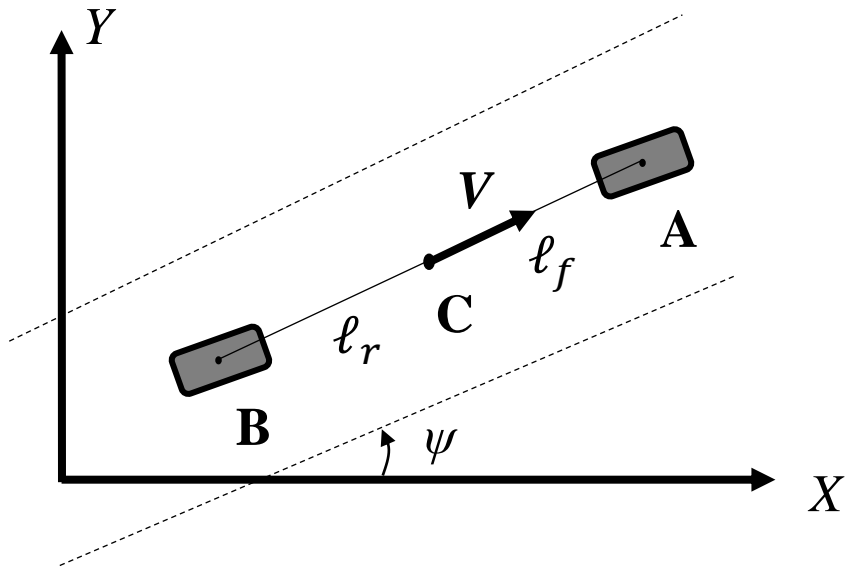



USP

PSI5121

- No modelo bicicleta representamos as duas rodas direcionais, direito e esquerdo, por uma única roda, assumindo que a o ângulo de esterçamento das duas rodas são aproximadamente iguais.
- Na prática já uma pequena diferença no ângulo de esterçamento entre a roda interna e externa numa curva.

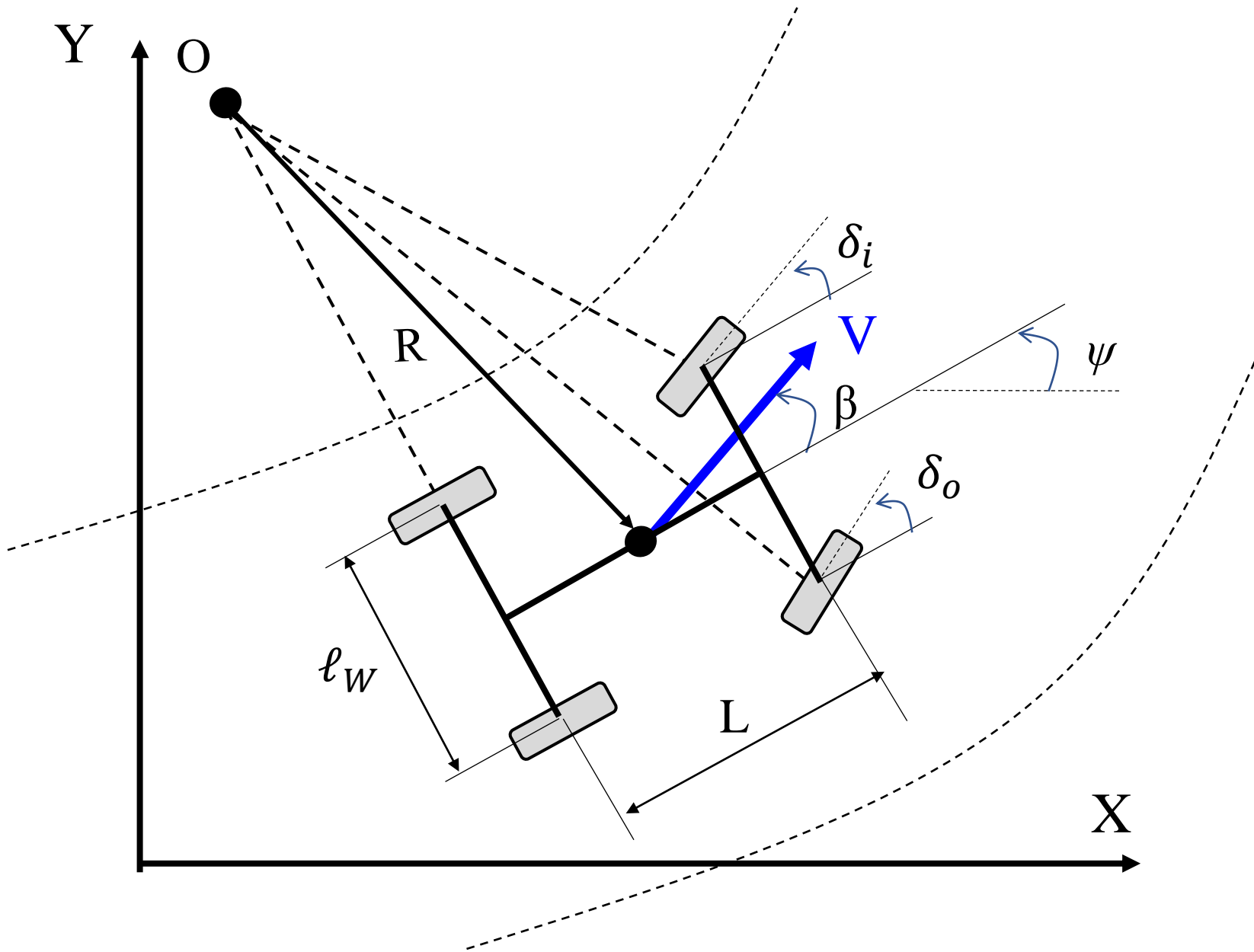

Vamos assumir que $L \ll R$
e β pequeno. Temos que:

$$\dot{\psi} \approx \frac{V}{R}$$

$$\frac{\dot{\psi}}{V} \approx \frac{1}{R} = \frac{\delta}{L}$$

$$\delta = \frac{\delta_o + \delta_i}{2} = \frac{L}{R}$$

$$\delta_i - \delta_o = \delta^2 \frac{l_W}{L}$$

Geometria de Ackerman – consiste num arranjo geométrico **trapezoidal** de ligações do sistema de direção de um carro, que resolve o problema da diferença de trajeto das rodas inferiores e exteriores num curva.



USP
PSI5121

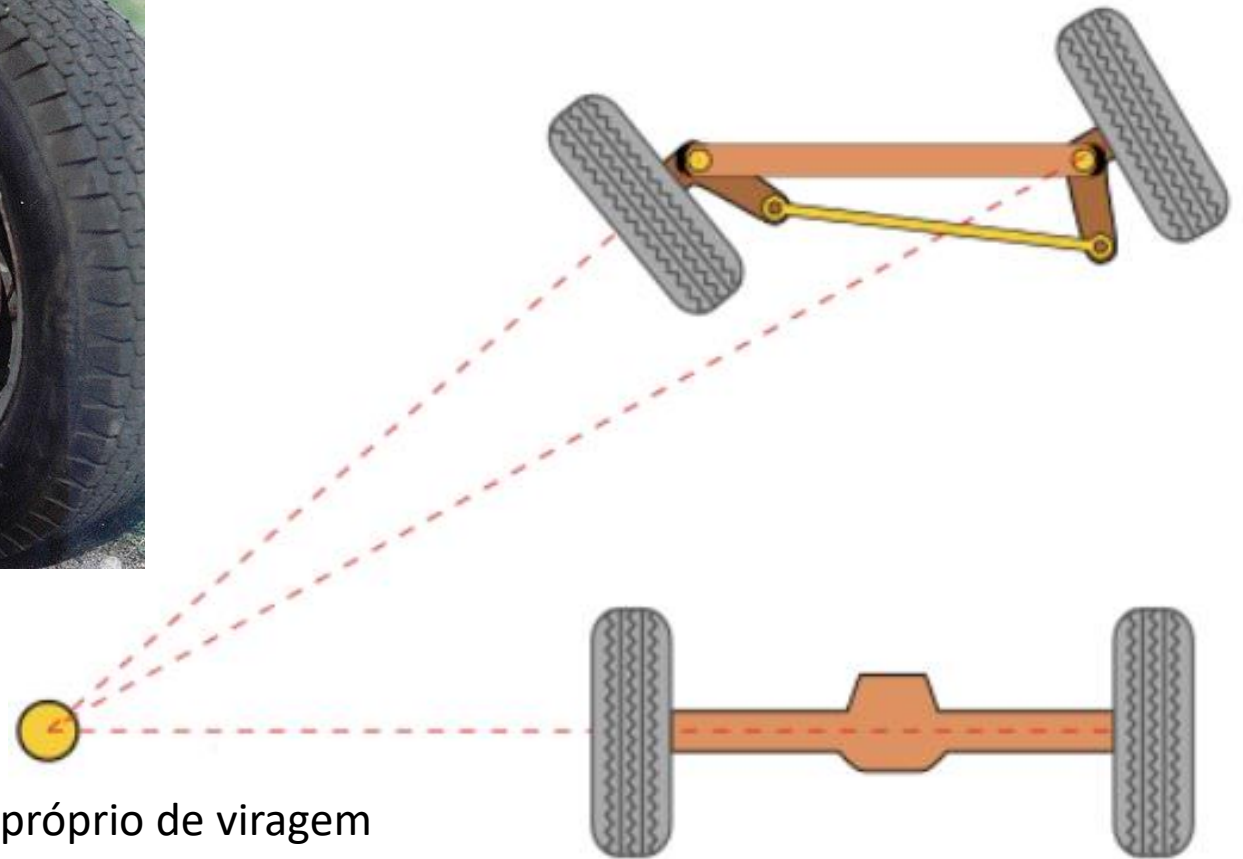
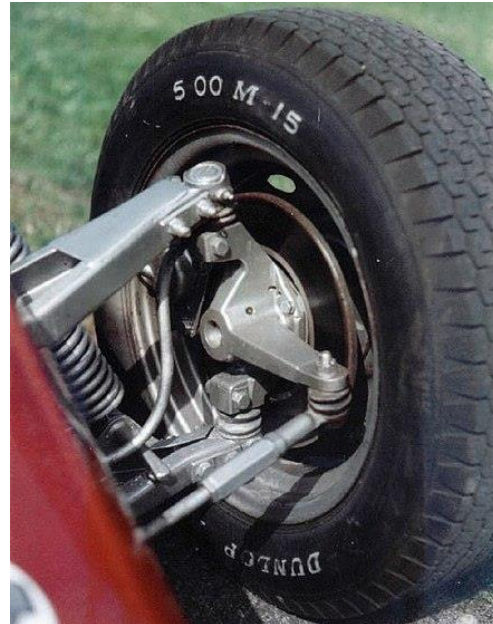
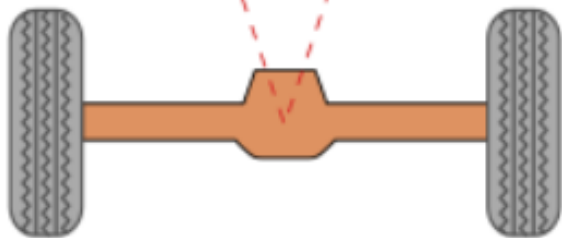

Centro próprio de viragem

Modelamento dinâmico do movimento lateral do veículo



USP
PSI5121

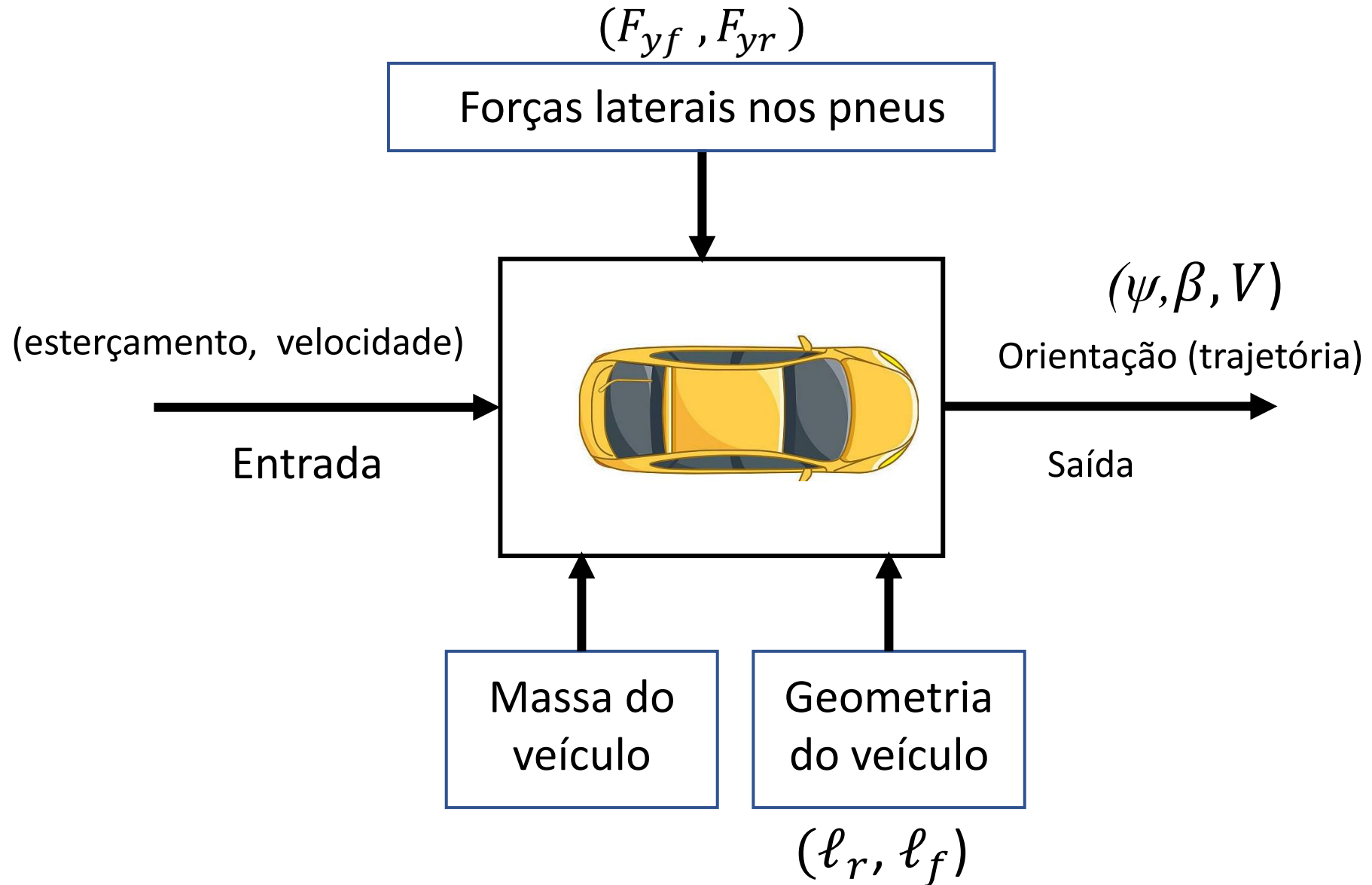

Modelamento dinâmico do movimento lateral do veículo



USP
PSI5121

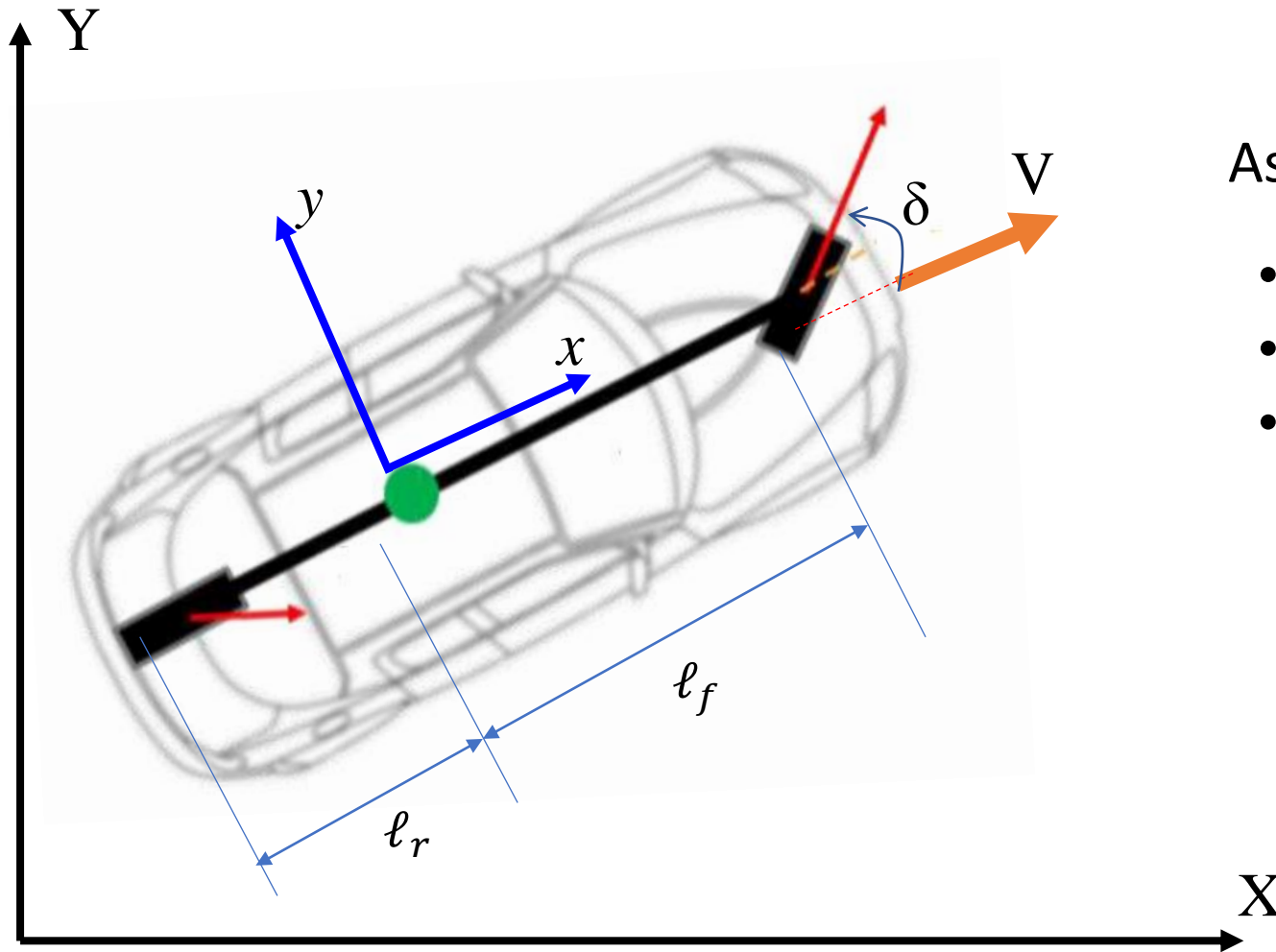

Assumiremos que:

- Velocidade longitudinal é constante
- Modelo bicicleta
- Movimentos da suspensão, inclinação da via e influencias aerodinâmicas não serão considerados

Dinâmica lateral

As equações que descrevem a dinâmica lateral do veículo são as seguintes:



USP

PSI5121

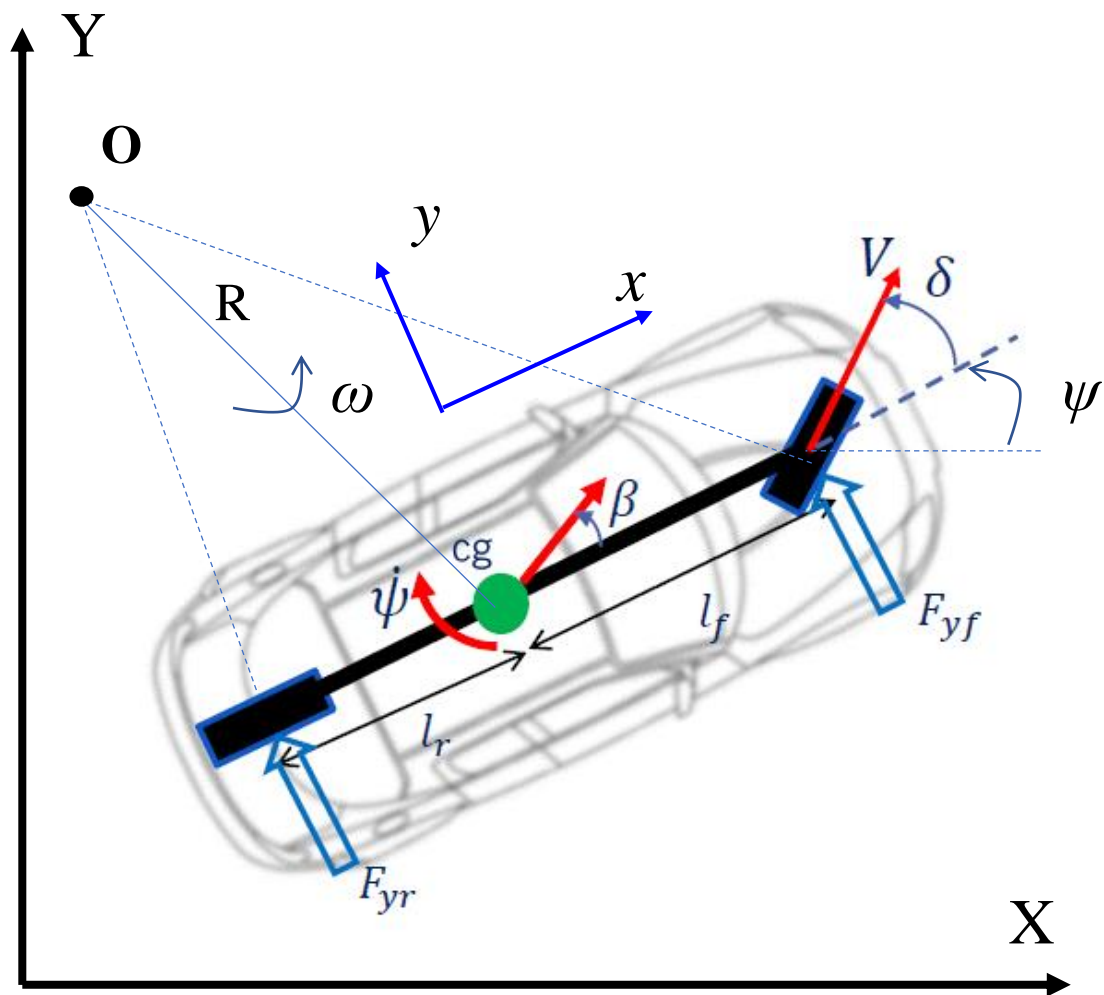

$$a_y = \ddot{y} + \omega^2 R = V(\dot{\beta} + \dot{\psi}) \quad : \text{aceleração lateral}$$

$$mV(\dot{\beta} + \dot{\psi}) = F_{yf} + F_{yr} \quad : \text{forças laterais}$$

$$I_z \ddot{\psi} = l_f F_{yf} + l_r F_{yr} \quad : \text{inércia e torque}$$

m : massa do veículo

$\dot{\beta}$: taxa de guinada (*yaw rate*)

$\dot{\psi}$: taxa de



Ângulo de escorregamento do pneu

Na dinâmica veicular, o ângulo de escorregamento (*slip angle*) se refere ao ângulo entre a direção apontada pelo pneu e a direção em que realmente está se movimentando.

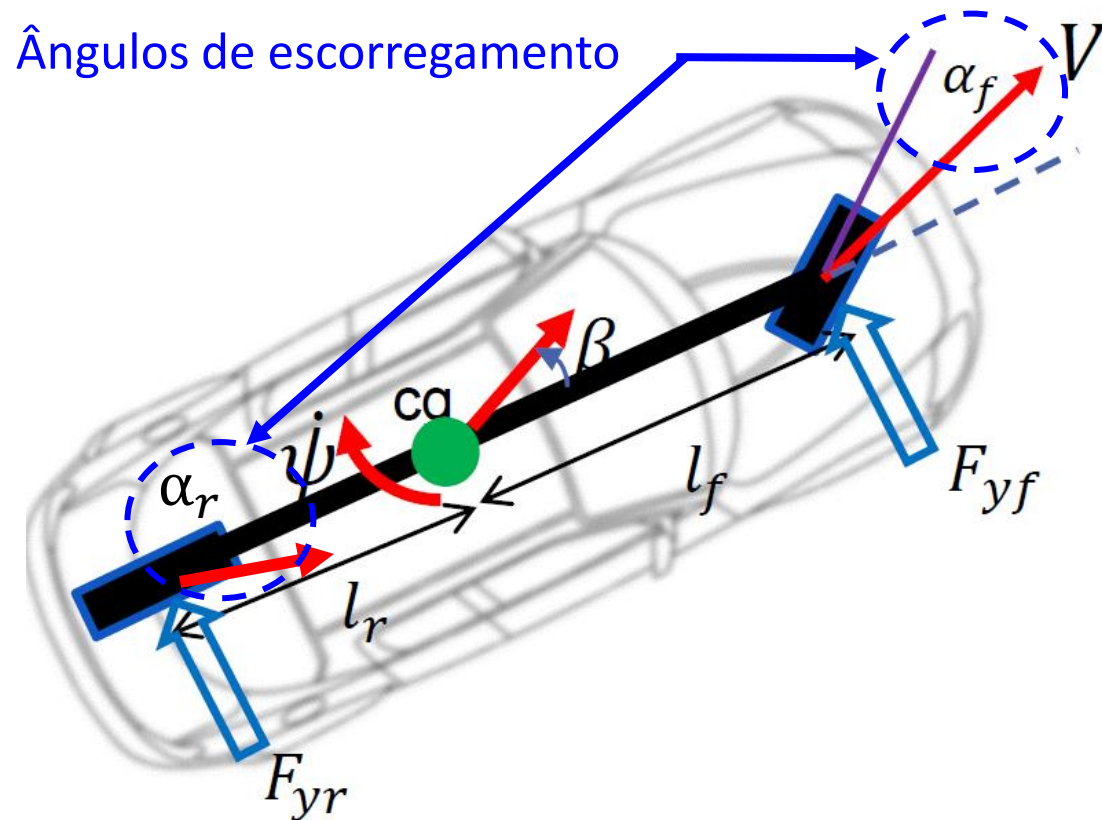

α_f : ângulo de escorregamento do pneu dianteiro

α_r : ângulo de escorregamento do pneu traseiro

Para ângulos de escorregamento pequeno a força lateral do pneu é aproximadamente um função linear do ângulo de escorregamento



USP

PSI5121

Forças laterais nos pneus dianteiro e traseiro

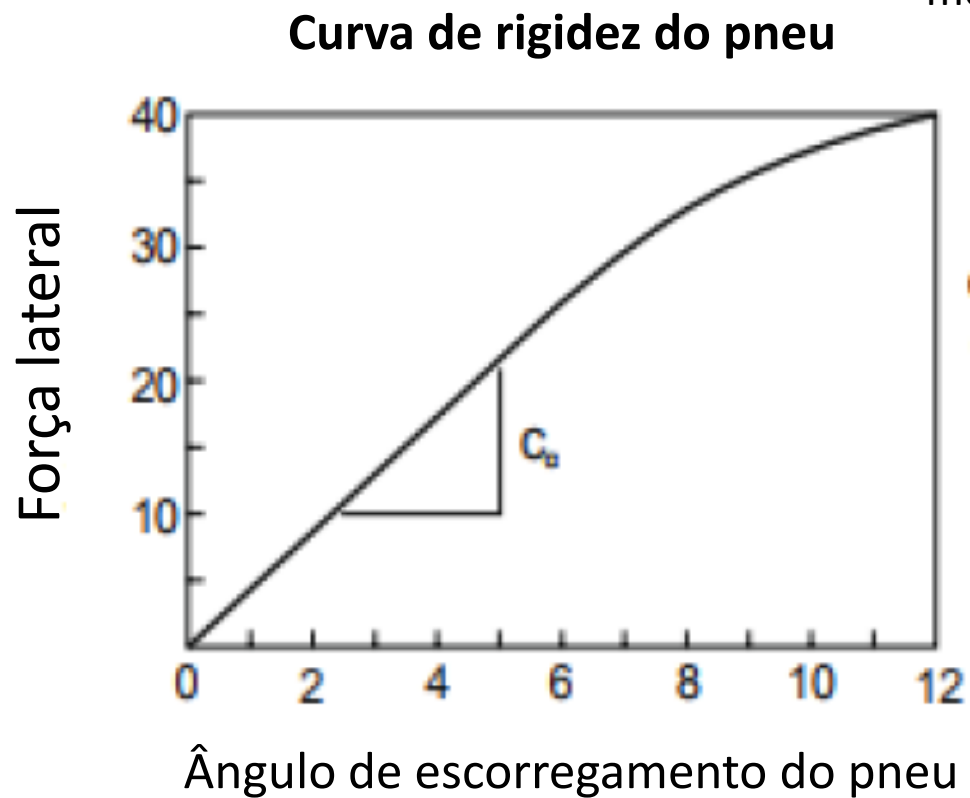

Direção do movimento

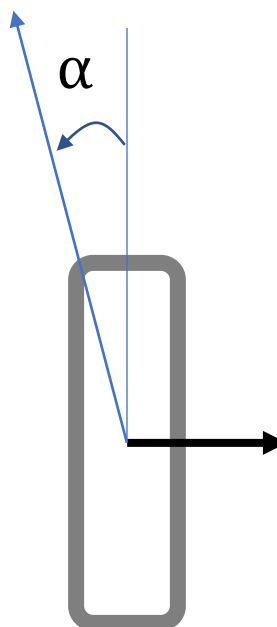

$$F_{yf} = C_f \alpha_f = C_f \left(\delta - \beta - \frac{\ell_f \dot{\psi}}{V} \right)$$

$$F_{yr} = C_r \alpha_r = C_r \left(-\beta + \frac{\ell_r \dot{\psi}}{V} \right)$$

C_f : coeficiente de rigidez pneu dianteiro

C_r : coeficiente de rigidez pneu traseiro



Dinâmica Lateral e de Guinada (*yaw*)

Equações dinâmica lateral :

$$mV(\dot{\beta} + \dot{\psi}) = F_{yf} + F_{yr}$$

$$I_z \ddot{\psi} = \ell_f F_{yf} + \ell_r F_{yr}$$

Equações forças laterais:

$$F_{yf} = C_f \alpha_f = C_f \left(\delta - \beta - \frac{\ell_f \dot{\psi}}{V} \right)$$

$$F_{yr} = C_r \alpha_r = C_r \left(-\beta + \frac{\ell_r \dot{\psi}}{V} \right)$$

$$\dot{\beta} = \frac{-(C_r + C_f)}{mV} \beta + \left(\frac{C_r \ell_r - C_f \ell_f}{mV^2} - 1 \right) \dot{\psi} + \frac{C_f}{mV} \delta$$

$$\dot{\psi} = \frac{C_r \ell_r - C_f \ell_f}{I_z} \beta - \frac{C_r \ell_r^2 + C_f \ell_f^2}{I_z V} \dot{\psi} + \frac{C_f \ell_f}{I_z} \delta$$



USP

PSI5121

Representação da dinâmica lateral no Espaço de Estados

Vetor de Estado: $\mathbf{X}_{lat} = [y \ \beta \ \psi \ \dot{\psi}]^T = \mathbf{A}_{lat}\mathbf{X}_{lat} + \mathbf{B}_{lat}\delta$

$$\mathbf{A}_{lat} = \begin{bmatrix} 0 & V & V & 0 \\ 0 & \frac{-(C_r + C_f)}{mV} & 0 & \left(\frac{C_r \ell_r - C_f \ell_f}{mV^2} - 1 \right) \\ 0 & 0 & 0 & 1 \\ 0 & \frac{C_r \ell_r - C_f \ell_f}{I_z} & 0 & \left(\frac{C_r \ell_r - C_f \ell_f}{mV^2} - 1 \right) \end{bmatrix} \quad \mathbf{B}_{lat} = \begin{bmatrix} 0 \\ \frac{C_f}{mV} \\ 0 \\ \frac{C_f \ell_f}{I_z} \end{bmatrix}$$



Modelo da dinâmica longitudinal do veículo

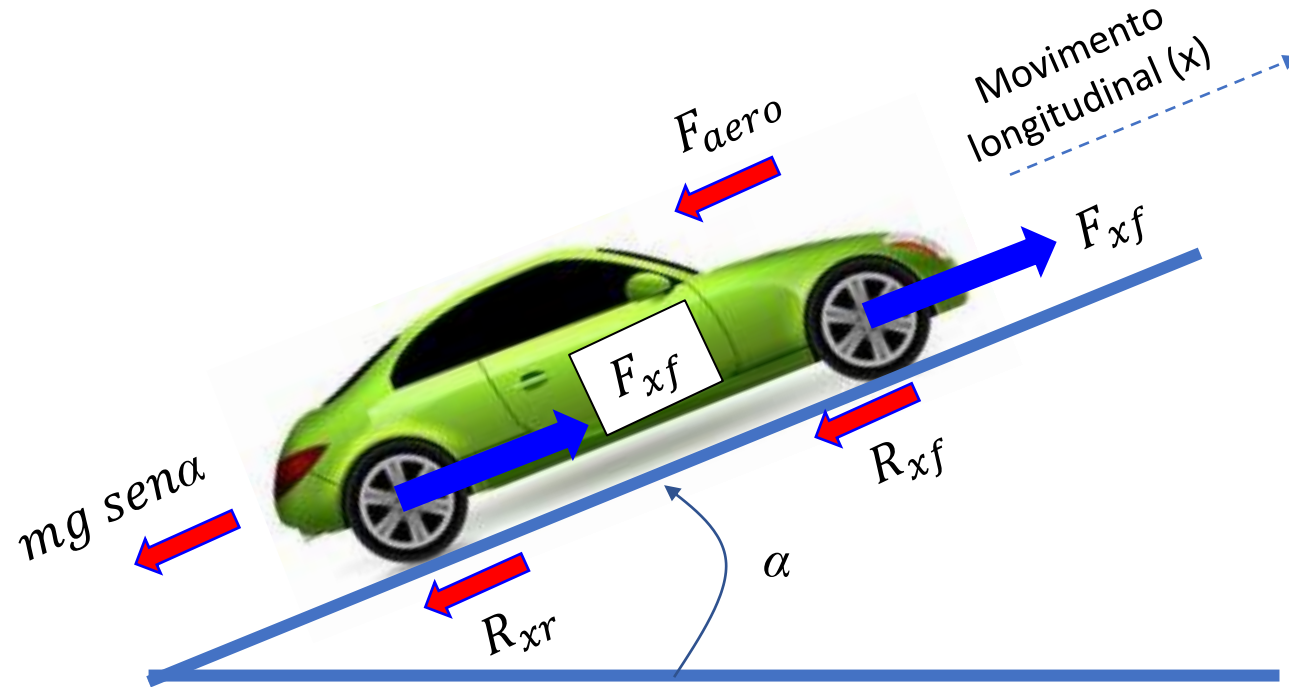

$$m\ddot{x} = F_{xf} + F_{xr} - F_{aero} - R_{xf} - R_{xr} - mg \text{ sen}\alpha$$

Acção do veículo

Força de tração dos pneus dianteiro e traseiros

Forças aerodinâmicas

Resistência de rolamento dos pneus dianteiros e traseiros

Força gravitacional devido à inclinação da via



Modelo longitudinal simplificado

Modelo longitudinal completo:

$$m\ddot{x} = F_{xf} + F_{xr} - F_{aero} - R_{xf} - R_{xr} - mg \operatorname{sen}\alpha$$

- Chamando de F_x a força longitudinal total:

$$F_x = F_{xf} + F_{xr}$$

- R_x a resistência rolamento total:

$$R_x = R_{xf} + R_{xr}$$

- Assumindo que α é pequeno:

$$\operatorname{sen}\alpha = \alpha$$

Resulta:

$$m\ddot{x} = \underbrace{F_x}_{\text{Força de tração}} + \underbrace{-F_{aero} - R_x - mg\alpha}_{\text{Força total de resistência } (F_{carga})}$$

Termo inercial



Modelo longitudinal simplificado

- Resistência de carga total:

$$F_{carga} = F_{aero} + R_x + m g \alpha = c_a \dot{x}^2 + c_r |\dot{x}| + m g \alpha$$

- A **resistência aerodinâmica** depende da densidade do ar, área frontal e a velocidade do veículo:

$$F_{aero} = \frac{1}{2} C_a \rho A \dot{x}^2 = c_a \dot{x}^2$$

- A **resistência de rolamento** depende força normal do pneu, pressão do pneu e a velocidade do veículo:

$$R_x \approx c_r |\dot{x}|$$

Trajectoria
desejada



Velocidade
desejada

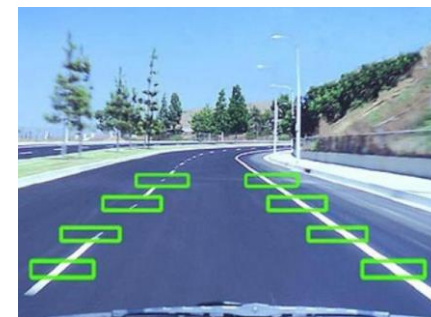

Modelo de controle lateral e longitudinal do veículo



USP
PSI5121

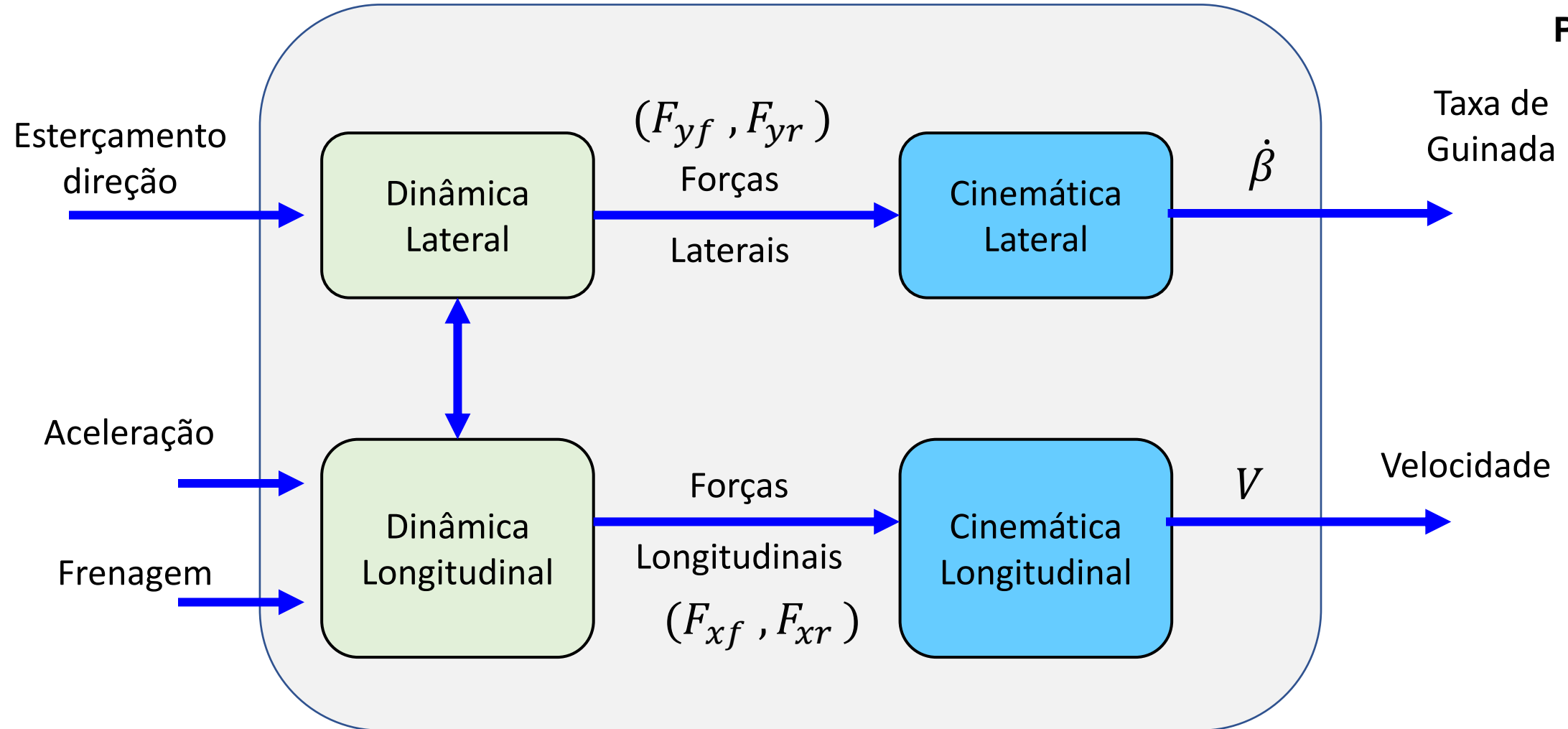



USP

PSI5121

Sistema de direção

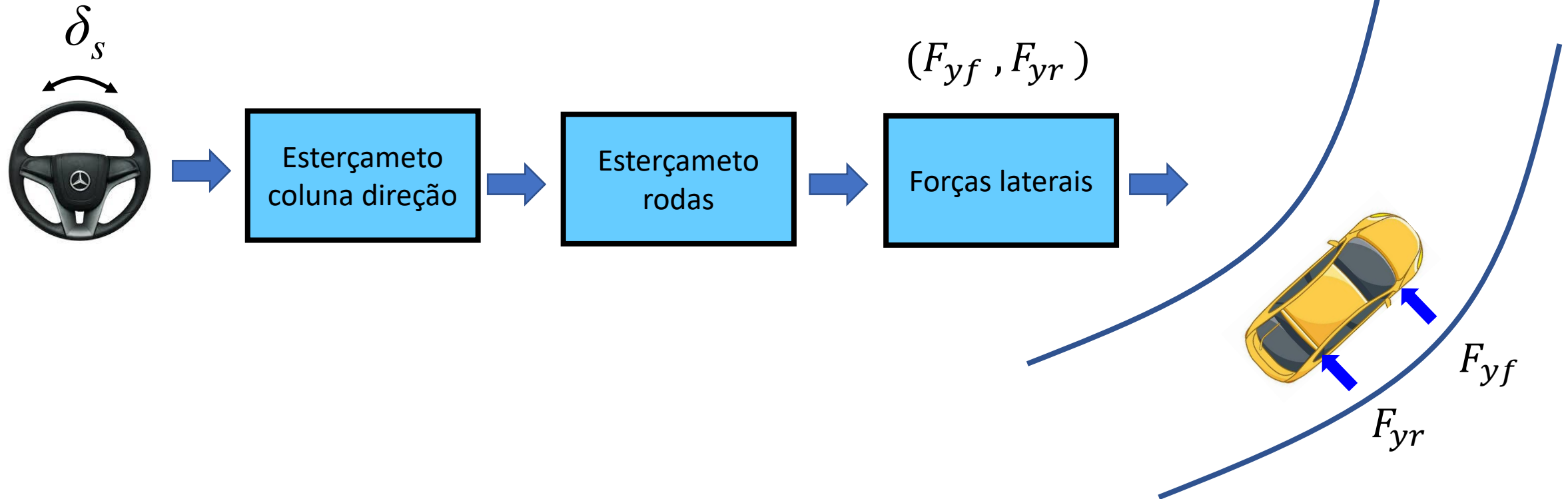



Modelo simples do sistema de direção

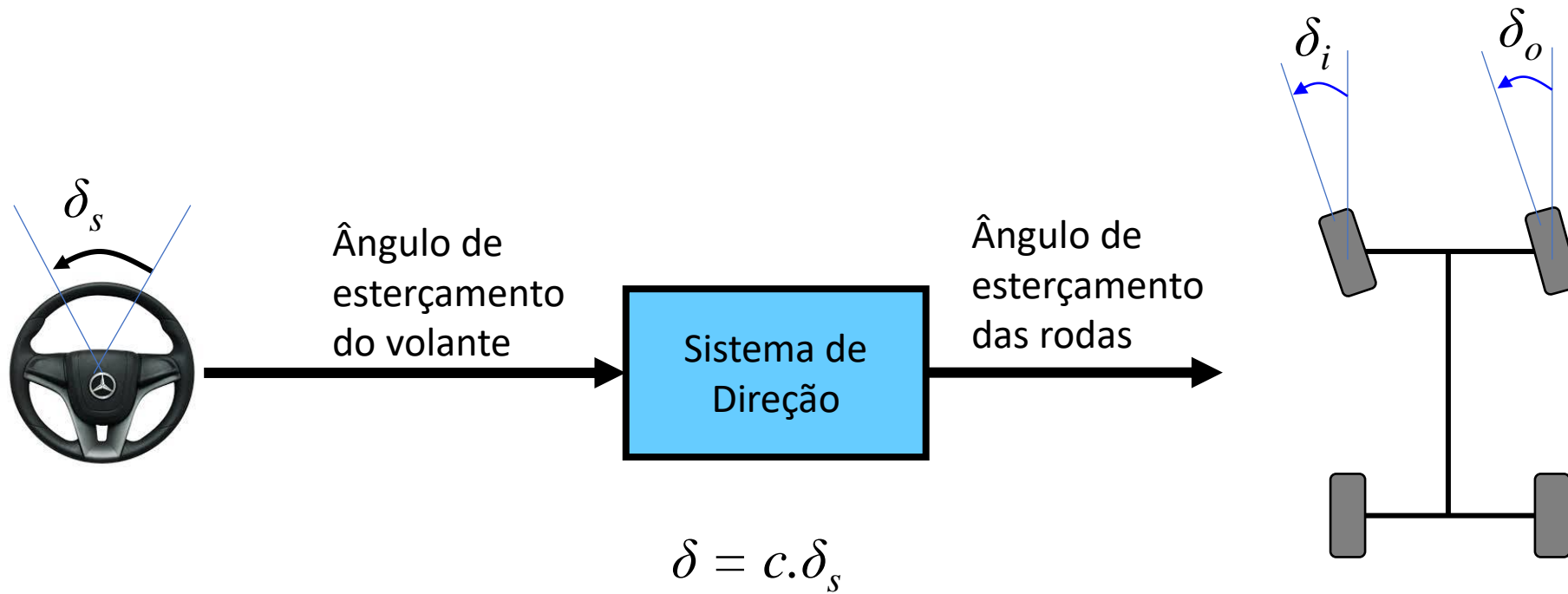



Sistema de direção elétrica

Esterçamento do volante

δ_s



Exemplo: sistema de direção elétrica da ZF



USP
PSI5121

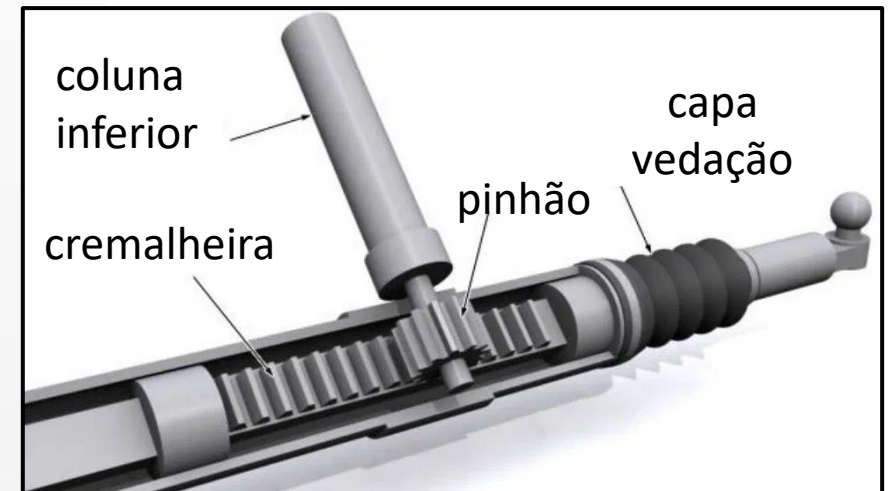
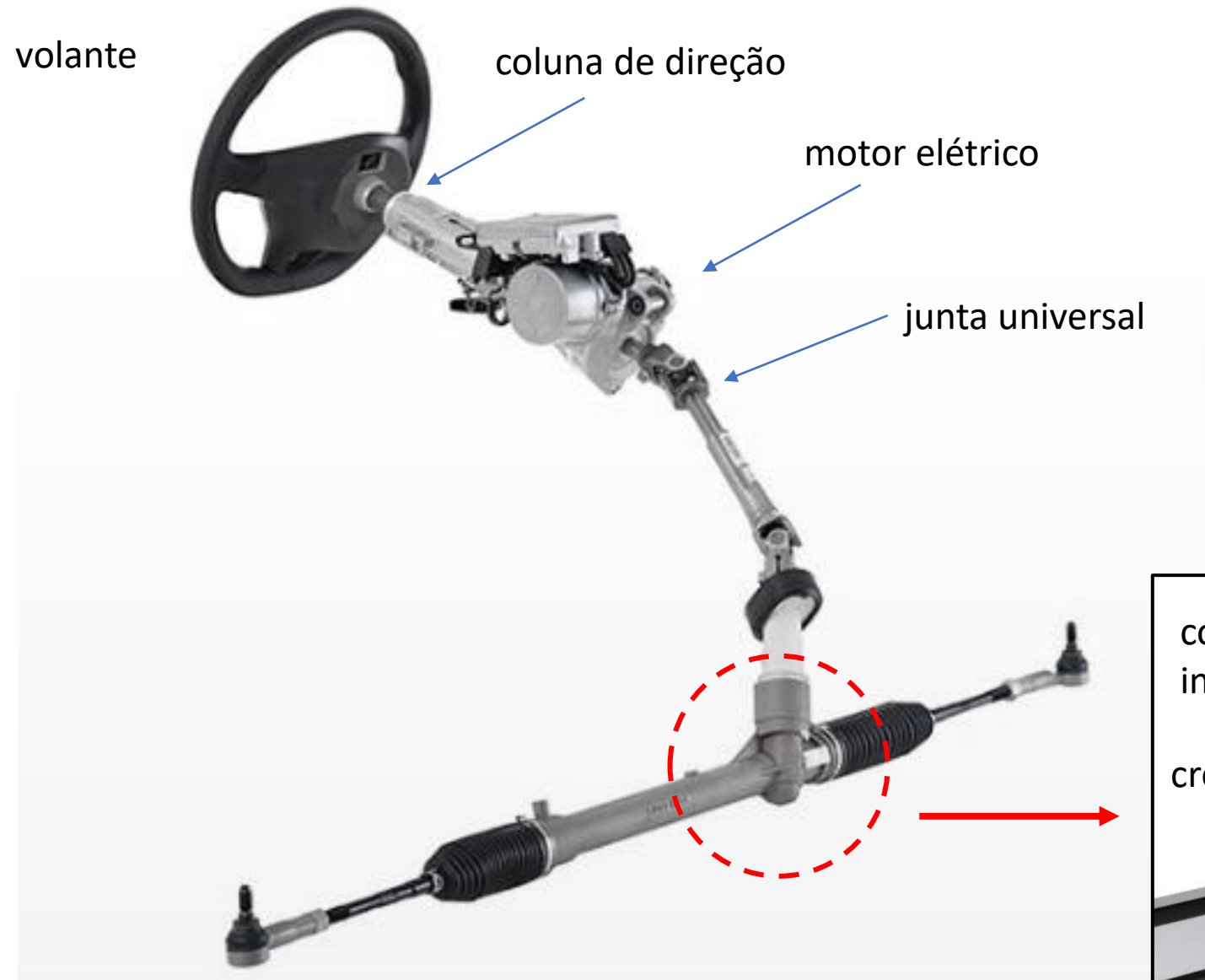



Sistema de tração (*powertrain*)

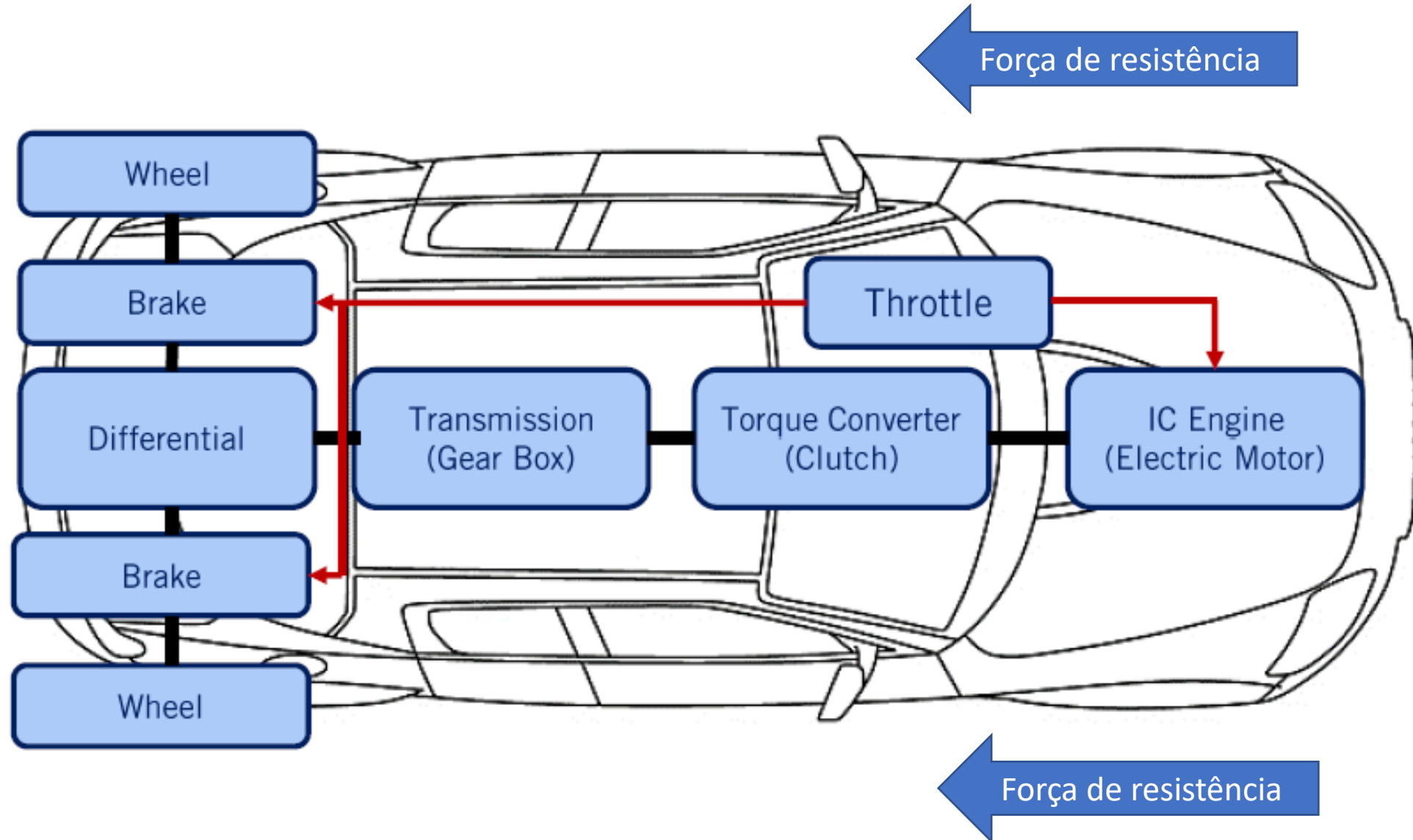

Aceleração (*throttling*)

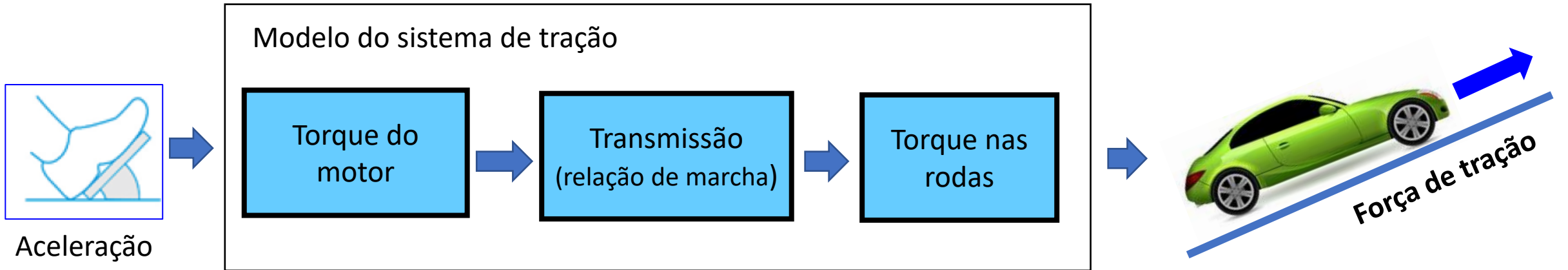



USP

PSI5121

Modelo do sistema de aceleração

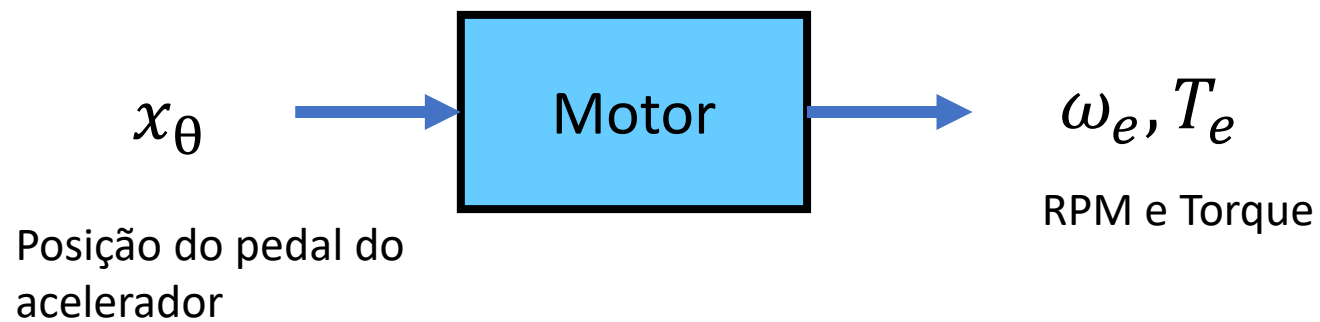

Característica de Torque vs Rotação



USP

PSI5121

Motor a gasolina

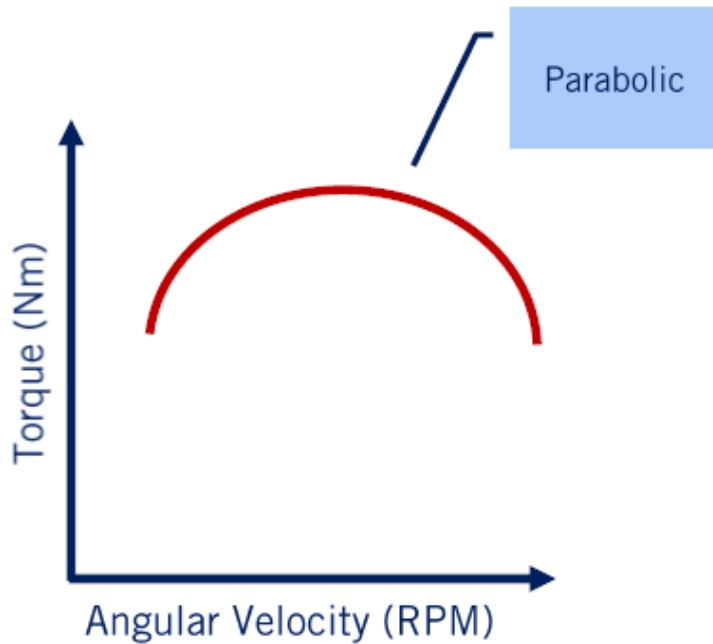

Motor diesel

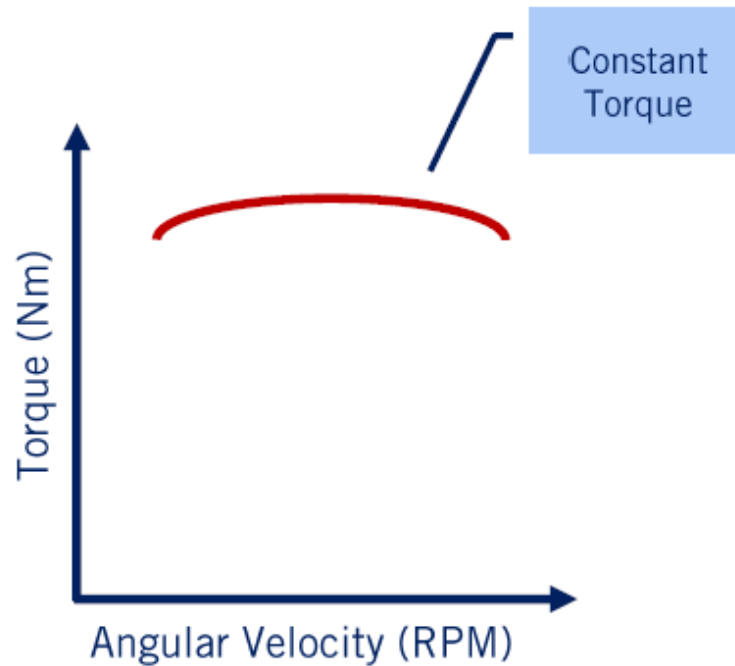

Motor elétrico

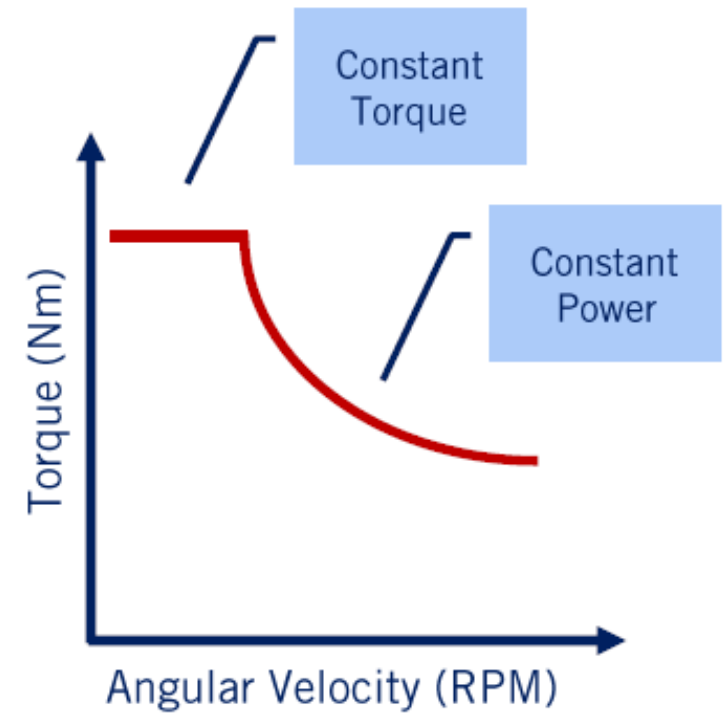



Curvas típicas de torque para motor à gasolina

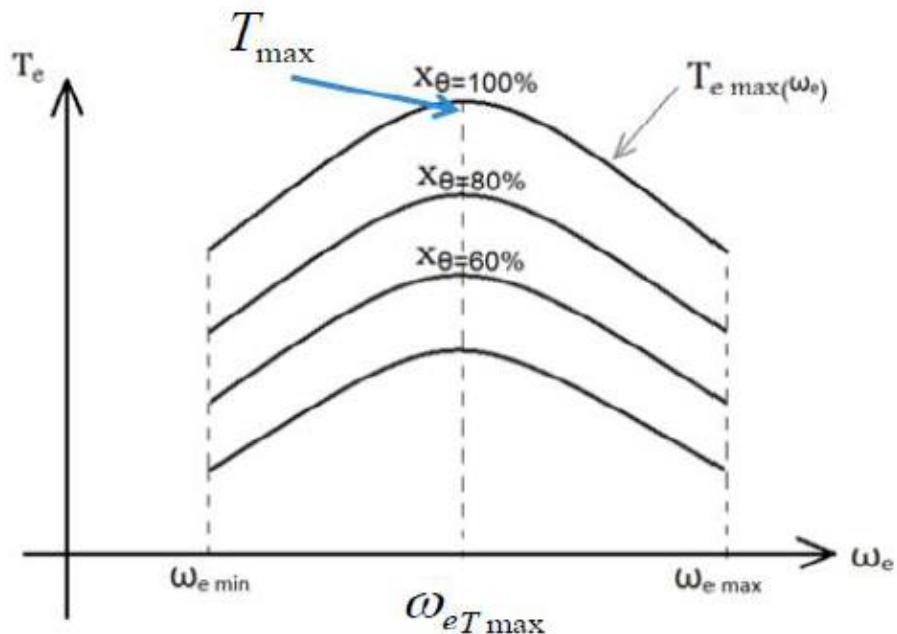

Curva de potência e torque do motor

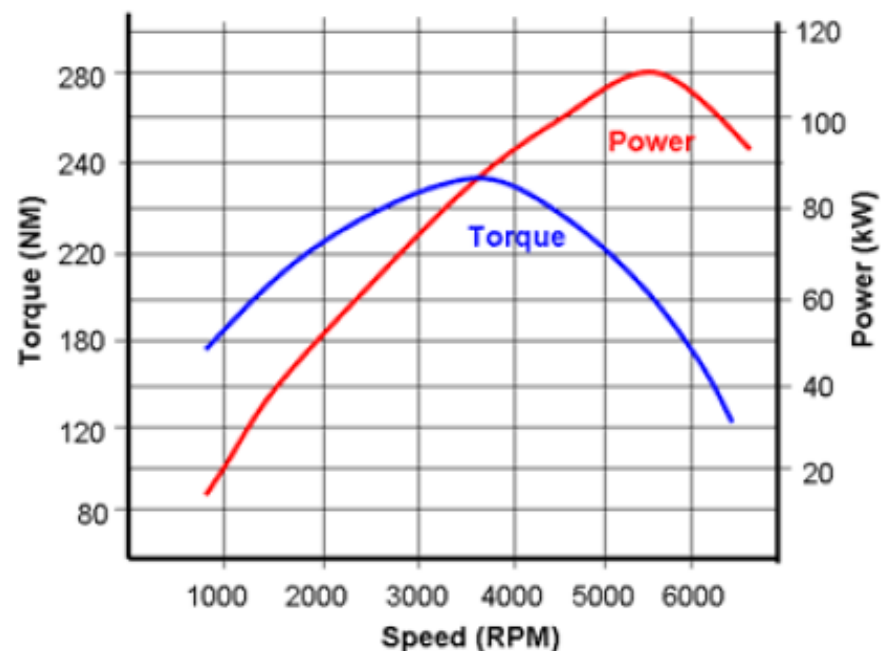

$$T_{e_{max}}(\omega_e) = A_0 + A_1\omega_e + A_2\omega_e^2$$

$$T_e(\omega_e, x_\theta) \approx x_\theta(A_0 + A_1\omega_e + A_2\omega_e^2)$$

Posição do pedal do
acelerador (%)

Frenagem (desaceleração)



USP
PSI5121



Frenagem

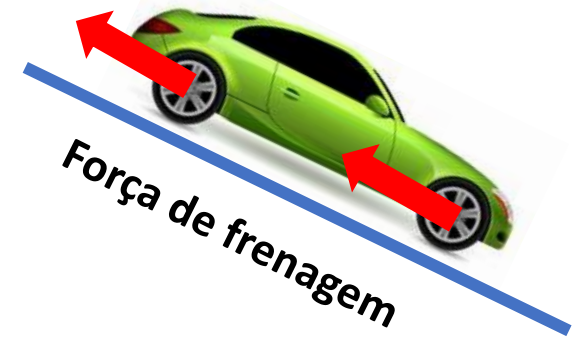
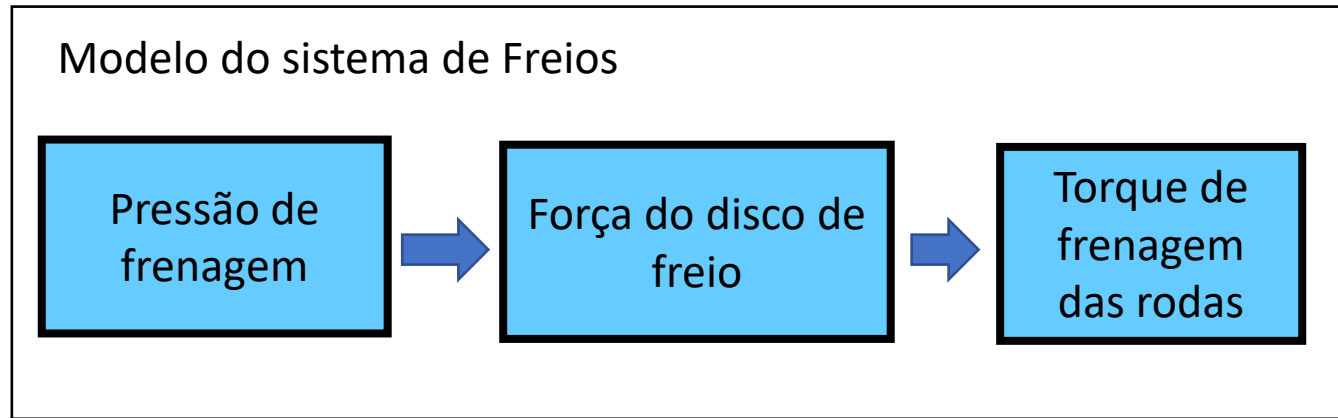

Modelo do sistema de Freios



USP
PSI5121

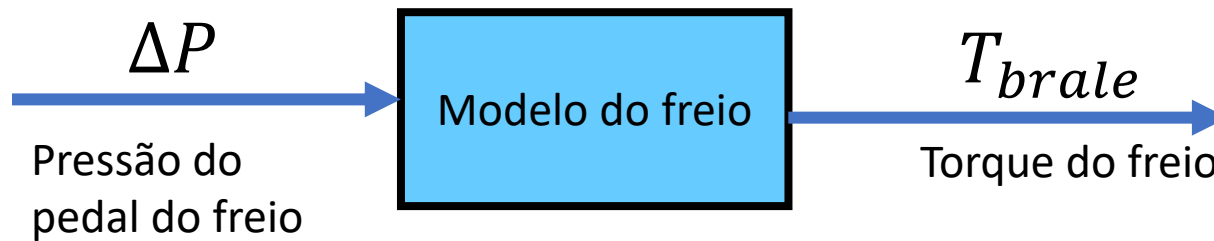
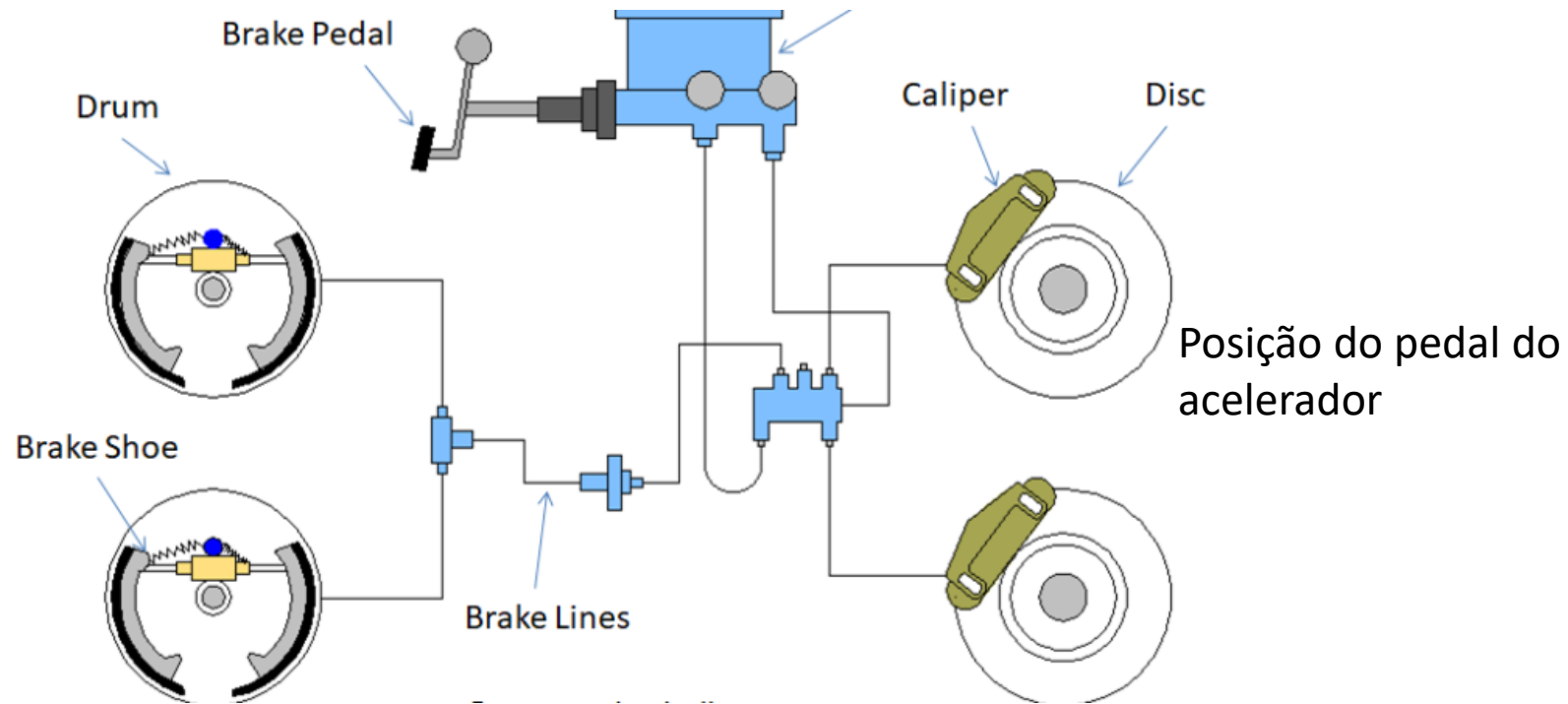

$$T_{brake} = k \cdot \Delta P$$

Sistema de Freios

Deve garantir:

- Reduzida distância para parar
- Dirigibilidade durante a frenagem por meio do sistema ABS
- Estabilidade durante a frenagem para evitar tombamento



USP
PSI5121

Modelo dinâmico do veículo em 2D



USP
PSI5121



Powertrain Modeling

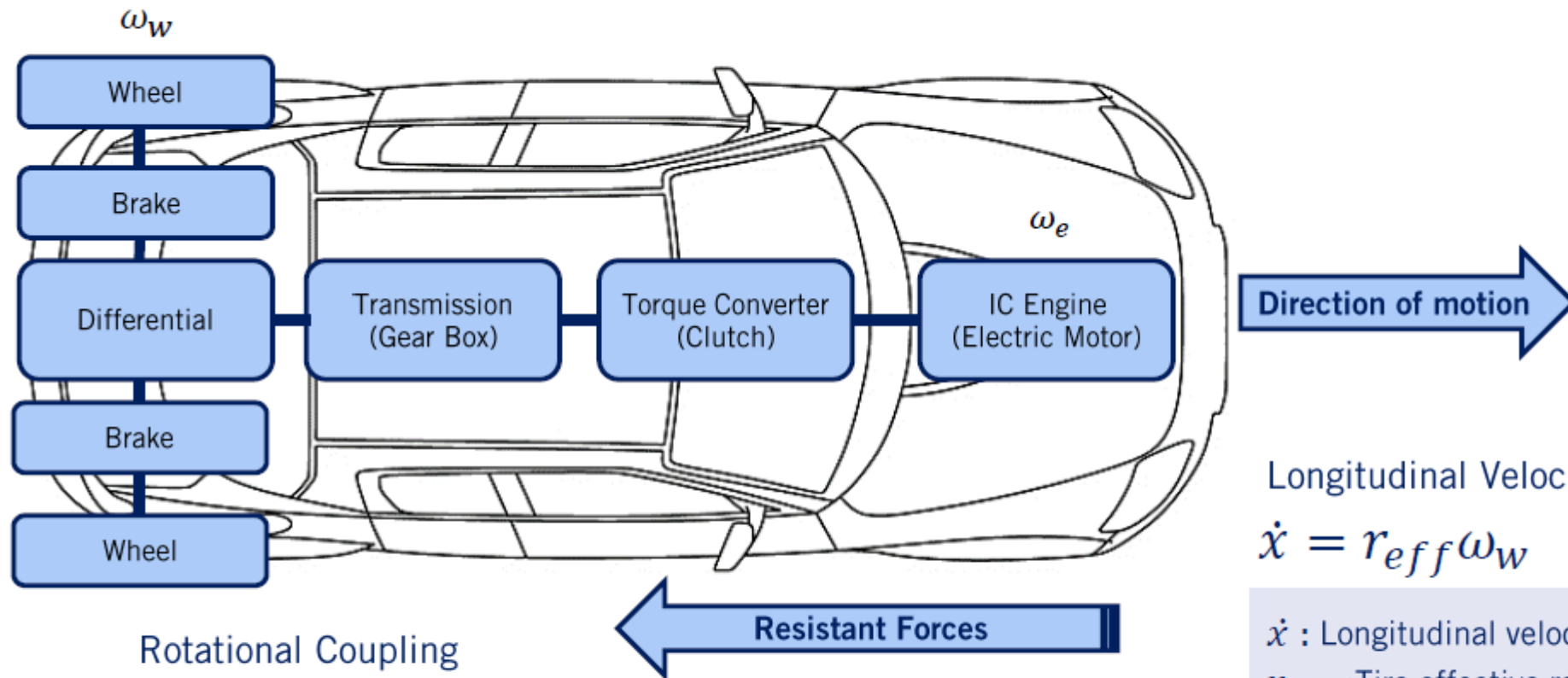

Rotational Coupling

$$\omega_w = GR\omega_t = GR\omega_e$$

ω_w :wheel angular speed
 ω_t :turbine angular speed
 ω_e :engine angular speed
 GR : Combined gear ratios

Longitudinal Velocity

$$\dot{x} = r_{eff}\omega_w$$

\dot{x} : Longitudinal velocity
 r_{eff} :Tire effective radius

Longitudinal acceleration

$$\ddot{x} = r_{eff}GR\dot{\omega}_e$$

Coupled Lateral & Longitudinal



USP
PSI5121

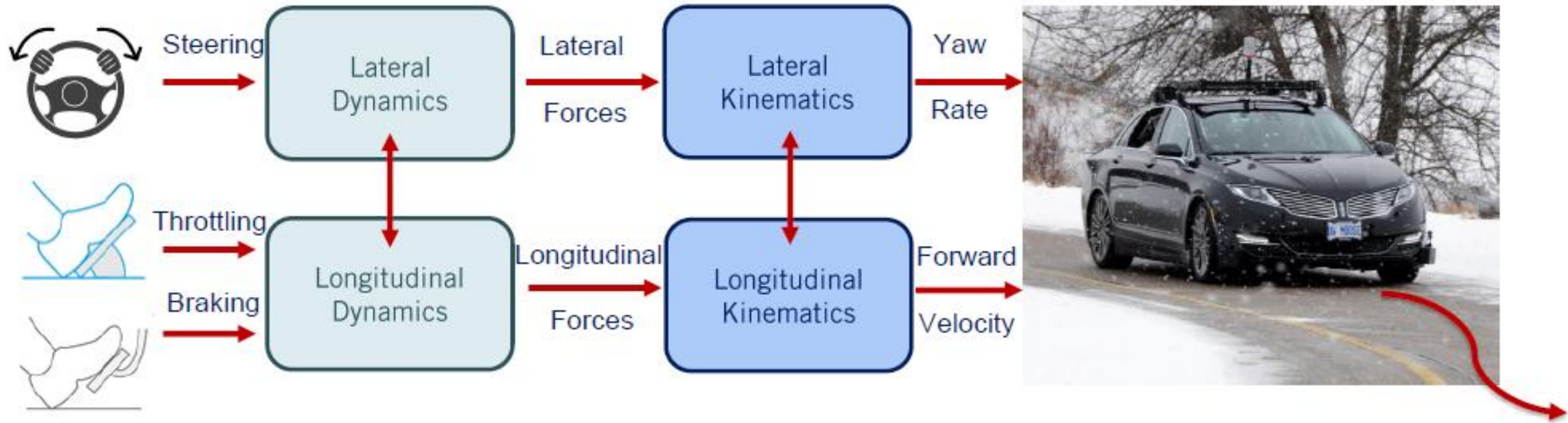

Objetivo do controle:

- manter o veículo na trajetória na velocidade desejada.