

Gravity and Magnetic Exploration

Principles, Practices, and Applications

WILLIAM J. HINZE, RALPH R. B. VON FRESE
and AFIF H. SAAD

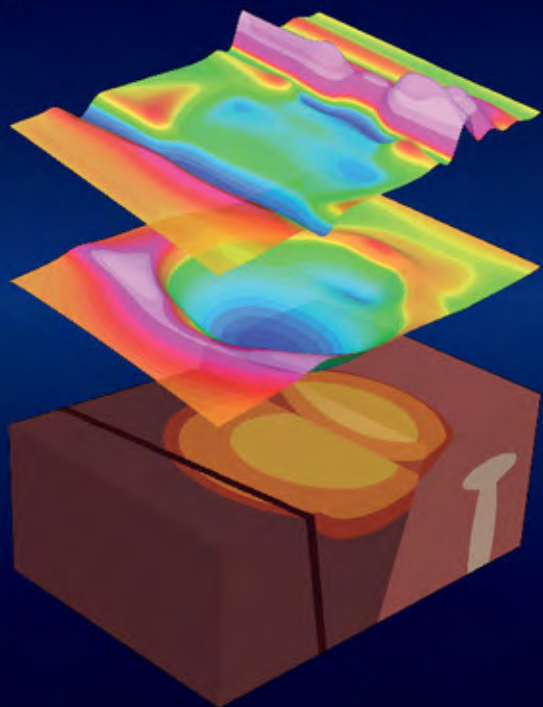

CAMBRIDGE

Gravity and Magnetic Exploration

Principles, Practices, and Applications

This combined study and reference text provides a comprehensive account of the principles, practices, and application of gravity and magnetic methods for exploring the subsurface using surface, subsurface, marine, airborne, and satellite measurements. Key current topics and techniques are described, including high-resolution magnetic investigations, time-variation gravity analysis from surface and satellite gravity measurements, absolute and gradient gravimetry, and the role of GPS in mapping gravity and magnetic fields. The book also describes the physical properties of rocks and other Earth materials that are critical to the effective design, implementation, and interpretation of surveys, and presents an overview of digital data analysis methods used to process and interpret anomalies for subsurface information.

Each chapter starts with a general overview and concludes with a list of key concepts that help readers review what they have learned. An appendix provides a grounding on basic data analysis using simple and accessible mathematical notation. Study questions and problem sets on an accompanying website, together with computer-based exercises available online, give readers hands-on experience of processing, modeling, and interpreting gravity and magnetic anomaly data. A comprehensive suite of full-color case histories on the book's website illustrates the practical utility of modern gravity and magnetic surveys in energy, mineral, environmental, archaeological, and engineering exploration and lithospheric studies, as well as their potential limitations.

This book is an ideal text for advanced undergraduate and graduate courses but also serves as a reference for research academics, professional geophysicists, and managers of exploration programs that use gravity and magnetic methods. It is a valuable resource for all those interested in petroleum, engineering, mineral, environmental, geological, and archaeological exploration of the lithosphere.

WILLIAM J. HINZE is Emeritus Professor of Geophysics at Purdue University, and has taught exploration geophysics for 40 years. His extensive teaching and research experience is complemented by industrial consulting experience in the geological and engineering applications of gravity and magnetic

fields. He has authored or co-authored more than 130 journal publications, and four books, and has served as Associate Editor of *Geophysics* and Senior Editor of *The Journal of Geophysical Research – Solid Earth*. Professor Hinze has been a member of numerous government and scientific panels dealing with key issues from the geophysics and geology of continents to nuclear waste disposal and geophysical data. He is a member of the Society of Exploration Geophysicists, the American Geophysical Union, and the Geological Society of America.

RALPH R. B. VON FRESE is Professor of Earth Sciences at The Ohio State University, where he has taught undergraduate and graduate courses across geophysics and Earth systems since 1982. His research has focused mostly on archaeological and planetary applications of gravity and magnetic fields, and he has authored or co-authored more than 100 journal publications and served on several government and scientific panels. Professor von Frese is the founding co-chair of the Antarctic Digital Magnetic Anomaly Project (ADMAP), an international collaboration of the Scientific Committee for Antarctic Research (SCAR) and the International Association of Geomagnetism and Aeronomy (IAGA). He is a member of the Society of Exploration Geophysicists, the American Geophysical Union, and the Geological Society of America.

AFIF H. SAAD is a Geophysical Consultant to the oil and gas exploration industry, specializing in integrated interpretation, modeling, magnetic depth estimation, software development, and training. He has over 40 years of broad experience in the theory and practice of gravity and magnetic methods in exploration, including 25 years in the oil industry, and has provided training at several schools and workshops in basic, intermediate, and advanced gravity and magnetics in the United States and overseas. Dr Saad has authored or co-authored several publications, has peer-reviewed numerous papers and textbooks in gravity and magnetics for *Geophysics* and the *Geophysical Journal International*, and has served as Associate Editor for *Magnetic Exploration Methods for Geophysics*. He is a member of the Society of Exploration Geophysicists (SEG), the SEG Gravity and Magnetism Committee, the SEG Global Affairs Committee, and the Geophysical Society of Houston.

“Written by three leading researchers, this is a comprehensive textbook that takes its readers from the fundamentals of potential fields through modern data acquisition, processing, modeling and inversion to practical interpretation. The theory and mathematical derivations are suitable for both beginners and experienced geophysicists. Well-organized and nicely illustrated, it is both informative and clearly written.”

– **Professor Dr Alan Green**

Institute of Geophysics, ETH-Swiss Federal Institute of Technology

“This extensive work is much more than just a textbook: it includes detailed discussions, such as the philosophy of modeling and the nature of errors, which are critical to properly interpreting gravity and magnetic data, but are often glossed over. A very useful addition to practitioners’ reference shelves and an excellent textbook for advanced students.”

– **Roger C. Searle, Professor Emeritus**

Department of Earth Sciences, Durham University

“The geophysical applications of gravity and magnetic techniques have advanced a great deal in the twenty-first century. Thus, this rigorous book covering the physical basis, analysis, interpretation, and applications of these techniques is a timely and important contribution. It is designed to serve both the student and practitioner and is enhanced by an innovative website.”

– **Professor G. Randy Keller**

Geology and Geophysics, University of Oklahoma;

Director of Oklahoma Geological Survey

Gravity and Magnetic Exploration

Principles, Practices, and Applications

William J. Hinze

Purdue University

Ralph R. B. von Frese

The Ohio State University

Afif H. Saad

Saad GeoConsulting



CAMBRIDGE
UNIVERSITY PRESS

CAMBRIDGE UNIVERSITY PRESS

Cambridge, New York, Melbourne, Madrid, Cape Town,
Singapore, São Paulo, Delhi, Mexico City

Cambridge University Press
The Edinburgh Building, Cambridge CB2 8RU, UK

Published in the United States of America by Cambridge University Press, New York

www.cambridge.org

Information on this title: www.cambridge.org/9780521871013

© William J. Hinze, Ralph R. B. von Frese and Afif H. Saad 2013

This publication is in copyright. Subject to statutory exception
and to the provisions of relevant collective licensing agreements,
no reproduction of any part may take place without the written
permission of Cambridge University Press.

First published 2013

Printed and bound in the United Kingdom by the MPG Books Group

A catalog record for this publication is available from the British Library

ISBN 978-0-521-87101-3 Hardback

Additional resources for this publication at www.cambridge.org/gravmag

Cambridge University Press has no responsibility for the persistence or
accuracy of URLs for external or third-party internet websites referred
to in this publication, and does not guarantee that any content on such
websites is, or will remain, accurate or appropriate.

10 Magnetization of Earth materials

10.1 Overview

The magnetic method is based on variations in the magnetic field derived from lateral differences in the magnetization of the subsurface. As a result, an understanding of the magnetization of Earth materials, and the physical and geologic factors that control it, is essential in planning surveys as well as interpreting magnetic anomalies.

Magnetization consists of the vectorial addition of induced and remanent components. Induced magnetization depends on the magnetic susceptibility of the material and the magnitude and direction of the ambient magnetic field, while remanent magnetization reflects the past magnetic history of the material. This makes the prediction of the magnetization of Earth materials difficult in many geological situations. This problem is amplified because, unlike rock densities which vary by only a few orders of magnitude, magnetizations commonly have a range of 10^3 or more. The resulting uncertainty in estimating magnetization is made greater by the fact it is controlled by a few minerals that occur only as accessory constituents in essentially all Earth materials. As a result, material types do not have diagnostic magnetic properties, but useful generalizations can be made based on an understanding of the nature of the constituent magnetic minerals and the thermal and magnetic history of a specific geologic formation. Measurements of magnetic susceptibilities generally are made on samples using an induction balance, and remanent magnetism is determined by measuring the total effect on a magnetic sensor of rotating an oriented sample around three perpendicular axes.

10.2 Introduction

Knowledge of germane Earth material magnetizations within a study region is required for effective planning and implementation of magnetic surveys. Accordingly, as an important component to the magnetic method, this chapter describes the fundamentals of this property and the controls on it, together with methods of measuring it. Representative values are presented of the magnetization properties of a variety of Earth materials including igneous, metamorphic, and sedimentary rocks, sediments, and soils to aid the explorationist in the use of the magnetic method.

Magnetization is directionally dependent, consisting of the vectorial addition of induced and remanent components. Induced magnetization is a function of the magnetic

susceptibility of the materials (Section 10.5) and the magnitude and direction of the ambient magnetic field, whereas remanent magnetization reflects the history of the material. In practice, it is not the magnetization that is the controlling property of magnetic anomaly fields, but rather the magnetization contrast between the anomalous source and the laterally adjacent formations, the so-called country rocks, that are assumed to be constant and the norm. As a result, magnetization within a survey region involves both the anomalous volume and the country rock. The magnetization contrast of the anomaly source is said to be positive if the magnetization of the anomalous body exceeds that of the country rock and negative for the reverse.

Induced and remanent magnetization are difficult to estimate by visual inspection or by rock type identification

because magnetization is controlled by the previous thermal, chemical, and magnetic history of the material which may be poorly known at best. In addition, the magnetization of most rocks and sediments results from only a few minerals that occur as accessory constituents rather than as major minerals that are used to categorize rocks. Although there are numerous tabulations of magnetic properties, they are primarily focused on rocks that are of interest in mineral resource exploration, which are atypical of most Earth materials, and on measurements of remanent magnetization made for paleomagnetism studies. The latter are used to study the previous magnetic field of the Earth and indirectly a number of features of geological interest, but for the most part the magnitudes of measurements made for paleomagnetism purposes are below the threshold of interest in exploration applications.

The magnetic polarization of rocks and other Earth materials largely comes from the accessory mineral magnetite and varies in common rocks over a range of 10^3 or more. This is considerably larger than the range of densities in Earth materials. As a result, magnetic anomalies have a much larger dynamic range than gravity anomalies. Studies of well-logs, magnetic anomaly data, and geologic samples indicate that magnetization is scale-independent within the crust (e.g. PILKINGTON and TODOESCHUCK, 1995, 2004; TODOESCHUCK *et al.*, 1994) and show that there is a great deal of variation within formations. Remanent magnetization tends to be highly variable depending on the primary and secondary geological processes involved over the history of the rock. Generally, values are of the order of 0.1 to 1.0 times the induced magnetization, but much larger values are observed, especially in young, mafic volcanic rocks and some iron and steel objects. As a general rule, magnetization is not clearly diagnostic of most common rock types because of overlapping ranges and may be variable at a range of scales within a formation. This is especially true because magnetic properties are particularly prone to modification by secondary processes and the heterogeneous distribution of magnetite. As a result, accurately specifying properties by measurements on samples requires care, and use of magnetic property tabulations is problematic. In view of the latter concern, measurements of magnetic properties of samples from the local region are preferable in magnetic surveying, particularly if they are *in situ*. Unfortunately these are not easily made. Measurements of both magnetic susceptibility (which controls induced magnetization) and remanent magnetization require specialized instrumentation (see Section 10.7) and access to multiple samples. As a result, *in situ* measurements are not available for most investigations.

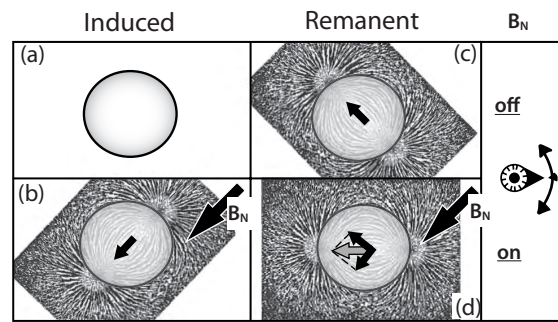

FIGURE 10.1 Matrix illustrating the magnetization set up when a magnetized body (a) is subjected to (b) an externally applied magnetic field \mathbf{B}_N . Note that the gray vector in (d) is the resultant magnetization of the induced (b) and remanent (c) components. Simulated iron filings illustrate the patterns of the related force fields.

10.3 Magnetism of Earth materials

Magnetic fields originate in the movement of electrical charges according to the laws of electromagnetism. Atoms, which consist of a positively charged nucleus encircled by shells of orbiting and spinning electrons, are thus a potential source of magnetism. If the individual magnetic moments of neighboring atoms are aligned with one another within a material, they may form a region of uniform magnetization known as a magnetic domain. The regions separating domains with different directions of magnetization are called domain walls, and the movement and blocking of these walls is fundamental to the magnetic properties of rocks. Grains containing just one magnetic domain throughout have strong and stable magnetic moments, whereas multi-domain grains have mobile domain walls with significantly lower and less stable magnetic properties. However, some large grains, pseudo-single-domains, do occur that take on some of the properties of single domains, complicating the simple view of the magnetic properties of materials based on small and large domains (DUNLOP, 1995).

Figure 10.1 illustrates the relationships between the induced (\mathbf{J}_{ind}) and remanent (\mathbf{J}_{rem}) magnetization components and an applied external magnetic field (\mathbf{B}_N) for a magnetized body. The induced component of magnetization does not exist in the absence of an external field because the magnetic moments of adjacent atoms due to orbital or spin motions of the electrons are randomly oriented by thermal motions (Figure 10.1(a)). However, in the presence of an external field such as the Earth's magnetic field, the magnetic moments are aligned with the external field resulting in a net magnetic moment or magnetization

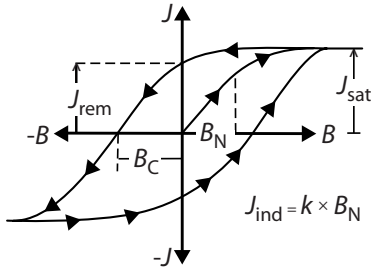

FIGURE 10.2 Hysteresis loop illustrating the non-linear relationships between the intensities of magnetization J of a magnetic body and the varying magnetic field B in which it is placed. J_{sat} and J_{rem} are the respective saturation and remanent magnetization intensities, B_C is the coercive force (field) intensity, and J_{ind} is the intensity of the induced magnetization which is the product of the normal magnetic field strength (B_N) and the magnetic susceptibility (k).

J_{ind} (Figure 10.1(b)). Any remanent component of the body’s magnetization is present, of course, in the absence of an external field (Figure 10.1(c)) and adds vectorially to the induced component to produce the total magnetization J_{tot} of the body (Figure 10.1(d)).

Figure 10.2 generalizes the non-linear and hysteretic behavior of magnetization \mathbf{J} for a magnetic body placed in a varying applied magnetic field \mathbf{B} . Subjecting an unmagnetized sample to the inducing magnetic field with increasing intensity causes the sample’s magnetization to increase along the curve until its saturation magnetization J_{sat} is reached. Upon decreasing the applied magnetic field to zero, the sample’s magnetization does not fall to zero along the same curve but decreases to the remanent magnetization J_{rem} . Reversing the polarity of the inducing field and increasing its intensity until the remanence is zero gives the coercive force strength B_C of the sample’s magnetization. Further increase of the intensity of the reversed applied field results in the magnetization attaining its negative saturation point that is antipodal to the positive saturation point. Again reversing the applied field and decreasing its intensity to zero and then increasing its intensity causes the sample’s magnetization to follow the lower curve in Figure 10.2 to its positive saturation level again. Varying the inducing field in a smaller cycle describes a smaller hysteresis loop for the sample’s magnetization.

In the weak terrestrial magnetic field, the slope of the magnetization curve in Figure 10.2 defines the sample’s magnetic susceptibility, k , or the ease with which a substance is magnetized by the external field. Magnetic susceptibility is a dimensionless quantity given by

$$k = \frac{J_{ind}}{B} \tag{10.1}$$

TABLE 10.1 Types of magnetization, their sources, and magnetic susceptibility ranges in CGSu.

Susceptibility	Type	Source
$k < 0$	Diamagnetism	Repulsive force due to the Larmor precession of orbits of electrons about an applied magnetic field.
$k \equiv 0$	Vacuum	
$0 < k < 10^{-6}$	Paramagnetism	Attractive force due to alignment of electron spin moments.
$10^{-6} < k < 1$	Ferrimagnetism	Adjacent magnetic domains occur in opposition, but with unequal magnetic moments resulting in a net magnetic moment in one direction.
$1 < k < 10^6$	Ferromagnetism	Quantum-mechanical exchange forces among atoms causing adjacent magnetic moments to orient parallel to each other forming magnetic domains.

Thus, in the Earth’s weak magnetic field B_N , the intensity of induced magnetization is $J_{ind} = k \times B_N$, where k must be measured in a weak inducing field of the order of magnitude of the Earth’s field (i.e. 40 A/m, or 0.5 Oe, or 50,000 nT). Equation 10.1 is the same in CGSu or SIu, but the susceptibility in CGSu is 4π times the value in SIu.

The interaction of the ambient (applied) magnetic field with the atoms of Earth materials leads to several types of responses which are identified as types of magnetization (Table 10.1). An understanding of these types of magnetization is important to understanding how magnetic property variations in Earth materials produce magnetic anomalies.

10.3.1 Diamagnetism

Diamagnetism occurs where each filled shell of electrons orbiting the nucleus of an atom has an even number of

electrons with one half orbiting in one direction and the other half in the opposite direction. Similarly, the spin directions of electrons are equally divided in opposite directions. This internal symmetry results in a net zero magnetic moment, and thus no external field. However, if the atom is placed in a magnetic field, the electrons will be subjected to a force causing a precession of the orbits about the direction of the external field. The precession results in an additional angular momentum in the direction of the field and a magnetic moment opposite to the applied field. The net opposing field is termed diamagnetism. This magnetism, which is universal to all atoms because the orbits of all electrons experience the precessional effect, opposes the applied magnetic field, the Earth's field in the case of terrestrial applications. The magnitudes of these opposing fields are very small and limited to the case where the electron shells are all filled so that the net magnetic moment is zero in the absence of an ambient field.

Several significant minerals are diamagnetic, including quartz, feldspars, and halite (rock salt). Their susceptibilities are of the order of 10^{-5} SIu. These minerals will produce a field that counteracts the Earth's field, but the magnitude of the field is negligible in comparison to the fields derived from other rock magnetization components, and thus the diamagnetic effect is observed only in special geologic conditions, such as in the presence of massive salt deposits that contrast with the positive magnetic susceptibility of the adjacent sedimentary rocks containing detrital magnetic grains.

10.3.2 Paramagnetism

Paramagnetism is caused by electron spins in atoms that are not offset or compensated by opposing spins of electrons within a shell of orbiting electrons. The uncompensated spins produce a magnetic field external to the atom. Such is the case for transitional elements like iron, titanium, chromium, and nickel. The spinning electrons produce a magnetic dipole. In the absence of an external field the net magnetic moment of these unpaired electrons in atoms is zero because of the disorganizing effect of thermal motions. Thus, the magnitude of paramagnetism is inversely proportional to temperature, a relationship referred to as Curie's law. However, in the presence of a magnetic field, the magnetic moments will favor a parallel alignment to the direction of the field. This results in a weak magnetization called paramagnetism which has a positive magnetic susceptibility, generally in the range of 10^{-3} to 10^{-5} SIu, and is inversely dependent on the temperature. Strong carriers of paramagnetism like the ions Fe^{2+} , Fe^{3+} , and Mn^{2+} cause many common rock-forming

minerals such as biotite, pyroxene, amphibole, olivine, and garnet to be paramagnetic.

10.3.3 Ferromagnetism

Ferromagnetism and its various subclasses, which are caused by interactions among neighboring atoms, results from groups of atoms, referred to as domains, aligning their magnetic moments parallel to each other. These magnetic domains, which have dimensions of the order of 10^{-6} m, expand in size under the influence of an external field by alignment of magnetic moments of neighboring domains in the direction of the field or, less commonly, by rotation of the domains into the direction of the external field. The latter situation may result because defects in the atomic arrangement impede growth, or can arise where the grain size is so small that growth potential is limited. The alignment of the domains in ferromagnetic materials leads to a magnetism that far exceeds that of para- or diamagnetism. This is the magnetism of ferrous metals like iron. A prominent characteristic of these materials is that they retain a magnetic moment in the direction of the inducing field after the field is removed. This hysteresis results from the blockage of the domains in their current alignment, effectively retaining a memory of the past field. Above a mineral-specific temperature these ferromagnetic properties are lost. At this temperature, the Curie temperature, ferromagnetic materials take on the properties of a paramagnetic material without the intense magnetism and the magnetic field memory (Figure 10.3).

The exchange forces between atoms in ferromagnetic materials cause adjacent atomic magnetic moments to be oriented in parallel, but other Earth materials exist in subclasses of ferromagnetism in which the adjacent atomic magnets are in opposition. These so-called antiferromagnetic materials behave much like paramagnetic materials, but they exhibit hysteresis, and their magnetic susceptibility increases with temperature up to a mineral-specific value at which the exchange forces disappear and the material behaves as a paramagnetic substance.

10.3.4 Ferrimagnetism

Ferrimagnetism is the most common form of magnetism causing magnetic anomalies. This is similar to antiferromagnetism in that the adjacent magnetic moments are in opposition, but the moments in the two allowable directions are unequal, resulting in a net magnetic moment parallel to the ambient magnetic field. Ferrimagnetic materials, possessing the properties of ferromagnetic substances, are the source of essentially all the magnetization in Earth materials. Magnetite (ferrite having the chemical

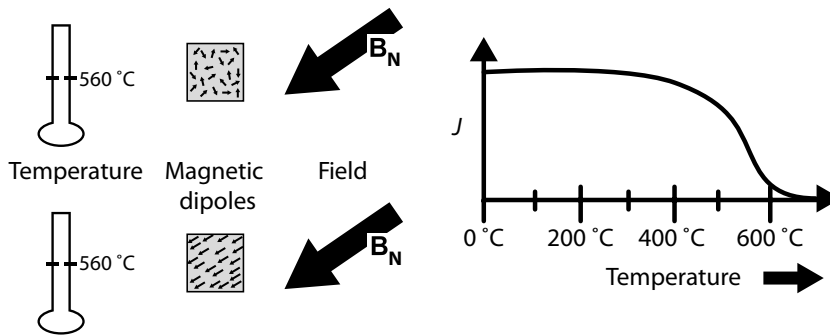

FIGURE 10.3 Ferromagnetic materials lose their magnetism above the Curie temperature because the thermal energy is sufficient to maintain a random alignment of the magnetic moments of the iron minerals. Materials acquire magnetism within roughly a few tens of °C of the Curie point as they cool through the Curie temperature to lower temperatures.

composition $\text{FeO-Fe}_2\text{O}_3$) is the principal naturally occurring ferrimagnetic component in the Earth. It has a much greater magnetic susceptibility than paramagnetic substances because of the interactions among adjacent atoms and the net magnetic moment in the direction of the external applied magnetic field.

10.3.5 Remanent or permanent magnetism

Remanent magnetization or magnetic remanence refers to the magnetization of ferrimagnetic materials that is taken on and retained from a prior magnetic environment. Unlike induced magnetization, remanent magnetization does not immediately disappear on termination of the ambient magnetic field. It is this form of magnetization that is the basis of paleomagnetic studies and an important source of magnetic anomalies. The relative importance of induced and remanent magnetization in Earth materials is presented in the form of the ratio of remanent to induced magnetization, known as the Koenigsberger ratio or Q . This ratio is highly variable among rock types: it can be 10 or higher in fine-grained rocks, such as basalt, which acquire an intense, stable remanent magnetization, whereas it seldom reaches values of 1 in coarse-grained plutonic rocks.

A wide variety of remanent magnetizations can be acquired by Earth materials during their formation and subsequent geological history. The summation of these magnetizations, both primary and secondary, is natural remanent magnetization (NRM). Primary magnetizations are acquired at the time of the formation of rocks and sediments. The most intense and stable is thermal remanent magnetization or thermoremanent magnetization (TRM) which is imposed upon a rock as it cools through the Curie temperature of the contained ferrimagnetic minerals (Figure 10.3). Most of the magnetization is obtained within a few tens of degrees of the Curie temperature, which is of

the order of 560°C for magnetite. Partial thermoremanent magnetization (PTRM) is the magnetization acquired over a specified interval of cooling temperature. TRM is the summation of a complete spectrum of individual PTRMs. Under rare conditions, which involve the crystallization of a particular mineral, ilmenohematite, the magnetization acquired is reversed to the ambient field and is called reversed thermoremanent magnetization (RTRM).

Detrital or depositional remanent magnetization (DRM) occurs in sedimentary rocks and sediments as a result of the rotation of interstitial grains into the preferred orientation of the ambient field during deposition. Its intensity is generally much less than that of TRM, and thus is not normally important in magnetic mapping.

Chemical remanent magnetization (CRM) is acquired during growth of magnetic minerals in an analogous manner to TRM, but magnetization occurs as the grain size increases while the temperature remains constant. The relationship between grain size and magnetization is complex, but for most minerals the remanent properties are “frozen in” at sizes well below 1 μm and remain constant or decrease with increasing size. An example of CRM is the formation of magnetite grains during serpentinization of ultramafic rocks (e.g. SAAD, 1969a,b).

Magnetizations are also imposed upon Earth materials subsequent to their formation. Anhyseretic remanent magnetization (ARM) is an intense form of magnetization which occurs over small surface areas that have been subjected to alternating fields associated with lightning strikes superimposed upon the steady main magnetic field. A prominent secondary magnetization that is found to a greater or lesser degree in all Earth materials is viscous remanent magnetization (VRM). Acquired over extended periods of time, VRM parallels the ambient field and can reach magnitudes approaching the magnetization induced by the terrestrial field. The time for domains to overcome

internal energy barriers, which inhibit the rotation of the magnetic moments into the ambient field, is called the relaxation time; it is directly proportional to the volume of the grains and inversely proportional to the ambient temperature. It increases with the base-10 logarithm (i.e. the log) of the period of time that the material is subjected to the field; that is, the change from time t to $10t$ is the same as the change from $10t$ to $100t$, etc. Thus, over extended periods of time, VRM may become a significant component of the NRM. In a similar manner the magnetization acquired in previous field directions is lost as a function of the log of time. Relaxation times of rocks have a range of values, but the time for the acquisition or decay of VRM may be very long, particularly in fine-grained rocks. This permits VRM, once acquired, to exist for geologic periods measured in millions of years.

10.4 Mineral magnetism

The vast majority of the minerals making up rocks, sediments, and other Earth materials are either diamagnetic or paramagnetic, so they have little impact on the magnetic character of these materials and their role in magnetic mapping is restricted to special situations. However, there are several accessory minerals in rocks that are ferrimagnetic, making them important in geological mapping with the magnetic method. They occur in the titanomagnetite, titanohematite, and iron sulfide series of solid solutions.

10.4.1 Titanomagnetite series

The magnetization of Earth materials is primarily due to magnetic minerals of the ternary system $\text{FeO}-\text{Fe}_2\text{O}_3-\text{TiO}_2$, with minor additional minerals of the $\text{Fe}-\text{Ni}-\text{S}$ system, and ferrous metal alloys. The latter include native metals, especially iron, which occurs rarely in nature, and anthropogenic ferrous metals. The ternary system, shown in Figure 10.4, includes three solid-solution series involving most of the minerals that control magnetism within the Earth, although not all components of the series contribute to the magnetic properties. The most magnetically significant components occur in the titanomagnetite series which joins ulvöspinel (Fe_2TiO_4) and magnetite ($\text{FeO}-\text{Fe}_2\text{O}_3$). As indicated in the diagram, the series generally is not complete because, under most geological conditions, cooling of the series from high temperature causes exsolution to the end components, essentially pure magnetite and either ilmenite (FeTiO_3) or ulvöspinel at room temperatures. Under oxidizing conditions, a common state in nature, ulvöspinel will be converted to an intergrowth of ilmenite and magnetite.

The magnetic properties of titanomagnetites vary as the ratio of ulvöspinel to magnetite changes. The Curie temperature and saturation magnetization increases with decreasing titanium content in a complicated manner depending on the arrangement of the metal ions in the lattice structure. The saturation magnetization is the maximum value of magnetization that can be obtained by the mineral, although the terrestrial field is not strong enough to cause saturation. Magnetic susceptibility and the intensity of TRM are not strongly dependent on composition, because of the overriding effect of grain size (CLARK and EMERSON, 1991). Fine-grained titanomagnetites of the order of $1\ \mu\text{m}$ in size are lower in magnetic susceptibility and higher in specific intensity of the TRM than are larger-grained components. However, the susceptibility is effectively zero for ulvöspinel contents greater than about 70%. Ulvöspinel is paramagnetic at normal temperatures.

Magnetite, the most important and most common magnetic mineral, is ferrimagnetic and has a Curie temperature of about 560°C , a temperature not exceeded in crust with normal geothermal gradients. The presence of increasing titanium in the solid solution series decreases the Curie temperature. As a result, a Curie temperature of 500° to 550°C is more realistic for much of the magnetite in the crust because of its titanium content. Magnetite has a strong saturation magnetization and an intense volume magnetic susceptibility. DUNLOP and ÖZDEMİR (2007) give the volume magnetic susceptibility of multidomain magnetite as 3 SIu, whereas CLARK and EMERSON (1991) give volume susceptibilities of single-domain grains of dispersed magnetite from approximately 1 to 6 SIu with susceptibilities of massive, coarse-grained magnetite ranging upward from these single-grain values to 1 or more SIu. These values will be decreased by internal demagnetization as a result of grain-shape anisotropy. The magnetic susceptibility decreases as the Curie temperature is approached, becoming paramagnetic at that temperature.

10.4.2 Titanohematite series

The solid solution between ilmenite (FeTiO_3) and hematite (Fe_2O_3), referred to as the titanohematite or ilmenohe-matite series (Figure 10.4), is second in importance to the titanomagnetite series in Earth materials. The magnetic characteristics of the series are complex and strongly dependent on composition. Upon slow cooling from a high temperature, the components of this series exsolve into the end members, hematite, which is antiferromagnetic but carries a weak magnetism due to a parasitic ferromagnetism in the basal plane of the crystal structure, and

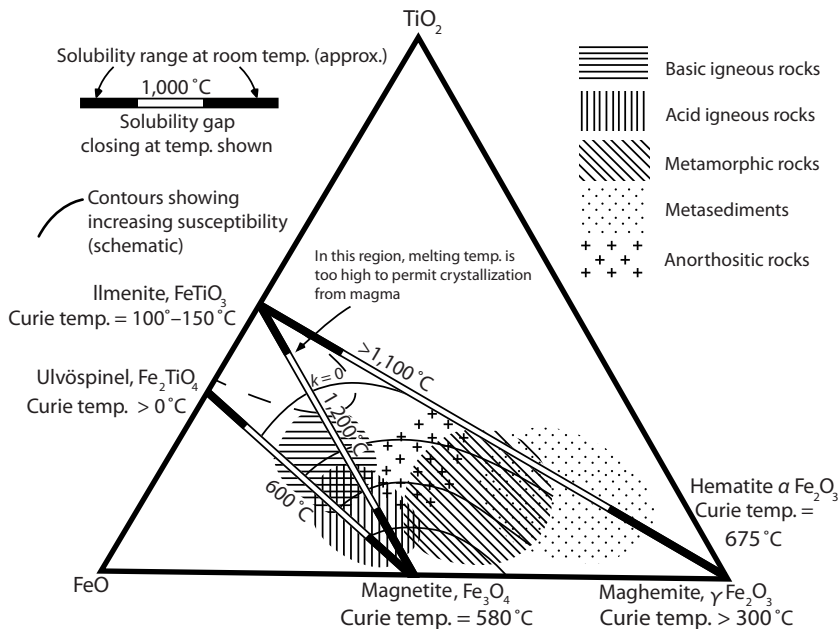

FIGURE 10.4 Review of mineralogical and magnetic data pertaining to the $\text{FeO-TiO}_2\text{-Fe}_2\text{O}_3$ system. After GRANT (1984a,b).

ilmenite, which is paramagnetic at normal temperatures. In the range of this series where ilmenite makes up between 45 and 90% of the total composition, the product is ferrimagnetic and, under special conditions of rapid cooling and specific grain sizes, the products undergo spontaneous self-reversal from the ambient magnetic field. However, in the normal situation involving slow cooling of the rock, the series exsolves to its end members, ilmenite and hematite.

A ferrimagnetic form of Fe_2O_3 , maghemite or gamma-hematite ($\gamma\text{Fe}_2\text{O}_3$), forms under low temperature ($< 200^\circ\text{C}$) oxidation. Maghemite forms a solid solution series with magnetite that has overall properties similar to magnetite. The other components of the $\text{FeO-TiO}_2\text{-Fe}_2\text{O}_3$ ternary system are paramagnetic, and thus are not an important part of the magnetism of terrestrial materials for exploration purposes.

10.4.3 Iron sulfides

Iron sulfides (FeS_{1+x}) with a range of compositions and magnetic properties occur in a variety of Earth materials. The common form, pyrite (FeS), is paramagnetic, and thus is not an important magnetic constituent. However, monoclinic pyrrhotite (Fe_7S_8) and greigite (Fe_3S_4) are ferrimagnetic. The Curie temperature of pyrrhotite is roughly 320°C , and the magnetic susceptibility is an order of magnitude less than magnetite, but it is a function of grain

size with higher susceptibilities associated with coarser-grained pyrrhotite. As a result, pyrrhotite can be an important component of the magnetic character of certain Earth materials such as deep-seated igneous rocks and amphibolites.

For example, pyrrhotite is the dominant carrier of magnetization at depths greater than about 300 m in the 9 km deep drill hole in Bohemia (BOSUM *et al.*, 1997; BERCKHEMER *et al.*, 1997). The pyrrhotite has a Koenigsberger ratio generally greater than 1, owing to a soft chemical remanent magnetization. Pyrrhotite also occurs as a secondary mineral in strongly reducing environments in recent sulfide-rich sediments and sedimentary rocks which interact with hydrocarbon seepage.

Greigite, which is the sulfide analog of magnetite, has a similar high magnetic susceptibility. Apparently, it is chemically unstable in most sedimentary environments where it is likely to form. Like pyrrhotite, it can be produced by sulfate-reducing bacteria. Native iron, which is strongly ferromagnetic, also can contribute to the magnetization of rocks, but it occurs only rarely in nature because of the ease with which it is oxidized.

10.4.4 Fluids and gases

Fluids and gases within the Earth have very minor influence on the magnetic properties of rocks and are diamagnetic. The susceptibilities of both water and oil are of the

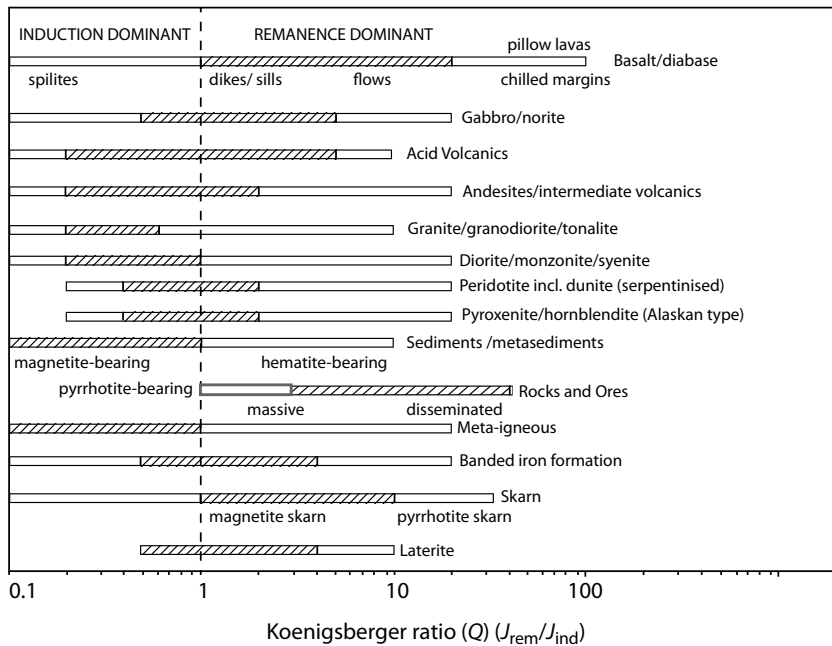

FIGURE 10.5 Summary of the range of the Koenigsberger ratio ($Q = J_{rem}/J_{ind}$) for a variety of rock types. Induced magnetization is dominant below $Q = 1.0$. Diagonally ruled segments denote the typical ranges observed in nature. After CLARK and EMERSON (1991).

order of 10^{-5} SIu, and air and hydrocarbon gases have a susceptibility roughly two orders of magnitude smaller.

10.5 Magnetic susceptibility

Several magnetic properties are reported to a greater or lesser extent for rocks, minerals, and other terrestrial materials in physical property compilations. The most common of these and the one that has the most general significance to geophysical exploration is magnetic susceptibility, the ease with which a substance is magnetized. This property controls the induced magnetization in rocks and other materials. It is the principal property of diamagnetic and paramagnetic materials as well as a critical parameter of ferrimagnetic materials. Induced magnetization (J_{ind}) is generally considered to dominate remanent magnetization (J_{rem}) in rocks, particularly plutonic and sedimentary rocks. This is illustrated in Figure 10.5 which shows the range of the Koenigsberger ratio ($Q = J_{rem}/J_{ind}$) of a variety of types of rocks. Diagonally ruled segments denote the most common values observed in nature. Volcanic rocks and mafic plutonic rocks (e.g. gabbro, norite) generally have remanent values exceeding their induced magnetization. Intense and stable remanence predominates in rocks that contain fine-grained magnetite (generally less than $20 \mu\text{m}$). Induced magnetization dominates in granitic and metamorphic rocks containing predominately coarse-

grained magnetite that make up the vast majority of the upper basement rocks of the continents.

Table 10.2 lists several types of magnetic susceptibilities that in practice are used in explaining the relatively simple property that relates induced magnetization of a substance to the ambient magnetic field (e.g. HANNA, 1977). Magnetic susceptibility varies with the intensity of the ambient field, so measurements of this property are made at weak fields of the order of the terrestrial field. Accordingly, magnetic susceptibilities reported in geophysics are all weak-field susceptibilities. Susceptibilities can be given in terms of their mass or volume. In classical physics, susceptibility is generally given in terms of mass or the equivalent specific susceptibility. However, in geophysics, susceptibilities generally are given in terms of their volume, because calculations of magnetic fields of bodies are based on considerations of their volume rather than their mass. Accordingly, susceptibilities presented in the geophysical literature should be assumed to be weak-field volume magnetic susceptibilities unless noted otherwise. The mass susceptibilities are converted to volume susceptibility by multiplying by density.

The susceptibility reported in most geophysical literature is the weak field, true or intrinsic, magnetic susceptibility, k . This is sometimes referred to as the bulk magnetic susceptibility, as it is the sum of the susceptibilities of the constituent materials. In most terrestrial materials this

TABLE 10.2 Types of magnetic susceptibilities used in magnetic methods.

Type	Symbol	Definition
Weak-field susceptibility		Magnetic susceptibility in a field roughly equivalent to the terrestrial field (≈ 40 A/m)
Mass susceptibility	k_m	Magnetic susceptibility per unit mass
Volume susceptibility	k	Magnetic susceptibility per unit volume
True susceptibility	k	Magnetic susceptibility of the sum of the susceptibilities of the constituent materials
Intrinsic susceptibility	k	Equivalent to true susceptibility
Apparent susceptibility	k_a	Magnetic susceptibility of a body considering its internal demagnetization
Effective susceptibility	k_e	Magnetic susceptibility which produces magnetization equivalent to the scalar sum of induced and remanent magnetizations [$= k(1 + Q)$ where $Q = J_{rem}/J_{ind}$]
Crystalline susceptibility		Magnetic susceptibility of a specific crystallographic direction in a substance

is dominated by ferrimagnetic components, but it can be influenced by the contributions of paramagnetic materials (CLARK and EMERSON, 1991) especially in crystalline mafic rocks.

The true susceptibility normally reported in the geophysical literature disregards internal demagnetization effects. Demagnetization arises from an internal field due to the presence of magnetic poles on the surface of a magnetic body. This occurs wherever the lines of the magnetic field cross a magnetic boundary. The internal field decreases the ambient field within the magnetic body, effectively decreasing the magnetization, and thus the magnetic susceptibility. The susceptibility of a body considering its internal demagnetization is the effective magnetic susceptibility, $k_e = k/(1 + Nk)$, where N is the demagnetization factor. The demagnetization factor is a function of the shape of the magnetic volume and direction of the ambient magnetizing field, varying from 0 for magnetization along the long axis of a needle-shaped body to 4π for magnetization across a flat surface, in CGSu. The demagnetization factor in SIu is denoted by $D = N/4\pi$. In practice, demagnetization is negligible where true susceptibility values are less than about $1,250 \times 10^{-4}$ SIu or $10,000 \times 10^{-6}$ CGSu.

Another useful form of magnetic susceptibility is apparent magnetic susceptibility, k_a , which considers the magnetization induced by the ambient field, as well as the remanent magnetization assuming it parallels the ambient magnetic field. This latter assumption is approximated where the remanent magnetization is primarily VRM. Effective magnetic susceptibility can be calculated from $k_e = k(1 + Q)$. This apparent susceptibility should not be confused with “apparent magnetic susceptibility (permeability)” that is used to describe the susceptibility com-

puted from the in-phase electromagnetic response of the Earth in the absence of electrical conduction currents (e.g. HUANG and FRASER, 2000; WON and HUANG, 2004).

A complication to magnetic susceptibility which is a potential source of dispersion in the tabulation of measurements of a specific rock type is magnetic susceptibility anisotropy. This anisotropy originates from demagnetization effects related to the shape of the grains and to magnetocrystalline anisotropy. The latter is the result of magnetic domains in crystalline materials being more easily magnetized along some crystallographic directions than others. For example, magnetite which has a cubic crystalline structure is more easily magnetized along one of its diagonals. The effect in magnetite is negligible at terrestrial field intensities. This is not the case for the components of the titanohematite and pyrrhotite series which have a minimum susceptibility normal to their basal plane. Magnetic susceptibility is a second-ranked tensor, and thus consists of nine components which can be reduced to six by invoking the law of conservation of energy.

Shape anisotropy can have a marked effect on the susceptibility of rocks which have a strong orientation of the long axes of the ferrimagnetic minerals, a common occurrence in some sedimentary and metamorphic rocks. For example, the long dimensions of ferrimagnetic minerals tend to lie in the bedding planes of detrital sediments and in the foliation planes of metamorphic rocks. These minerals are magnetized more easily in the long directions because of the minimal effect of internal demagnetization. As a result, the maximum magnetic susceptibility is parallel to the planar structures and the direction of lineation. This leads to the use of anisotropic magnetic susceptibilities in petrofabric studies of flow fabrics in volcanic rocks, paleocurrent investigations in sediments and sedimentary

rocks, and foliation of igneous and metamorphic rocks. However, the interpretation of magnetic anomalies from highly laminar formations also needs to consider magnetic susceptibility anisotropy (e.g. BATH, 1962).

The degree of magnetic susceptibility anisotropy is given simply as the ratio of the maximum to the minimum susceptibility. Although in most geophysical applications we assume this value is 1 (i.e. the susceptibility is isotropic), measurements of this property of sedimentary, volcanic, and metamorphic rocks vary from 1.0 to 1.2 or more with increasing parallelism of the ferrimagnetic minerals. Strongly foliated metamorphic rocks may reach ratios of 2.0, and banded iron formations may have anisotropies of 4 or more (JAHREN, 1963). In contrast, plutonic rocks seldom have measurable anisotropies.

Magnetic susceptibility is a dimensionless quantity. Traditionally, however, in CGSu, volume magnetic susceptibility has been incorrectly expressed as EMu/cm³, rather than in the correct form which is simply CGSu. In SIu, each CGSu of susceptibility is equivalent to 4 π (e.g. PAYNE, 1981; SHIVE, 1986).

The volume percentage of magnetite in a rock can be useful for estimating its magnetic susceptibility because magnetite is the principal source of magnetic susceptibility in Earth materials. Numerous studies have been made of this relationship with somewhat different results. The magnetite content of rocks is either estimated by magnetic separation of the magnetite or calculated from chemical analyses of the Fe₂O₃ and FeO content of the material. The differences in the results of these studies reflect variations in magnetic susceptibility of magnetite largely due to the presence of TiO₂ within the magnetite crystalline structure, to grain size and shape, and to the interaction of the magnetic field of the magnetite grains. These factors are a function of rock type and geologic history of the material. Therefore, observed variations in the results of empirical studies of the relationship between magnetite content and magnetic susceptibility are to be expected.

The volume magnetic susceptibility of magnetite as indicated in Figure 10.6 varies from a value in SIu of near unity to 10 or more depending upon the grain size and the chemical composition. Higher values are associated with pure magnetite and coarser grains. However, the apparent magnetic susceptibility of magnetite as measured on specimens or *in situ* is considerably less than indicated in Figure 10.6. SLICHTER (1929) found that the apparent susceptibility k_a of magnetite can be represented in the form

$$k_a = \frac{k_m V}{1 + k_m N(1 - V)}, \quad (10.2)$$

where k_m is the true magnetic susceptibility of magnetite, and V is the fraction volume of magnetite. For a rock

with 1% magnetite by volume where the demagnetization factor $N = 3$, which corresponds to grains of a prolate spheroidal shape, and $k_m = 1.0$, the apparent volume magnetic susceptibility k_a is 0.0314 SIu or 0.0025 in CGSu. STACEY (1963) suggested that typically magnetite grains are in the form of a prolate spheroid with a mean axes ratio of 1.5, which leads to a value of $N = 3.9$ where the grains are distributed randomly. Using Slichter's formula, the apparent susceptibility is 0.0264 SIu (= 0.0021 CGSu). In contrast, the slope between magnetic susceptibility and magnetite content of 0.0377 SIu (or 0.003 CGSu) has been widely used in dealing with Earth materials which have volumes of magnetite of up to several percent distributed throughout them as shown in Figure 10.7 (e.g. NETTLETON and ELKINS, 1944; DOBRIN and SAVIT, 1988). The relationship is roughly linear for up to only several volume percent, and becomes more complicated at larger concentrations, probably owing to the interactions among the magnetite grains.

Figure 10.6 presents a useful compilation of the magnetic susceptibilities of a variety of rock types and pertinent minerals. The susceptibility that is given is the true weak-field volume magnetic susceptibility, which is simply referred to as the magnetic susceptibility. This is the susceptibility used in the calculation of magnetic anomaly fields assuming that the remanent magnetization is negligible and the susceptibility value is weak ($<1,250 \times 10^{-4}$ SIu).

The previously described generalizations regarding magnetic susceptibilities and rock types are clearly evident in Figure 10.6. The shaded areas in the susceptibility ranges indicate typically occurring values. As CLARK and EMERSON (1991) point out, there are two shaded areas for numerous rock types, indicating a bimodal distribution of susceptibilities caused by the presence or the absence of ferrimagnetic minerals. These bimodal distributions complicate the identification of a specific susceptibility with a rock type. Further information is required on the geochemistry of the rock, reflecting its origin and subsequent geological and thermal history, to decide which grouping of susceptibility should be assigned to a specific rock unit.

10.6 Magnetization of rocks and soils

The preceding description testifies to the potential complexity of the magnetization of Earth materials. Magnetization is a function not only of the chemical composition and origin of the material, but of its geological and thermal history.

The primary rock-forming minerals are either diamagnetic or paramagnetic, and thus contribute in only minor

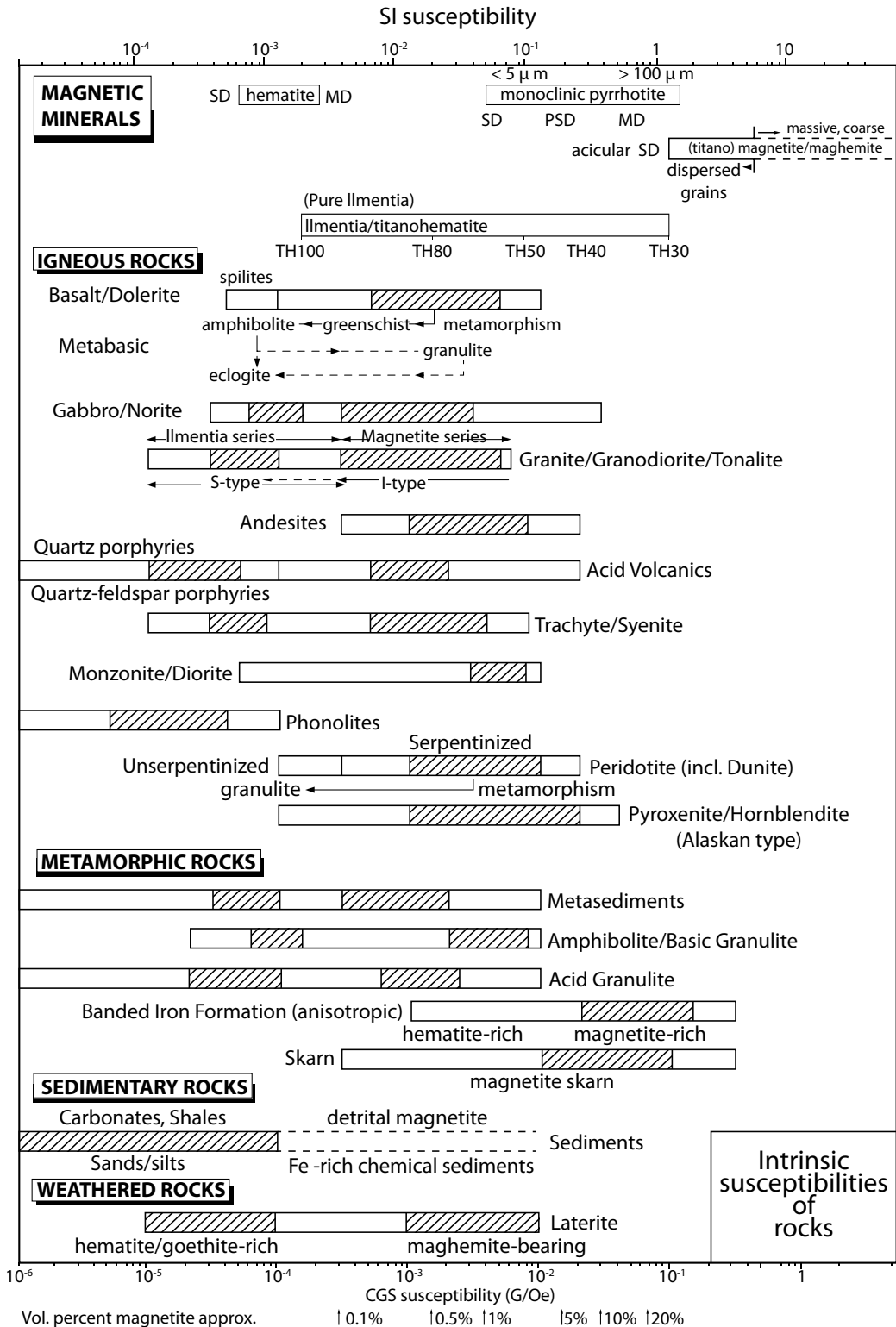

FIGURE 10.6 True or intrinsic volume magnetic susceptibility as measured in weak magnetic fields. After CLARK and EMERSON (1991).

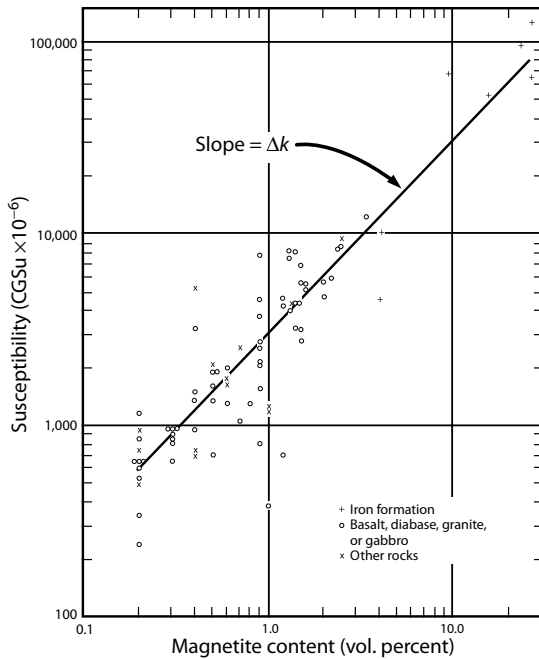

FIGURE 10.7 Data showing the linear relationship of magnetic susceptibility with up to several percent volume concentration of magnetite. The slope of the line indicates that the susceptibility, k , is approximately 0.003 CGSu (0.0377 SIu) units for each percent concentration of magnetite up to several percent in a rock. After MOONEY and BLEIFUSS (1953).

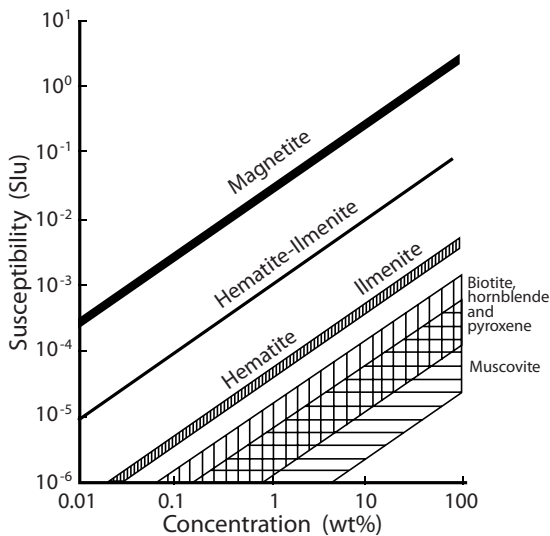

FIGURE 10.8 Mineral contributions to rock susceptibility as a function of their concentration by percent weight. From TARLING and HROUDA (1993), after SCHÖN (1996).

ways to the magnetism of the vast majority of rocks where minerals of the titanomagnetite or titanohematite series or magnetic pyrrhotites are present. This is well illustrated in Figure 10.8, which shows schematically the contribution of minerals to susceptibility of a rock as a function of their weight percent (wt%) concentration within the rock. In rocks with only very small quantities of ferromagnetic iron oxide or sulfide minerals, paramagnetism associated with minerals consisting of iron and magnesium such as biotite, hornblende, pyroxene, olivine, and garnet will significantly contribute to magnetic susceptibility. A number of studies have investigated the general magnetic character of rocks and the factors that cause variations in these properties (e.g. STACEY and BANERJEE, 1974; HAGGERTY, 1979; O'REILLY, 1984; GRANT, 1984a,b; WASILEWSKI, 1987; SHIVE *et al.*, 1988; REYNOLDS *et al.*, 1990; HENKEL, 1991; SCHÖN, 1996).

10.6.1 Igneous rocks

Igneous rocks, which originate from the solidification of magma, make up a prominent part of the continental crust and the vast majority of the oceanic crust as well as underlying mantle. Thus, they are a significant source of magnetization in the Earth where the temperature is below the Curie point of the constituent magnetic minerals – i.e. the temperature above which these minerals revert to a paramagnetic state. Igneous rocks may occur either as plutonic rock that has solidified within the Earth or as volcanic rock that originates in either subaerial or subaqueous conditions. The bulk composition of igneous rocks varies greatly depending on the source of the molten rock and the nature and degree of differentiation of the components during the intrusion, extrusion, and solidification of the magma.

The primary classification of igneous rocks is on the basis of their mineralogy reflecting their bulk chemical composition. Those that are rich in silica are referred to as felsic (or acidic) with granite and rhyolite (the volcanic equivalent of granite) being the primary types. These rocks occur primarily in the upper crust of the continents. At the other end of the composition spectrum are mafic (or basic) rocks rich in iron and magnesium that make up the great majority of the oceanic crust and the lower continental crust. Ultramafic rocks which are relatively higher in iron and magnesium and lower in silica make up the upper mantle and occur only rarely in the crust. The magnetic properties of igneous rocks depend on the bulk rock composition, but also their oxidation state, hydrothermal alteration, and metamorphism. As a result the magnetic properties are related in complex ways to the source of

the igneous rocks, geological setting, and history of subsequent geochemical processes (CLARK, 1999).

Mafic rocks contain greater amounts of iron and titanium oxides than felsic rocks (roughly 5% versus 1%), and thus commonly have greater magnetizations. However, this generality is subject to error from factors other than chemical composition. For example, titanomagnetite minerals occurring within mafic rocks tend to be higher in titanium, and thus have weaker magnetizations and lower Curie point temperatures. The rates of cooling and the availability of oxygen have a profound effect on the solubilities of the magnetic oxide solid solutions, and thus the resulting magnetic minerals, their grain size, and magnetization. Components of the Fe–Ti–O solid solution series undergo spontaneous separation (exsolution) as the rocks cool. This separation is important because it results in increasing magnetization, Curie temperatures, and magnetic susceptibilities. During the cooling process, rocks undergo alteration with the oxidation of ulvöspinel toward ilmenite and the formation of strongly magnetic magnetite. If high-temperature oxidation continues to an advanced stage within the solid solution series, as it can in subaerial mafic volcanic rocks, magnetization may be decreased by the formation of non-ferrimagnetic components. Additionally, subsequent low-temperature oxidation will convert magnetite to low-magnetization hematite.

The magnetic components of igneous rocks and their magnetic properties are also affected by the rate of cooling of the molten magma. In mafic volcanic rocks (e.g. basalt) the rate of cooling is high; volatiles, including oxygen, readily escape and the iron/titanium oxides tend to remain in solid solution, resulting in lower magnetic susceptibilities. However, the small grain sizes of the iron/titanium magnetic oxides are magnetically stable, and thus have high coercivities and remanent magnetization stabilities. This situation is evident in the integrated magnetization of the roughly 6 km of mafic rocks of the oceanic crust (HARRISON, 1987) which has an estimated induced component ranging from 0.15 to 0.34 A/m and a remanence of 0.90 to 3.71 A/m. Typically the Koenigsberger ratio of volcanic rocks is greater than those of more coarse-grained slower-cooled plutonic rocks (Figure 10.5) owing to their smaller grain size resulting from higher cooling rates. However, viscous remanent magnetization may be an important part of the magnetization of coarse-grained plutonic rocks.

In addition to the effect of grain size on magnetization, the shape of magnetic mineral grains in all types of rocks affects the overall magnetization because of the anisotropic nature of ferromagnetic minerals. Anisotropy arises from intrinsic variation in the ease of magnetization with crys-

tallographic directions and from shape demagnetization. This is not a factor in most plutonic rocks, but can have an effect in volcanic rocks which have flow structures.

A common generality of rock magnetism is that felsic rocks, i.e. granitic rocks, are less magnetic than more mafic rocks. However, observations show that the magnetic susceptibility of felsic rocks is bimodal (Figure 10.6). The more magnetic mode is identified with the magnetite series of granites that are of the I-type mode which have a dominantly igneous or meta-igneous source, while the lower-magnetization granites, the S-type, are believed to originate in sedimentary rocks with a strong interaction with crustal materials (CHAPPEL and WHITE, 1974; CLARK, 1999). However, it is problematic to relate the magnetization of the granite to its origin, depth of source, or tectonic regime in any global sense although this may be possible in a restricted regime based on localized investigations. The distinction between magnetite-bearing (magnetite series) and magnetite-barren (ilmenite series) granites is in the higher oxidation state of the former. The origin of this higher oxidation state may be primary or secondary processes, or the source material which in turn may reflect differing tectonic regimes. The magnetization of rhyolitic rocks, the volcanic equivalent of granitic rocks, also may be either high or low. In this case the high magnetization is associated with selective intense thermal remanent magnetization.

10.6.2 Metamorphic rocks

Metamorphic rocks – those whose mineralogy, texture, and structure have been modified in the solid state by temperature and pressure – have variable magnetic properties and occupy large volumes of the continental crust. The changes caused by metamorphism may be local as around a specific igneous pluton, or involve a region where broad, low-gradient temperature and pressure have altered the original rocks. The former may cause intense magnetic effects over a few tens of kilometers or less. In contrast, regional metamorphic effects may cover extensive regions measured in hundreds of kilometers. Regional metamorphism commonly is associated with dynamic processes of plate margins. The effects of metamorphism may be profound on the magnetic characteristics of the rocks depending on the source rock (especially its iron content), the temperature regime, the chemical effects brought about by the temperature/pressure conditions, and especially the oxidation state. The latter controls the amount and type of iron oxides that form and the partitioning of the iron between oxides and silicates. Rocks of similar bulk chemistry may have quite different magnetizations

as a result of metamorphic processes. PULLAIAH *et al.* (1975) show how magnetization of the magnetic minerals in rocks is gradually lost during heating accompanying burial and metamorphism; the reverse occurs during uplift and cooling with the acquisition of viscous remanent magnetization.

HAGGERTY (1979) notes that metamorphism usually decreases the magnetization of igneous rocks. For example, little remanence survives greenschist facies metamorphism. However, there are notable exceptions to this generality. For example, GRANT (1984a,b) describes the production of magnetite by the breakdown of hydrous iron/magnesium-bearing silicates with increasing temperature. While under intense metamorphism which produces granulite-grade rocks, iron/titanium oxides recombine to form magnetite-ilmenite solid solutions, causing a decrease in overall magnetization. There is a tendency for an increase in magnetic susceptibility and viscous remanent magnetization with increasing metamorphic grade as a result of increasing grain size which permits easier domain-wall movement. Viscous remanent magnetization may increase with temperature up to the vicinity of the Curie temperature, with Koenigsberger values of the order of one and direction similar to the ambient terrestrial magnetic field.

Hydrothermal alteration of ultramafic rocks such as peridotite and dunite leads to serpentinization and is normally accompanied by a marked change in magnetization (SAAD, 1969a,b). The remanent magnetization developed as a result is mainly chemical remanent magnetization (CRM). During serpentinization at low temperatures ($\sim 300\text{--}400^\circ\text{C}$) the iron atoms released from the silicate structure of paramagnetic olivine and pyroxene, are oxidized to form ferrimagnetic magnetite. The intensity of both remanent and induced magnetization increases exponentially with serpentinization. At the early stages of serpentinization, the magnetite grains produced are fine-grained and in most cases single domain, producing a very stable CRM. As the degree of serpentinization increases, the magnetic minerals grow from single to multi-domain size. The growth in grain size is accomplished by coagulation of the earlier fine grains rather than by a nucleation process. The remanent magnetization becomes highly unstable as the rock becomes intensely serpentinized due to the growth of magnetite grains to multidomain size and their oxidation, in some cases, to maghemite. The intensity of magnetization depends on mode of occurrence and state of oxidation of the magnetite, as well as on original rock composition. Serpentinized dunite was found by SAAD (1969a) to be less magnetic than equally serpentinized peridotite because the olivine in the dunite has a lower iron content

than the olivine and pyroxene in the peridotite. Therefore, it is expected that serpentinized ultramafic bodies will have highly variable associated magnetic anomalies with those of dunitic composition having lower magnetic anomalies. The effect of serpentinization of ultramafic rocks on magnetic susceptibility (k), remanent magnetization (J_{rem}), and Koenigsberger ratio (Q) is illustrated in Figure 10.9.

With increasing prograde metamorphism of serpentinized ultramafics, Mg and Al may be substituted into the magnetite causing a decrease or destruction of magnetization (CLARK and EMERSON, 1991). Metamorphism progressively can demagnetize serpentinites changing them to paramagnetic at granulite grade. Subsequent retrograde serpentinization, however, may cause the rock to become magnetic again. SHIVE *et al.* (1988) found that susceptibilities generally decrease with increasing metamorphic grade. They explained that to be due to the production of increasing amounts of chrome-rich spinel which dilutes the magnetite component.

The effect of metamorphism upon sedimentary rocks generally is minimal except where iron-rich minerals are present in the source rocks. For example, in ferric oxide-bearing iron formations, metamorphism may cause reduction of the oxides to magnetite. The result is a metamorphosed iron formation with both intense magnetic susceptibility and remanent magnetization. However, under continuing intense metamorphism, the iron oxides may be further modified to silicates that have minimal magnetic properties. In a similar manner, rocks containing pyrite may be converted to magnetite as a result of high-temperature processes.

10.6.3 Lithospheric rocks

Long-wavelength magnetic anomalies observed in satellite magnetic measurements and low-pass filtering of regional and continental-scale magnetic data sets have focused attention on magnetic sources within the lower crust and in the lithosphere in general (e.g. FROST and SHIVE, 1986; SHIVE *et al.*, 1992). Analysis of these anomalies, considering the best estimates of the thickness of the magnetic lithosphere, indicates overall magnetizations of the magnetic lithosphere ranging from 2 to 10 A/m, with 4 A/m a typical value. These magnetizations are of the order of 10–100 times the average value of upper crustal rocks as well as uplifted lower crustal rocks. Accordingly, additional sources of magnetization are required in the deep magnetic lithosphere.

Studies of deep rock fragments (xenoliths) and uplifted lower crustal rocks as well as thermodynamic considerations have led most investigators to the conclusion that

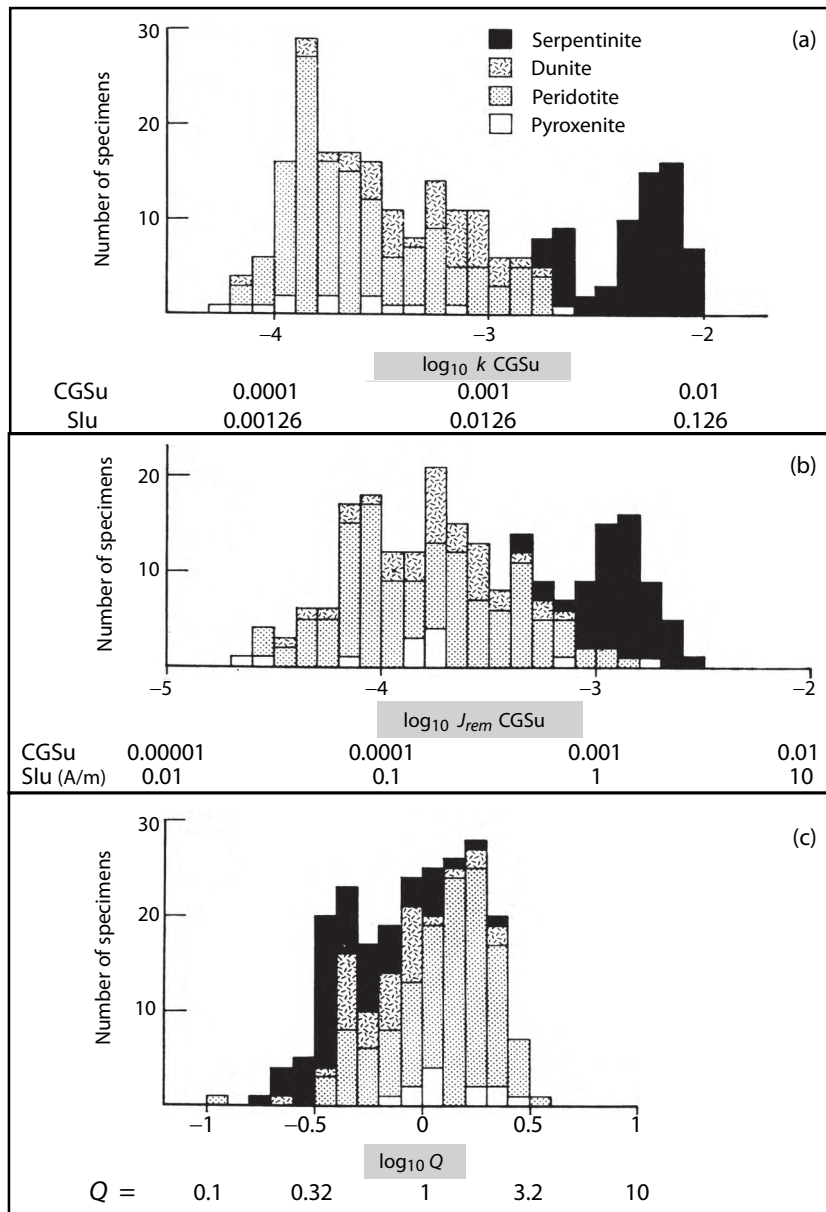

FIGURE 10.9 Histograms of (a) magnetic susceptibility (CGSu), (b) intensity of natural remanent magnetization (CGSu), and (c) Koenigsberger ratio of ultramafic rocks and their metamorphic product, serpentinite (SAAD, 1969a).

magnetite is probably the major source of magnetism in the lower crust (e.g. WASILEWSKI and MAYHEW, 1982; KELSO *et al.*, 1993). The depth extent of this magnetism is controlled by the Curie temperature of magnetite, which is about 600 °C in the deep crust owing to pressure effects. This temperature generally is reached near the base of the crust at the Mohorovičić discontinuity (or Moho) in the continents and slightly below the Moho in the oceans. KELSO *et al.* (1993) have measured the mag-

netic properties of granulitic rocks originally located in the deep crust and now cropping out in the Proterozoic Arunta Block of central Australia and found a median natural remanent magnetization of 4.1 A/m and a Q of 7.2. Laboratory investigations indicate that nearly 50% of the remanence persists after 400 °C demagnetization, suggesting that thermo-viscous remanent magnetization along the ambient magnetic field may dominate the magnetization in lower crustal rocks. The magnetic susceptibilities of these

rocks are only capable of producing magnetizations of less than 1 A/m and the susceptibility of the primary magnetic mineral, magnetite, is constant to within 30 °C of the Curie temperature where it decreases rapidly. WASILEWSKI *et al.* (1979) present evidence that the Moho is a magnetic boundary, because iron is dominant in highly magnetic oxide phases within the crust and in non-magnetic spinels below the crust. HAGGERTY (1978) alternatively has suggested that metallic iron and iron alloys produced during serpentinization of the upper mantle are a source of magnetism within the upper mantle. However, FROST and SHIVE (1986) have argued against this as a major source of magnetism on geologic, petrologic, and thermodynamic grounds.

A number of other sources of deep magnetization have been considered as the source of long-wavelength magnetic anomalies. The evidence that monoclinic, ferromagnetic pyrrhotite is the major carrier of magnetism in the deep (9 km) drill hole in Bohemia offers a possible source of deep magnetization. Further, studies by KLETETSCHKA *et al.* (2000a,c) of the intensity of thermal remanent magnetism in multidomain-sized grains of titanohematite suggest that titanohematite could be an important source of remanent magnetization in lower crustal rocks, in contrast to the general assumption of prevailing induced magnetization of these rocks. This is supported by the work of MCENROE and BROWN (2000) showing that metamorphic titanohematite carrying intense remanent magnetization is commonly present in granulites formed in lower crustal metamorphism. KLETETSCHKA *et al.* (2000b) have also suggested that the thermal remanent magnetization of multidomain hematite and titanohematite may be a significant source of crustal magnetic anomalies on Mars. Regardless of the origin of lithospheric magnetization, a major source of magnetization is present in the lower crust, and the continental crust is more magnetic on average than the thinner oceanic crust as a result of its greater thickness.

Over the past few decades studies of the Moon and Mars have shown that these planetary bodies have local magnetic fields due to crustal magnetization, despite the lack of a global magnetic field which causes induced magnetization. On the Moon, about 4.2 billion years ago, the loss of heat caused the liquid core to disappear and along with it the core dynamo action which had produced an early, generally axially oriented global magnetic field. However, rocks formed prior to the termination of the field acquired a weak normal remanent magnetization which is still preserved in local regions of the Moon, particularly on its far side. This magnetization likely decreased with time and may have been altered by shock magnetization

associated with impacts and perhaps other local processes. This conclusion is based on analysis of the measured magnetic field of the Moon, which reaches intensities of only a few hundred nanoteslas, and measurements of lunar rocks (MACKE *et al.*, 2010).

Similarly, Mars, which lost its global magnetic field on cooling more than 4 billion years ago, has local magnetic fields, particularly in the southern highlands. However, in contrast to the Moon, the magnetization of Martian, crustal rocks is intense, as determined from inversion of magnetic anomalies and measurements of meteorites originating on Mars. This magnetization is roughly 10 times that of the Earth. Although several processes have been suggested for the magnetization of the Martian crust, it is likely that the source is remanent magnetization acquired during the span of time when Mars had a global magnetic field. A candidate for this intense remanence is lamellar magnetization (MCENROE *et al.*, 2007) associated with micrometer to nanometer intergrowths of ilmenite and hematite, leading to intense remanent magnetizations with high coercivity. This would explain the strong normal remanent magnetization which remains after more than 4 billion years. Similar magnetizations are observed on Earth in anorthositic ilmenite deposits which can carry strong remanent magnetizations that originated in Precambrian time (ROBINSON *et al.*, 2004), and in hematite ore bodies in which very small amounts of magnetite and maghemite intergrowths within the hematite lead to normal remanent magnetization of strong coercivity (SCHMIDT *et al.*, 2007). In the latter case the intergrowths are not exsolution lamellae, but were formed when the rocks were exposed to a high-temperature period. These studies of extraterrestrial bodies are providing new information that is potentially helpful in understanding terrestrial magnetic properties and processes.

10.6.4 Sedimentary rocks

Characteristically sedimentary rocks, both chemical and detrital, are significantly less magnetic than crystalline rocks, owing to the lack of ferrimagnetic minerals. These minerals may be absent as a result of non-deposition or because of post-depositional geochemical alteration which transforms them into non-magnetic minerals. The type and amount of ferrimagnetic minerals deposited in sediments is a function of the type of source rocks. Typically they are more abundant where the source is crystalline rocks, but the ferrimagnetic minerals commonly are oxidized to non-magnetic forms during the weathering and erosion of these rocks and deposition of the detrital particles into sediments. Nonetheless, there are numerous examples of

clastic sedimentary rocks that contain measurable amounts of ferrimagnetics giving rise to small, low-amplitude magnetic anomalies (e.g. MUSHAYANDEBVU and DAVIES, 2006; HUDSON *et al.*, 2008; GRAUCH and HUDSON, 2011). These anomalies are difficult to map, except where they are steeply folded or faulted, without high-resolution and -sensitivity magnetic surveying because thin, shallow-dipping magnetic sedimentary units produce only minor short-wavelength anomalies at their edges (e.g. GRAUCH and HUDSON, 2007). GRAUCH and HUDSON (2011) have compiled the volume magnetic susceptibility of sedimentary rocks from numerous regions over North America. They find that, despite a wide variation in susceptibility within rock types, the values are generally less than 2×10^{-3} SIu (160×10^{-6} CGSu) with the higher values for sandstones and shales primarily from detrital magnetic minerals, and lower values for chemically precipitated rocks such as carbonates and salts.

In contrast to the minor quantity of detrital ferrimagnetic minerals in most sedimentary rocks, significant quantities of magnetite (commonly >10% by weight) occur in Archean and Early Proterozoic iron formations in which ferrous iron has precipitated from sea water before the advent of an oxidizing atmosphere and oceans. These chemical sediments are among the most magnetic rocks (e.g. BATH, 1962; JAHREN, 1963). Another specialized sedimentary rock in terms of potential magnetic properties is coal. Coal, which consists primarily of preserved organic material, also contains minor quantities of pyrite (FeS_2) because of the localized reducing environment and activity of sulfate-reducing bacteria. Although pyrite is paramagnetic, and thus only a minor magnetic mineral, it is transformed into significant magnetic minerals, such as magnetite, maghemite, and hematite, as well as perhaps pure metallic iron (DE BOER *et al.*, 2001), when subject to thermal oxidation during fires and subsequent cooling below the Curie point of the magnetic minerals. The transformed mineral phases depend on a variety of conditions including the bulk composition of the original sedimentary rock and the environment during the thermal oxidation. DE BOER *et al.* (2001) find enhanced magnetic properties of thermally altered coals from northwest China that range from 0.1 to 10 A/m for the TRM and susceptibilities of 10^{-2} to 10^{-1} SIu. Adjacent sedimentary rocks, too, may suffer oxidation of indigenous pyrite due to the high temperatures (800–1000 °C) reached by the nearby burning coal. Additionally, SCHUECK (1990) indicates that pyrite in coal is chemically oxidized into magnetic minerals, and thus magnetic mapping may be used to isolate sources of acid mine drainage within coal mines and dumps.

Highly magnetic minerals also may occur in minor amounts in sediments as a result of post-depositional processes which lead to localized magnetic oxides and sulfides, and preservation of detrital ferrimagnetic particles. The localized regions may be associated with geochemical or biological activity promulgated by mineral and hydrocarbon deposits. The possible generation of magnetic ferrous iron oxides and sulfides in sedimentary rocks overlying hydrocarbon deposits (e.g. DONOVAN *et al.*, 1979, 1984, 1986; HENDERSON *et al.*, 1984; MACHEL, 1996), and thus the direct detection of buried hydrocarbons, has led to sporadic studies of the source of this possible relationship (REYNOLDS *et al.*, 1990; PHILLIPS *et al.*, 1998).

Magnetite is the most common ferrimagnetic mineral present in sedimentary rocks, but titanohematite may be the dominant magnetic oxide in some rocks (REYNOLDS, 1977). Magnetite is deposited in sediments along with other high-density minerals where moving water can no longer sustain the transport of these heavy minerals owing to a decrease in the velocity of the water. This leads to concentrations of magnetite associated with, for example, shoreline depositional features and changes in stream or river character. Ferrimagnetic sulfides may originate in sedimentary rocks as a result of microbial activity. They are uncommon, but may occur as monoclinic pyrrhotite or cubic greigite in either oxidizing or reducing environments. The resulting mineralization may be sufficient to produce minor magnetic anomalies.

10.6.5 Soils

Soils form a special component of the investigation of the magnetic properties of Earth materials because of the unique nature of soil processes and the human impact upon them. Their magnetic properties are important to the use of the magnetic method in archaeological, environmental, and other near-surface studies.

Generally, the magnetic properties of soils bear little relation to their parent rocks (COOK and CARTS, 1962) because during the chemical breakdown of the rocks the iron-rich minerals are converted to non-magnetic phases. However, under certain conditions they will reflect those of the rock types at the source or their provenance. Such is the case where the soils contain numerous lithic fragments and minerals whose magnetic properties have not been altered, owing to insufficient time or prevailing environmental conditions.

In the north-central USA, for example, soils have developed on glacial debris and sediments transported by Pleistocene continental glaciers from the Precambrian Shield of Canada into the United States (GAY, 2004). These soils

contain numerous crystalline (igneous and metamorphic) rock materials which maintain their magnetic character. The distribution of these magnetic components varies with the rock types of their provenance, the distance from the source, and the effects of local glacial-related processes. The former two effects alter the magnetic properties on a regional scale depending on the source area of the glacial lobe which deposited the material and the distance from the source, whereas the glacial processes are effective locally within the glacial deposits of any particular lobe (HINZE, 1963; GRAVENOR and STUPAVSKY, 1974). An example of the latter is the concentration of magnetic materials within deposits (eskers) associated with streams flowing on or within glaciers during melt periods (ONESTI and HINZE, 1970). The irregular distribution of the magnetic components within glacial materials and glacially derived sediments results in randomizing of any remanent magnetization and highly variable magnetic susceptibilities.

An example of magnetic properties derived indirectly from the parent rock is the strong magnetization observed in lateritic soils formed in tropical climates on mafic rocks (e.g. RESENDE *et al.*, 1986). The magnetic phase of these soils is titanomaghemite, which presumably is derived from primary titanomagnetite originating in the underlying bedrock.

Topsoils generally exhibit substantially higher magnetizations than the underlying subsoils (LE BORGNE, 1955, 1960). Magnetic susceptibility is enhanced in the uppermost layers, including the surficial A-horizon and well into the B-horizon, decreasing gradually an order or two of magnitude over roughly the first meter. This enhancement has been ascribed to the conversion of iron oxides from the weakly ferrimagnetic hematite to the strongly ferrimagnetic magnetite and maghemite by soil combustion from surface fires and fermentation from seasonal surface reduction and oxidation processes. Additional, more limited, contributions may come from magnetite created by microbial activity, either internally in magnetotactic microorganisms, which are bacteria that align with the ambient magnetic field, or externally in iron-reducing bacteria (BAZYLINSKI and MOSKOWITZ, 1997), and from atmospheric deposition of anthropogenic particulate pollution (MAHER, 1986).

Looking at this in more detail, enhancement of topsoil magnetization is principally associated with successive periods of reduction and oxidation in soils. In this process the non-ferrimagnetic oxides naturally occurring in soils, such as hematite, are reduced to magnetite or a phase close in composition to magnetite and subsequently may be oxidized to maghemite which has approximately twice the magnetic susceptibility of the original iron oxides

(AITKEN, 1972). This process can be initiated by the reduction associated with natural or human-induced burning of organic material in soils that is followed by the reoxidation of magnetite as air enters the soil pore spaces after the fire. A secondary origin of this process which is much more widespread, but produces lower magnetization enhancement, is the fermentation process (MULLINS, 1977) which consists of relatively rapid alternating oxidation and reduction periods associated with wetting and drying climatic cycles.

Soil fermentation involves reducing hematite to magnetite at ordinary temperatures by decay of organic matter during wet, oxygen-starved or anaerobic periods. Alternating anaerobic and dry, oxygen-rich or aerobic conditions must be fairly rapid because a prolonged period of high humidity can cause the removal of oxygen molecules by the soil microbes, thereby allowing the water-soluble iron to leach out where sufficient soil drainage occurs. The characteristics and consequences of the fermentation mechanism are not well known because attempts to produce magnetic enhancements by accelerated fermentation in the laboratory have been relatively unsuccessful (LE BORGNE, 1960; SCOLLAR *et al.*, 1990). However, the fill from archaeological pits usually is more magnetic than the surrounding topsoil, which suggests that fermentation enhancements may be significant on archaeological timescales (AITKEN, 1972).

Repeated burning of the topsoil by natural and domestic fires is probably the primary way that the hematite–magnetite–maghemite conversion is achieved. Burning organic material produces both a strong reducing environment of carbon monoxide and a temperature increase to accelerate the reduction process. Reoxidation to maghemite occurs during subsequent cooling when air again reaches the soil. In general, a fire magnetically enhances the soil to a depth of only a few centimeters because of the low thermal conductivity of soils. Subsequent worm and other animal burrowing action, cultural activities, and soil sedimentation processes disperse the more magnetized soil layer underlying the fire to greater depths.

The magnetic susceptibility enhancement from soil combustion can be studied in the laboratory by oven-heating the soil to temperatures typical of archaeological fires (e.g. 350–650 °C) in a reducing environment of nitrogen and then cooling it in the oxygenated environment of air (TITE and MULLINS, 1971). These studies show a marked linear enhancement of specific magnetic susceptibility with increasing concentrations of iron up to several weight percent. Typical behavior is illustrated in Figure 10.10 where the specific (mass) susceptibilities

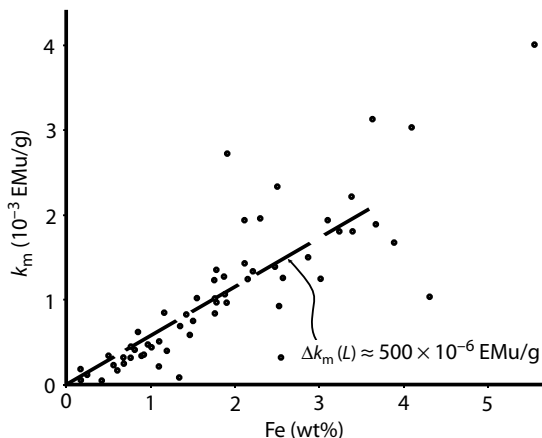

FIGURE 10.10 Typical relationship between specific (mass) magnetic susceptibility (k_m) and the weight percent (wt%) of iron (Fe) in soils oven-heated in a reducing (nitrogen) environment and then cooled in an oxidizing (air) environment to simulate the effects of archaeological fires. The slope $\Delta k_m(L)$ of this relationship for the first several weight percent is also indicated. After GRAHAM (1976).

(k_m) of laboratory heated soils were found to follow a slope of about $\Delta k_m(L) = 0.005 \text{ EMu/g}$ over the first several weight-percent. Beyond several weight percent, the relationship is no longer linear, possibly owing to complex magnetic interactions of the iron oxide grains. Thus, the susceptibility enhancement from soil combustion is relatively predictable because most soils have iron oxide weight concentrations of several percent or less (e.g. TITE and MULLINS, 1971; TITE, 1972; AITKEN, 1972; MULLINS, 1974; ROTH *et al.*, 1974; GRAHAM, 1976; LATZ *et al.*, 1981; SCOLLAR *et al.*, 1990).

For non-agricultural soils with organic concentrations less than 2%, significant magnetic enhancement during combustion also results from increasing the organic content (e.g. MULLINS, 1974; GRAHAM, 1976). Susceptibility increases strongly as the organic matter content in the soil increases up to about 2% where the reduction effect is apparently maximum and the fired soil shows no further susceptibility enhancement with greater organic content. Human activities increase the soil's organic content, which in a low-organic soil containing iron oxides can significantly enhance the magnetism of fired soil and the role of the magnetic method for mapping these activities.

Magnetic susceptibility enhancement of topsoils at archaeological sites, however, is due primarily to the amount of soil fired, which is proportional to the number of fires that the site has experienced. Thus, the soils most conducive to magnetic exploration are organic-rich with significant concentrations of iron oxides and an extensive history of occupation. Glacial soils of the US midconti-

nent, for example, commonly exhibit high (>2 wt%) iron oxide concentrations (e.g. ROTH *et al.*, 1974; LATZ *et al.*, 1981), and thus tend to be relatively well suited to magnetic exploration for fired soil artifacts.

The amount of iron oxides actually converted to the more magnetic phases in soils can be estimated from the conversion factor $CF = [k_m(F)/k_m(L)]$, where $k_m(F)$ is the susceptibility measured from field samples of the soil, and $k_m(L)$ is the laboratory-measured maximum susceptibility of the soil when presumably the iron oxides have all been converted by oven-baking the soil in the reducing-then-oxidizing environment (TITE and MULLINS, 1971). In English soils, for example, the CF for iron oxides from archaeological soil features was found to vary from 10% to 35% with an average of $\langle CF \rangle \approx 11\%$, whereas for soils at non-archaeological sites, the CFs ranged typically around 2–3% (e.g. TITE, 1972; MULLINS, 1974). Thus, an empirical CGSu estimate of the magnetic volume susceptibility for UK soils at archaeological sites may be obtained from

$$k \approx \Delta k_m(L) \times \langle CF \rangle \times \text{wt\%} \times \sigma$$

$$= 5.5 \times \text{wt\%} \times 10^4 \quad (10.3)$$

for the soil density σ in g/cm^3 . However, in practice the strong viscous magnetic remanence of soils may amplify this susceptibility by 2–4 times.

The enhancement of soil magnetization from iron oxide conversions can grow significantly with time owing to magnetic viscosity that produces typically strong viscous remanent magnetizations (VRM) in soil. As the result of magnetic viscosity, the magnetization, J_t , at any given time, t , relative to its magnetization, J_{t_0} , at an earlier time, t_0 , is

$$J_t = J_{t_0} \left[1 + (V_c) \log \left(\frac{t}{t_0} \right) \right], \quad (10.4)$$

where the proportionality constant V_c is the viscosity constant, which can be measured from a sample of the soil (SCOLLAR *et al.*, 1990). Typical values for V_c range between 3–6% so that the increase in the magnetization of a soil feature over typical archaeological timescales can be considerable. For example, a 5% value for V_c results in a 45% net increase in magnetization between $t_0 = 100$ s and $t = 3,000$ yr. Thus, the magnetization enhancement from the conversion of iron oxides in topsoils may well more than double when magnetic viscosity is taken into account. SCOLLAR *et al.* (1990) provide additional details on the magnetic properties of soils at archaeological sites and their measurements.

Soils overlying sanitary landfills also have higher magnetic susceptibilities. ELLWOOD and BURKART (1996)

ascribed this to the growth of magnetite-producing bacteria prompted by reducing conditions from methane gas rising from decaying organic matter and the periodic infiltration of surface precipitation. Under these conditions iron is transported deeper in the soil where it is reprecipitated and oxidized into the magnetic phase, maghemite, during dry summers in much the same manner as occurs in normal soils. In a similar manner, plumes of rising methane above hydrocarbon deposits produce conditions favorable for the occurrence of magnetic ferrous iron oxides and sulfides, both monoclinic pyrrhotite and greigite (e.g. REYNOLDS *et al.*, 1990; MACHEL, 1996).

In summary, the volume magnetic susceptibility of the uppermost soils can vary widely (e.g. BUTLER, 2003), generally over the range of 0.001–0.01 SIu with most values occurring within the range of 0.002–0.006 SIu. Archaeological disturbances of organic, iron-oxide rich soils can significantly enhance topsoil magnetizations, because of weakly magnetic hematite being reduced to strongly magnetic magnetite which oxidizes to strongly magnetic maghemite. The NRM of magnetic soils is likely to be appreciable because magnetite occurs in ultra-fine grains susceptible to VRM and the effects of heating due to surface fires. The Koenigsberger ratio can be 2 or more in surface soils.

10.6.6 Fired clay

Like soils, fired clay may be significant and useful in archaeological engineering, and other near-surface investigations. Fired clay objects like pottery, tiles, bricks, kilns, hearths, and fire pits are subjected to temperatures that often exceed the Curie point of their constituent iron minerals (e.g. 680 °C for hematite). As a result, these materials acquire a TRM that is stable and intense and directed in the ambient magnetic field. Where temperatures do not reach the Curie points, PTRM will be acquired. These magnetizations often are studied to date the firing of the clay as well as for other archaeological purposes. The magnetizations range from roughly 0.3 A/m for red oxidized clays to 300 A/m for gray reduced or gleyed clays (AITKEN, 1972; SCOLLAR *et al.*, 1990). Fired clay objects in general tend to be characterized by relatively strong magnetizations and magnetic anomalies with intensities second only to those of iron objects.

10.6.7 Iron objects

Iron objects from metallic iron and alloys of Fe–Ni–Co are the most magnetic materials that are likely to be encountered in the near-subsurface. Metallic iron is rare in nature,

and thus iron objects are related to human activities where their occurrence in the subsurface may be either deliberate or inadvertent. Their magnetic properties are highly variable depending on their chemical constituents and thermal, mechanical, and chemical history. The volume magnetic susceptibility of iron objects is commonly reported between 10 and 125 SIu, while the magnetic moment per unit of weight, which is useful to consider in many applications, is given by BREINER (1973) as 10^5 to 10^6 CGSu (EMu) per 1,000 kilograms or 10^8 to 10^9 A×m² in SIu. RAVAT (1996) found that the effective apparent magnetic susceptibility of unruled steel drums is of the order of 100 SIu and that the Koenigsberger ratio generally is less than 0.5. In contrast, BREINER (1973) and others report ratios of 10 to 100 for iron and steel objects. These high values show that strong remanent magnetizations are possible, depending on the mechanical history of the object and its exposure to direct current electrical fields. RAVAT (1996) found inconsistent, but only minor modifications of the magnetic properties of steel drums exposed to rusting over a several-year span of time, indicating complex magnetic changes at least in the early stages of natural weathering.

10.6.8 Summary

The above generalizations illustrate that great care must be taken in specifying the magnetic properties of classes of rocks, soils, and anthropogenic features. Magnetic properties commonly depend on factors involving the geological, geochemical, and thermal history of the materials which may not be readily apparent without detailed study of the composition, texture, and magnetic properties of magnetic as well as the non-magnetic minerals, and the structural and stratigraphic relationships between rock units.

A useful summary of the crustal distribution of the aeromagnetically important minerals is shown in Figure 10.11. Magnetite, the most important magnetic mineral, is produced and destroyed under a complex array of environments and conditions that lead to strong magnetic susceptibility and may cause low remanent magnetization, or weak susceptibility and high remanent magnetization. Furthermore, generalizations are difficult because some rocks contain strongly magnetic minerals other than magnetite. The result is that prediction of magnetic properties on the basis of Earth material type can only be made in broad terms.

Intense magnetic properties are associated with certain soils, fired iron-rich clays, and iron objects. As a result localized magnetic anomalies commonly are related to anthropogenic sources which make them useful to

MAGNETIC MINERAL	CRUSTAL SETTING AND ROCKTYPE					
	OCEANIC CRUST	CONTINENTAL CRUST				
		MIDDLE AND LOWER CRUST	UPPER CRUST AND SURFACE			
	IGNEOUS AND METAMORPHIC ROCKS			SEDIMENTARY ROCKS		
				Hydrothermal alteration/ Thermal alteration/ mineralization		Diagenetic/ Epigenetic
Fe (-Ti) OXIDES						
Magnetite	●	●	●	■	●	●
Titanomagnetite	●	●	●	●	●	●
Titanomagnemite	■					■
Titanohematite			●	●	●	●
METALLIC Fe	?	?				
Fe-Ni-Co-Cu alloys	?	?				
Fe SULFIDES						
Pyrrhotite				■		■
Fe ₇ S ₈						
Greigite						■
Fe ₃ S ₄						

EXPLANATION
 ● Primary ■ Secondary ●/ Depleted ? Diagenetic

FIGURE 10.11 Aeromagnetically important minerals of the crust in terms of their distribution and origin. The minerals are divided into primary (dot) and secondary (square) origins. Primary minerals are (1) crystallized in magma, (2) deuteric alteration products in igneous rocks or metamorphic products in metamorphic rocks, or (3) detrital minerals in sedimentary rocks (including chemically precipitated magnetite, such as that deposited in banded iron formations). The dot-with-slash symbol denotes settings or conditions where minerals may be depleted. Diagenetic magnetite is denoted by a bold question mark. Secondary minerals include those formed by replacement of earlier magnetic precursors (e.g. titanomagnemite from titanomagnetite in oceanic crust) and those formed by nucleation or from a non-magnetic precursor. The size of the symbols crudely indicates their relative abundance within a single column and cannot be meaningfully compared between columns. After REYNOLDS *et al.* (1990).

archaeological investigations and other studies where the surface has been disturbed, and in some cases where foreign materials have been placed in the near-subsurface.

Much of the information on near-surface magnetic properties is disseminated in the literature on studies by soil scientists, archaeogeophysicists, and environmental geomagnetists, and thus is not readily available in a form that is immediately useful to geophysical site characterization. Environmental magnetism, the application of rock and mineral magnetic studies to the environmental impacts of the transport, deposition, and alteration of magnetic materials, is being used for a wide range of environmental problems including the effects of global change, climatic change, and human impact on the environment (e.g. VEROSUB and ROBERTS, 1995). These studies are an increasing source of near-surface magnetic properties.

10.7 Magnetic property measurements

As in the case of density, the magnetic properties of subsurface materials used in planning and interpretation of surveys are commonly based on values extracted from published compilations of magnetic property measurements.

However, the wide range of measured magnetic properties for any Earth material type means this can lead to less than satisfactory results. The use of data tabulations often is a necessity because of the lack of samples for measurements or of appropriate instrumentation, but wherever possible direct measurement of samples is the desirable course of action. Care must be taken to insure that the samples are representative and that the number of measurements is adequate to test the variability of the property within any one subsurface unit. Guidelines provided in Section 4.6.1 on density measurements for the selection and number of samples are useful for magnetic property measurements as well.

Two magnetic properties characteristically are of interest for magnetic exploration purposes: magnetic susceptibility and the remanent magnetization, both its intensity and its direction. As explained previously, the former controls induced magnetization and the latter is the magnetization that is present in a zero external field. The two combine to make up the total magnetization that is the source of magnetic anomalies.

Magnetic susceptibility has been measured over the years by numerous techniques, including magnetic

balances and inductance bridges. Alternatively, measurements can be simply made by determining the effect that a rock sample has on the position of a magnetic needle. A similar method is to measure the effect of rotating a specimen near a resonance magnetometer. JAHREN and BATH (1967) and BREINER (1973) describe such a method that provides a rough measure of both induced and remanent magnetization components. The procedure involves rotating a roughly equidimensional rock sample at a specified distance from a total intensity magnetometer in either the Gauss A (i.e. parallel to ambient magnetic field direction) or Gauss B (i.e. perpendicular to the field direction) position while observing how the magnetic field changes from the ambient field without the sample present. The magnetic moment of the sample in the induced case is equal to the product of the magnetic susceptibility, the ambient magnetic field, and the volume of the sample, all in common units. The field for measuring the remanent component is equal to one-half the difference between the maximum and minimum measurements of the magnetometer observed while rotating the sample. For measuring the induced component (magnetic susceptibility), the field is the difference between the ambient field measurement and the average of the observed maximum and minimum observed fields.

More commonly and more accurately, measurements are made on the basis of the effect of a magnetic rock sample on an inductance bridge. The rock sample is placed within a winding of one leg of the bridge, or close to it near proximity, and the imbalance of the bridge caused by the sample is determined and related to the magnetic susceptibility through calibration using materials or fluids of known magnetic susceptibility. The magnetic field to which the specimen is exposed is of the same order of the magnetic field at the surface of the Earth, 30,000–60,000 nT. The frequency of alternating fields used in these balances is kept low (<5 kHz) to avoid conductive responses from the high electrically conductive magnetic minerals. The measurements are affected not only by the susceptibility, but also by the viscous magnetization retained by the sample in the short duration of the alternating field reversal. In some instruments, the viscous magnetization of very fine-grained magnetic minerals is identified by determining the susceptibility at two frequencies a decade apart (CLARK and EMERSON, 1991). A lower susceptibility is measured at the higher frequency if viscous magnetization affects the results.

Inductance bridges are available that measure the susceptibility of a set volume of material in the shape of a cylindrical sample obtained from drill core, or granular samples placed in a cylindrical specimen holder for mea-

surement. In the latter case, the porosity of the sample must be determined to adjust the measurement to the actual volume of the sample. For measurements of susceptibilities on individual samples or outcrops of either consolidated rocks or unconsolidated sediments and soils, susceptibility bridges are modified to include the Earth material within the effective region of the field of the coil. The size of the coil controls the depth range which is tested by the bridge. Typically these depths are less than several centimeters (LECOANET and SEGURA, 1999); nonetheless, *in situ* bridges provide rapid, effective measurements which do not require the collection of samples. Particularly useful are portable hand-held, induction bridge magnetic susceptibility meters that store numerous measurements for later downloading into a computer for analysis.

Other variations on these bridges enable remote measurements to be made by probes inserted into soils and downhole logging devices. For example, DANIELS and KEYS (1990) describe a downhole logging sensor with a sensitivity of 10^{-6} SIu, which consists of a solenoid wound on a high permeability core connected to an inductance bridge. The magnetic susceptibility of the volume of rock surrounding the sensor is determined from the amplitude of the quadrature (out of phase) component of the bridge output signal. For specialized purposes, it may be useful to measure the directional properties of magnetic susceptibility, the magnetic anisotropy (e.g. HANNA, 1977; BORRADAILE and HENRY, 1997).

The remanent magnetic properties of Earth materials are also determined by a number of methods. All require carefully selected samples that are oriented prior to their extraction from the Earth. As mentioned above, remanent magnetization can be determined by measuring the effect of rotation of an appropriately oriented nearby sample on the observations of a magnetic sensor (e.g. BREINER, 1973; RAVAT, 1996). However, most remanent magnetizations of significance to geophysical exploration are measured by the spinner magnetometer, or rock generator. This magnetometer spins an equidimensional, oriented sample next to a pickup coil or magnetic sensor. The amplitude and phase of the recorded signal are used to determine the intensity and direction of the remanent component orthogonal to the spin axis. By spinning the specimen around various axes and measuring the resultant sinusoidal output, the total remanent component and its direction relative to the sample, and thus to the Earth, are determined.

10.8 Magnetic property tabulations

Geophysical texts generally provide brief tabulations of the range of magnetic susceptibilities of common rock

types. In addition, several comprehensive compilations of magnetic properties, primarily magnetic susceptibilities, have been published (e.g. SLICHTER, 1942; LINDSLEY *et al.*, 1966; PARASNIS, 1971; DORTMAN, 1976; HENKEL, 1976; STRANGWAY, 1981; CARMICHAEL, 1982; CLARK, 1983; CLARK and EMERSON, 1991; HUNT *et al.*, 1995; SCHÖN, 1996; DUNLOP and ÖZDEMİR, 2007; CHANDLER and LIVELY, 2011; GRAUCH and HUDSON, 2011). Detailed measurements of rocks from specific regions or of particular rock types also are presented in numerous journal publications (e.g. WERNER, 1945; MOONEY and BLEIFUSS, 1953; BATH, 1962; JAHREN, 1963; LIDIÁK, 1974; ISHIHARA, 1979; KRUTIKHOVSKAYA *et al.*, 1982; CRISS and CHAMPION, 1984; LAPOINTE *et al.*, 1984; HAHN and BOSUM, 1986).

As we said, using tabulations of magnetic properties requires care because the results are often presented in the form of histograms showing the frequency of occurrence of values within a specified range. The range of values is given in some reports in a linear manner, while others are shown on a logarithmic scale. The latter are common because of the broad range of magnetic properties which often cover several orders of magnitude (LARSSON, 1977). Normal distributions of values will be skewed when presented on a log scale. This distortion can be misleading if the significance of the logarithmic scale is not fully appreciated.

Typical examples of log-normal frequency plots are shown in Figure 10.12 for 4,621 measurements of magnetic susceptibility of drill cuttings of all rock types, gneisses, and metabasites (metamorphosed mafic rocks) from a 9,100 m deep drill hole in Bohemia (KTB-HB). Figure 10.12(a) shows the two maxima of the histogram for all rock types due to the two main lithologies in the (b) and (c) panels. RAUEN *et al.* (2000) ascribe the tail of the histograms toward increased susceptibilities to larger contents of ferromagnetic phases such as pyrrhotite. They find that the increased values of the metabasites over the gneisses are due to the greater abundance of strongly paramagnetic minerals such as hornblende in the metabasites. Although monoclinic ferrimagnetic pyrrhotite is the primary strongly magnetic mineral in the rocks over most of 9,100 m depth of the hole, the magnetite-rich zones are responsible for the higher susceptibility values.

Generalized tabulations of magnetic properties, although informative in a general way, are less useful than tables of rock densities and often of limited assistance in evaluating the magnetic character of rocks in a specific area. Magnetic properties are characteristically heterogeneous within a rock type at all scales, measured from sub-centimeter to kilometer distances. This is true because

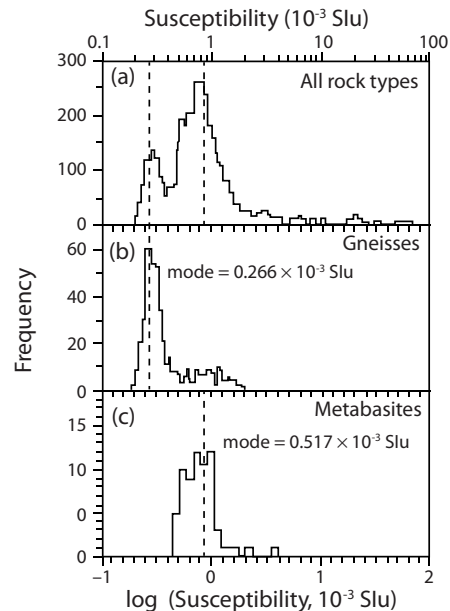

FIGURE 10.12 Log-normal frequency plots of magnetic susceptibility measurements from drill cuttings from the main deep drill hole in Bohemia (KTB-HB). (a) All rock types (4621 measurements); (b) gneisses (503 measurements); (c) metabasites (67 measurements). The modes of the gneisses and metabasites histograms are marked and specified. After RAUEN *et al.* (2000).

of the irregular distribution of ferrimagnetic minerals and the inconsistent distribution of the effects of secondary processes. This heterogeneity, referred to by NETTLETON (1976) as the Principle of Infinite Detail, generally increases with increasing magnetization of the rock, and the variations are greater between rock types from different geological provinces than for a rock type within a specific province because of variable geologic and thermal histories of provinces.

The distribution of magnetic properties within a range for a specific rock type may not be characteristic of the rocks in a specific region, owing to localized effects that produce or destroy ferrimagnetic components. As a result, tabulations that provide only a range can lead to inappropriate conclusions if the simple mean of a range is used in analyses. Clearly, tabulations that provide results from the study area are most desirable; where these are not available, the user of general tabulations needs to be concerned with the statistical attributes of the tables.

10.9 Key concepts

- Magnetization, or in actuality the magnetization contrast, the controlling physical property of the magnetic method, is the vectorial resultant of the induced and

remanent magnetizations. Induced magnetization is a function of the magnitude and direction of the ambient magnetic field and of the magnetic susceptibility of the material, the ease with which the material is magnetized. Remanent magnetization is a permanent magnetization that reflects the history and origin of the material.

- The magnitude of remanent magnetization is generally much less than induced magnetization, but the exceptions are numerous and noteworthy, and the direction of the remanent magnetization is commonly not in the orientation of the ambient field. As a result, it is difficult to estimate magnetization except in very general terms that are subject to numerous exceptions. The resulting uncertainty is amplified by the fact that magnetizations commonly vary over a range of 10^3 or more and that the magnetization of most Earth materials is controlled by a few minerals which only occur as accessory constituents.
- Measurements of magnetic properties generally are made on samples extracted from the Earth, although under special conditions magnetic susceptibility can be measured *in situ* on outcrops. Magnetic susceptibility is measured by determining the effect of the sample on an induction bridge, and remanent magnetization, both direction and amplitude, is observed by measuring the effect of rotation of an oriented sample on a magnetic sensor.
- Magnetizations for purposes of geophysical exploration are determined per unit volume. The origin of magnetization in a few accessory minerals often leads to strong variability within rock units. Thus, care must be taken to insure that a representative suite of samples is measured in determining the magnetization of a subsurface unit.
- The magnetization of igneous and metamorphic rocks generally increases as their mafic content increases, as a result of an increasing proportion of magnetite and to a lesser extent other ferromagnetic and paramagnetic minerals. The remanent magnetizations of these rocks are low, commonly less than the induced magnetization. Volcanic rocks, particularly the more mafic volcanic rocks, are the exception: they carry a strong remanent magnetization as a result of their rapid cooling and fine-grained texture.
- Sediments and sedimentary rocks generally have negligible magnetizations because of very low contents of magnetic minerals. However, there are notable exceptions to this generality which reflect both primary detrital and chemically precipitated minerals and secondary ferromagnetic minerals due to post-depositional processes.
- The magnetization of soils may reflect their parent material where surface processes have not altered the constituent magnetic minerals, but surface layers may have an enhanced magnetization due to processes that control oxidation and reduction of their magnetic components. These include surface fires, fermentation associated with successive periods of oxidation and reduction, and microbial activity. Additionally, strong magnetizations can occur in surficial materials from the presence of fired clay that has acquired a thermal remanent magnetization, and ferrous objects with both induced and remanent magnetizations.

Supplementary material and Study Questions are available on the website www.cambridge.org/gravmag.

11 Magnetic data acquisition

11.1 Overview

The acquisition of magnetic data is relatively simple, rapid, and less complex than are the observations of data of most geophysical methods. Significant improvements continue to be made in magnetic instrumentation which facilitate accurate observation of the geomagnetic field on the Earth's surface as well as on a variety of airborne platforms, and from satellites of the Earth, Moon, and planets of the solar system. Most observations are made of the scalar, total intensity of the field, with alkali-vapor (resonance) magnetometers which readily achieve a sensitivity of better than a nanotesla with rates of several observations per second from a moving platform. These measurements are supplemented for special purposes by measurements of gradients, vectors, and tensors. Vector and tensor measurements are made with flux-gate magnetometers and increasingly with the highly sensitive superconducting quantum interference device magnetometers.

Surface or near-surface surveys are conducted on grids or parallel lines to map with high resolution the near-surface, local magnetic anomalies associated with a variety of archaeological, engineering, and environmental problems, but most magnetic surveys are conducted from a wide variety of airborne platforms. Although helicopter surveys may use outboard sensors placed in an aerodynamically stable housing at the end of a cable towed by the helicopter to place the sensor close to the surface to achieve the highest possible resolution, most airborne surveys use inboard sensors which require that extraneous magnetic effects of the aircraft are compensated by passive and active systems.

Surveys are flown along parallel lines separated by a few hundred meters to several kilometers at altitudes generally ranging from 150 m to several hundred meters. For geological mapping purposes the altitude is placed as low as can be flown safely, considering the topography and the flight characteristics of the aircraft, to improve the resolution of individual anomalies. To achieve this end most surveys are flown at a constant mean terrain clearance, although this procedure can lead to distortion of anomalies by magnetic terrain effects and major variations in the altitude of the aircraft above the surface as a result of limitations in the flight characteristics of the aircraft. Satellite observations of the Earth and extraterrestrial bodies are continuing to improve, providing useful information on planetary fields and, under special conditions, characteristics of the lithosphere.

11.2 Introduction

The acquisition of magnetic data is relatively simple and rapid compared with most geophysical observations. Furthermore, magnetic instrumentation is relatively inexpensive and easy to operate, and the planetary effects on

the magnetic observations are generally minor compared with the geological magnetic anomalies that are of interest in exploration surveys. The latter, which simplifies the reduction of magnetic data, is true if observations are not taken during periods of intense temporal variations of the geomagnetic field.

Prior to the late 1940s, magnetic surveying was conducted primarily with ground-based instrumentation which measured a vector component of the field to an accuracy approaching a few nanotesla with tripod-mounted mechanical balance magnetometers. This was satisfactory because the intensity of anomalies of interest was largely a few tens of nanotesla (nT) or more. Since then the availability of more precise and accurate electronic instruments which are insensitive to motion and orientation has led to rapid and efficient surveying on mobile platforms, especially from aircraft, with accuracies of the order of 1 nT (or 1γ) which is roughly 2×10^{-5} the surface geomagnetic field. More recently an accuracy of 0.1 nT is sometimes targeted in high-resolution surveys. These levels of accuracy are readily achieved by available instrumentation and can be approached in data reduction depending on the noise envelope of the observations. Minimization of the errors in surveys designed to map at these accuracies requires optimum instrumentation and exacting, but standardized, procedures for observing terrestrial magnetic fields.

Regional magnetic anomaly data covering most continental areas and large segments of the oceans have been assembled in commercial and governmental data repositories and into publicly available maps. However, the resolution and accuracy possible in current mapping of magnetic anomalies are usually not met in these public-domain data, requiring new surveys designed specifically for a particular exploration objective. These surveys involve mapping at the extremes of the magnetic anomaly spectrum: that is, near-surface, high-resolution surveys for anomalies small in size (often meters or a few tens of meters) and amplitude, which may involve magnetic gradient and tensor measurements; and, at the opposite end of the spectrum, satellite magnetic surveys which map scalar and vector components of very long wavelength anomalies of the order of 500 km or more. The potential higher resolution capabilities of magnetic anomalies over gravity anomalies from common sources is a major advantage of the magnetic method, but it also means that magnetic anomalies are smaller in size which requires significantly greater density of observations in the magnetic method. As a result care must be exercised in designing magnetic surveys to capitalize on their potential resolution.

11.3 Instrumentation

As mentioned in Section 8.3, a variety of techniques have been used to measure the angular relationships and magnitudes of the vector components of the Earth's magnetic field both absolutely and relatively. Prior to World War II magnetic surveys involved either pivoted needle instru-

ments or magnetic variometers. Hand-held needle instruments which measure anomalous fields with amplitudes in excess of several hundred nanotesla generally use a measurement of the oscillation or rest position of a counter-weighted magnetic needle pivoted on a horizontal axis either parallel (measuring the combination of the amplitude and dip of the Earth's field) or perpendicular (measuring the vertical component of the field) to the magnetic meridian. These instruments were largely restricted to mapping where the bedrock consisted of highly magnetic rocks, such as iron formations and volcanic rocks. Magnetic variometers measure either the deflection of a counter-balanced magnetic system that oscillates in the vertical plane perpendicular to magnetic north (e.g. the Schmidt-type variometer) or the force needed to bring an unoriented magnet system rotating in the magnetic meridian to a horizontal position (e.g. the torsion magnetometer (HAALCK, 1956)). Although magnetic variometers could reliably measure field changes approaching several nanotesla, they were slow and cumbersome to use because they required a tripod mount for leveling and, in some types, orientation. As a result they were replaced almost entirely by nuclear resonance magnetometers by the mid-1950s, with the vast majority of current magnetic surveying employing atomic resonance sensors.

Resonance magnetometers are scalar in nature, measuring the absolute total intensity of the magnetic field without consideration of the field's direction, and thus require no accurate orientation or leveling of the instrument. This is an important advantage that greatly increases their utility by making accurate observations possible on mobile platforms and explains their broad use in exploration magnetics. Nuclear or resonance magnetometers include the proton-precession, alkali-vapor, and Overhauser devices. They are used either alone to measure the total field or in pairs, involving a variety of configurations, to measure the total field gradient in various directions.

Another type of magnetometer is the flux-gate that was widely applied to observations on aircraft, ships, satellites, and other moving platforms for several decades. As the first airborne magnetometer, the flux-gate was originally designed and used to detect submarines during World War II. It is essentially a direction-dependent variometer that can measure either the vertical, horizontal, or total field and as such, even though largely replaced in airborne operations, has a role in measuring vector magnetic fields. Similarly, the high-sensitivity superconducting quantum interference device (SQUID) has an increasing role in exploration magnetics.

All modern magnetometers record digitally, and several have built-in provisions for mapping using GPS

surveying and displaying the surveyed observations. They have individual advantages and limitations which need to be considered when selecting an instrument for a particular survey.

11.3.1 Resonance magnetometers

Nuclear resonance magnetometers such as proton-precession, Overhauser, and alkali-vapor devices have sensors containing fluids or gases, with atomic properties that are sensitive to changes of the geomagnetic field. The operational principles of these devices are described below.

Proton-precession magnetometers

The proton free-precession magnetometer, which has an accuracy of the order of 0.1 to 1 nT, measures the precession frequency, the Larmor frequency, of protons in a hydrogen-rich fluid that have been oriented at a large angle to the geomagnetic field (\mathbf{B}_T) by a strong d.c. magnetic field (\mathbf{B}_p) originating from a current passing through a wire coil wound around the fluid container, the sensor (Figure 11.1(a)). Upon termination of the current through the coil and relaxation of the applied magnetic field along which the protons of hydrogen align (Figure 11.1(b.2)), the protons acting as tiny, spinning bar magnets precess around the ambient magnetic field (Figure 11.1(b.3)) at a frequency dependent on the intensity of the ambient magnetic field through a well-known constant, the gyromagnetic ratio of protons. The precessing protons induce a current in the surrounding wire coil which decays exponentially owing to thermal motions with loss of a coherent signal within a few seconds. The frequency of the induced signal due to the coherent precession of the protons is of the order of a few thousand hertz and is readily measured with a frequency counter (Figure 11.1(a)). The amplitude of the induced precession is directly dependent on the orientation of the axis of the sensor coil and the direction of the total field. No signal is received if the sensor axis and the field are parallel, and it is maximum with a right angle relationship between them. As a result the sensor requires crude orientation depending on the inclination of the geomagnetic field.

The proton-precession magnetometer, which was first suggested by the work of PACKARD and VARIAN (1954), has several advantages over previously used mechanical magnetic sensors and is readily produced as a robust, portable, and relatively inexpensive instrument. However, it does have disadvantages. Observations of the magnetic field are not continuous; rather, they require a finite period of time for orienting the protons by the current passing through the coil and for measuring the pre-

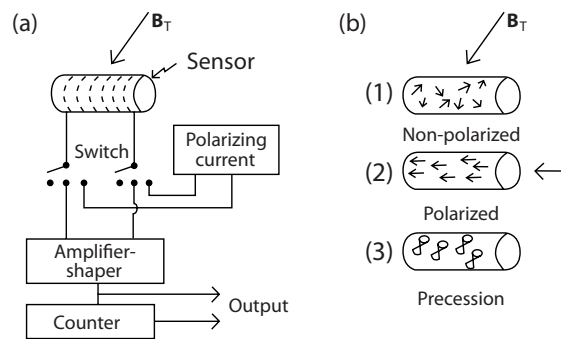

FIGURE 11.1 Simplified proton-precession magnetometer instrumentation with (a) the axis of the hydrogen-rich sensor oriented at a high angle to the magnetic field, \mathbf{B}_T . (b) Alignment of protons in the sensor in normal magnetic field (1), upon polarization by applied magnetic field along the axis of the sensor (2), and in precession mode (3) upon termination of applied axial magnetic field.

cession frequency. Decreasing the reading interval will decrease the sensitivity of the instrument. This is not a significant problem for static-mode land surface measurements, but may cause difficulties for measurements from a moving platform where a choice must be made between data interval and sensitivity. Furthermore, the proton-precession magnetometer is subject to erroneous observations caused by a.c. power interference and large magnetic gradients which produce an incoherent precession signal across the fluid container. Gradients of about 300 nT/m or more, which may occur near highly magnetic natural or man-made materials, will cause the instrument to give spurious readings. Errors may also result from rotation of the sensor during the counting period, especially in towed sensor systems. An additional disadvantage is the need for considerable power for the current to orient the protons along the axis of the sensor. As a result of these limitations the proton-precession magnetometer has been largely replaced for airborne measurement applications, as well as in surface surveying, by other resonance magnetometers.

Alkali-vapor magnetometers

Alkali-vapor or optical absorption magnetometers, which also measure absolute total magnetic field intensity, overcome some of the difficulties inherent in proton-precession sensors, and thus are the current instrumentation of choice in airborne magnetometry. Alkali-vapor sensors (Figure 11.2) are miniature atomic absorption instruments with a signal response proportional to the ambient magnetic field. They are capable of an order of magnitude greater sensitivity, have a shorter cycling time and thus

much higher sampling rate, and are tolerant of much higher magnetic gradients than proton-precession magnetometers. Accordingly, they have been used in specialized static observations requiring high sensitivity and in mobile platform applications.

These instruments operate by the principle of optical pumping, together with optical monitoring, that is used in radio-frequency spectroscopy. A beam of polarized radio-frequency light corresponding to a specific line in the alkali-vapor spectrum irradiates a cell containing an alkali vapor such as cesium, rubidium, potassium, or helium (Figure 11.2(a)). This causes the electrons in that energy level in the gas to be pumped to a higher energy level (Figure 11.2(b)) which is split into close magnetic (Zeeman) levels in the presence of a magnetic field such as the Earth's field where the light is absorbed. However, the electrons spontaneously decay to a lower energy state that cannot absorb light, and the cell becomes transparent, triggering a radio-frequency magnetic field that causes the electrons to shift to a state where the cell once again absorbs the light (Figure 11.2(b)). The frequency of the signal required to achieve transparency of the cell, the Larmor frequency, is a function of the ambient magnetic field and is much higher than the frequency involved in the proton-precession magnetometer. Thus, the magnetic field is measured by varying the radio-frequency signal and recording the frequency when the cell once again absorbs light.

Alkali-vapor magnetometers have an order of magnitude or more greater sensitivity than proton-precession magnetometers, with sensitivities reported to be in the range from 0.001 to 0.01 nT. Sampling intervals vary depending on the design of the instrument, but rates of up to 20/second (i.e. 20 Hz) are used. Unfortunately, optically pumped instruments have a small inherent heading error of roughly 1 nT and dead zones, in which the signal is lost, which are related to the orientation of the instrument with respect to the magnetic field. These problems have been largely overcome in commercial applications with a variety of methods including use of multi-celled sensor configurations, mechanical orientation of the sensor to maintain an optimum angle with the magnetic field, use of the split-beam cesium sensor (HARDWICK, 1984b), and use of a vapor which limits heading errors to less than 0.1 nT. The characteristics of this type of magnetometer can be modified somewhat depending on the alkali vapor used in the sensor cell, but all are much less sensitive than proton-precession instruments to errors due to high gradients. Current commercial magnetometers are available with cesium, potassium, or helium vapor as the sensor. Both potassium and helium have higher Larmor frequen-

cies, and thus have potentially higher sampling rates for a given sensitivity.

Overhauser magnetometers

The third type of resonance magnetometer is the Overhauser or spin-precession magnetometer (ACUÑA, 2002). This instrument is an enhanced proton-precession magnetometer that uses a wire-wrapped container filled by a special hydrogen-rich fluid with added paramagnetic ions (e.g. free unpaired electrons) as its sensor. It derives its name from the Overhauser effect which describes the transfer of spin energy of orbital electrons to the protons of hydrogen atoms in a fluid that contains a special dissolved salt (OVERHAUSER, 1953).

A radio-frequency electromagnetic field excites the system rather than a discrete polarizing pulse. The very high-frequency electromagnetic resonance of the paramagnetic ions causes the protons to precess continuously for a nearly continuous sampling of the magnetic field's variations at rates up to 5 Hz or sometimes more. Relative to the standard proton-precession magnetometer, the Overhauser device requires less power and measures nearly continuous field variations at greater sensitivities (0.1 to 0.01 nT) with 100–1,000 times the strength of the discrete signal, and hence has a very broad operating range. Thus, Overhauser measurements have significantly improved signal-to-noise and reduced measurement uncertainties. In addition, the Overhauser instruments are without heading error or dead zones where they are inoperative.

11.3.2 Flux-gate magnetometers

In specialized applications of the magnetic method, it may be desirable to obtain the directional attributes as well as the total magnitude of the magnetic field (see Section 11.3.5). The scalar intensity of the field is determined by resonance-type magnetometers, but flux-gate magnetometers are used to measure vector components of the field. The flux-gate instrument, which is no longer regularly used for measuring the total field variations in airborne magnetometry, measures only the relative change, not the absolute value, of the geomagnetic field and is directionally dependent.

Construction details vary among flux-gate instruments, but, in the classical design, this magnetometer consists of a pair of identical, but oppositely wound inductive coils with cores of the same high magnetic permeability material along their axes (e.g. cores A and B in Figure 11.3). The cores are magnetized to saturation by the induced fields from an alternating current passed through the windings of the coils in opposite directions. In the

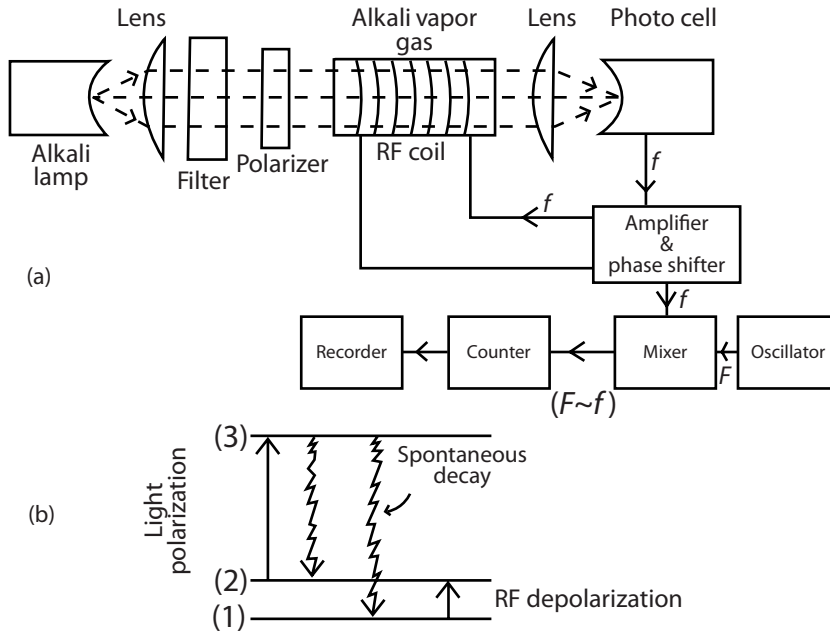

FIGURE 11.2 (a) Schematic diagram of a self-oscillating alkali-vapor magnetometer. (b) Schematic illustration of alkali metal energy levels used in the alkali-vapor magnetometer. Spontaneous decay of unstable electrons of an alkali metal and excitation of electrons from level 2 to 3 only by light polarization of a specific wavelength leads to a fully depopulated level 2. In this state the vapor cell stops absorbing the alkali-vapor light and becomes transparent to the light. Unstable electrons in level 3 decay to levels 1 and 2, eventually causing a full population of level 1 and depopulation of level 2. The unit detects the fluctuation of light intensity as the cell moves from transparent to opaque with the change in population levels and measures the frequency of the corresponding depolarization field. The radio-frequency (RF) depolarization field moves electrons from level 1 back to level 2 at a frequency directly proportional to the ambient magnetic field. Adapted from HOOD and WARD (1969).

absence of an ambient magnetic field \mathbf{B}_T , there will be no difference in the induced fields of the cores other than polarity in the voltages induced in the secondary coils wound around the induction coils. This is true only where the magnetic properties of the cores are equivalent. However, as illustrated in Figure 11.3(b), a static magnetic field \mathbf{B}_T in the direction of the cores will reinforce the magnetization in one core, causing it to reach saturation first, and oppose it in the oppositely wound induction coil to shift the phases of the two secondary coil induced fields \mathbf{B}_A and \mathbf{B}_B so that the resulting coil voltages V_A and V_B sum as alternating positive and negative voltage spikes. The sum of these voltages is proportional to the intensity of the magnetic field in the direction of the sensors (Figure 11.3(a)) and can be determined by nulling the voltage with a current in the secondary coil calibrated in terms of the ambient magnetic field. A d.c. bias resistor is placed across one of the cores' elements (Figure 11.3(a)) which unbalances the circuit producing voltage pulses of equal intensity in the presence of a zero magnetic flux, preventing drift of the readings with time. More recent versions of these magnetometers use only the

prominent second harmonic component of the unbalanced voltage.

Three mutually perpendicular elements appropriately oriented can measure the individual vector components of the field, and thus their angular relationships and by calculation the total field intensity. Sensitivities of flux-gate magnetometers are usually about 1 nT up to the order of 0.1 nT, in specially constructed instruments. A wide variety of alternative designs of the flux-gate magnetometer have been developed including the cylindrical core flux-gate and the ring-core design which has found considerable use in space measurements because of its low mass and simplicity. These and the history of vector magnetic measurements in space are described by R. C. Snare in the website <http://www-ssc.igpp.ucla.edu/aersonnel/russel/ESS265/history.html>.

Airborne flux-gate magnetometers, which were the first to measure the crustal fields from moving platforms, generally measure the total magnetic field to minimize problems in orienting the sensor to measure the field to a sensitivity required for magnetic exploration. The axis of the flux-gate element is accurately aligned in the direction

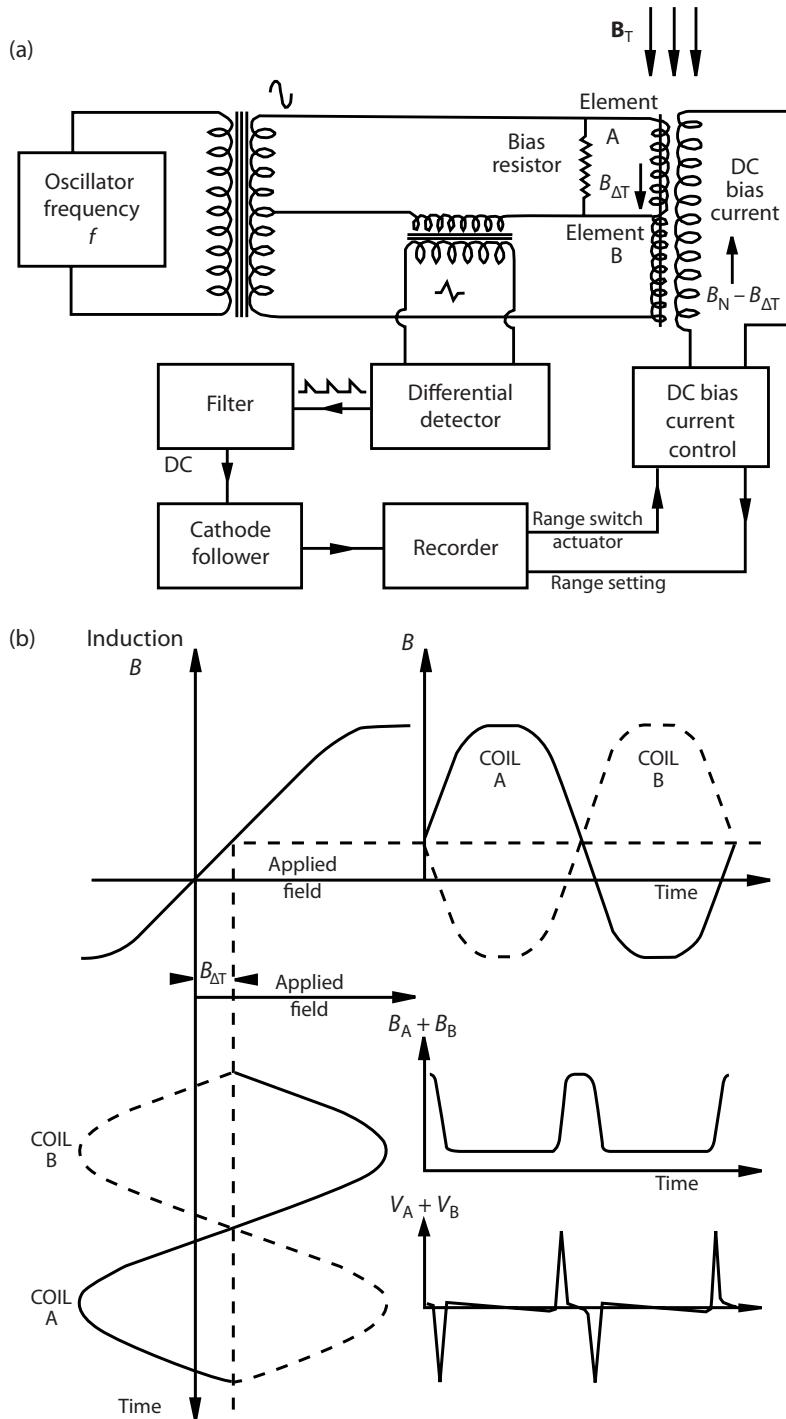

FIGURE 11.3 (a) Basic circuit of a peak voltage flux-gate magnetometer. The sensor consists of two identical high magnetic permeability ferromagnetic cores within identical, but oppositely wound inductive coils (elements A and B). (b) Illustration of the effect of the ambient magnetic total field B_T on the magnetic saturation of the ferromagnetic cores by the applied field which causes a shift in the phase of the current induced in the secondary coil. The resulting voltages V_A and V_B sum as alternating positive and negative voltage spikes. The sum of these voltages is proportional to the intensity of the ambient magnetic field in the direction of the elements. Adapted from HOOD and WARD (1969).

of the Earth's magnetic field for measurement using a three-axis movable platform in which the outputs of the supplemental orthogonal elements are used to position the primary element for sensing the total field. The supplemental elements are driven to a position of zero field by a servo-motor feedback system, thus placing the primary sensor accurately in the direction of the geomagnetic field. Handheld flux-gate magnetometers can measure the vertical field by orienting the sensor with a gimbal pendulum assembly. Three orthogonal component flux-gate magnetometers with sensitivities of 0.1 nT are used in directional magnetic mapping in drill holes where orientation of the sensors is achieved gyroscopically and inclinometers are used to determine the tilt of the sensor probe (e.g. BOSUM *et al.*, 1988; MORRIS *et al.*, 1995). Alkali-vapor total field intensity magnetometers are used also in drill holes, even in shallow drill holes for the purpose of detecting ferrous metals, but they lack the directional sensitivity that is possible with three-component flux-gate magnetometers.

11.3.3 SQUID magnetometers

The most sensitive magnetometer available for exploration is the superconducting quantum interference device or SQUID, which is sometimes called the cryogenic magnetometer because it uses measurements associated with superconducting metals and alloys which require very low temperatures, that is cryogenic temperatures (below -150°C). The need to maintain the sensor at cryogenic temperatures is an obvious disadvantage, but this problem has been relieved to some extent by the use of liquid nitrogen (-196°C) as the coolant in recently developed SQUIDs rather than the lower-temperature liquid helium that was previously used. As a result current instruments are smaller and more portable than those of a decade or more ago.

An explanation of the working principle of this instrument is more complex than nuclear resonance magnetometers because of the need to deal with the wave-mechanical nature of electrons and superconductivity. However, the instrument itself is rather simple (e.g. ZIMMERMAN and CAMPBELL, 1975; WEINSTOCK and OVERTON, 1981) consisting of a superconducting loop which is weakened at one or two places by point contacts known as Josephson junctions. These junctions serve to amplify the current induced in the loop. This current periodically exceeds the critical current at which the loop takes on a finite electrical resistance, in contrast to the zero resistance of the normal superconductivity state. As a result a voltage appears in the loop that is a measure of the external magnetic field perpendicular to the loop. A negative

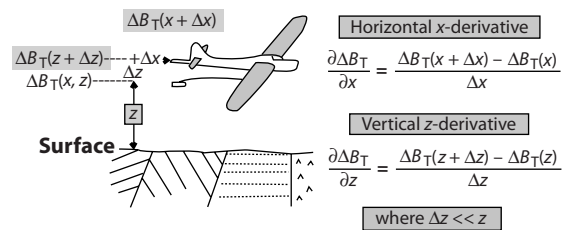

FIGURE 11.4 Measuring the first vertical and horizontal derivatives of the total intensity of the Earth's magnetic field.

feedback circuit is used to detect the voltage and null the field. The output of this circuit is a measure of the field cutting the loop which can be determined to a sensitivity of the order of 10^{-5} nT. Thus, SQUIDs are very sensitive vector magnetometers, which with appropriate combinations of superconducting loops can be used to measure magnetic gradients.

Several different types of SQUIDs have been developed for measuring the geomagnetic field and its gradients. The high sensitivity of SQUIDs makes them particularly useful in measuring gradients. As a result they have been used successfully with multiple sensors to observe the full tensor (gradients of the three mutually perpendicular vector components) of the magnetic field (e.g. SCHMIDT *et al.*, 2004) including measurements of magnetic tensors from aircraft (STOLZ *et al.*, 2006).

11.3.4 Magnetic gradiometers

Magnetic gradiometers are simply two magnetic sensors, either scalar or vector, separated by a fixed distance with the measurements made simultaneously in both and compared for the observation (Figure 11.4). As in the gravity method, measurement of magnetic gradients offers several advantages over amplitude field observations (SCHMIDT and CLARK, 2006) that include minimizing regional effects, increasing anomaly resolution, and eliminating temporal magnetic variations. Taking advantage of these attributes, surface gradients have been used for decades in shallow zone studies in association with archaeological investigations and the detection of ferrous objects such as land mines and ordnance. They are also being used increasingly in airborne and marine studies for petroleum and mineral exploration. This is facilitated by modern magnetic instrumentation which allows efficient observation of fields at the close spacing required to measure the short wavelengths of gradients.

Although horizontal gradients are used occasionally, vertical gradient measurements are particularly useful in improving the resolution. Interest in gradients is

increasing because of their use in determining the full tensor of the magnetic field which offers interpretational and acquisition advantages over the simple scalar field usually measured (SCHMIDT and CLARK, 2006). Additionally, WOOLRIDGE (2004) notes that gradient measurements can be used to level magnetic field data without tie lines using generalized 3D Hilbert transforms. They also improve gridding using the lateral gradient as a constraint.

Vertical gradient measurements may be made using a single magnetometer with observations at two levels or, more commonly and more efficiently, with the simultaneous use of two magnetic sensors fixed at a constant vertical separation of the order of a meter or two. Vertical gradients of the geomagnetic field are of the order of 0.5 nT/30 m, but crustal vertical magnetic gradients are commonly 10 nT or more per 30 m. As a result where the magnetic gradient is measured as the difference between two vertically separated magnetometers, high sensitivity instrumentation and minimal errors are needed (HARDWICK, 1984a). HOOD *et al.* (1979) showed that a magnetometer sensitivity of at least 0.01 nT is required for airborne mapping of vertical gradients with a 2 m sensor separation in crystalline bedrock terranes. As a result of these sensitivity requirements, the high-sensitivity SQUID magnetometer is especially suited for gradient measurements, although other resonance magnetometers which measure the total magnetic field have been extensively used for this purpose, especially in crystalline bedrock terranes and in the exploration for ferrous objects in the near surface where the anomaly gradients are relatively high (e.g. BILLINGS and WRIGHT, 2009).

Alternatively, it is possible to compute the vertical gradient of the total magnetic field from observations of the total field at one level providing that the field is fully sampled. This can never be done completely accurately, but with high-density observation coverage, it can be approximated. For example, ROBERTS *et al.* (1990) and BILLINGS and WRIGHT (2009) show a near equivalence of observed and calculated vertical gradients where the data density at a single elevation is sufficient to approximate the field at that level. However, calculated gradients do not eliminate the effect of temporal magnetic variations as do measured gradients, a significant advantage of measured gradients.

11.3.5 Vector versus scalar magnetic measurements

Before the mid-1940s, essentially all exploration magnetic observations were vector components, primarily the ver-

tical magnetic anomaly field. However, since the advent of the airborne flux-gate and resonance magnetometers, essentially all exploration magnetic observations have been made of the scalar field. It was realized that the total magnetic anomaly field is in error because the amplitude of the total geomagnetic field is subtracted in a scalar sense from the observed field to determine the anomaly regardless of the orientation of these components. Nonetheless, as shown previously in Table 8.3 the error is minor for most crustal magnetic anomalies and only approaches 10% as the anomalies exceed 10,000 nT. As a result the scalar total magnetic intensity has been and continues to be the acceptable magnetic anomaly component for exploration purposes.

Despite the universal acceptance of the scalar component in exploration, interest continues in measuring vector components and their gradients as either a replacement for or supplement to total field measurements. It is of course possible to calculate the vector components from the total field in a variety of ways (e.g. PURUCKER, 1990), but limited sampling of the total field restricts the accuracy of these calculations. As a result measurements of the vector components of the geomagnetic field continue to be made with either flux-gate or SQUID magnetometers. Vector measurements are made in satellite surveying to identify fields derived from the ionosphere and meridional currents (MAEDA *et al.*, 1982; RAVAT *et al.*, 1995). Also, slight differences between observed vector data and those computed from scalar data have been used to identify strong remanent magnetization in crustal anomaly sources (GIRDLER *et al.*, 1992; TAYLOR and RAVAT, 1995; PURUCKER and WONIK, 1997; LANGEL and HINZE, 1998). In addition, a joint inversion of vector and scalar components has been used to stabilize and improve the interpretation of magnetic anomaly data (PURUCKER, 1990; LI and OLDENBURG, 2000).

Vector magnetic measurements have also been used by BLAKELY *et al.* (1973) to distinguish 2- from 3D magnetic anomaly sources and detect off-track sources in mapping marine magnetic stripes. They found that the magnetic component parallel to the magnetic stripes observed only anomalies from 3D sources and not the 2D magnetic stripe anomalies. In addition, gradients of vector components are finding increasing application in both mineral and petroleum exploration. SCHMIDT and CLARK (2006) have reviewed the properties of the magnetic gradient tensor and outlined their merits. The tensor combines the advantages of gradient as well as vector component measurements in improving resolution and interpretation as well as minimizing errors in the data acquisition.

11.4 Survey design and procedures

Magnetic observations are made in drill holes, mines and tunnels, and on the terrestrial surface, as well as from submarine, ship, airborne (≤ 20 km), balloon (≤ 40 km), and satellite (≥ 150 km) platforms. Magnetic measurements close to the surface are the norm in near-surface geophysical studies because of their higher resolution than airborne observations. However, airborne measurements are particularly efficient and useful in studies of extensive areas, especially in regions where surface access is problematic. Drillhole measurements are made with specialized instrumentation using either directional magnetometers or total field instruments. Directional measurements in bore-holes require more sophisticated instrumentation because of the need for orientation of the sensors, but they can be powerful tools to pinpoint the location of buried magnetic sources with a high degree of resolution. Survey design of and procedures for drillhole measurements are similar to those of near-surface measurements. Satellite magnetic observations have taken on an increasing role in studying the main geomagnetic field and its variations and, in specialized cases, mapping regional lithospheric magnetic sources.

The design of a survey and the procedures used in data acquisition are determined by factors including the objectives of the survey, the size, location, and physical characteristics of the study area, the anticipated sources and nature of magnetic anomalies and noise, and the resources available. In several respects the process is similar to that described in Section 5.4 for the gravity method. However, fundamental differences do exist because of the dipolar nature of the magnetic field, the sources of magnetic anomalies and noise, and the measurement principles. For example, the size of the area of a survey or the length of an observation profile depends primarily on the maximum depth of the anticipated sources and the nature of the regional anomalies. The source depth controls the extent of the anomaly, and the coverage must be sufficiently extended and dense to permit isolation of the target anomaly from regional anomalies derived from broader, deeper geological sources. The interference of regional with local anomalies is much greater in gravity than in magnetics because magnetic anomalies have a significantly smaller extent than do gravity anomalies from the same source. As a result, the coverage required in magnetic surveys is less extended, but greater data density is required than in gravity surveying.

A common assumption in magnetic surveying is that the coverage should extend beyond the limits of the area of interest for a minimum distance equal to the maximum



FIGURE 11.5 The layout of ground surveys involves making appropriate choices of the magnetometer, survey altitude, and grid spacing, as in this example from an archaeomagnetic survey that uses a proton-precession magnetometer at 0.5 m above the ground surface at a station grid interval of 1.5 m.

depth of the target sources. The spacing between measurements should not exceed the minimum depth of the target sources. This is based on the generality that the anomaly from a concentrated source decreases to 10% of its maximum amplitude at a distance equivalent to the depth to the center of a concentrated magnetic source, and contrasts with the three-fold greater width for the gravity anomaly from a similar source. The coverage suggested by this generality should be considered minimum, especially where regional anomalies are dominant and complex and the sources have a vertical extent of several times the depth to their top surfaces.

11.4.1 Land surface surveys

Surface (or near-surface) surveying involves obtaining magnetic observations at appropriate accuracies, intervals and resolution to map the effective signatures of the subsurface targets or sources of interest (Figure 11.5). Observations commonly are made at specified locations using handheld instruments with the sensor located at the top of a staff of a half a meter or more above the ground surface to minimize the effects from local variations in the magnetization of the soil and magnetic fields derived from currents induced in electrically conductive soils from fields originating within the magnetometer. Stations are either organized on a grid pattern or, in mapping linear patterns of anomalies, on parallel traverses perpendicular to the anticipated anomaly strike. The separation between traverses depends on the continuity of the linear anomalies and the detail required for the purposes of the survey, but traverses generally can be placed at a distance

of several times the station interval without encountering problems in mapping anomalies. Grids usually are orthogonal with the directions controlled by local surface conditions or placed parallel and perpendicular to magnetic north.

The grid interval or the station spacing along traverses depends on the objective of the survey. If the survey is intended to only detect the presence of anomalies, the intervals can be large with only one or two observations that occur within the area of the anomaly. The dimension of the anomaly above any prescribed magnetic noise level can be determined by calculating the anomaly from the characteristics of the target anomaly source and the nature of the ambient terrestrial magnetic field. However, the noise characteristics may be difficult to establish beforehand, so it is desirable to conduct the survey in a manner that will minimize the effects of the various sources of magnetic noise. A general rule is that the station interval should not be greater than the minimal depth of the sources, assuming that they are concentrated or linear-concentrated sources. This generality suggests that at least one station will be within the area or length in which the anomaly exceeds 50% of its maximum amplitude.

A station interval equal to the depth is not adequate for mapping anomalies for analysis and modeling. For these purposes the highest horizontal gradients that are anticipated should be mapped. As a generality, assuming a concentrated or a linear-concentrated source, a station interval of 0.2 of the depth to the center of the source will map the highest gradients and the amplitude of the anomaly within 10% of its maximum value. As the depth extent of the source increases, the appropriate station spacing may increase from this generality.

As explained in Chapter 10, there are numerous sources of magnetization, both natural and anthropogenic, in the subsurface. In some surveys, these are the objective of the mapping, but in others they distort the magnetic anomalies derived from deeper, larger sources. Many sources are equidimensional and, although intensely magnetic, produce anomalies that decrease rapidly with distance. Near-surface effects can be minimized in the magnetic observations by increasing the height of the sensor above the ground surface. The presence of localized, near-surface sources can be detected by making several observations over a short time period measured in minutes within a limited area at significantly smaller intervals than the station spacing of the survey. The average value of these measurements can be used as representative of the station, but if the variations are considerably greater than anticipated from the anomalies derived from the target sources, the station should be eliminated from the survey. Of course,

care must be used to avoid obvious magnetic effects from ferrous objects and electrical fields either on the instrument operator or in the vicinity of the station. The required separation between observations and potential sources of noise depends on the source and shape of the extraneous source, its orientation in the terrestrial magnetic field, and the survey requirements. Distances of 50 to 150 m are desirable from ferrous objects and a few hundred meters from power lines. Extreme examples of cultural effects which produce surface magnetic anomalies of hundreds of nanoteslas or more are cathodically protected pipelines and in-place drillhole casings.

Specific situations may dictate the need to acquire high-resolution, near-surface survey data over extensive regions involving hundreds or thousands of observations. To minimize the time and costs involved in surveys of this size, magnetometers have been mounted on various types of transport including motor vehicles, bicycles, balloons, helicopters, small remote-controlled unmanned aircraft, and horses. These are most effective if the magnetometer automatically makes observations at a prescribed time or distance interval and is tied to a GPS mapping system that locates the geographic position of each measurement. All of these observations including the time of each measurement are digitally recorded and downloaded on a daily basis to a computer for data storage, processing, and presentation. For accurate observations, care must be used to isolate the sensor from the magnetic fields associated with the transport or compensate for these fields. Similar procedures are used for shipborne surveys of water-covered regions. In these cases the magnetic sensor is normally trailed behind the vessel in a streamlined container to avoid the vessel's magnetic effects.

An important consideration in the design of a magnetic survey is the procedure that will be used to monitor the temporal variations in the magnetic field caused primarily by the interaction of electromagnetic and corpuscular radiation from the Sun with the Earth's ionosphere and by tidal forces acting upon the ionosphere. As discussed in Section 8.3.4, these fields, which are of sufficient intensity to interfere with precise magnetic mapping of geologic sources, are notably unpredictable, preventing their modeling on theoretical grounds. Accordingly, the magnetic field is monitored either by reoccupation of a base station or by a base magnetometer that periodically measures the ambient magnetic field. The latter is the preferable approach, but requires a separate, special instrument and a secure location for the magnetometer, preferably within several tens of kilometers of the survey area. These instruments include precise timing and a reference time base for correlation with the recorded time of the

field observations. Repeated observations with these stationary magnetometers are typically measured in minutes for most mapping purposes. Base-station magnetometers need to be placed in locations that are remote from ferrous or highly electrically conducting materials, including rocks, sources of direct electrical current, and instrumentation that involves switching of intense alternating electrical fields. They are a feasible method of monitoring temporal variations in magnetic fields because the inherent drift of modern magnetometers, unlike gravimeters, is negligible considering the sensitivity of the instruments. However, it is prudent to supplement the base magnetometer observations with reoccupations of a base station to insure that the magnetometers are operating correctly. Real or virtual reoccupation of base stations is an alternative method of monitoring the temporal variations in the magnetic field. The siting of magnetic base stations is particularly important. Care must be used to avoid high gradient and anomalous magnetic background levels and local fields from ferrous materials and electrical currents, including variable effects from traffic on nearby roadways. These stations must be well described and easily recognized so that reoccupations will be in precisely the same location.

The time interval between reoccupations is a function of the variability of the magnetic field, both its gradient and amplitude, and the requirements of the survey. During magnetic quiet times, especially at night, the variation in the magnetic field generally is less than 10 nT/hour, and thus can readily be monitored at hour-long intervals with the assumption of linear variation between observations. However, during magnetic storm periods when the Earth is exposed to intense bombardment by corpuscular radiation from the Sun, the fluctuations of the magnetic field may reach several 100 nT over intervals measured in minutes. During these periods, it is impossible to monitor by either a base magnetometer or station reoccupation the variations to a precision that permits accurate spatial mapping of the terrestrial magnetic field. Generally, it is advisable to reoccupy the base station at least at the beginning and end of the day when monitoring the magnetic variations with a base magnetometer and on a semi-hourly basis when using the reoccupations for monitoring of the field. However, this may vary depending on numerous factors including the magnetic latitude, the state of the terrestrial field, and the requirements of the survey.

More intense and variable magnetic fields are anticipated within roughly five degrees of the magnetic equator owing to the equatorial electrojet and at magnetic latitudes of from 60° to 80° in the auroral regions. During extended magnetic surveying periods, it is advisable to

monitor forecasts of the occurrence of magnetic storms made by national geophysical agencies, thus avoiding surveying during periods of rapid and intense magnetic field variations. The variation in the magnetic field, either measured or predicted, is often described by magnetic indices which are discussed in Chapter 12.

11.4.2 Marine surveys

Marine magnetic surveys have produced much of the evidence for plate tectonics and facilitated the exploration of the seafloor for mineral and energy resources, as well as archaeological, engineering, and military applications. These surveys are typically conducted by towing a water-tight, aquadynamically stable housing or fish that contains the magnetometer's sensor.

To avoid the ship's magnetic effects, the fish is towed roughly 3 m below the surface at several ship lengths on a cable that includes electrical conductors to power and operate the sensor. Typically, the sensor consists of an alkali-vapor magnetometer, but various types and configurations of magnetometers are employed to measure gradients as well as vector components which are used to facilitate identification of anomalies and removal of extraneous components (e.g. ENGELS *et al.*, 2008). In addition, surveys may be made close to the ocean bottom to improve the resolution of the observations. The survey tracks are typically perpendicular to the magnetic or structural fabric of the seafloor. The track spacing is generally dictated by the minimum magnetic source depth which is commonly taken as the water depth. Seafloor depths typically range over 2–6 km so that track spacings of 2–10 km are normally sufficient for most oceanic geology applications. However, marine magnetic surveying is often a secondary component of bathymetric, gravity, seismic, or other geophysical/oceanographic surveys that accordingly dictate the spacing and direction of the magnetic data tracks.

Temporal variations in the geomagnetic field may be checked from the records of nearby geomagnetic observatories or base stations anchored to the seafloor within the survey area with time synchronization between the marine sensor and the base magnetometer preferably to the nearest second. However, the need for magnetic base observations is eliminated when surveying with magnetic gradiometers. In general, the major source of error in modern marine magnetic surveys is the quality of the control on the temporal variation in the field. Prior to the availability of GPS data in the mid-1980s, navigation errors contributed the principal uncertainties in marine magnetic data.

11.4.3 Airborne surveys

Airborne magnetic surveying is preferred for most geophysical applications except for those requiring the highest resolution of anomaly sources. Airborne surveying is economical, rapid, and efficient in studying extensive regions and minimizes the effects from cultural features, temporal variations, and near-surface geologic sources. However, these advantages are achieved only with great care in planning and conducting the survey. Numerous journal, contractor, and governmental publications describe the advances in airborne magnetic surveys since the first surveys for geological purposes in the 1940s. Particularly useful is the report of the Geological Survey of Canada on aeromagnetic specifications and contracts (Aeromagnetic Standards Committee, 1991) and the more recent web-based books by REEVES (2005) and REEVES and BULLOCK (2005).

Objectives

The design and conduct of aeromagnetic surveys is very much dependent on the objectives of the project. Generally, objectives can be defined as reconnaissance, regional, or detailed (Aeromagnetic Standards Committee, 1991). Reconnaissance surveys are those with widely spaced flight paths that are conducted to obtain broad tectonic and geologic characteristics of an extensive region at a minimum of cost. They are often used to map selected characteristics of a region to isolate limited areas for more extensive study: for example, faulted regions, areas of deep basement, or volcanic terranes may be identified. Flight line spacings typically are a kilometer or more and the altitude of the surveys less than the flight line spacing depending on the specific survey objectives. Many nationwide surveys belong to this category.

Regional surveys provide a more comprehensive and detail view of the geology and tectonics of a region than reconnaissance surveys. Often they are used in geological mapping at scales of the order of 1:100,000 based on measurements at altitudes of a few to several hundred meters and line spacing/flight altitude ratios of 1.5 to 5.0. They too are used to select regions for more detailed, high-resolution study based on attributes of special interest such as intrusive contacts, alteration zones, and basin structures. These detailed surveys are flown as close to the source of anomalies as possible. Safety concerns for surveys where the sources are close to the surface generally limit the flight altitudes to several tens of meters and use flight altitude/line spacing ratios of 2 to 1.

Aircraft

An important part of designing an aeromagnetic survey is the selection of the appropriate aircraft. Surveys have been flown with every conceivable aircraft from small, low-power aircraft to wide-ranging four-engine planes, as well as helicopters (Figure 11.6) and lighter-than-air platforms. The selection of a survey aircraft is a trade-off among numerous factors including the flight duration, speed, stability, cost effectiveness, distance of survey from airports, instrumentation, the terrain of the region, and the required power characteristics of the aircraft. The latter is especially important where the flight altitude is established as constant above mean terrain to achieve high resolution and consistency in altitude above magnetic sources that are close to the surface.

In rugged terrain where the topography is steep and surface elevations vary in excess of a few tens of meters, a low-powered aircraft cannot safely maintain a constant elevation above the surface. Typically flights in these terranes are too low above topographic highs and too high above topographic gradients because of safety considerations. Furthermore, these altitude deviations may vary depending on the direction of the aircraft. These altitude variations introduce changes in the magnetic measurements that are unrelated to magnetic sources and are difficult to remove from the observations. In addition, where flight direction is a factor in determining the safe altitude of the aircraft, abnormal changes in the magnetic measurements may vary from line to line. As a result of these problems every effort is made to insure the safety of the aircraft while maintaining as much as possible the design specifications of the survey. This necessitates close coordination between survey specifications and the aircraft flight characteristics in selecting the appropriate aircraft (COWAN and COOPER, 2003).

Flight specifications

Observations are made along parallel flight lines generally directed perpendicular to the strike of the prevailing magnetic anomalies or, where there is no dominant strike to the anomalies, in a direction that will facilitate the surveying procedure. For example, the flight lines may be oriented to take into consideration the terrain in the survey area and the need to maintain a constant flight height above the surface. If not observed in a particular direction for a compelling geologic reason, it is advantageous from an interpretational point of view at high geomagnetic inclinations ($\geq 70^\circ$) to fly north-south tracks so as to map the full dipolar effect of anomalies including both the positive and negative components of the anomaly. Similarly, at low geomagnetic inclinations ($\leq 25^\circ$), east-west flight

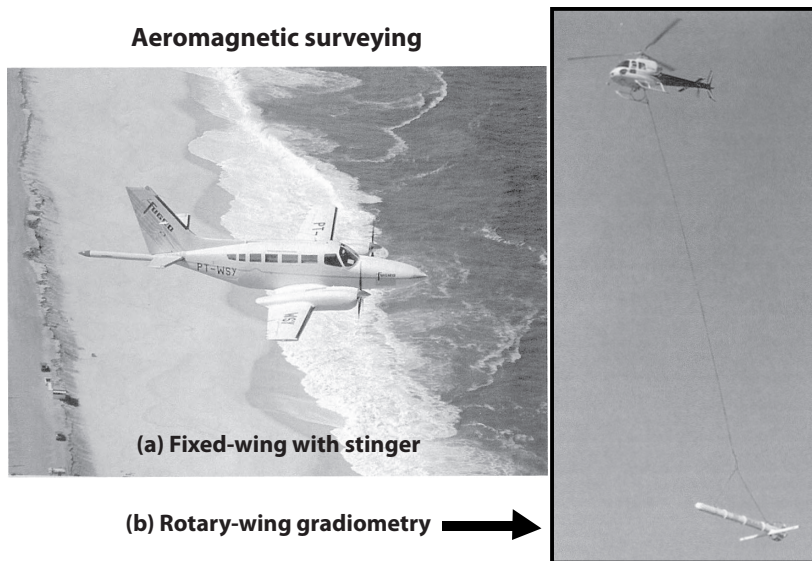

FIGURE 11.6 Airborne magnetic surveys commonly deploy magnetometers on (a) fixed-wing or (b) rotary-wing aircraft. In (a), the magnetometer is housed in the tail stinger to map total field anomalies. In (b), the vertical and horizontal magnetic gradiometer is suspended by cable from the helicopter. Courtesy of Fugro, Inc.

lines have limited significance because of the absence of magnetic anomalies from north–south striking anomalies near the equator (LILLEY, 1968). For most exploration purposes it is desirable to conduct surveys north–south or within about 30° of the perpendicular to the prevailing strike of the anomalies. In mapping large regions that have marked changes in the strike of the anomalies, it may be necessary to break the region into blocks with different flight directions to maintain an appropriate flight direction.

The spacing of the traverses depends on the objective of the survey and the depth to the magnetic sources. REID (1980) showed that to avoid aliasing errors in the data which will deteriorate the identification of anomalies and their interpretation, flight lines should have a maximum spacing of twice the depth to the target sources and that this should be decreased to the depth of the sources for comprehensive analysis and modeling of the data. Figure 11.7 shows four total field magnetic anomaly maps over the Marmora magnetic anomaly in southern Ontario, Canada, based on flight line spacings of 1, $\frac{3}{4}$, $\frac{1}{2}$, and $\frac{1}{4}$ miles along north–south flight lines observed at 500 feet above the ground surface (AGOCs, 1955). The $\frac{1}{4}$ mile line spacing provides a much improved resolution of the anomaly over the other maps, but even this map is significantly aliased because the depth to the source of the anomaly is 600–700 feet below the observation level,

indicating that at a minimum the flight lines should be of the order of $\frac{1}{8}$ mile.

Gradient measurements are generally applied to detailed surveys, and thus require a minimum spacing of the depth to the sources. The spacing of flight lines is constant over a survey or a survey block so as to achieve consistency in magnetic patterns over similar geology. However, in reconnaissance surveying, banded flight tracks may be used as a cost-saving measure. In these surveys groups of two or three flight tracks, a band, are measured at a closer separation than the flight track separation between a much larger number of intervening survey lines. The closer flight line spacing in the bands provides for more detailed interpretation and definition of the strike of the magnetic anomalies, yet a broad region can be covered and studied for selecting limited regions for more detailed analysis in an economical manner. Another flight line pattern variation is to establish an orthogonal grid of flight lines. This pattern has been used in some detailed studies especially where the target magnetic anomalies do not have a consistent strike, but generally, considering the additional cost, the extra magnetic observations of the orthogonal grid are unwarranted.

The sampling interval along the flight lines can be synchronized to a range of distances along the track or time-interval depending on the resolution requirements of the survey and the speed of the aircraft. Generally, several

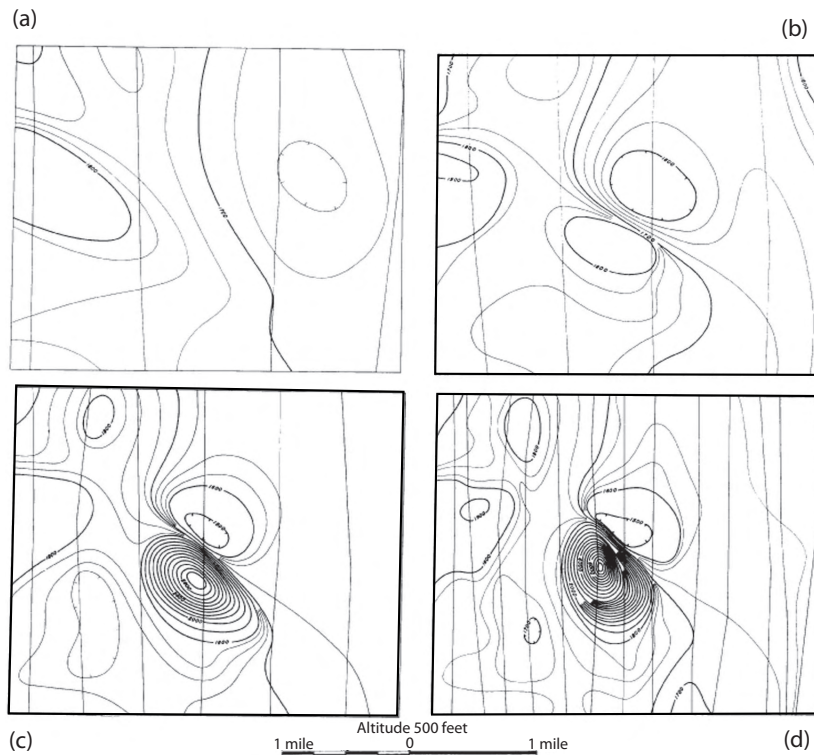

FIGURE 11.7 Comparison of total field magnetic anomaly maps observed over the Marmora magnetic anomaly of southern Ontario, Canada at an elevation of 500 feet with flight line spacings of (a) 1 mile, (b) $\frac{3}{4}$ mile, (c) $\frac{1}{2}$ mile, and (d) $\frac{1}{4}$ mile. Note the much better definition of the anomaly at decreasing flight line separation. Adapted from AGOCs (1955).

observations are made per second, resulting in a separation between observations of the order of a few tens of meters, although smaller intervals are possible depending on the instrumentation and speed of the aircraft and the survey objective.

The altitude of the surveying is dictated by several factors including the objectives of the survey, the geology including the depth and depth extent of the sources, the surface relief, flight safety considerations, and the presence of cultural features. However, the principal concern in most surveys is anomaly resolution, thus the flight altitude is made as low as possible commensurate with safety considerations. Typically, for geological mapping this is an altitude of 150 m with a constant mean terrain clearance to achieve maximum resolution, but by using helicopters for surveying the altitude can be decreased. In some surveys the altitude can be lowered to only a few meters in flat terrain to achieve maximum resolution for engineering and environmental purposes. A useful generality is that the altitude is roughly equivalent to the minimum separation of features which can be resolved. The term “mean” is used to acknowledge that aircraft cannot actually main-

tain a constant altitude above terrain because of flight safety and limitations in maneuverability. Concern has been raised about interpreting data obtained from a mean terrain clearance flight mode in terranes where the surface rocks are magnetic because of the impact of magnetic terrain effects on the interpretation of the data and the difficulty in accurately determining these effects (GRAUCH and CAMPBELL, 1984; REFORD, 1984; UGALDE and MORRIS, 2008).

An alternative to flights at a constant terrain clearance is a survey which is loosely draped over the surface so as to achieve maximum resolution while minimizing magnetic terrain effects and the variations in the flight surface. In modern surveys, flights can be pre-planned for an appropriate drape over the surface using digital elevation models and the flight characteristics of the aircraft. This plan is loaded into the GPS navigation system together with the planned survey tracks. The navigational system guides the aircraft crew to maintain the planned horizontal and vertical position of the aircraft along the flight line.

Another alternative flight mode is to conduct surveys at a constant elevation, generally at a constant barometric

elevation. This procedure is commonly used in surveys to map the depth to basement for petroleum exploration and in regions where the surface rocks are not magnetic and/or the surface relief is very rugged making it difficult to maintain constant terrain clearance. Considering average horizontal and vertical gradients of the geomagnetic field, in order to maintain an accuracy of 0.1 nT the flight path deviations in the vertical and horizontal directions need to be restricted to roughly 7 m and 30 m, respectively.

An important consideration in the flight-line specifications is the distribution of tie-lines. The magnetic data at the intersection of tie-lines and survey flight tracks are used to minimize variations in survey data due primarily to the temporal variations in the magnetic field over the course of the flight line measurements. The tie-line spacing must consider the temporal variation of magnetic field and the accuracy requirements of the objective of the survey. Accordingly, the spacing of tie-lines flown perpendicular to the flight survey pattern will vary with geomagnetic latitude as well as survey objectives. Generally, a tie-line/flight-line spacing ratio of roughly 3 is considered optimum, but it may reach values of 10 or more.

Instrumentation

Airborne measurements typically are made with alkali-vapor magnetometers with the sensor placed in a tail-stinger or in wingtip pods to minimize the need for compensation of the magnetic effects from the aircraft. The use of sensors in an aerodynamically stable housing that are trailed behind the aircraft on a cable at a distance beyond the meaningful magnetic effect of the aircraft has largely been eliminated except in helicopters. Inboard installations typically have a greater signal-to-noise ratio and are more convenient, safer, and less subject to oscillations during flights which degrade the accuracy of the observations. Thus, total field, vector, and gradient measurements are now made with inboard installations. Nonetheless, achieving the desired accuracy with inboard installations is a challenge because of magnetic effects of the aircraft (e.g. HARDWICK, 1984b).

There are several sources of magnetic noise from the aircraft, but the primary effect is from the magnetic components of the aircraft engine(s). As a result the sensor is placed as far from the engine as practicable, either as a stinger, which is most common, or as a wing pod. However, there are numerous other sources of aircraft magnetic noise such as induced magnetic effects in soft iron components in the aircraft, eddy currents arising from the currents in the airframe due to motion of this conductive medium through a magnetic field, and the magnetic effects of elec-

tric currents in electric and electronic components onboard the aircraft.

Adjustment for the magnetic effects of the aircraft is achieved either through passive and/or active compensation. Passive compensation, which involves placement by trial-and-error of permanent magnets or coils carrying a current and high permeability iron straps near the sensor that will cancel both the permanent and induced magnetic fields of the aircraft, has been the primary source of eliminating aircraft fields at the sensor. However, compensation can be more efficiently achieved using an analytical model that corrects the observations for the movement of the aircraft through the Earth's field. This is so-called active compensation. The active compensation model and its coefficients are derived from empirical observations of the magnetic effects of the aircraft (e.g. PICOENVIROTEC, 2009) when subject to maneuvers and driven by an orthogonal set of three flux-gate magnetometers that sense the variations in the pitch, yaw, and roll by the change in the amplitude of the field as measured by the flux-gate sensors. The active compensation methodology is now the principal method of compensating inboard magnetic sensors for the extraneous fields of the aircraft.

There are several other instruments that are necessary auxiliary equipment to the magnetic sensors. These include a data system for the preservation of the magnetic data and registering the coordinates and time of the data observations. Essentially all positioning of survey aircraft is achieved through differential GPS, which may be supplemented with Doppler and inertial navigational systems. Differential GPS achieves an accuracy of 1 to 5 m in position. In addition, some combination of laser, radio, radar, and barometric altimeters is used to establish absolute elevation and altitude of the aircraft above the ground surface. The accuracy of these instruments is quite different, with the high-precision laser altimeters achieving an accuracy of a few centimeters.

In addition to the onboard instrumentation, a magnetometer base station is established at a magnetically quiet site in the vicinity of the base of the survey operations to monitor the time variations in the field. If the survey is large or remote (≥ 50 km) from the survey base, an additional base magnetometer may be set up so that the survey operations are not much more than 50 km from a base magnetometer. Digital observations of this usually scalar instrument at a minute or second interval are recorded for later use in removing temporal variations in the magnetic field and to track the onset and dissipation of magnetic storm activity. Surveys are normally aborted if the monotonic variation in the field exceeds 2–5 nT over a 5 minute

period or pulsations of the field vary by several nanoteslas over periods of 5 to 10 minutes.

Pre-survey airborne tests

Three airborne tests of the magnetometer system are normally made prior to conducting a survey to insure the accurate measurement and location of anomalies. The first of these is the figure-of-merit (FOM) which determines the variation in the magnetic readings in an aircraft due to movements of the aircraft as it travels in different directions. As such the FOM evaluates the errors remaining in the observations after the sensor system is compensated for extraneous magnetic fields derived from the aircraft. In this test the aircraft repeatedly flies over a specific location where the magnetic anomalies are insignificant, going into $\pm 5^\circ$ pitches and yaws and $\pm 10^\circ$ rolls while flying north, south, east, and west during a period of stable temporal variations and over a time period of approximately 5 seconds. The sum of the difference in the amplitudes, without regard to sign, at the common point for the 12 different measurements is the FOM, which is commonly less than 1 nT.

Another test is the cloverleaf test which checks to be certain that there is no heading error in the observations. In this test, flights are made in a cloverleaf pattern in a region of low magnetic anomalies. The amplitude of the measurement of the center-point of the cloverleaf flown in the four cardinal directions should be the same if there is no heading error.

Finally, a lag test is performed to determine if there is a lag in the observation recovery system such that the data position is displaced from its true position. This is accomplished by making observations in opposite directions over an easily identified, isolated anomalous source such as a surface cultural source. The difference in the location of the anomaly on flights in the opposite direction is twice the lag of the system. It reflects lag in the electronics of the airborne system and different positioning of instrumentation in the aircraft. This lag, which is often of the order of several meters, should be taken into account in the positioning of the data observation.

11.5 Magnetic measurements from space

Satellite magnetic surveys provide unique constraints on the compositional, structural and thermal properties of the lithosphere to enhance the geological utility of near-surface surveys. Satellite data are also obtained essentially for the entire Earth and hardly any region outside about $\pm 87^\circ$ latitude is too remote for observation. Thus, patterns difficult to measure or perceive in near-surface surveys

are delineated by the broad data coverage. Additionally, satellite observations form a consistent data set free from non-uniformity caused by secular variations. They also are largely free from the effects of near-surface geologic sources that tend to mask or distort the signatures of deep, broad magnetic variations of the lithosphere. However, in combination with near-surface anomaly data, satellite magnetic observations provide important boundary conditions to enhance lithospheric modeling of anomaly variations from at or near the Earth's surface to satellite altitudes.

The realization of the importance of satellite magnetic observations for extending the geological utility of near-surface magnetic surveys and constraining crustal magnetization variations measured in hundreds to thousands of kilometers has led to increased availability of low Earth-orbiting (LEO) satellite magnetic surveys. The polar-orbiting Ørsted and CHAMP missions, which operated at altitudes of about 600–700 km and 300–450 km, respectively, provide two unique geomagnetic field boundary conditions to complement analyses of near-surface surveys. The data from these satellites are scheduled to be augmented around 2013 by a constellation of three near-polar-orbiting satellites from the Swarm mission. The Swarm measurements at altitudes of 450–550 km can be converted to gradient anomalies that will improve crustal anomaly estimates, especially in the polar regions where the distorting effects of the temporally varying external magnetic fields are strongest.

The instrumentation employed on most satellites for measuring the magnetic field is described by LANGEL and HINZE (1998). It consists of a boom-mounted tri-axial flux-gate magnetometer oriented by a star camera for measuring the relative vector components of the fields. In addition an alkali-vapor magnetometer is used to measure the absolute scalar magnetic field.

Magnetic measurements taken by satellites are dominated by the regional core field ($\sim 98\%$) and external field ($\sim 2\%$) components with minor contributions from the lithospheric field ($\leq 0.2\%$). These field contributions with source regions within and outside the Earth are illustrated in Figure 11.8. Satellite magnetic observations are commonly averaged spatially and rendered into global spherical harmonic models that are effective for core and external field studies. This approach is limited, however, for resolving anomaly detail in lithospheric studies, which tend to be more local in scope and conducted over finite spherical patches of the planetary surface. Furthermore, spherical harmonic model coefficient errors from gaps and uneven coverage in the global data set, and variable data measurement and diurnal field reduction

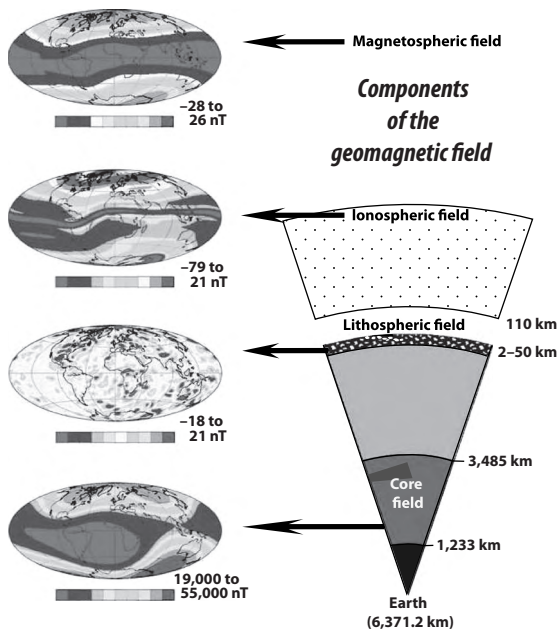

FIGURE 11.8 Satellite magnetic measurements are dominated by the effects of the main field (bottom) and the external fields (top), which include the ionospheric and magnetospheric fields. Lithospheric fields (second from bottom) make only minor contributions to satellite observations. A color version of the figure is available at www.cambridge.org/gravmag. Adapted from MANDEA and PURUCKER (2005).

errors can complicate local anomaly predictions. However, the regional scale of satellite observations greatly favors the use of spherical over linear Cartesian coordinates for efficient processing and analysis of the lithospheric anomalies.

For spherical patch applications, least-squares equivalent point source (EPS) modeling is effective for representing satellite magnetic observations in spherical coordinates. EPS modeling involves relating the satellite anomalies to the magnetic moments of a spherical distribution of equivalent point dipoles (Section 9.7.6) by least-squares matrix inversion (Appendix A.4.2). The spherical magnetic dipole is the simplest numerical source function to invoke, but spherical coordinate prisms and other simple equivalent sources with least-squares estimated magnetizations have also been used. The equivalent source models in turn can be processed for the magnetic potential, anomaly gradients, vector components, continuations and other signal properties because they are all linearly related as explained in Chapter 9.

Lithospheric studies require the extraction of the relatively minor lithospheric components in satellite magnetic observations that are strongly dominated by core and external field effects. However, local petrologic, structural,

thermal, and other lithospheric constraints can be effectively invoked for mapping lithospheric components which in turn can enhance local core and external field components, as described below.

11.5.1 Identifying lithospheric magnetic anomalies

The identification of the rather minuscule lithospheric components of the magnetic field at satellite elevations from the core-derived and time-varying ionospheric and magnetospheric components is a significant challenge. The amplitude of lithospheric magnetic anomalies is one thousandth or less of the core-derived field. Numerous methodologies have been described to achieve this goal (e.g. LANGEL and HINZE, 1998). The coherent or static properties of the lithospheric and core components, for example, can be exploited by the procedures in the flow chart of Figure 11.9 to extract lithospheric anomalies with considerable detail from satellite observations. This approach is similar to the efforts described in Section 5.5.2 that used spectral correlation theory (Appendix A.5.1) for extracting marine gravity anomalies from satellite altimetry. In satellite magnetic applications, spectral correlation theory can help to differentiate spatially and temporally static lithospheric and core components from dynamic external field effects. An additional separation of core and lithospheric components is also possible using their correlations with the magnetic effects of the crust's thickness variations modeled from seismic data, or isostatic analyses of the free-air and crustal terrain gravity effects (e.g. VON FRESE *et al.*, 1999a; LEFTWICH *et al.*, 2005) and other constraints.

Because the orbits are near-polar, they may be separated into the ascending and descending sets of sub-parallel tracks across the spherical patch of interest. Each data track includes overlapping long-wavelength core and lithospheric components that mostly occur in degrees 11–15 as shown in Figure 11.10. Accordingly, the separation of these fields at satellite altitudes is more problematic than at or near the crustal surface where the displacement distances of the sources are significantly smaller (e.g. LANGEL and ESTES, 1982; MEYER *et al.*, 1985; VON FRESE *et al.*, 1999b).

To facilitate the separation of the core and lithospheric components, each track is reduced for two core field models to isolate, for example, the components in the degree 11–15 band. Track residuals obtained by removing the presumed core field through the lower degree (e.g. degree 11) contain crustal magnetic components of degree 12 and greater and the core field components essentially up to degree 15 (Figure 11.10).

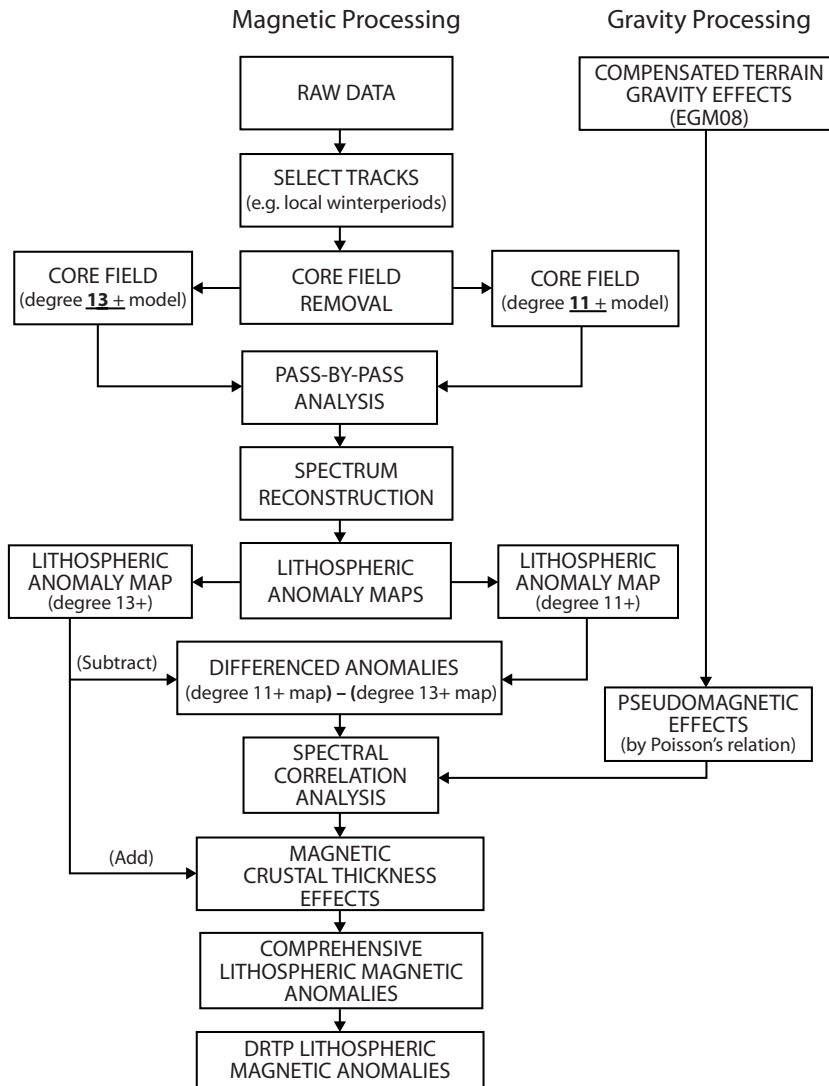

FIGURE 11.9 Data reduction scheme for extracting lithospheric anomalies from satellite magnetometer observations; differentially reduced-to-the-pole (DRTP); see text. Adapted from VON FRESE and KIM (2003).

On the other hand, removing presumed core field estimates through degree 15 yields residuals that contain essentially crustal components with minimal core field effects.

Each set of residuals is processed for separate estimates of the static core and lithospheric field components. This processing involves correlation-filtering the residuals between neighboring tracks for correlative data features that can reflect the static core and lithospheric effects. Common core field and lithospheric anomaly components will be registered on neighboring passes separated by small distances relative to altitude, whereas data components that do not correlate between these passes must involve

non-lithospheric and -core effects. The resulting enhancement of the correlation coefficient between the filtered neighboring residual data tracks improves the lithospheric anomaly signal to non-lithospheric noise according to Equation A.72.

The correlation-filtered residual ascending and descending data tracks are then processed into maps at common altitude and spherical coordinates by least-squares collocation (GOYAL *et al.*, 1990), or EPS inversion, or some other procedure that accounts for the large altitude variations in the orbital data. The co-registered ascending and descending maps for each residual data set are also correlation filtered against each other for common

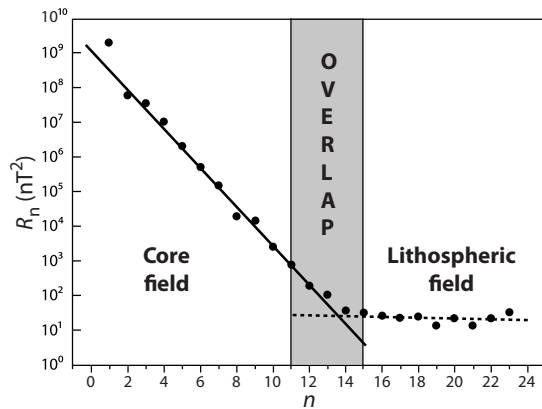

FIGURE 11.10 The Lowes-Mauersberger (R_n) spectra of the geomagnetic field at the Earth's surface, where R_n is the mean square amplitude of the magnetic field over a sphere produced by harmonics of degree n . Magsat magnetic observations established the presence of the prominent break in the slopes where the core and crustal field components overlap in spherical harmonic degrees $n = 11-15$ centered roughly on degree 13. Adapted from LANGEL and ESTES (1982).

features to further reduce non-lithospheric and -core field noise.

The principal difference in the correlation filtered output maps is the corrugation or track-line noise that results from the along-track processing of the orbital data (KIM *et al.*, 1998b). This washboard effect gives each map a corrugated texture that trends along the respective strikes of the ascending and descending orbital data tracks. In the wavenumber domain, track-line noise effects are typically concentrated in only two spectral quadrants of each map, and the corrupted quadrants are different between the ascending and descending maps because of the different strike orientations of the respective data orbits. Thus, the mutually exclusive pairs of cleaner quadrants from the ascending and descending maps can be combined into a reconstructed spectrum that, when inversely transformed, yields a magnetic map with minimal track-line noise of the static components presumed for the core and lithosphere.

To separate the lithospheric and core components, the differences obtained by subtracting the static lower-degree (e.g. degree 11) core field residuals from the higher-degree (e.g. degree 15) core field residuals are considered as shown in the bottom half of the flow chart in Figure 11.9. In terms of the overlap generalized in Figure 11.10, for example, the differences include the mixed core and crustal components in the core field model through degree 15 plus the static degree 11-15 components from the track data that presumably reflect additional core and lithospheric contributions. As indicated in the flow chart (Figure 11.9),

the crustal components in the residual degree 11-15 components may be extracted by correlation filtering using independent crustal field models derived from collateral geophysical information. The extracted components may be added to the static degree 15 and higher lithospheric anomaly estimates to obtain a comprehensive lithospheric anomaly map for the spherical patch in degrees 11 and higher. The remaining non-lithospheric differences provide presumably enhanced degree 11-15 core field model estimates consistent with local lithospheric constraints in the satellite magnetic observations (e.g., VON FRESE *et al.*, 1999b; KIM *et al.*, 2002; VON FRESE and KIM, 2003).

At the regional scales and altitudes of satellite magnetic surveys, displacements in the spatial relationships between lithospheric sources and total field anomalies can be severe. Thus, as a further processing step (Figure 11.9) in preparing satellite observations for lithospheric analysis, satellite total field anomalies can be differentially reduced-to-the-pole (DRTP) to minimize these spatial distortions. The DRTP procedure adjusts for the intensity, inclination, and declination variations of the core field by evaluating the EPS model of the comprehensive total field anomalies at vertical inclination and a constant magnetization intensity. The induced components of DRTP anomalies are centered on their lithospheric sources as if the sources were at the geomagnetic poles. Thus, DRTP anomalies facilitate linking magnetic observations with the lithospheric geology, as well as gravity, heat flow, and other source-centered geophysical variations.

11.5.2 Satellite magnetic mapping progress

The satellite era began with the successful launch of Sputnik 3 in 1958 which carried flux-gate magnetometers that mapped portions of the geomagnetic field to an accuracy of about 100 nT over altitudes of roughly 225-1,900 km. Since Sputnik, some 23 additional low Earth-orbiting (LEO) satellites have been operated mostly to map and monitor the behavior of the Earth's core field (e.g. LANGEL and HINZE, 1998).

A series of satellites operated over 1967-1971, called Polar Orbiting Geophysical Observatories (POGO), obtained total field data with measurement accuracies of about 6 nT that identified the intense Bangui anomaly from crustal rocks of west central Africa (REGAN *et al.*, 1975). This finding prompted efforts to develop a satellite mission dedicated to mapping lithospheric magnetic fields. Accordingly, the 7 month Magsat mission was launched in November 1979 to extend POGO's lithospheric

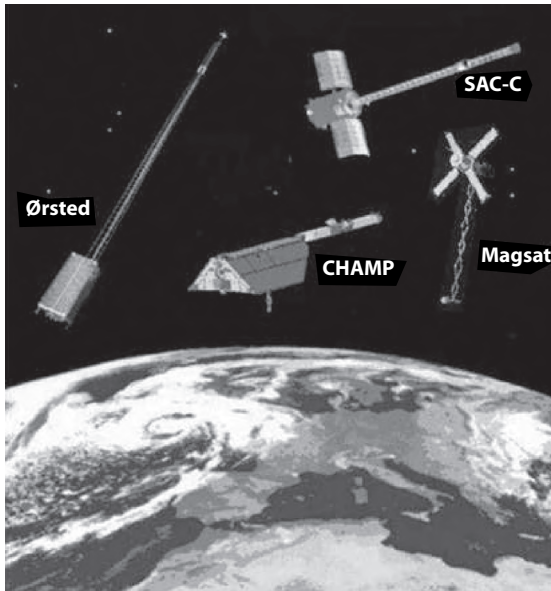

FIGURE 11.11 Low Earth-orbiting (LEO) geomagnetic field mapping satellites. Booms extend the magnetometers away from the electromagnetic environments of the satellites. A color version of the figure is available at www.cambridge.org/gravmag.

findings by mapping not only the field's magnitude but also its direction, and thus the magnetic vector components. The measurement accuracies in the total field and vector components were 3 and 6 nT, respectively. In addition, Magsat operated at more circular and lower altitude (~350–450 km) orbits than the POGO satellites to better resolve magnetic anomalies of the lithosphere. However, the utility of Magsat data for lithospheric studies of the southern hemisphere was limited because the mission flew during austral summer and fall when the corrupting effects of the south polar external fields on the measurements were maximum.

The Magsat data have been essentially replaced for lithospheric studies by the more accurately measured and temporally extensive data sets mapped by the Ørsted (1999–2009) and CHAMP (2002–2010) missions at respective altitude ranges of roughly 600–750 km and 300–450 km (Figure 11.11). The latter two missions carried resonance and flux-gate magnetometers that provided both total and vector component data to measurement accuracies of about 0.5 nT. Deployed on optical benches or booms, the magnetometers were monitored for their in-flight temporal and spatial orientations using onboard GPS receivers and star cameras. The LEO observations from the Magsat, CHAMP, and Ørsted satellites have yielded significant constraints on the regional petro-

logic variations of the crust and upper mantle (i.e. the lithosphere), and crustal thickness and thermal perturbations. These observations know no political boundaries, have uniform accuracy and spatial distribution, and were acquired in time spans short enough that the time variation of the Earth's main field is not a limiting factor to interpretation.

The above missions were all launched into near-polar orbit at inclinations no greater than about 87.5° , and so the orbits track tangentially to the outer margins of polar holes or gaps in coverage with diameters no smaller than about 5° across the poles. Thus, the track coverage density increases from the equator, where the tracks are essentially parallel and trend N–S, to the polar gaps where the number of track cross-overs is maximum. However, in terms of the internal field components from the core and lithosphere, the minimum resolvable full wavelength is roughly at the orbital altitude scale. Thus, the CHAMP mission, for example, resolves lithospheric anomalies at wavelengths no smaller than about 300–400 km.

Efforts to remove diurnal effects are basically relegated to selecting orbital data tracks measured over magnetically “quiet” periods as indicated by the geomagnetic observatory-measured activity indices. This approach, however, is suspect because the ground-based indices often show little or no correlation to satellite-altitude disturbances of the data variances in the orbital measurements. Each orbit takes about 96 minutes to complete, so that the spatially and temporally variable diurnal fields tend to be dispersed over the orbital measurements as mostly random effects relative to the coherent effects of the core and crust. Thus, correlation filtering of neighboring orbital data tracks and anomaly maps at different local magnetic times can help to suppress the predominantly uncorrelated effects of the dynamic external fields in the satellite measurements as described previously in Section 11.5.1.

Given the vast amounts of magnetic observations collected by the multi-year Ørsted and CHAMP missions, anomaly maps are commonly made by isolating the orbital data obtained during magnetically quiet periods, and adjusting the extracted data using first-order models of the ring current, magnetopause current, tail current, field-aligned currents, and other external field effects (Figure 8.3) that can be calibrated by the mission data (e.g. LANGEL and HINZE, 1998). The reduced anomaly data are next gridded in spherical coordinates using the 3D binning process described previously in Section 5.5.3 for gridding satellite gravity observations. The magnetic anomaly grid is then transformed for analysis and interpretation into a set of spherical harmonic coefficients.

The spherical harmonic series for the magnetic potential function, for example, may be written as

$$\begin{aligned}
 V(r, \theta, \phi) &= a_e \sum_{n=1}^{\infty} \sum_{m=0}^n \left(\frac{a_e}{r}\right)^{n+1} P_{n,m}[\cos(\theta)] [g_{n,m} \cos(m\phi) \\
 &\quad + h_{n,m} \sin(m\phi)] + a_e \sum_{n=1}^{\infty} \sum_{m=0}^n \left(\frac{r}{a_e}\right)^n P_{n,m}[\cos(\theta)] \\
 &\quad \times [q_{n,m} \cos(m\phi) + s_{n,m} \sin(m\phi)], \quad (11.1)
 \end{aligned}$$

where the variables are the same as for the spherical harmonic gravity potential in Equation 5.15 except that the $P_{n,m}[\cos(\theta)]$ are the Schmidt quasi-normalized forms of associated Legendre functions of degree n and order m , and the $g_{n,m}$, $h_{n,m}$, $q_{n,m}$ and $s_{n,m}$ are the Gauss coefficients of \mathbf{B} relative to $P_{n,m}[\cos(\theta)]$ (e.g. LANGEL and HINZE, 1998). The $g_{n,m}$ and $h_{n,m}$ coefficients describe fields originating within the Earth, whereas the $q_{n,m}$ and $s_{n,m}$ coefficients describe fields originating outside the Earth. The internal \mathbf{B} contains contributions from the Earth's core, lithosphere, and induced currents of the subsurface.

As discussed previously for spherical harmonic representations of satellite gravity data in Section 5.5.3, the effective degree and order of the spherical harmonic expansion is fundamentally constrained by the altitude of the observations, assuming the observations are spaced laterally at intervals smaller than the altitude. Thus, the internal field effects observed over an altitude of 400 km, for example, may be reliably modeled in principle to spherical harmonic degree and order of roughly 100, although in practice the higher-degree terms tend to be increasingly corrupted by measurement errors, external field components, and other noise in the observations. Based on the coefficient powers, the components through about degree and order 13 are commonly ascribed to the core field with the higher-degree and -order terms assigned to the lithospheric field. However, as described previously, this simple interpretation of the lithospheric anomalies is greatly complicated by their spectral overlap with the core field components and contamination by external field effects, because both non-lithospheric sources produce magnetic effects that are typically orders of magnitude larger than the lithospheric anomalies.

Figure 11.12 gives a global total field Earth Magnetic Anomaly Grid (EMAG2) that incorporates satellite, airborne, and ship magnetic survey data, as well as extrapolated marine anomalies based on oceanic crustal age modeling (MAUS *et al.*, 2009). The grid is the basis for the 720 degree and order spherical harmonic NGDC720 geomagnetic model ([http://www.ngdc.](http://www.ngdc.noaa.gov/geomag/EMM/emm.shtml)

[noaa.gov/geomag/EMM/emm.shtml](http://www.ngdc.noaa.gov/geomag/EMM/emm.shtml)) that provides field components at a resolution of about 15 arcmin. However, care must be taken to check the reliability of model predictions which can be highly problematic at points located a hundred or more kilometers from measured anomalies. Over the large unsurveyed blank areas of the Antarctic grid in Figure 11.12, for example, the model predictions are most reliable at satellite altitude, but of little or no consequence at the 4 km altitude of the grid because of magnetic anomaly measurement and reduction errors, as well as the fundamental non-uniqueness of the underlying magnetic model and its predictions in unsurveyed areas (e.g. VON FRESE *et al.*, 2005).

Magnetometers are routinely deployed in the exploration of the planetary bodies of the solar system because they acquire with relative ease measurements of considerable geological and planetary significance. As a result, a variety of magnetic anomaly measurements have been obtained for the Moon, Mars, and Venus that offer important constraints for geological investigations of these bodies and their satellite gravity, topography, and other remote sensing observations (Section 7.4).

Magnetometers onboard the lunar Apollo subsatellites, for example, showed that the Moon's external magnetic field is very weak compared with the Earth's field. The Moon lacks a core field, although one may have operated in its early history to produce the remanent magnetization observed in the returned lunar rocks, and the crustal anomalies mapped by magnetometers on the lunar surface and by the electron reflectometers and magnetometers onboard the Apollo subsatellites (e.g. FULLER and CISOWSKI, 1987). The Apollo data mapped numerous crustal magnetic anomalies with wavelengths of several to hundreds of kilometers and amplitudes of less than a nanotesla to greater than 100 nT. These results were confirmed and further detailed and extended in coverage by the magnetometer data from the Lunar Prospector (e.g. HOOD *et al.*, 2001) and SELENE (e.g. TSUNAKAWA *et al.*, 2010) missions. For the most part, lunar crustal anomalies appear to reflect mostly the crustal demagnetizing and magnetizing effects of large meteorite impacts at the impact basins and their antipodes, respectively.

The fact that Mars also lacks a core field was first inferred as a result of the Mariner-4 spacecraft flyby in 1965. However, a core field may have operated in its early history to produce the remanently magnetized meteorites found on Earth that are presumed to have come from Mars, and the crustal magnetic anomalies mapped by the magnetometer and electron reflectometer onboard the Mars Global Surveyor (MGS). Remarkably strong crustal anomalies occur over the ancient cratered southern

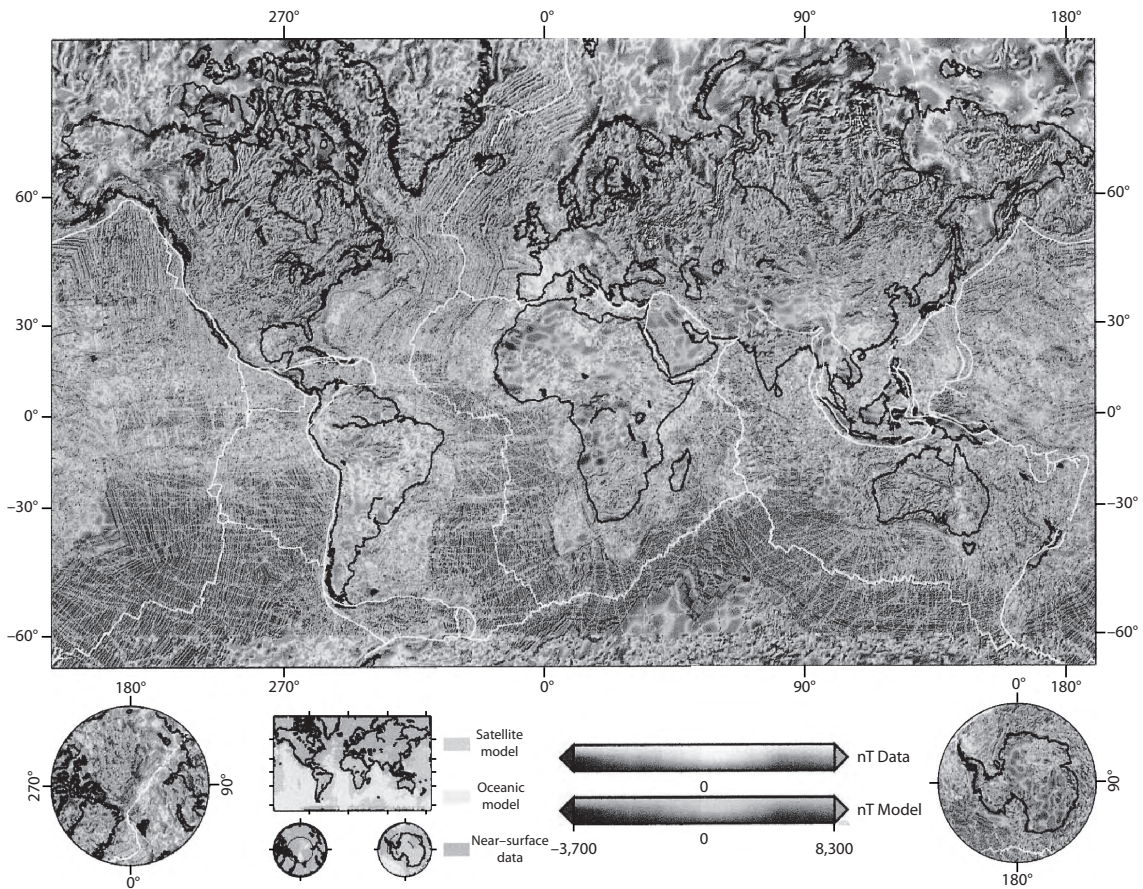

FIGURE 11.12 Mercator and polar stereographic projections ($>40^\circ$ latitude) of the EMAG2 global grid. The grid has a resolution of 2 arcmin and is referenced to an elevation of 4 km above the geoid. A color version of this figure is available at www.cambridge.org/grammag. Adapted from MAUS *et al.* (2009).

hemisphere crust with amplitudes up to 1,500 nT at elevations of about 100–200 km, whereas much weaker anomalies with amplitudes <50 nT characterize younger impact-modified crust such as covers the northern hemisphere (e.g. ACUÑA, 2001). Crustal modeling of the MGS magnetic anomalies is subject to ongoing investigations, but would require intensely magnetized rocks with average natural remanence of about 20 A/m over large 30 km thick crustal slabs with minimum horizontal dimensions no smaller than about 100 km (e.g. ACUÑA *et al.*, 1999).

The most definitive measurements to date of the Venesian magnetic field were obtained by the Pioneer Venus Orbiter mission during its first years of operation (1979–1981). The spacecraft made repeated passes at altitudes of about 150 km which showed that Venus also lacks a significant core field. In addition, crustal surface temperatures of around 450°C have been measured that suggest temperatures within the crust are probably above the Curie point.

Given the apparent absence of a core field and inferred high crustal temperatures, it seems unlikely that the crust can be a source of magnetic fields. Thus, the relatively weak variations (10–100 nT) in the Venesian magnetic observations have been ascribed mostly to interactions of the solar wind with the ionosphere of Venus (e.g. LUHMANN, 1986).

11.6 Key concepts

- Magnetic instrumentation and procedures have greatly improved since the late 1940s when most exploration observations were made with tripod-mounted mechanical instruments which measured a vector component of the magnetic field. These improvements have made it possible to routinely make measurements to an accuracy of 0.1 nT from airborne, marine, and satellite platforms. In addition, measurements are not only made of the total field, but now regularly include vector, gradient,

and tensor components. As a result magnetic surveying, which is inexpensive and rapid compared with other geophysical measurements, is extensively used over a range of scales of applications. These investigations extend from studies of near-surface anthropogenic features to regional geological and tectonic features of the continents, oceans, and extraterrestrial bodies.

- The majority of magnetic measurements are made of the total field with nuclear magnetometers which do not have to be accurately oriented, and thus can be used on moving platforms. The earliest nuclear magnetometer, the proton-precession magnetometer, measures the frequency of the precession of the protons in a fluid sensor around the geomagnetic field after being displaced by an applied magnetic field. The frequency of this precession is related to the total (scalar) magnetic field through a well-known constant. However, limitations of the proton-precession magnetometer have caused it to be largely replaced by the more sensitive alkali-vapor magnetometer. The cesium-vapor version of this magnetometer, which uses the principle of optical pumping to measure the ambient magnetic field, is widely used in exploration magnetics. In turn this instrument is being replaced in some applications by the Overhauser magnetometer because of its improved signal-to-noise ratio and reduced measurement uncertainties and power requirements. Also, this spin-precession magnetometer is essentially continuously recording and is not subject to heading or orientation errors.
- The first magnetic instrument usable in aircraft for geological exploration was the flux-gate magnetometer. Although it is a vector magnetometer, it was used in a configuration on moving platforms that constantly oriented it in the direction of the Earth's field. Thus, it measured the total field but in a relative rather than an absolute sense as nuclear magnetometers do. It has been superseded in most exploration applications by nuclear magnetometers except for measuring vector components of the field and their gradients. A significantly more sensitive vector magnetometer is the SQUID which operates in a cryogenic environment. It is receiving increasing attention as an exploration instrument because of its high sensitivity which makes it particularly useful in tensor measurements.
- The vast majority of exploration magnetic measurements are the total field component. However, vector measurements are still of interest because they have advantages over total field values in isolating Earth-derived fields in special cases and they can be used to improve the quality and stability of magnetic interpretation. Also, gradients of both the total field and its vector components, measured as the difference between two magnetometer sensors, have important uses in exploration magnetics. They have the advantage of being free of extraneous effects of temporal variations and they increase the resolution of the measurements, and thus their ability to isolate anomaly sources.
- Ground magnetic surveys are used to map near-surface natural or cultural features with the highest resolution and an appropriately high data density. Station separation should not exceed the anticipated depth to the anomaly sources and closer intervals are required for satisfactory quantitative analysis. The proximity of extraneous ferrous metals and electric currents which generate magnetic fields in ground surveys necessitates care in the siting of observations to minimize effects from these sources. Near-surface surveys of extensive regions are expedited with measurements using various forms of transport including helicopters, unmanned remotely controlled aircraft, and surface vehicles. The positioning of observations is typically established with GPS mapping systems. Temporal variations in the magnetic field over the period of surveying can be monitored with measurements from a nearby base magnetometer or reoccupation of a base station within the survey area. The interval between reoccupations is a function of the variability of the field, both its gradient and amplitude, and the accuracy requirements of the survey. Reoccupation intervals are commonly no more than an hour.
- Marine magnetic surveys are usually conducted as a supplement to other geophysical/oceanographic surveys with a sensor towed beneath the sea surface at a distance which excludes the effects of the towing vessel on the sensor. Difficulties arise with temporal magnetic variations because base magnetometers and tie lines are often limited or of restricted quality. As a result of this problem, gradiometer configurations are sometimes employed at sea. In areas of deep water, it may be necessary to track the sensor close to the water bottom to increase resolution.
- Airborne magnetic survey is the principal source of magnetic anomaly data because it is economical, rapid, and efficient in studying extensive regions, and minimizes the effects of temporal variations and cultural features. Surveys are conducted with a wide variety of operational and survey procedures taking into account the objectives of the survey and the terrain. Data are acquired at high density along parallel flight lines generally separated by a distance roughly equivalent to the depth to magnetic sources, although this will vary with the objective of the survey. Flights for geological mapping of sources close to the surface are normally flown at roughly 150 m

above mean terrain to achieve high resolution without compromising the safety of the aircraft. Other flight modes include surveys draped over mean terrain and constant flight altitudes. The latter are used especially in petroleum surveys where the objective of the magnetic survey is mapping of buried basement. Temporal variations during flight operations are determined in airborne surveys with base magnetometers and tie-lines flown at distances of a few to 10 times the survey flight lines. Most surveys are conducted with alkali-vapor magnetometers with inboard installations that are compensated for a variety of extraneous magnetic fields from the aircraft. An accuracy of 0.1 nT is attained in many surveys making them useful in high-resolution studies. Total field measurement may be supplemented with gradient, vector, and tensor observations in airborne surveys to improve the quality of the interpretation.

- Satellite magnetic missions have been flown for several decades to study the nature and configuration of the main geomagnetic field, but increasingly these measurements have provided long-wavelength magnetic anomaly (> 500 km) information useful in the study of continental-scale geologic sources of the lithosphere. Recent satellite missions at altitudes of roughly 500 km have achieved an accuracy of 0.5 nT in the measurement of both scalar and vector anomalies. Satellite measurements are especially useful because they provide a synoptic view of the magnetic field, and the repetitive measurements of overlapping orbits can be used to minimize extraneous magnetic fields of the ionosphere from lithospheric anomalies. These measurements are being used to provide important information about the nature and history of other terrestrial bodies.

Supplementary material and Study Questions are available on the website www.cambridge.org/gravmag.