

Analise Instrumental I

Sistemas de Análise em Fluxo - FIA

Gentilmente cedido pela Prof. Patrícia Benedini Martelli –
UFSJ

*“ The importance of analytical chemistry is not arguable.
Three things in life are certain: death, taxes,
and the need for analytical chemistry”*

Peter Kissinger.
Analytical Chemistry, 73(3):55A, 2001.

Análise quantitativa

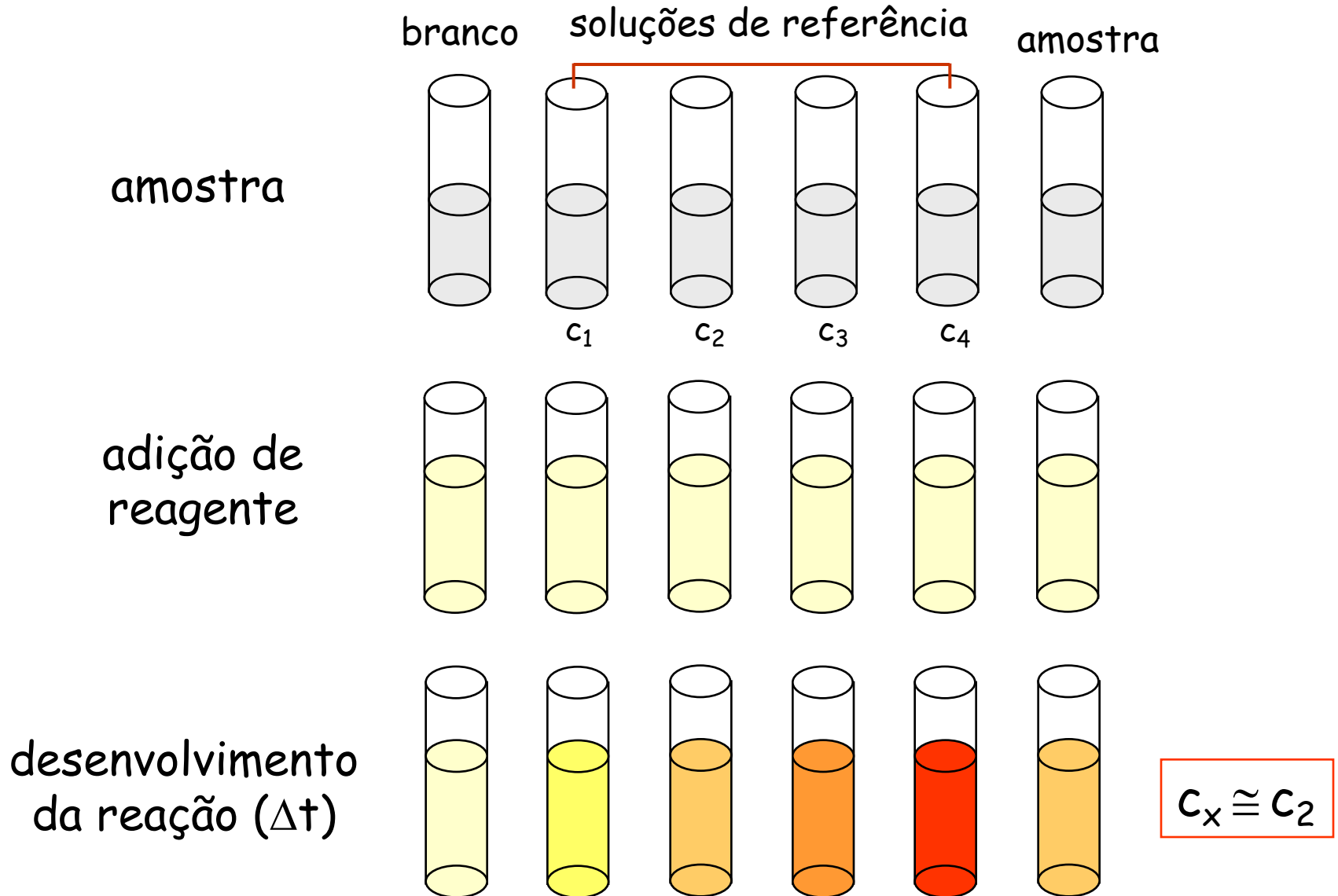

Análise quantitativa

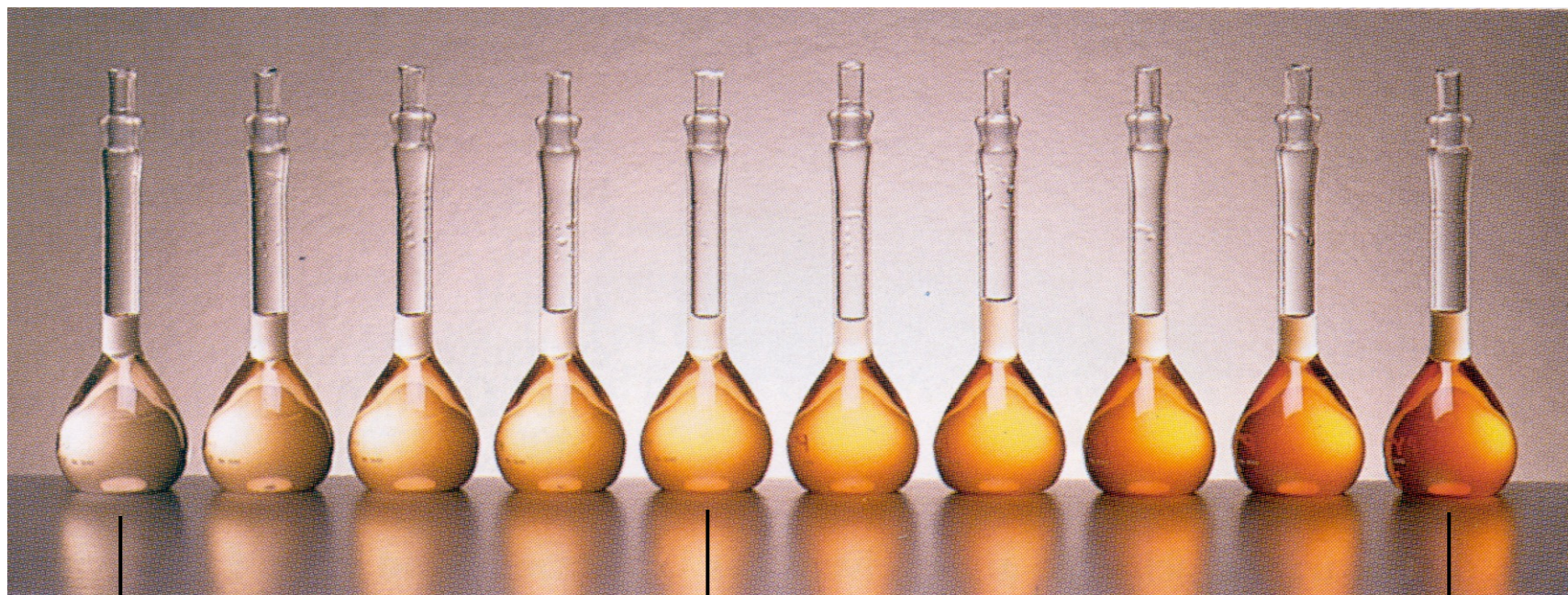
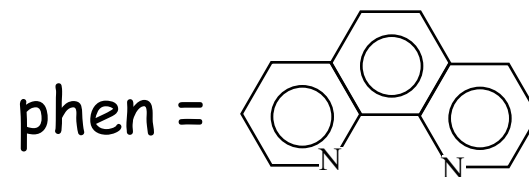
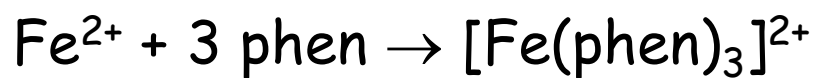
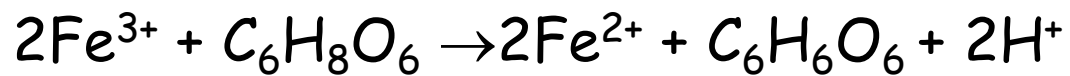

branco

5 mg L⁻¹

10 mg L⁻¹

Análise em fluxo contínuo (segmentado)

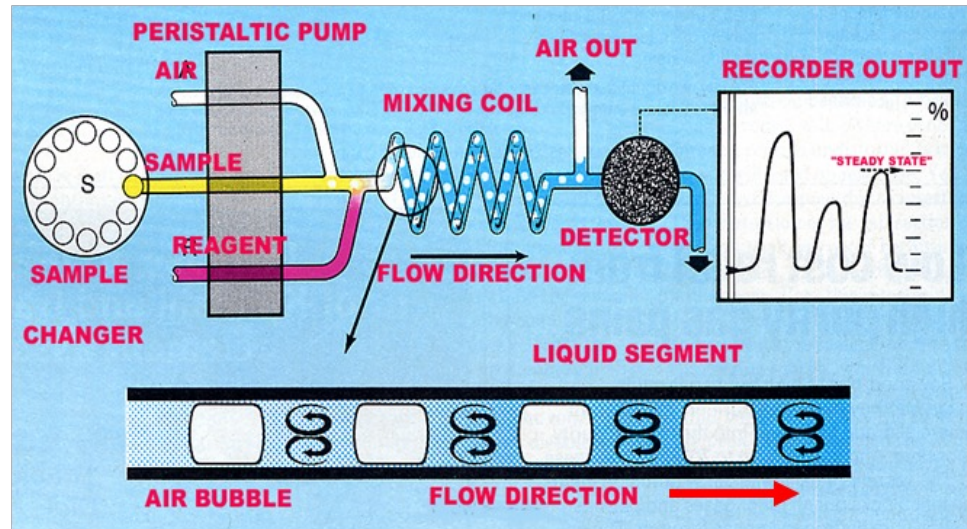

⇒ comercialização: Autoanalyzer® (Technicon)

1957 → Analisador de fluxo contínuo segmentado por ar

- Skeggs, L.T.; Automatic method for colorimetric analysis.
Amer.J.Clin. Pathol., 38 (1957) 311.

"I was worried about the quality of the results. I put unknowns into every batch of analyses and found frequent, very bad errors. There were just too many manual operations. I dreamed of a machine that would do analyses without error."

"One day, It suddenly occurred to me that analyses could be done in a continuously flowing stream rather than in batchwise or discretely."

-Skeggs, L.T.; Persistence...and prayer: From the artificial kidney to the autoanalyzer. *Clin. Chem.*, 46 (2000) 1425.

Technicon

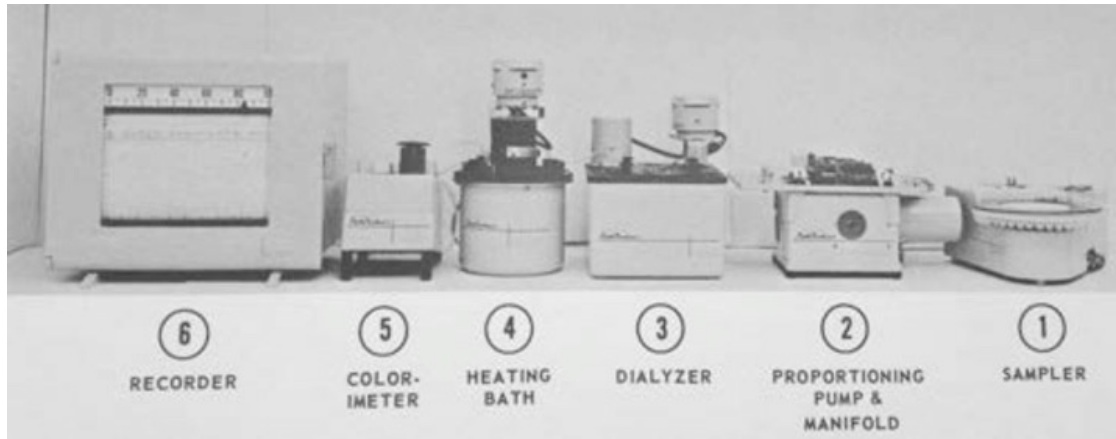

AutoAnalyzer I

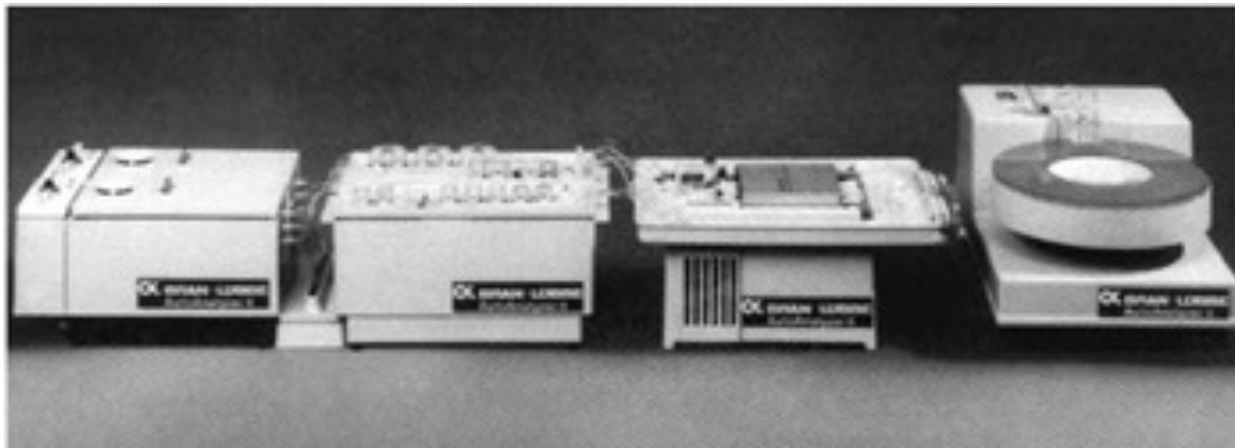

II



III

Histórico

1975 → Análise por Injeção em Fluxo
FIA - Flow Injection Analysis

- Ruzicka, J.; Hansen, E.H.; Flow injection analyses. Part I. A new concept of fast continuous flow analysis. *Anal. Chim. Acta*, 78 (1975) 145.



J. Ruzicka



E.H. Hansen

Apparatus in which FIA begun, the Technical University of Denmark, spring 1974. 1- peristaltic pump; 2-Air Gap electrode 3-Potentiometer (Radiometer, Copenhagen). 4-Recorder (Radiometer Copenhagen). Reagent bottles with ammonium chloride, water and sodium hydroxide. Flowrate 14mL/min, injected volume 1mL.

Eureka?

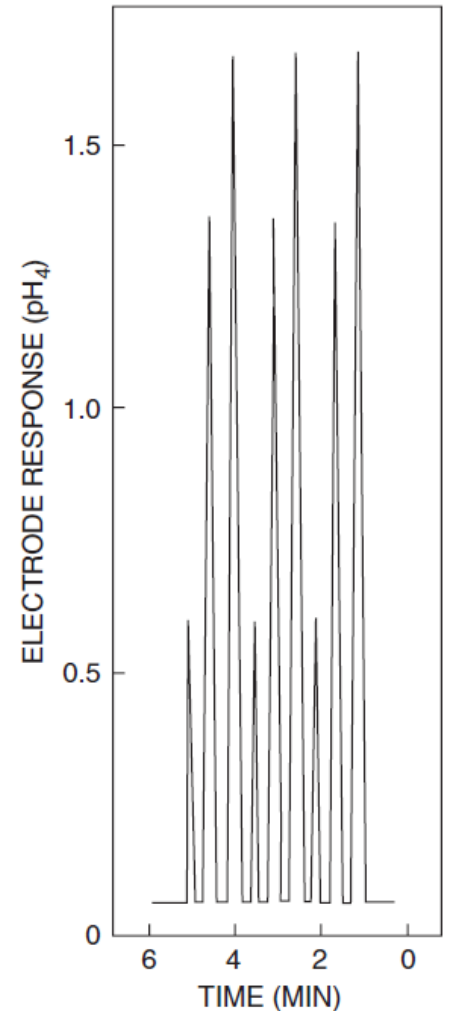
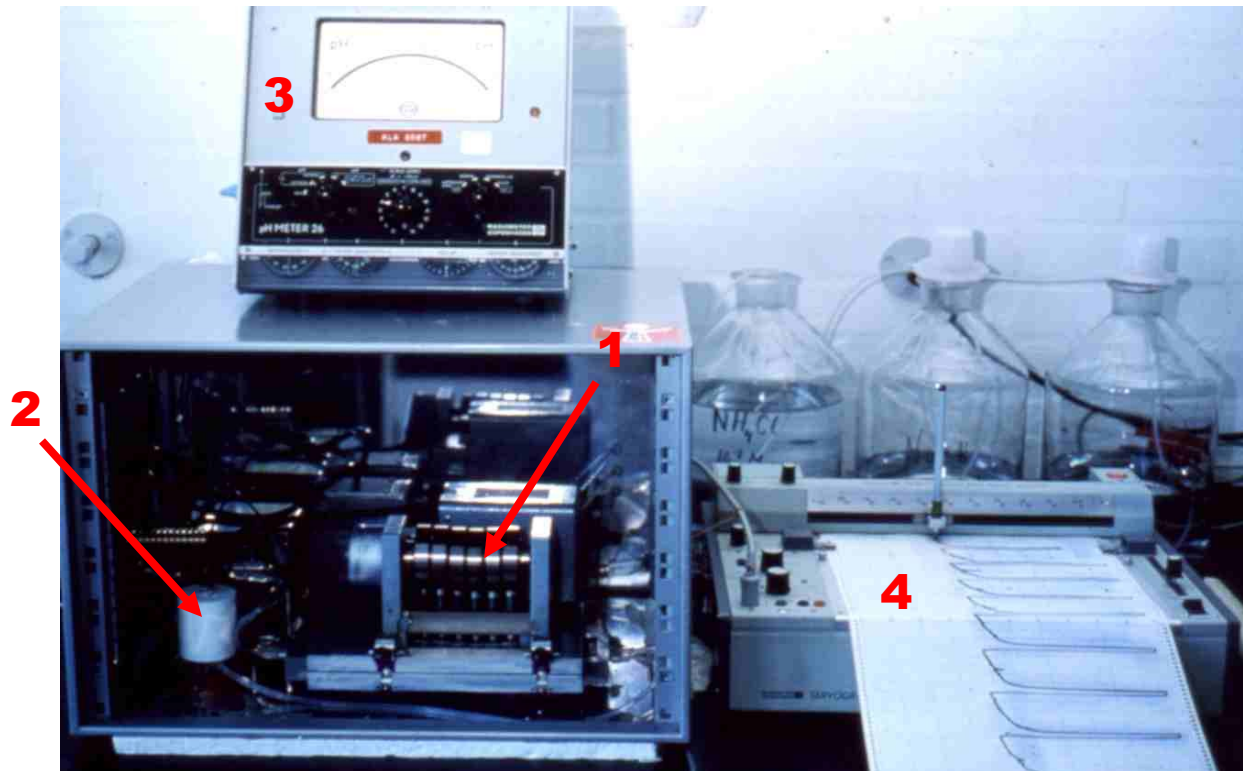

Eureka!



Single reagent

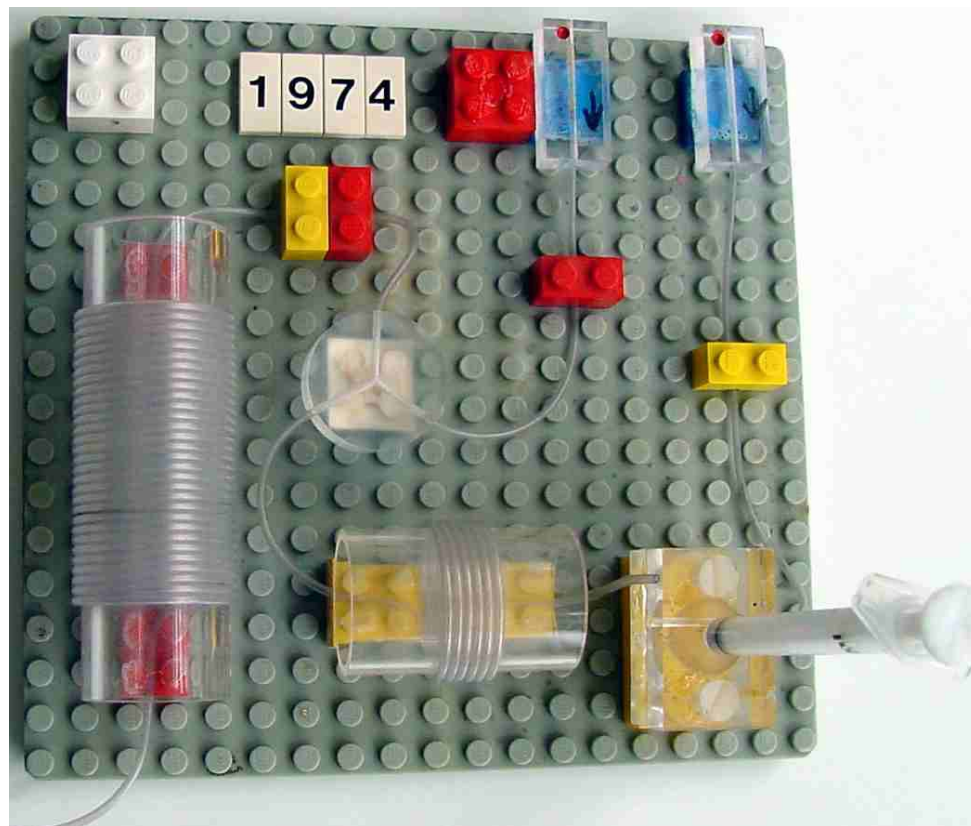

Two reagents, confluence point



Ruzicka, J no CENA

FIA

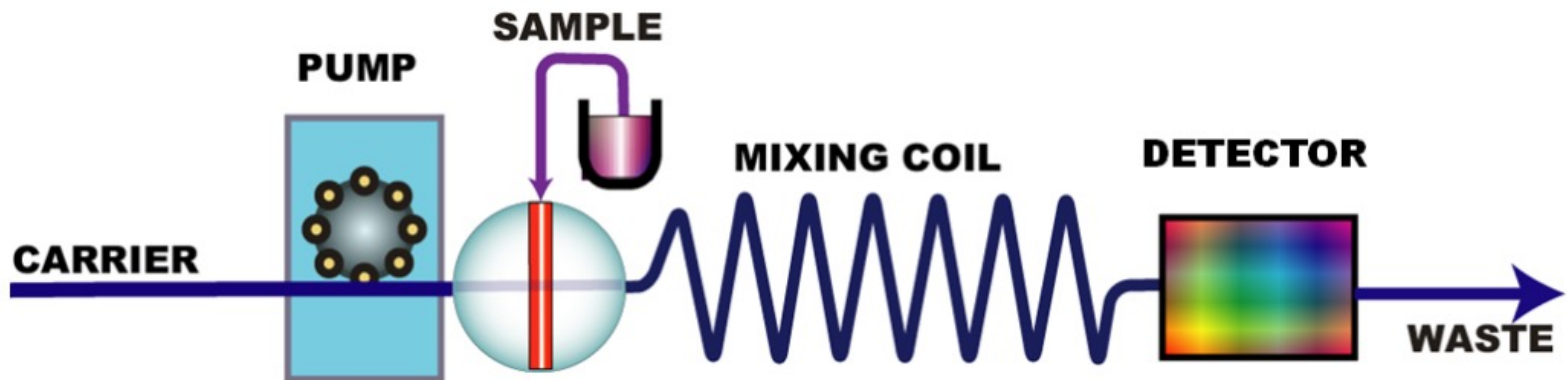

1975 - CENA (USP)



F.J. Krug Reis, Zagatto, Bergamin H. Bergamin Filho



Elias. A. G. Zagatto

Boaventura F. Reis

Francisco J. Krug

Análise por Injeção em Fluxo - Princípio

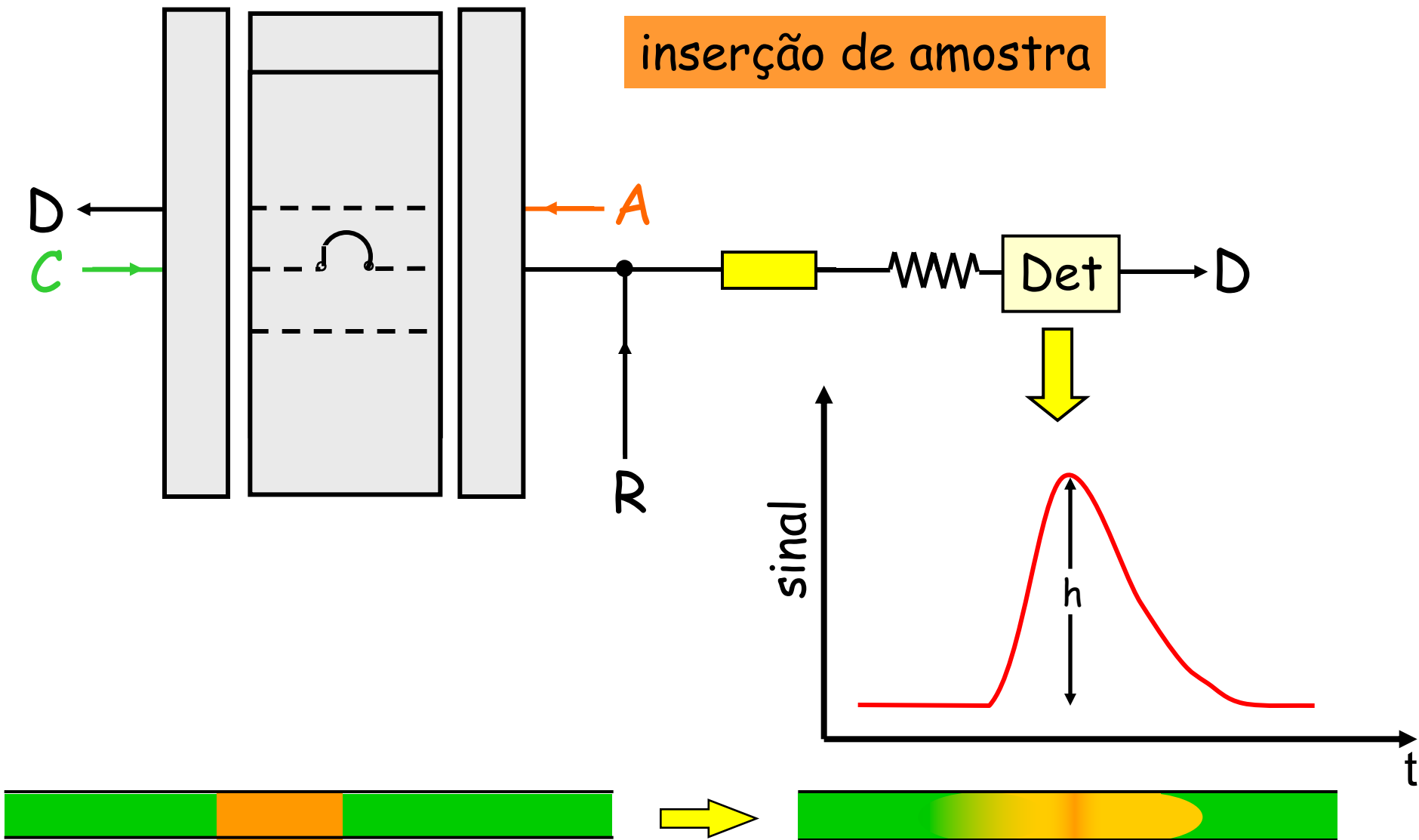

Injetor proporcional - Instrumentação

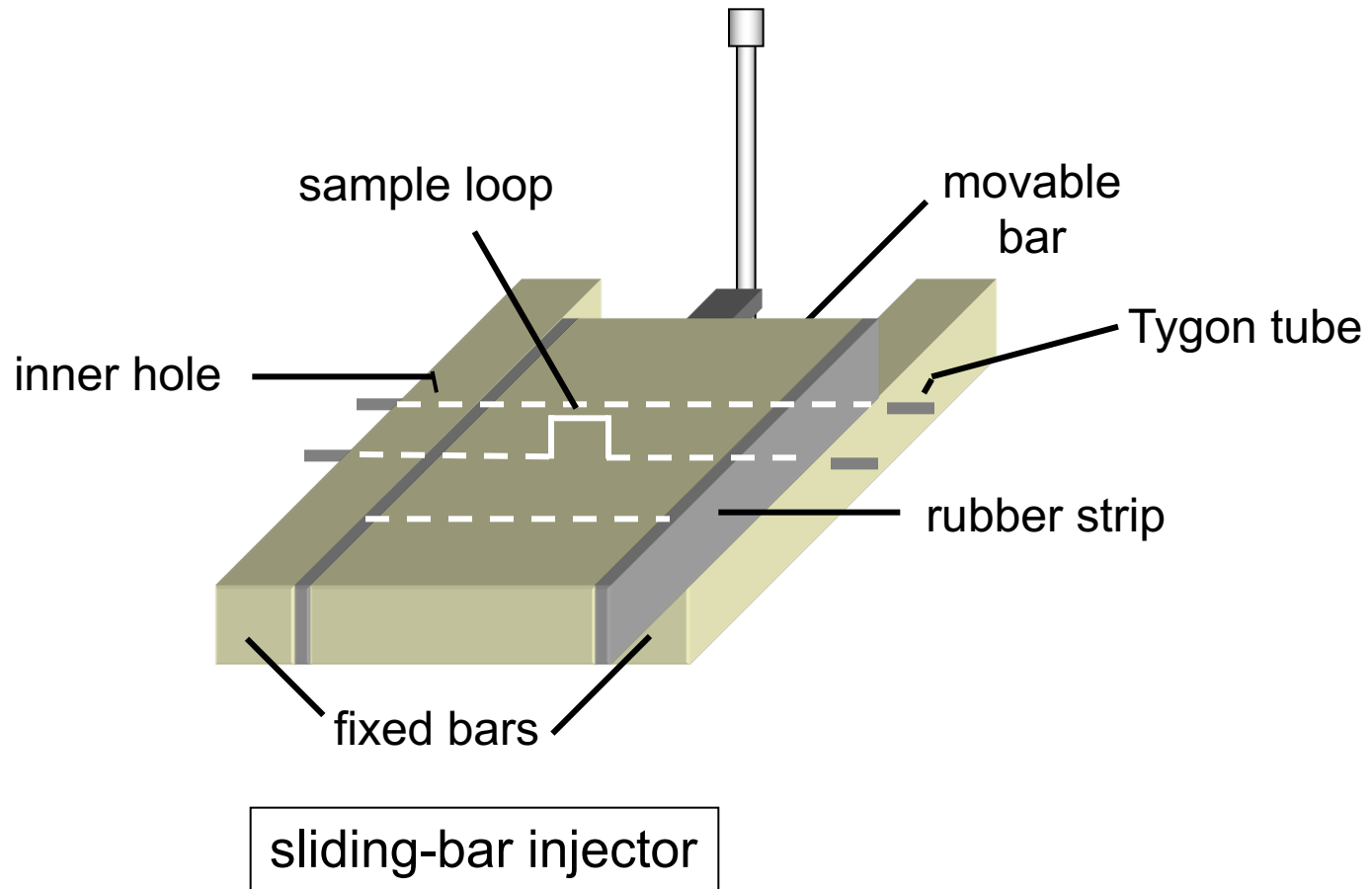



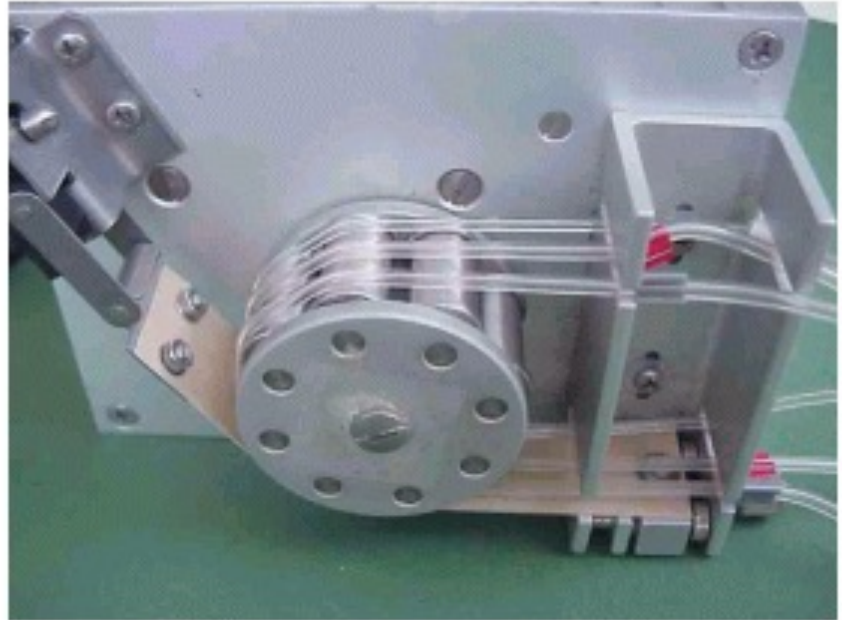

Análise por Injeção em Fluxo - Componentes

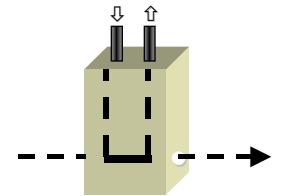
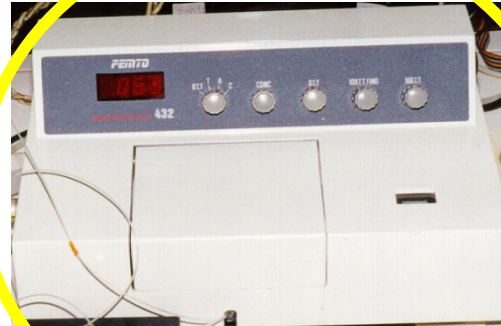
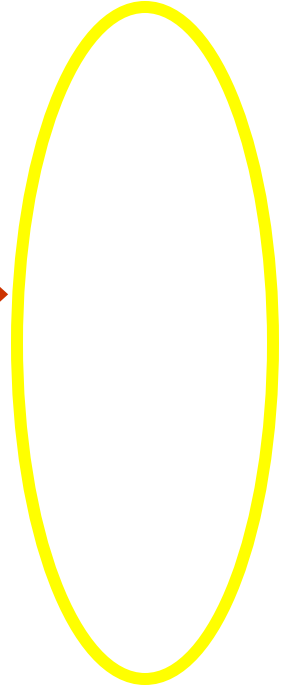
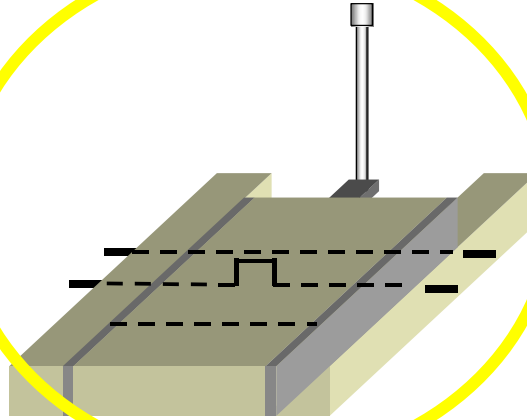

Outros detectores...

Análise por Injeção em Fluxo (FIA) - Princípios

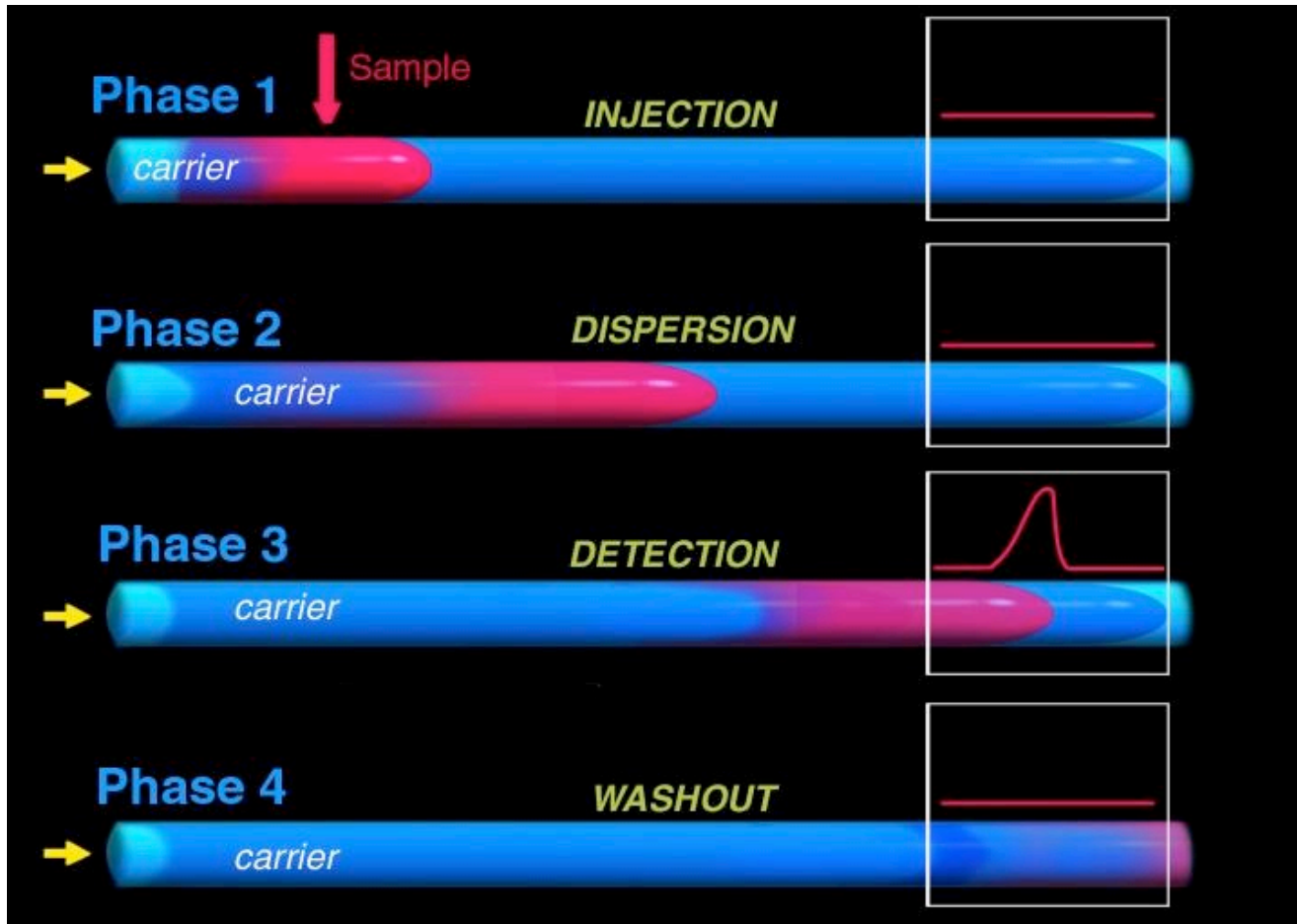

Não é necessário atingir o equilíbrio
mistura amostra e reagente → altamente controlada
→ reprodutiva

Configuração em Linha Única

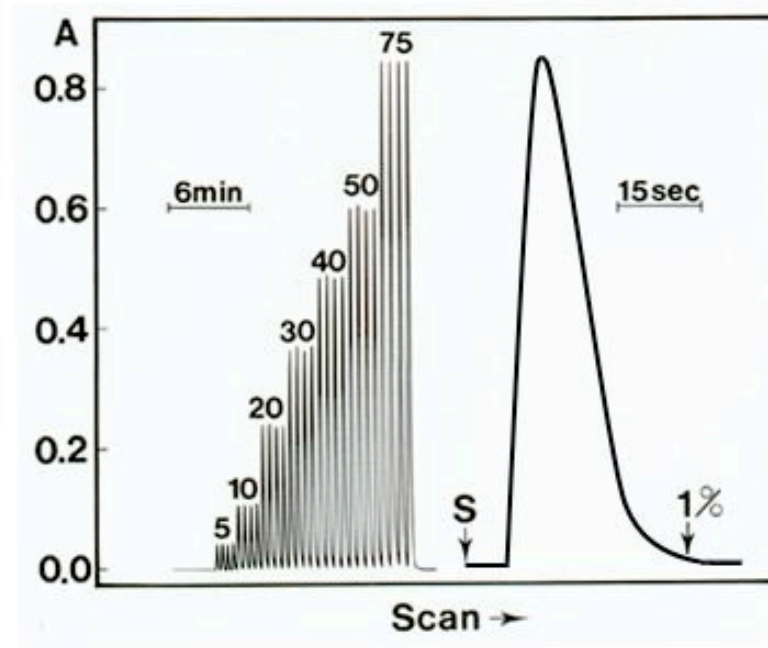
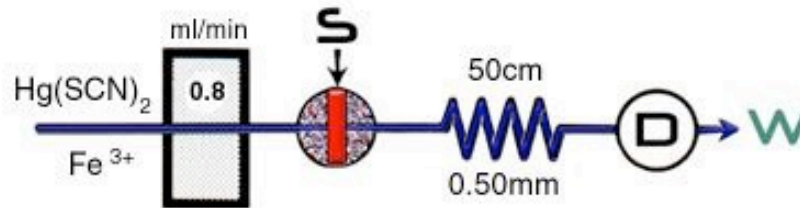
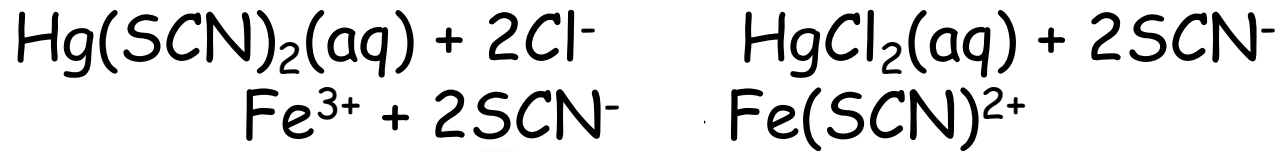

J. Ruzicka, E. H. Hansen, H. Mosbaek, F. J. Krug,
Anal. Chem., 49 (12), 1858, 1977.

Sistema em
linha única

→ interessante quando não
ocorre reação química

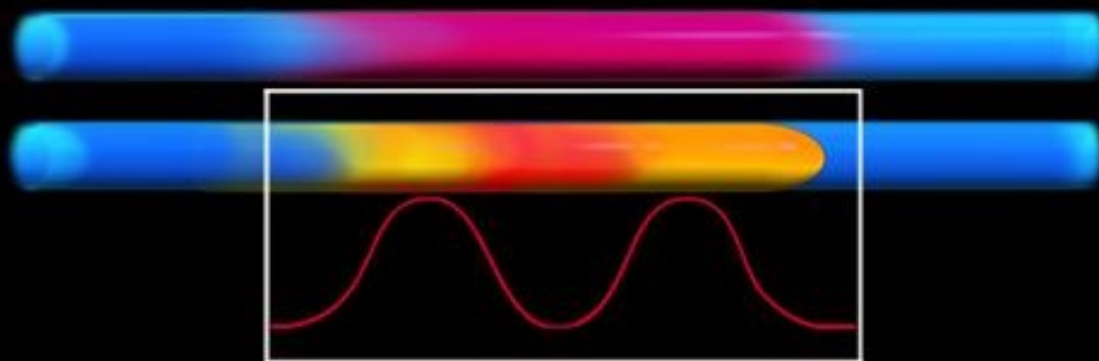
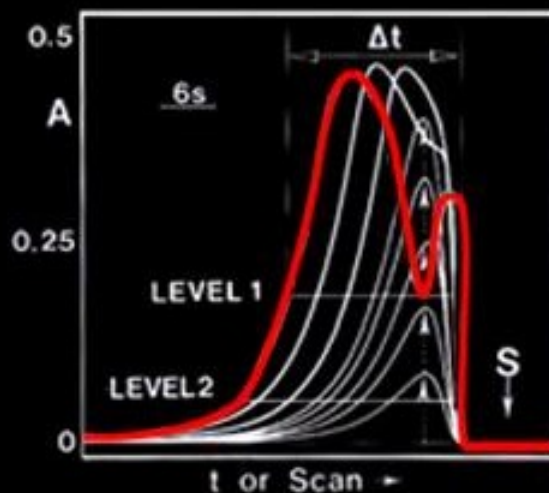

Pico duplo



injeção de volume
grande

Configuração em confluência

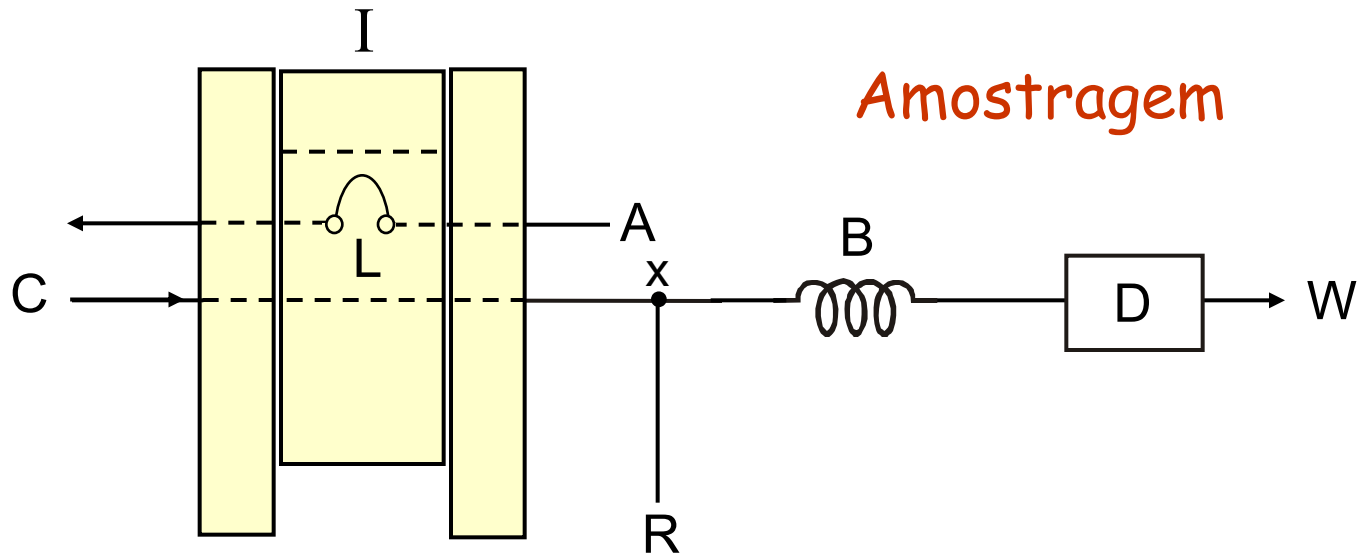
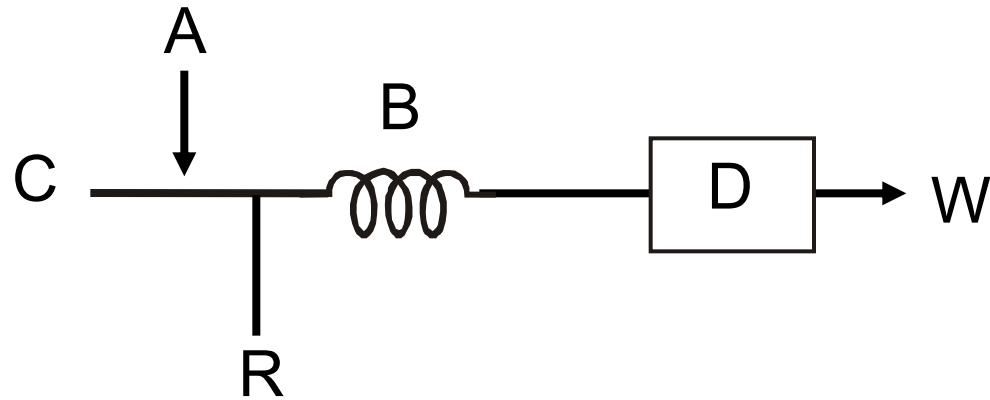

Configuração em confluência

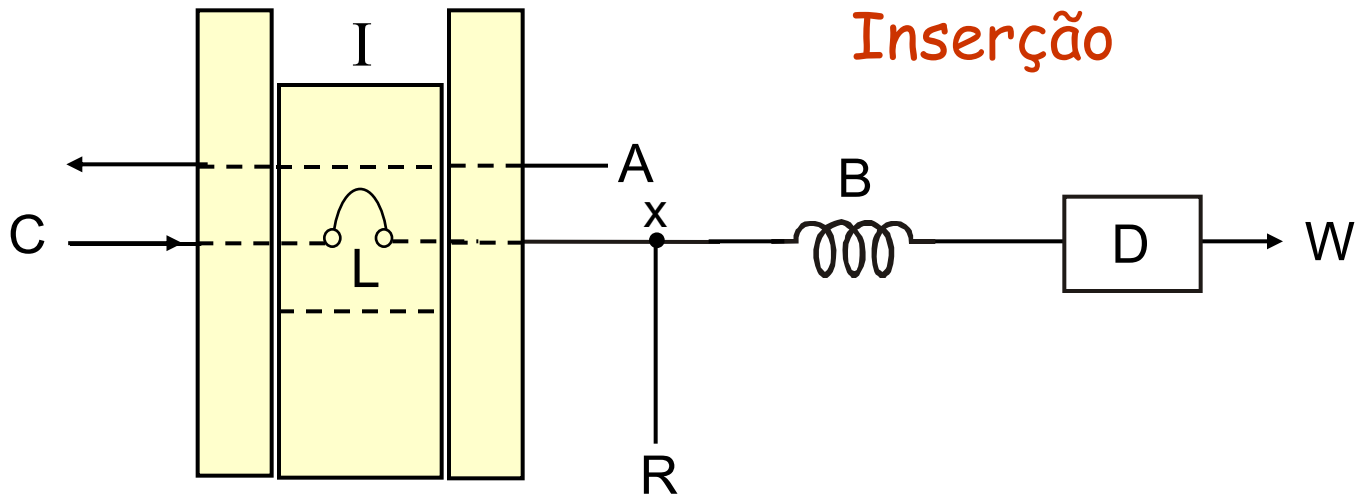
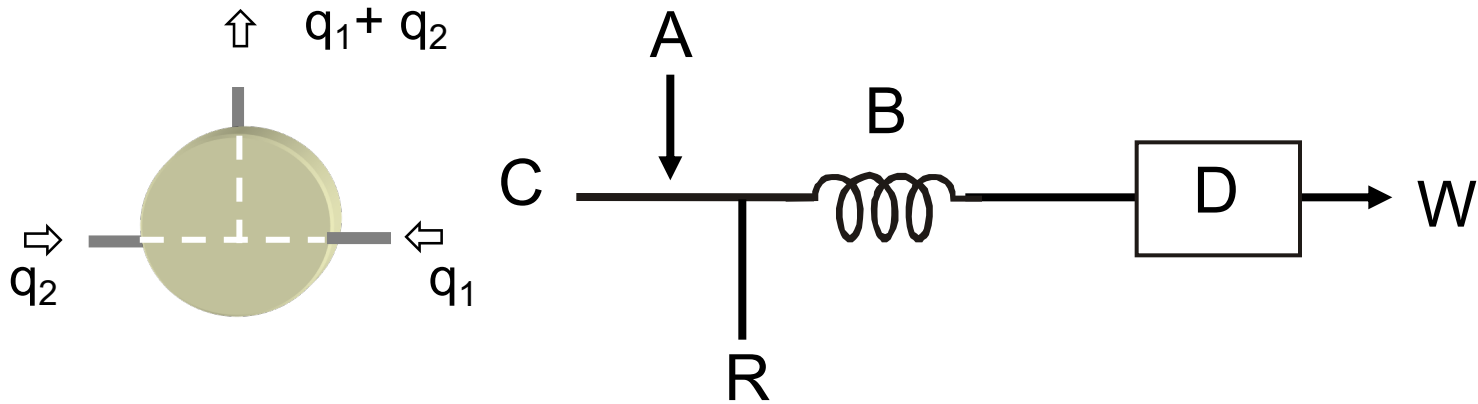

Sistema em confluência

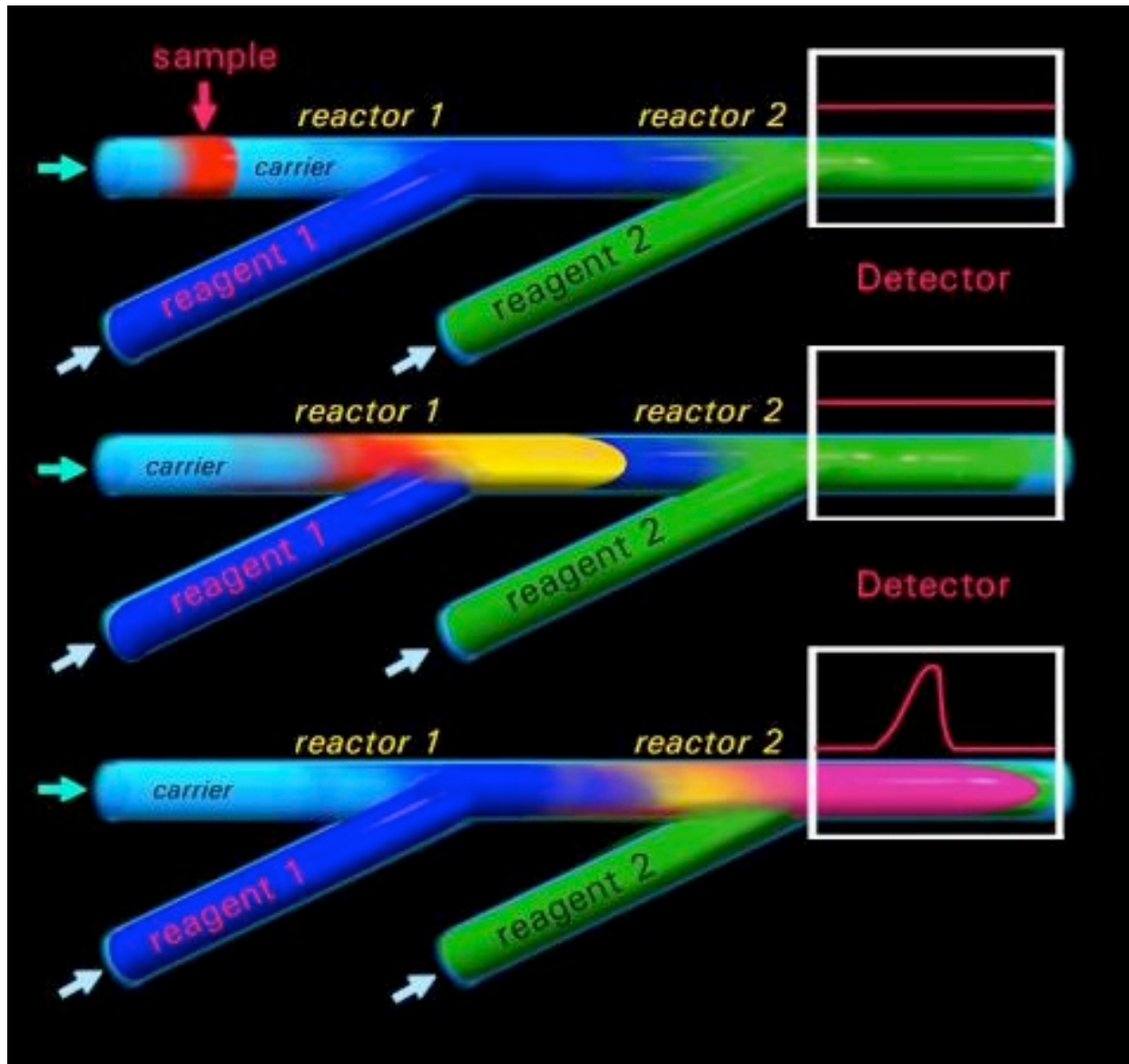

Zonas coalescentes

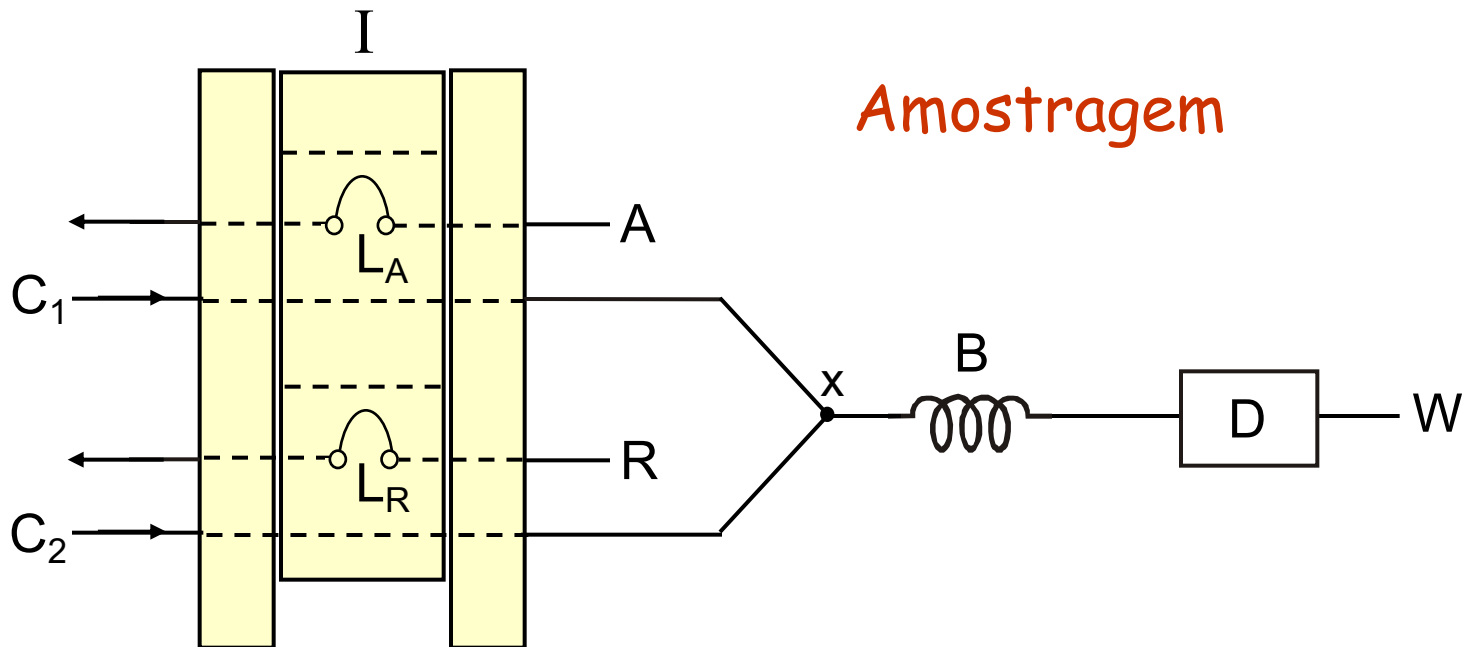
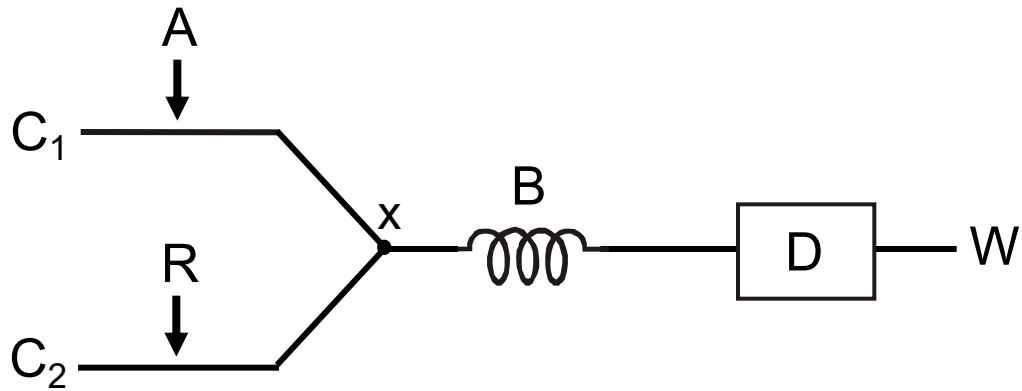

Zonas coalescentes

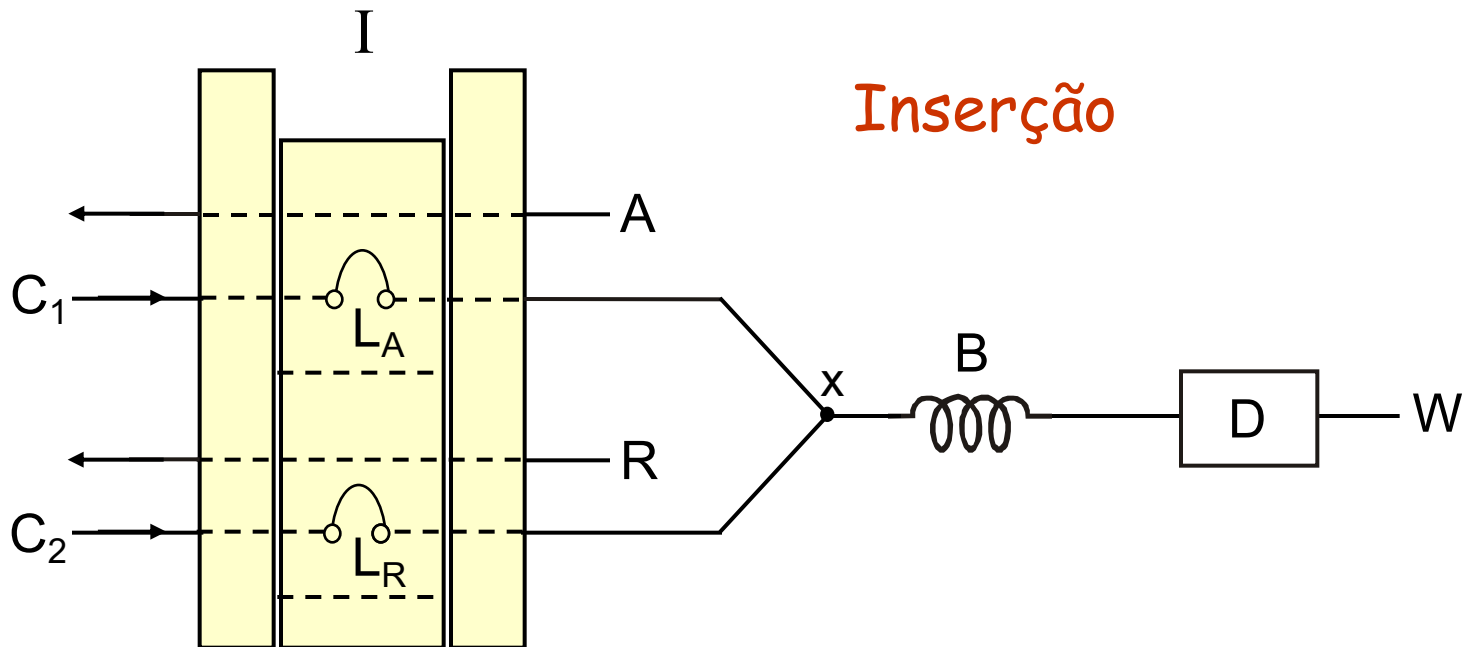
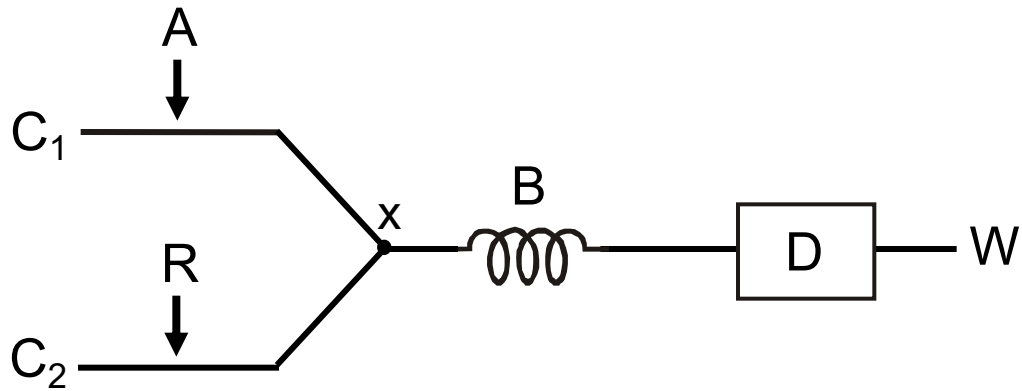

Análise em fluxo monossegmentado (MSFA)

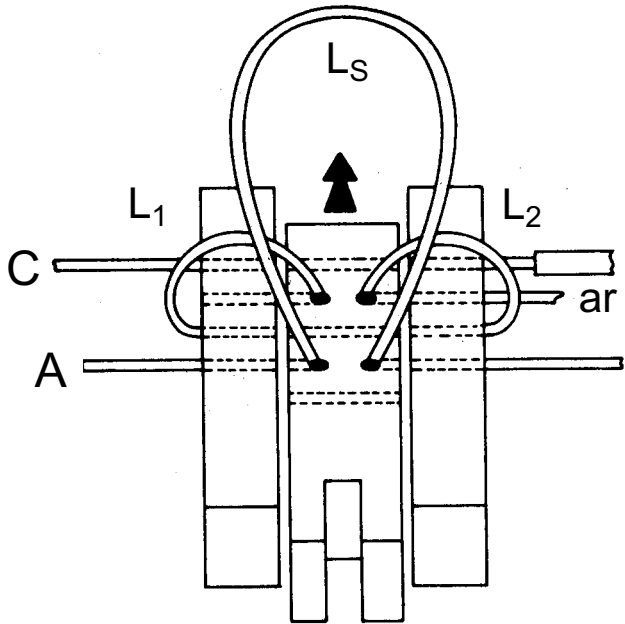

- ⇒ inserção da amostra entre bolhas de ar
- minimizar dispersão longitudinal
 - evitar intercontaminação entre amostras

Pasquini, C.; Oliveira, W.A.; Monosegmented system for continuous flow analysis. Spectrophotometric determination of chromium(VI), ammonia, and phosphorous. *Anal. Chem.*, 57 (1985) 2575.

Análises por Injeção em Fluxo

- ✓ condições de análise altamente reprodutíveis
- ✓ elevada frequência de amostragem
- ✓ minimização do envolvimento do analista
- ✓ minimização de contaminações
- ✓ baixo consumo de reagentes e amostra
- ✓ minimização da produção de resíduos

Evolução dos sistemas FIA

- ✓ simplificação dos módulos de análises
- ✓ implementação de diversos procedimentos
- ✓ sem a necessidade de alteração da sua estrutura física

Histórico

1990 → Análise por injeção sequencial (SIA)

- J. Ruzicka; G.D. Marshall; Sequential injection: a new concept for chemical sensors, process analysis and laboratory assays.

Anal. Chim. Acta, 237 (1990) 329-343.

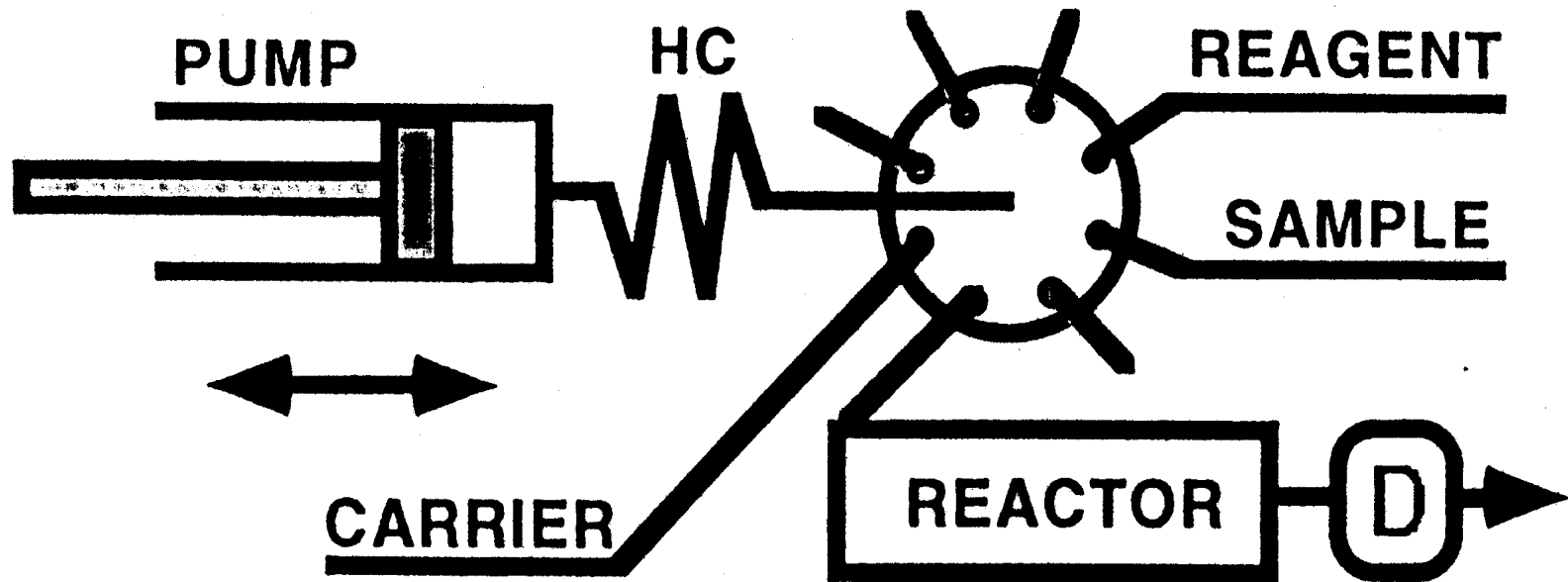



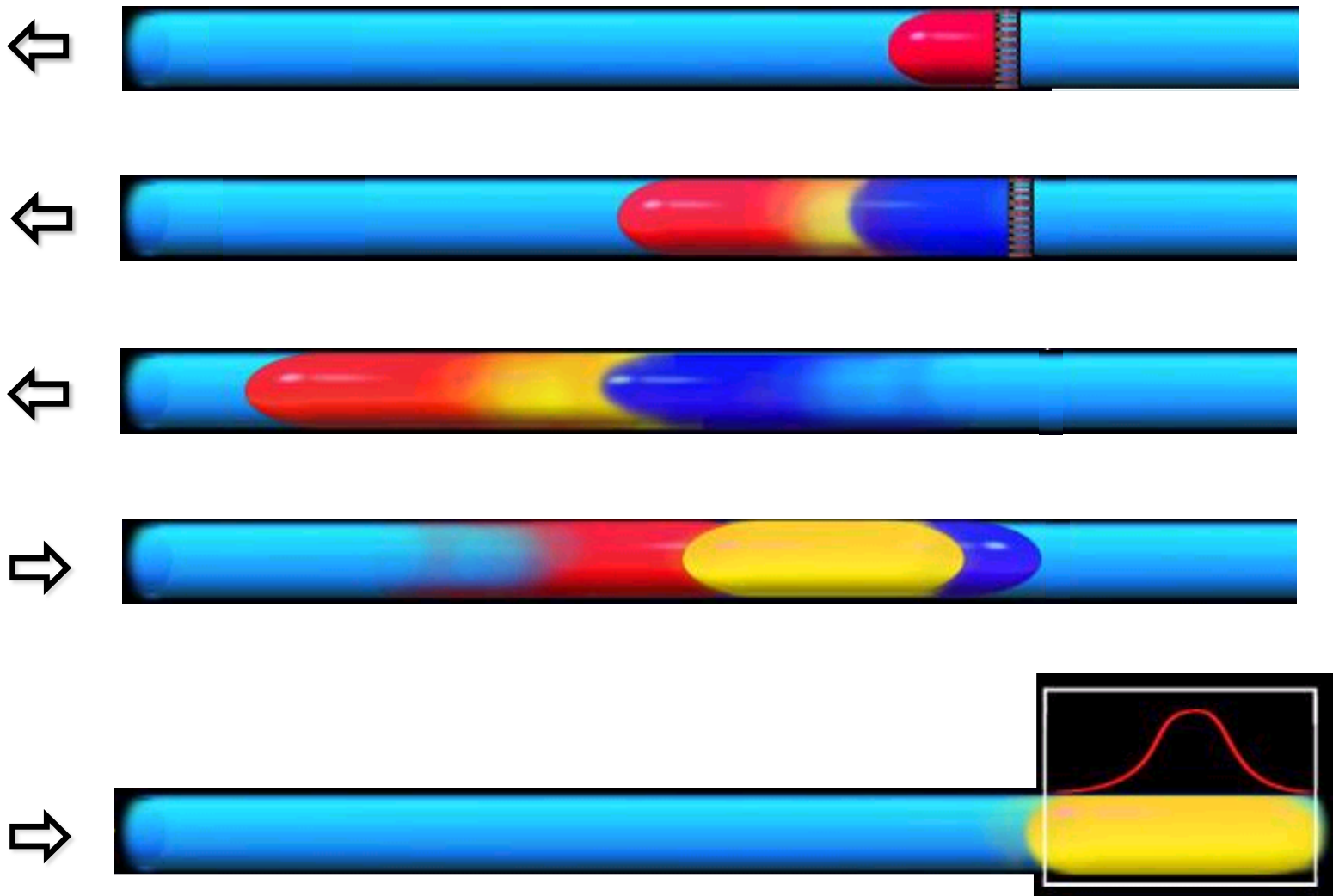

dificuldade de misturas:
volume de alíquotas supera um limite

menor sensibilidade
menor frequência analítica

Evolução dos sistemas FIA.....

Dipositivos empregados para
introdução de amostras e reagentes

Inserção de amostras



Seringa hipodérmica

Injetor proporcional

Válvulas rotatórias

Válvulas solenóides



Multicomutação



Processos
discretos



Comutação



Processo
solidário



Versatilidade

Injetores - FIA

⇒ Seringa hipodérmica

☹ Precisão - amostragem

☹ Vazão - injeção

↑ Impedância hidrodinâmica

⇒ Válvula rotatória

Amostragem

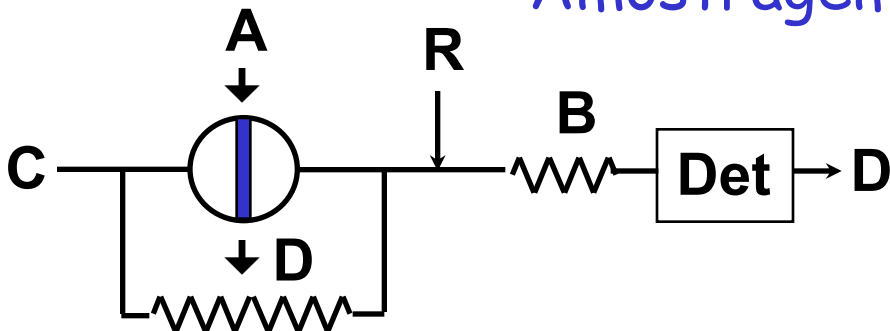

Inserção

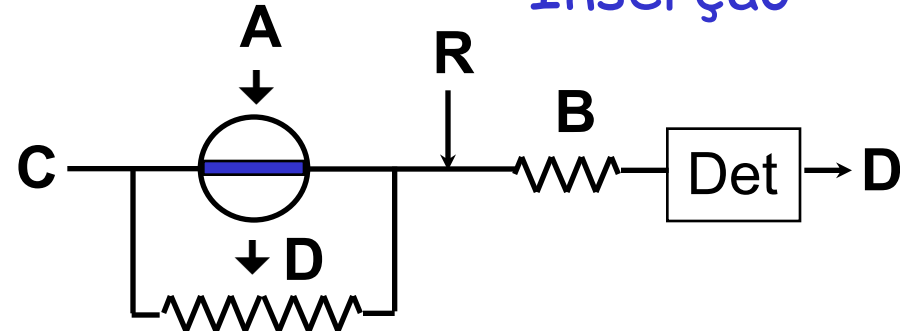

Válvulas rotatórias - 6 vias

Amostragem

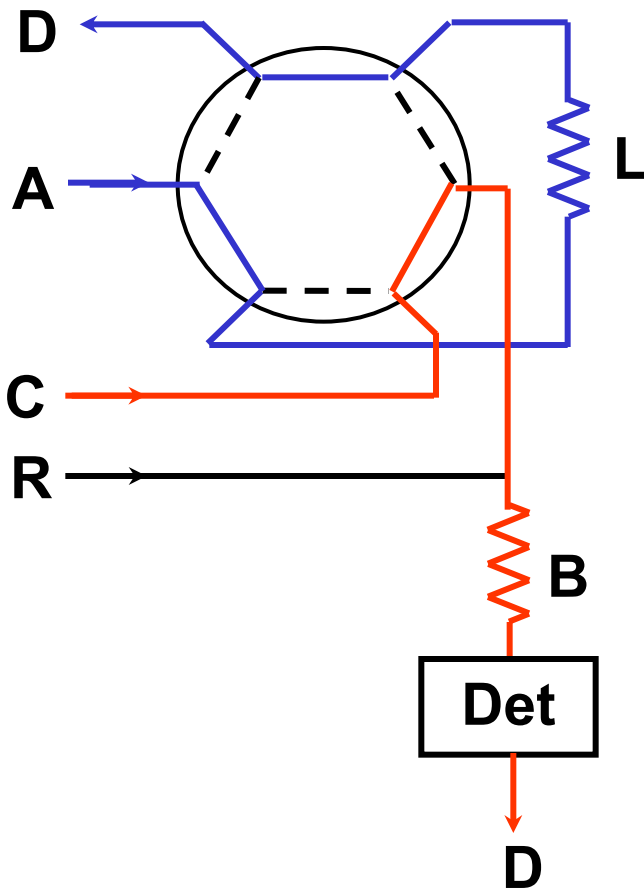

Inserção

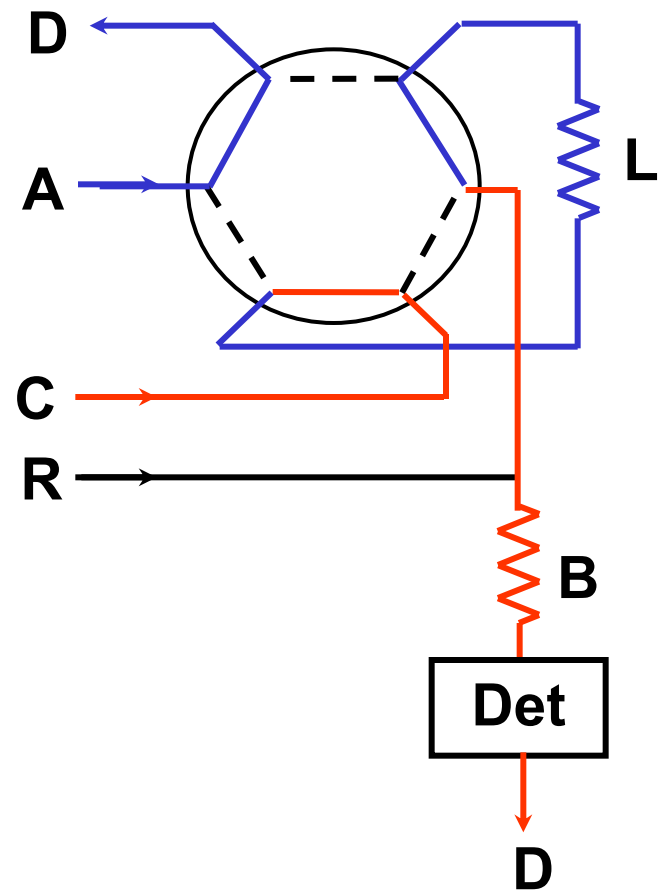

Injetor proporcional

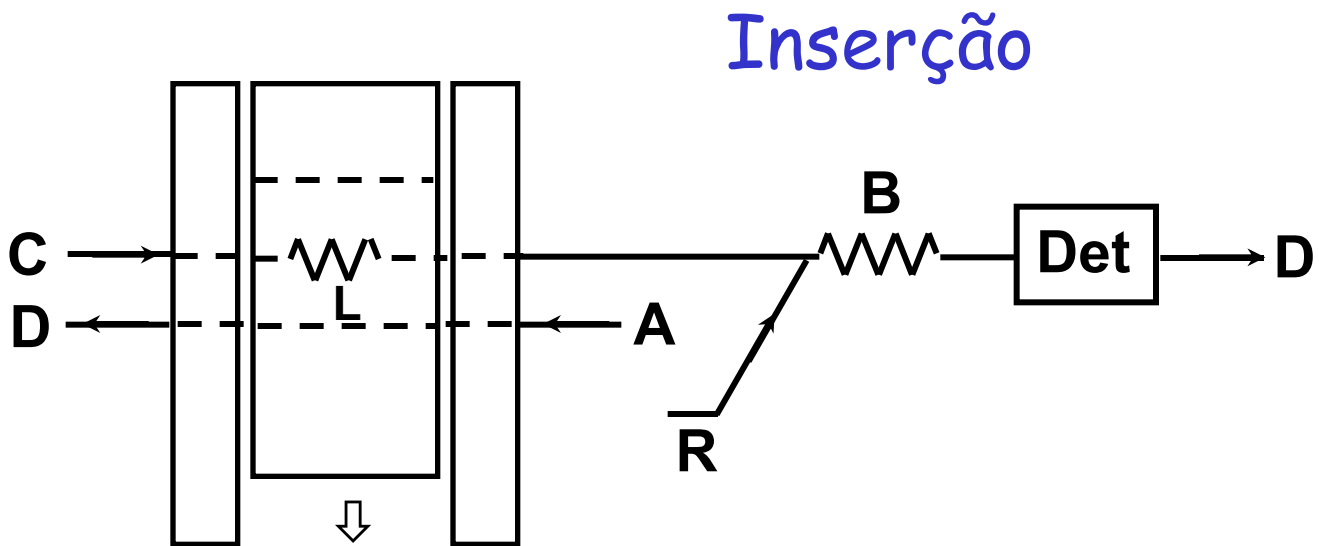
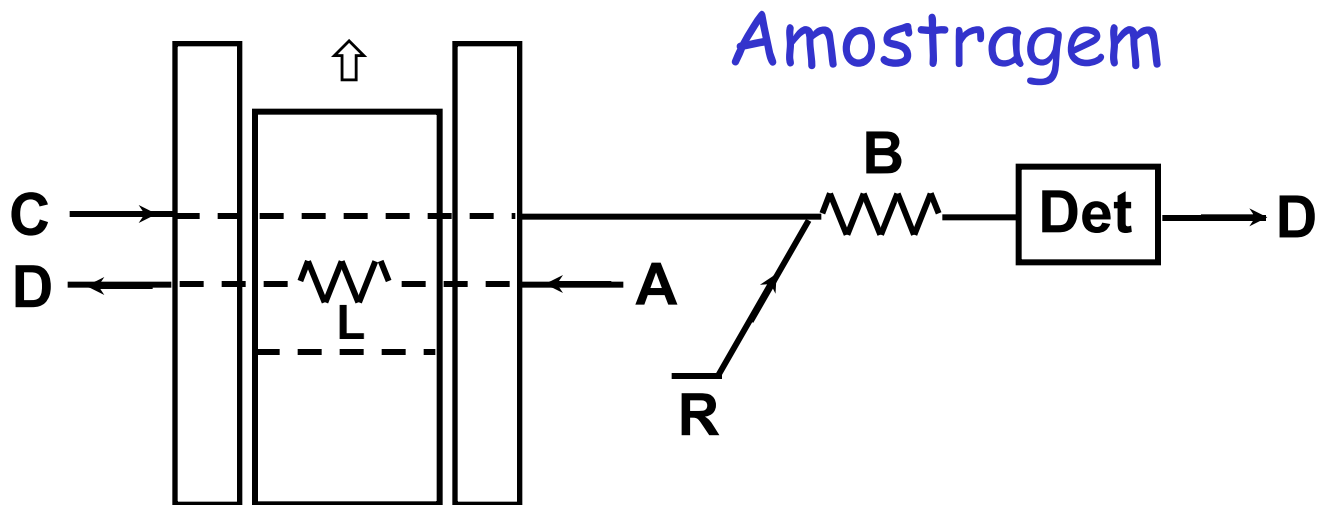

Comutação Solidária

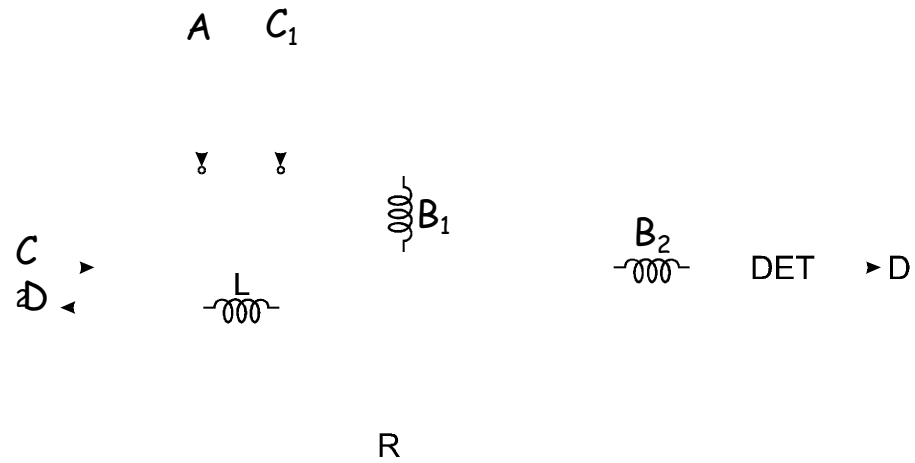

Comutação Discreta

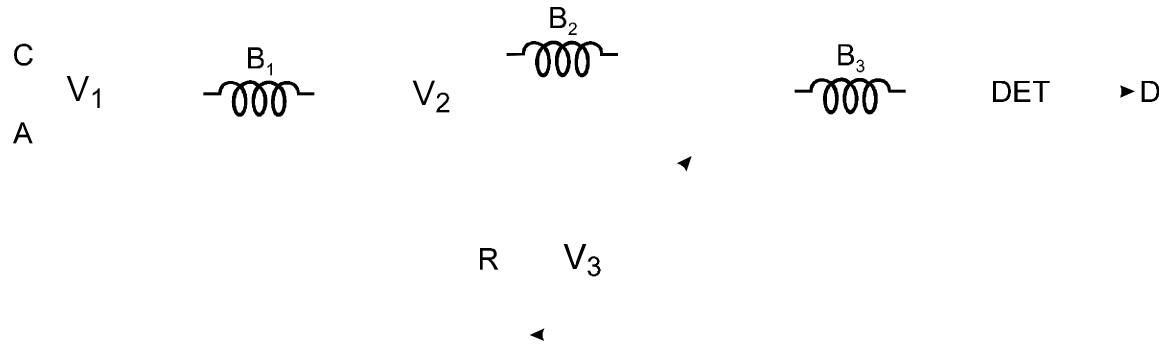

Histórico

1994 → Multicomutação - Amostragem binária

-Reis, B.F.; Giné, M.F.; Zagatto, E.A.G., Lima, J.L.F.C., Lapa, R.A.;
Multicommutation in flow analysis. Part 1. Binary sampling: concepts,
instrumentation and spectrophotometric determination of iron in
plant digests. *Anal. Chim. Acta*, 293 (1994) 129.

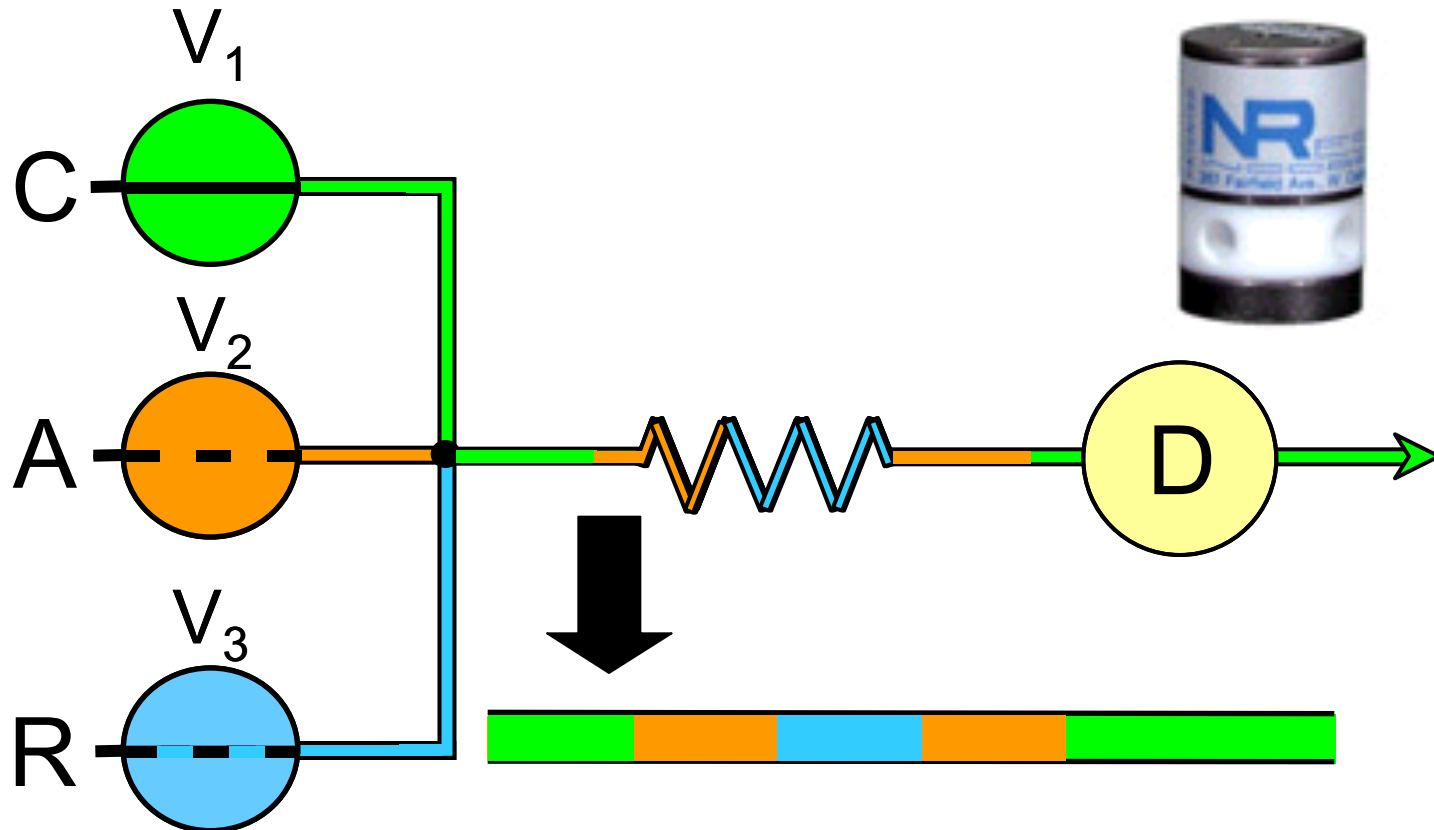

Multicomutação

➡ Dispositivos discretos
- ex: válvulas solenóides



➡ Módulos de análise - estrutura ativa

↑ Versatilidade

• Melhor desempenho analítico

↓ Consumo de reagentes

↓ Geração de resíduos

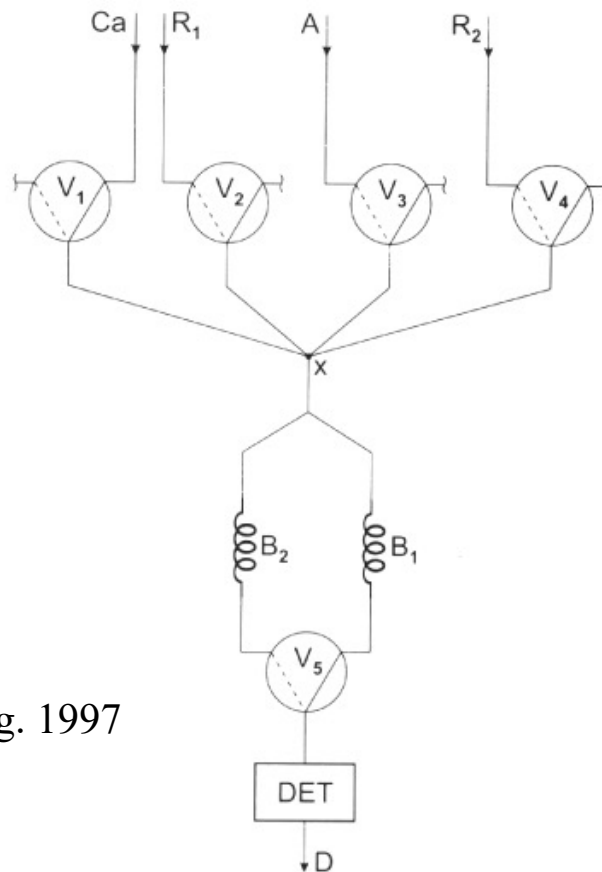

Quím. Nova vol.20 no 4 July/Aug. 1997



Figura 1. Diagrama de fluxo do módulo de análise. Ca = carregador da amostra; A = amostra; R₁ = molibdato de amônio 1,0% (m/v); R₂ = ácido ascórbico 1,0 % (m/v); B₁ e B₂ = bobinas de reação de tubo de polietileno, 100 cm de comprimento, 0,8 mm de diâmetro interno; DET = espectrofotômetro (640nm); D = descarte; V₁, V₂, V₃, V₄ e V₅ = válvulas solenóides de 3 vias. T₁, T₂, ..., T₅ = intervalos de tempo de acionamento das válvulas V₁, V₂, ..., V₅; T_{A1} e T_{A2} = intervalos de tempo para leitura dos sinais correspondente às zonas de amostras dos percurso analíticos B₁ e B₂, respectivamente.

Consumo de reagentes - Determinação de cloreto

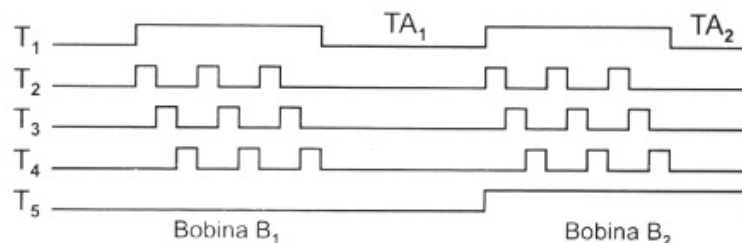
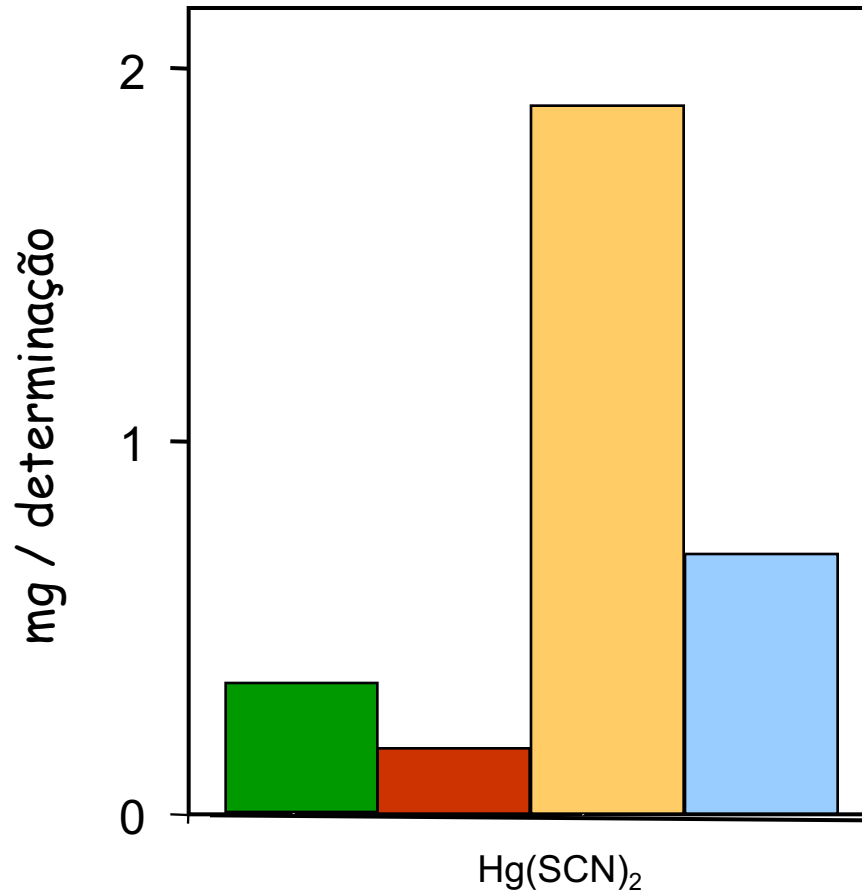

Análise por
injeção
seqüencial

Amostragem
binária

Adição por
confluência

Procedimentos
em batelada

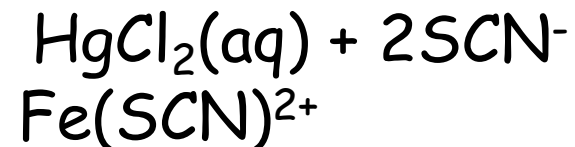
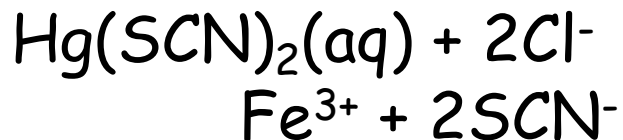

Consumo de reagentes - Determinação de nitrato

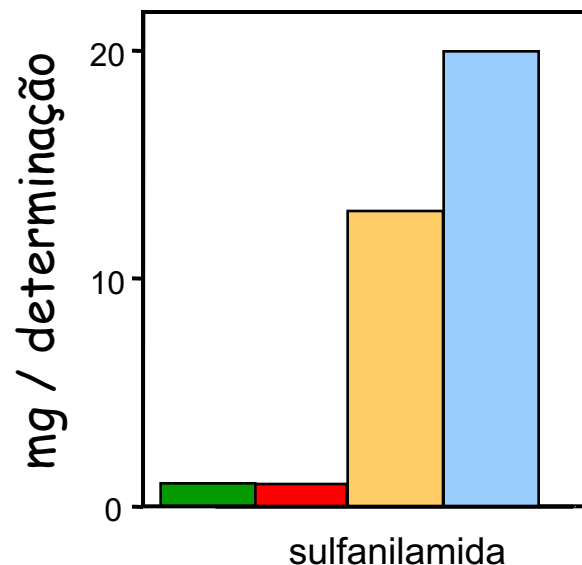
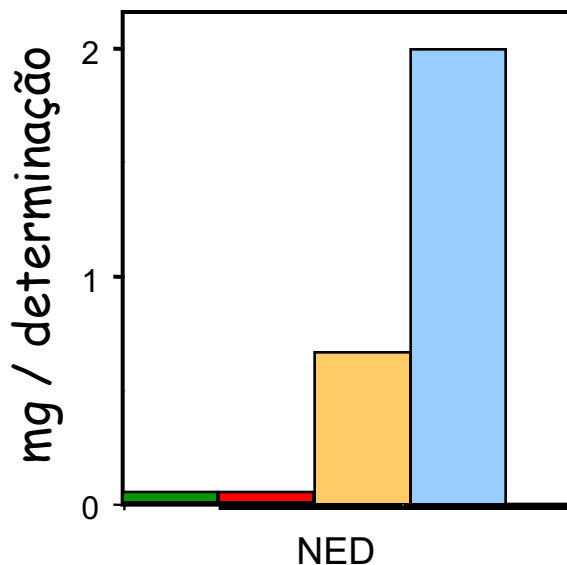

NED = n-naftil-etilenodiamina

Análise por
injeção
seqüencial

Amostragem
binária

Adição por
confluência

Procedimentos
em batelada

Consumo de reagente na determinação de fosfato em diversos sistemas de análises em fluxo

Sistemas de análise em fluxo	Consumo de $(\text{NH}_4)_6\text{Mo}_7\text{O}_{24}\cdot 4\text{H}_2\text{O}$ (mg/med)
Linha Única	2,40
Confluência	2,10
SIA	1,60
Zonas Coalescentes	0,90
Multicomutação	0,90
Batelada	47,8

Sistemas de análise por injeção em fluxo

- 😊 fáceis de serem automatizados;
- 😊 fáceis de controlar no espaço e no tempo;
- 😊 não há evaporação dos líquidos (sistema fechado)
- 😊 são muito versáteis:
 - os fluxos podem ser misturados, parados, reiniciados, revertidos, divididos e amostrados;
- 😊 possibilidade de análise simultânea de vários analitos;
- 😊 baixo custo

Aplicações em sistema FIA

"Theory guides, experiment decides"
I.M. Kolthoff

Gostaria de saber se é possível fazer
análise de N-P-K em fertilizantes?

.....Sim, são muitas

.....

Eu preciso dos resultados rapidamente

Problema Analítico: 😞 determ. de N-P-K em fertilizantes

Métodos Manuais:

👉 Dificuldade de manuseio das soluções

👉 Tempo ✈ ✈ 🕒

👉 necessidade do resultado com elevadas precisão e
exatidão analítica

Solução.....

Problema Analítico

😊 Análise por injeção em fluxo (FIA)

👉 Determinação sequencial de N-P-K

👉 exploração de separações físico-químicas

👉 👉 emprego de mais de um detector

DETERMINAÇÃO SEQUENCIAL DE N-P-K EM
FERTILIZANTES: REMOÇÃO SERIAL DE
ANALITOS EM SISTEMAS FIA

“Sequential analyte removal in flow analysis:
determination of nitrogen, phosphorus and
potassium in fertilizers”

P.B.Martelli...

Analytica Chimica Acta, 317 (1995) 239-245

REMOÇÃO SERIAL

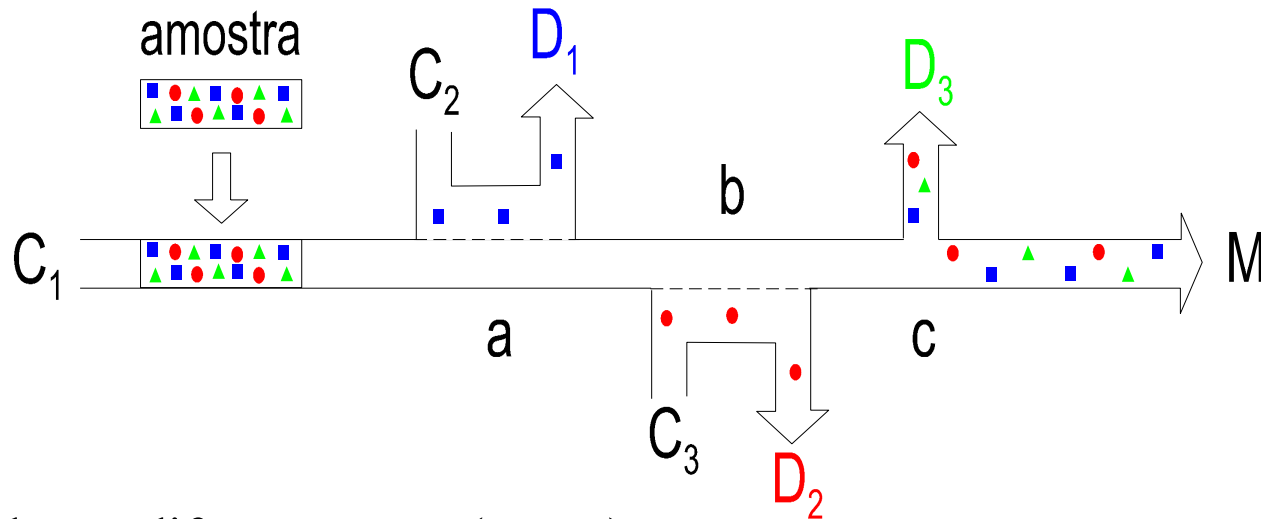

$D_1 \Rightarrow$ • Membrana difusão gasosa (PTFE) $\rightarrow a$

- Eletrodo tubular de membrana polimérica sensível ao íon amônio



$D_2 \Rightarrow$ • Membrana diálise “C” EZEE-MOUNT $\rightarrow b$

- Fotômetro de chama



$D_3 \Rightarrow$ • Divisor de fluxos $\rightarrow c$

- Espectrofotometria de absorção molecular

☺ ☺ **M** \rightarrow outras determinações

Difusão gasosa

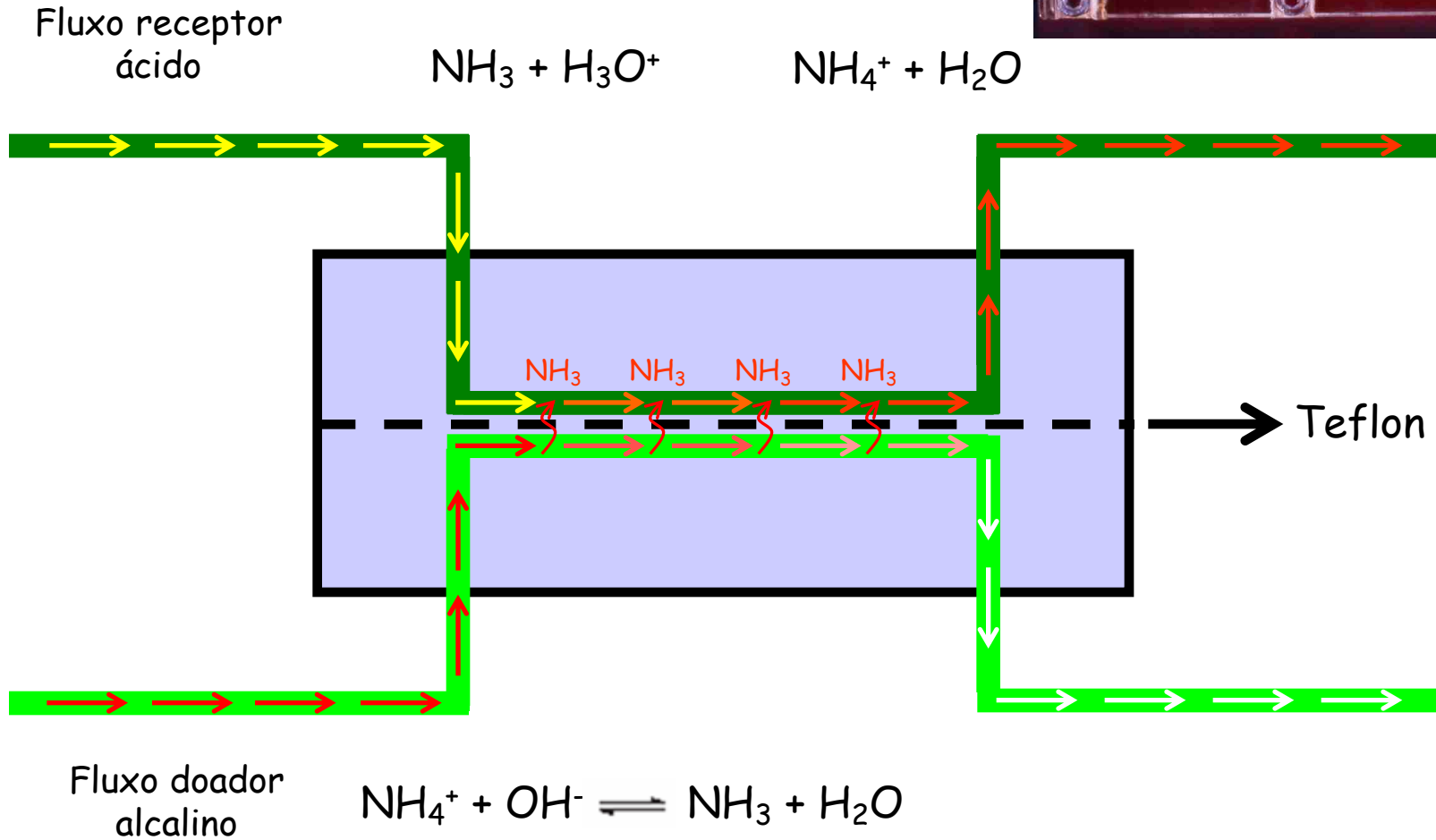
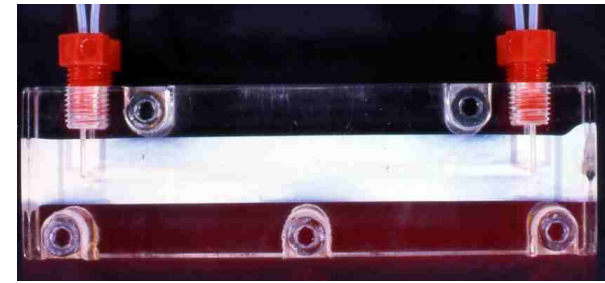

Sistema FIA para determinação de N-P-K

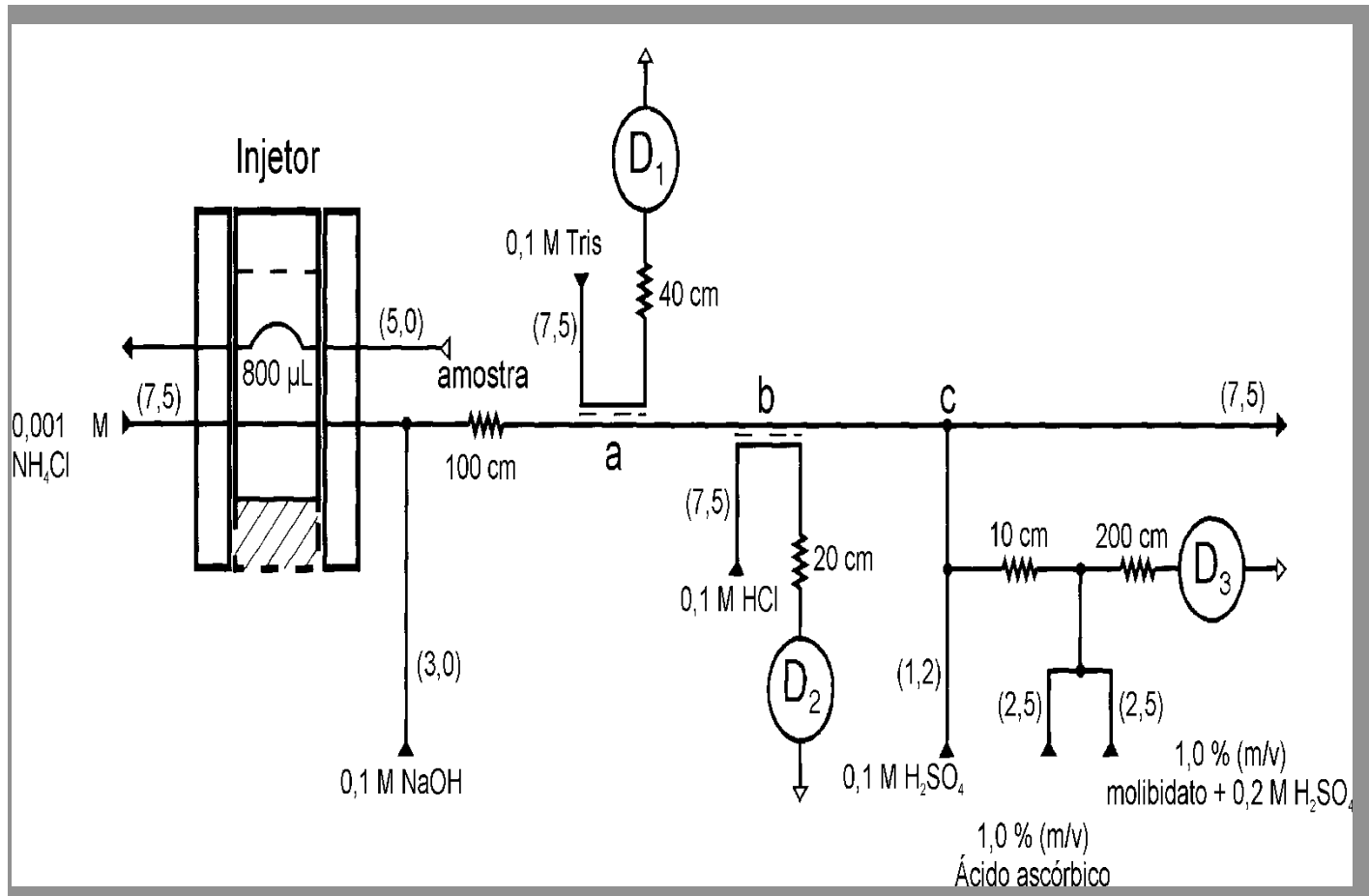

Análise de rotina em amostras de fertilizantes

Comparação dos resultados

amostra %(m/m)	amônio		fósforo		potássio	
	A	B	A	B	A	B
1	3,21(2,3)	3,40(2,7)	15,92(1,5)	16,31(2,5)	18,43(1,7)	17,97(1,6)
2	5,67(1,4)	5,72(2,4)	6,37(1,9)	6,12(3,5)	4,62(2,3)	4,83(1,8)
3	4,52(1,5)	4,65(2,4)	19,84(1,5)	19,75(2,2)	6,32(1,9)	6,47(1,7)
4	3,57(1,5)	3,46(2,7)	1,64(3,1)	1,83(3,8)	7,92(1,9)	7,89(1,8)
5	5,08(1,4)	4,90(2,4)	4,42(2,2)	4,47(3,0)	2,11(2,5)	2,25(2,1)
6	2,54(2,6)	2,65(3,4)	2,98(2,4)	2,85(3,5)	3,42(2,3)	3,42(1,8)
7	2,83(2,6)	2,85(3,4)	1,93(2,8)	1,91(3,5)	9,41(2,0)	9,38(1,7)
8	4,05(1,3)	4,05(2,5)	17,88(1,6)	18,03(2,5)	5,45(2,3)	4,97(1,8)

A - método proposto B - método oficial ("batch") () - r.s.d

Características analíticas

- Alta versatilidade
- Diversos detectores
- Alta seletividade
- Resultados concordantes com os métodos oficiais
- 225 determinações por hora (75 amostras)
- Desvio padrão relativo < 3,0 %

Sistema FIA com pré-concentração

Amostras de interesse ambiental
baixas concentrações

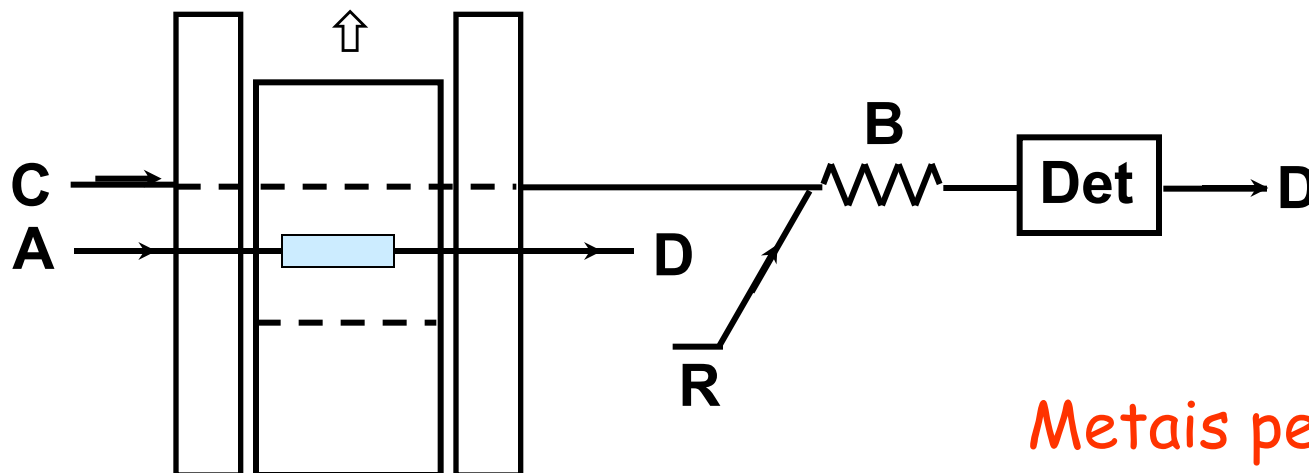

Metais pesados
 PO_4^{3-} , NH_4^+ ,
 NO_3^- , SO_4^{2-}

Resinas: aniônica (Bio-Rad, AG1-X8)
catiônica (Bio-Rad, AG 50W-X8)
íon quelante (Bio-Rad, Chelex 100)

Sistema FIA para diluição "on-line"

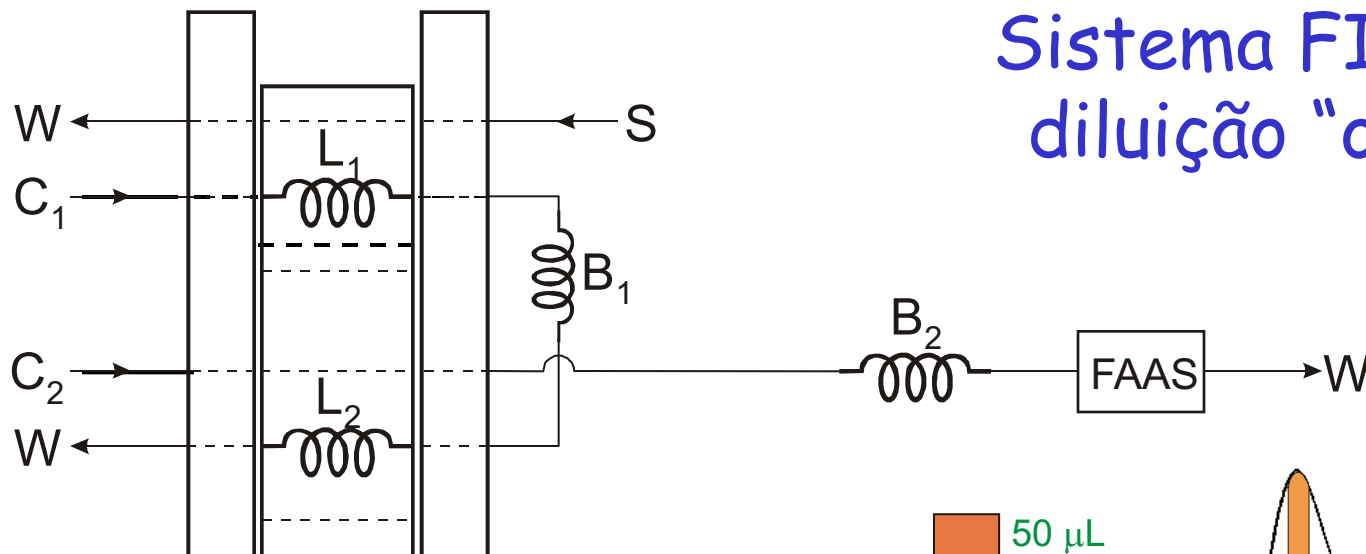

Reamostragem (Zone-Sampling)

Amostras com altas concentrações

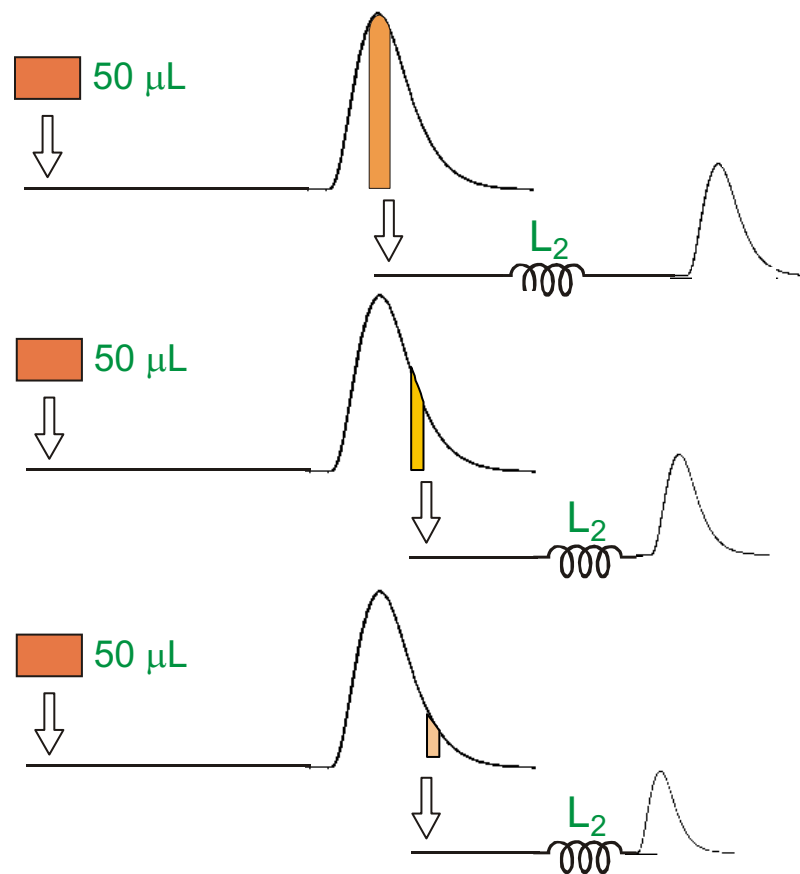

Sistema automático - diluição

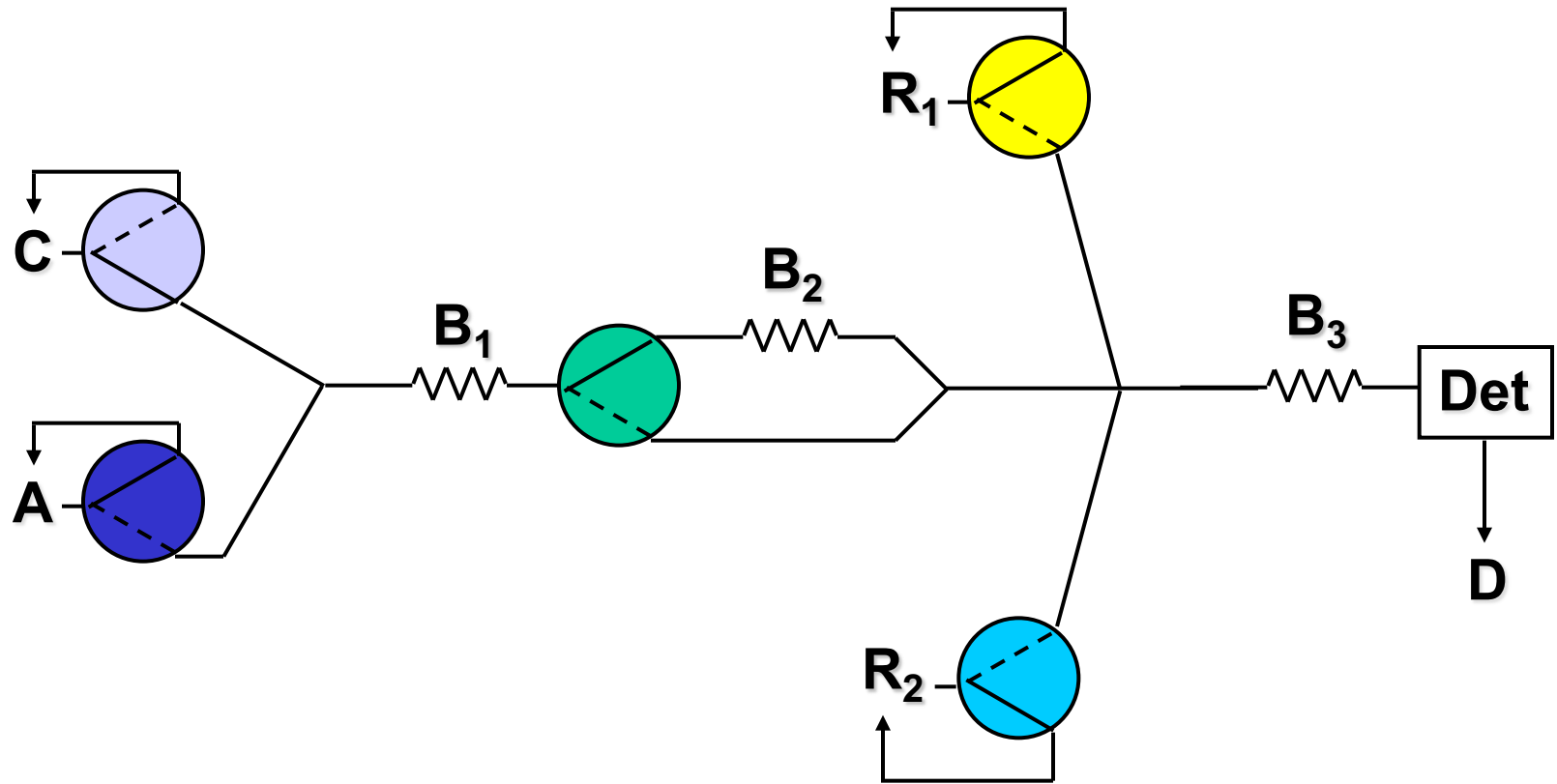

Automatic multicommutation flow system for wide range spectrophotometric calcium determination.

Anal.Chim.Acta, 366 (1998) 45-53.

- 3,3' -bis[N,N-bis(carboximetil)aminometil]-o-cresolftaleína (CPC)

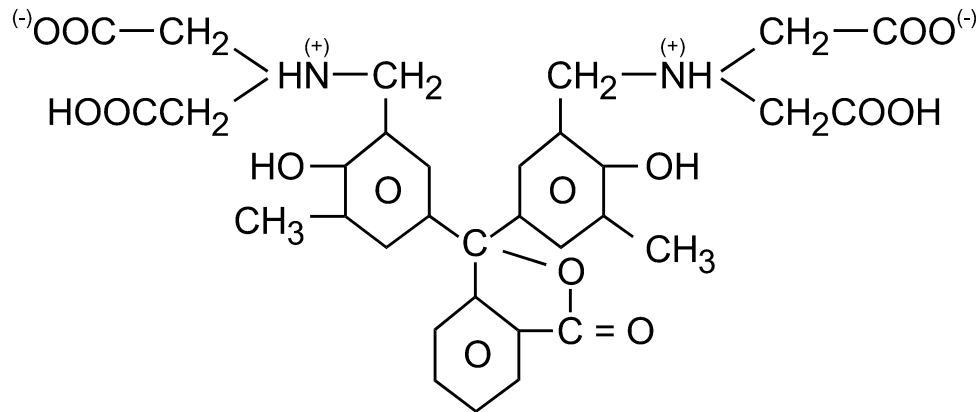

- reação pH 10,5 - tampão: NH₃/NH₄⁺
- 8-hydroxiquinolina: mascarar Mg²⁺
- trietanolamina: mascarar Fe³⁺ e Al³⁺
- amostras: águas, fertilizantes, plantas, rochas calcárias, antiácidos

Características analíticas

- Sistema FIA simples e versátil para diluição automática
- 0,250 - 1000 mg/L Ca²⁺
- Limite de detecção: 7 µg/L Ca²⁺ (99,7 % confidence level)
- Desvio padrão relativo < 0,83 % (n = 10)
- 60 determinações por hora
- Consumo de reagentes: - 0,27 µg CPC - 0,53 mg 8-hydroxiquinolina - 4,5 mg trietanolamina

Problema analítico:

determinação simultânea de Cu e Zn em plantas

Solução:

métodos cinéticos diferenciais



Procedimentos:

- divisor de fluxos
- variação do percurso analítico

Discriminação cinética

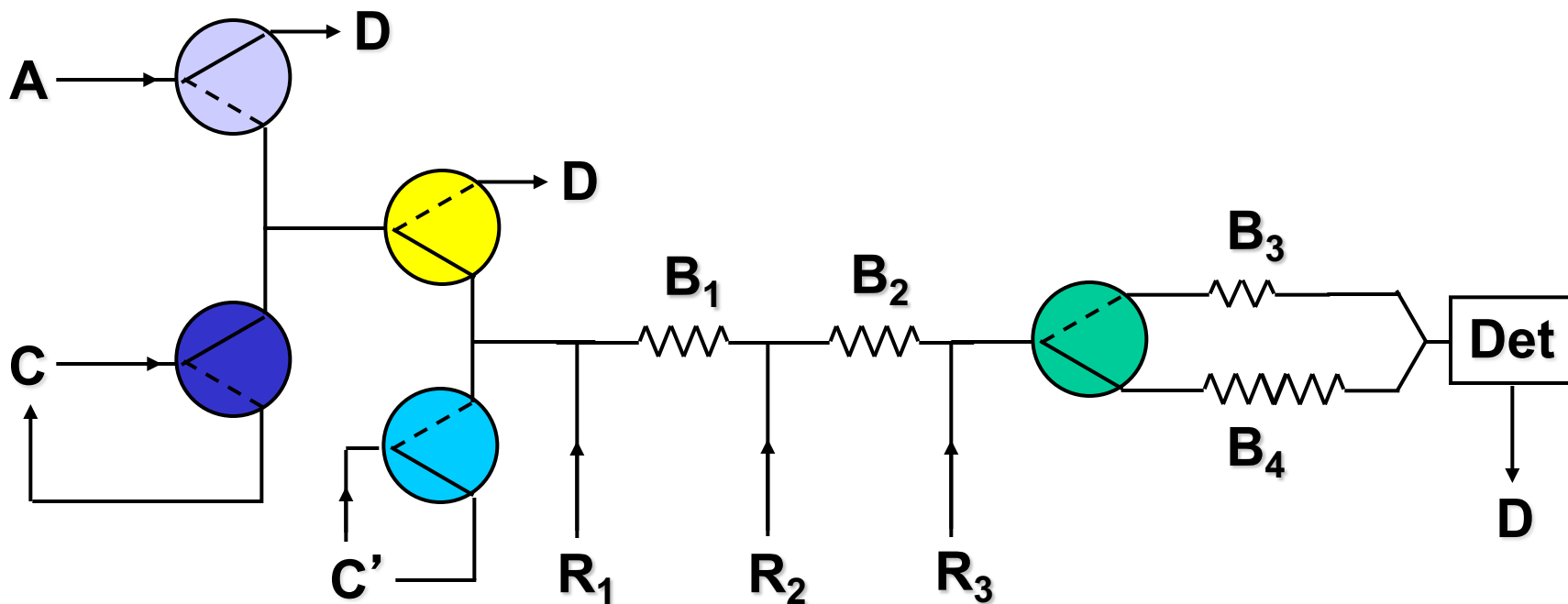

Multicommutation in flow analysis. Part 4. Computer-assisted splitting for spectrophotometric determination of copper and zinc in plants. *Anal. Chim. Acta*, 332 (1996) 173.

Determinação de fenóis totais

(aumento da sensibilidade - aumento do caminho óptico da cela de medida)

- 4-aminoantipirina

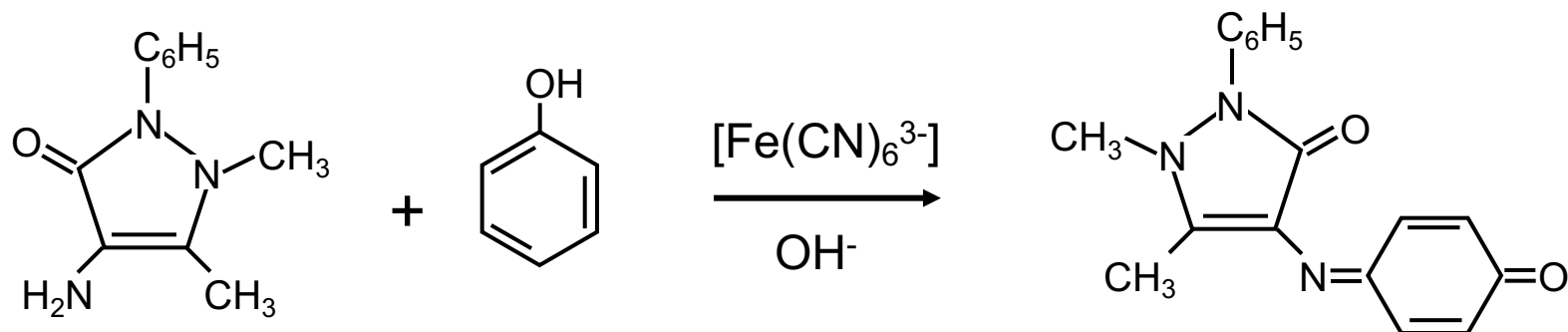

- Guias de ondas
- Fluoropolímero amorfo (Teflon AF-2400[®])
- Empregados para construção de celas com caminho óptico de até 500 cm

Determinação de fenôis totais

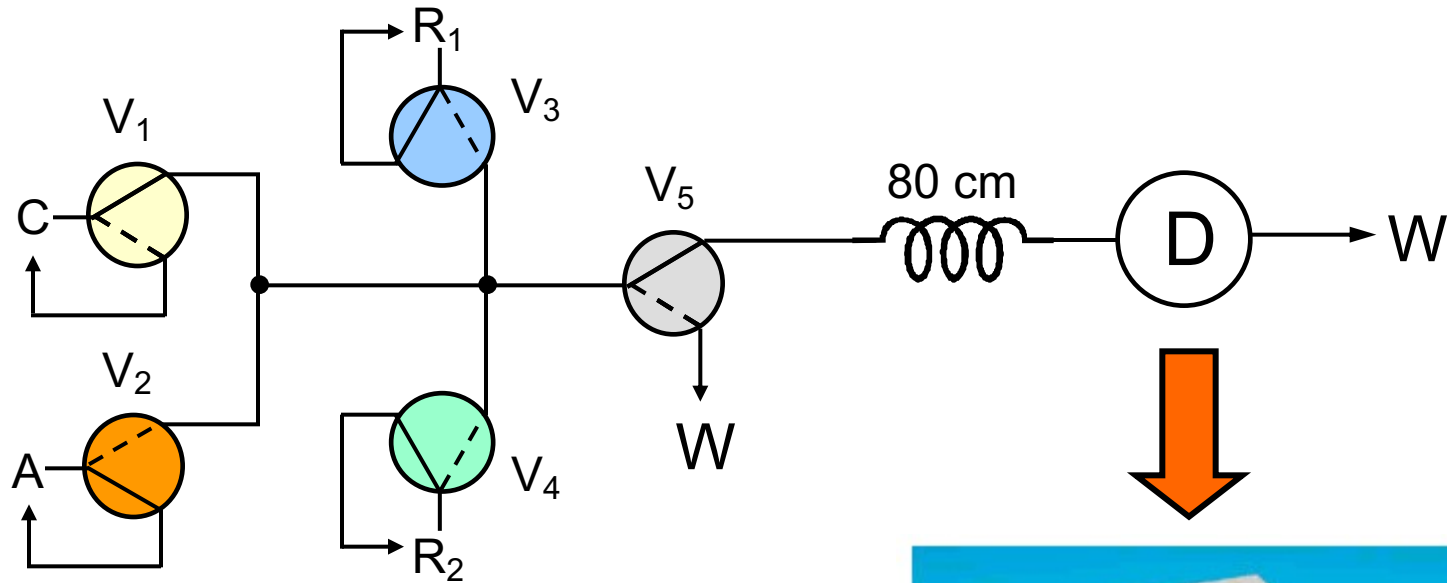

Determinação de fenóis totais

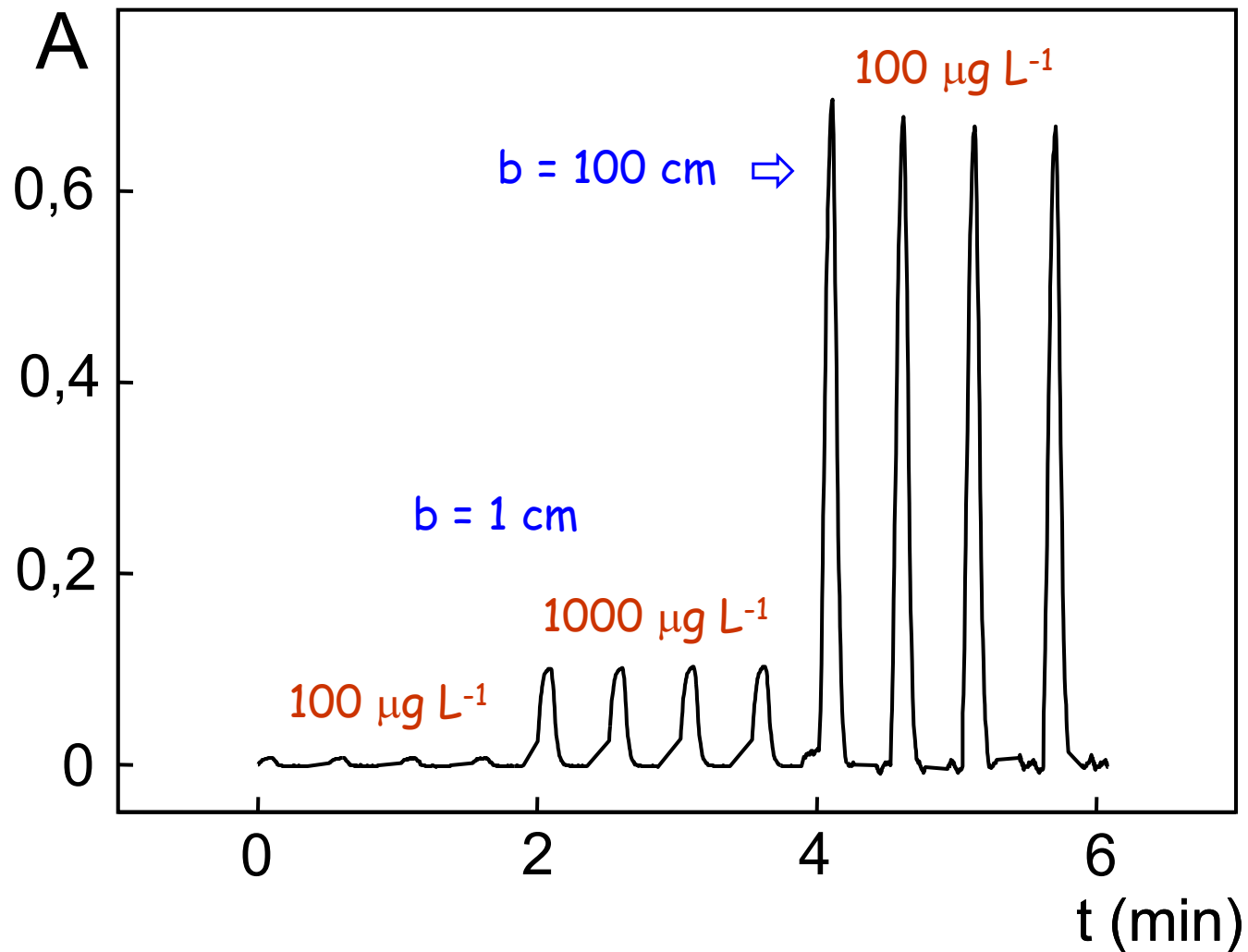

Multicomutação - aplicações

- 😊 Determinações sequenciais
- 😊 Sistemas polivalentes
- 😊 Sistemas auto-otimizáveis
- 😊 Sistemas automáticos
- 😊 Titulações por procura binária
- 😊 Diluições controladas
- 😊 ... 😊 ... 😊 ... 😊 ...

Multicomutação

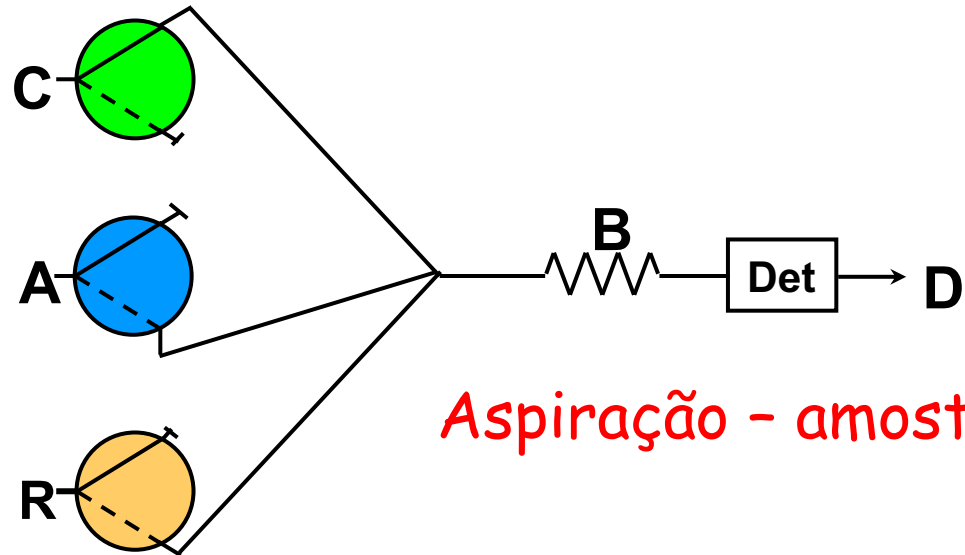

Aspiração - amostragem binária

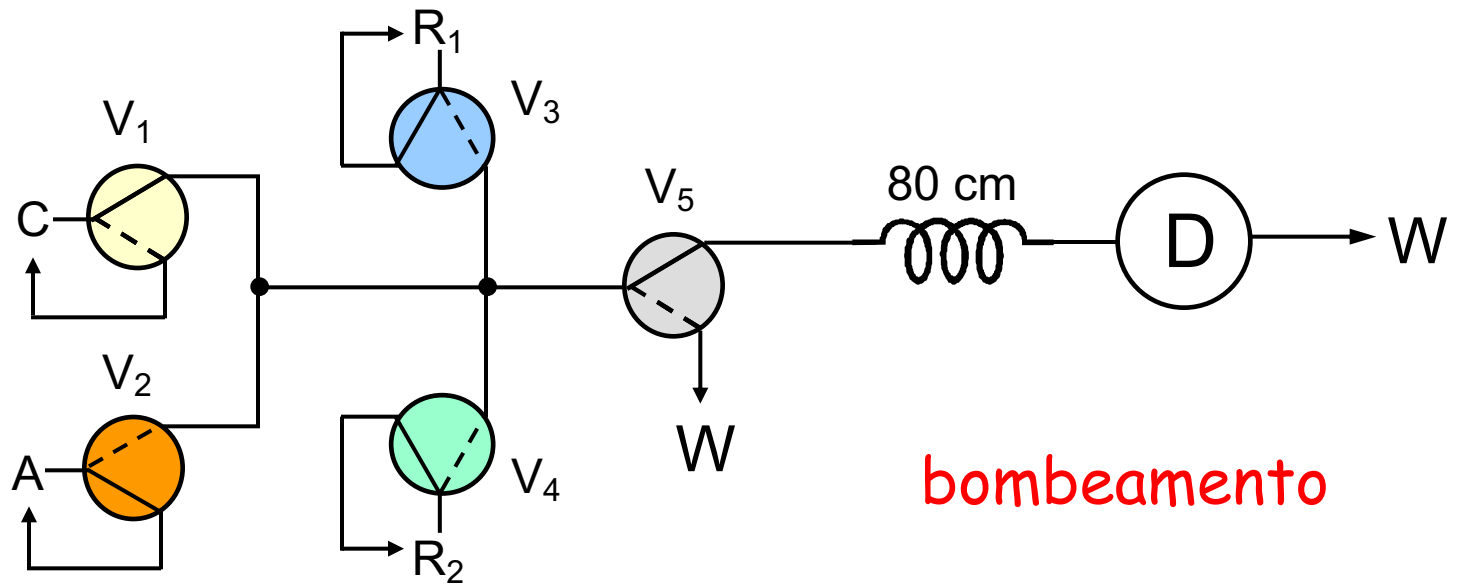

bombeamento

Modo: aspiração

- ✓ Mono-canal
- ✓ Fácil de operar e controlar
- ✓ Alta versatilidade
- ❖ Pressão negativa
- ❖ Baixa vazão

Modo: bombeamento

- ✓ Vários canais de bombeamento
- ✓ Pressão positiva
- ✓ Vazão alta
- ❖ Solução re-circulando
- ❖ Versatilidade limitada

Multicomutação

➔ Searching for a propelling device...

Características e objetivos:

- Pressão positiva
- Controle e operação individual
- Custo operacional baixo
- Tamanho pequeno e altamente portátil
- Específico para cada solução
- Fácil de re-configurar o diagrama
- Diagrama altamente versátil

Histórico

2002 → Mini-bombas solenóides

- Lapa, R.A.S.; Lima, J.L.F.C.; Reis, B.F.; Santos, J.L.M.; Zagatto, E.A.G.;
Multi-pumping in flow analysis: concepts, instrumentation,
potentialities. *Anal.Chim.Acta*, 466 (2002) 125.



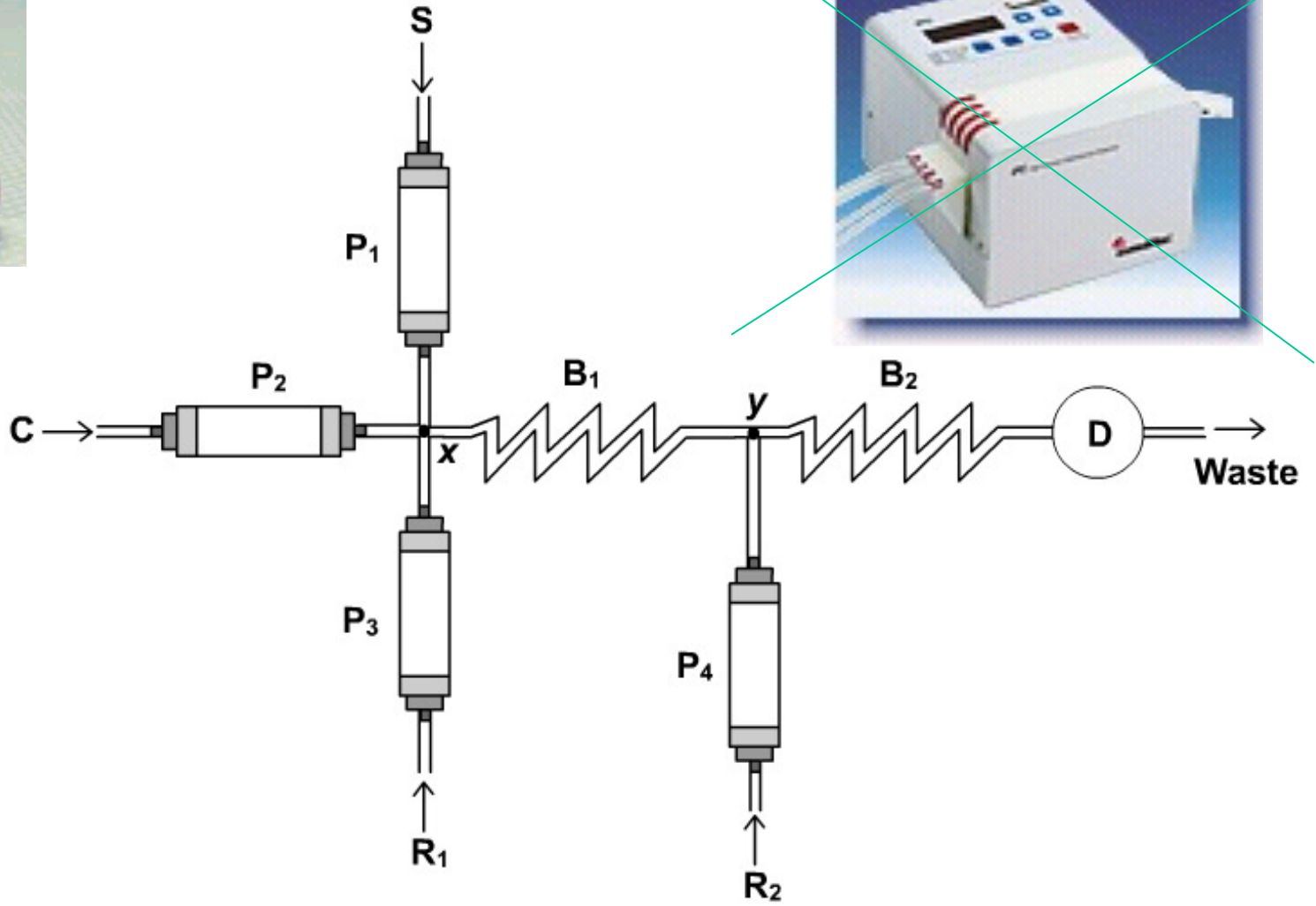



Available online at www.sciencedirect.com



Microchemical Journal 85 (2007) 209–213

MICROCHEMICAL
JOURNAL

www.elsevier.com/locate/microc

Development and critical comparison of greener flow procedures for nitrite determination in natural waters

Wanessa R. Melchert, Carlos M.C. Infante, Fábio R.P. Rocha*

Instituto de Química, Universidade de São Paulo, 05513-970, PO Box 26077, São Paulo, SP, Brazil

Received 17 May 2006; accepted 17 May 2006

Available online 3 July 2006

Determinação de nitrito



determinação de nitrito

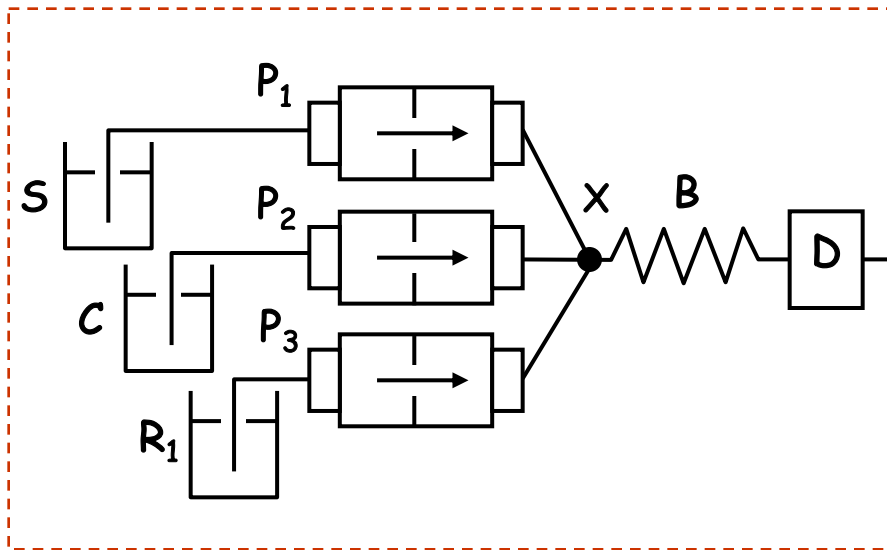

degradação do resíduo

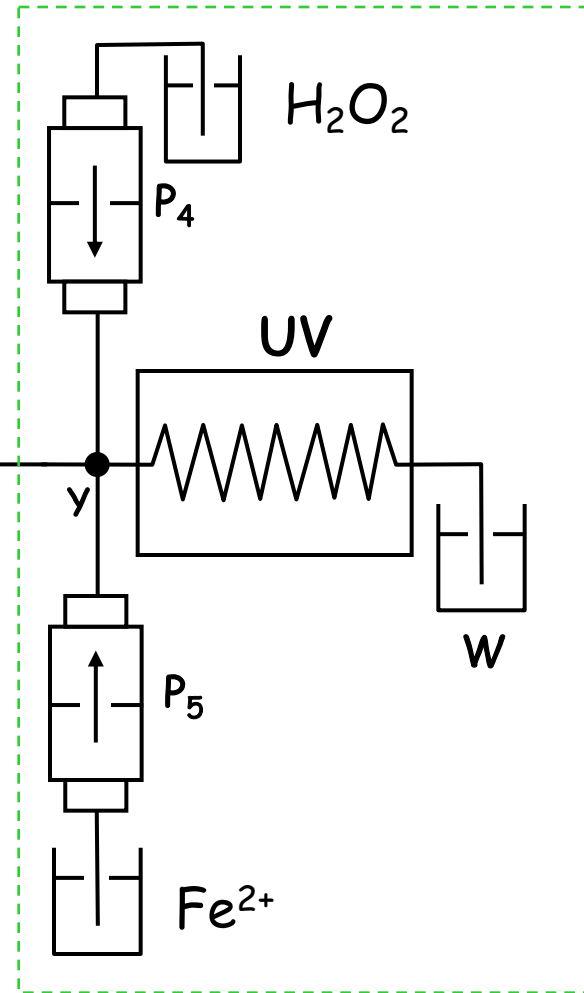

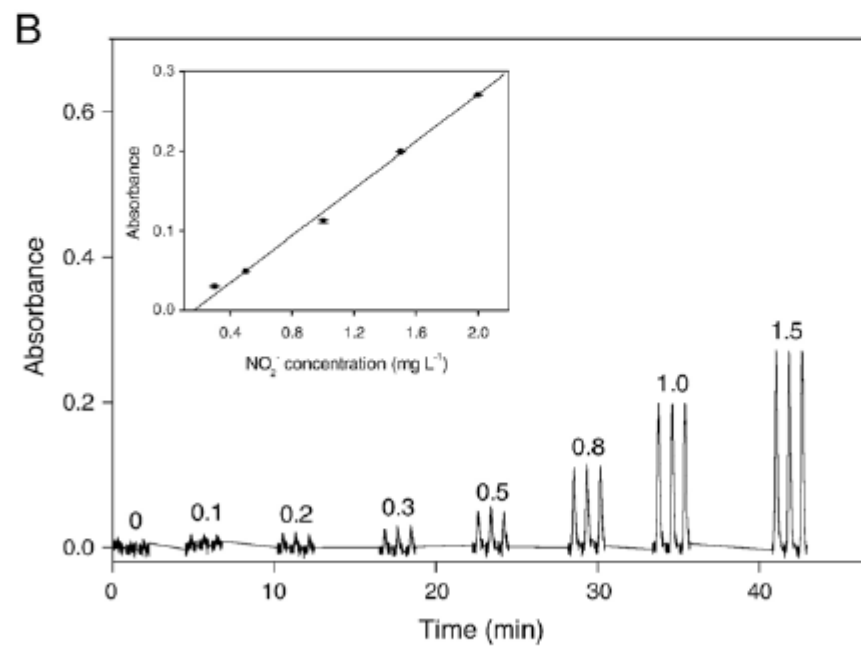
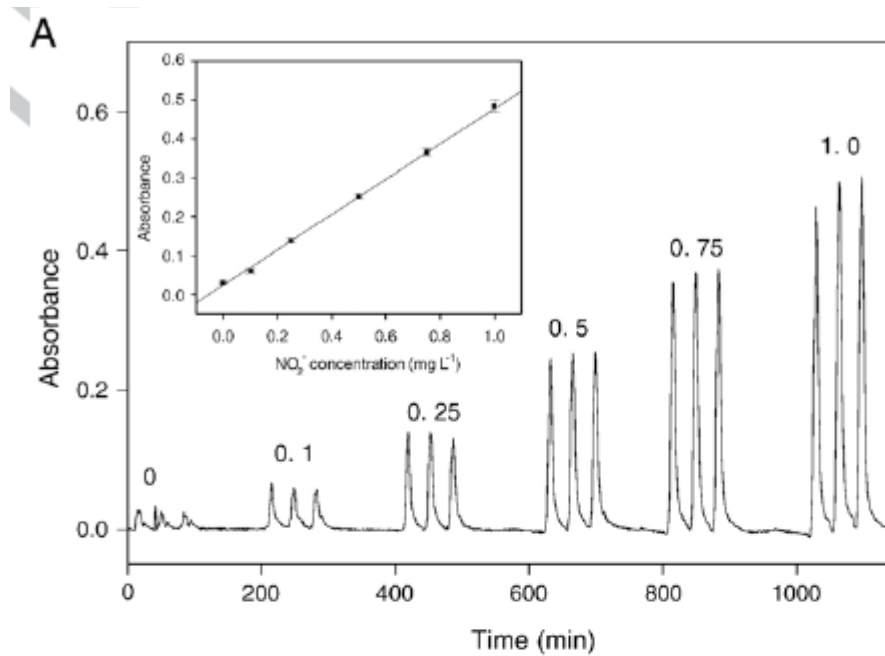

Consumo de reagentes e volume de efluentes

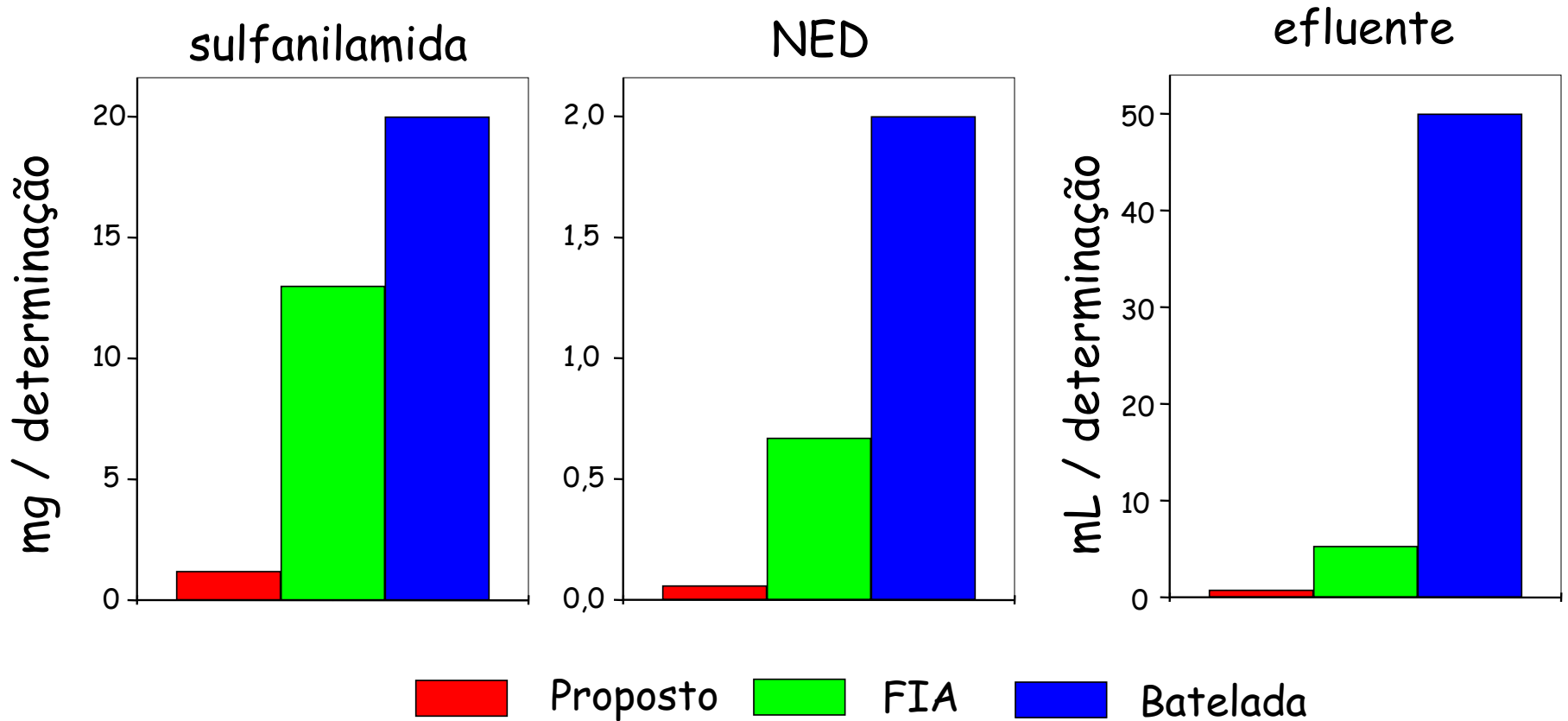

Determinação de nitrito



determinação de nitrito

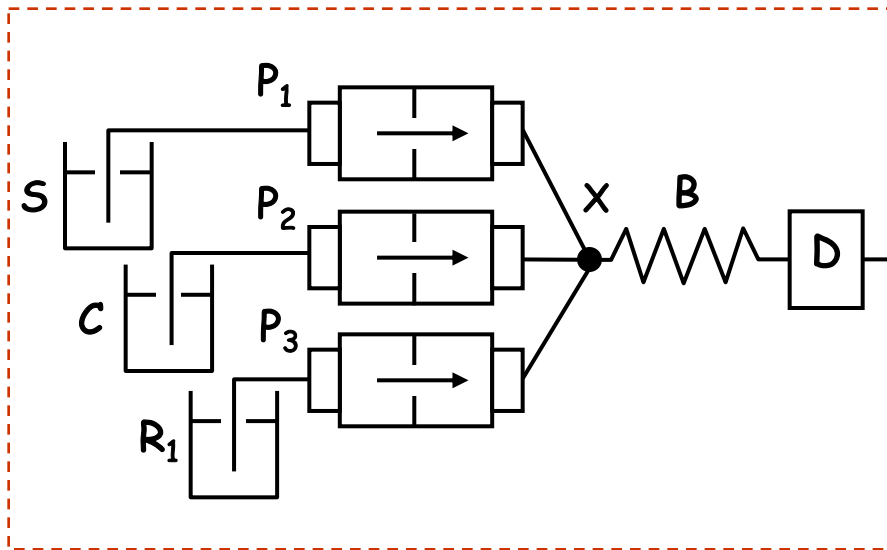

degradação do resíduo

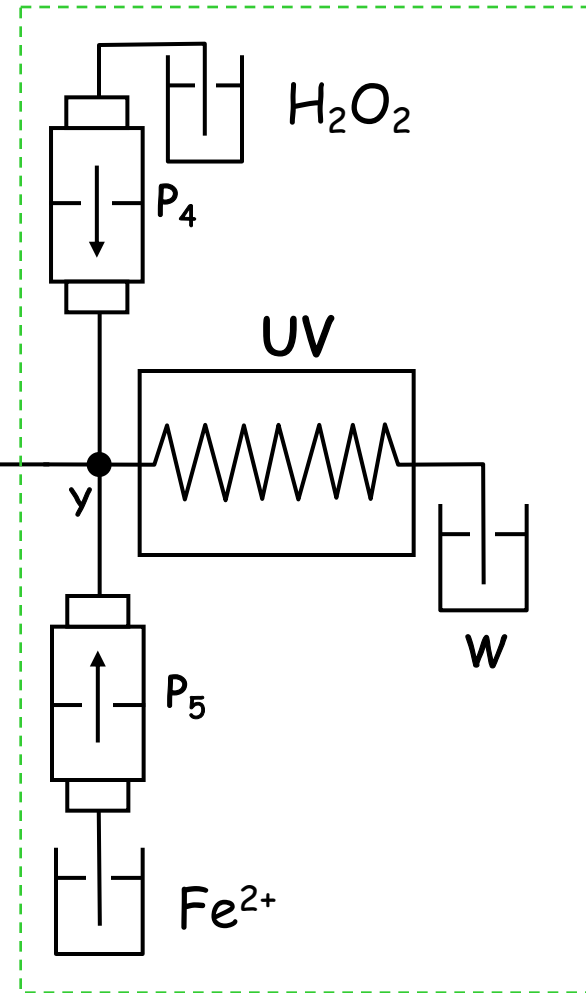

87% de mineralização

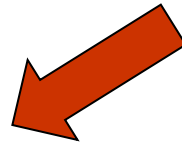

Medidas de carbono orgânico total (antes e após a foto-degradação)

Timeline showing the main contributions of **Brazilian** workers to flow analysis

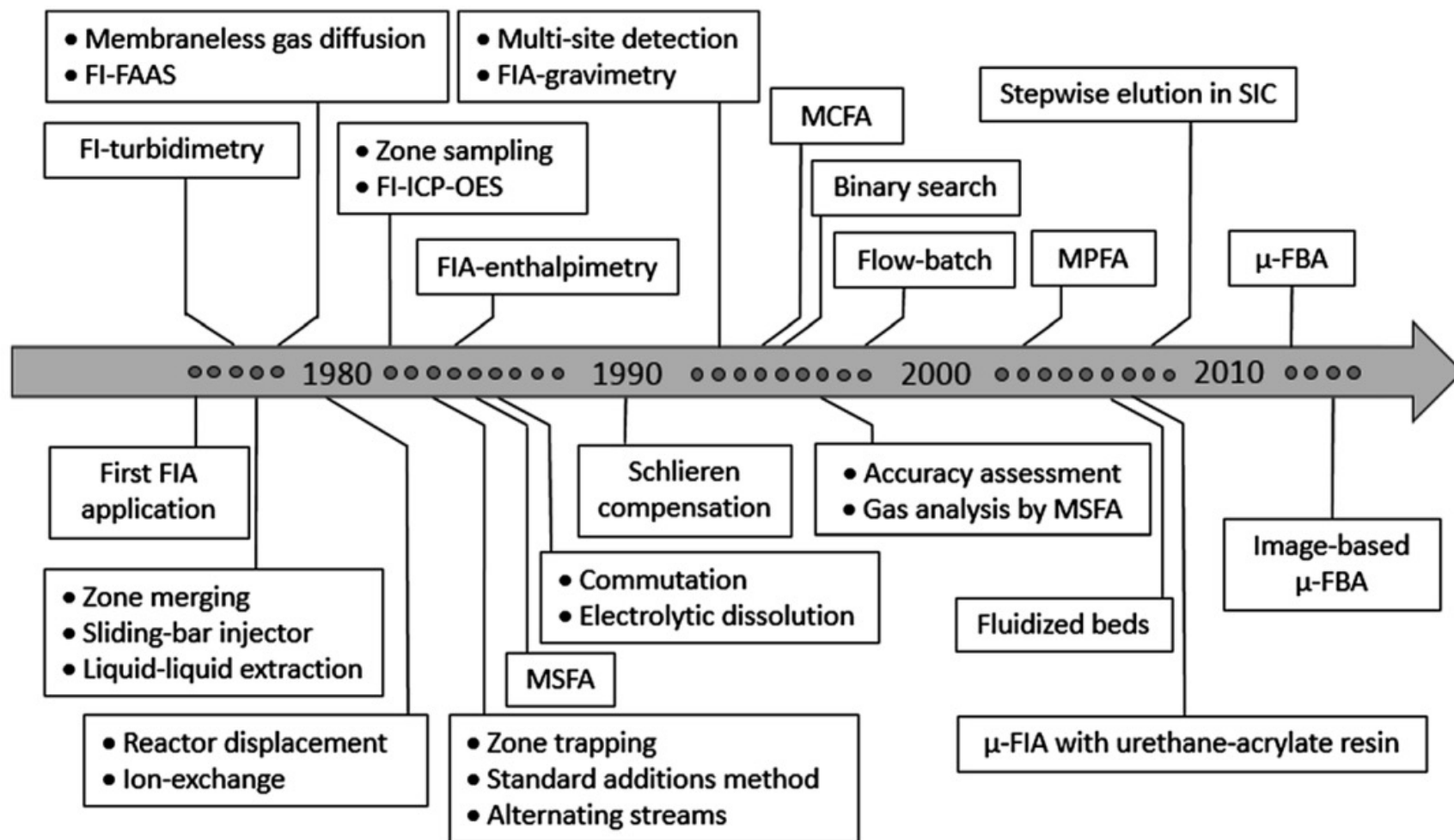

Sistemas comerciais

San++ Continuous Flow Analyzer

<https://www.youtube.com/watch?v=nvt-HlHfzng>

FIALab Instruments

<https://www.youtube.com/watch?v=wgzcjIhecUg>