

Disciplina

Química Medicinal

Prof. Dr. Andrei Leitão

Isomeria & isomeria constitucional

1. **Isômeros** são diferentes compostos com a mesma fórmula.
2. **Isômeros constitucionais** se diferem pela ordem de conexão dos átomos.

Fórmula Molecular	Número de isômeros constitucionais possíveis
C_4H_{10}	2
C_5H_{12}	3
C_6H_{14}	5
C_7H_{16}	9
C_8H_{18}	18
C_9H_{20}	35

Isomeria constitucional

<i>Fórmula Molecular</i>	<i>Isômeros Constitucionais</i>	
C_4H_{10}	$CH_3CH_2CH_2CH_3$ Butano	e $\begin{array}{c} CH_3 \\ \\ CH_3CHCH_3 \end{array}$ Isobutano
C_3H_7Cl	$CH_3CH_2CH_2Cl$ 1-Cloropropano	e $\begin{array}{c} CH_3CHCH_3 \\ \\ Cl \end{array}$ 2-Cloropropano
C_2H_6O	CH_3CH_2OH Etanol	e CH_3OCH_3 Éter dimetílico

Isomeria constitucional

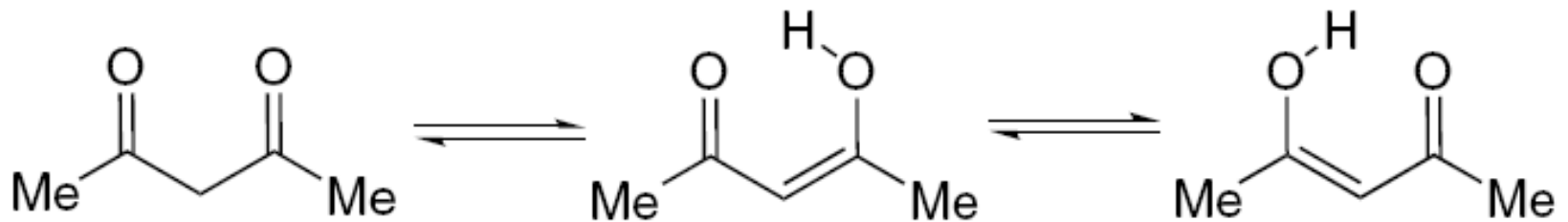
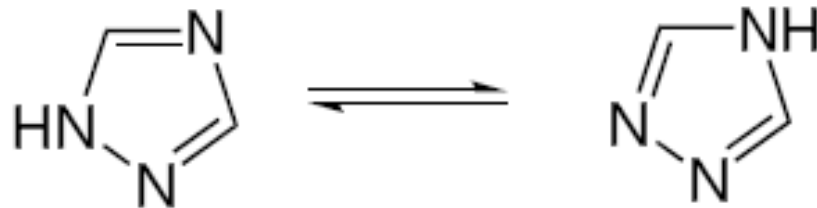

Estereoisômeros

Estereoisômeros se diferem apenas pelo arranjo dos átomos no espaço. Não são isômeros constitucionais.

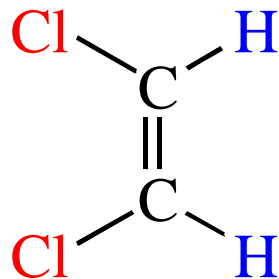

cis-1,2-Dichloroethene (C₂H₂Cl₂)
Z-1,2-Dichloroethene (C₂H₂Cl₂)

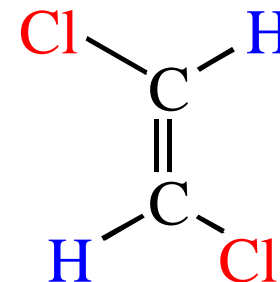

trans-1,2-Dichloroethene (C₂H₂Cl₂)
E-1,2-Dichloroethene (C₂H₂Cl₂)

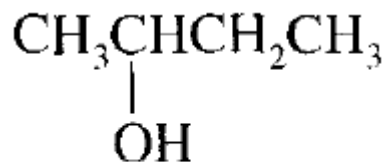

2-Butanol

Esteroisômeros (2)

Enantiômeros são imagens especulares não superponíveis.

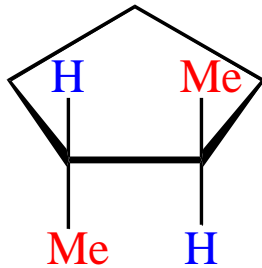

trans-1,2-Dimethylcyclopentane (C₇H₁₄)

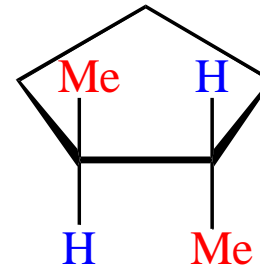

trans-1,2-Dimethylcyclopentane (C₇H₁₄)

Diastereômeros não são imagens especulares.

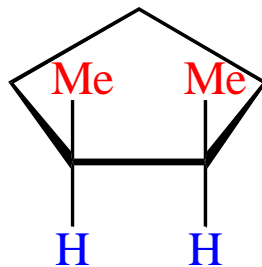

cis-1,2-Dimethylcyclopentane
(C₇H₁₄)

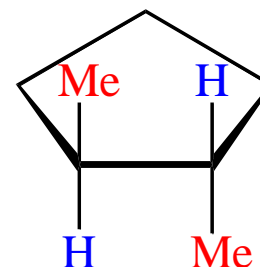

trans-1,2-Dimethylcyclopentane
(C₇H₁₄)

Estereoisômeros - enantiômeros

Estereoisômeros se diferem apenas pelo arranjo dos átomos no espaço. Não são isômeros constitucionais.

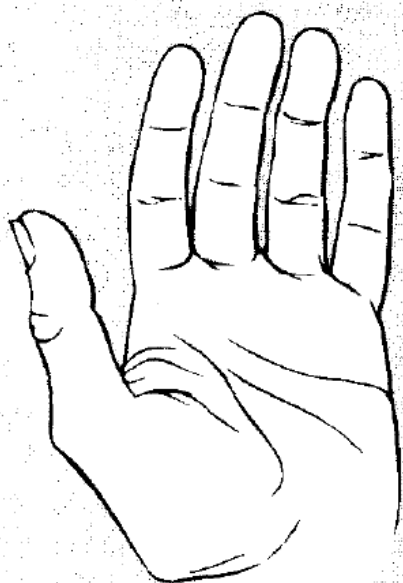

Mão esquerda



Espelho

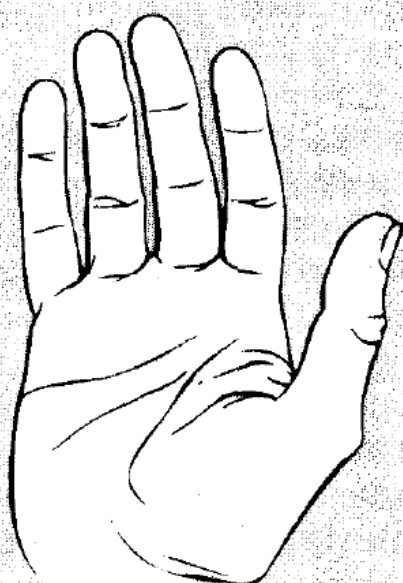

Mão direita

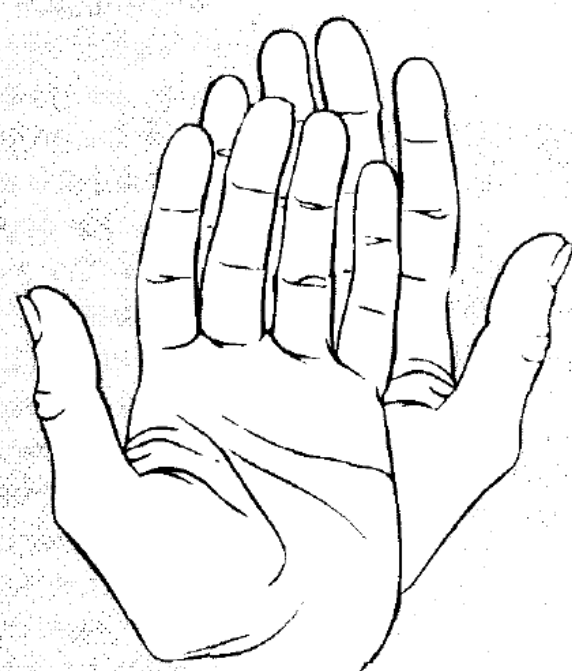

Estereoisomeria - Enantiômero

- ✓ Enantiômeros são distinguidos pela luz plano-polarizada e são a imagem especular um do outro (não se superpõem):

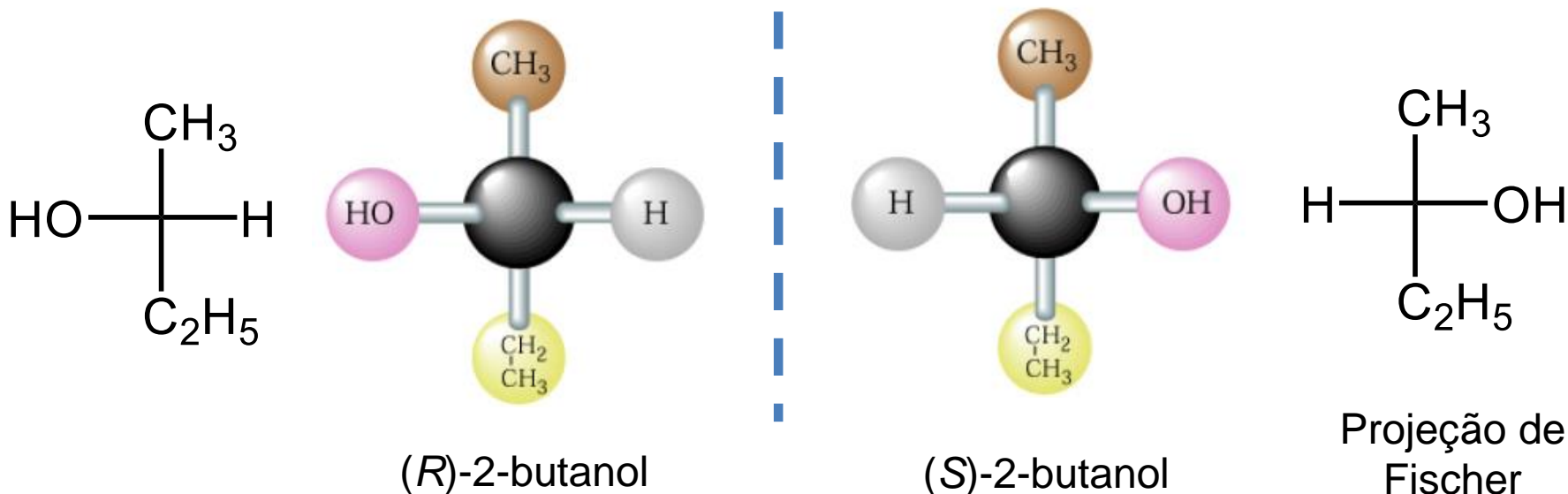

- ✓ O carbono assimétrico é um centro quiral

Regra de Cahn-Ingold-Prelog

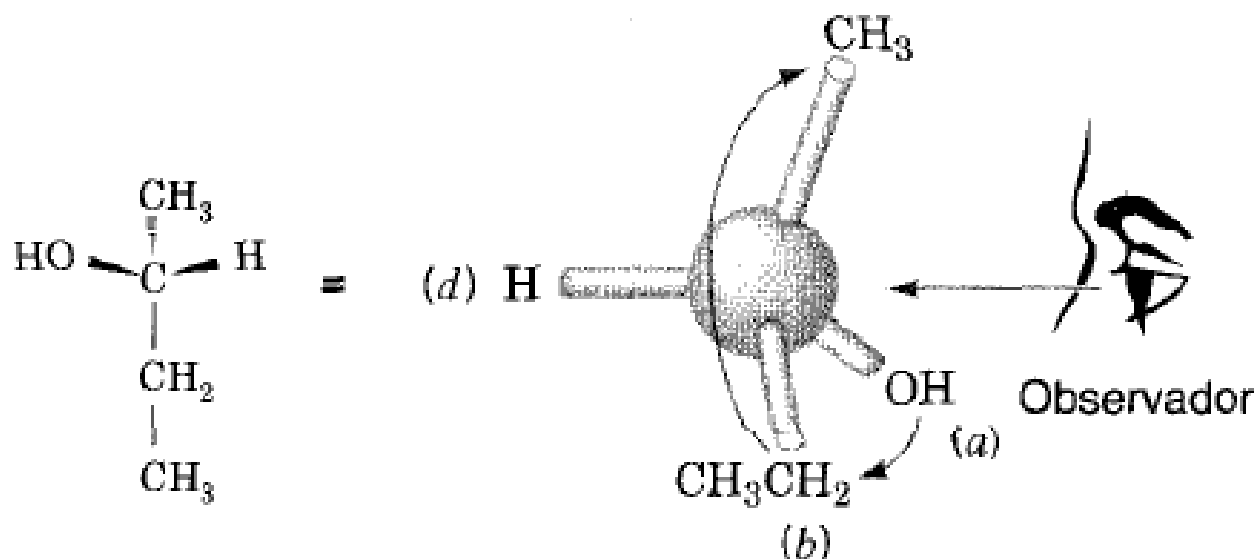

As setas estão no sentido horário

Tabela 5.1 Propriedades Físicas de (R)- e (S)-2-Butanol

Propriedade Física	(R)-2-Butano	(S)-2-Butanol
Ponto de ebulição (1 atm)	99,5°C	99,5°C
Densidade (g mL ⁻¹ a 20°C)	0,808	0,808
Índice de refração (20°C)	1,397	1,397

Desvio da luz plano-polarizada

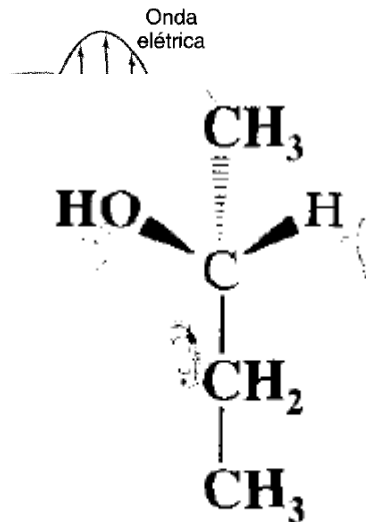
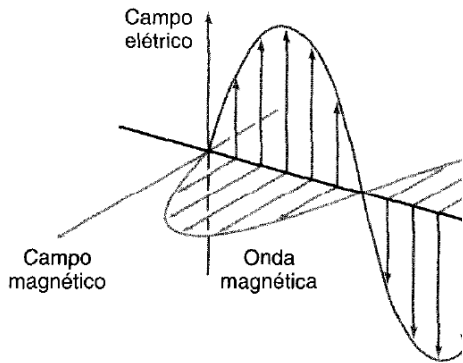

(R)-2-Butanol
 $[\alpha]_D^{25} = -13,52^\circ$

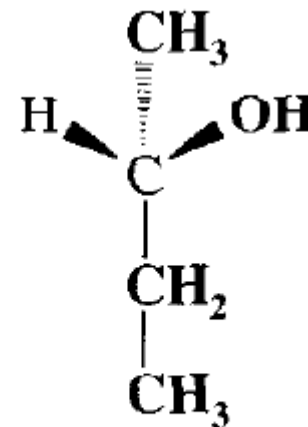

(S)-2-Butanol
 $[\alpha]_D^{25} = +13,52^\circ$

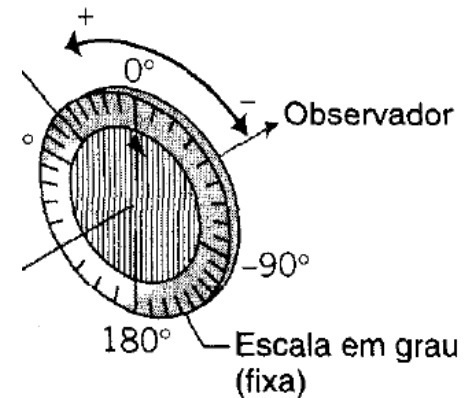

O plano de polarização da luz emergente não é o mesmo da luz polarizada de entrada.

Polarizador

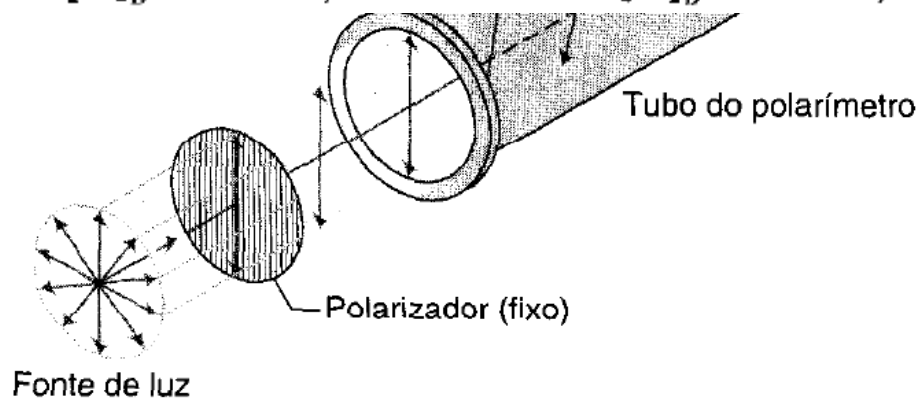

Estereoisomeria - Diastereômero

- ✓ Diastereômeros não são imagem especular um do outro:

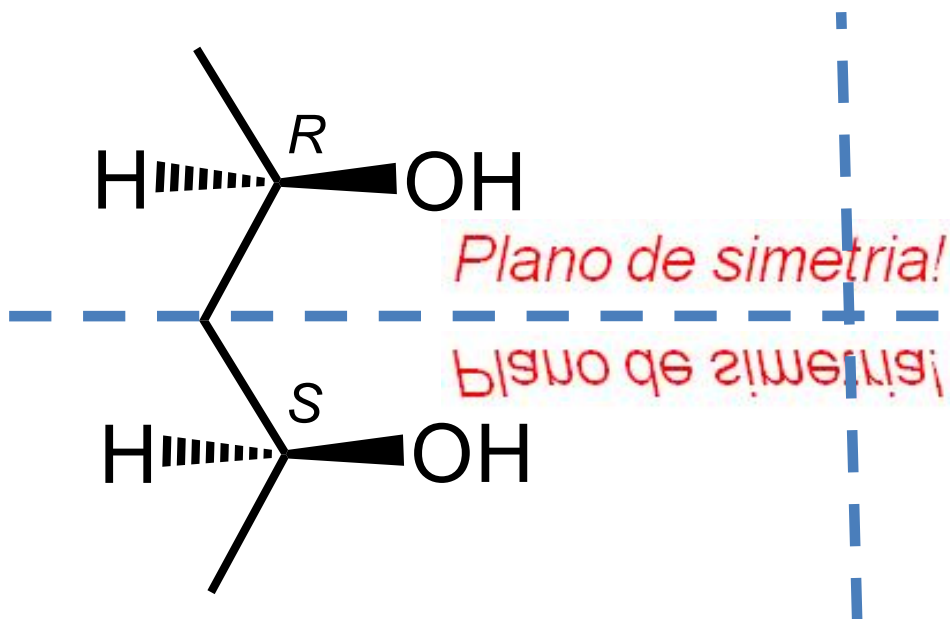

(2R,4S)-pentano-2,4-diol

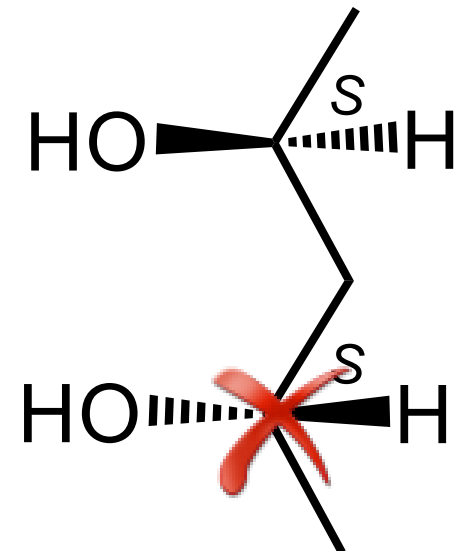

(2S,4S)-pentano-2,4-diol

Isomeria

Substituente	Isômero	PF (°C)	PE (°C)
1,2-Dimethyl-	<i>Z ou cis</i>	-50,1	130,04
1,2-Dimethyl-	<i>E ou trans</i>	-89,4	123,7
1,3-Dimethyl-	<i>Z ou cis</i>	-75,6	120,1
1,3-Dimethyl-	<i>E ou trans</i>	-83,5	123,5

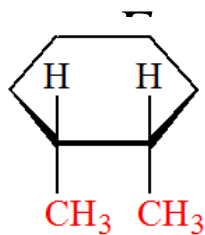

cis-1,2-dimetilcicloexano

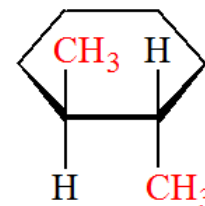

trans-1,2-dimetilcicloexano

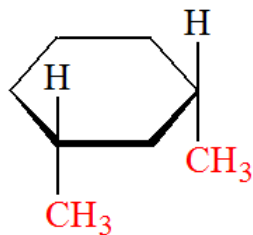

cis-1,3-dimetilcicloexano

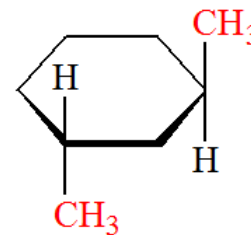

trans-1,3-dimetilcicloexano

Isomeria

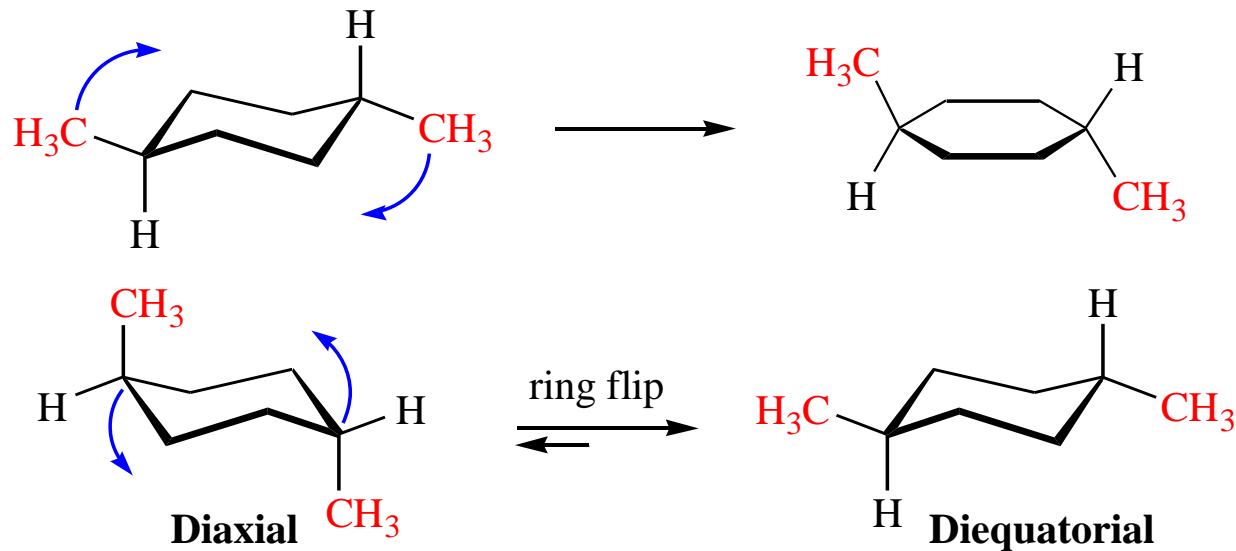

- 1) **Diaxial** e **diequatorial** *trans*-1,4-dimetilcicloexano.
- 2) A conformação **diequatorial** é a **mais estável** e representa pelo menos 99% das moléculas no equilíbrio.

Isomeria

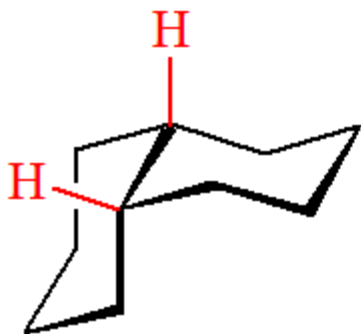
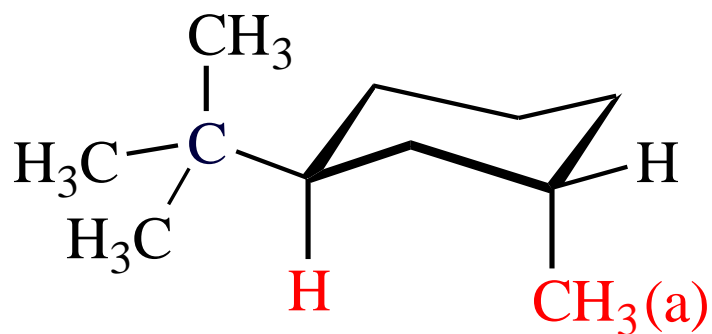

cis-Decalina

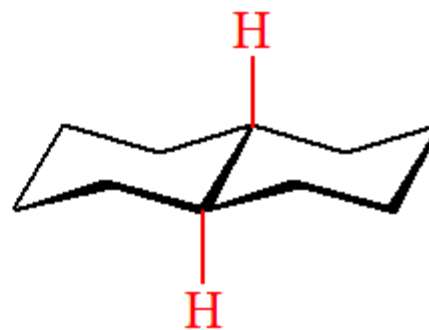

trans-Decalina

A *cis-Decalina* ferve a 195°C e a *trans-decalina* ferve a 185.5°C

Síntese de racemato

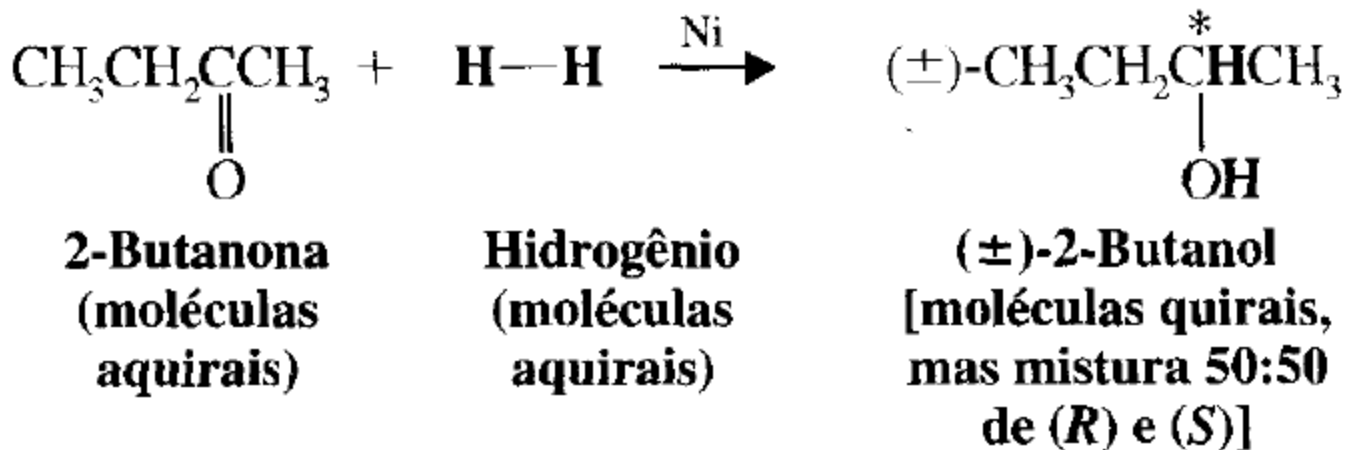

Síntese enantiosseletiva

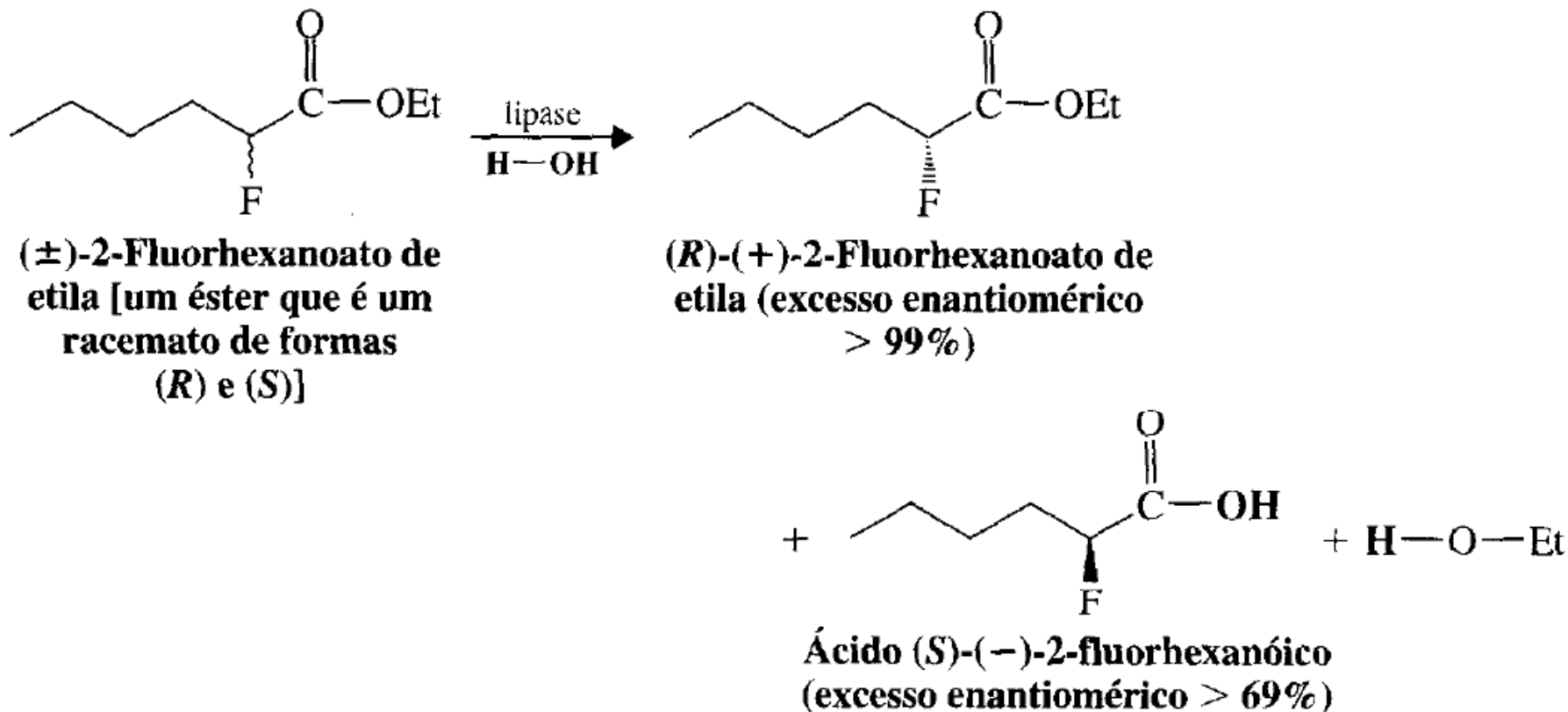

Síntese de racemato

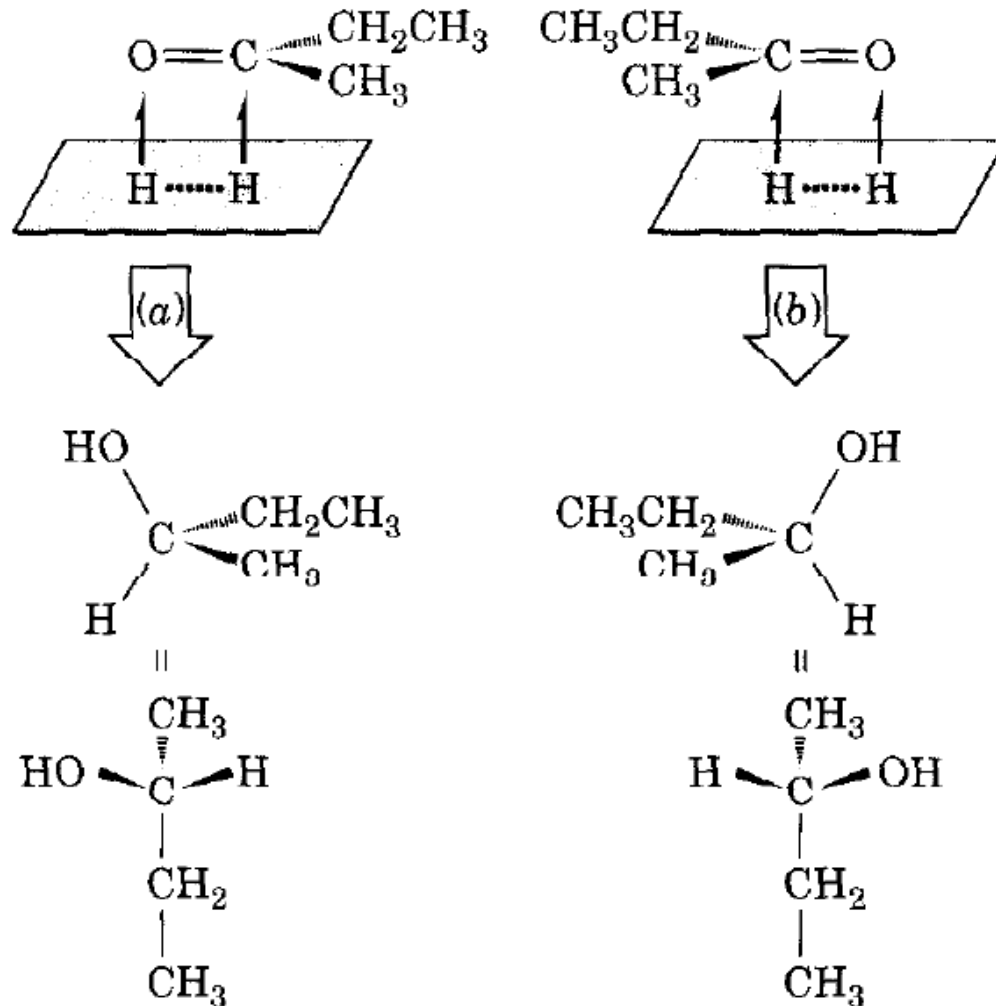

(R)-(-)-(2)-Butanol

(S)-(+)-(2)-Butanol

Síntese enantiosseletiva

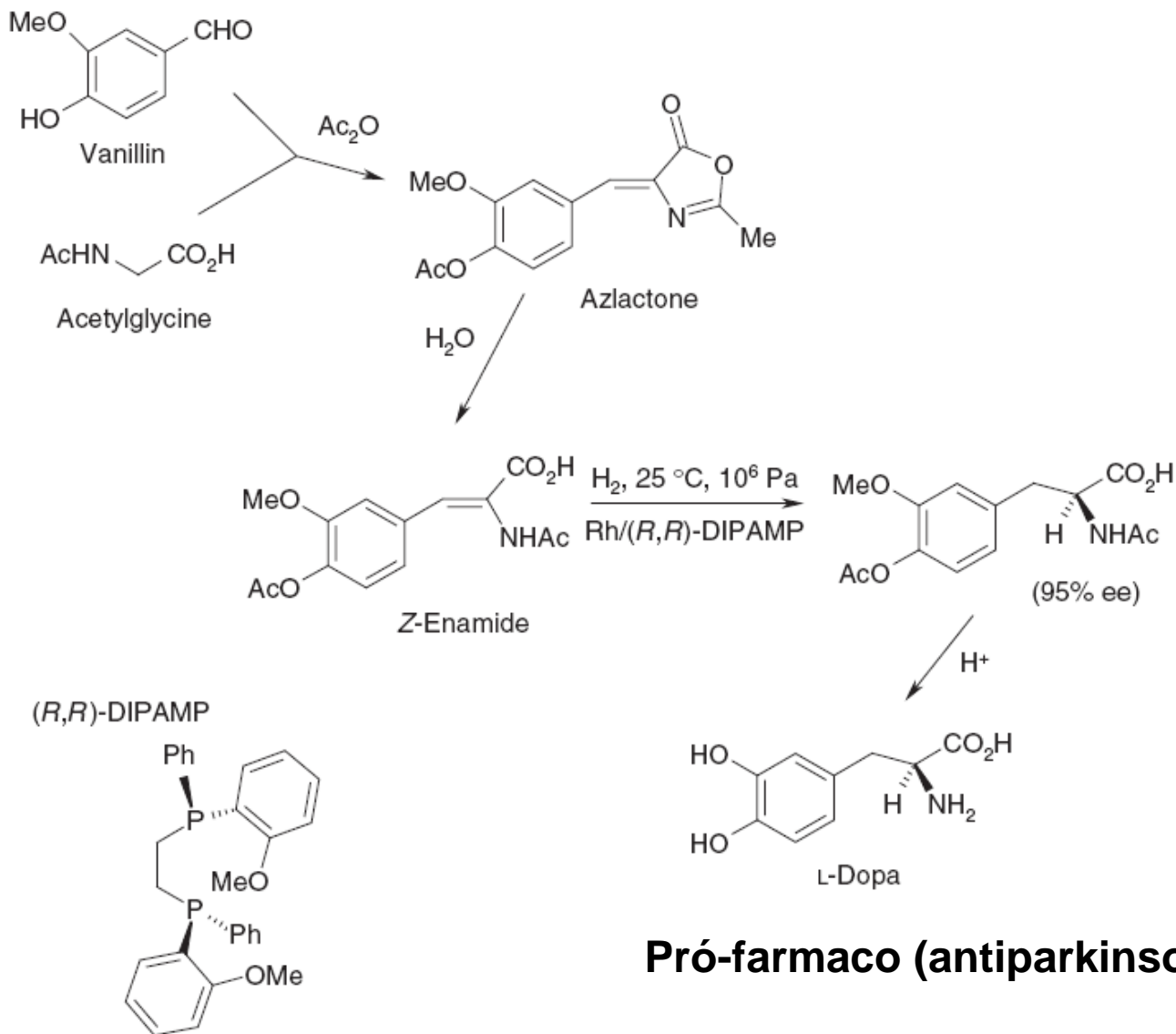

Preservação do centro estereogênico

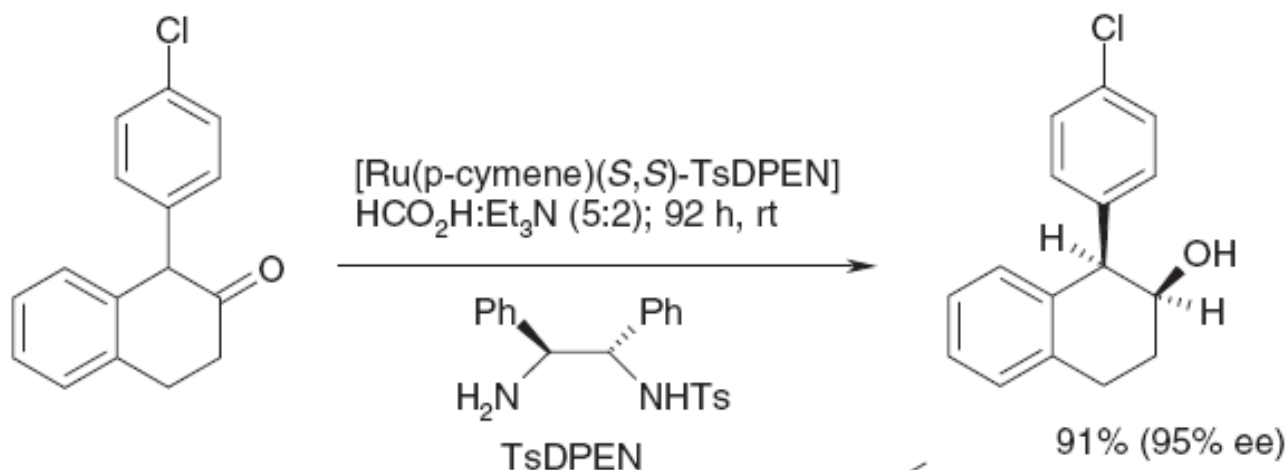

Benzazepina
(antagonista D1)

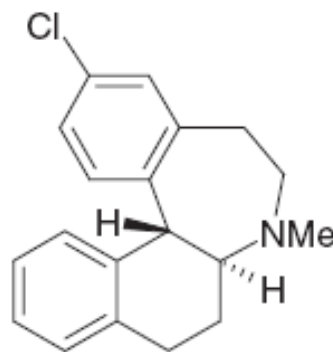

Processo enantiosseletivo para herbicida

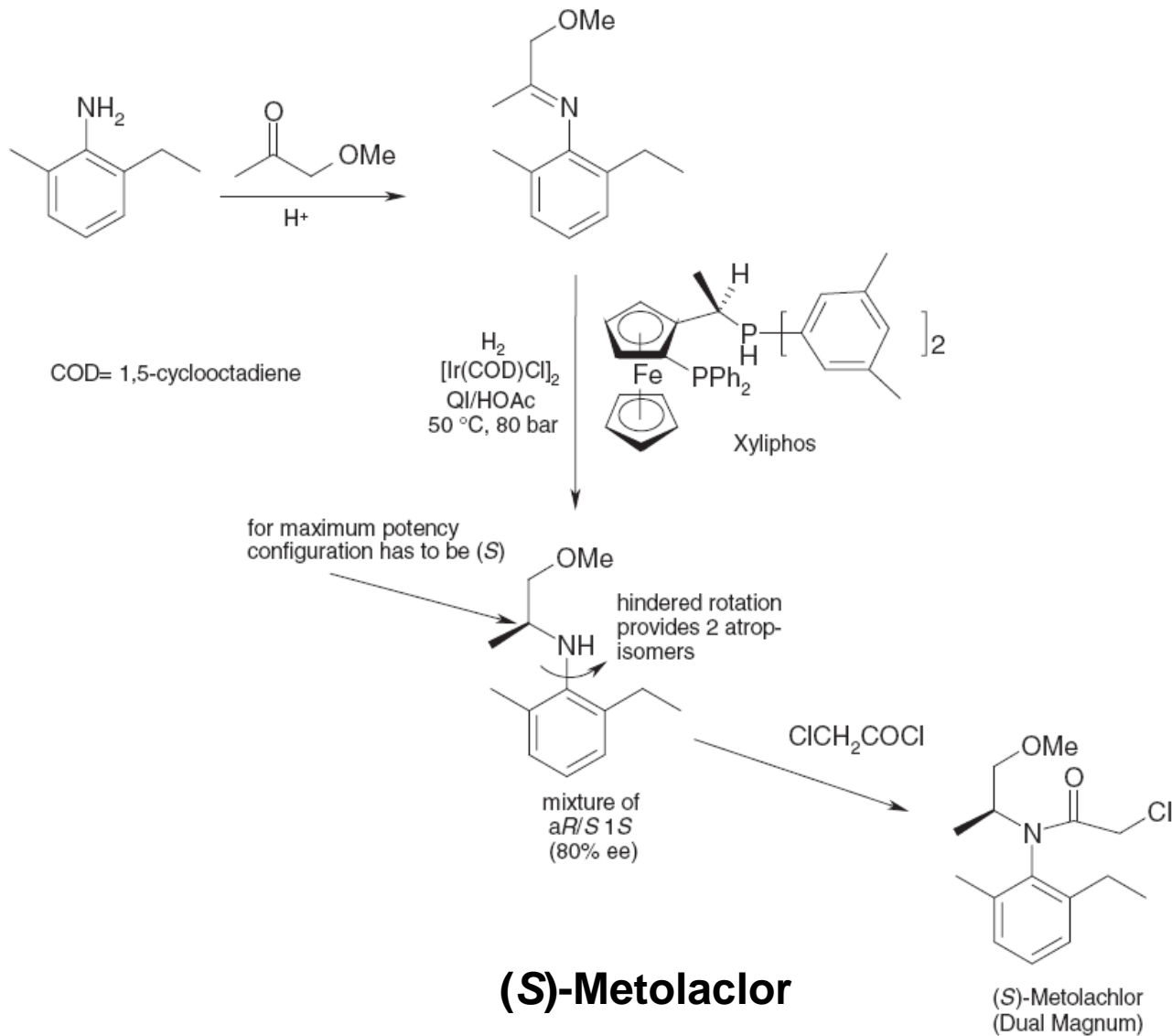

Reação em meio básico

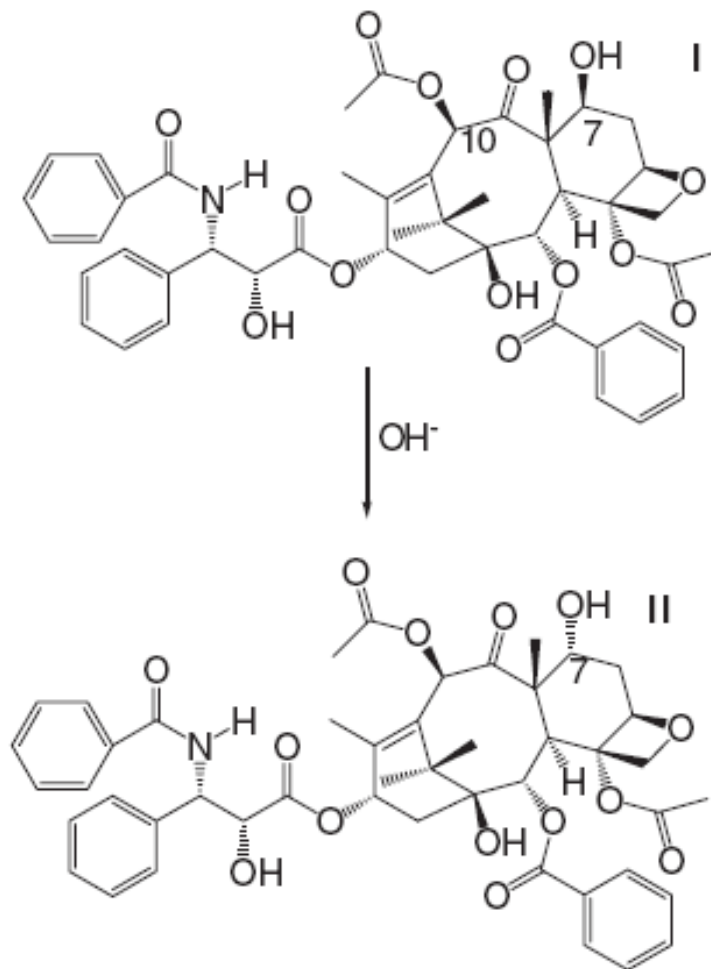

taxol