

Montagem Eletrônica

“PACKAGING”

O propósito do “Packaging” em Eletrônica é

- Fornecer suporte mecânico,
- Inter-conexão elétrica,
- Gerenciamento de calor
- Proteção aos Circuitos em relação a fontes de interferência mecânicas e ambientais.

EMCAPSULAMENTO ELETRÔNICO (PACKAGING)

- Define-se como a Tecnologia de Interconexão de Componentes Eletrônicos. Esta tecnologia permite definir e controlar o ambiente operacional dos arranjos com o objetivo de cumprir especificações em termos de:
 1. Desempenho
 2. Confiabilidade
 3. Velocidade
 4. Tamanho
 5. Custo
 6. Outros

HIERARQUIA DO ENCAPSULAMENTO ELETRÔNICO

- Nível 0
 - “Dies” (Circuitos integrados)
- Nível 1
 - A nível de “CHIP”
- Nível 2
 - A nível de Circuito impresso
- Nível 3
 - A nível de arranjo de C. Impresso
- Nível 4
 - A nível de Sistema

HIERARQUIA NO ENCAPSULAMENTO ELETRÔNICO

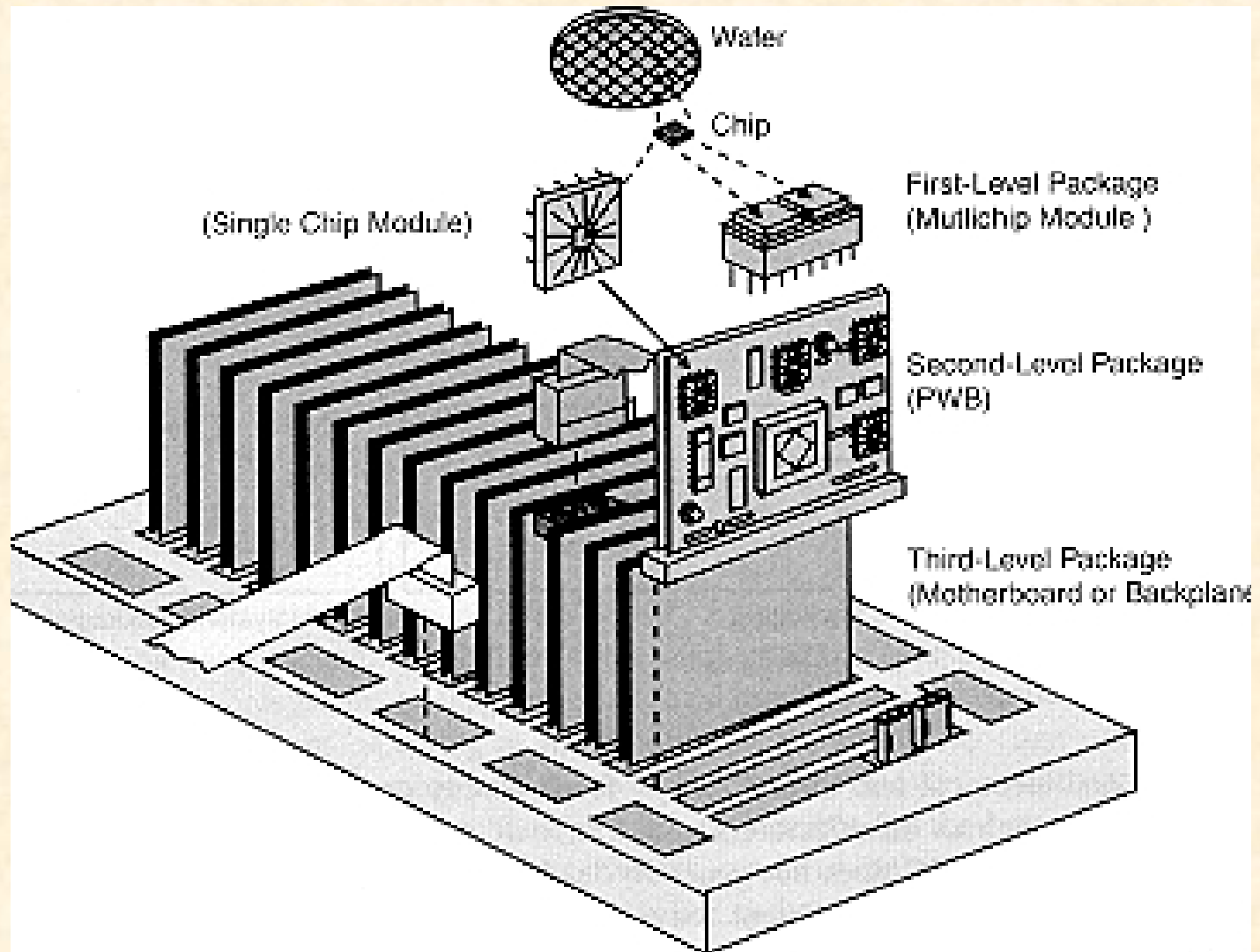

HI ERARQUI A PARA “ PACKAGI NG”

- Propõe-se uma hierarquia para sistemas assim:
- Nível do “Componente”
 - Envolve passivação, isolamento, colagem e interconexão elétrica “Wire Bonding” dos diversos sensores e atuadores do sistema
- Nível do Dispositivo
 - Envolve fornecimento de energia , transdução de sinais (entrada/ saída) e interconexões elétricas e colagem dos diversos componentes
- Nível do Sistema
 - Envolve quatro tarefas importantes de engenharia:
 - Projeto do circuito
 - Fabricação do circuito
 - Montagem do sistema
 - Inspeção e Testes do sistema

ENCAPSULAMENTOS TÍPICOS

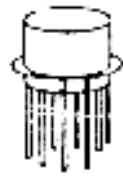

Transistor outline can

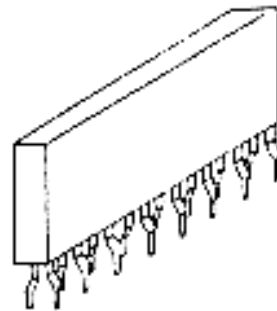

Single in-line package

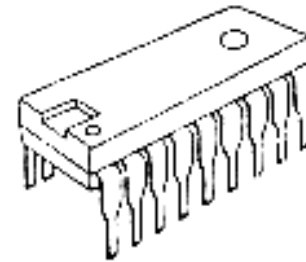

Plastic dual in-line package



Small-outline IC

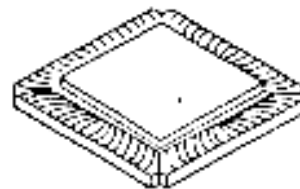

Ceramic leadless chip carrier

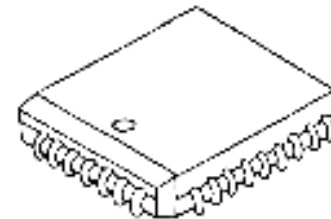

Plastic leaded chip carrier



Metal flatpack

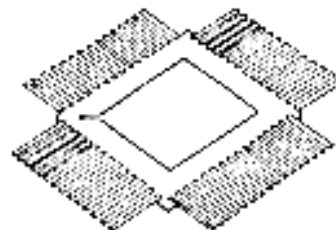

Ceramic flatpack

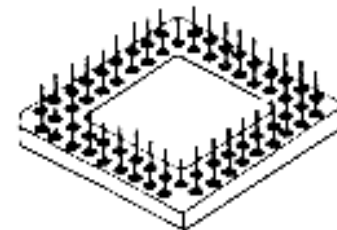

Ceramic pin grid array

Assortment of level 1 IC packages

ENCAPSULAMENTO A NÍVEL DE CHIP

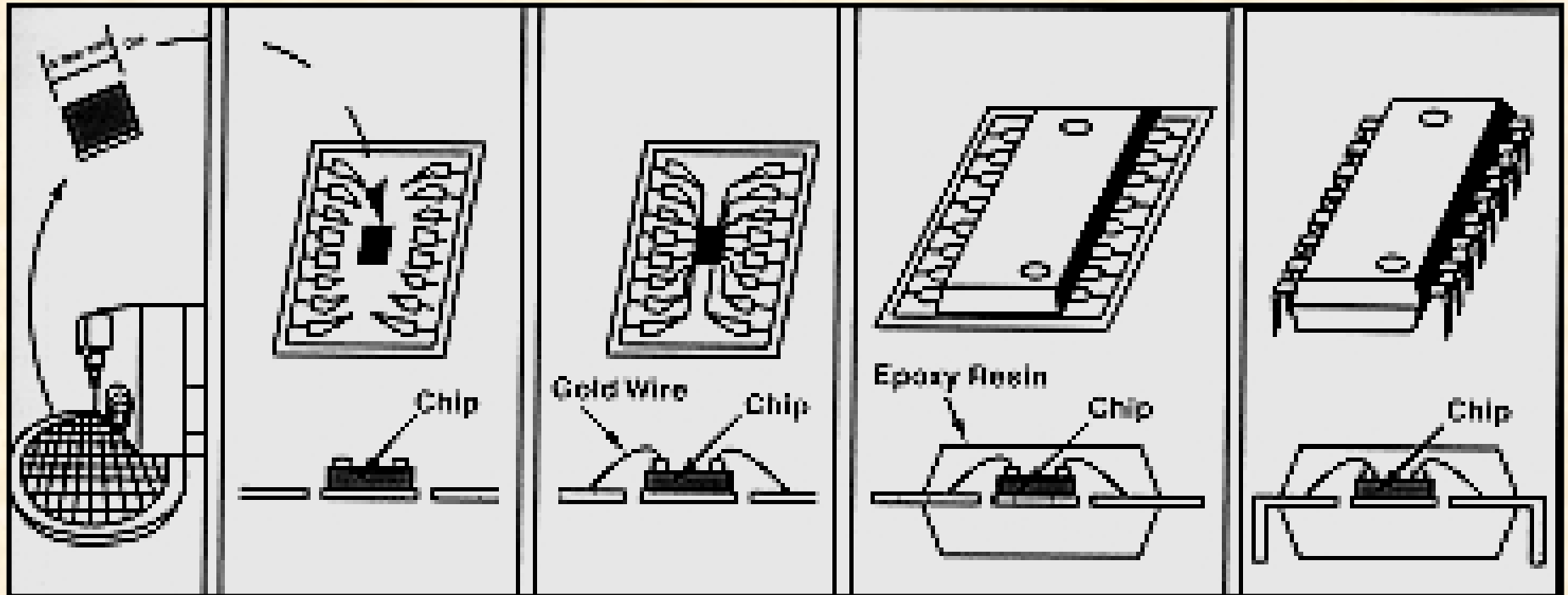

TÉCNI CAS DE ENCAPSULAMENTO 2D (PLÁSTI COS)

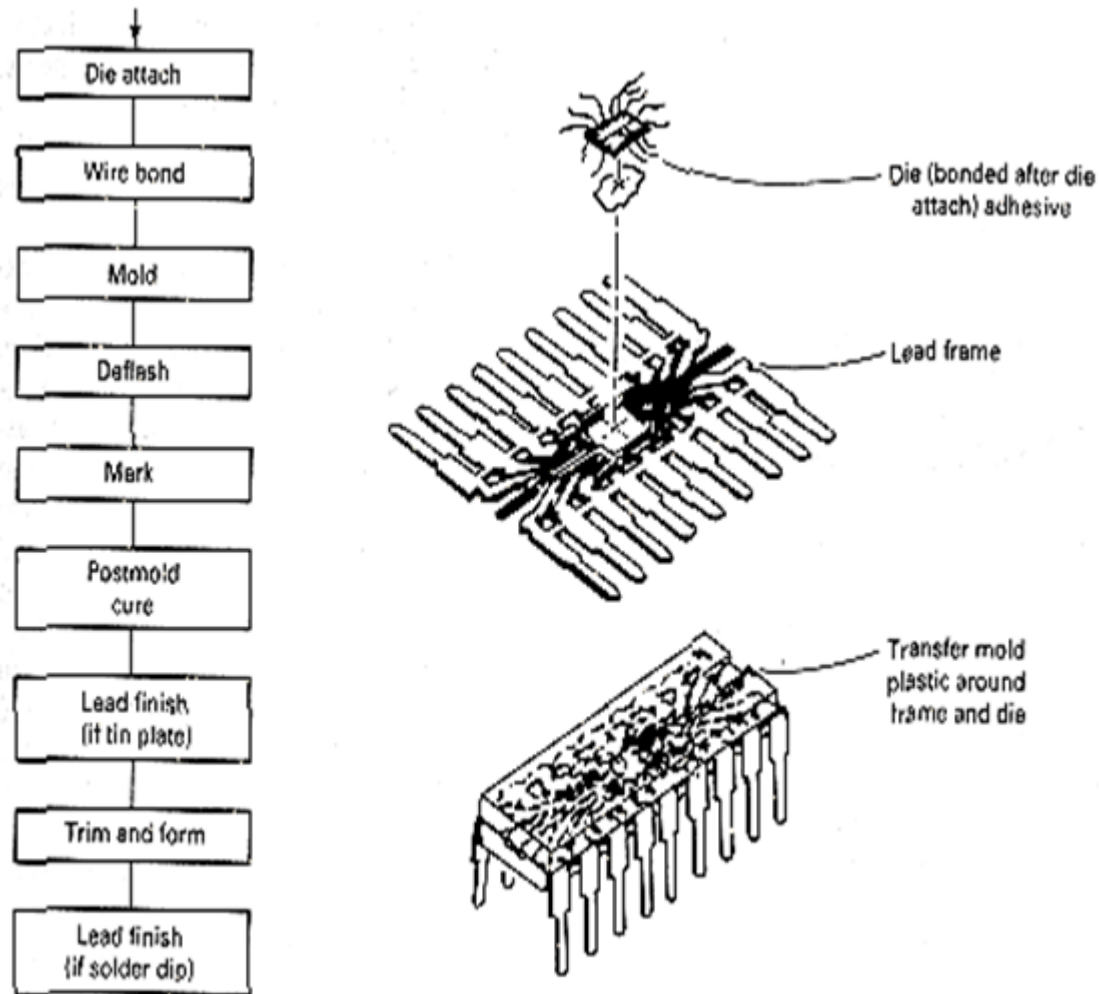

Fig. 7 Assembly sequence for plastic postmolded dual-in-line package. The lead frame serves as the chip carrier after die bond and wire bond.

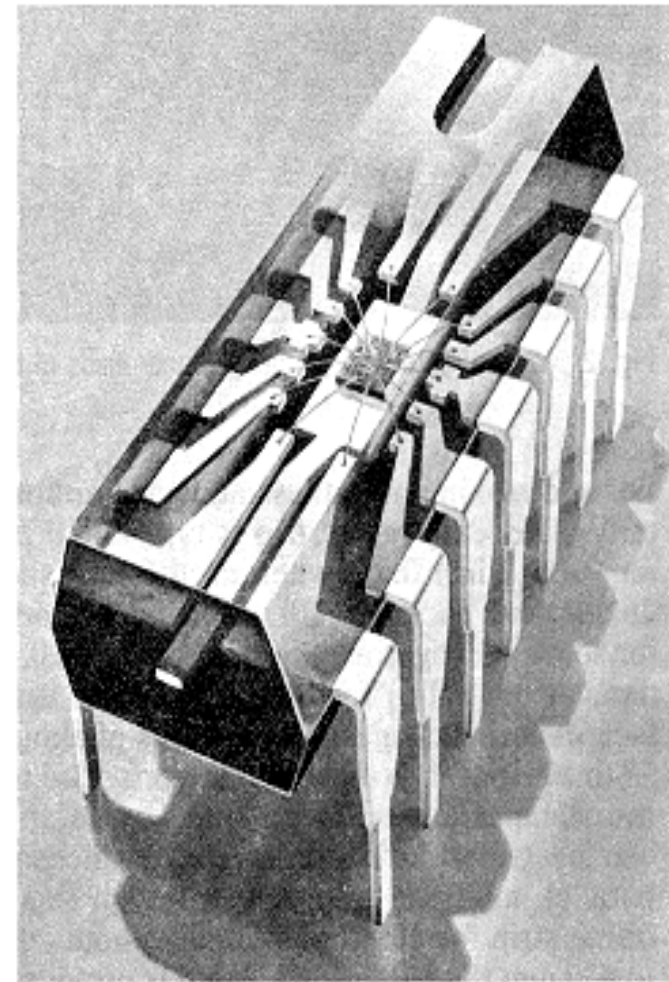

Fig. 1 View of lead frame positioning in postmolded nonhermetic package showing wire interconnects from chip to inner leads of lead frame

TÉCNICAS DE ENCAPSULAMENTO 2D (Cerâmicos)

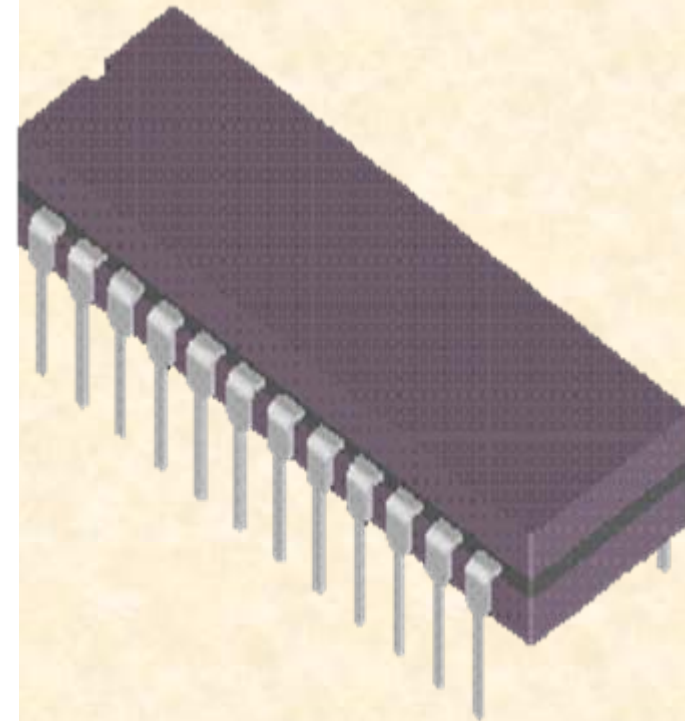
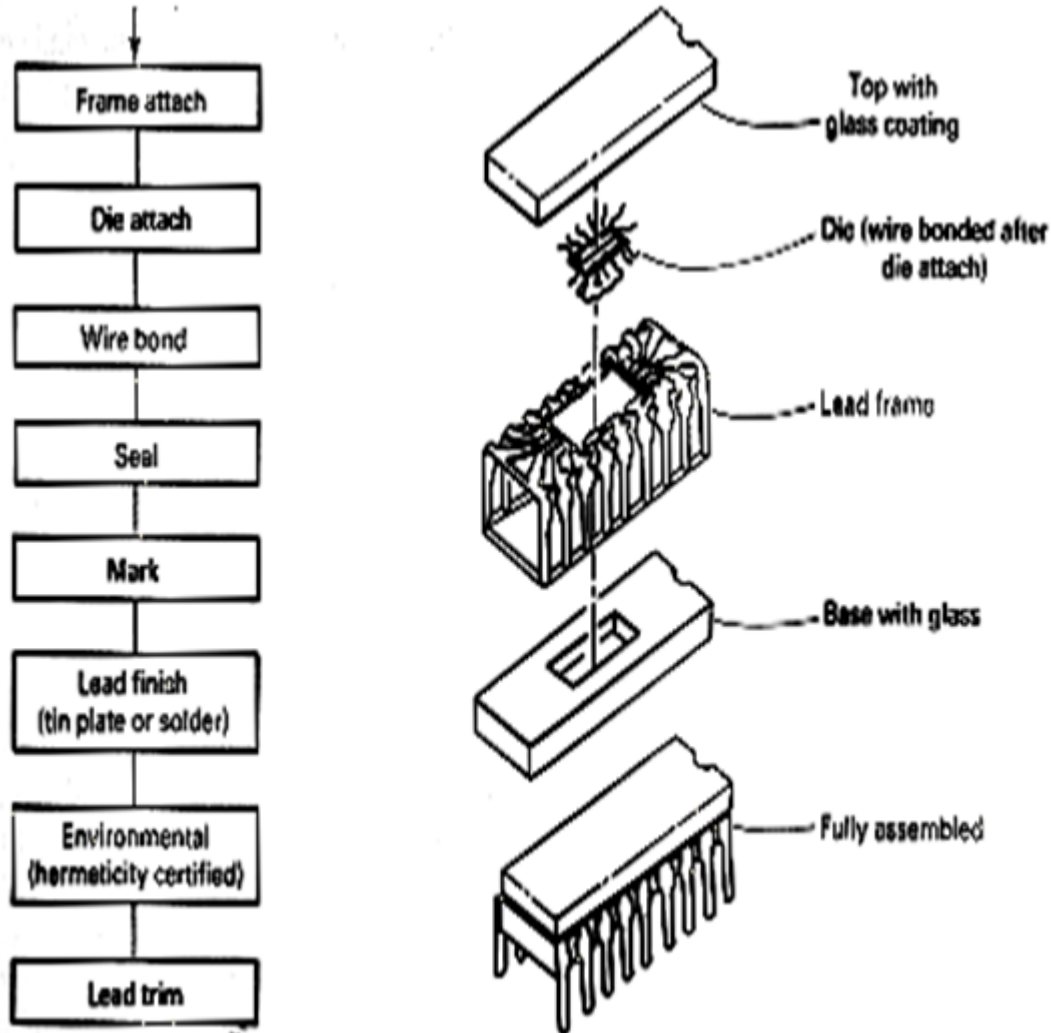
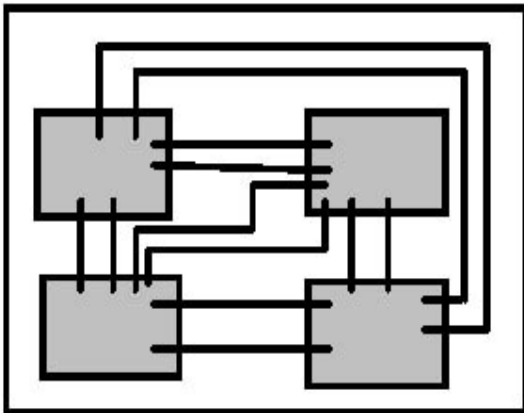

Fig. 6 Assembly sequence for ceramic dual-in-line packages. Base and top components come already glaze coated with glass for lead frame sink and seal.

DE "2D" PARA "3D"

- Vantagens do encapsulamento 3D
 - Área e peso do encapsulamento
 - Interconexões em 3D
 - Menores retardo e maior largura de banda
 - Menor ruído e consumo de potência
 - Maior acessabilidade para interconexões verticais

2D chip packaging
2D interconnection



2D chip packaging
3D interconnection

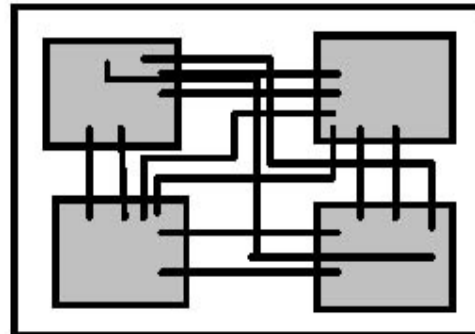

3D chip packaging



TÉCNICAS DE ENCAPSULAMENTO 3D

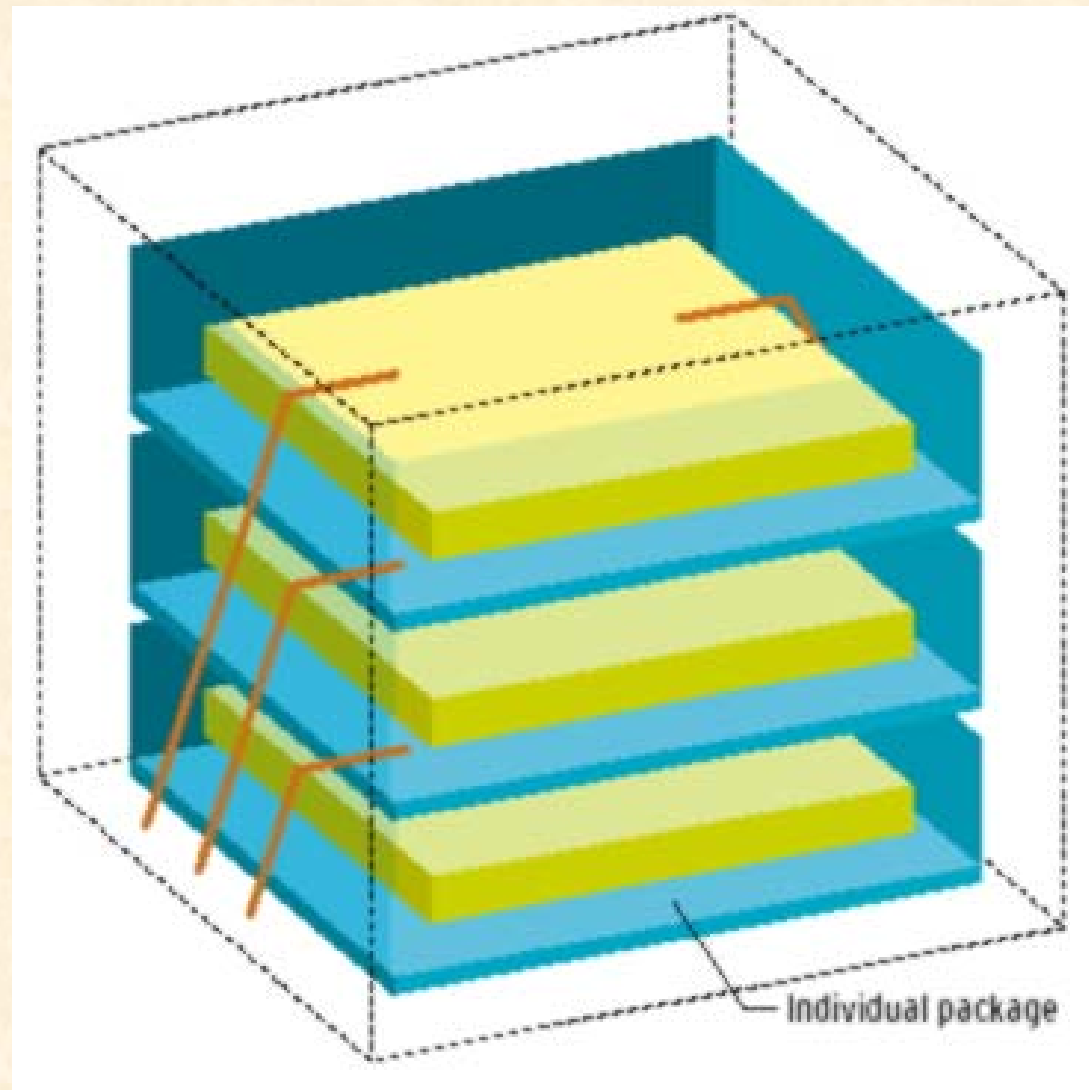

NOVO CONCEITO: MICRO-SISTEMAS MODULARES

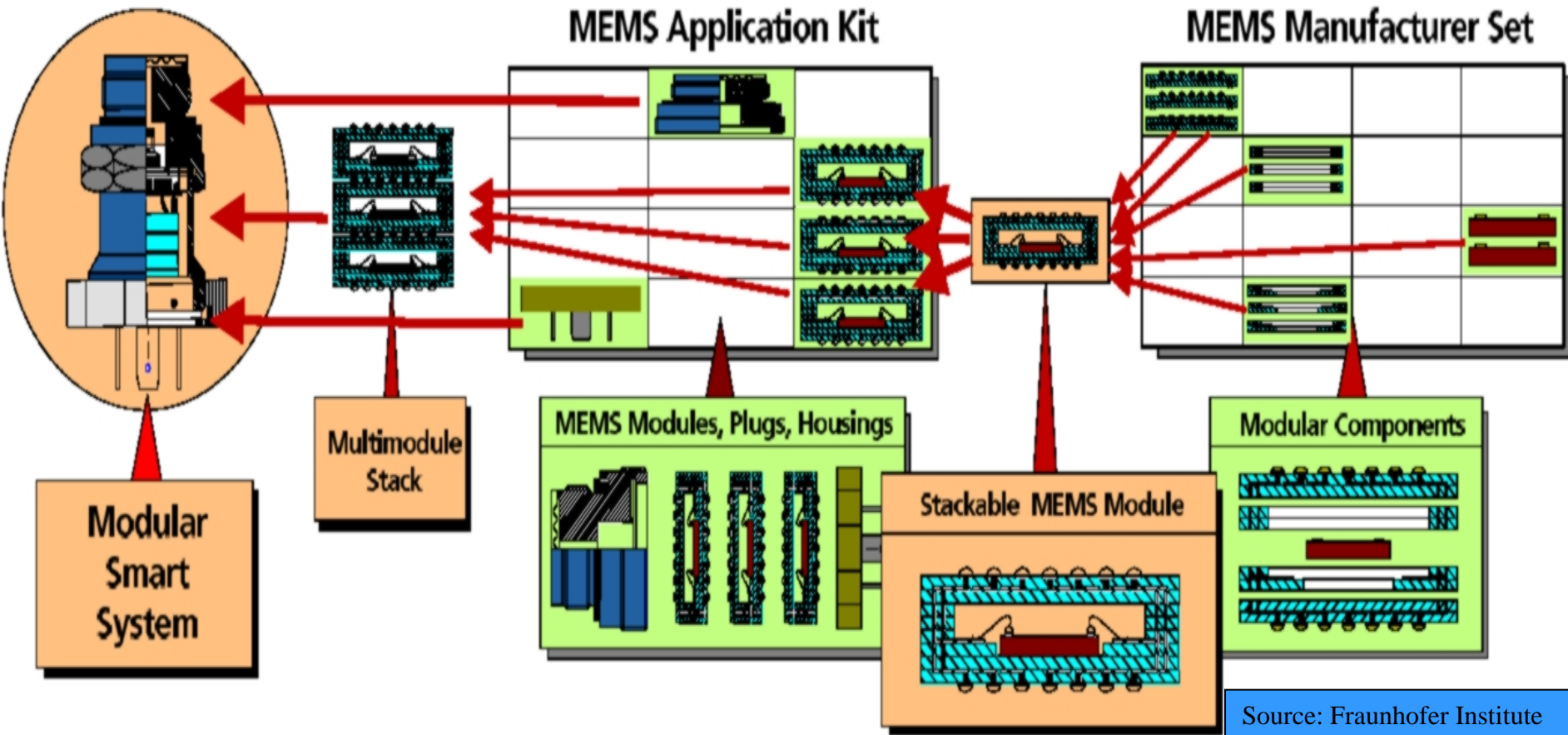

APLI CAÇÕES DO CONCEITO MODULAR (SMART PRESSURE CONTROL SYSTEM)

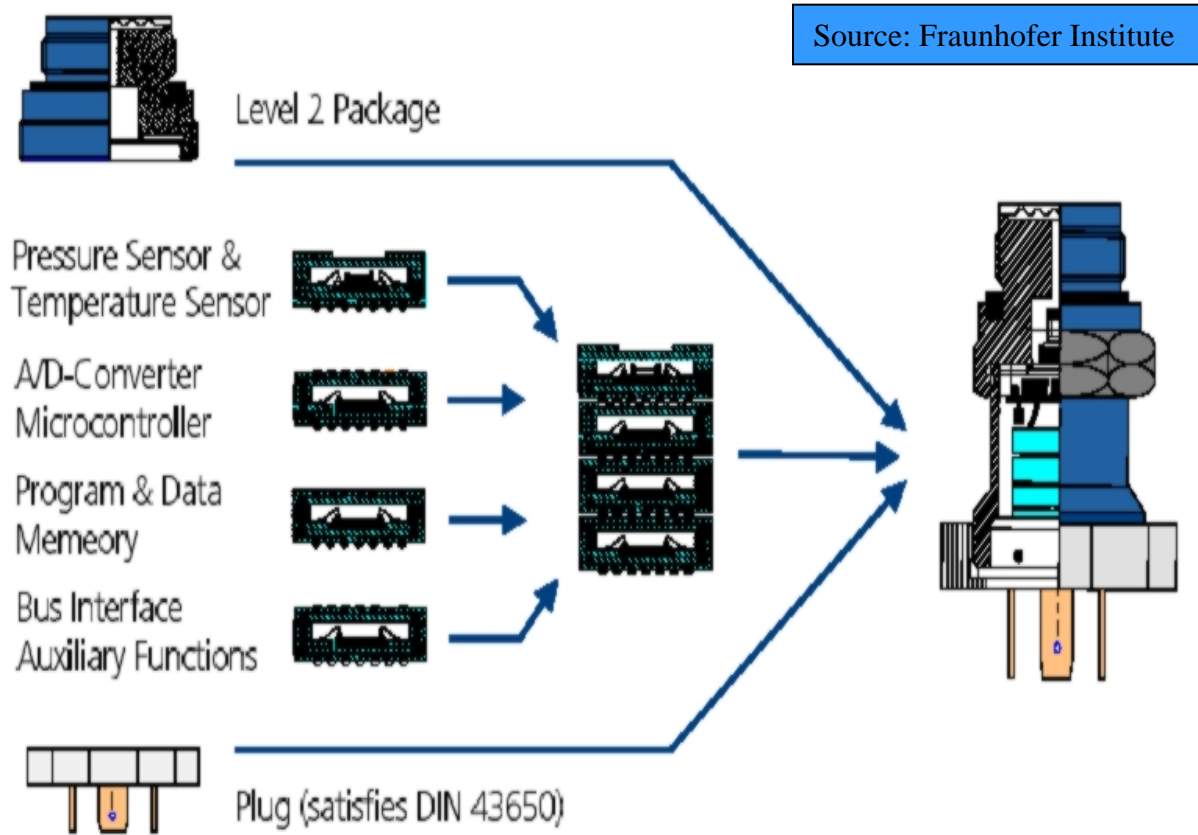

Figure 20: Modularized Smart Pressure Control System

HIERARQUIA DO ENCAPSULAMENTO ELETRÔNICO

- Nível 0
 - “Dies” (Circuitos integrados)
- Nível 1
 - A nível de “CHIP”
- **Nível 2**
 - **A nível de Circuito impresso**
- Nível 3
 - A nível de arranjo de circuito impresso
- Nível 4
 - A nível de Sistema

Universidade de São Paulo – Escola Politécnica

Mini-curso de Fabricação de Placas de Circuito Impresso

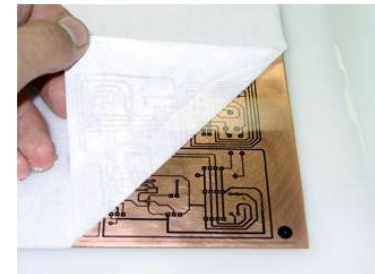

Do projeto ao circuito impresso

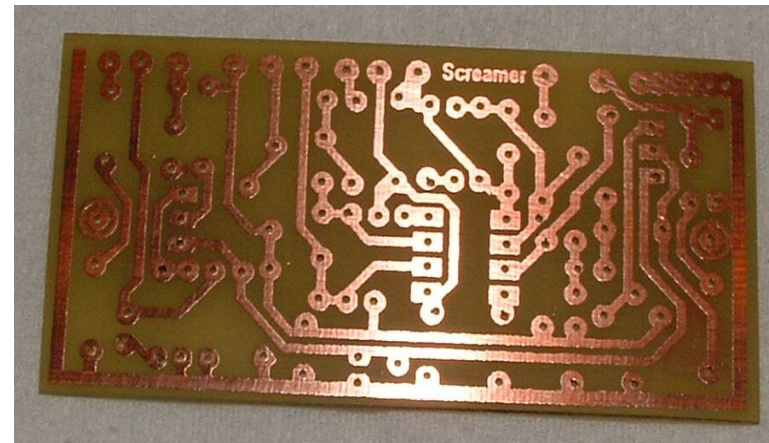
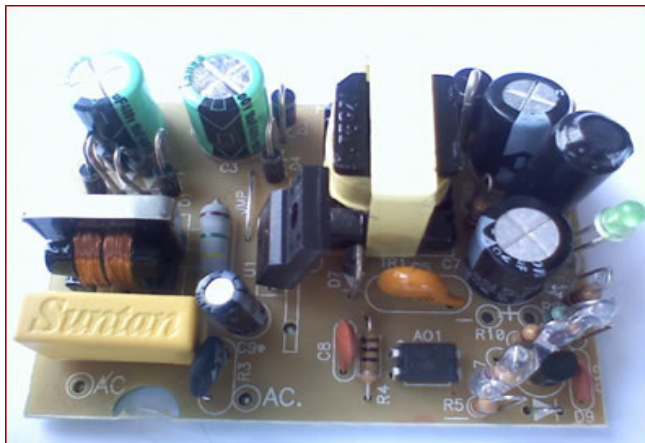
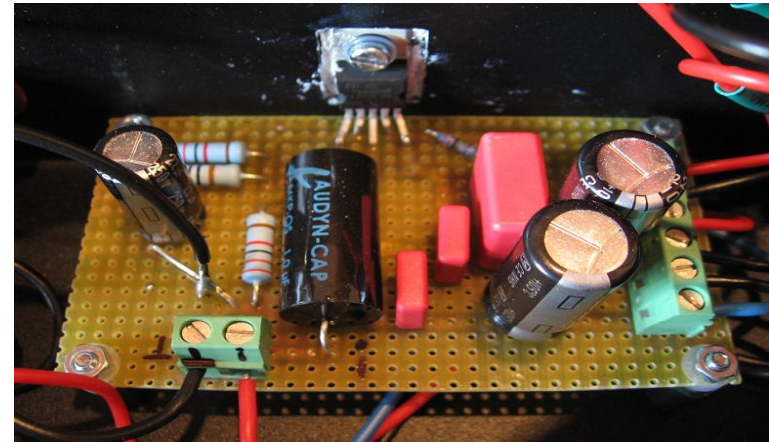
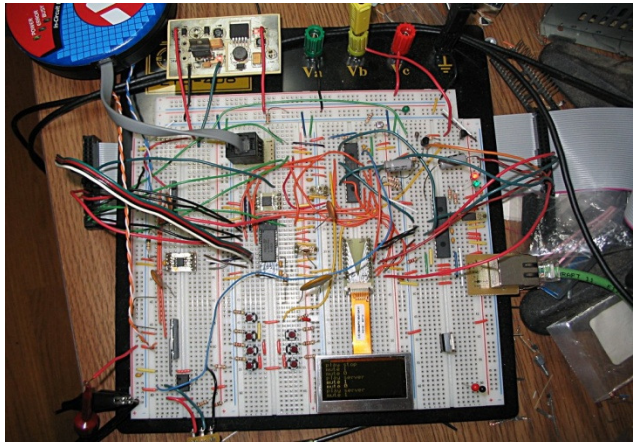

Protoboard

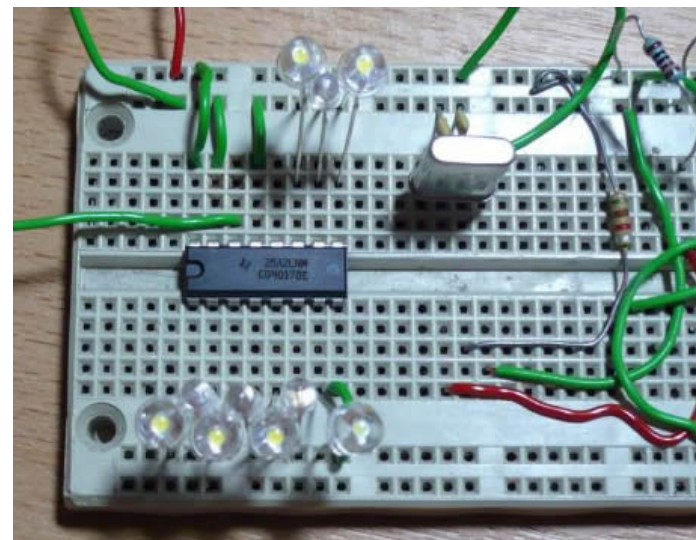
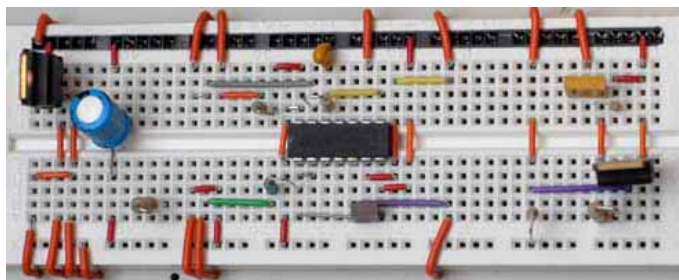
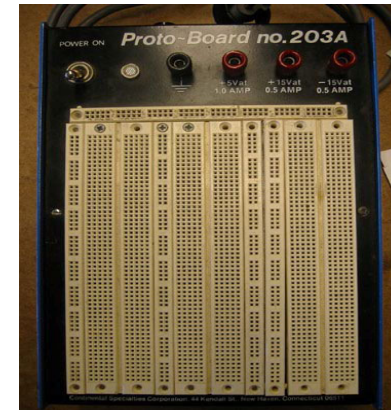
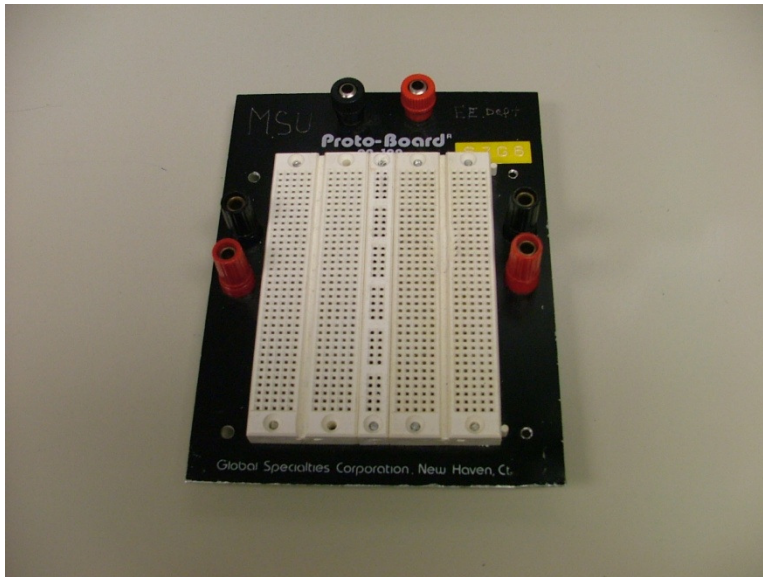

Placa padrão ou universal

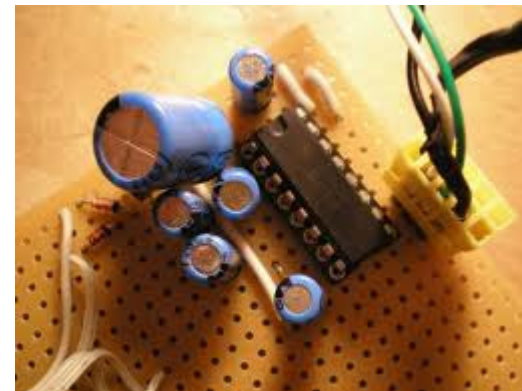
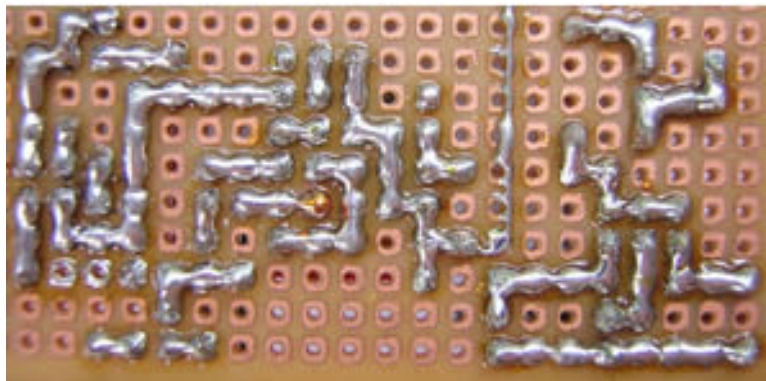
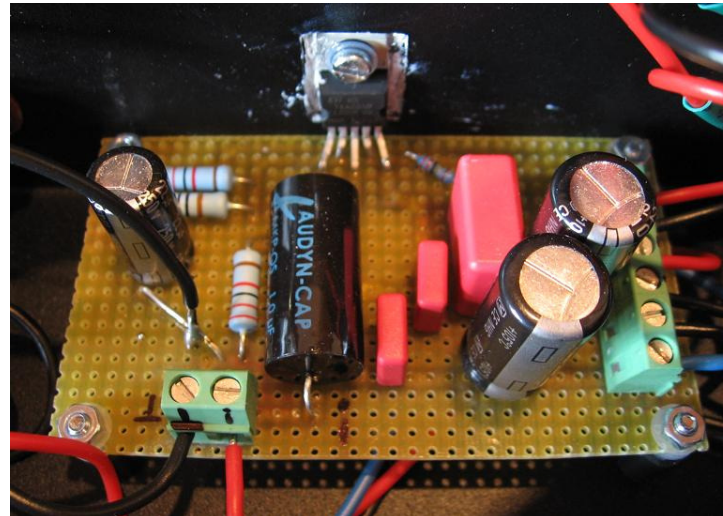
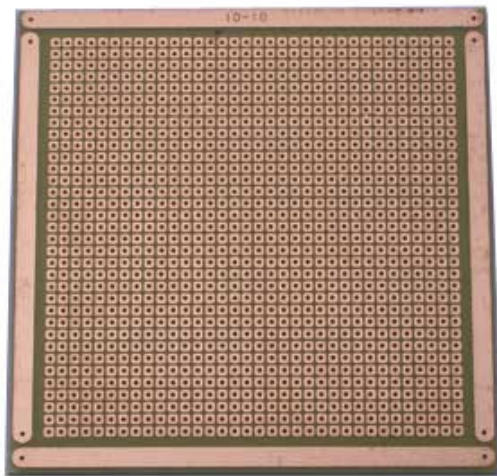

Placa de circuito impresso

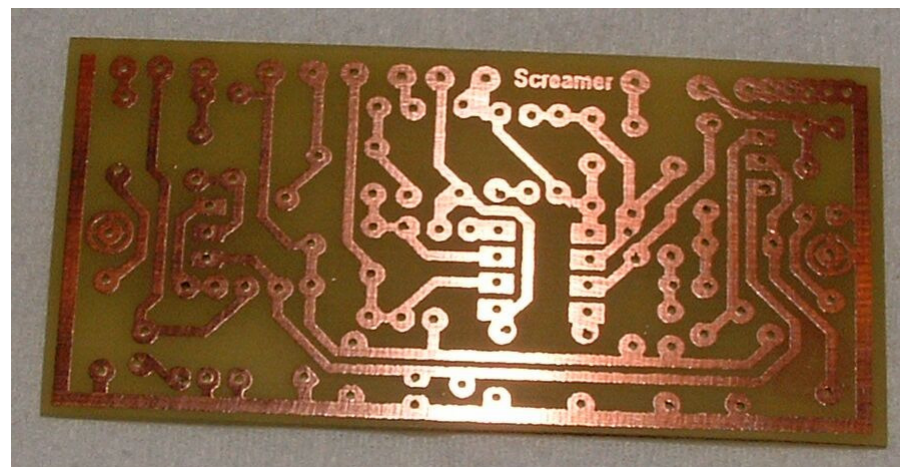
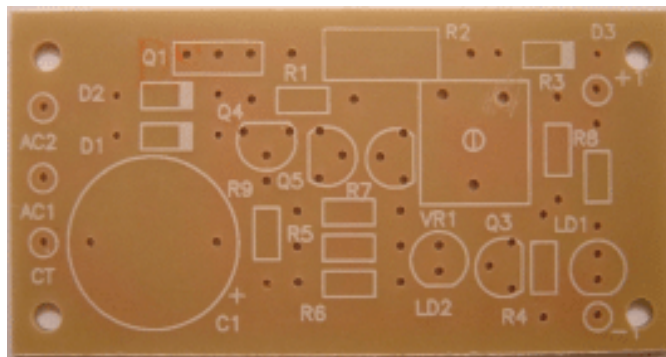
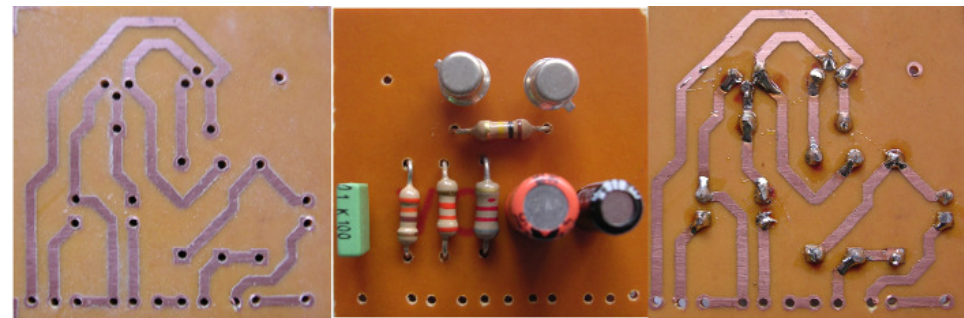

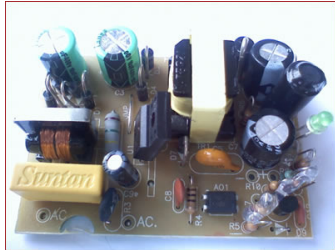

Por que fazer uma placa de circuito impresso?

- Minimizar a presença de ruído
- Eliminar maus-contatos oriundos da montagem em *protoboard*
- Dar reprodutibilidade ao circuito
- Caráter mais “profissional” do circuito final

Criando uma placa de circuito impresso

Como fazer o circuito?

Desenhar as trilhas e *footprints dos componentes sobre um* substrato de forma organizada, tentando minimizar as distâncias e o uso de *jumpers*.

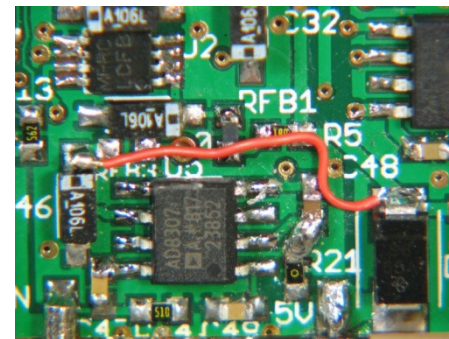
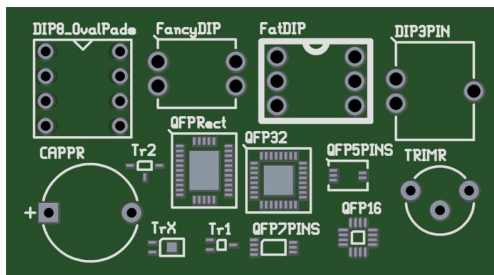

Desenhando a PCI: possibilidades

- Desenho feito à mão (forma mais simples e que dificulta a reprodutibilidade)

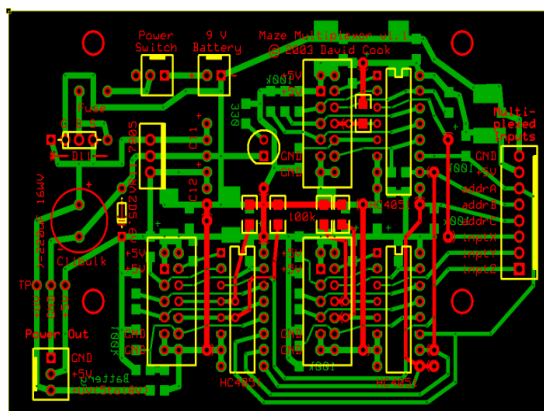

- Uso de softwares de auxílio ao projeto de PCIs (Eagle, OrCAD, Tango, Circuit Maker...)

Do *layout* à PCI: passo-a-passo

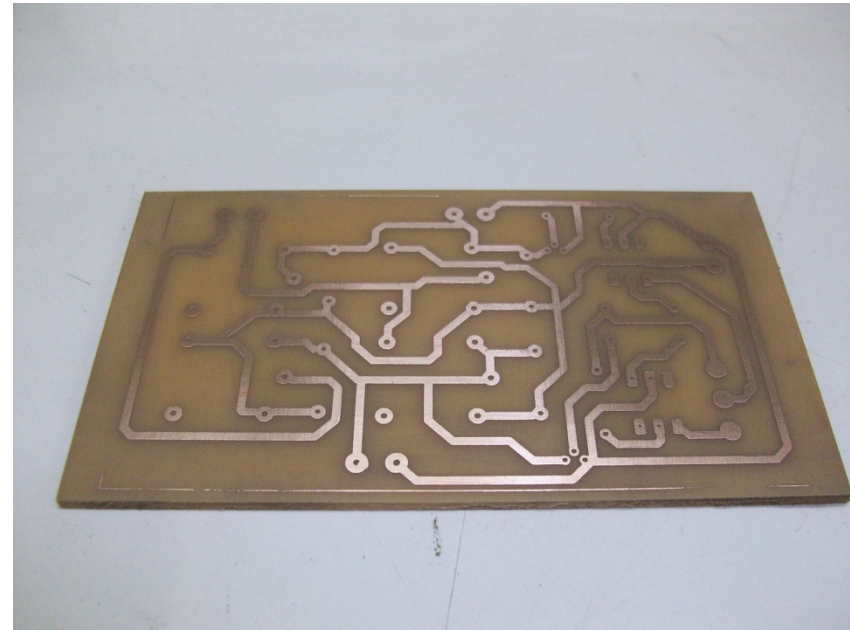
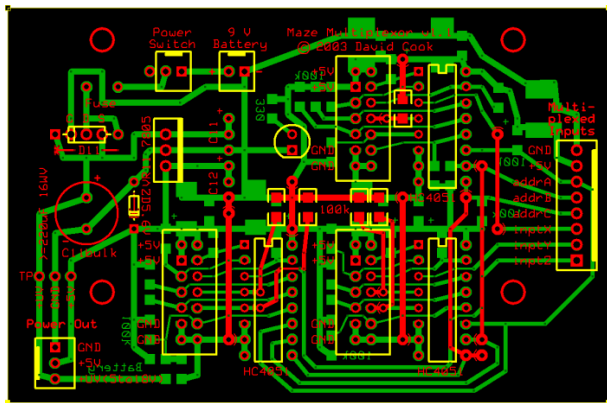

Desenhando o *layout* (1)

- Criar trilhas de alimentação, de terra e de *clock*.
 - Fazer as trilhas de alimentação com largura maior.
- Evitar trilhas muito longas.

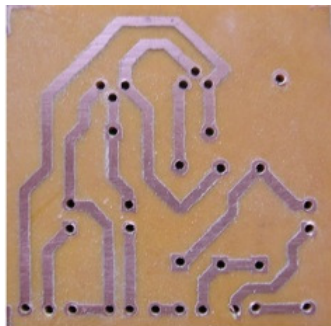

- Preferir mudanças de direção de 45° nas trilhas.

Desenhando o *layout* (2)

- Evitar que trilhas de sinais críticos (*clock* e altas frequências) fiquem paralelas por muito tempo.
- Evitar ligações diretas entre as entradas de alimentação de CIs.
- Usar *silk-screen*.

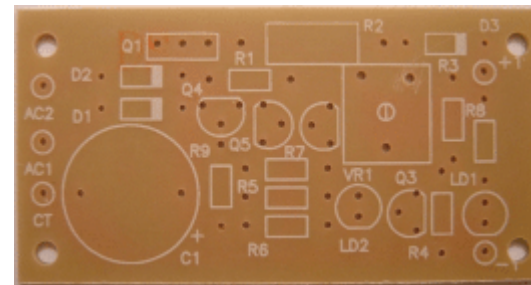

Criando trilhas de cobre

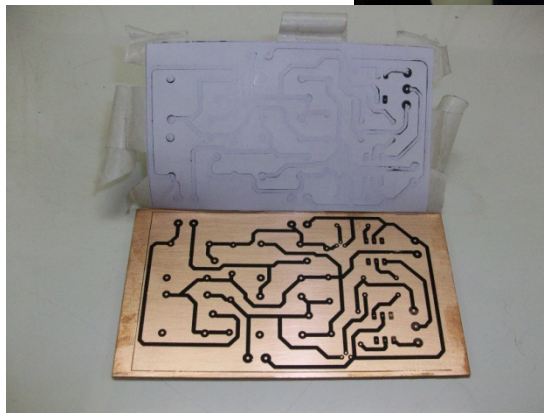
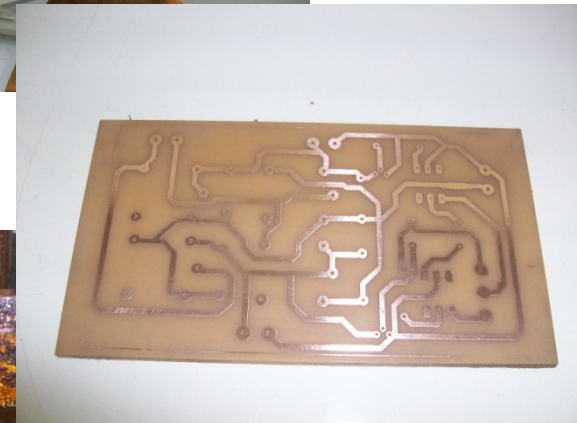
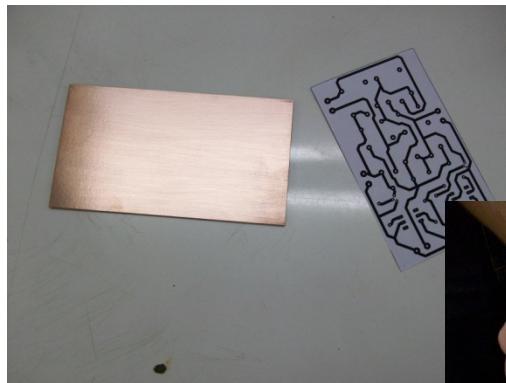

Impressão do *layout* no *transfer* (1)

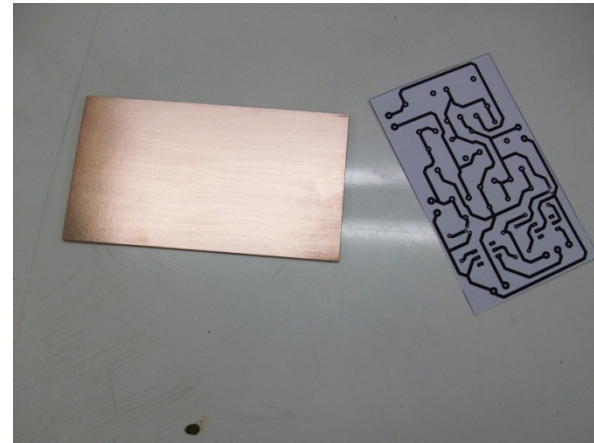

➔ Lixar a placa para melhorar a fixação do *transfer* no cobre



Impressão do *layout* no *transfer* (2)



Impressão do *layout* no *transfer* (3)

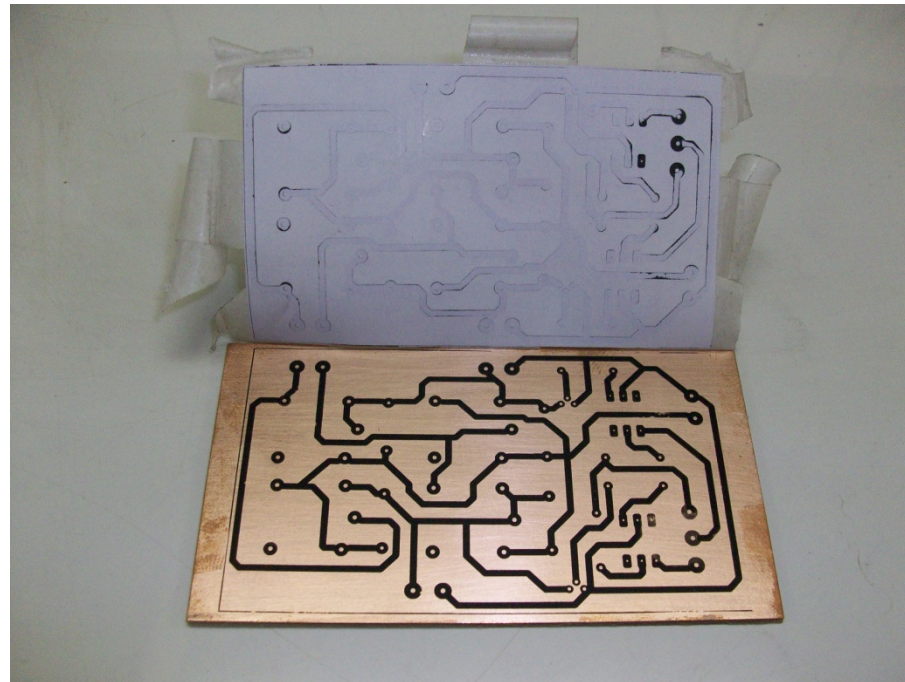

- ➔ Conferir se todas as trilhas são contínuas
- ➔ Completar trilhas descontínuas com a caneta

Corrosão do cobre

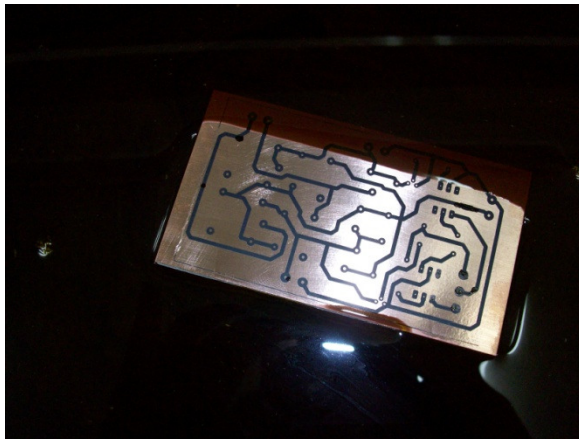

➡ CUIDADO!!! COLOCAR O PERCLORETO DE FERRO ANIDRO NA ÁGUA, E NÃO O INVERSO!

Remoção do *transfer* e finalização

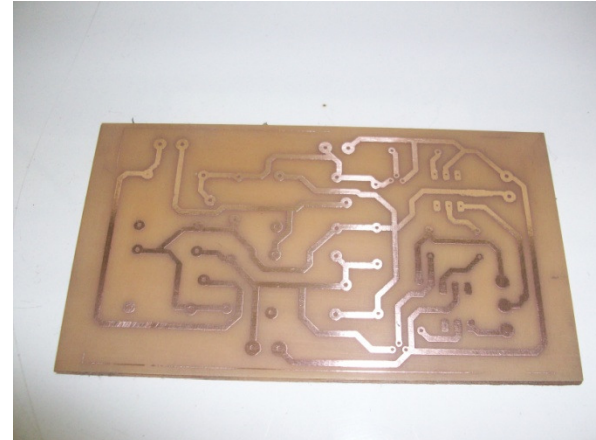
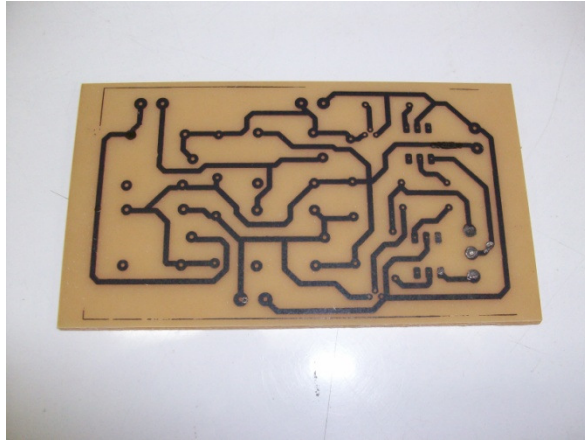

➔ Ao furar a placa, cuidado para não danificar as ilhas!



Dicas finais (1)

- Ao colocar o *transfer* sobre o substrato, centralizar o *layout* na placa, deixando espaço até as bordas
 - Fazer trilhas a mais, para o caso de precisar alterar o circuito
- Colocar um LED indicando que a placa está energizada



Dicas finais (2)

- Colocar pontos de acesso para medir com o osciloscópio

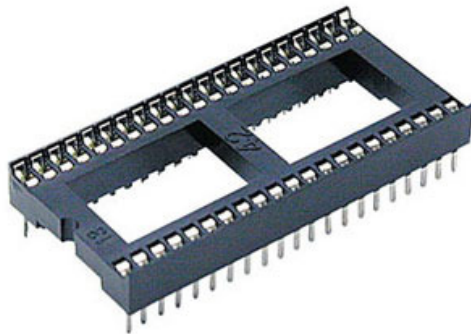
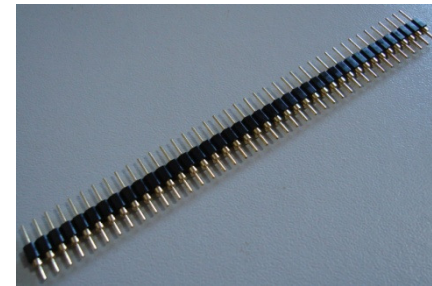

- Usar soquetes para os CIs

Informações úteis (1)



- Para fazer o download do Eagle:
 - <http://www.cadsoft.de/download.htm>

- Tutoriais do Eagle:
 - Tutorial do Eagle, junto ao próprio programa
 - <http://www.eletrica.ufpr.br/mehl/pci/apostila3cc.pdf>
 - http://www.py2ph.qrp-br.com/arquivos_diversos/tutorialpara-gerar_PCI_reduzido.pdf

Informações úteis (2)



- ➔ Para fazer compras de materiais: entorno da Santa Ifigênia
- ➔ A Rua dos Timbiras é uma boa opção para comprar placas de fenolite, brocas de 0.8 mm e componentes diversos
- ➔ Brocas também podem ser compradas na Odonto

Exemplo com o Eagle

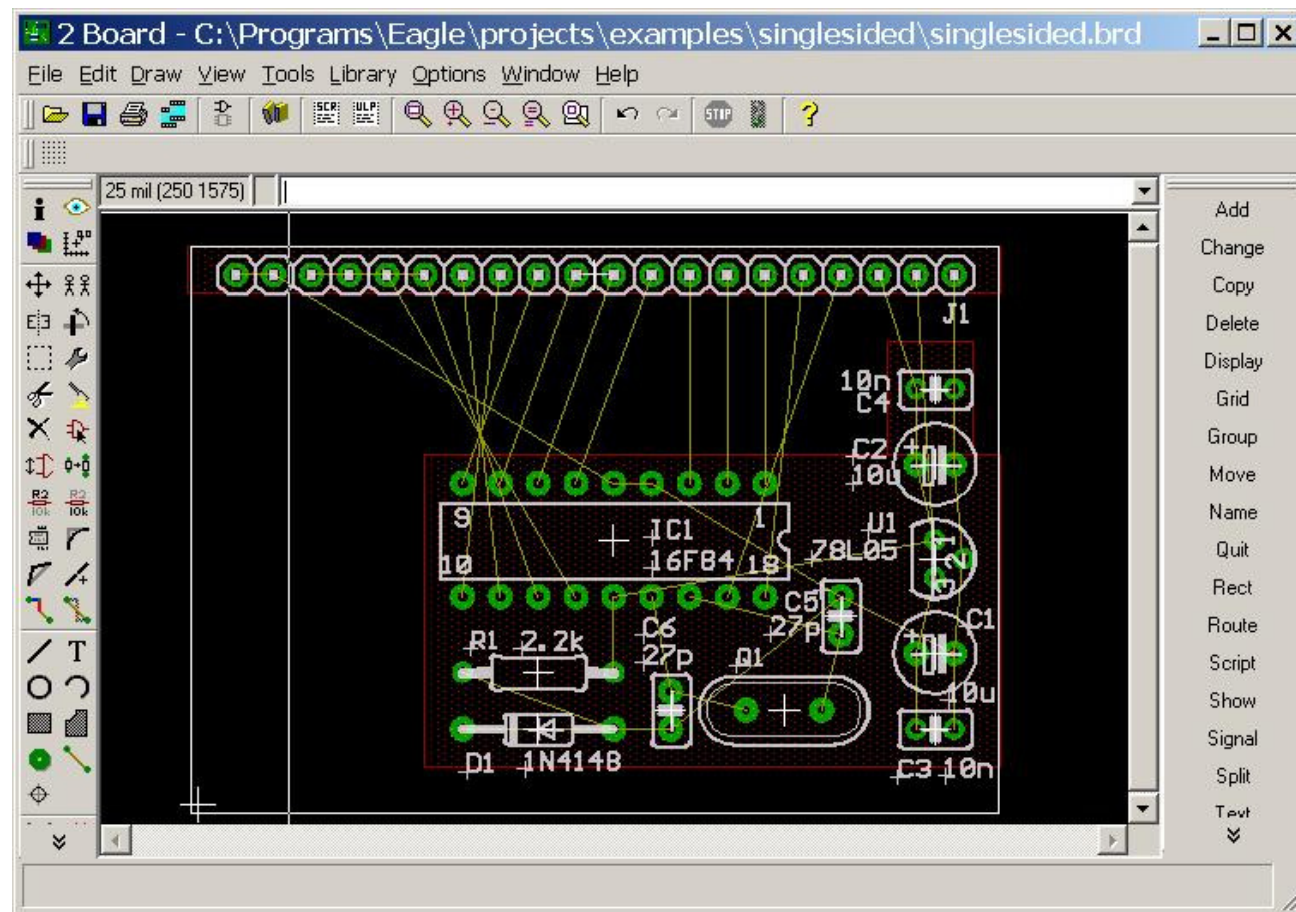

Modelo esquemático

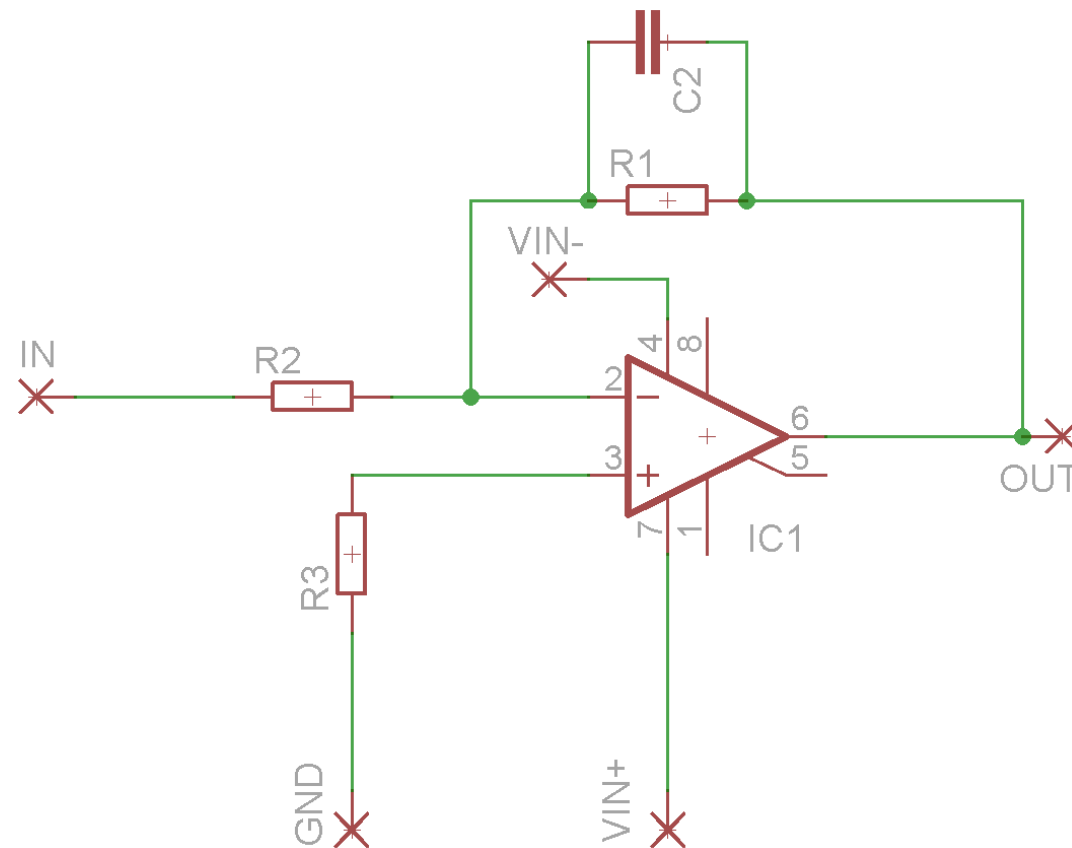

Filtro passa-baixa analógico de primeira ordem

Layout feito com o Eagle

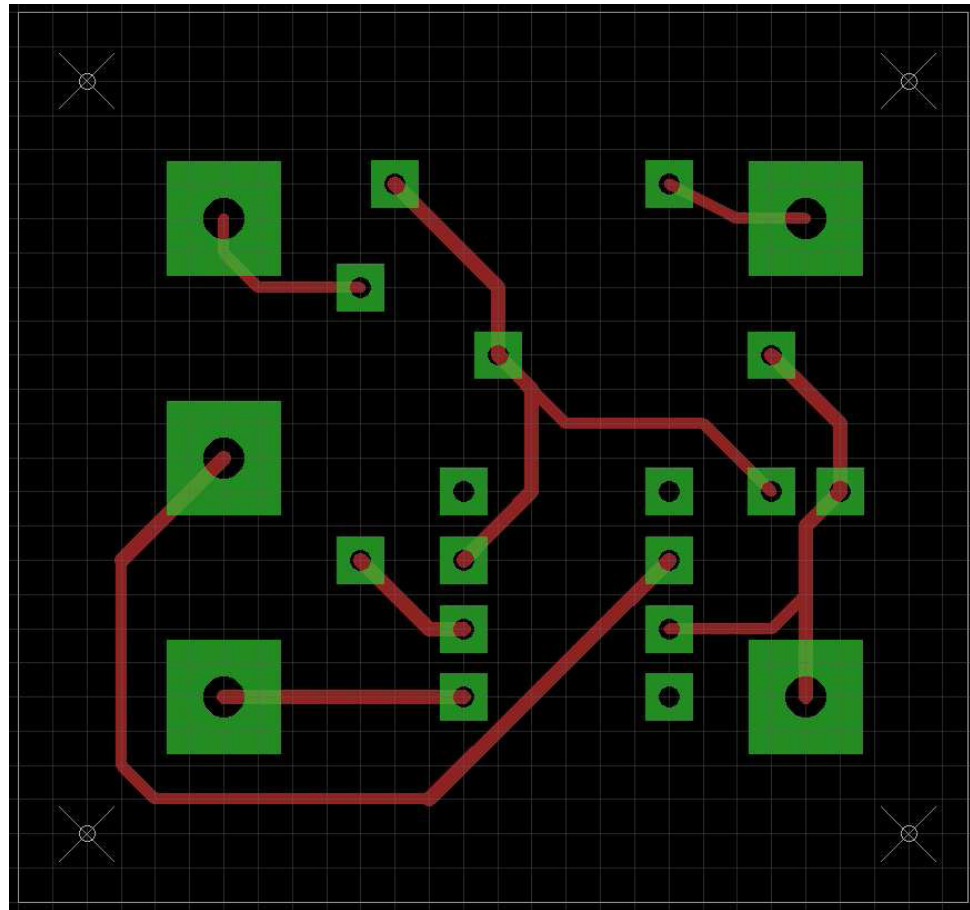

Referências

- ➔ Practical Electronics for Inventors - Paul Sherz
- ➔ The Circuit Designer's Companion - Tim Williams

