

DESENHO TÉCNICO PARA QUÍMICOS (SEM 0574)



Notas de Aulas v.2020



Prof. Alessandro Roger
Prof. Jaime Duduch
Profa. Luciana Montanari
Prof. Renato Jasinevicius

Aula 08 – Nocões de soldagem e simbologia



Casos Reais de Soldagem



Casos Reais de Soldagem

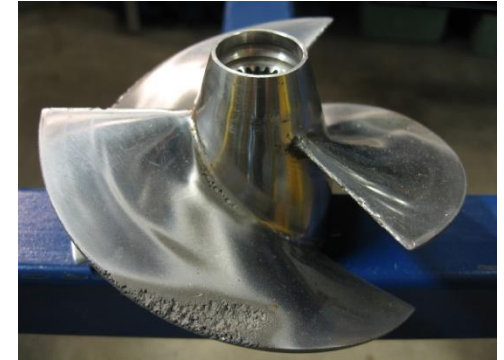
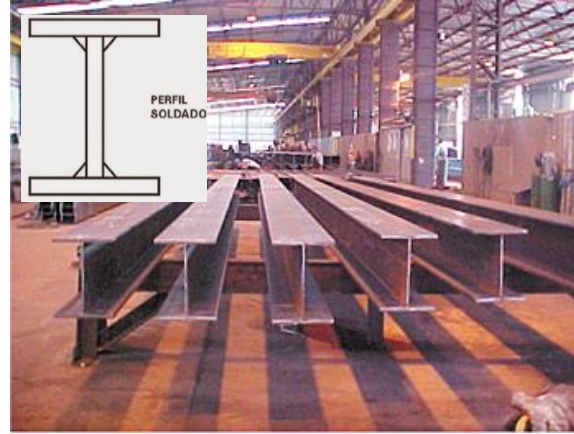

Cordão de solda



Soldagem

Processo de união de peças metálicas, cujas superfícies tornam-se liquefeitas pela ação do calor e/ou pressão, com ou sem adição de metal.

Processos de Soldagem

1. Soldagem por chama:

- Um dos mais antigos
- Baixo custo
- Aquecimento das peças a soldar
- Oxigênio e acetileno
- Com ou sem adição de material

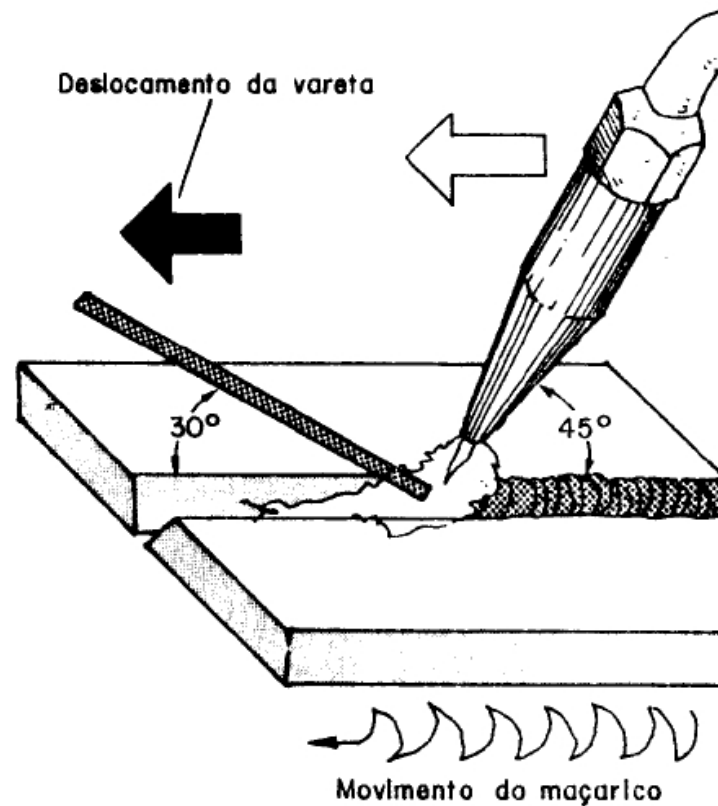

Posições de soldagem



(a)

Topo com flange

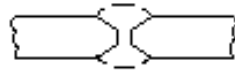

(d)

Topo em duplo V



(g)

Sobreposta

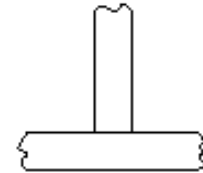

(j)

Em T

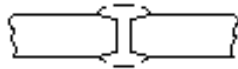

(b)

Topo reta



(e)

Topo em U

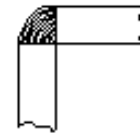

(h)

De centro

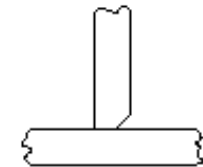

(k)

Em T

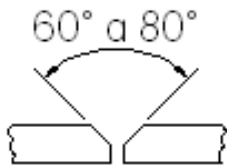

(c)

Topo em V

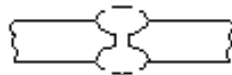

(f)

Topo em duplo U

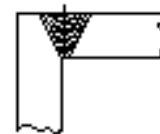

(i)



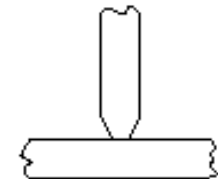



De canto





(l)





















Em T

Símbolos Básicos













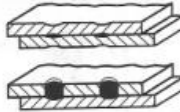





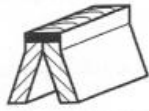

SÍMBOLOS BÁSICOS					
SEM PREPARAÇÃO		COM PREPARAÇÃO			
FILETE OU CANTO	SEM CHANFRO	V	BISEL	U	J
					

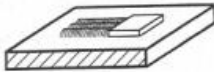
SÍMBOLOS COMPLEMENTARES	
SOLDA EM TODA VOLTA	SOLDA NO CAMPO (ou na montagem)
	

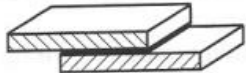
Preparação das juntas a serem soldadas (ex: chanfros, rasgos etc)

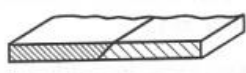
Designação	Ilustração	Símbolo
1 Junta de bordas rebordadas completamente fundidas		
2 Junta de borda reta		
3 Junta em V simples		
4 Junta em meio V simples		
5 Junta em Y simples		
6 Junta em meio Y simples		
7 Junta em tulipa (ou em U)		
8 Junta em meio U (ou em J)		
9 Cordão de confirmação na raiz da junta		
10 Junta em ângulo		



Designação	Ilustração	Símbolo
11 Soldagem em entalhe (ou perna de solda)		
12 Soldagem por pontos		
13 Soldagem em linha contínua		
14 Junta em V simples de bordas inclinadas		
15 Junta em meio V simples de bordas inclinadas		
16 Soldagem de borda		
17 Enchimento		
18 Junta de superfície		
19 Junta inclinada		
20 Junta dobrada		

Acabamento da solda após o processo de soldagem

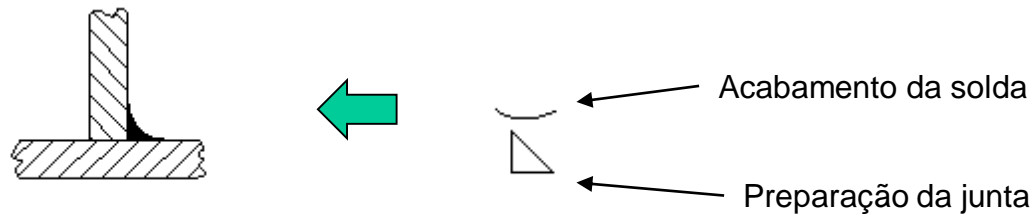
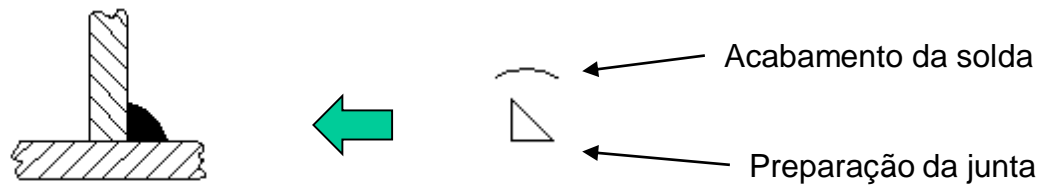
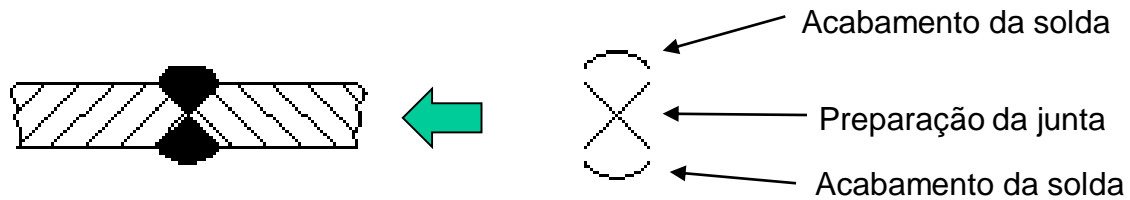
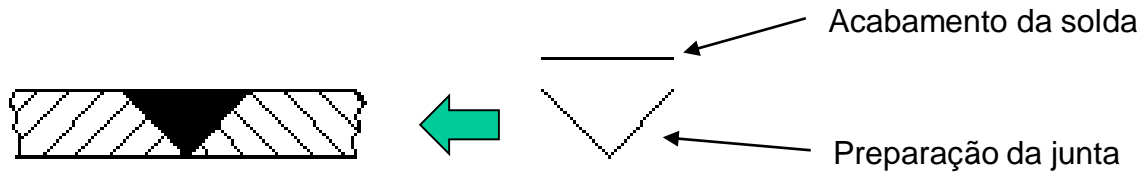

Simbologia

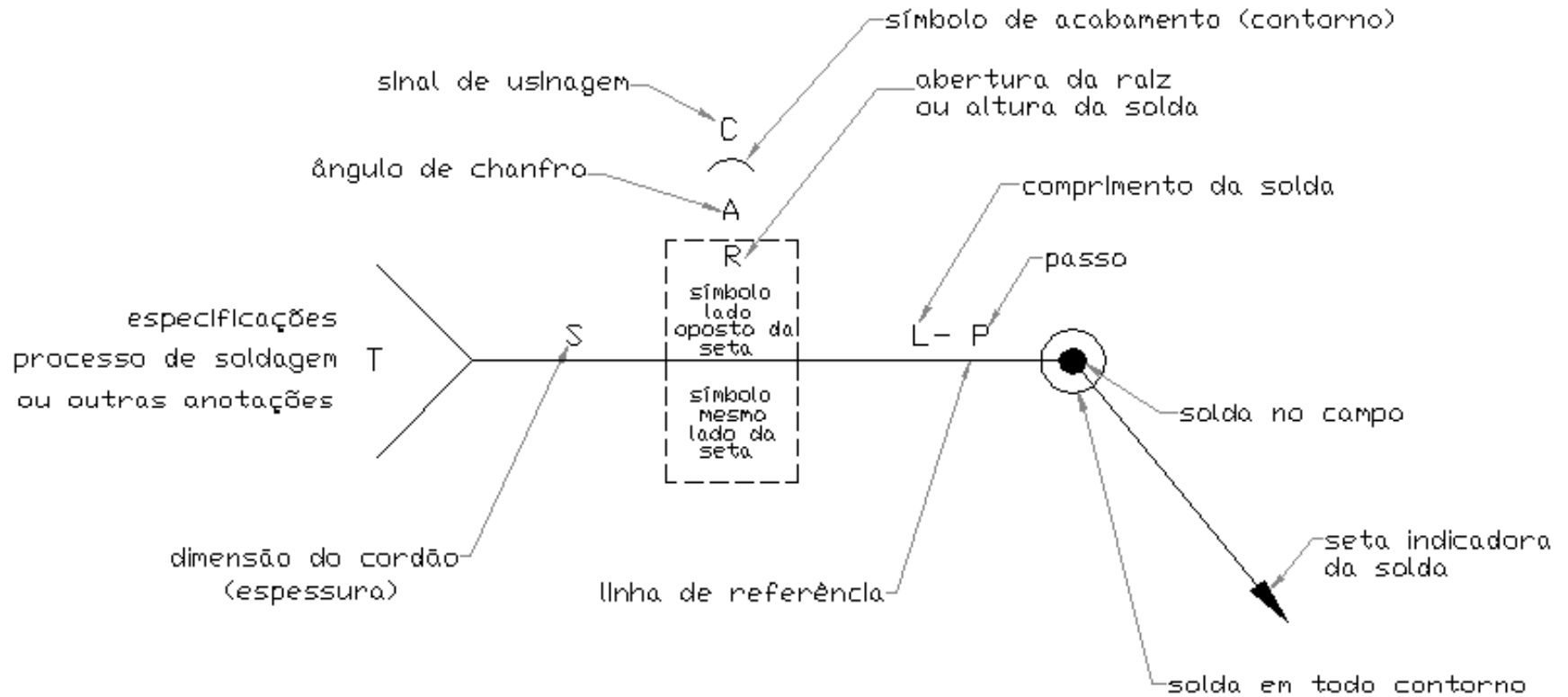

Dimensão da solda

Dimensões fundamentais a serem dadas nos símbolos de soldagem.

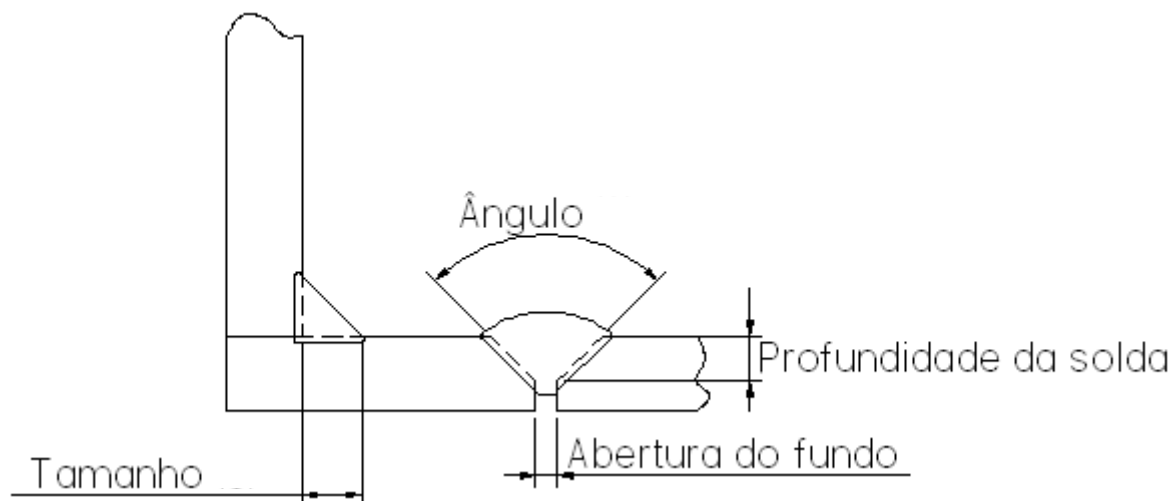



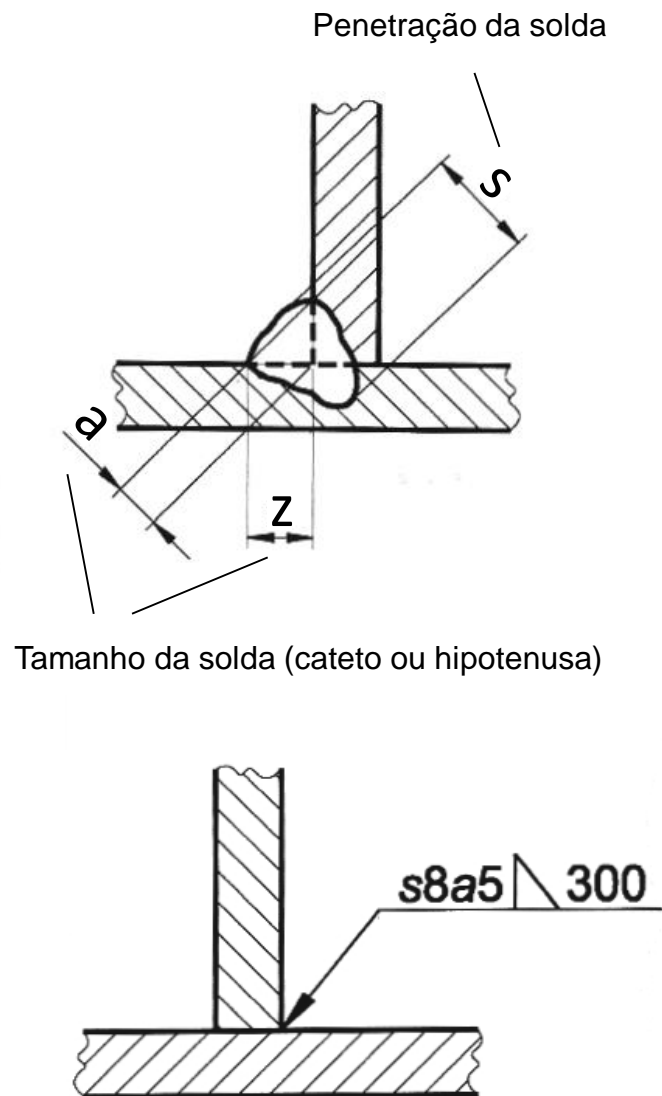
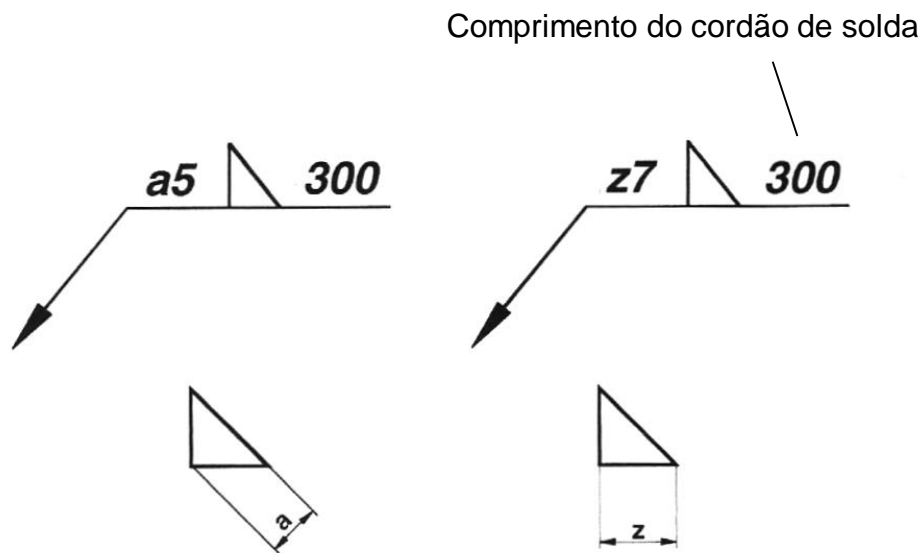

Cotagem dos Cordões de Solda

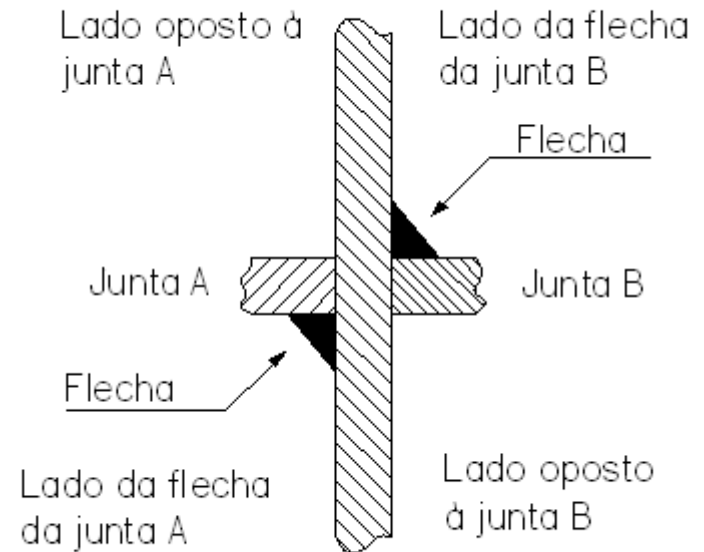
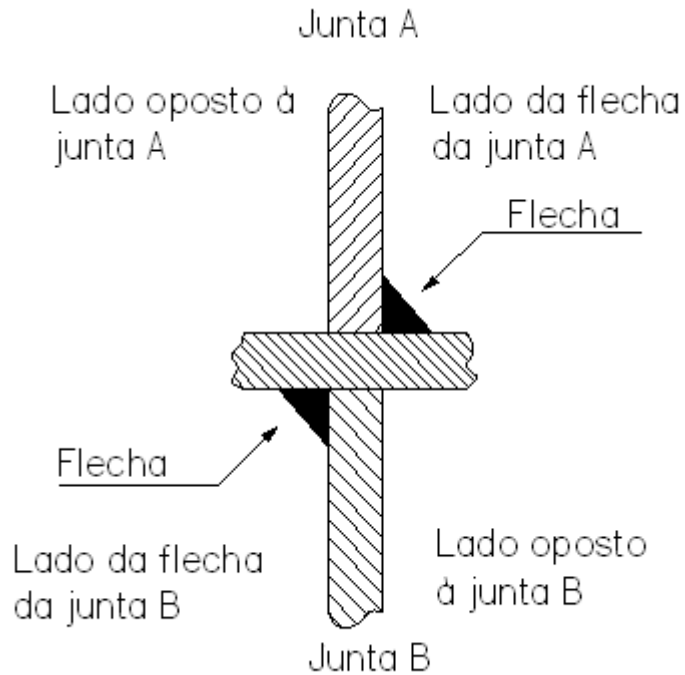

Em cruz com duas soldas em ângulo

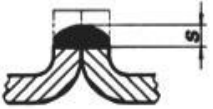

Outros Exemplos de Cotagem dos Cordões de Solda

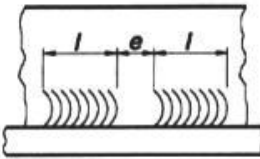
Designação	Ilustração	Inscrição
1 Junta de bordas		∇
		$s \parallel$
		$s \text{ Y}$
2 Junta de bordas retas		$s \parallel$
3 Juntas em ângulo contínuas		$a \triangle$ $z \triangle$
4 Junta em ângulo descontínua		$a \triangle n \text{ xl}(e)$ $z \triangle n \text{ xl}(e)$

Outros Exemplos de Cotagem dos Cordões de Solda

5 Junta em ângulo intermitente desfasada

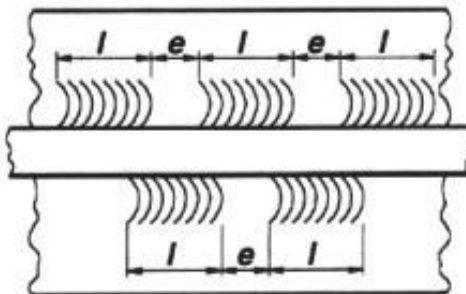

$$\frac{a}{a} \triangleright \left[\begin{array}{l} n \ x l \\ n \ x l \end{array} \right] (e)$$

$$\frac{z}{z} \triangleright \left[\begin{array}{l} n \ x l \\ n \ x l \end{array} \right] (e)$$

6 Soldagem em entalhe descontínua

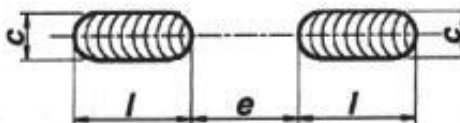

$$c \sqcap \left[n \ x l \right] (e)$$

7 Soldagem em linha descontínua

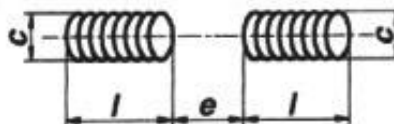

$$c \ominus \left[n \ x l \right] (e)$$

8 Soldagem por pontos

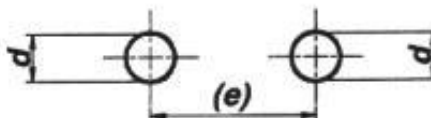

$$d \bigcirc n(e)$$

EXEMPLO – Uniões em T

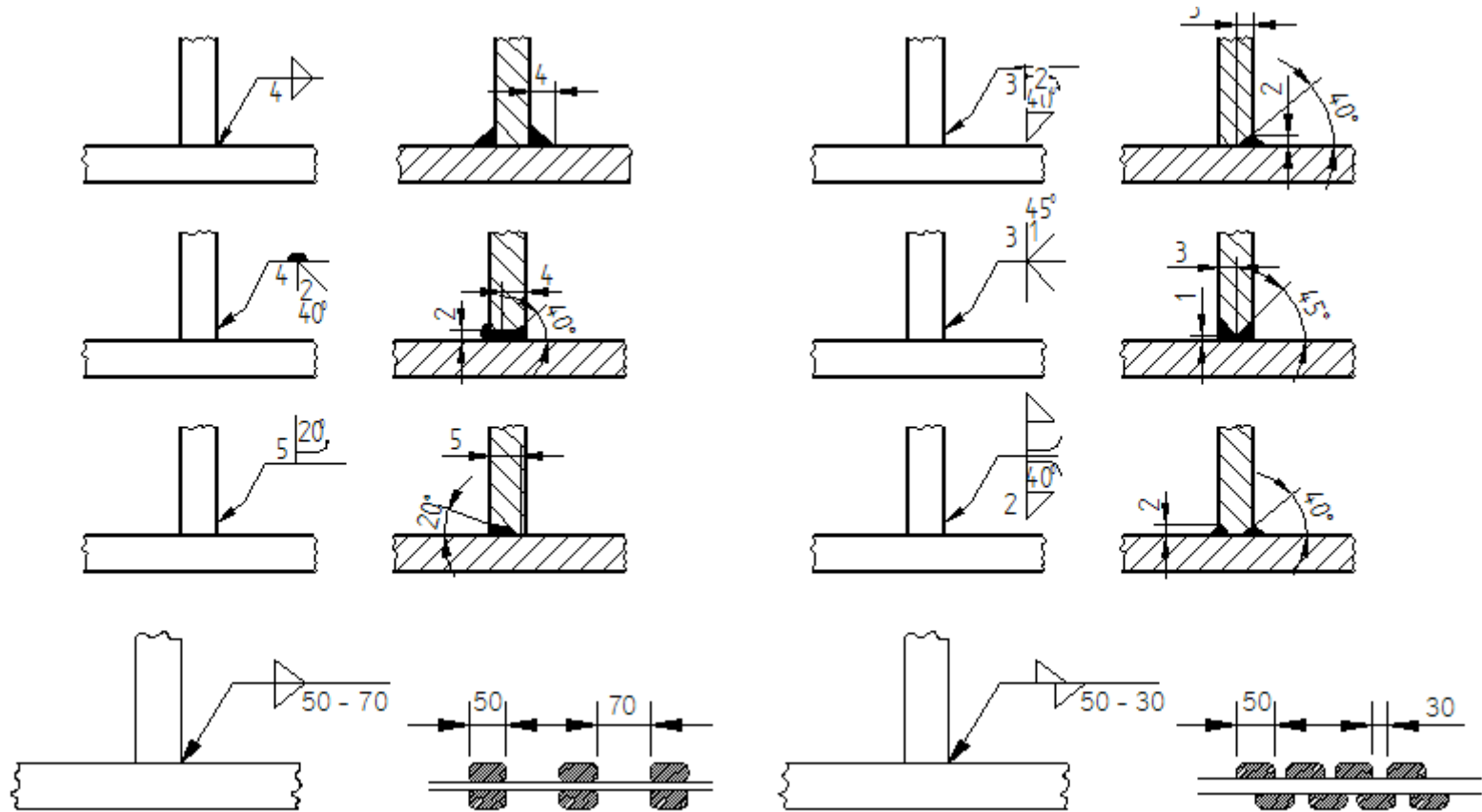

EXEMPLO – Uniões de Topo

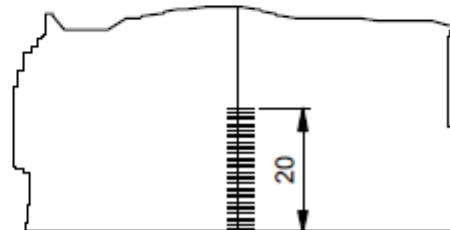
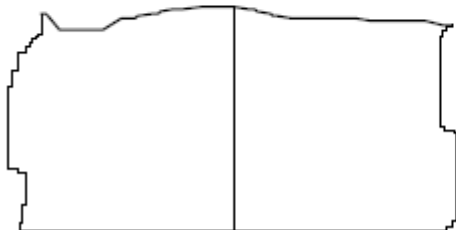
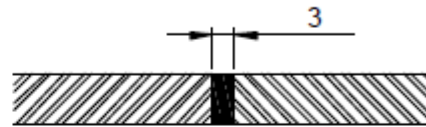
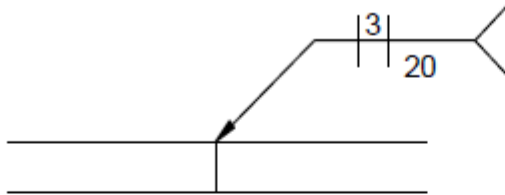
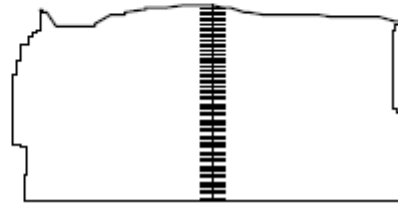
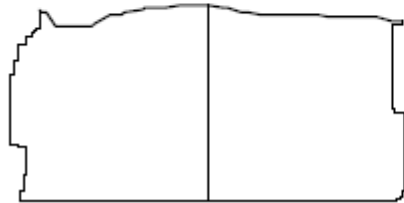
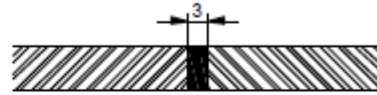
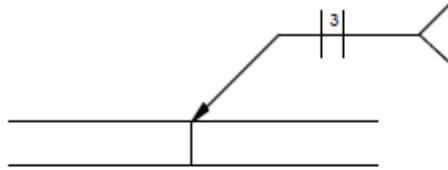

EXEMPLO – Uniões de Topo

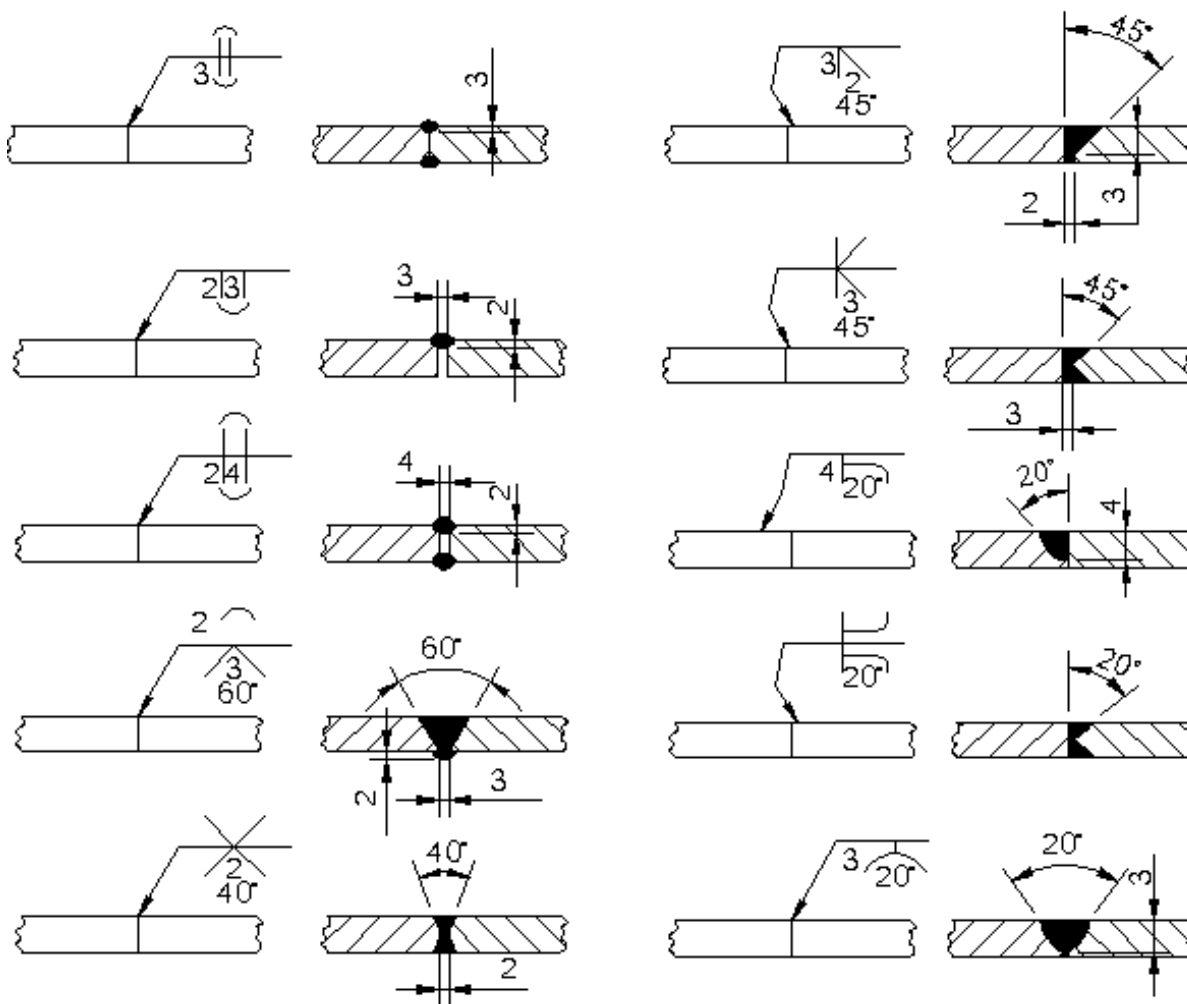

Exercício 52 - Usando a simbologia correta, referencie as soldas desenhadas à esquerda nas vistas laterais em corte

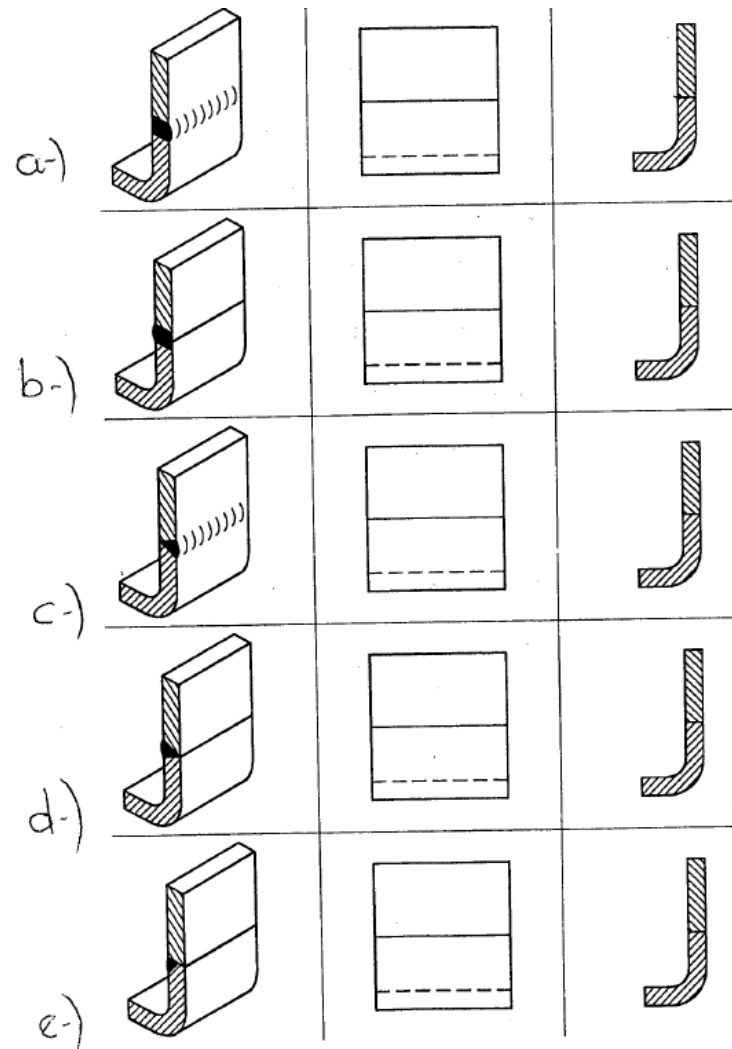

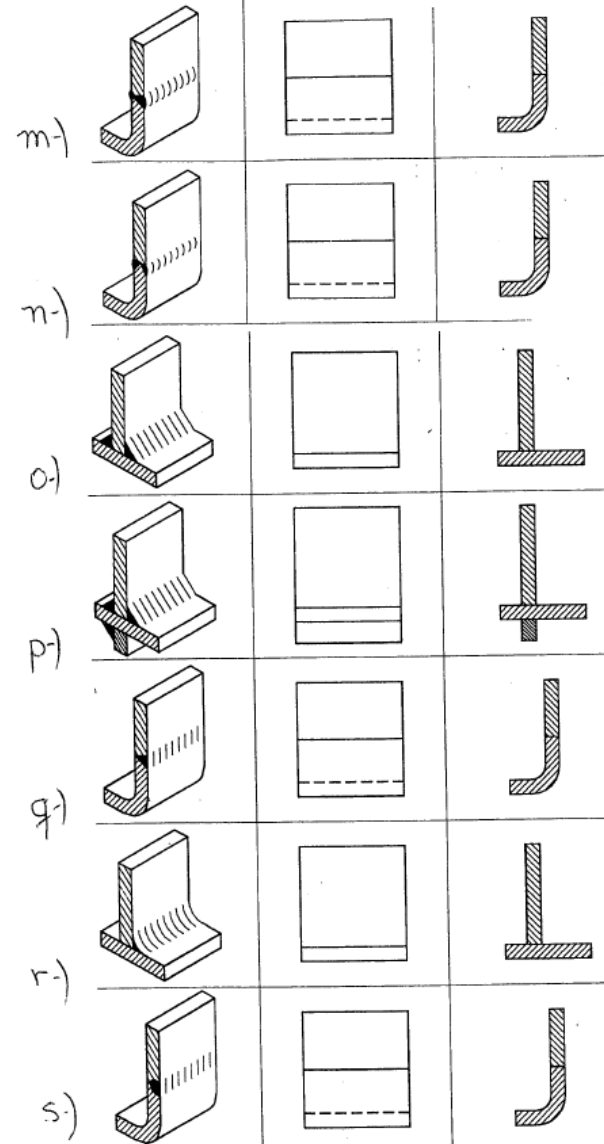
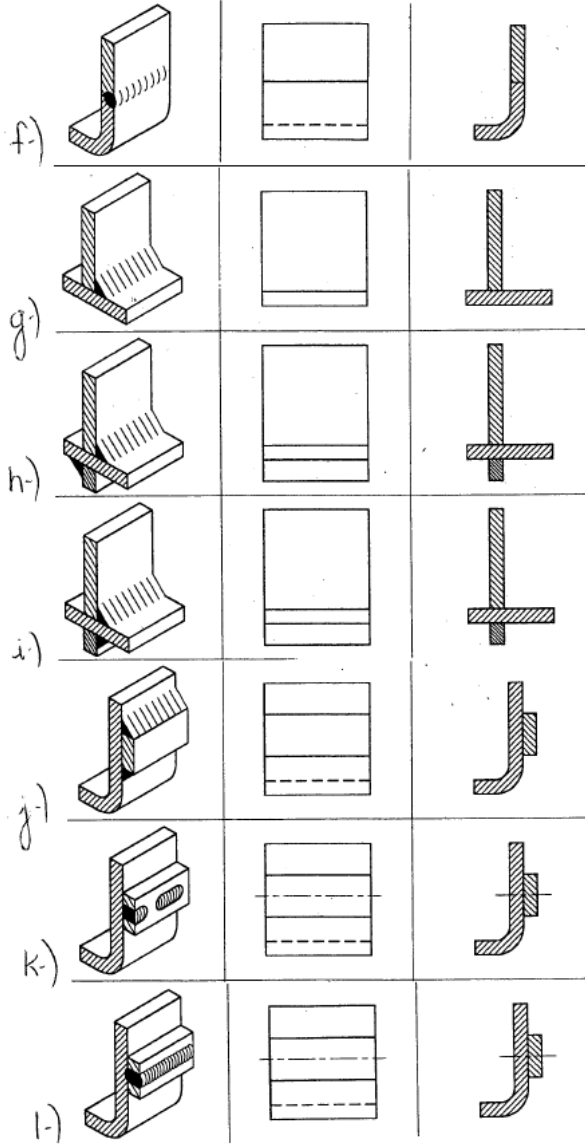

REFERÊNCIAS

Silva, A.; Ribeiro, C. T.; Dias, J.; Souza, L. **Desenho Técnico Moderno**, 4. ed., LTC Editora, 2006, 486 p.

Pauli, E. A.; Uliana, F. S. **Noções Básicas de Processos de Soldagem e Corte**, Escola SENAI-ES.