

SEM 0564 - DESENHO TÉCNICO MECÂNICO I

Notas de Aulas v.2020

Aula 07 – Componentes de fixação: parafusos, porcas, rebites e Soldas (noções de simbologia)

Prof. Assoc. Carlos Alberto Fortulan

Departamento de Engenharia Mecânica
Escola de Engenharia de São Carlos
Universidade de São Paulo

Roscas

É o conjunto de reentrâncias e saliências, com perfil constante, em forma helicoidal, que se desenvolve, externa ou internamente, ao redor de uma superfície cilíndrica ou cônica.

Saliências → filetes

Reentrâncias → vãos

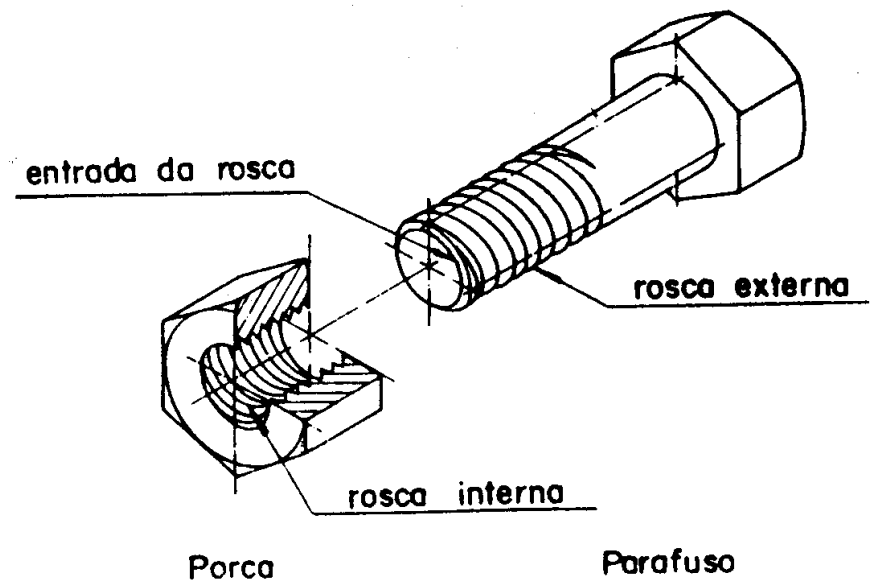
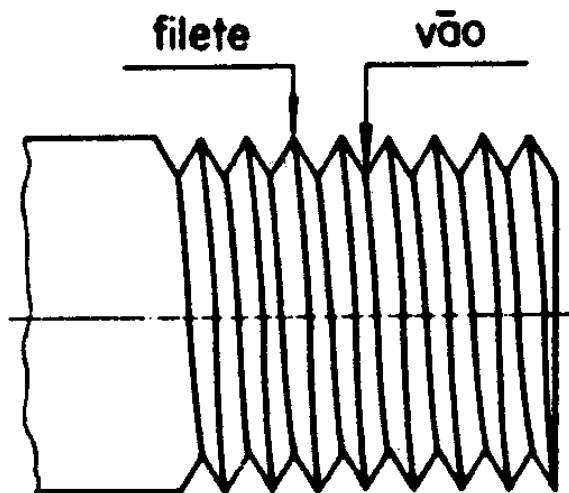

Elementos de uma rosca

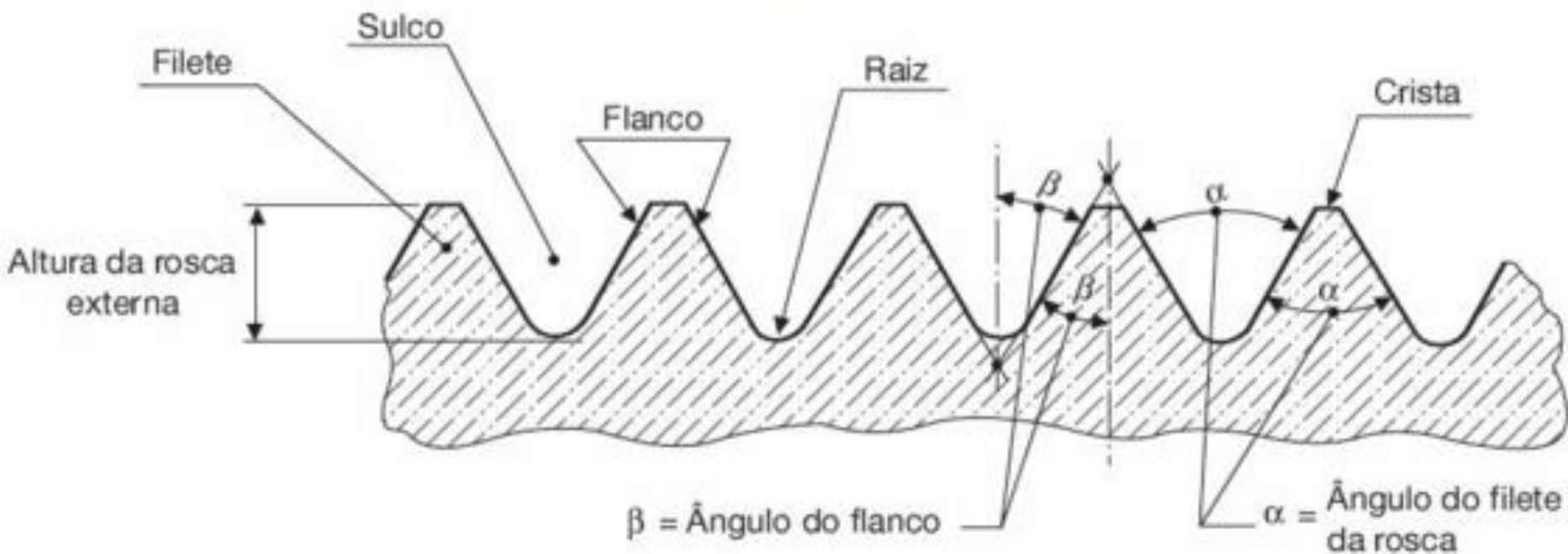

Perfil básico para roscas Métricas

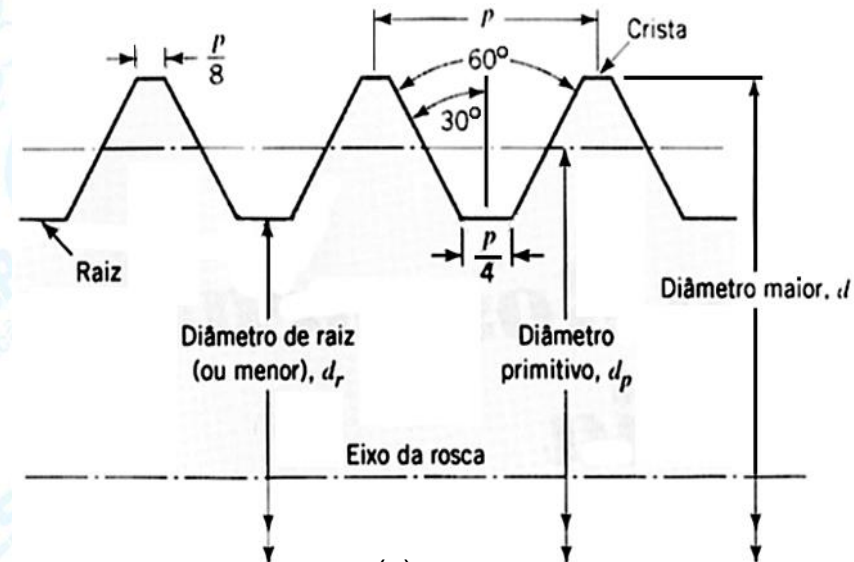
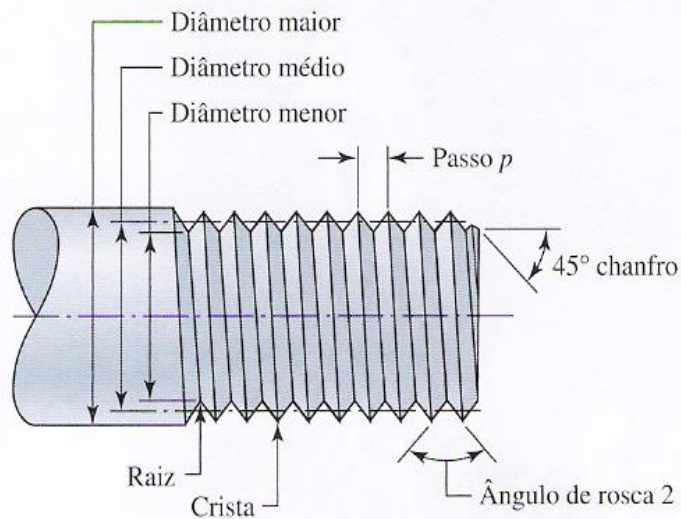

(a)

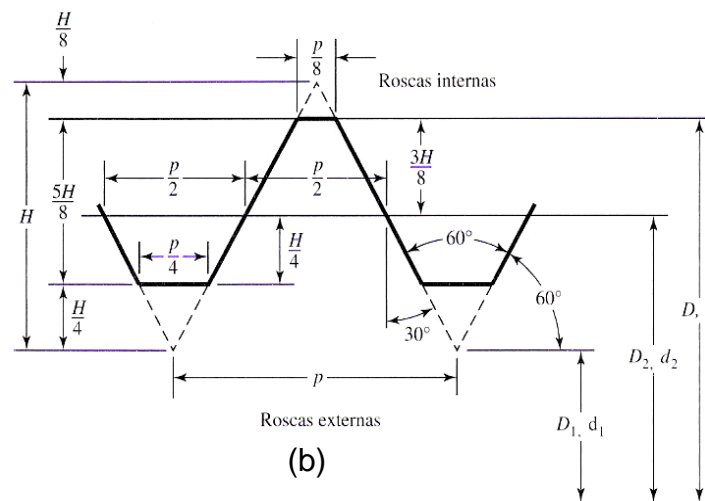

(b)

Shigley, 2006)

Entradas

Entrada: é o início da rosca. As roscas podem ter uma ou mais entradas e estas são usadas quando é necessário um avanço mais rápido do parafuso na porca ou vice-versa.

Avanço (A) é a distância que o parafuso ou porca percorre em relação a seu eixo, quando se completa uma rotação.

Rotação (B) é uma volta completa do parafuso ou da porca em relação a seu eixo. Quando o avanço é igual ao passo, a porca é de uma entrada.

Passo (P) é a distância entre dois filetes consecutivos.

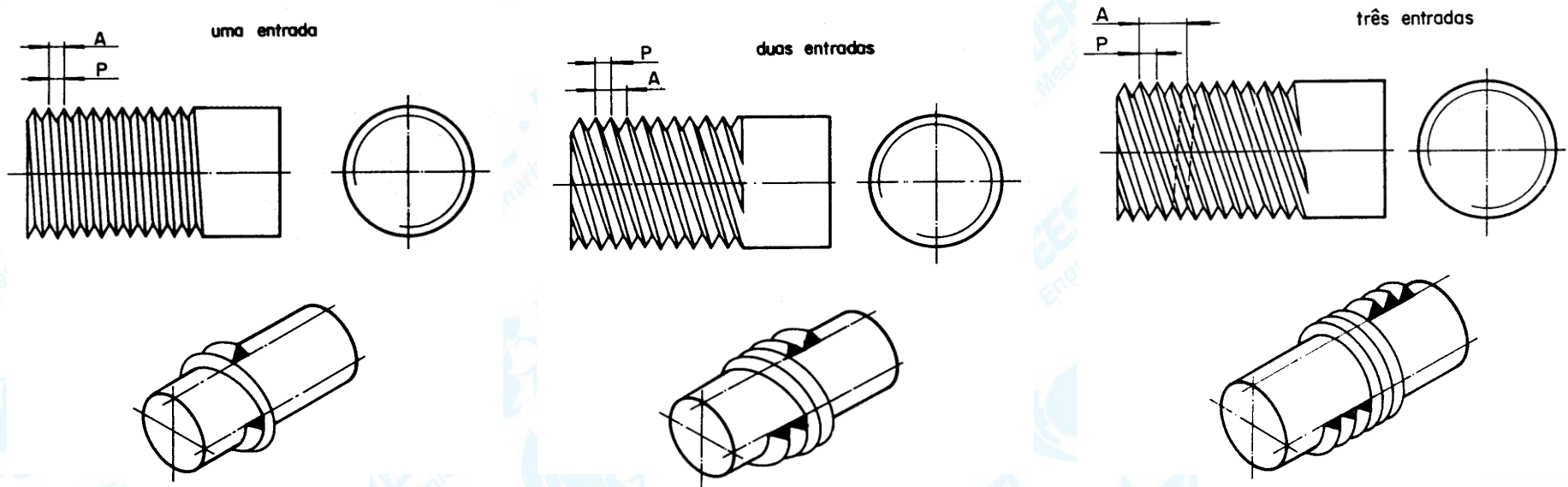

Sentido da rosca:

Rosca à direita é aquela em que o parafuso ou a porca avança girando no sentido dos ponteiros do relógio.

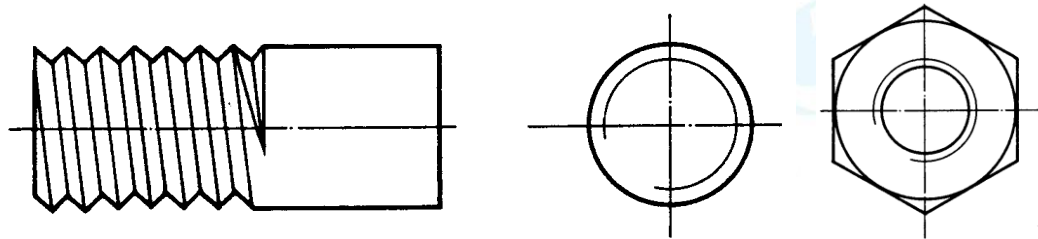

Rosca à esquerda é aquela em que o parafuso ou a porca avançam girando no sentido contrário ao dos ponteiros do relógio.

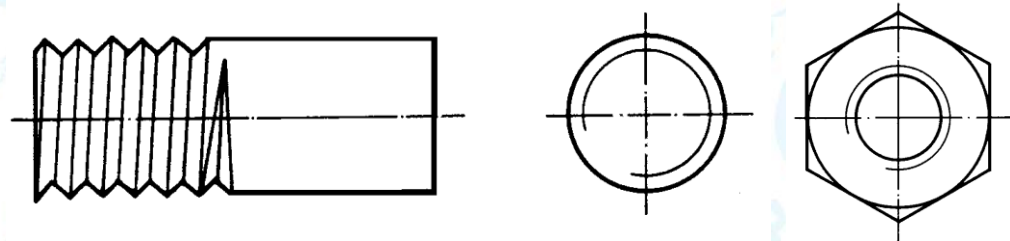

Representação de roscas

Normal

Rosca triangular

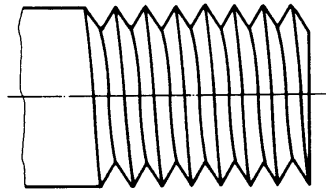

Rosca quadrada

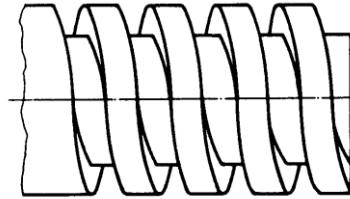

Rosca trapezoidal

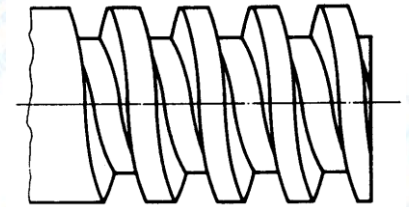

Perfil triangular

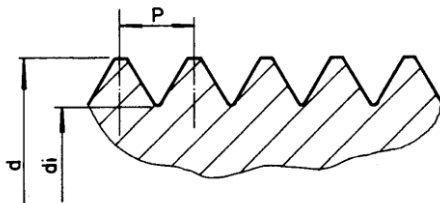

Perfil quadrado

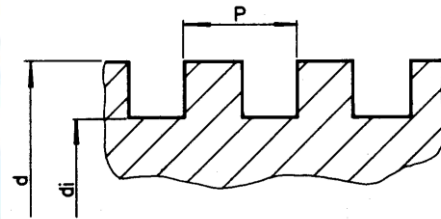

Perfil trapezoidal

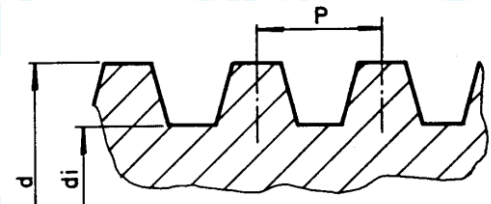

Por convenção

Rosca com perfil triangular

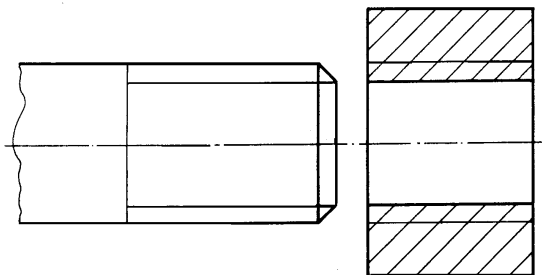

Rosca com perfil especial

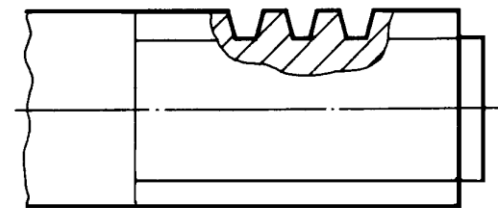

Convencional de furos roscados

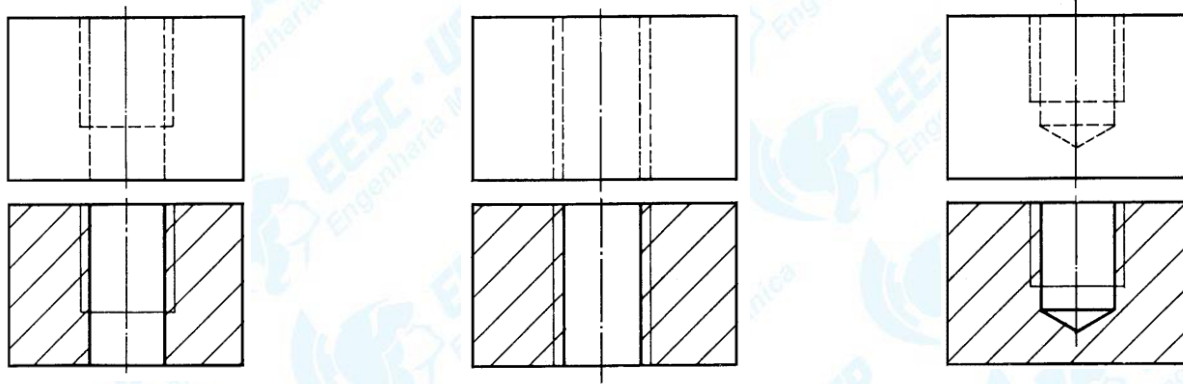

Unções por parafusos e porcas

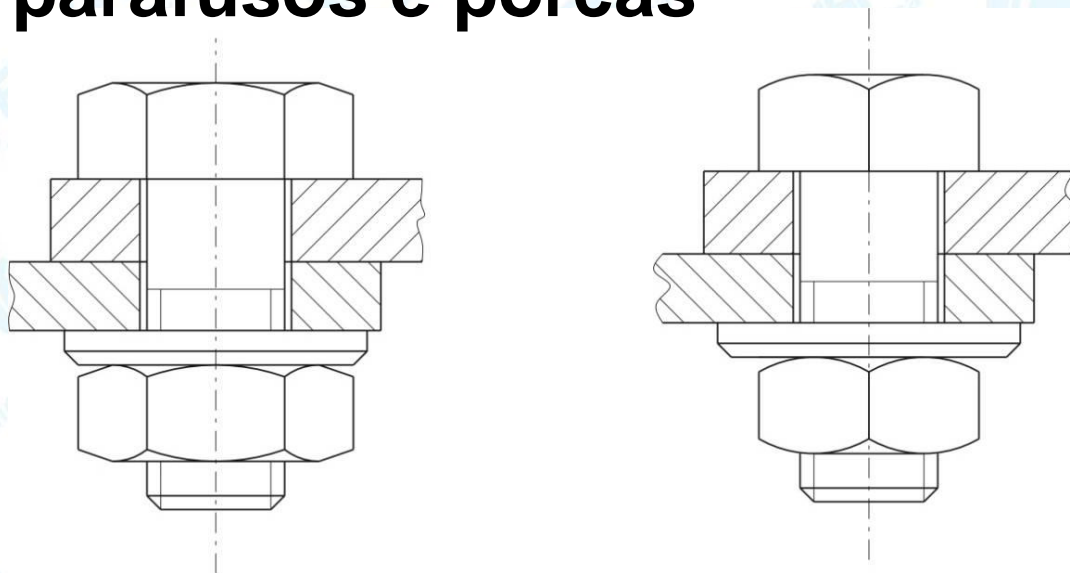

Unções por parafusos

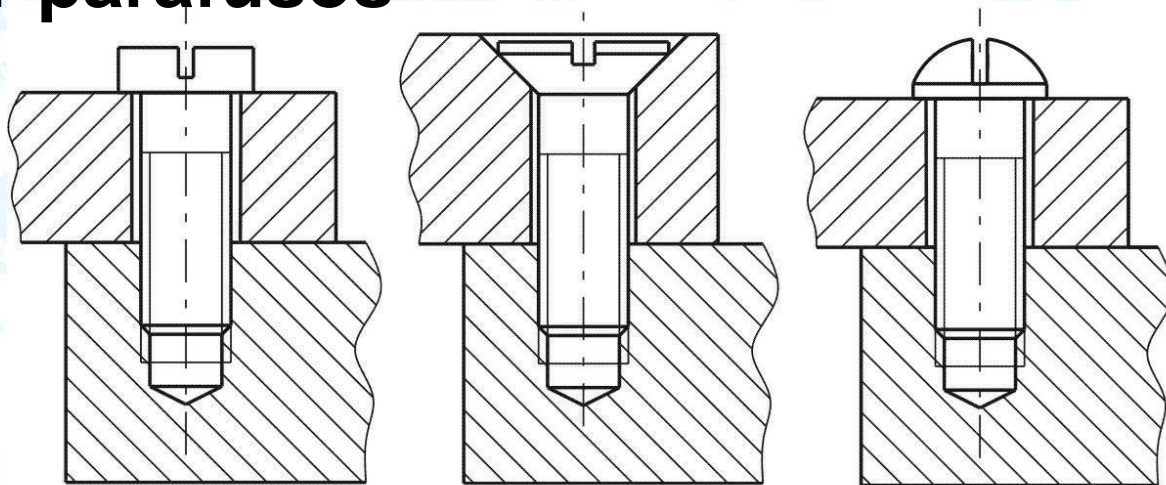

Furo roscado e união por prisioneiro e porca

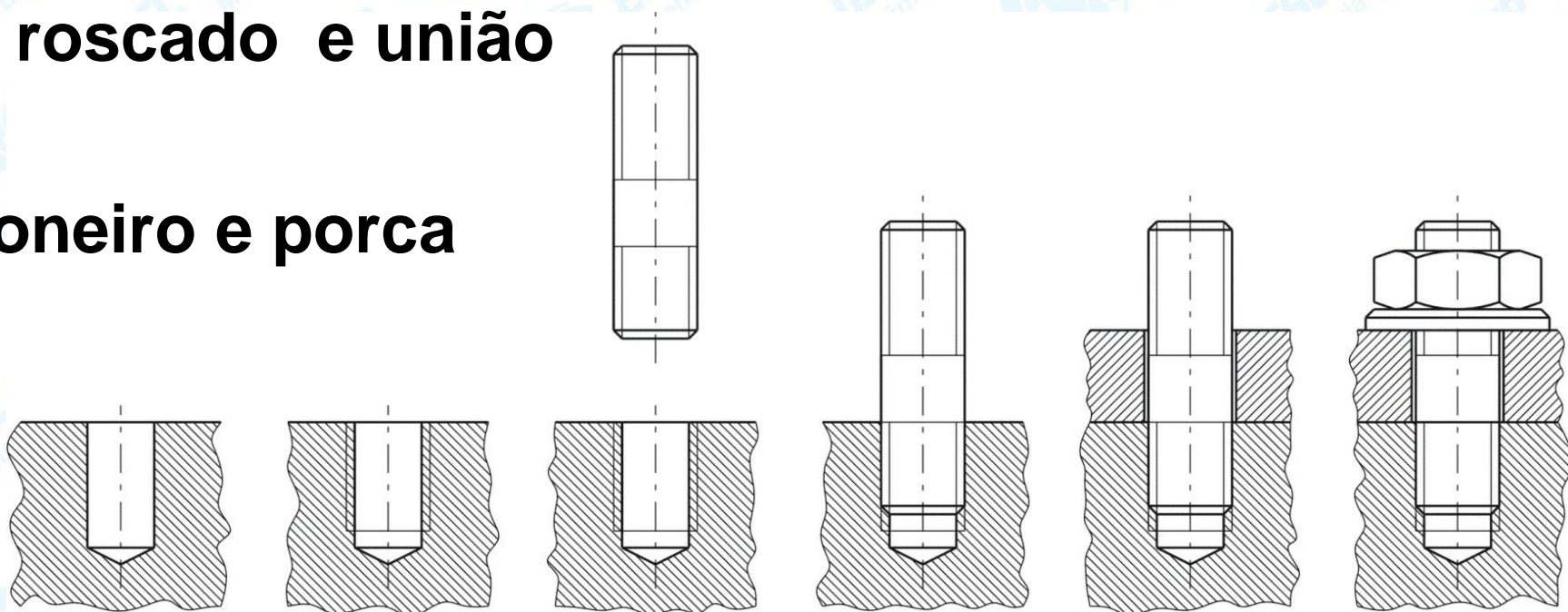

Cotagem e indicação de roscas

Roscas	Símb.	Perfil	Indicação	Leitura
Whitworth normal	-			Rosca Whitworth normal com \varnothing 1" (é dispensável uso do símbolo W)
Whitworth fina	W			Rosca Whitworth fina com \varnothing 1" e 10 filetes por 1" linear de avanço.
Whitworth para cano	RC			Rosca Whitworth para cano com furo de \varnothing 1"
Métrica	M			Rosca métrica normal com \varnothing 16
Métrica fina	M			Rosca métrica fina com \varnothing 60 e passo 4
SAE para automóveis	SAE			Rosca SAE com \varnothing 1"
American National Coarse	NC			Rosca NC com \varnothing 2"
American National Fine	NF			Rosca NF com 1"
Trapezoidal	Tr			Rosca trapezoidal com \varnothing 48 e passo 8
Quadrada	Quad.			Rosca quadrada com \varnothing 30 e passo 6

Acima para roscas com uma entrada à direita.

Para roscas à esquerda ou com mais de uma entrada, deve-se acrescentar a simbologia:

Esquerda

Esq. 2 entr.

Esq. 4 entr.

Tipo de parafusos

De cabeça sextavada

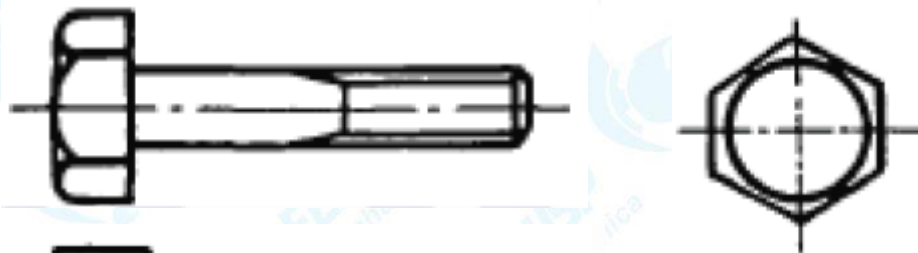

Com sextavado interno



De cabeça quadrada

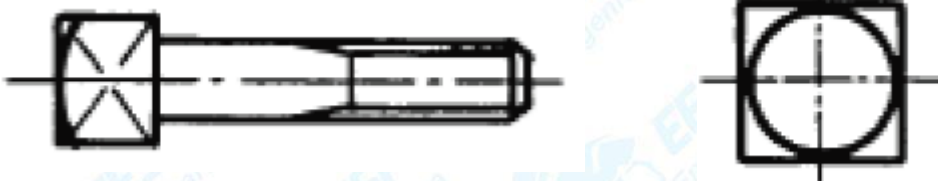

De cabeça triangular

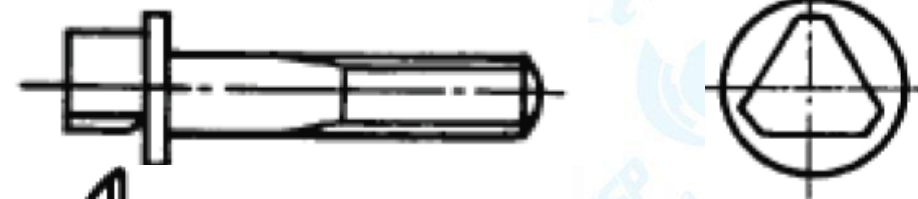

De cabeça arredondada

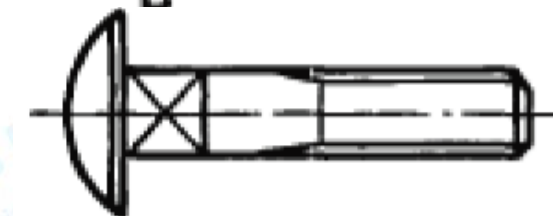

De cabeça escareada



De cabeça retangular



De cabeça com fenda



Cilíndrica



Redonda



Abaulada

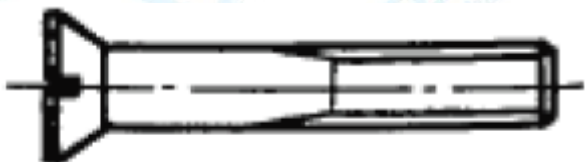

Escareada

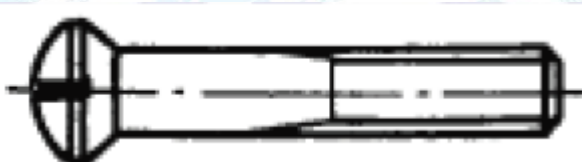

Escareada-abaulada

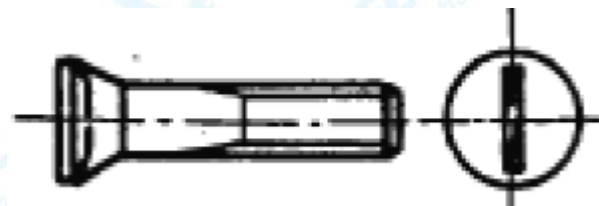

Fenda interna

Prisioneiro



Sem cabeça



fenda



Sextavado interno

Auto atarraxante

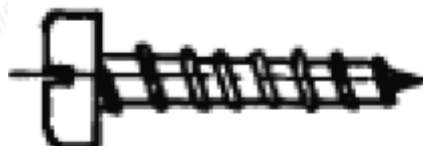
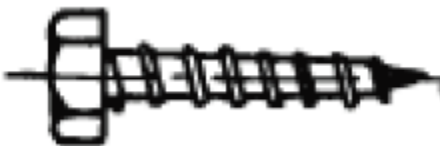

Para madeira

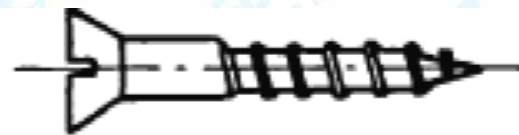
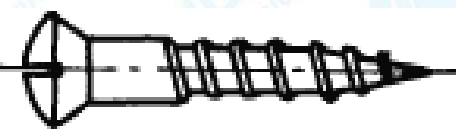

Porcas

Sextavada

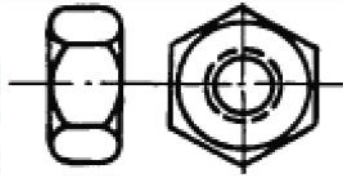

Quadrada



Triangular

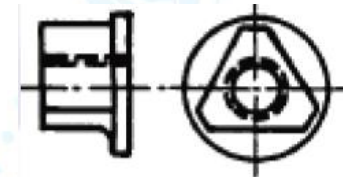

Castelo

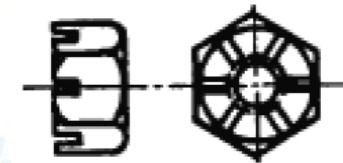

Cegas (calota)

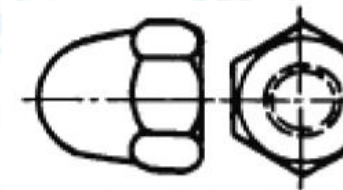

Borboleta

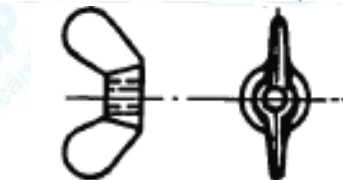

Parafuso com cabeça e porca hexagonais

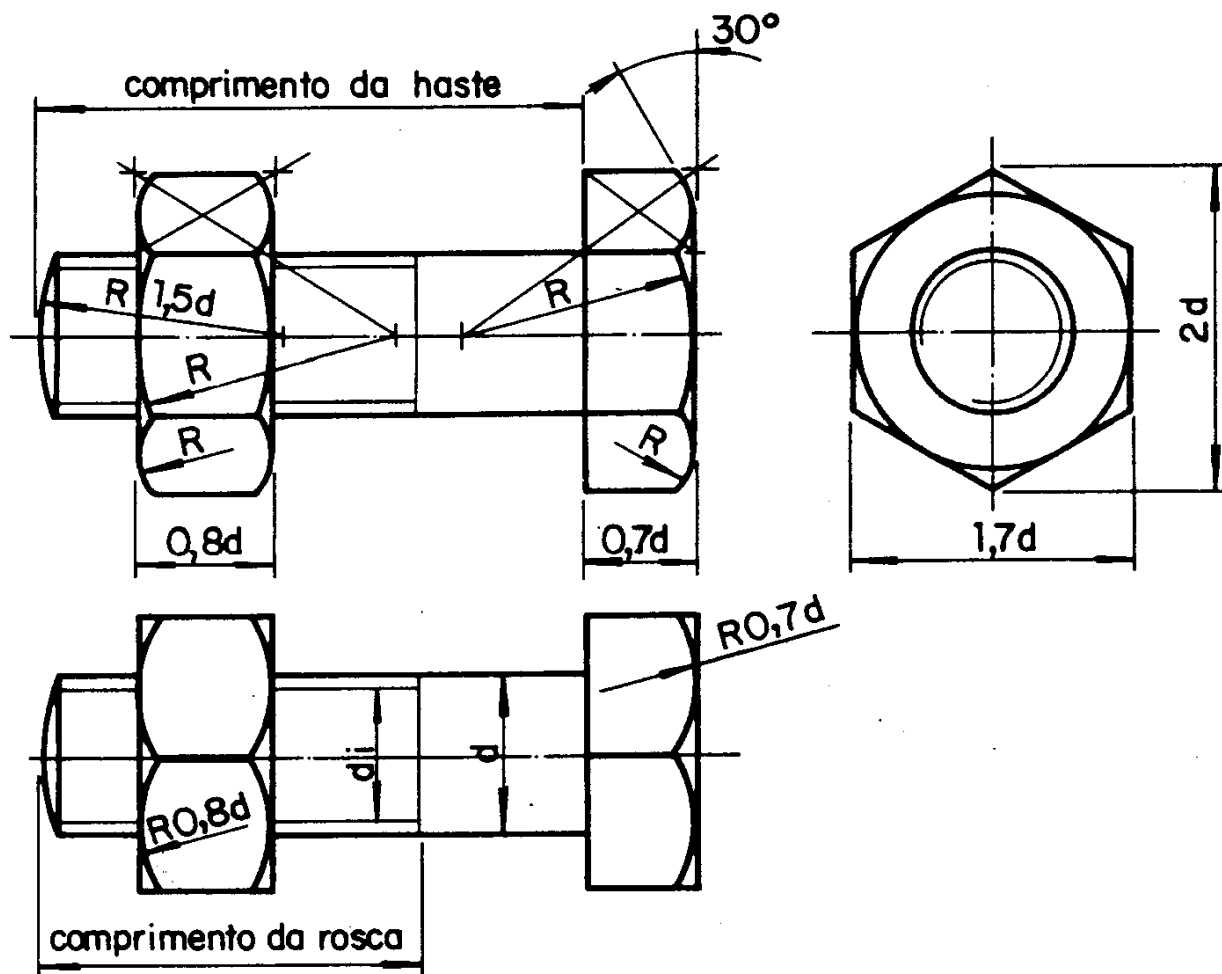

Proporção para desenhar parafusos e porcas



TABELA DE ROSCAS

ROSCA MÉTRICA (M) Perfil triangular - ISO NB 97			ROSCA WHITWORTH Normal				ROSCA WHITWORTH GÁS Para canos (RC) NB 202 - ABNT			
d Diam.	di Núcleo	P Passo	d Poleg.	d mm	di Núcleo	Nº de fios/1"	d Poleg.	d mm	di Núcleo	Nº de fios/1"
4	3,141	0,7	1/8"	3,17	2,36	40	1/8"	9,73	8,57	28
6	4,773	1	5/32"	3,96	2,95	32	1/4"	13,15	11,44	19
8	6,466	1,25	3/16"	4,76	3,40	24	3/8"	16,63	14,95	19
10	8,160	1,5	7/32"	5,55	4,20	20	1/2"	20,95	18,63	14
12	9,833	1,75	1/4"	6,35	4,72	20	5/8"	22,91	20,58	14
14	11,546	2	5/16"	7,93	6,13	18	3/4"	26,44	24,11	14
16	13,546	2	3/8"	9,52	7,49	16	7/8"	30,20	27,87	14
18	14,933	2,5	1/2"	12,70	9,99	12	1"	33,25	30,29	11
20	16,933	2,5	9/16"	14,28	11,57	12	1 1/4"	41,91	38,95	11
22	18,933	2,5	5/8"	15,87	12,91	11	1 1/2"	47,80	44,84	11
24	20,319	3	11/16"	17,46	14,50	11	1 3/4"	53,74	50,79	11
30	25,706	3,5	3/4"	19,05	16,79	10	2"	59,61	56,65	11
36	31,093	4	13/16"	20,63	17,38	10	2 1/4"	65,71	62,75	11
42	36,479	4,5	7/8"	22,22	18,61	9	2 1/2"	75,18	72,23	11
48	41,866	5	15/16"	23,81	20,19	9	2 3/4"	81,53	78,58	11
56	49,252	5,5	1"	25,40	21,33	8	3"	87,88	84,93	11
60	53,252	5,5	1 1/8"	28,57	23,92	7	3 1/4"	93,98	91,02	11
64	56,639	6	1 1/4"	31,75	27,10	7	3 1/2"	100,33	97,37	11

Parafusos de cabeça com fenda

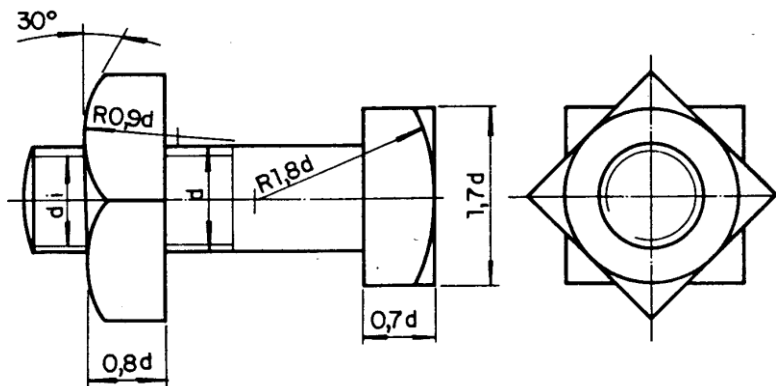
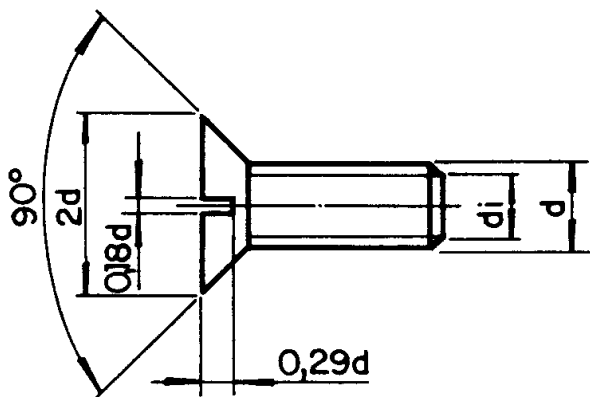

escareada chata

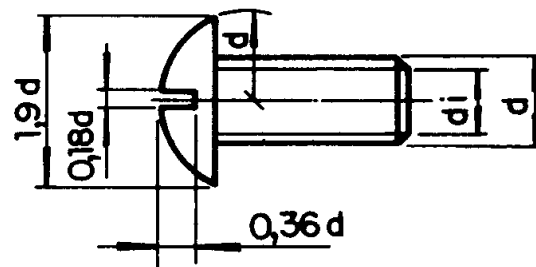

redonda

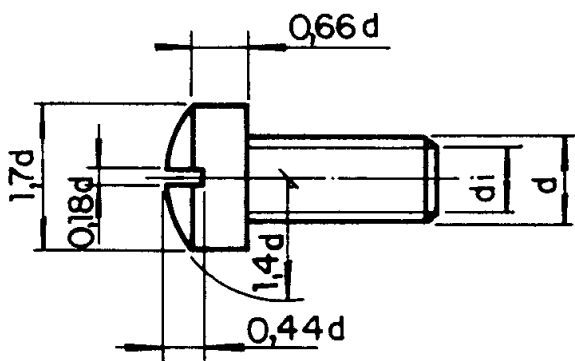

cilíndrica boleada

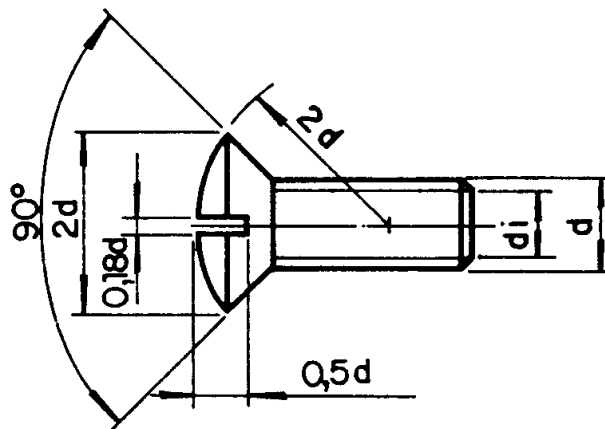

escareada boleada

Parafuso com sextavado interno

Parafuso prisioneiro

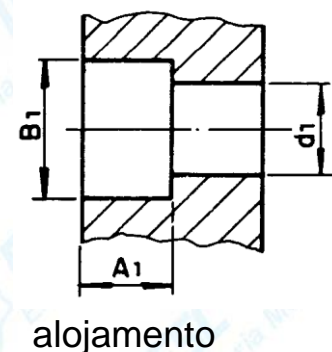
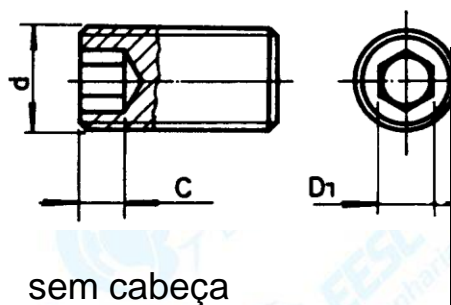
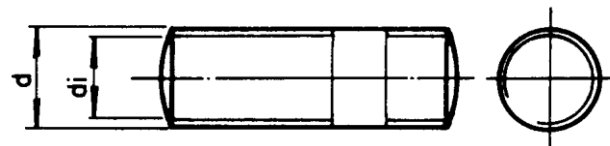
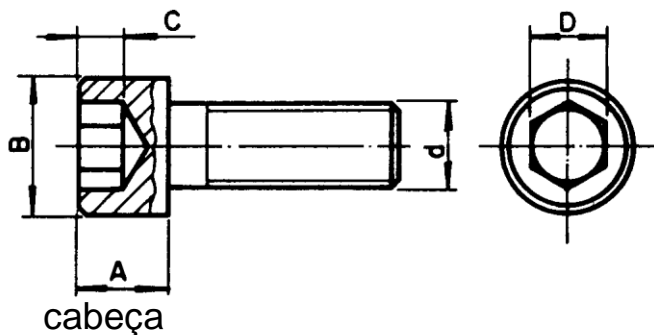

	d	A	B	A ₁	B ₁	d ₁	C	D	D ₁	Passo (gross o)	Broca furo rosca
M3	3	2,86	5,38	3	5,7	3,3	1,3	2,5	1,5	0,5	2,5
M4	4	3,85	6,85	4	7,4	4,3	2	3	2	0,7	3,5
M5	5	4,85	8,35	5	8,9	5,3	2,5	4	2,5	0,8	4,2
M6	6	5,85	9,85	6	10,4	6,4	3	5	3	1	5
M8	8	7,82	12,82	8	13,5	8,4	4	6	4	1,25	6,7
M10	10	9,8	15,82	10	16,5	10,5	5	8	5	1,5	8,5
M12	12	11,77	17,82	12	19	13	6	10	6	1,75	10,2
M14	14	13,76	20,79	14	22	15	7	12	6	2	11,9
M16	16	15,75	23,79	16	25	17	8	14	8	2	14
M20	20	19,70	29,79	20	31	21	10	17	10	2,5	17,5

ISO 4762/DIN 912

Porca borboleta

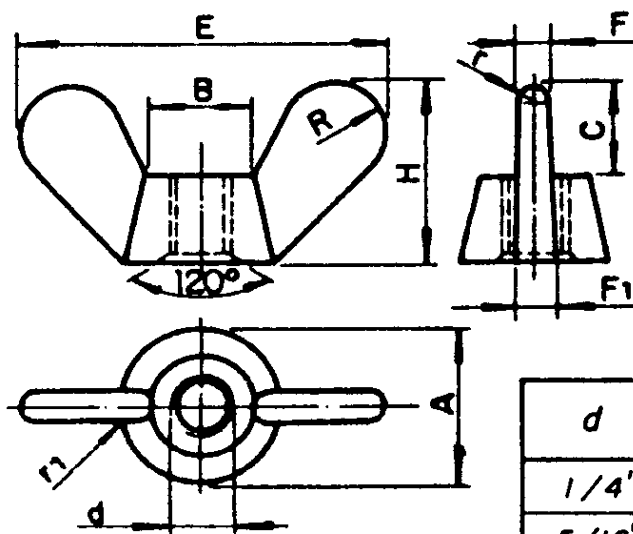

d	A	B	C	E	F	F_1	H	R	r	r_1
1/4"	12	10	8	32	2,5	3	16	3	1,25	3
5/16"	16	12	10	40	3	4	20	6	1,4	4
3/8"	20	16	12	50	4	5	25	8	2	5
7/16"	23	19	14	64	5	6	32	10	2,5	6
1/2"	23	19	14	64	5	6	32	10	2,5	6
5/8"	28	22	16	72	6	7	36	11	3	7
3/4"	36	28	20	90	7	9	40	14	3,5	8
7/8"	40	32	22	100	8	10	50	16	4	9
1"	45	36	24	112	9	11	56	18	4,5	10

Arruela Lisa



Arruela de pressão



Arruela com denteado

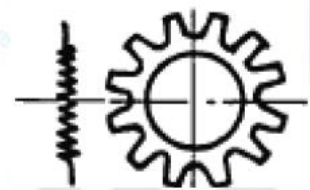

Arruela de travamento



Arruela

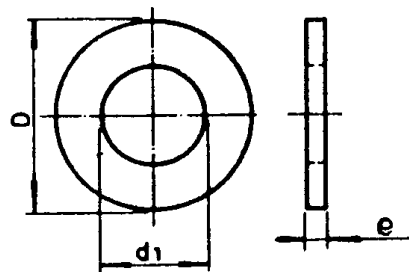

plana

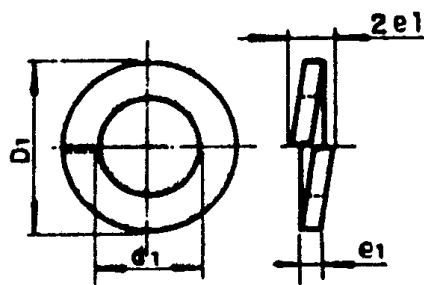

de pressão

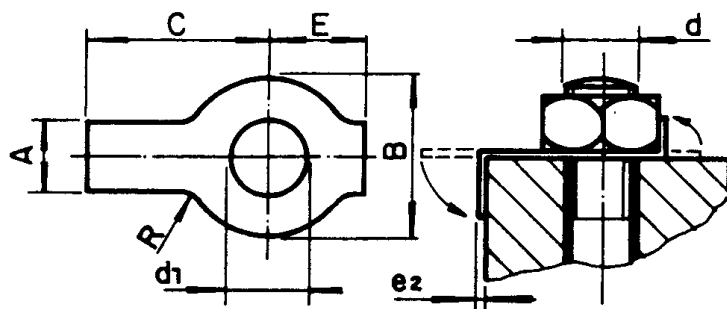

de segurança

d	d_1	D	e	D_1	e_1	e_2	A	B	C	E	R
3	3,5	8	0,8	5,5	0,8	0,3	4	8	11	5	2
4	4,5	10	0,8	7	0,9	0,4	5	10	14	6	2,5
5	5,5	12	1	8,5	1,2	0,5	6	12	16	7	2,5
6	6,5	14	1,2	11	1,6	0,5	7	15	18	8	3
8	8,5	18	1,5	14	2	0,75	8	18	20	11	3
10	11	22	2	17	2,2	0,75	10	23	22	14	4
12	13	27	2,5	20	2,5	1	12	26	24	17	4
14	15	30	2,5	23	3	1	14	30	28	19	5
16	17	32	3	26	3,5	1	15	34	32	21	5
18	19	36	3	29	3,5	1	16	36	36	23	6
20	21	40	3	32	4	1	18	40	40	26	6
22	23,5	45	3	35	4	1	20	42	45	28	8
24	25,5	50	4	38,5	5	1	22	45	48	31	8
27	28,5	55	4	42	5	1	24	48	55	34	10
30	32	60	4	46,5	6	1,5	26	55	60	38	10

Rebites

Os rebites são elementos de fixação permanente, fabricados com materiais resistentes e dúcteis como o aço, o latão ou o alumínio. São empregados nas uniões de chapas e perfis laminados, principalmente em estruturas metálicas e construções de reservatórios, caldeiras, máquinas e navios.

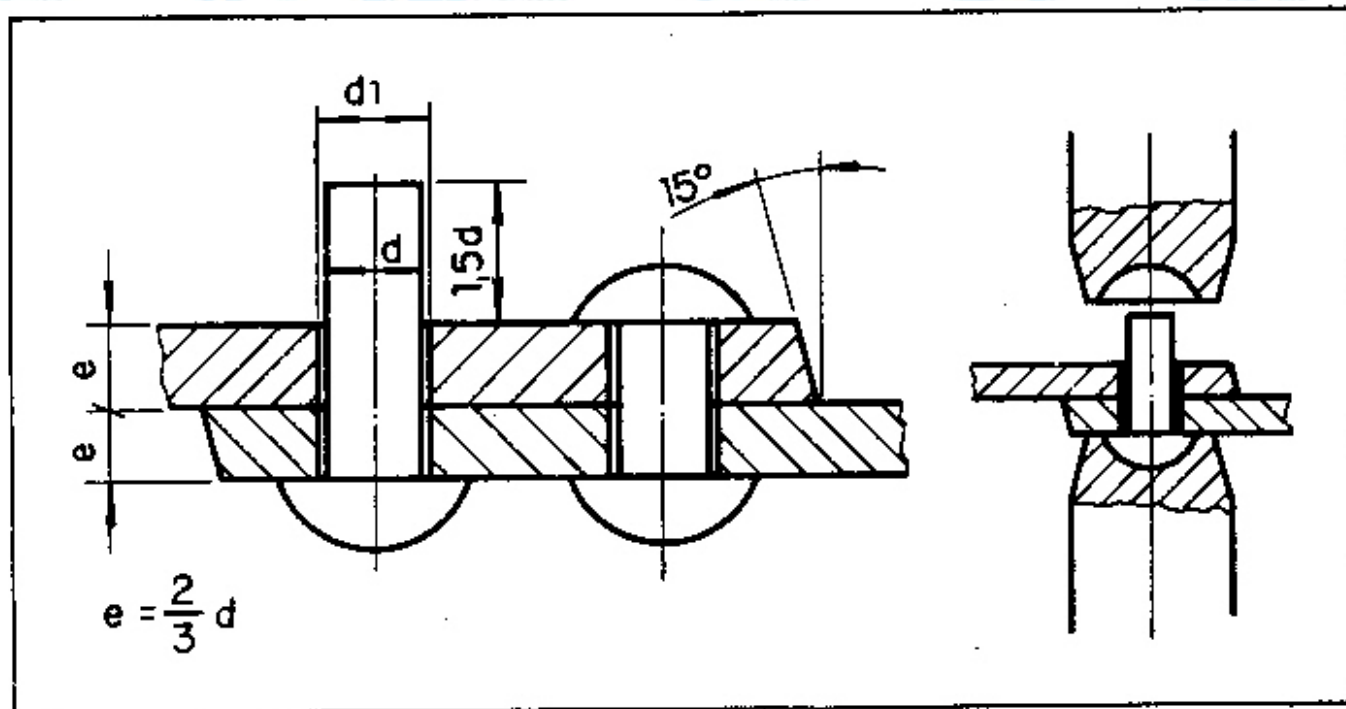

Rebite: tipos e proporções

Os rebites têm cabeças e corpo e são classificados como:

- cabeça redonda;
- cabeça escareada;
- cabeça cilíndrica;
- cabeça boleada.

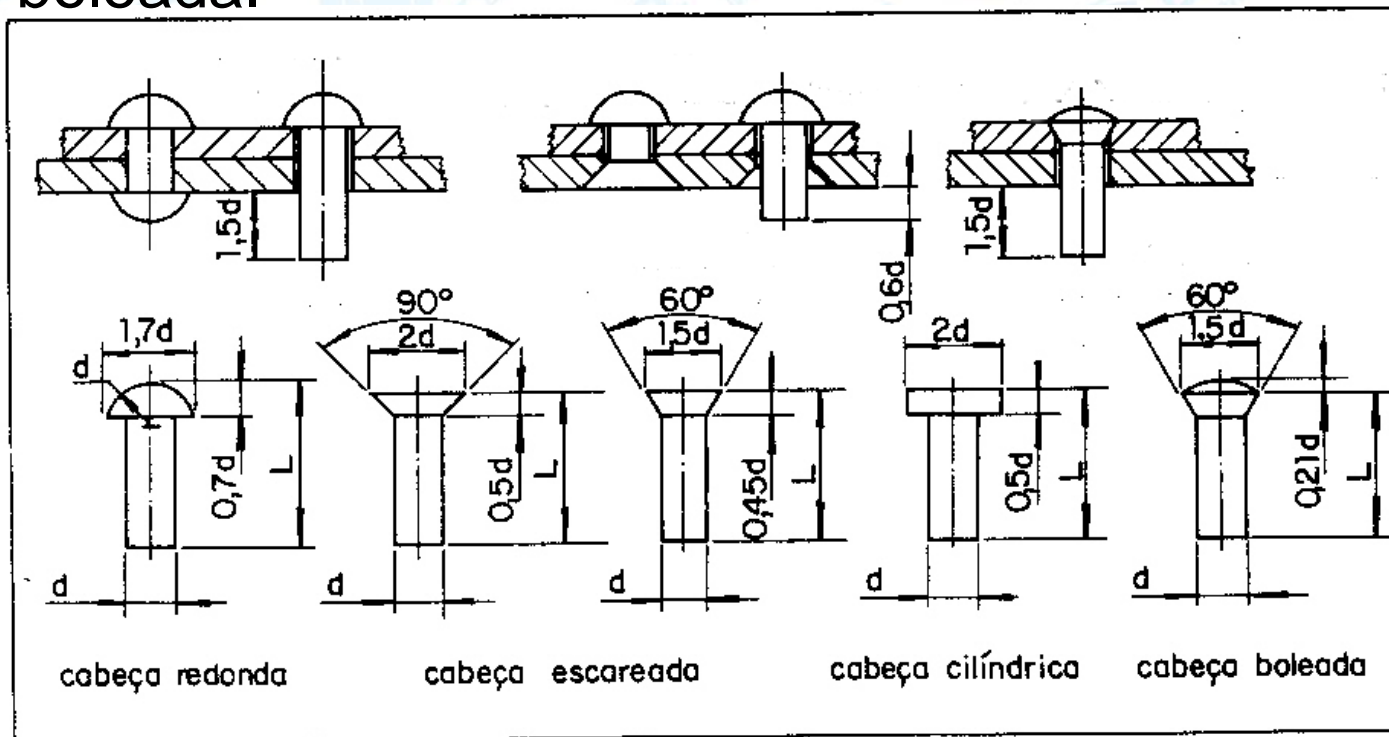

Rebites - Costuras e Proporções

As costuras dos rebites classificam-se em:

- a) simples;
- b) dupla;
- c) em zigue-zague.

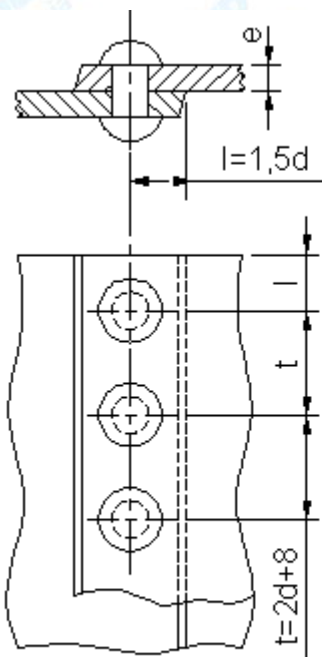
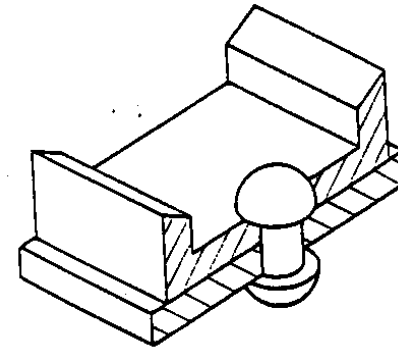

Costura simples

a)

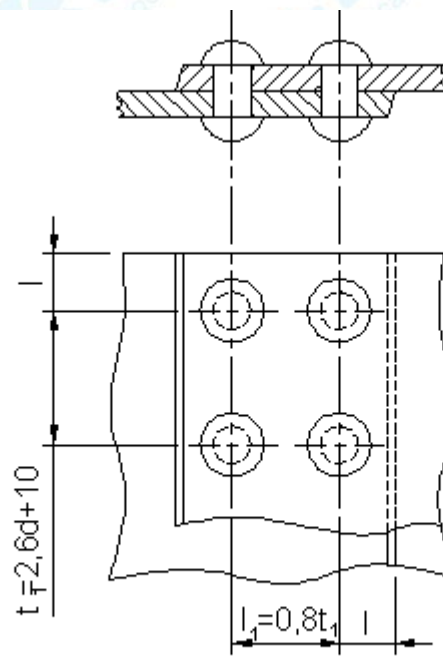

Costura dupla

b)

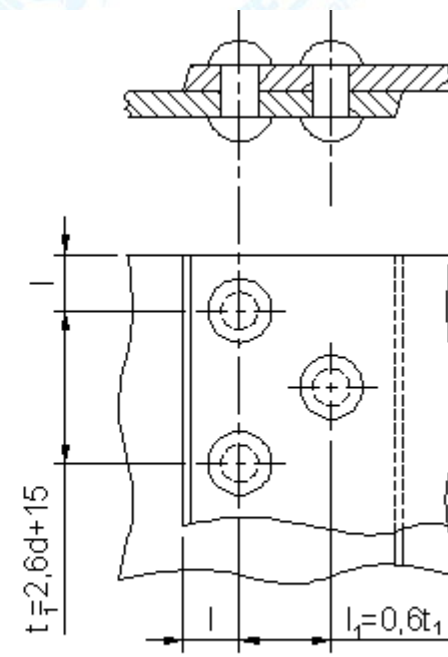

Costura em zigue-zague

c)

Soldas

São elementos de fixação ou de revestimento de materiais, obtidos por aplicação de calor, assistido ou não por pressão.

A representação em desenho técnico da soldagem é feita através de símbolos e deve fornecer, sem equívoco, as especificações sobre o projeto da solda.

Em vistas projetivas, sem corte, os cordões não são desenhados e sim representados e compreende:

- símbolo elementar;
- símbolos suplementares;
- cotagem;
- Informações complementares;
- especificações de manufatura.

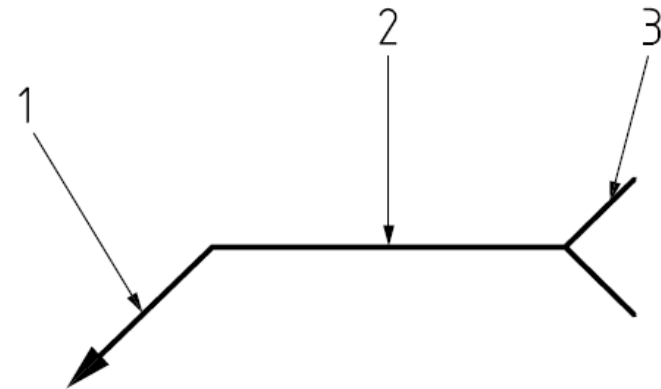

- 1 – linha com seta indicativa;
- 2 – linha de referência;
- 3 – cauda.

Seta indicadora da solda - Simbologia

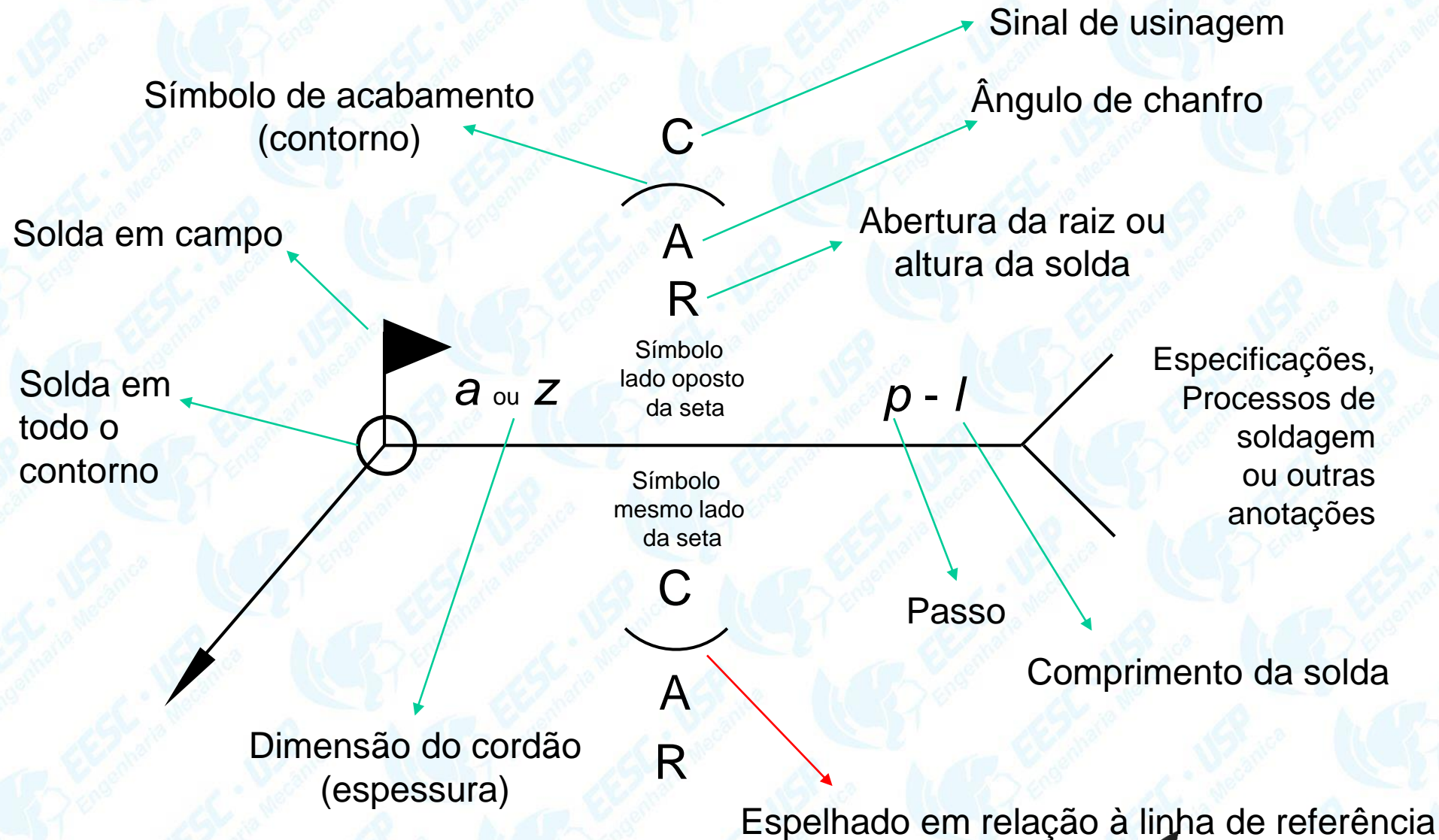

Símbolos complementares

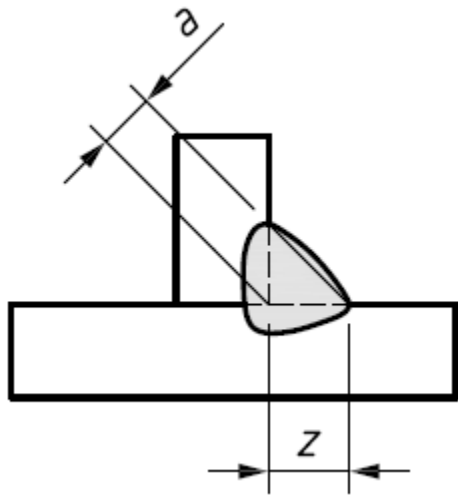

Solda em todo o contorno



Solda realizada em campo

Dimensões do cordão, a ou z seguido da medida em mm

R, **raiz**, representa o afastamento entre as partes

A, **ângulo**, representa o ângulo do chanfro

Exemplo

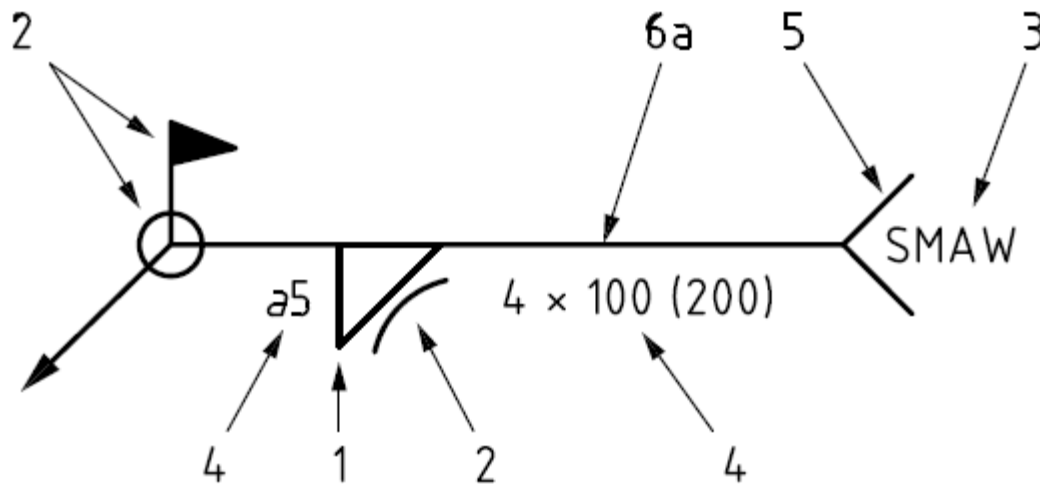







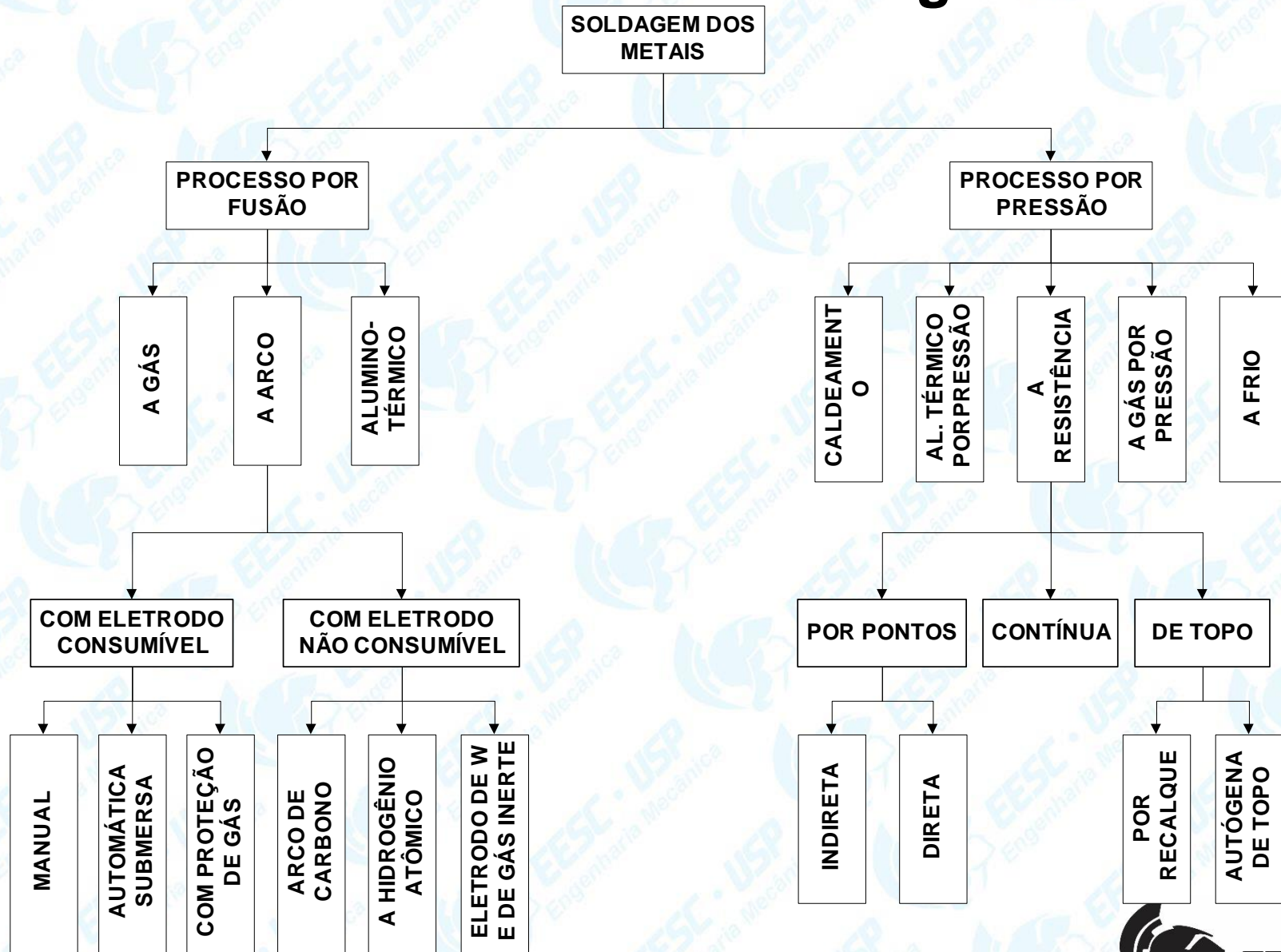



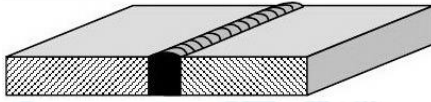

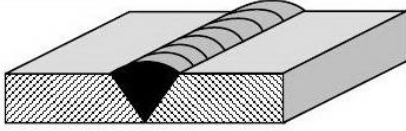

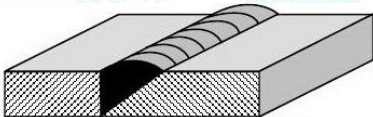
- 1 – Símbolo elementar;
- 2 – Símbolos suplementares: cordão de acabamento côncavo, em campo e de contorno;
- 3 – informação complementar: **SMAW** (Shielded Metal Arc Welding) → Eletrodo Revestido.
- 4 – dimensões: nominal de 5 mm de garganta, composta por 4 elementos de 100 mm de comprimento espaçados em 200mm;
- 5 – cauda
- 6a- linha de referência

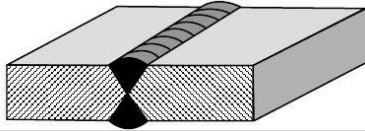
ISO 2553:2013(E)

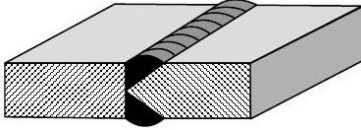
Processos convencionais de soldagem

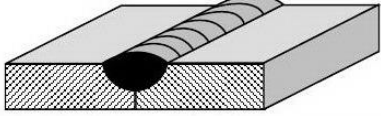

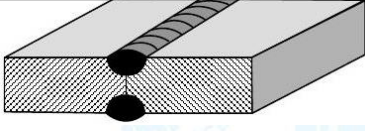
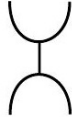
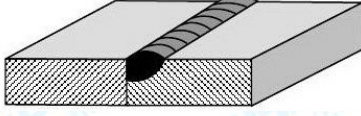

Tipos e Simbologia de uniões em topo

Descrição da União	Ilustração	Símbolo
Reta		
em V		
em meio V		
em duplo V		
em meio duplo V		
em U		
em duplo U		
em meio U ou em J		

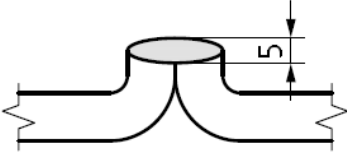
Tipos e Simbologia de uniões em topo

Descrição da União	Ilustração	Símbolo
em Y		
em meio Y		
em Y dupla		
em meio Y dupla		
Com flange		

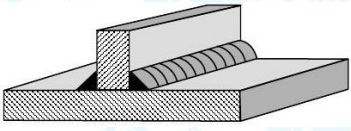
Tipos e Simbologia de uniões

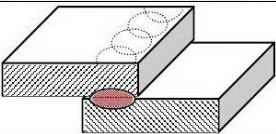

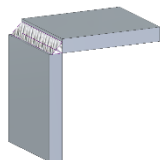

Descrição da União	Ilustração	Símbolo
em ângulo ou “T” unilateral		
em ângulo ou “T” bilateral		
em ângulo ou “T” bilateral, bi chanfrado		
sobreposta		
sobreposta por pontos		
sobreposta por linha contínua ou costura		

de centro

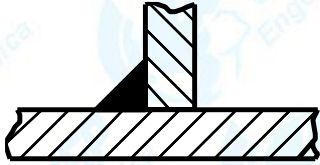

de canto

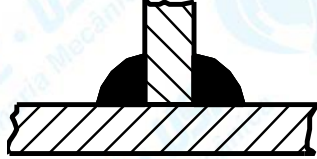
Quanto ao acabamento

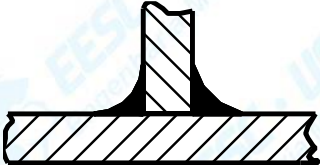
Tipo	Símbolo	Exemplo	
lisa	—		
convexa			
côncava			

Exemplos: Simbologia de uniões em topo

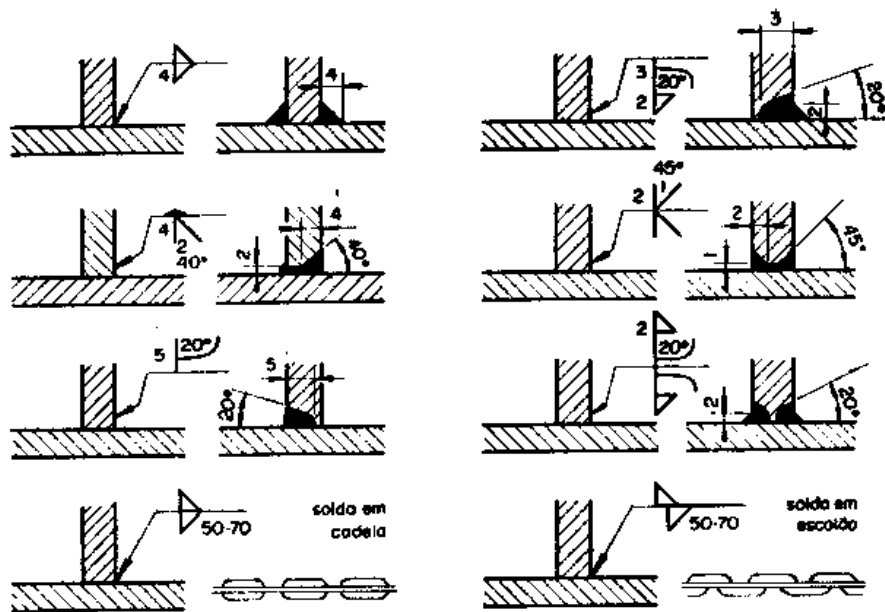
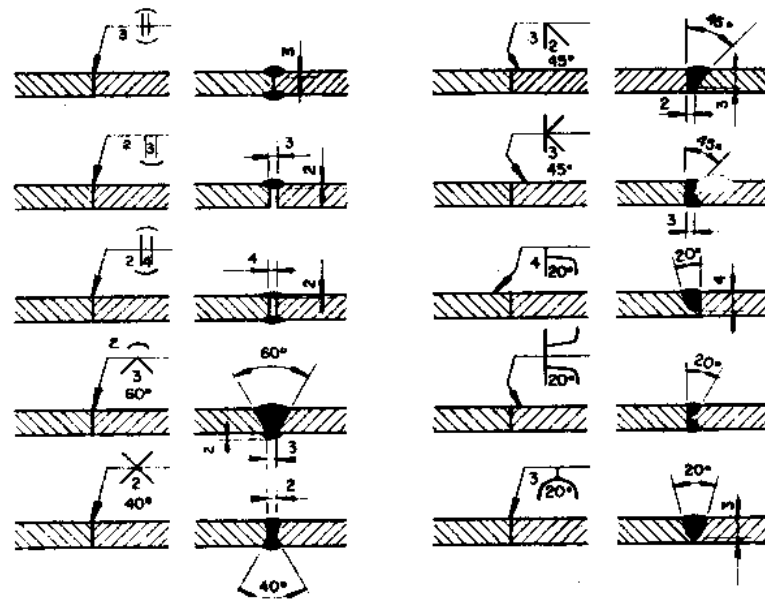

Simbologia de uniões em T

Fonte: Desenhista de Máquinas – Escola pro-tec (1983)

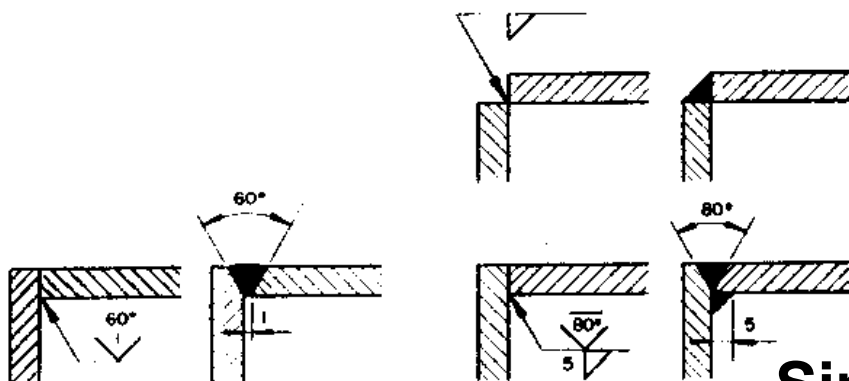

Simbologia de uniões em ângulo

Simbologia de uniões em aresta

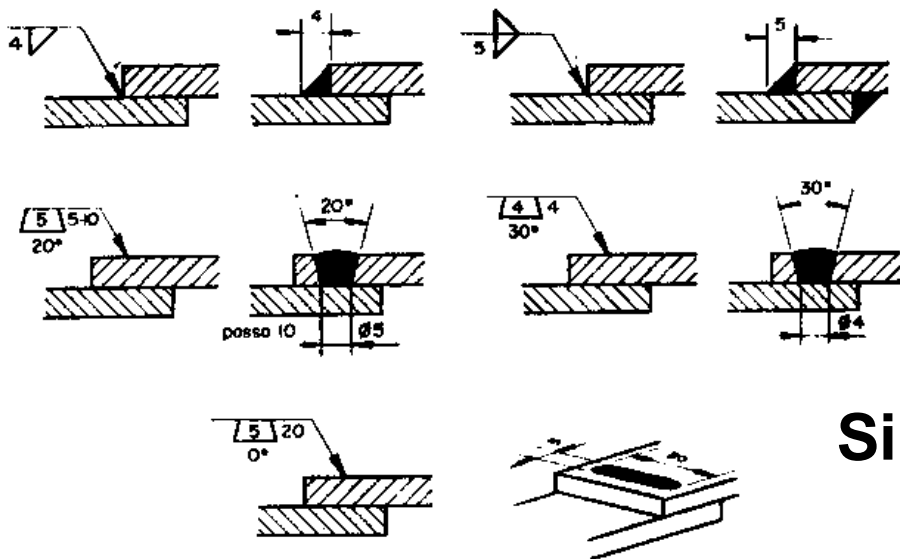
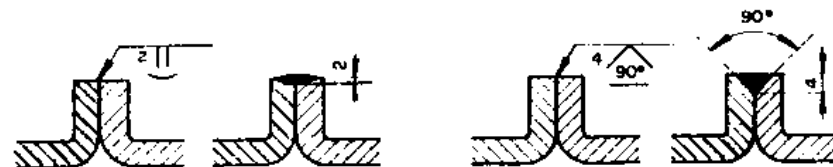

Simbologia de uniões superpostas

Fonte: desenhista de máquinas – escola pro-tec (1983)

Referências

- NBR 5875, Parafusos, porcas e acessórios – terminologia, 2011.
- NBR 5876, Roscas – terminologia, 2011.
- DIN EN ISO 2553 - Welding and allied processes — Symbolic representation on drawings— Welded joints: 2017

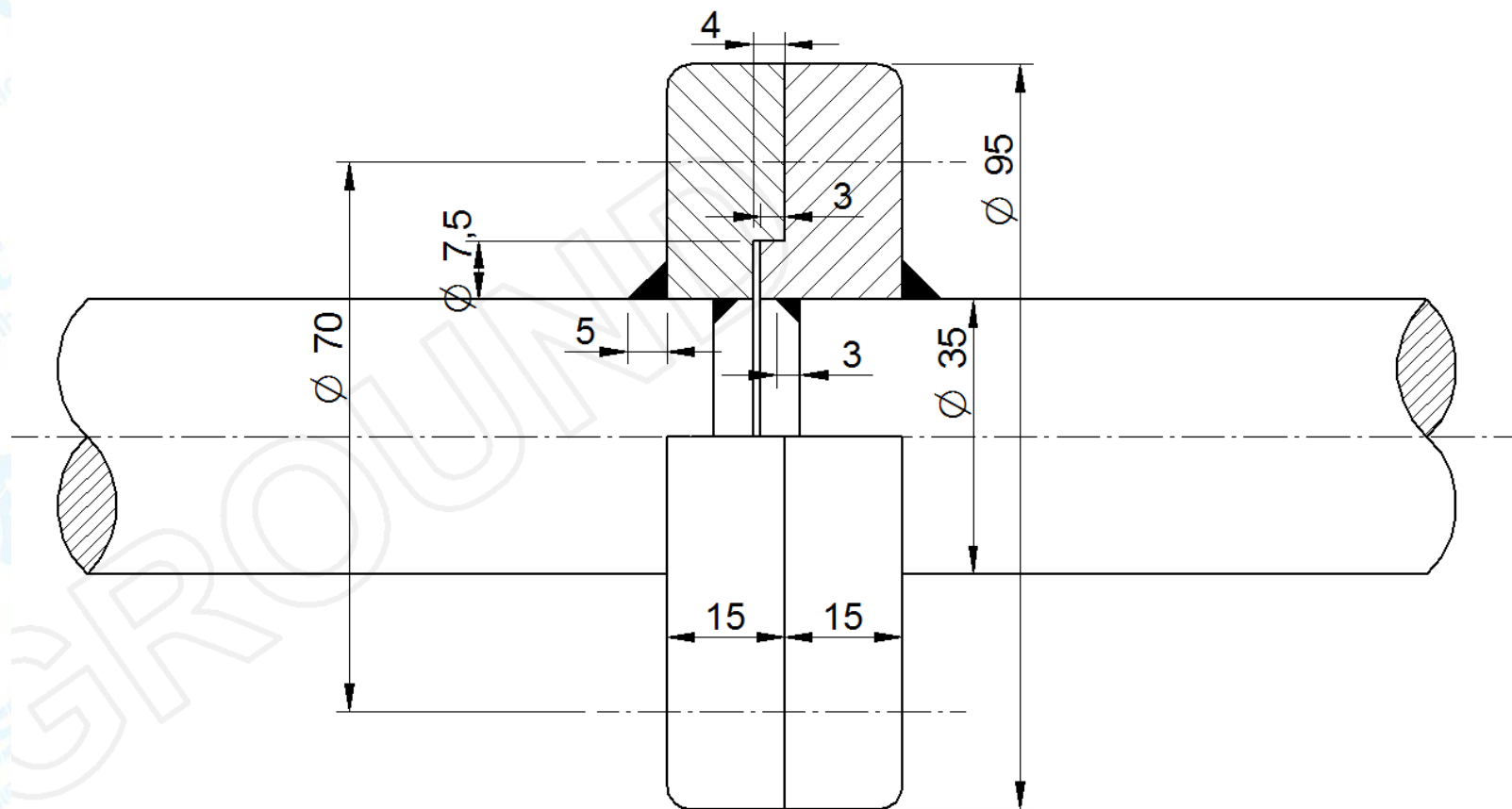

Exercício 1 – Represente a fixação da flange (esquerda) utilizando parafuso M8 (allen) no diâmetro de 70mm com a cabeça embutida, arruela e porca sextavada. Especifique as simbologia da solda do eixo na flange.
 $d=35\text{mm}$; $k\varnothing=70\text{mm}$; $D1=50\text{mm}$; $D_{\text{max}}=95\text{mm}$

Gabarito

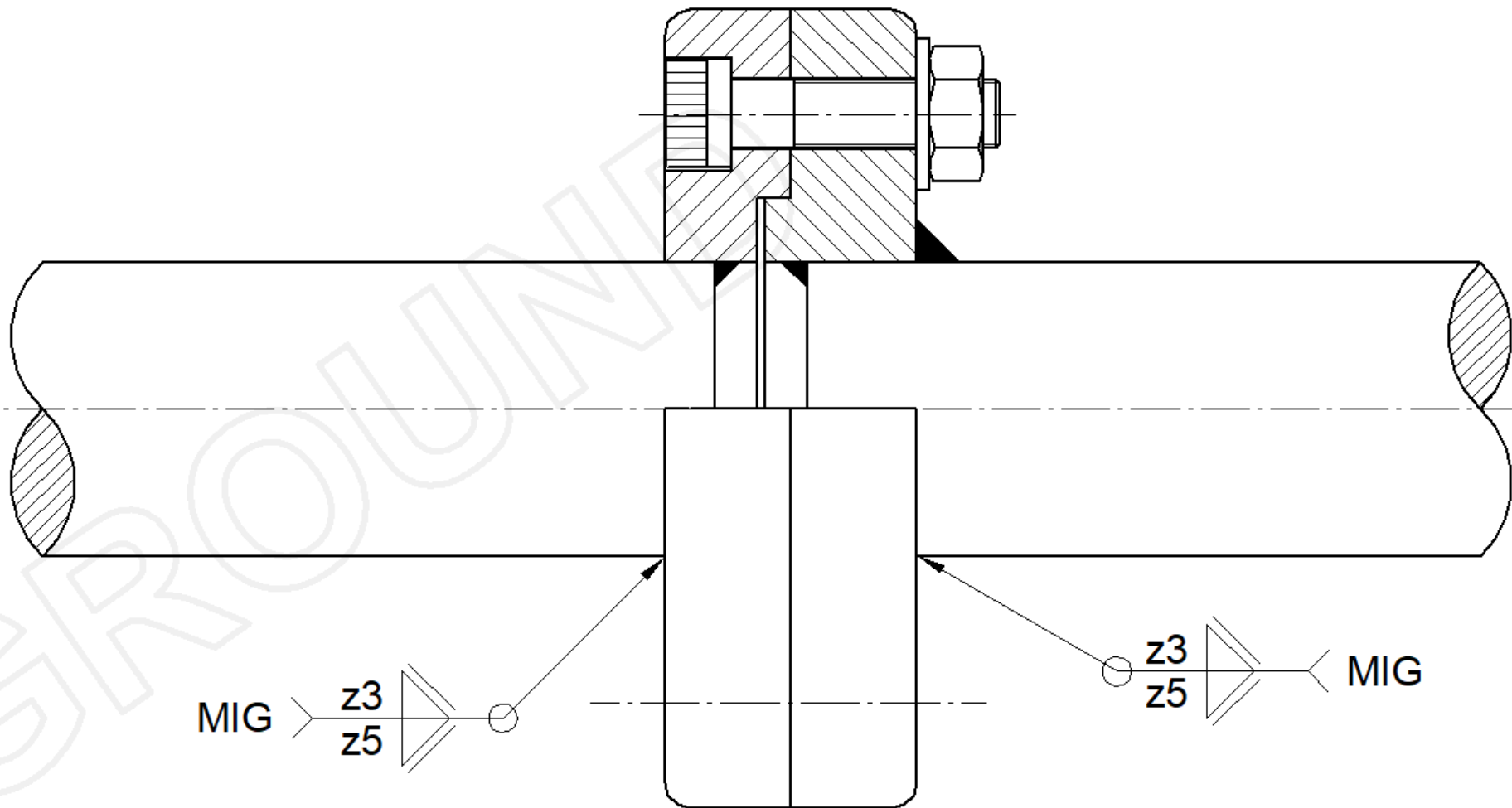

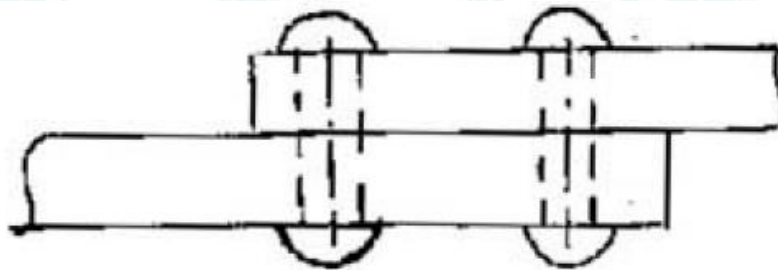

* Considere: $d = 10 \text{ mm}$

Exercício 2 – Desenhar vista superior:

- a) Para 4 rebites com costura dupla;
- b) Para 5 rebites com costura zigue-zague.