

FORMAÇÃO DE CAVACOS

SEP0279 – PORCESSAMENTO DE MATERIAIS II - USINAGEM DOS METAIS

AULA-5: Formação de Cavacos

Reginaldo T. Coelho
rtcoelho@sc.usp.br

FORMAÇÃO DE CAVACOS

Formação de cavacos



FORMAÇÃO DE CAVACOS

Formação de cavacos

P

Steel



FORMAÇÃO DE CAVACOS

Formação de cavacos

M

Stainless steel



FORMAÇÃO DE CAVACOS

Formação de cavacos

K

Cast iron

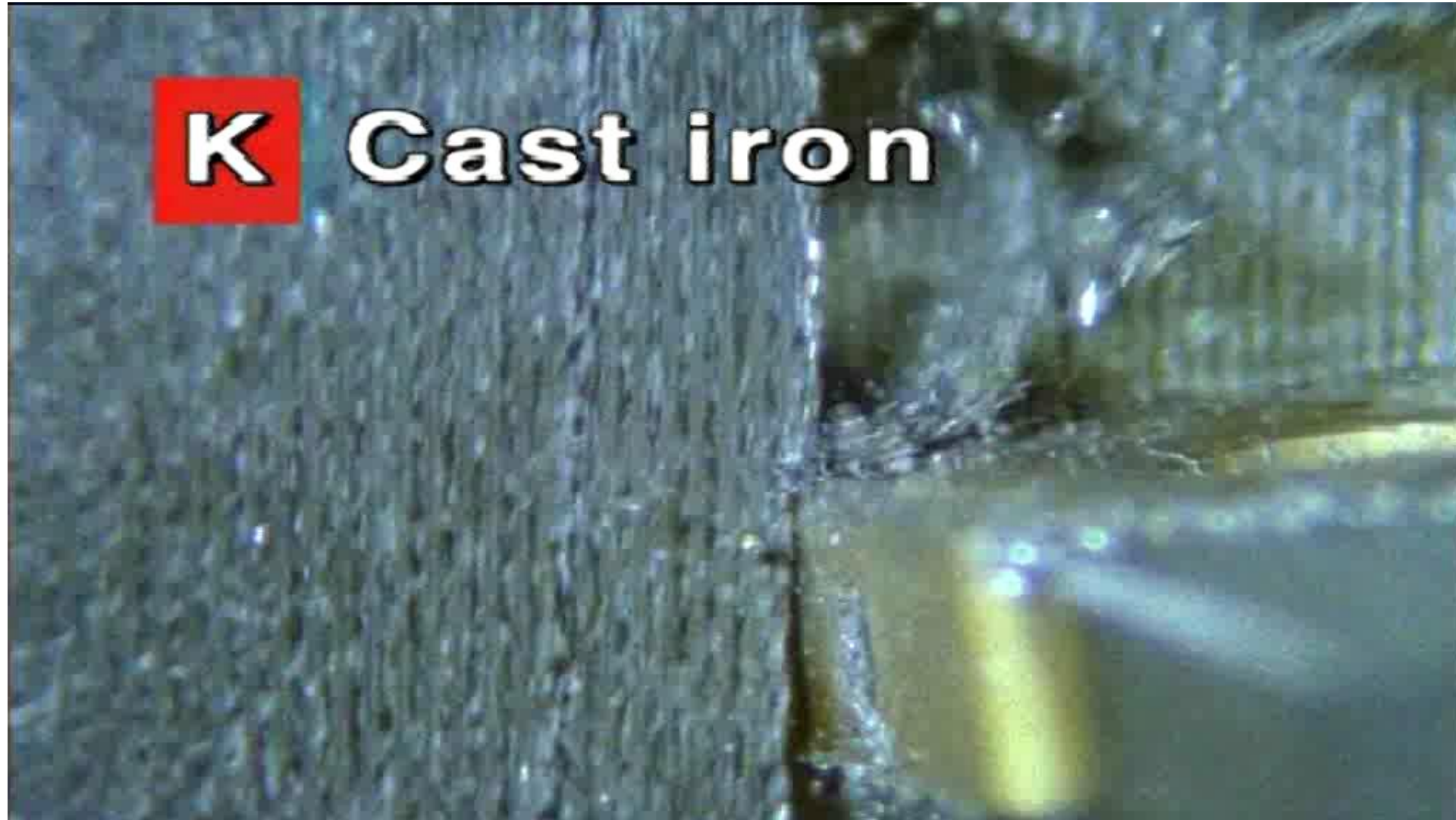

FORMAÇÃO DE CAVACOS

Formação do cavaco

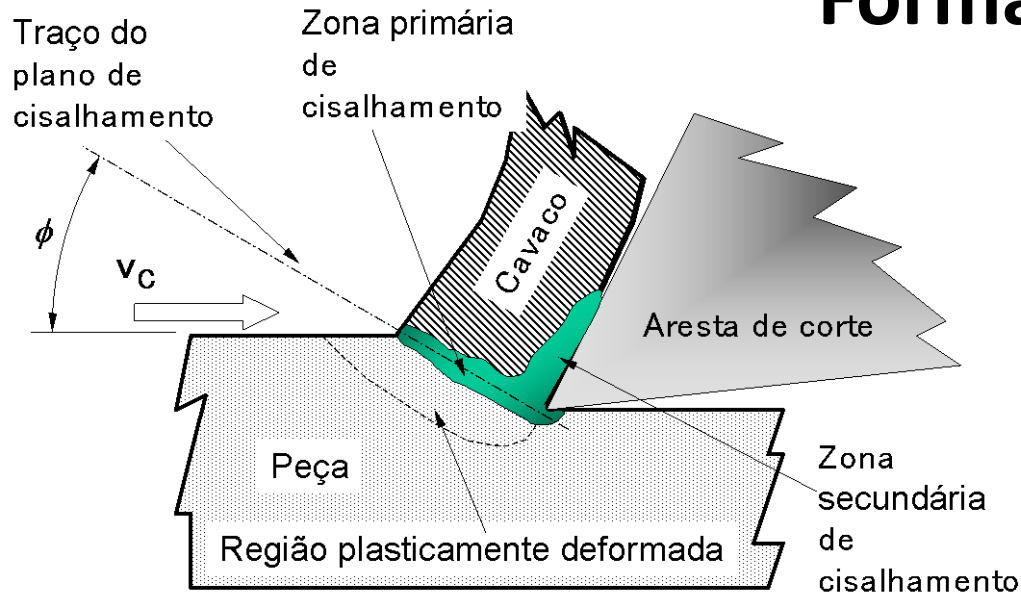

- 1) Recalque inicial.
- 2) Deformação e ruptura
- 3) Deslizamento das lamelas
- 4) Saída do cavaco

FORMAÇÃO DE CAVACOS

Modelo teórico de formação do cavaco

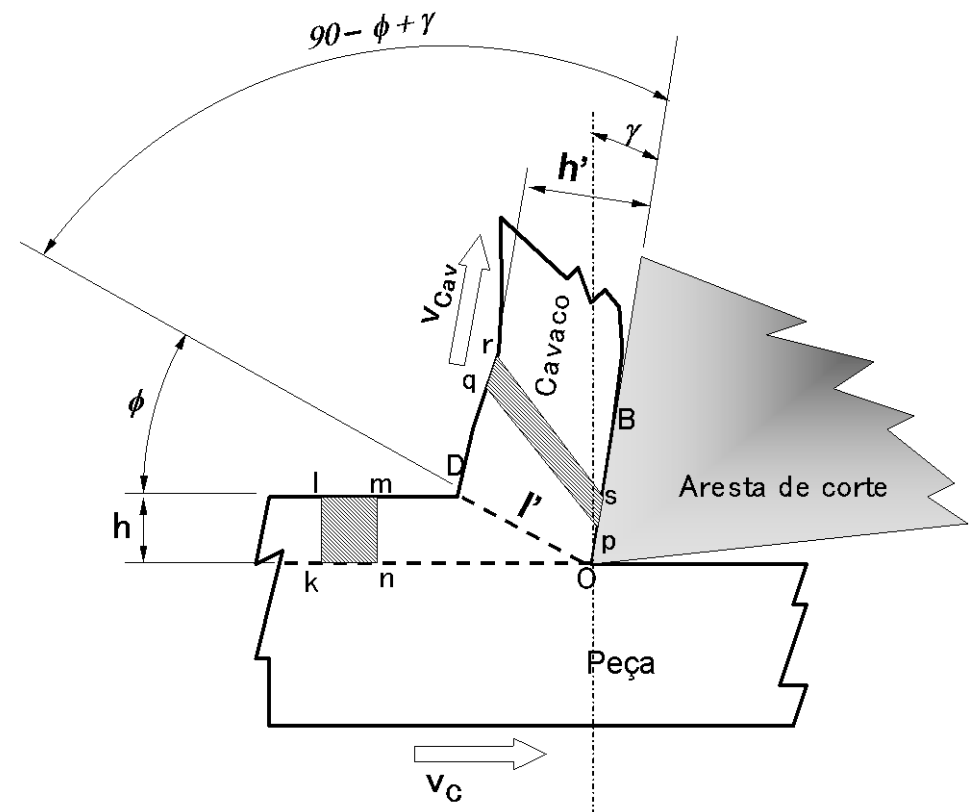
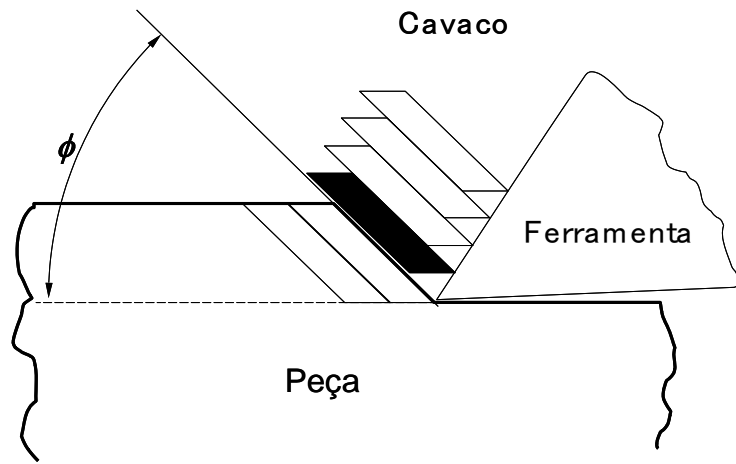

FORMAÇÃO DE CAVACOS

CORTE ORTOGONAL E OBLÍQUO

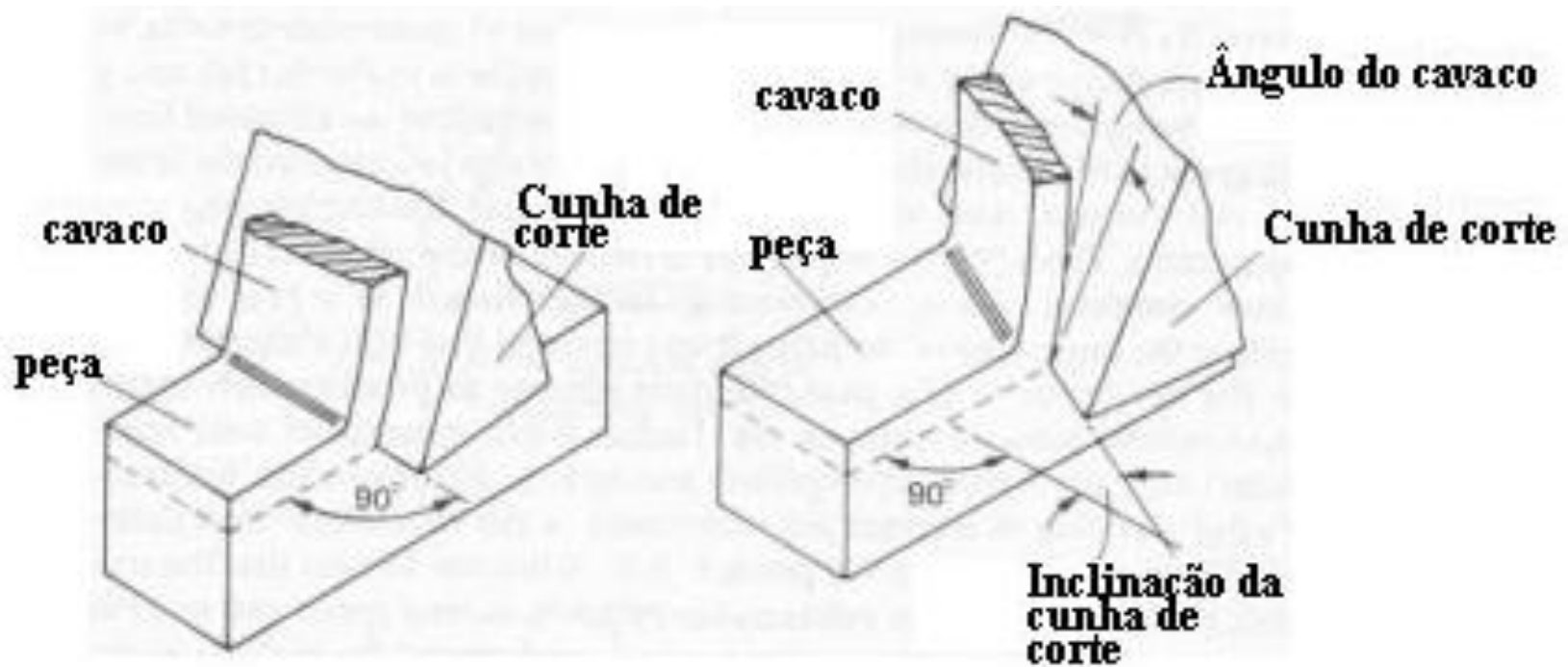

FORMAÇÃO DE CAVACOS

Corte ortogonal

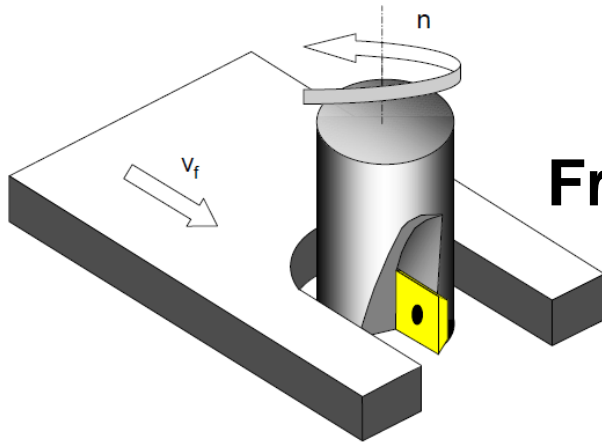

Fresamento

Modelo Teórico

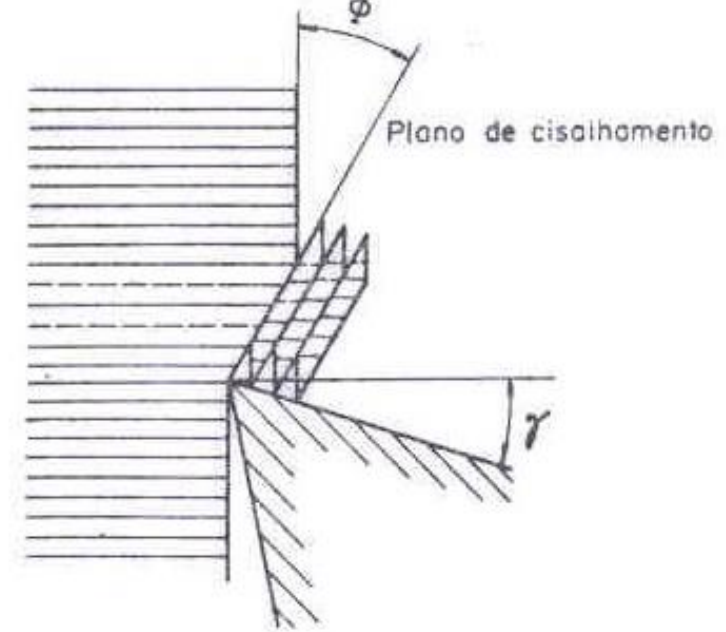

Torneamento

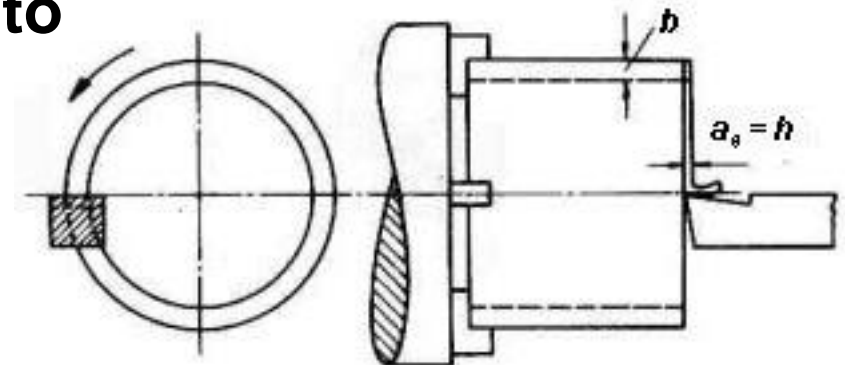
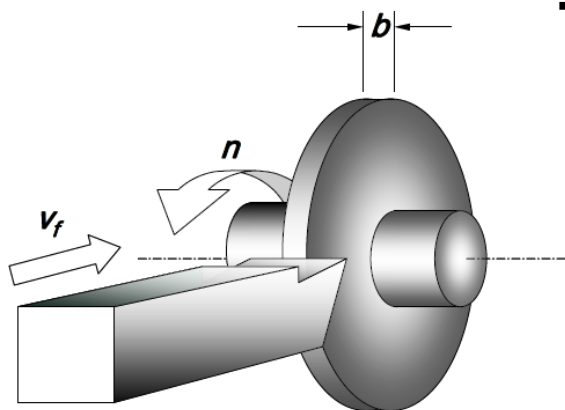

FORMAÇÃO DE CAVACOS

Modelo Teórico – Relações geométricas

$$\operatorname{tg} \phi = \frac{\cos \gamma}{R_c - \operatorname{sen} \gamma}$$

$$\operatorname{sen} \phi = \frac{h}{l'}$$

$$\operatorname{sen}(90 - \phi + \gamma) = \frac{h'}{l'}$$

$$R_c = \frac{h'}{h}$$

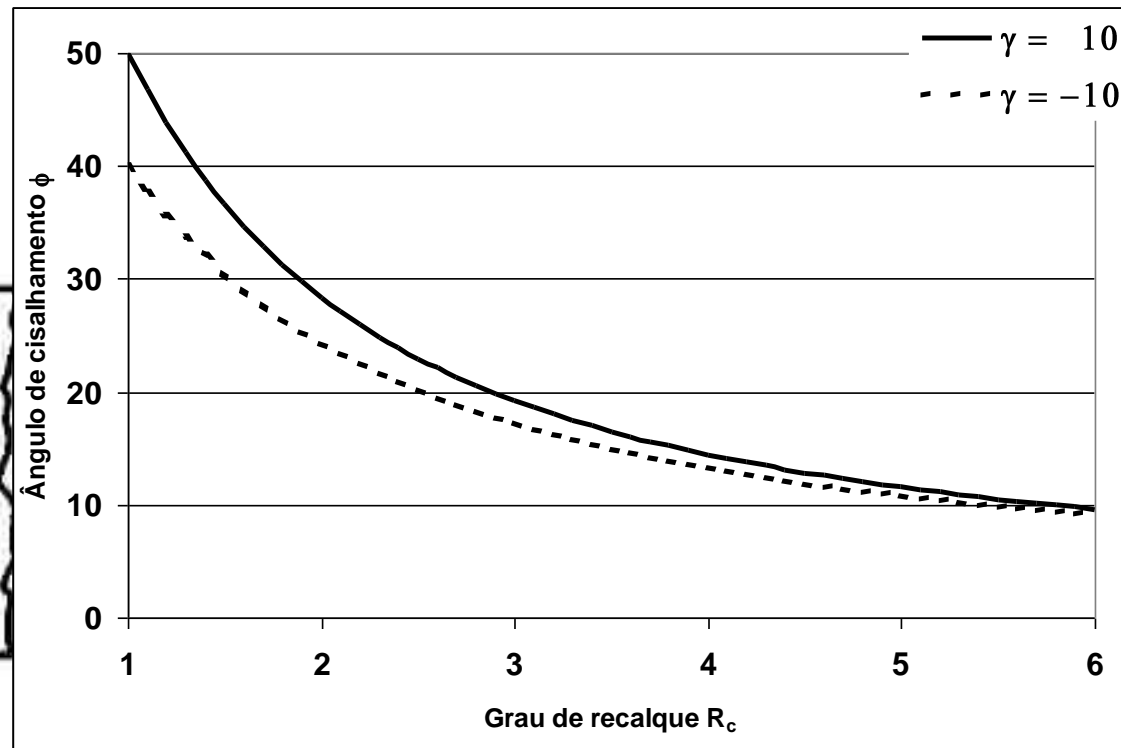
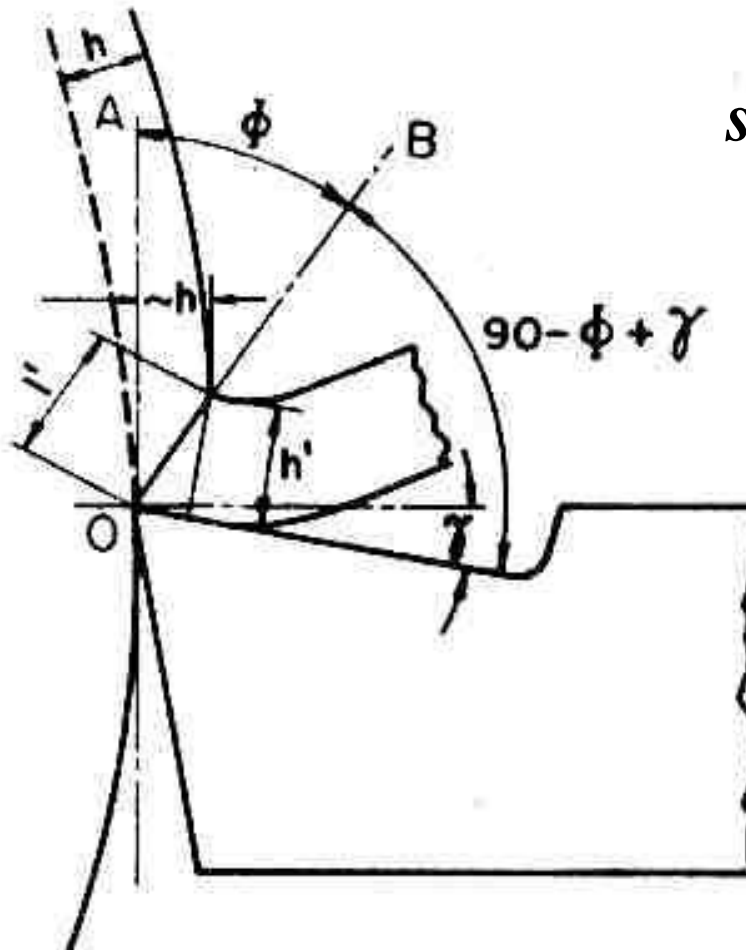

FORMAÇÃO DE CAVACOS

Modelo Teórico – Relações de Velocidade

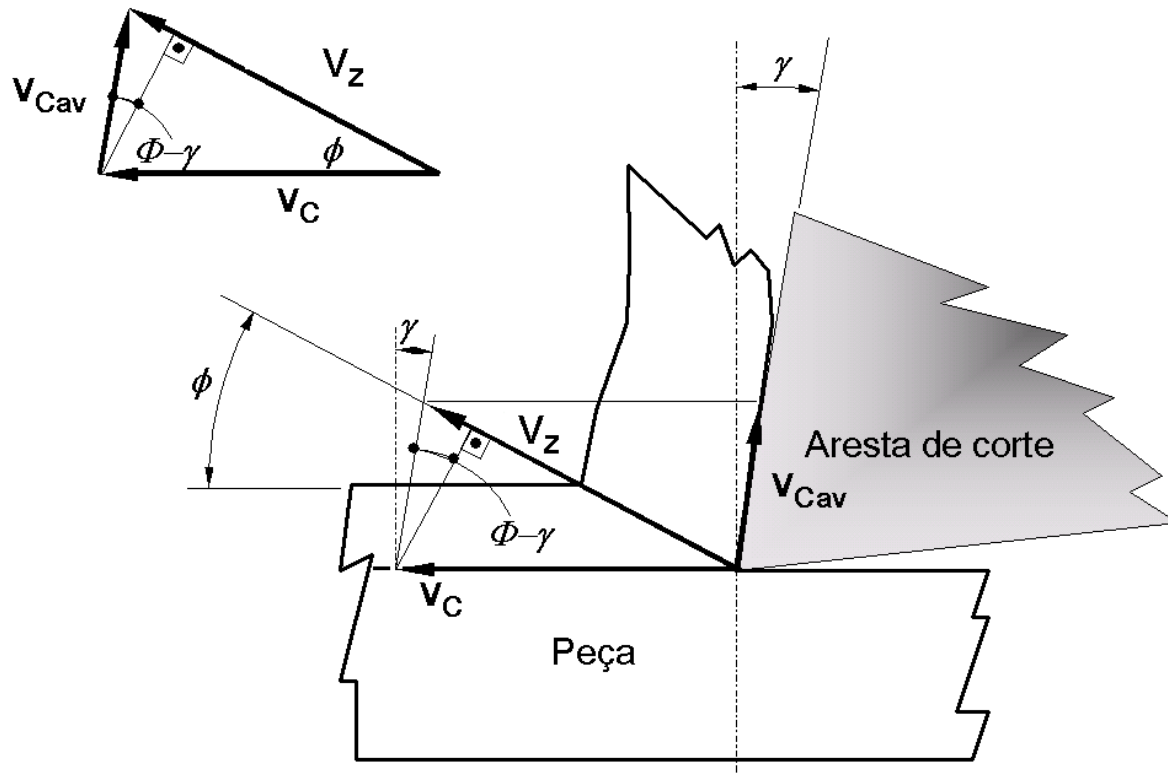

$$v_{Cav} = v_c \cdot \frac{\text{sen}\phi}{\cos(\theta - \gamma)}$$

$$v_z = v_c \cdot \frac{\cos \gamma}{\cos(\theta - \gamma)}$$

$$v_{Cav} = \frac{v_c}{R_c}$$

v_{cav} = Velocidade de saída do cavaco

v_{cs} = Velocidade de cisalhamento

FORMAÇÃO DE CAVACOS

Tipos de cavacos e sua formação

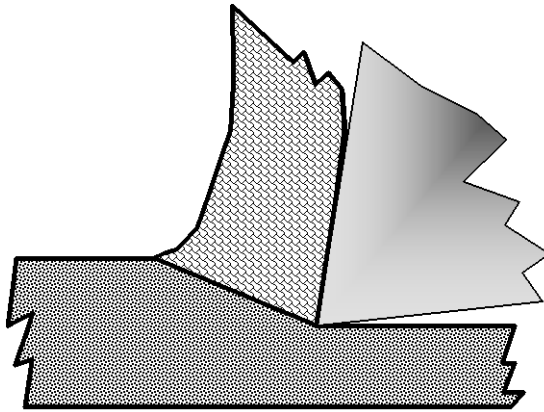

(a) Cavaco Contínuo

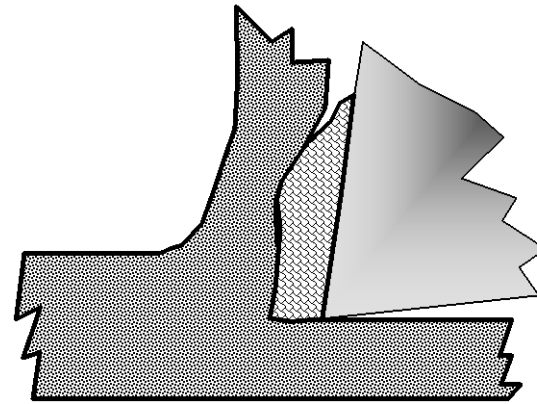

(b) Cavaco Contínuo com APC

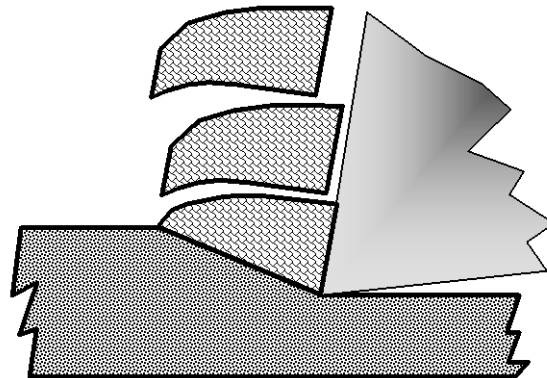

(c) Cavaco Descontínuo

FORMAÇÃO DE CAVACOS

Formas de cavaco



(a) Cavaco em fita



(b) Cavaco helicoidal



(c) Cavaco espiral



(d) Cavaco em lascas

FORMAÇÃO DE CAVACOS

Formas de cavaco em função das condições de corte

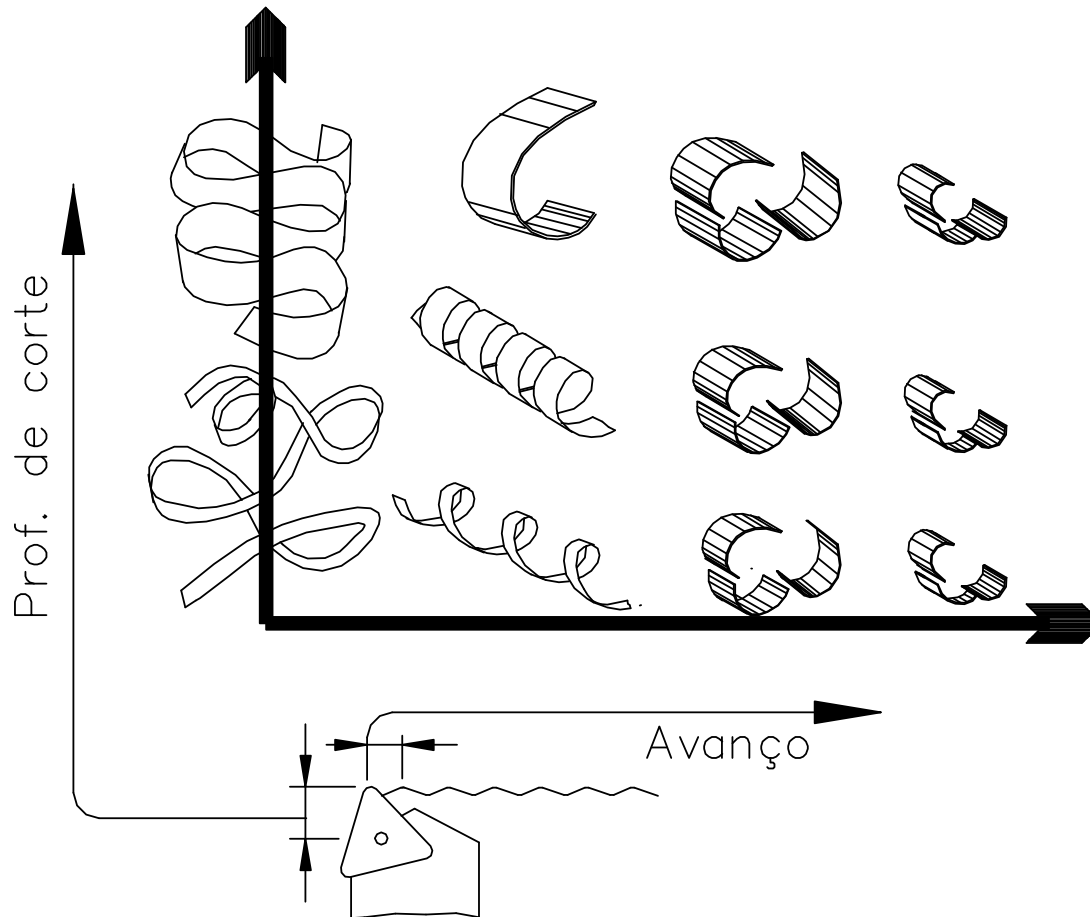

FORMAÇÃO DE CAVACOS

Estudo da formação de cavacos – Quick Stop

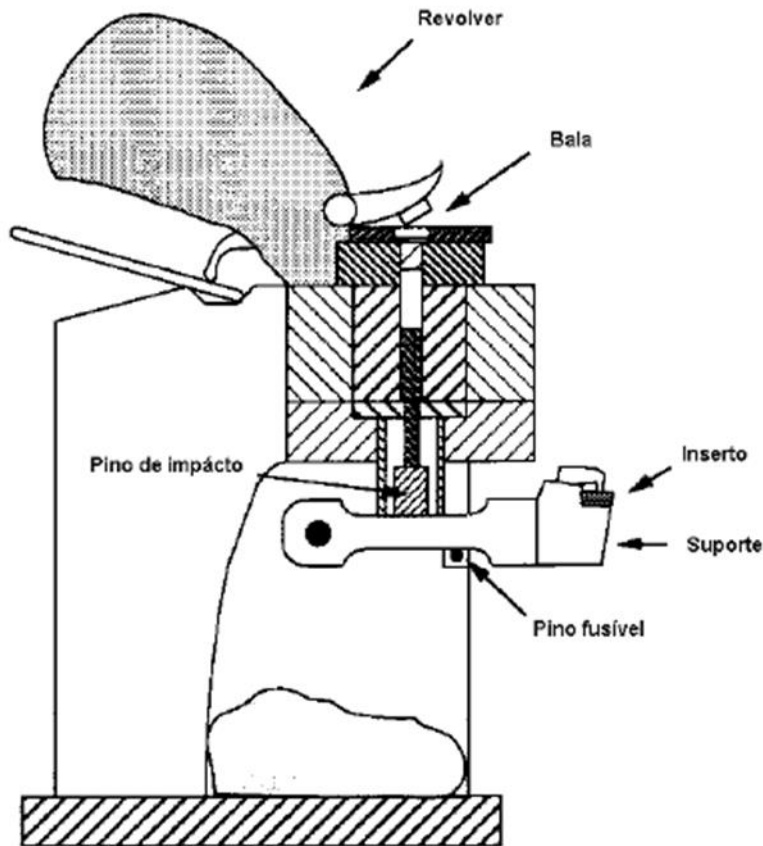

(a) Ruptura por explosão

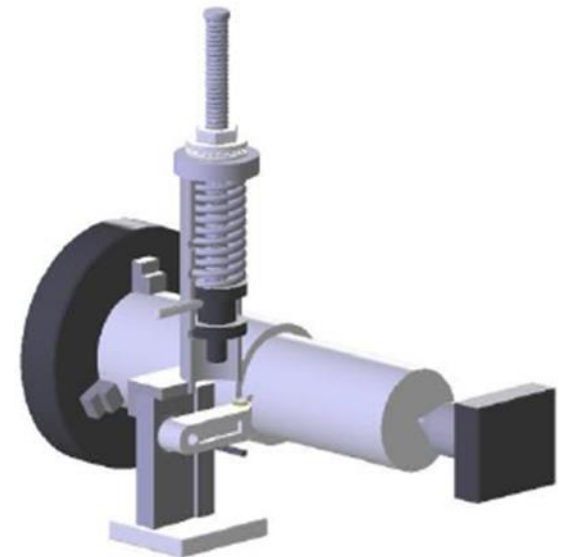

(b) Ruptura por força de mola

FORMAÇÃO DE CAVACOS

Estudo da formação de cavacos – Quick Stop

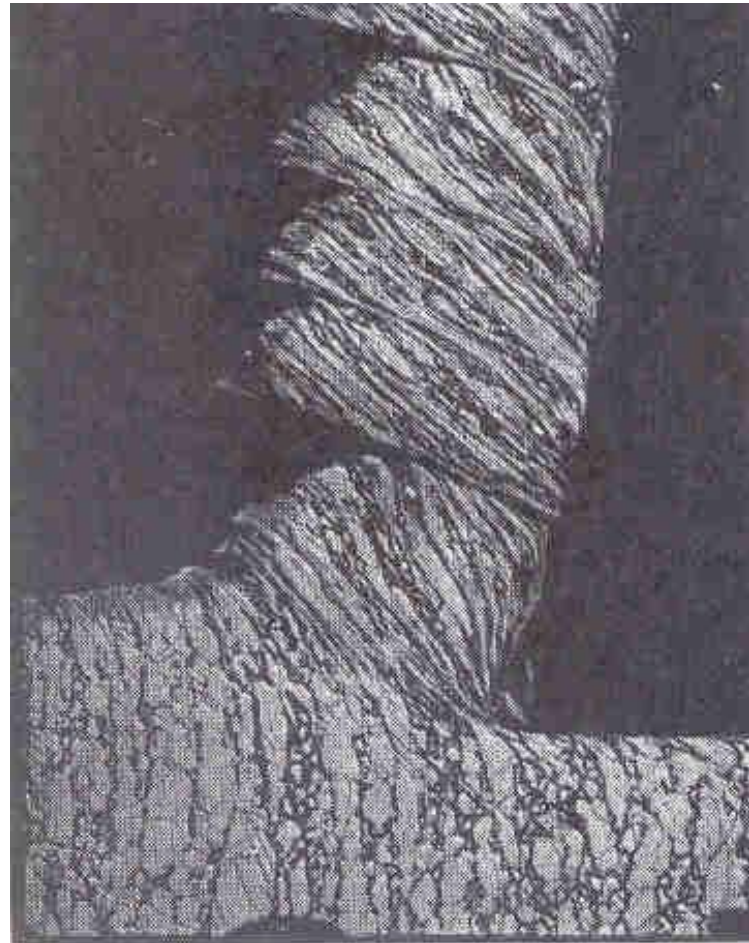
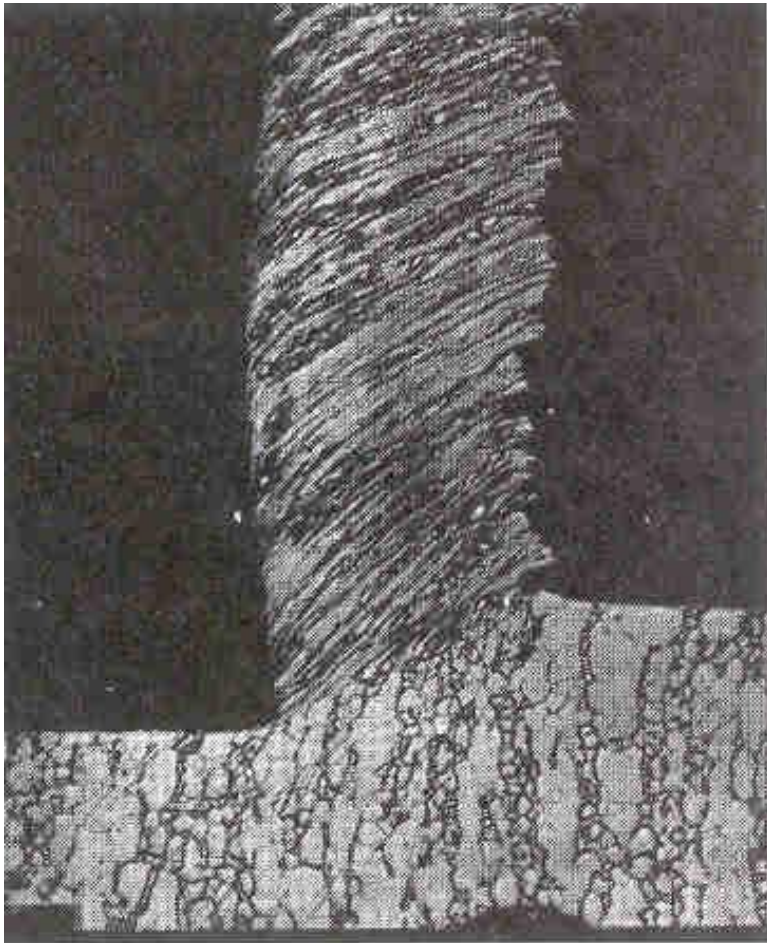

FORMAÇÃO DE CAVACOS

Interface Cavaco-Ferramenta

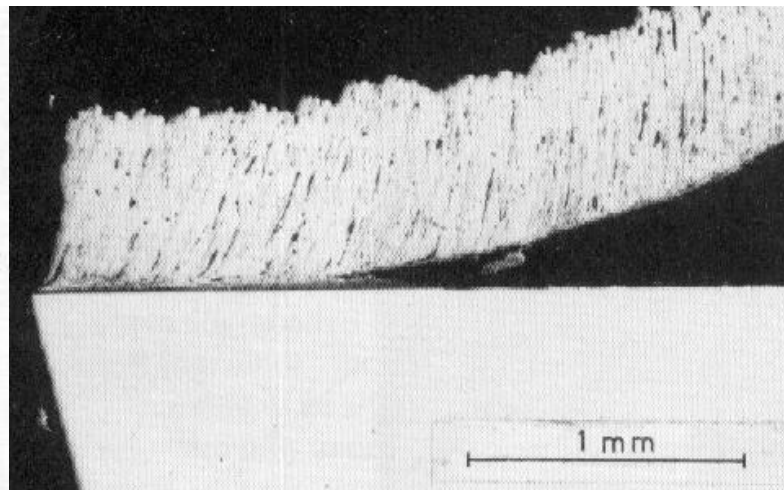
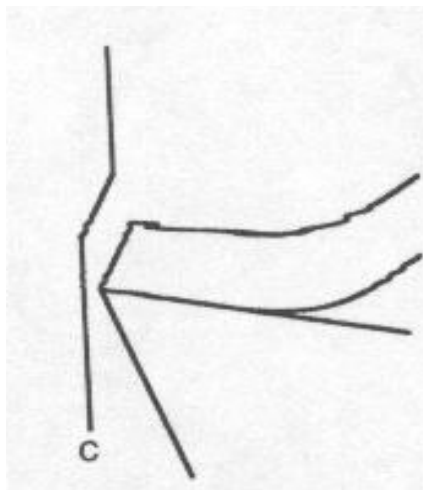
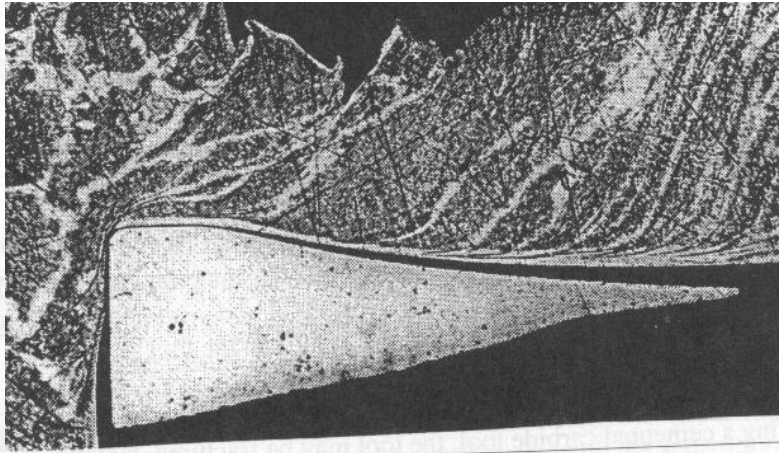
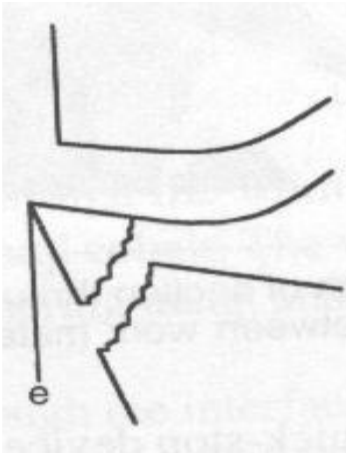

FORMAÇÃO DE CAVACOS

Modelos de formação de cavacos em FEM

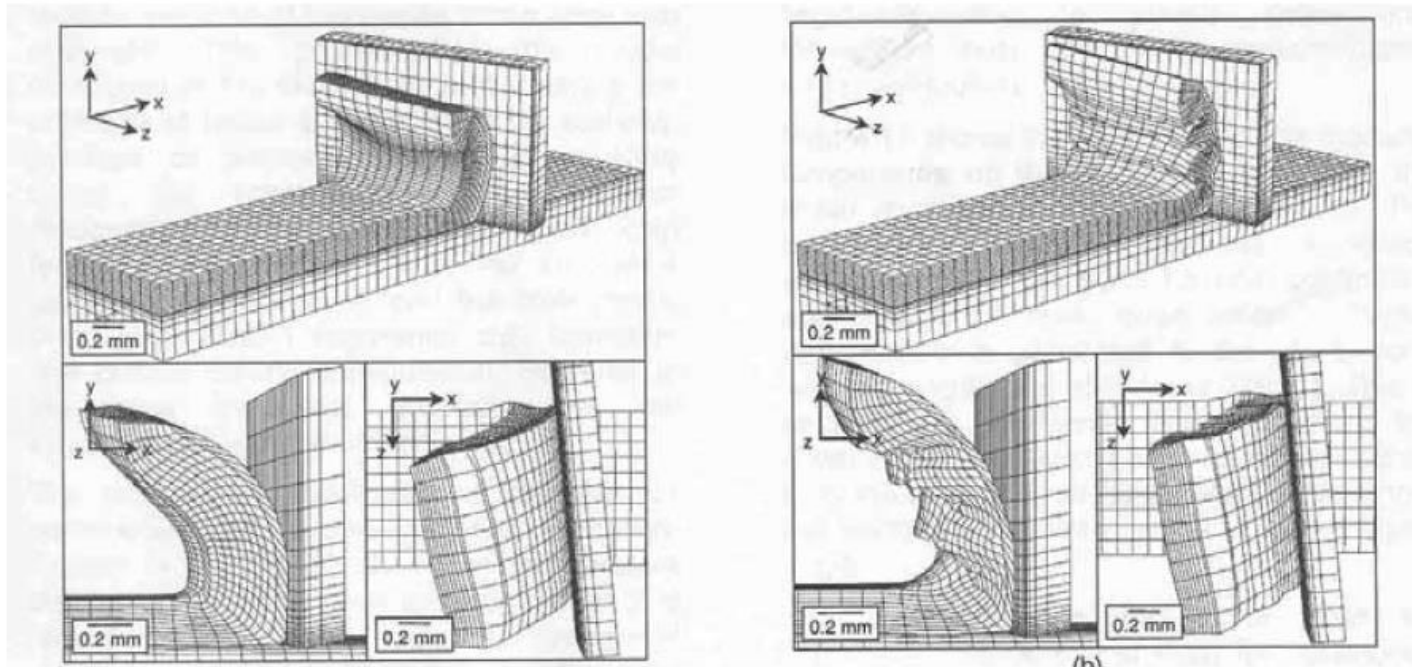

FORMAÇÃO DE CAVACOS

Modelos de formação de cavacos em FEM

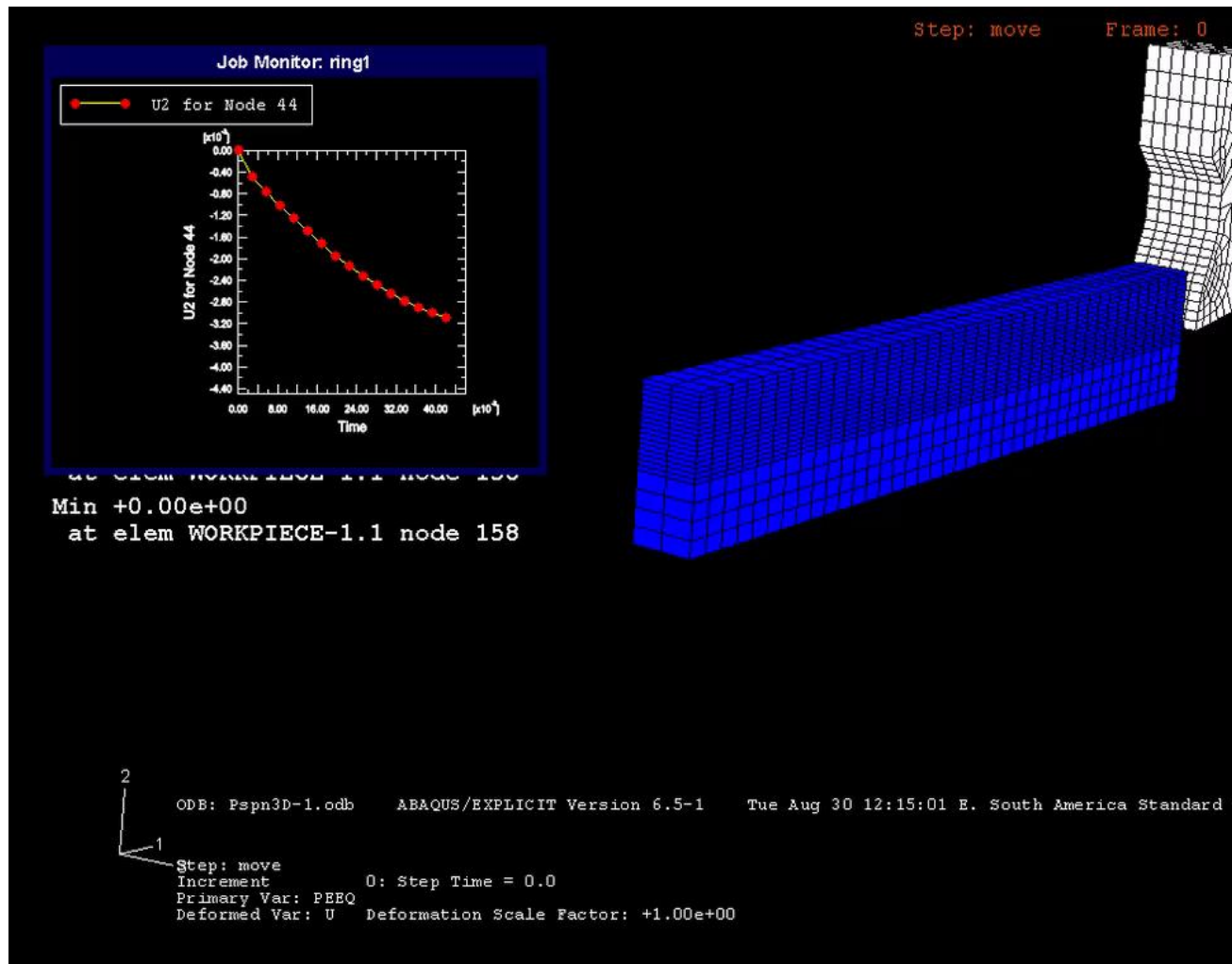

FORMAÇÃO DE CAVACOS

Modelos de formação de cavacos em FEM

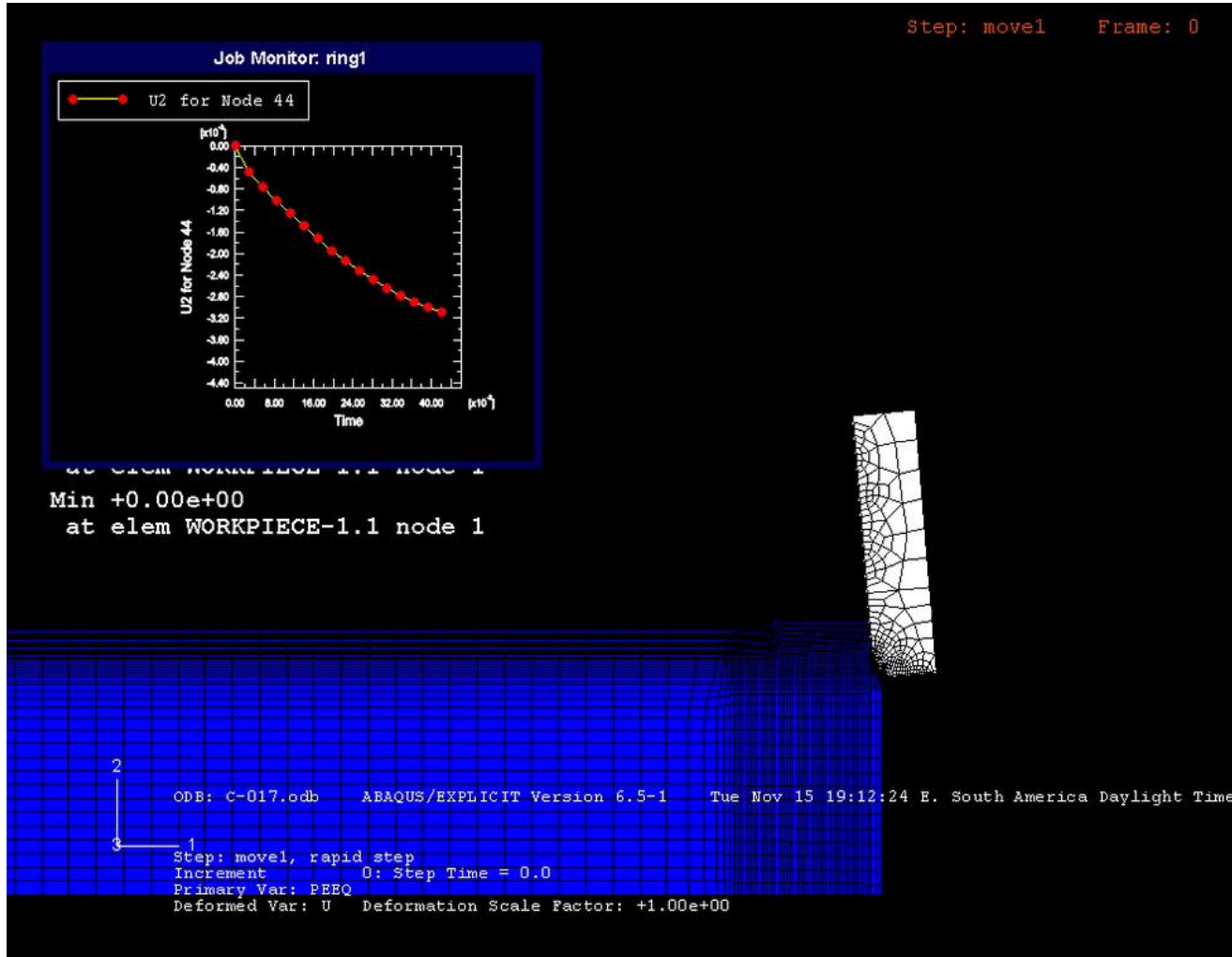

FORMAÇÃO DE CAVACOS

Modelos de formação de cavacos em FEM

