

# Introdução ao estudo de tratores

LER 332 - Mecânica e Máquinas Motoras  
Departamento de Engenharia de Biossistemas

José P. Molin  
ESALQ/USP  
jpmolin@usp.br

# Objetivos específicos

- Conhecer a evolução histórica do trator como fonte de potência na agricultura;
- Conhecer a constituição básica dos tratores existentes no mercado e suas variações;
- Ter noções de mercado de tratores no Brasil.

# Bibliografia

Material no **e-Disciplinas**

As fontes de potência para  
operações agrícolas e florestais

# Humana



# Animal



# Trator



# Os antecessores do trator

Em 1769 James Watt  
patenteou o motor a vapor

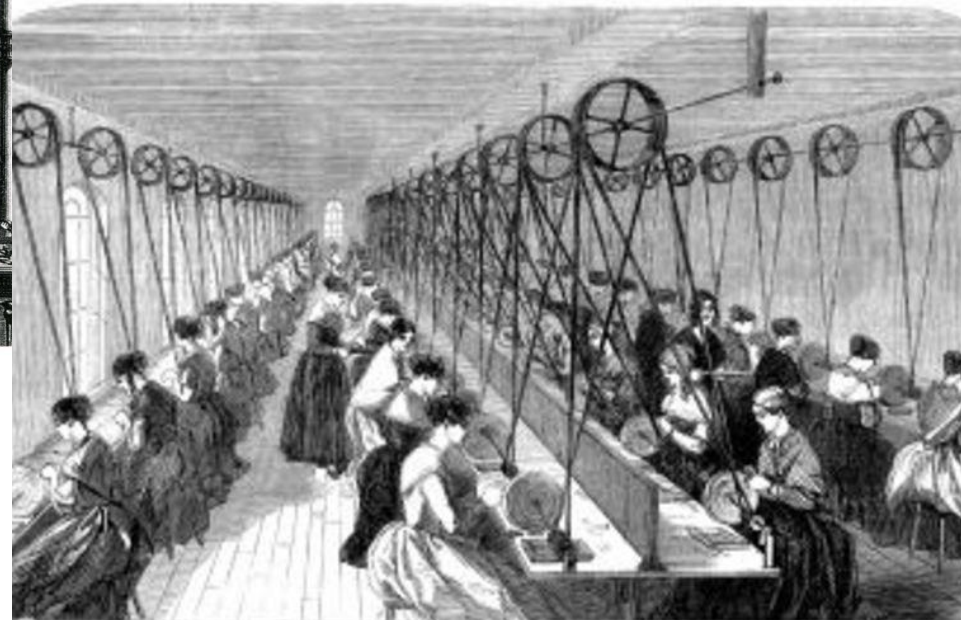
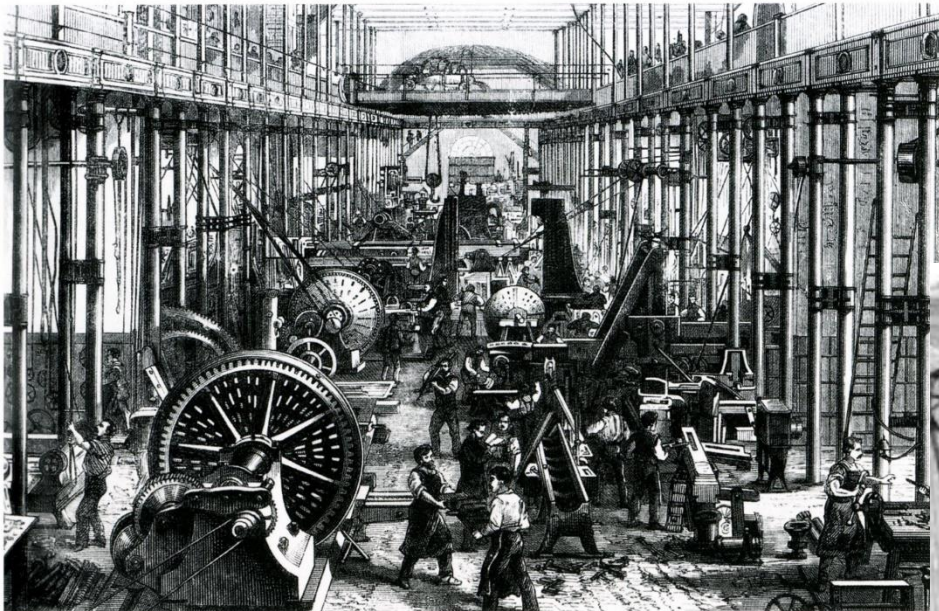
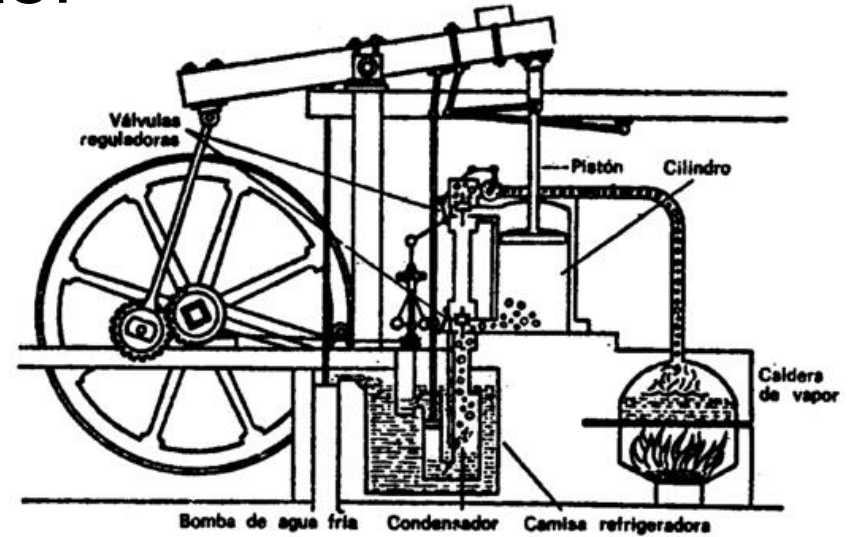

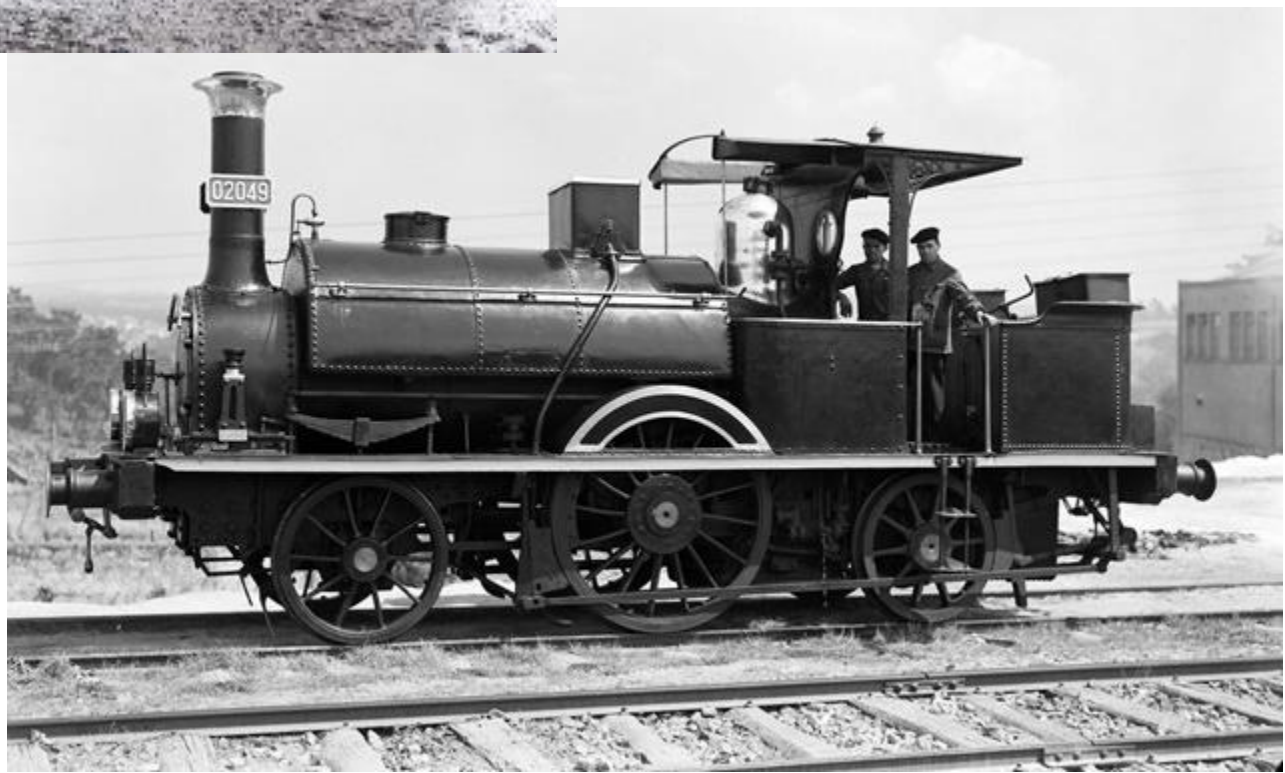
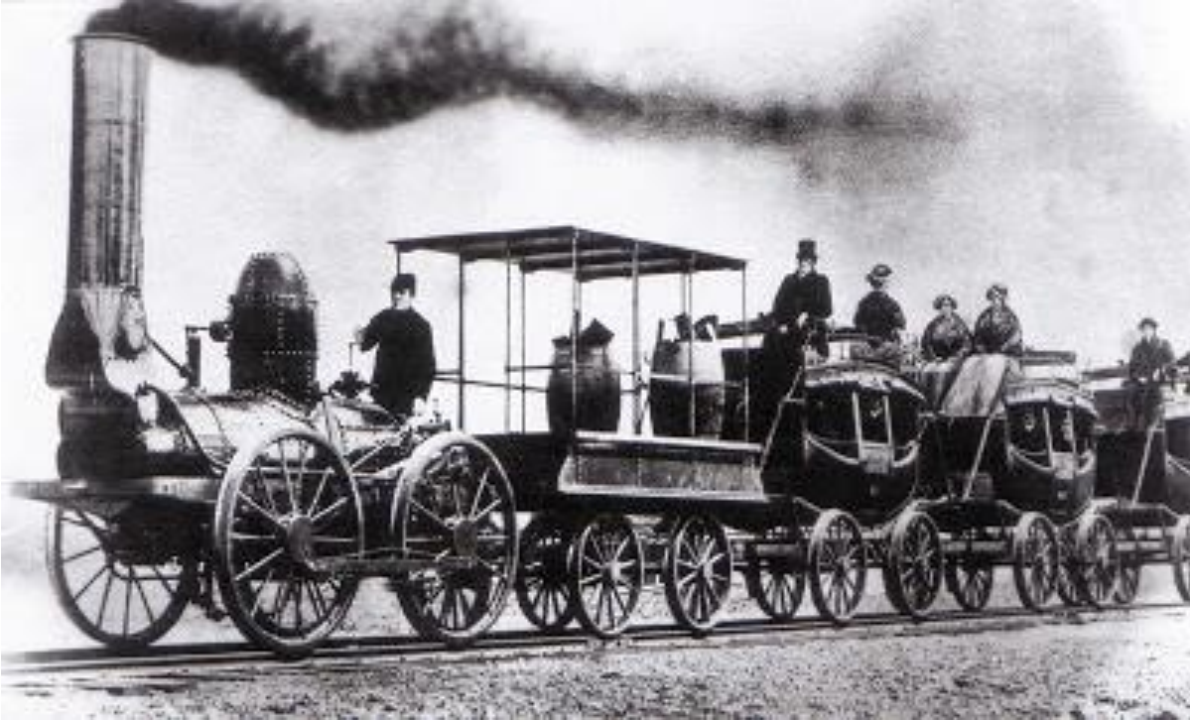



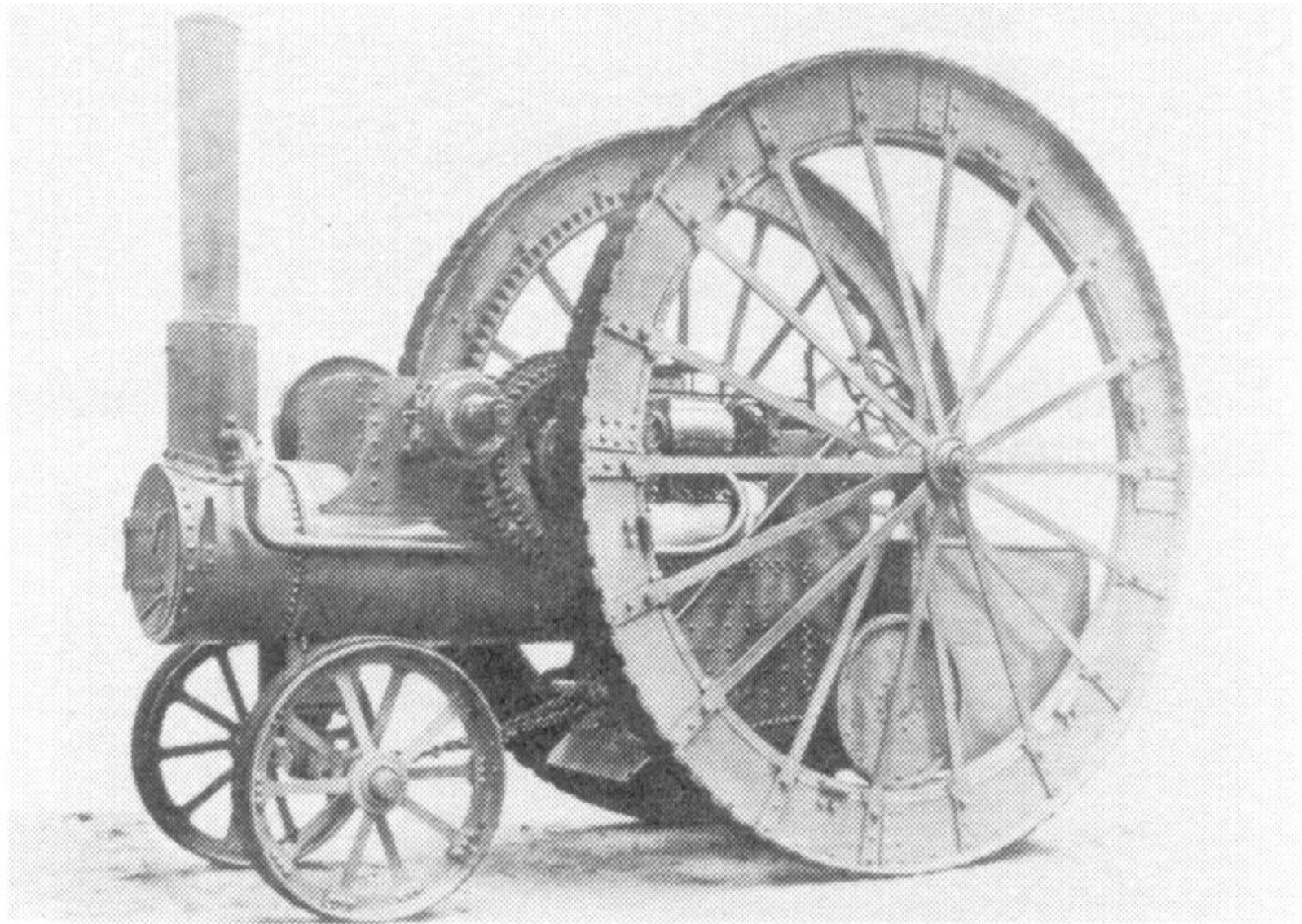

**John Fowler & Co., (Leeds) Ltd., Leeds, England  
(1877)**

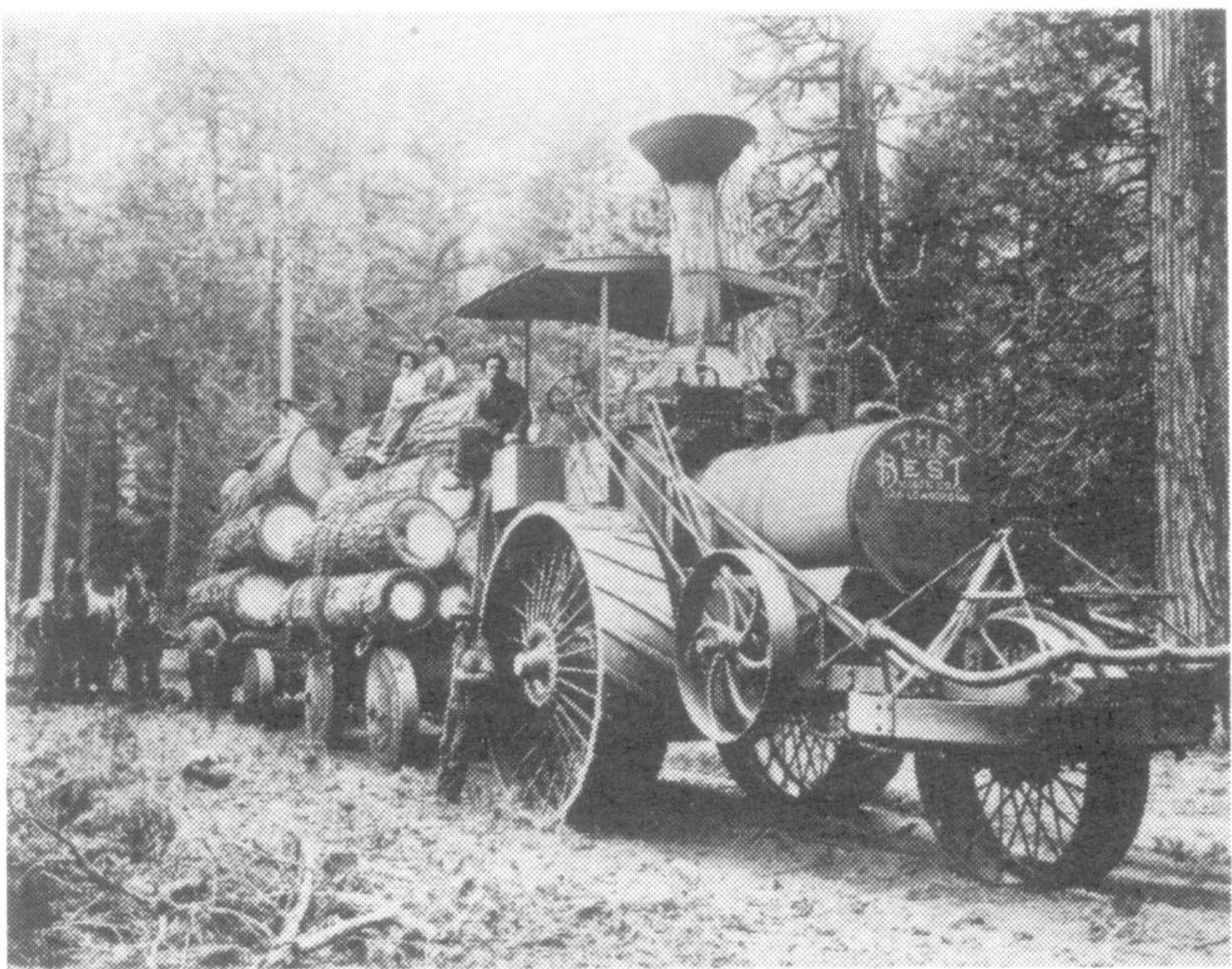

**C. L. Best Steam Tractor (vertical fire tube boiler), 1885. Space between firebox and outer shell formed the water leg and made place for mud to collect.**

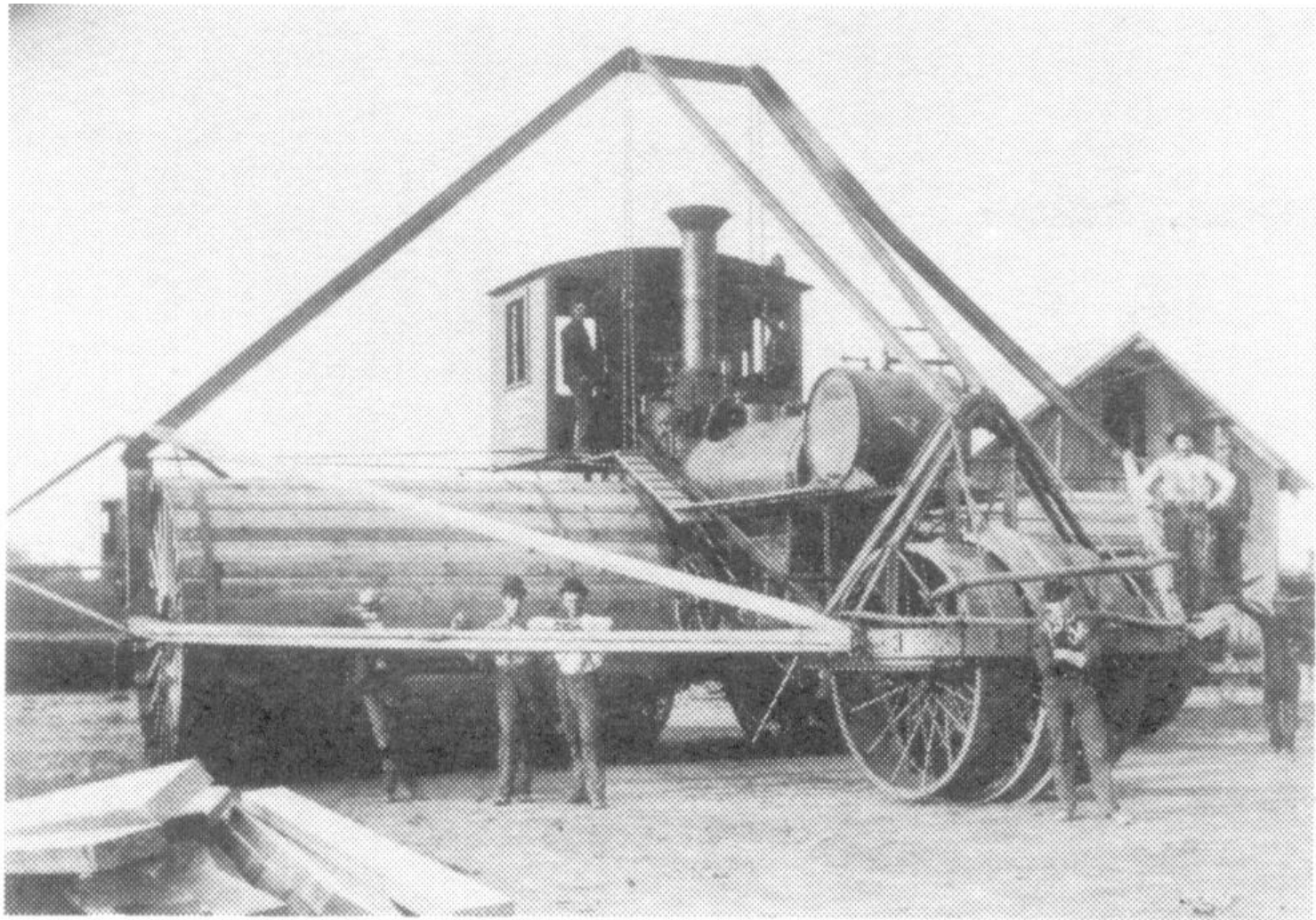

**A big-wheel outfit built by the Best Mfg. Co. in 1900 for the Middle River Farming Company, Stockton, Calif. The wood-covered drivers were 15 feet wide and 9 feet in diameter. Total weight of outfit was 41 tons.**



Os primeiros tratores com motor de  
combustão interna

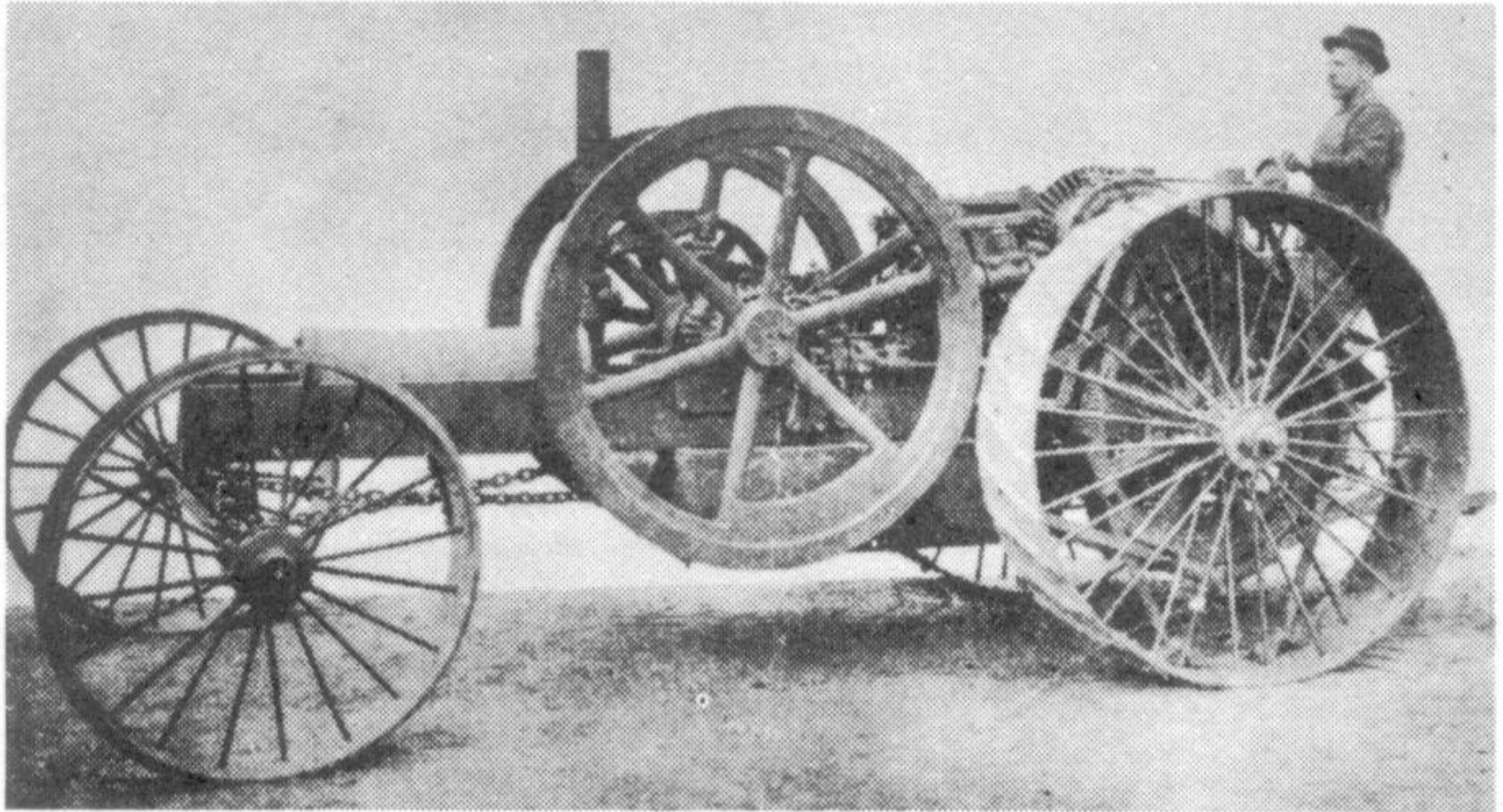

## **1894 Otto**

**15 H.P. Bevel gears and drive shaft in first reduction.**





1870  
1870

22 7'94



O trator agrícola dos tempos modernos

# O trator hoje



4 x 2



4 x 2 TDA  
(Tração Dianteira Auxiliar)



4 x 4



Esteira

# A evolução histórica do trator

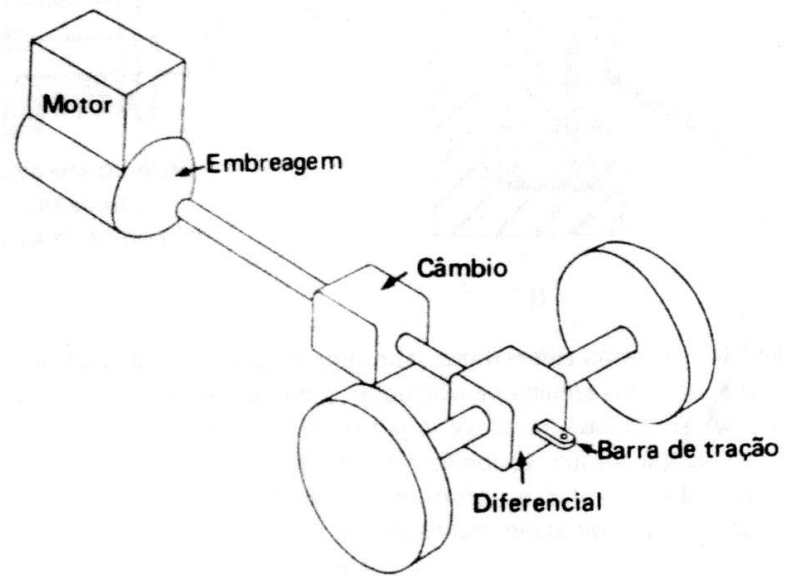

Pouca  
diferença  
com o  
automóvel



# A evolução histórica do trator

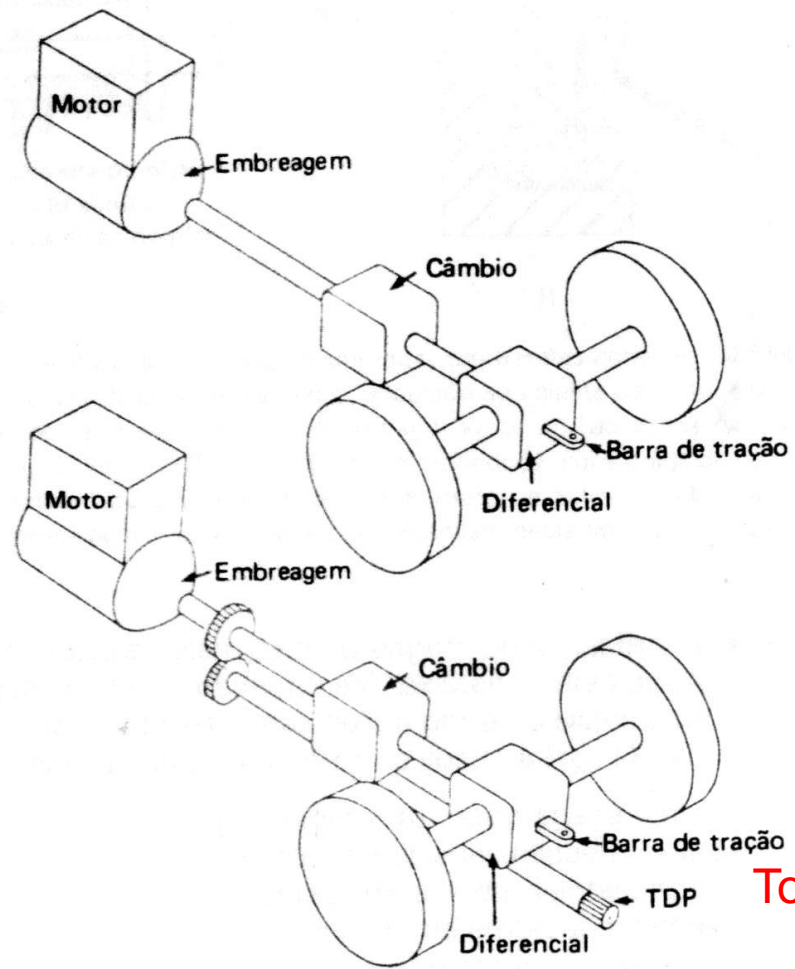

Tomada de Potência

# A evolução histórica do trator

Começa a se diferenciar do automóvel

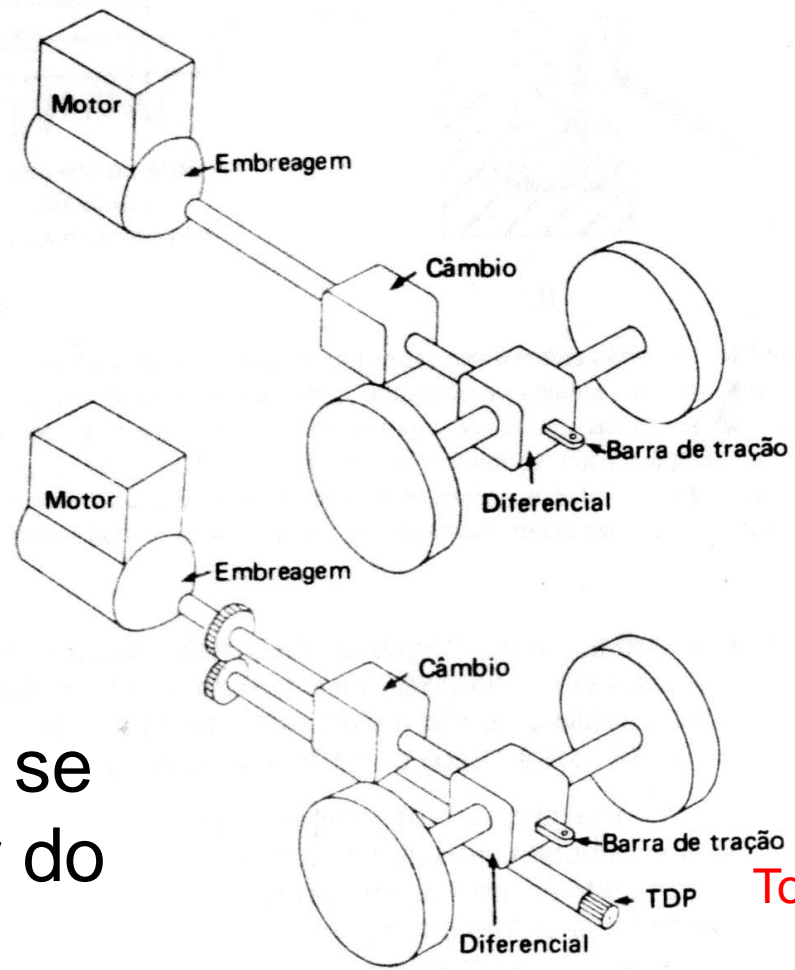

# A evolução histórica do trator

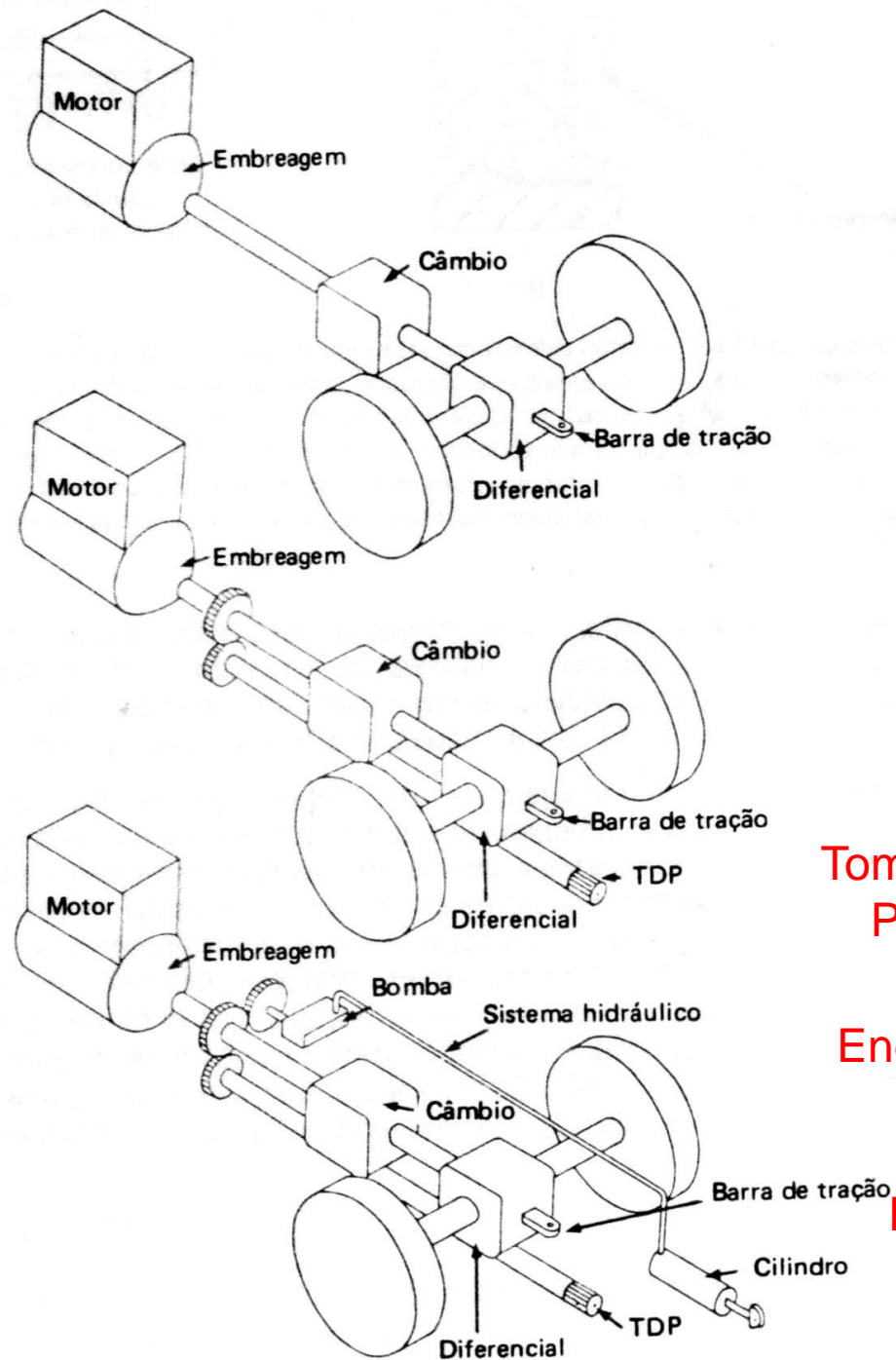

Tomada de Potência

Engate de 3 pontos e sistema hidráulico

# Trator Agrícola

O trator deve permitir:

- tracionar máquinas e implementos de arrasto através da barra de tração
- tracionar e carregar máquinas e implementos montados através do engate de três pontos com levante hidráulico
- acionar máquinas estacionárias, rebocadas ou montadas no seu engate de três pontos através da árvore de tomada de potência (TDP).

# Trator Agrícola

É aquele que dispõem de:

- barra de tração
- TDP
- engate de três pontos com levante hidráulico



# Trator 4 x 2



# Trator 4 x 2

- rodado de pneus
- rodado traseiro maior que o dianteiro
- tração apenas no rodado traseiro
- peso concentrado no rodado traseiro (70%)
- rodas dianteiras apenas de apoio e de esterçamento (direção)
- permite ajuste de bitolas



# Trator 4 x 2 TDA

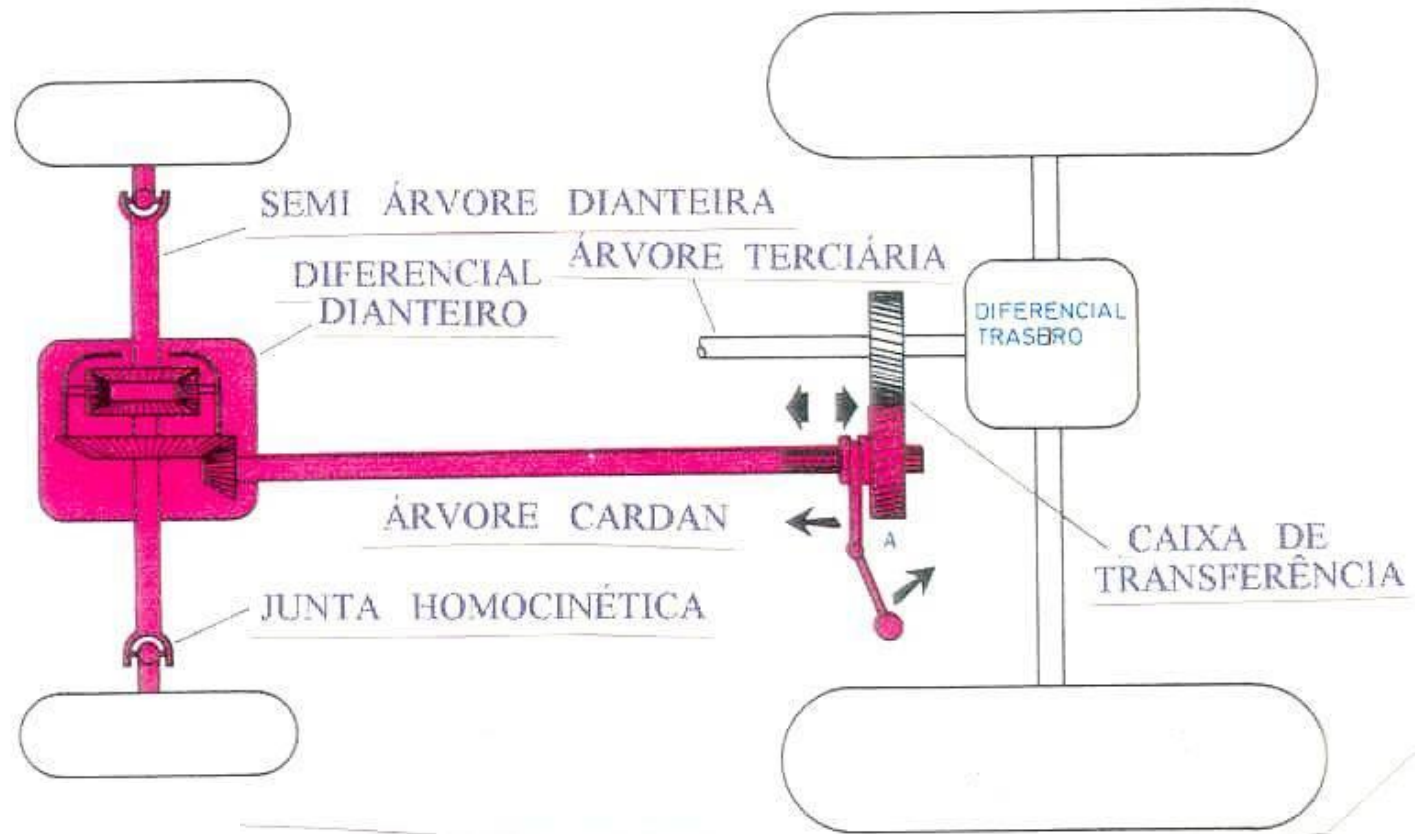
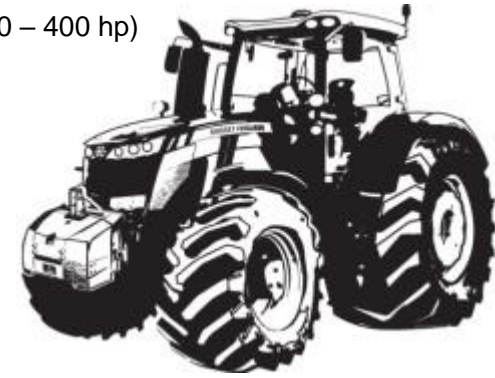

Trator 4 x 2 TDA de 500 hp (368 kW) de potência lançado em 2015 na Alemanha



# Trator 4 x 2 TDA

- rodado de pneus
- rodado traseiro maior que o dianteiro
- tração no rodado traseiro e no dianteiro apenas quando acionado
- peso distribuído entre o rodado traseiro (60%) e o rodado dianteiro (40%)
- rodas dianteiras para esterçamento (direção) e tração
- permite ajuste de bitolas

# Trator 4 x 4

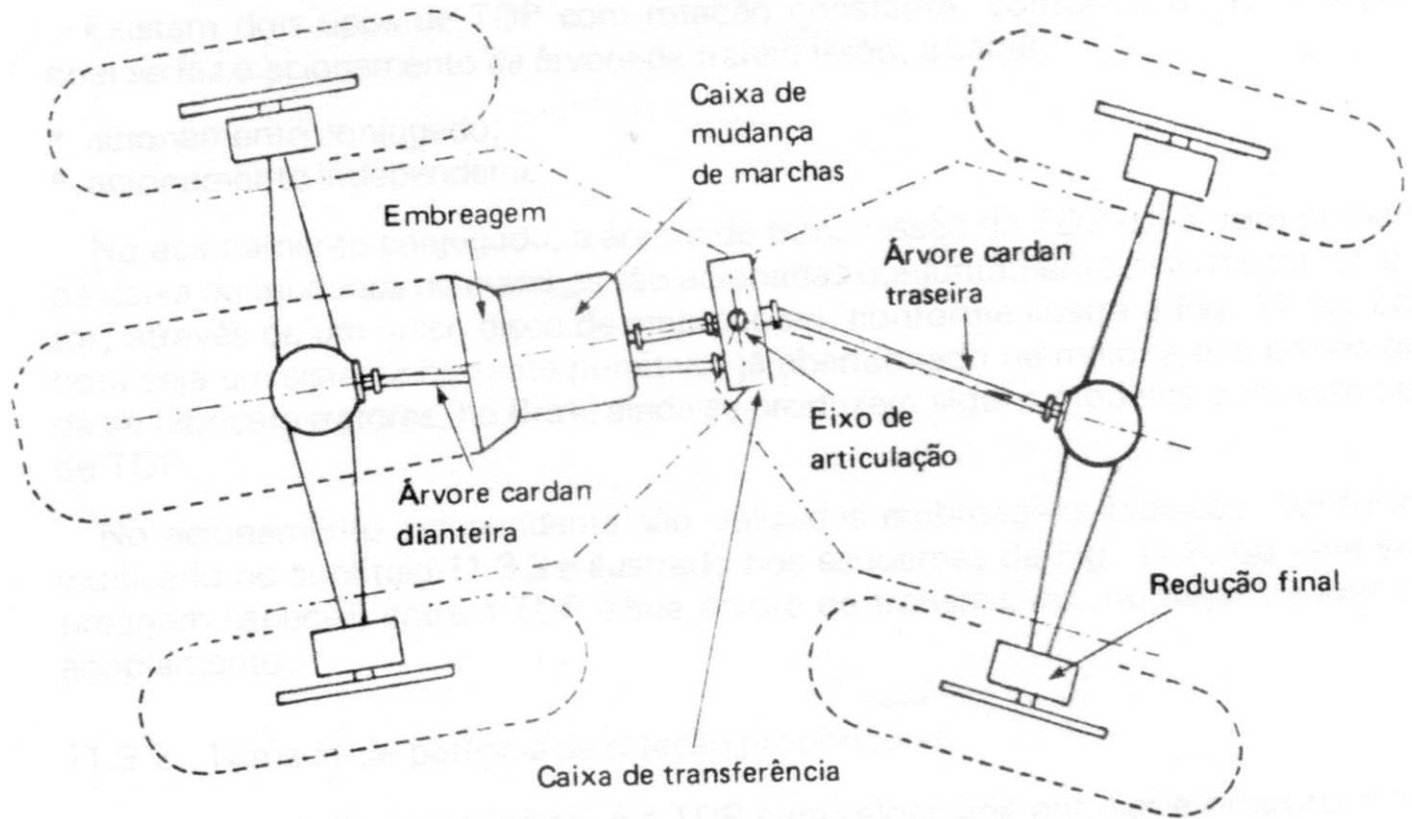



TM14

MULLER



STR-360

**TITAN**



# Agrishow 2014



# Trator 4 x 4

- rodado de pneus
- rodado traseiro e dianteiro iguais
- tração permanente nas quatro rodas
- peso uniformemente distribuído entre os dois eixos
- normalmente a direção é dada pela articulação do chassi
- não permite regulagens de bitola

# Trator de esteiras



# Esteiras de aço

## Vantagens

Maior área de contato com o solo:

- maior eficiência na tração (maior aproveitamento da potência gerada no motor)
- menor pressão sobre o solo (menor compactação do solo)

## Desvantagens

- velocidade de trabalho limitada
- o trator não pode trafegar em estradas pavimentadas
- não é recomendável transitar a longas distâncias de deslocamento
- não apresenta opção de regulagem de bitola

Os primórdios das esteiras

Sapatas para aumentar a área de contato das rodas

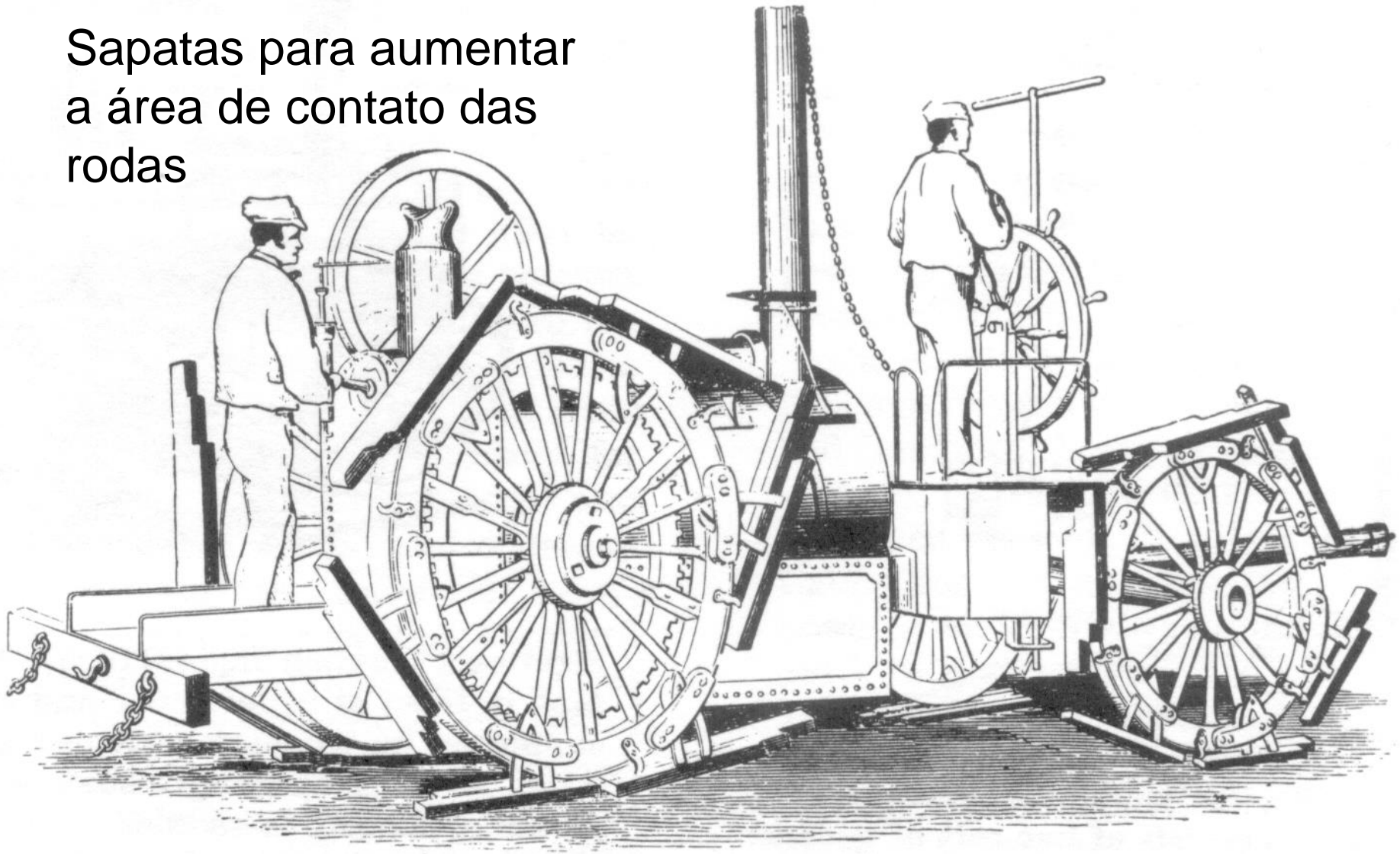

**Track-laying steam traction engine of Boydell, 1846. Used by British Army during the Crimean War, 1854.**



**1916 Altgelt "Walking tractor"**

Sapatas para aumentar a área de contato das rodas – produto de mercado

... ou aumentar a largura das rodas para aumentar sua área de contato

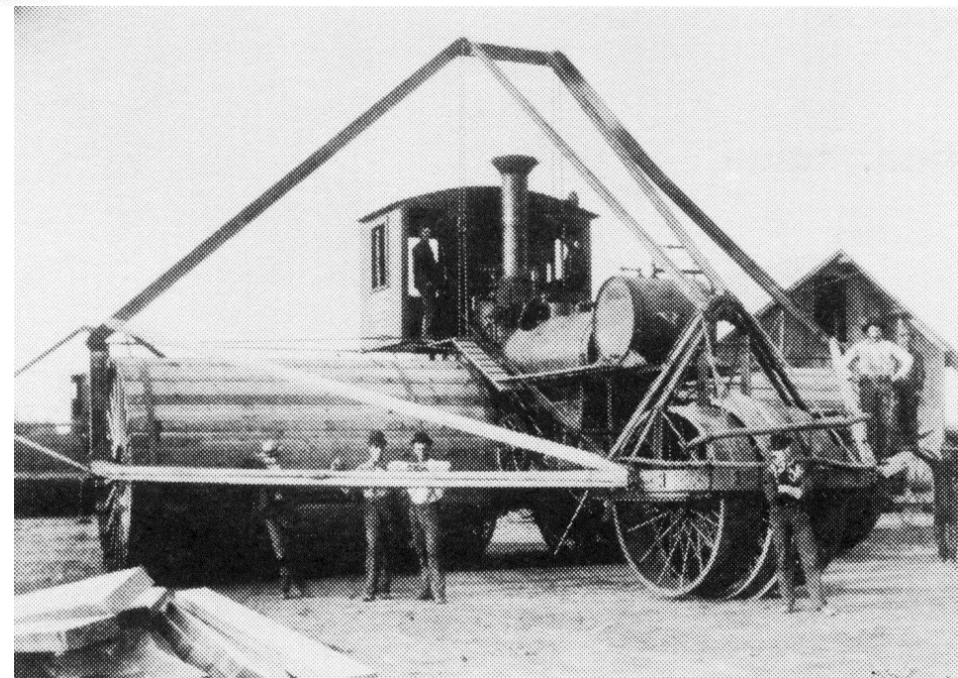

# A primeira esteira ou “roda flexível”

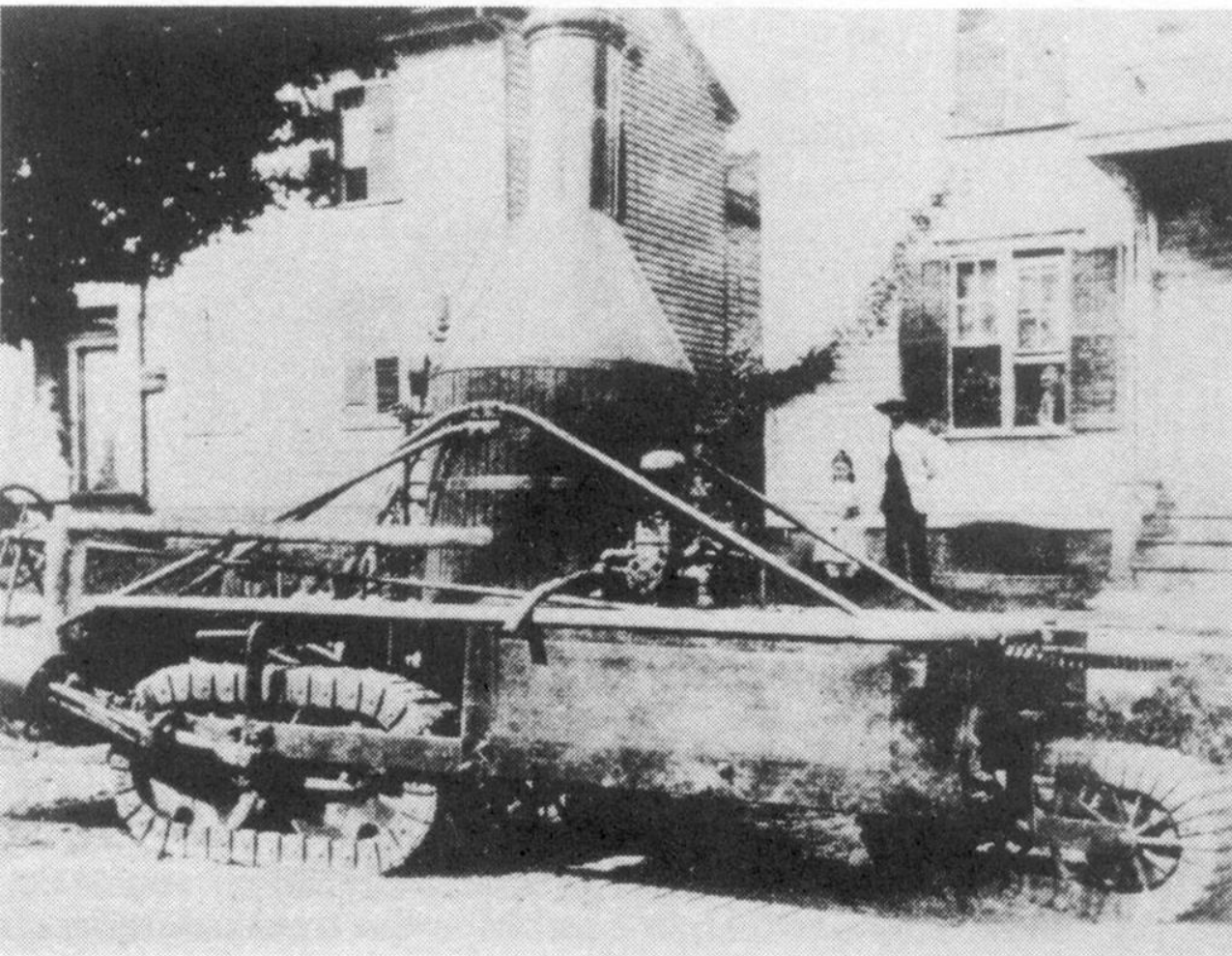

**Minnis crawler, 1867  
(Courtesy Hal Higgins)**



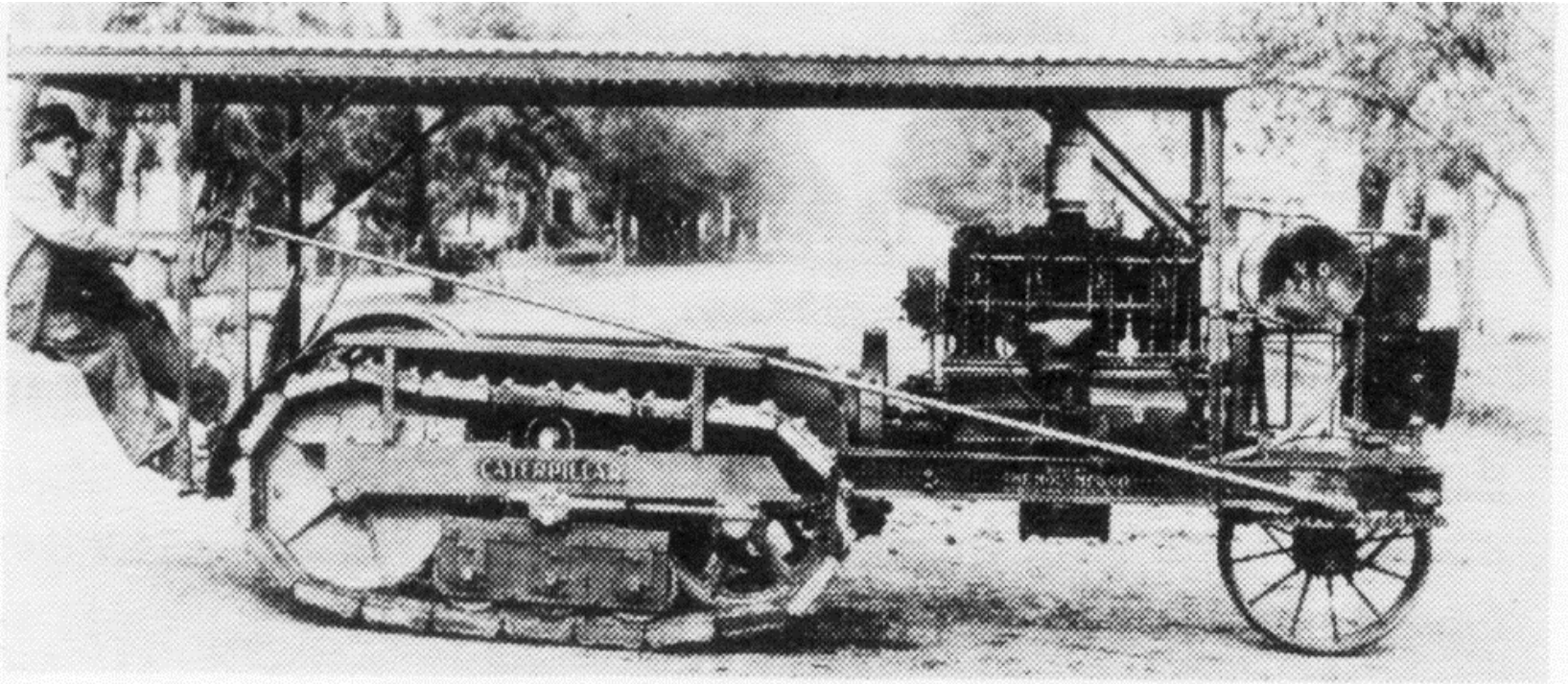

## **1912 Holt (gasoline)**

**30 H.P. Built low for orchard work. Both sprockets and idlers journaled on full-width transverse axles. Track frames pivoted to the main frame at a point midway between track and frame ends. Steering accomplished by hand wheel and worm gear arrangement.**

O desafio de reinventar o  
trator de esteiras...

# A moderna esteira de borracha



1984

Brasil -1986





JOHN DEERE 8540

WILLIAMS SALES  
1234567890

WILLIAMS SALES  
1234567890













22









out yield.

Die Kabine.

PB  
CL2015

Kat 4 filtration.

**CLAAS**

Mehr vom Herbst  
Agritechnica2015

MAGDALENA

LA MAGDA

WICHMAN

riCHV  
cs



Agrishow 2014





Agrishow 2018



# Vantagens das esteiras de borrachas

- Sobre os tratores de pneus
  - menor compactação do solo
  - maior eficiência tratória
  - menor consumo
- Sobre as esteiras de aço:
  - maior facilidade em manobras
  - facilidade para o deslocamento
  - possibilidade de operar em maiores velocidades
  - maior conforto para o operador

Variações e tratores conceito

# Microtrator de rabiças



... por exemplo,  
para fruticultura



... trator tipo  
“pórtico”



... trator tipo porta máquinas



Tratores e fontes de potência especiais

... no Brasil





Chassi de Rural ou  
Jeep Willis 4 x 4 e  
motor estacionário

... caminhão 6 x 4 com  
pneus especiais,  
especialmente para  
semeadura direta





E esses são tratores agrícolas?



E esses são tratores agrícolas?



Tratores conceito









# Trator conceito apresentado pela AGCO/Fendt na Agritechnica 2007

*Fendt's Trisix turns in a 14m circle, making it as manoeuvrable as its much smaller Vario 900 sibs. The tight turn comes from the front- and rear-axle steering, which pivots the tractor about its non-steering centre axle.*



it into production and notching up sales success. The theory would seem to be sound: Six wheels provide the traction of an artic, while the in-line configuration and four-wheel steering confer manoeuvrability of a crawler. Gross simplification, maybe, but that's the nub of it. Developing these benefit claims a little further, the three axes and six similarly sized 650/65R38 tyres



*Three axes, six wheels, 19t and 7.60m long, 400kW/540hp and 65km/hr maximum speed. The Fendt Trisix is not short on spec.*

advantages: Larger contact patch a more compact than a big artic; high speed and comfier than a crawler. A





Trator conceito  
apresentado pela  
Deutz-Fahr na  
Agritechnica 2009

# Recentes inovações - conforto

Ex.: cabine com suspensão independente e auto-nivelante



# Recentes inovações - eletrônica embarcada e automação



# Mercado de tratores no Brasil

# Evolução da frota nacional

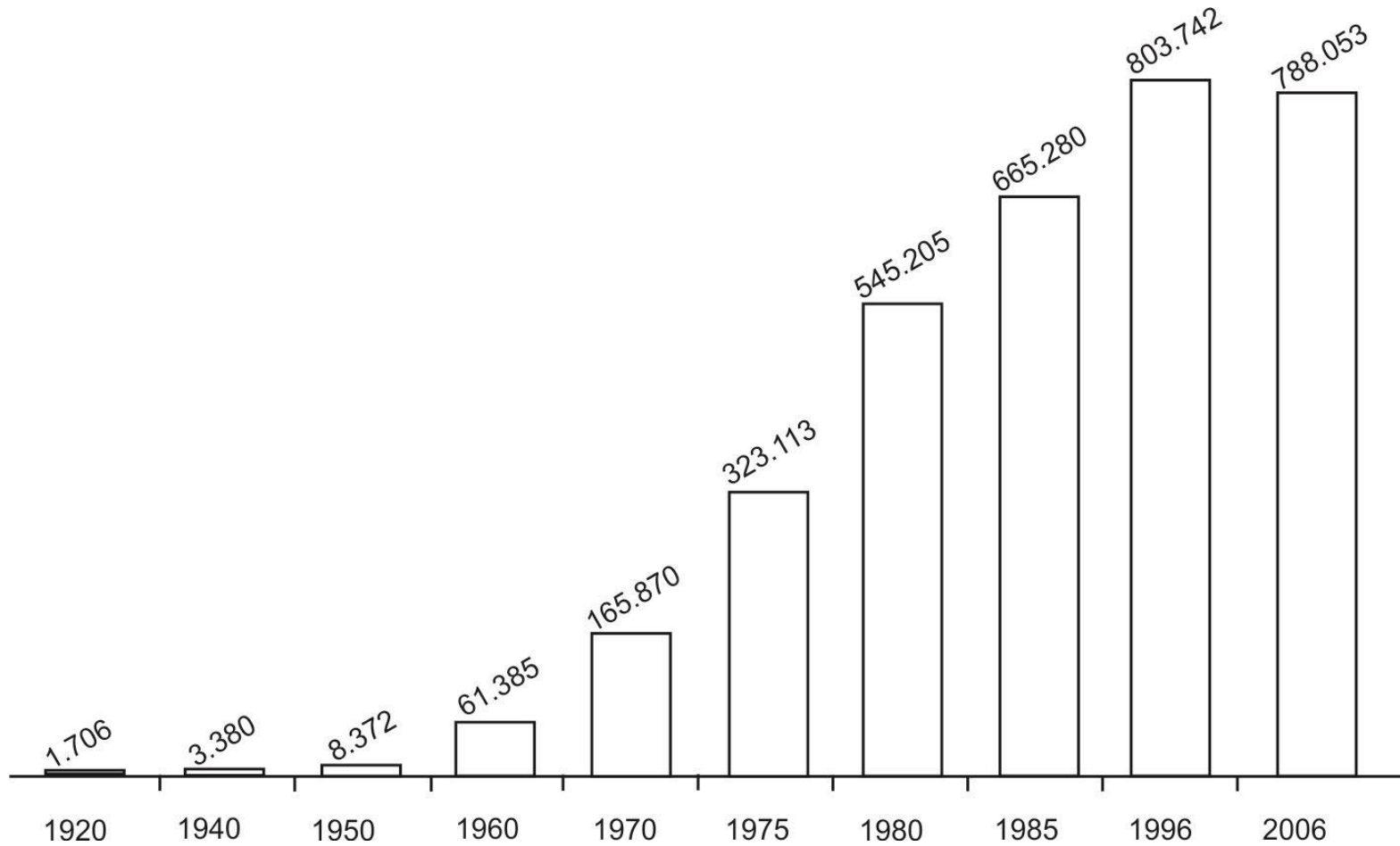

Fonte: IBGE (2010).

# Mercado Interno de Tratores

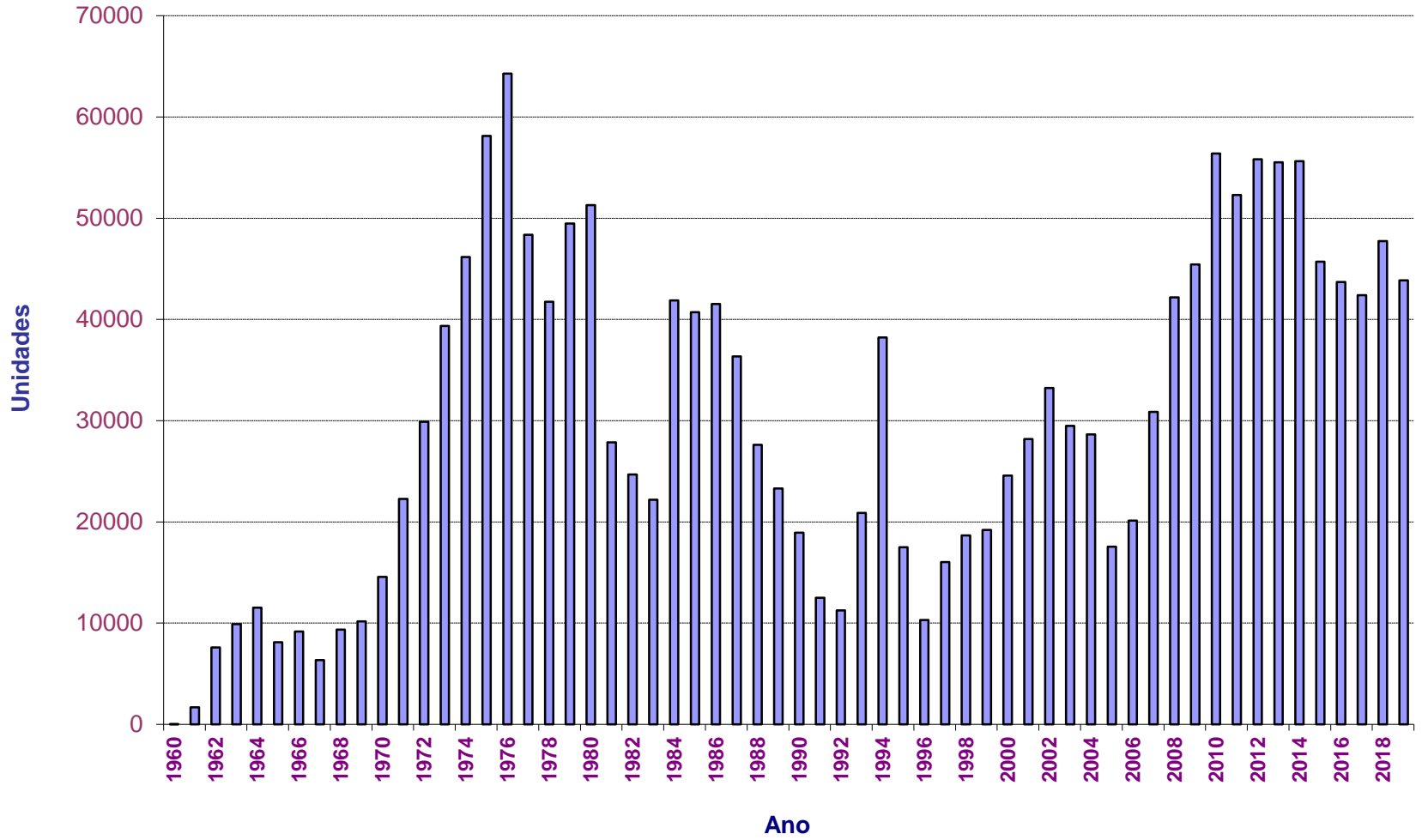

# Fabricantes de tratores no Brasil

Vinculados à ANFAVEA:

- AGCO
  - Massey Ferguson – Canoas, RS
  - Valtra – Mogi das Cruzes, SP
- Agrale
  - Agrale - Caxias do Sul, RS
- CNH
  - Case – Curitiba, PR
  - New Holland – Curitiba, PR
- John Deere
  - John Deere – Monte Negro, RS

Outros:

Agritech Yanmar (Indaiatuba, SP)

LS Mtron (Garuva, SC)

Mahindra (Dois Irmãos, RS)

Stara (Não-Me-Toque, RS)

Landini (Contagem, MG)

Tramontini (Venâncio Aires, RS)

Budny (Içara, SC)

Coyote (Taió, SC)

Ursus (Nova Petrópolis, RS)