

Experimento II: Extensometria

Profa. Dra. Larissa Driemeier

Prof. Dr. Marcilio Alves

Prof. Dr. Rafael Traldi Moura

The background of the slide features a dark blue gradient with several out-of-focus, glowing blue circles of varying sizes, creating a bokeh effect.

Parte numérica: Tutorial Abaqus

Vamos analisar as tensões e deformações de uma placa engastada de aço com furo, cuja geometria e carregamento estão mostrados na figura ao lado. Para isso, usaremos o software comercial de elementos finitos Abaqus®.

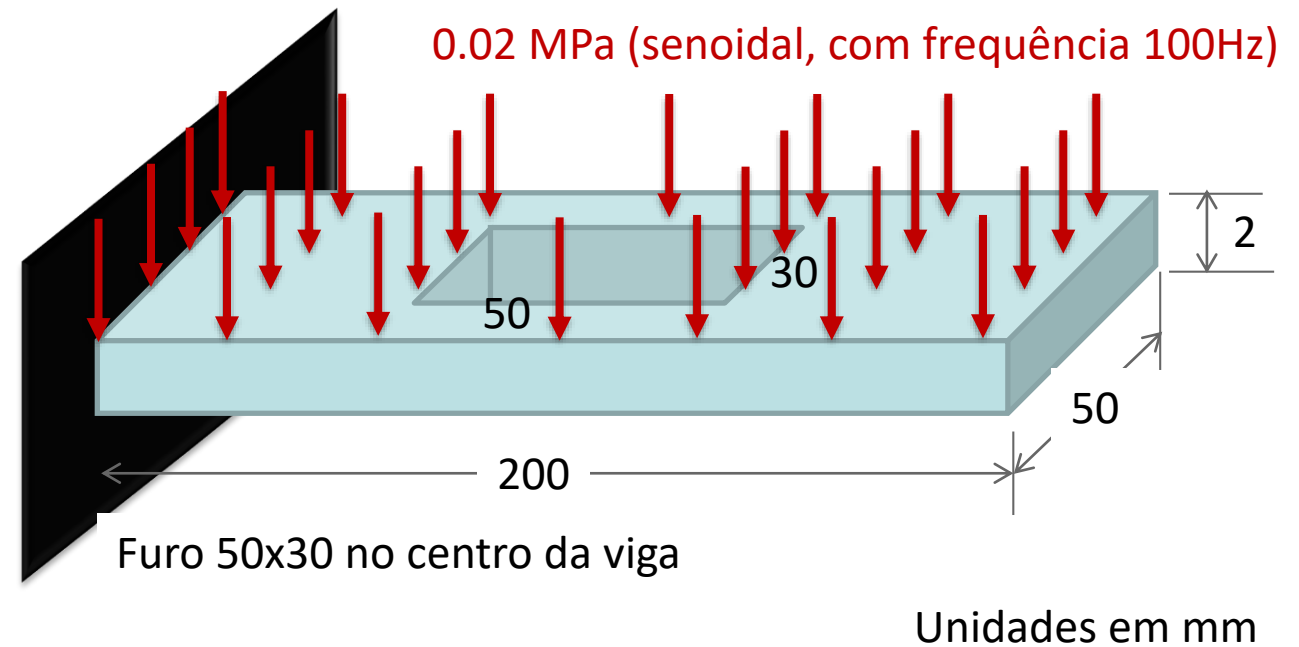



Procure em sua área de trabalho o ícone do Abaqus.

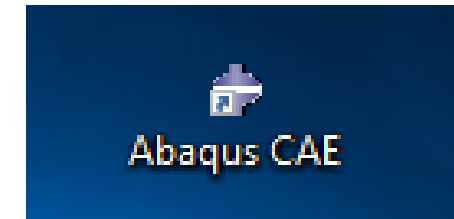

Haverá verificação de licença e depois a seguinte janela se abre:

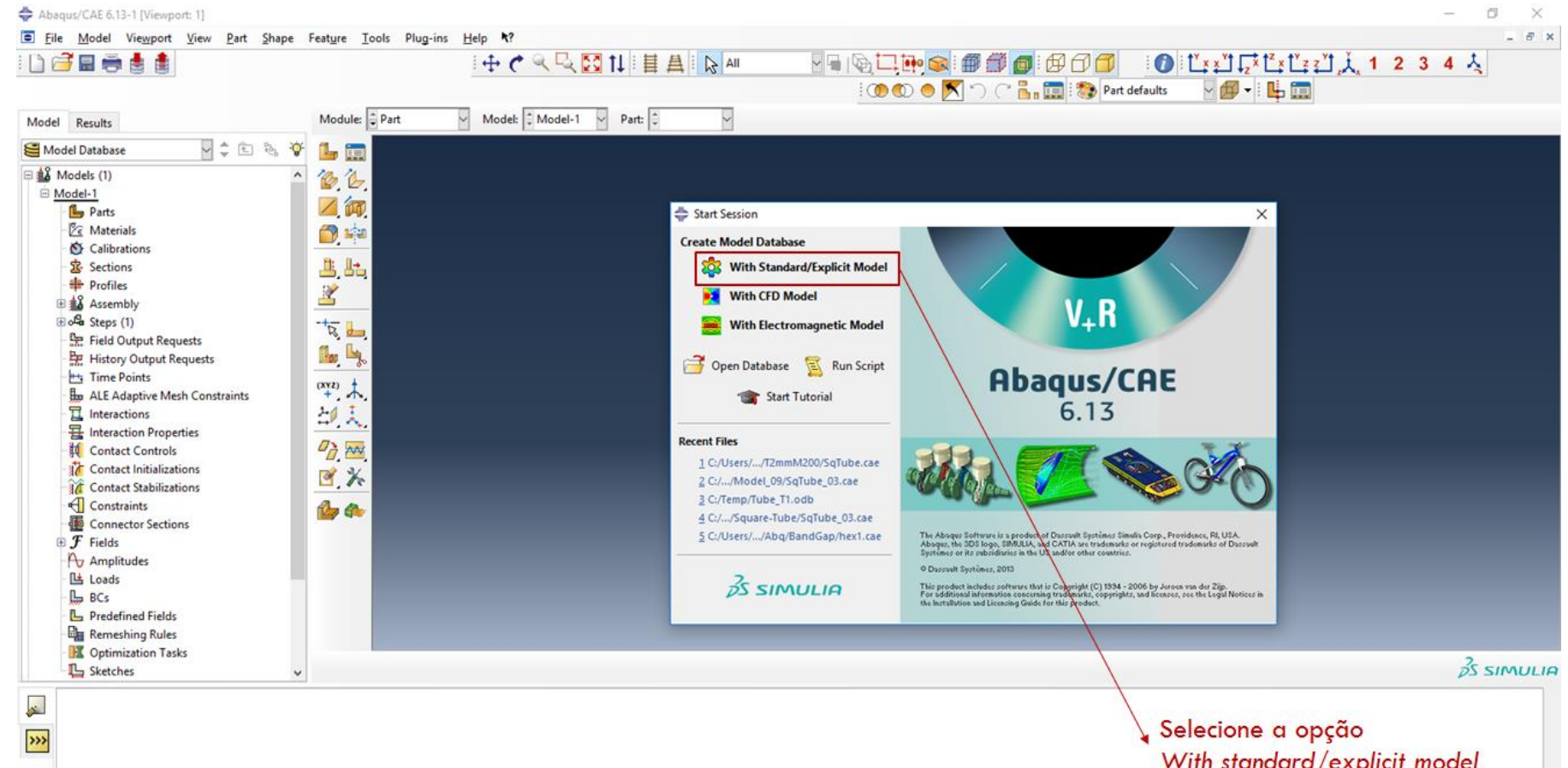

Selecione a opção
With standard/explicit model



- Você irá fazer o tutorial para análise modal de uma placa de aço $200 \times 50 \text{ mm}^2$, espessura de 2 mm , engastada em uma extremidade e livre na outra. O furo tem dimensão $50 \times 30 \text{ mm}^2$, no centro da viga.

AVISO: não existe um sistema pré-definido de unidades dentro do *Abaqus*. Portanto, o usuário é responsável por garantir que valores corretos (coerentes!) sejam especificados. Sempre que possível, use unidades SI.

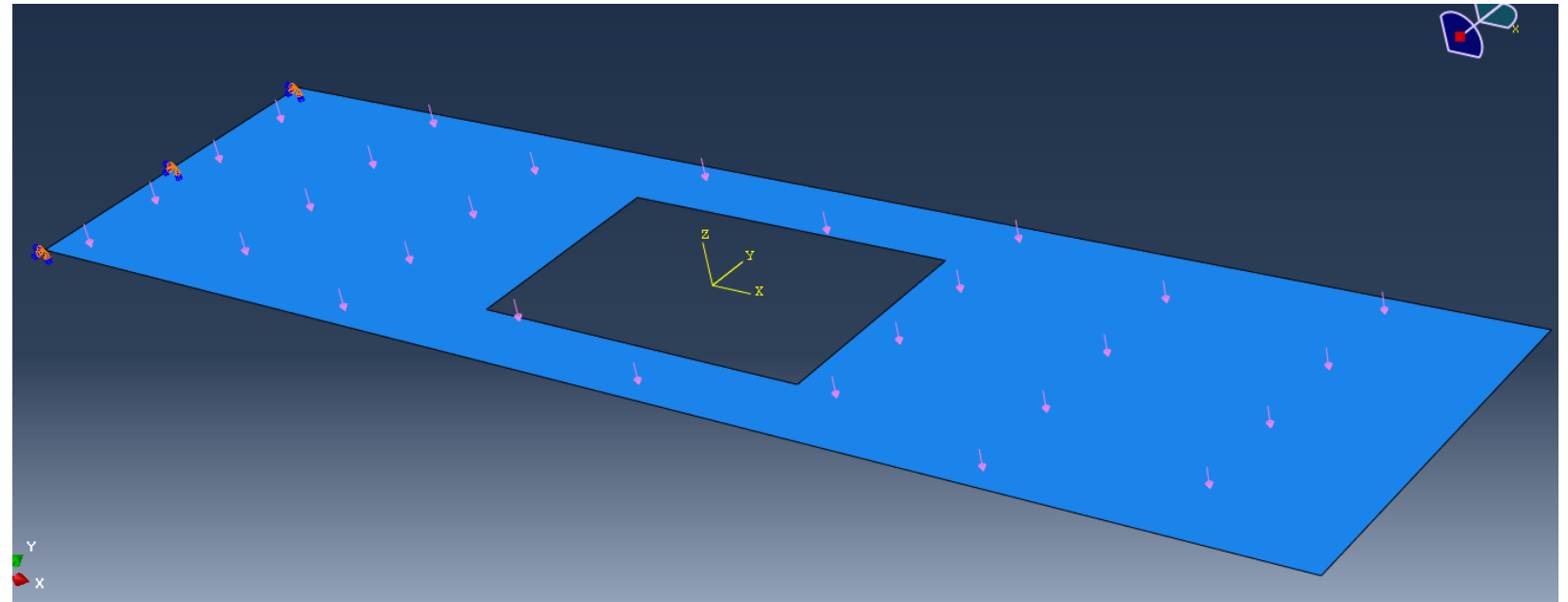



Construção do modelo: Pré processamento

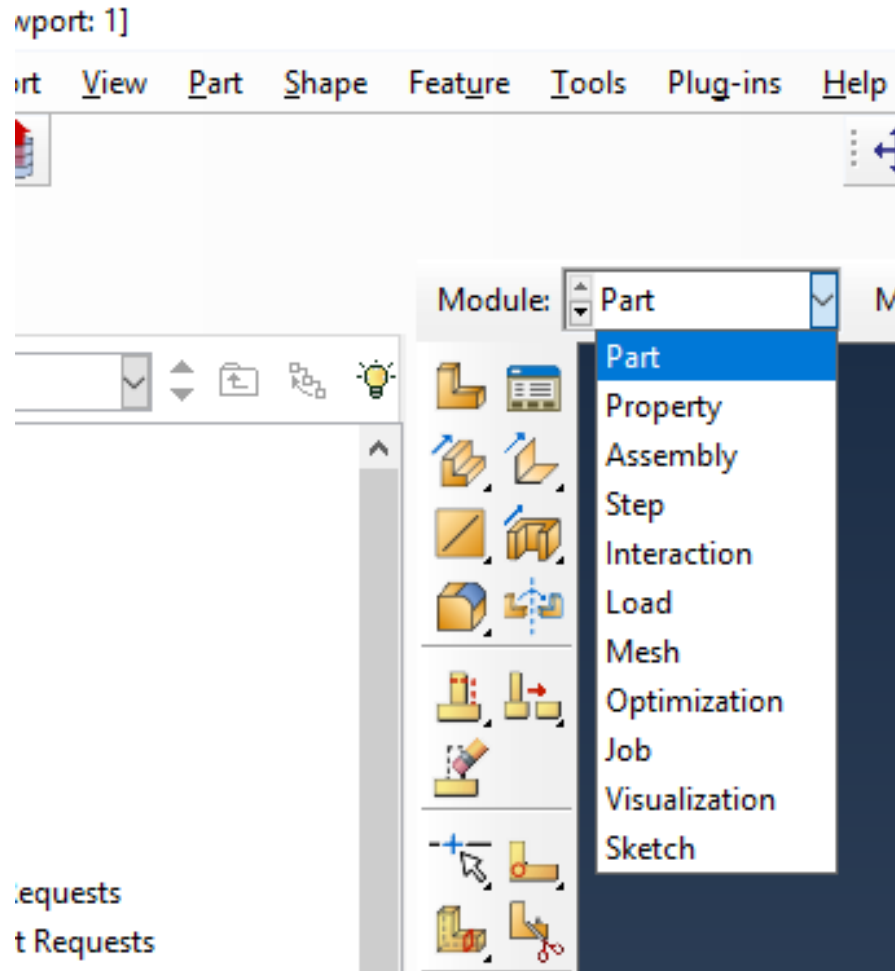

Passaremos pelos itens:

Part: desenho da geometria

Property: material e seção transversal

Assembly: Unir as partes

Step: Carregamento

Interaction: definição de contato

Load: definição de carregamento e condições de contorno

Mesh: malha de elementos finitos

Job: rodar o programa

Visualization: ver resultados



Na árvore do modelo, clique duas vezes em "Part" (ou clique com o botão direito em "Part" e selecione "Create").

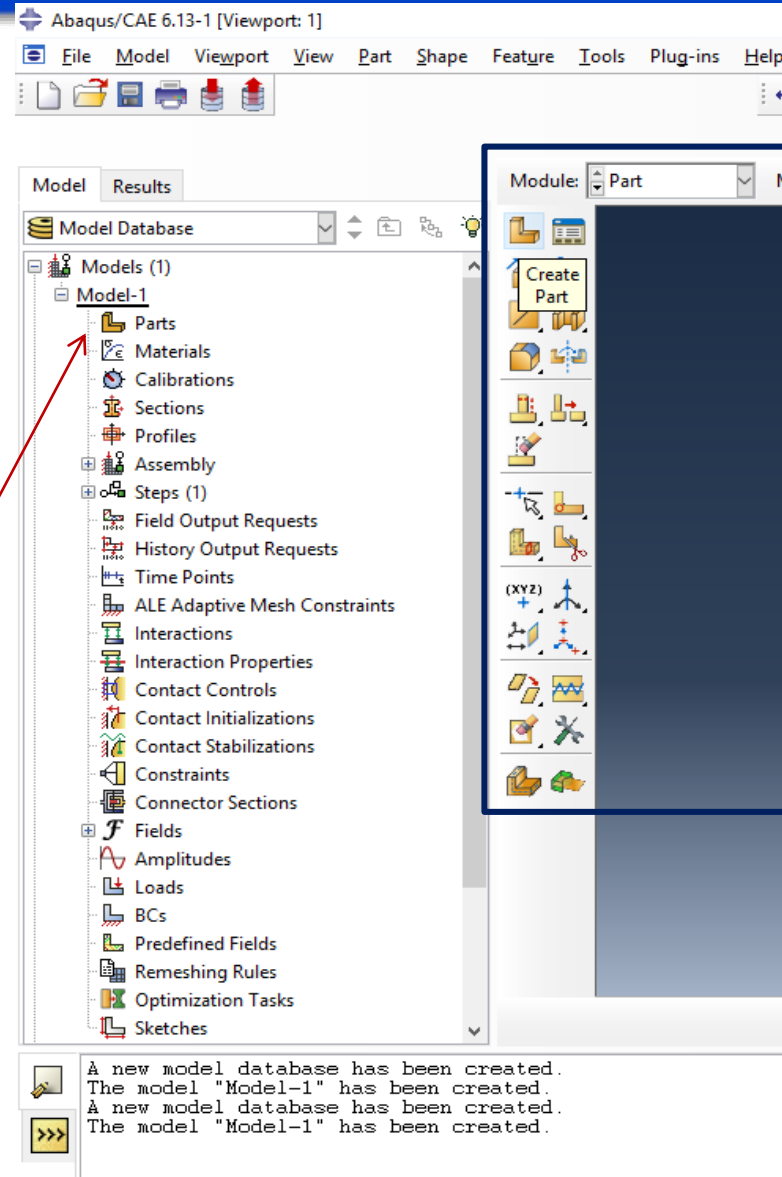
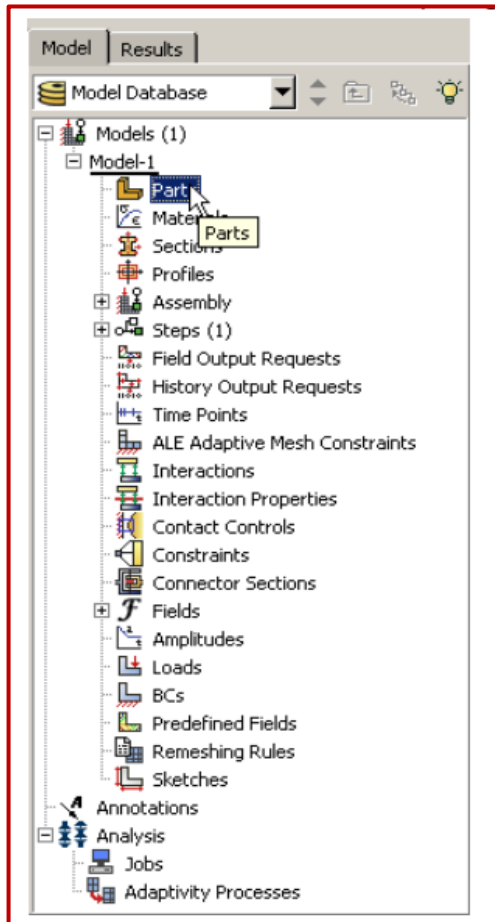

Ou, ainda, selecione "Part" em "Module" e "Create Part" na caixa de ajuda ao lado da área de trabalho (chamada de *Viewport* pelo Abaqus).

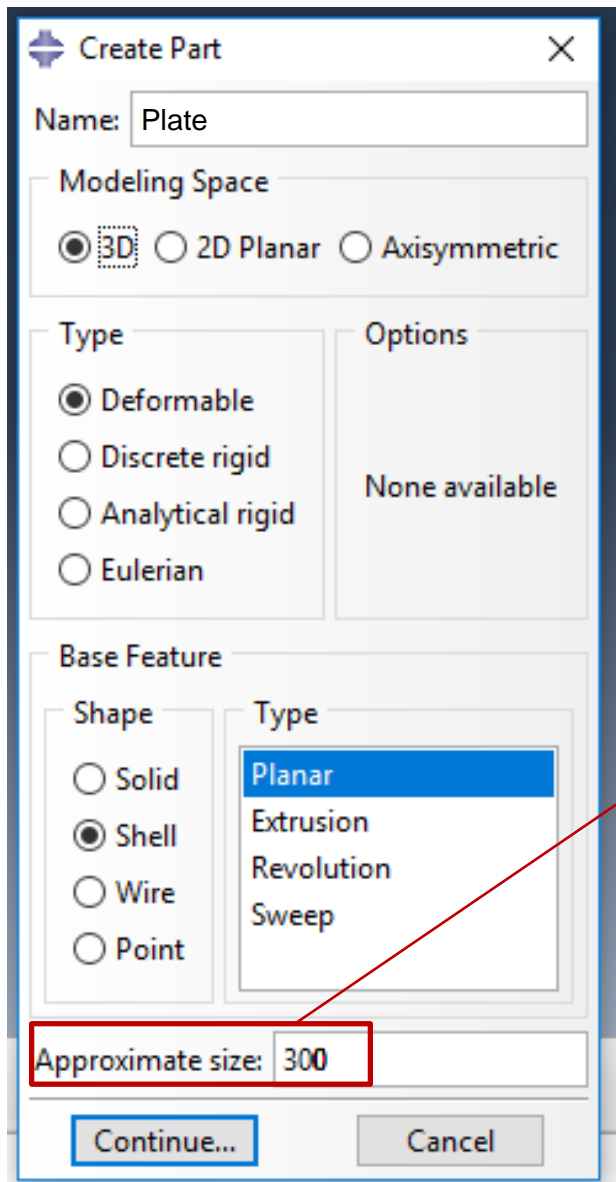

Nomeie a parte **Plate**.

Selecione as configurações um corpo tridimensional (Modeling space 3D) deformável (type deformable) a partir de uma casca plana (shape Shell e type Planar).

Approximate size: coloque 300 (Não é importante, determina o tamanho da grade a ser exibida). Clique "Continue..." e se abrirá a janela de "sketch"

A espessura de 2mm nos permite utilizar elementos bidimensionais de casca e, com isso, diminuir o tamanho do modelo e economizar tempo de processamento.

Clique Continue e aparecerá a janela de Sketch

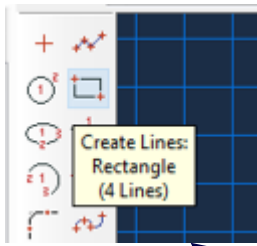

A caixa de commands para desenhar a geometria é intuitiva.
Use a opção de retângulo.

Você pode usar o grid e o mouse (veja coordenadas no canto esquerdo superior)

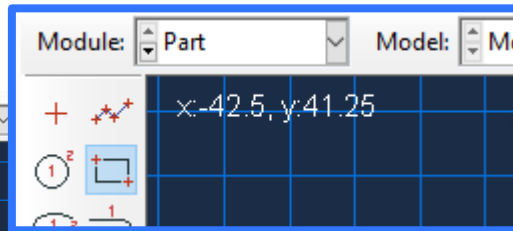

Você pode digitar as coordenadas (veja barra de comandos no canto esquerdo inferior da viewport)

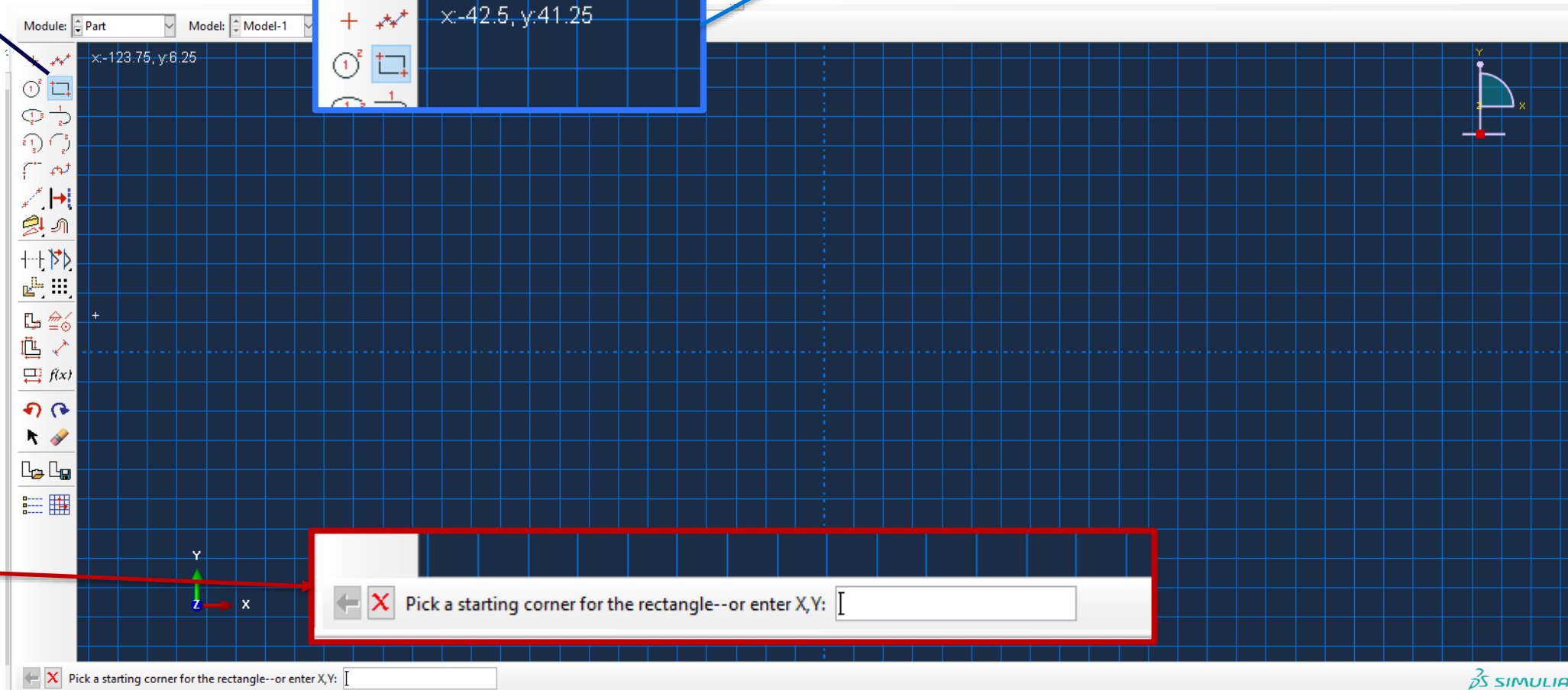



Faça dois retângulos: 200x50 para viga e, centrado na viga, 50x30 para o furo. O grid facilita seu desenho. Não há necessidade de colocar as cotas (estão aqui por motivos didáticos). A geometria é definida pelas linhas amarelas

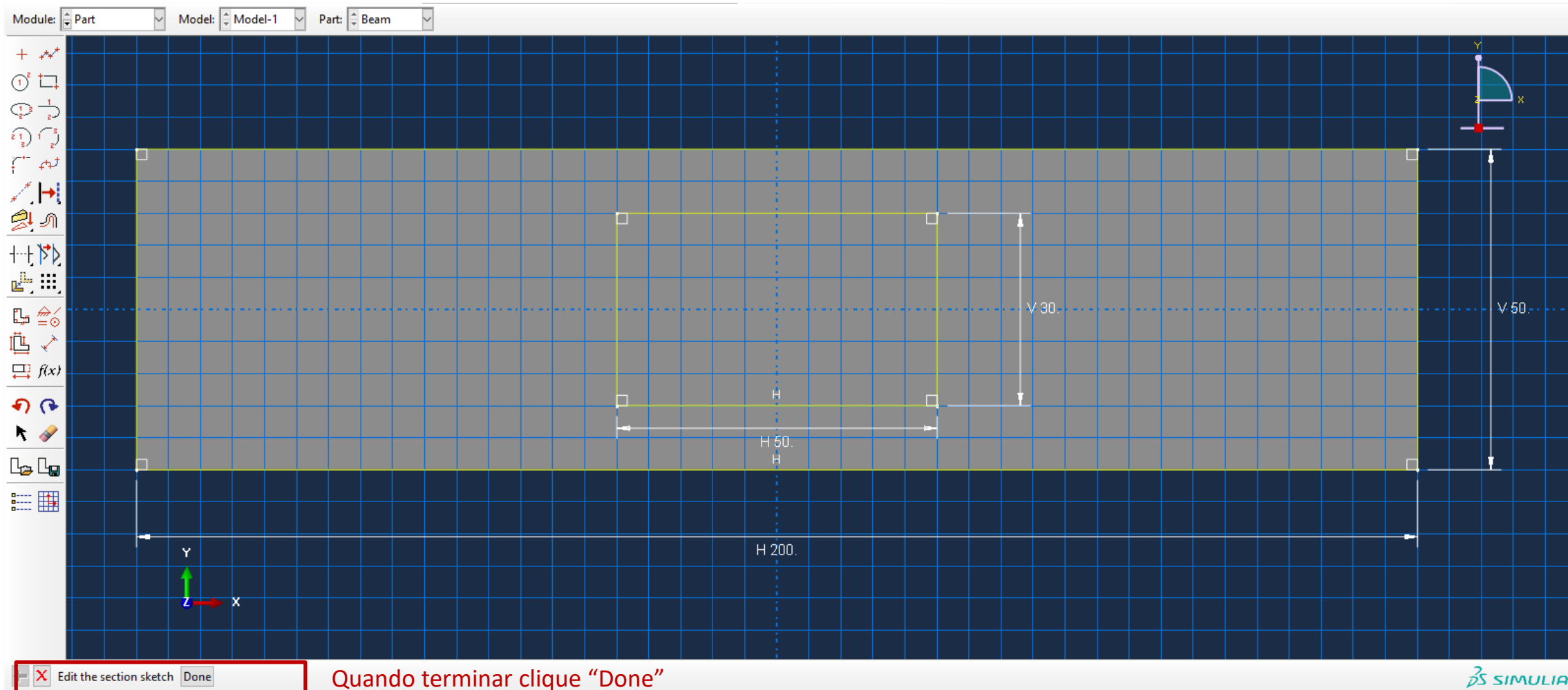



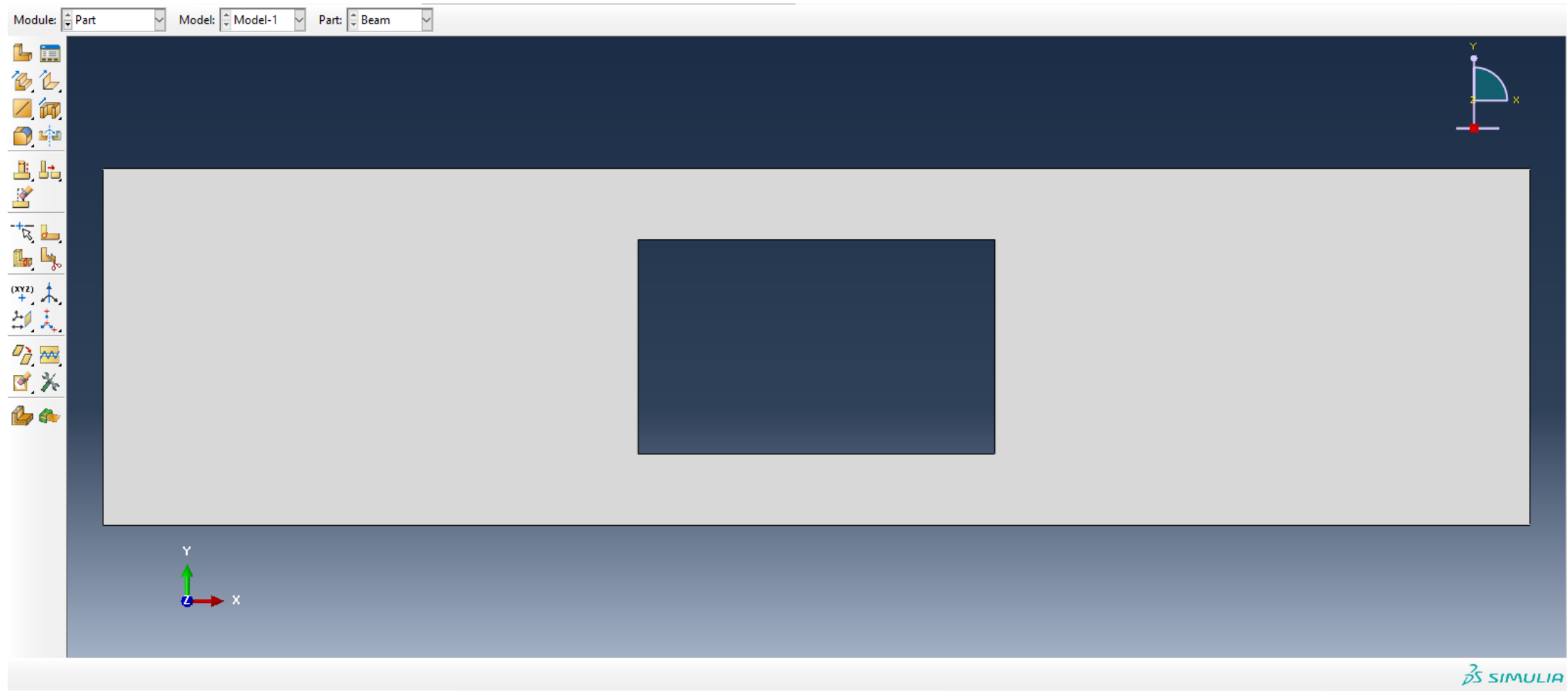

Este é seu modelo até o momento. Essa geometria não tem material nem seção. Esses são nossos próximos passos.





Várias ferramentas estão disponíveis na barra de ferramentas para ajudá-lo a examinar seu modelo.

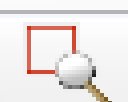

-  Pan view
-  Rotate view
-  Magnify view
-  Toolbox view
-  Autofit view

Você pode deixar mais fáceis alguns outros ícones importantes:

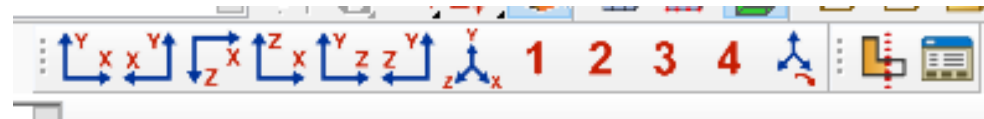

Basta ir em View/Toolbars e clicar na opção Views:

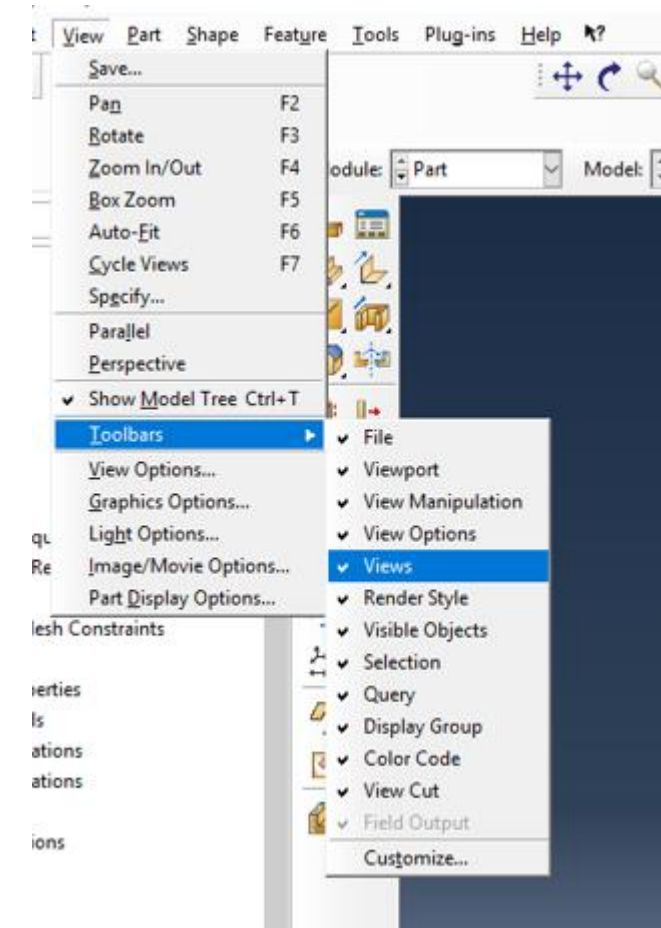

Experimente com cada uma dessas ferramentas até ficar confortável com elas.

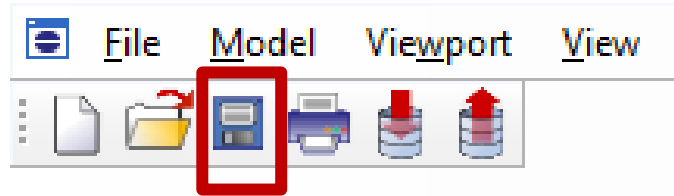

Não precisamos lembrar você de salvar o modelo de vez em quando, obviamente...

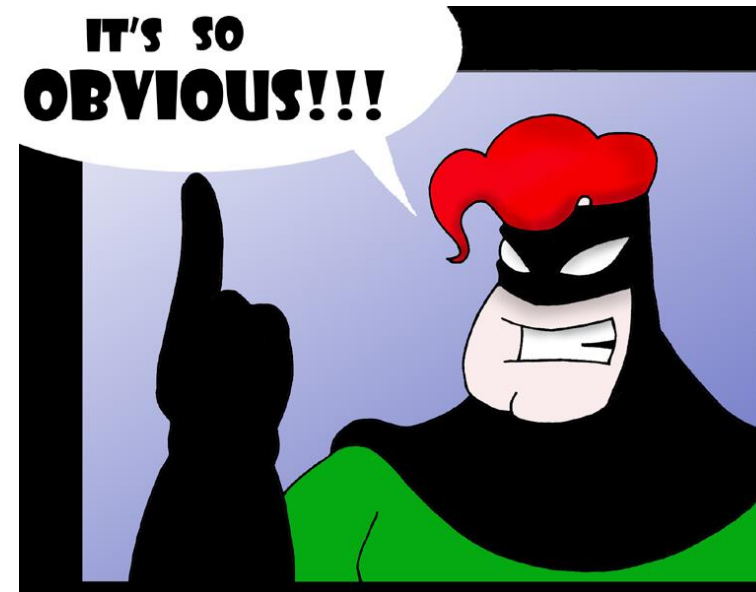

Definição do material

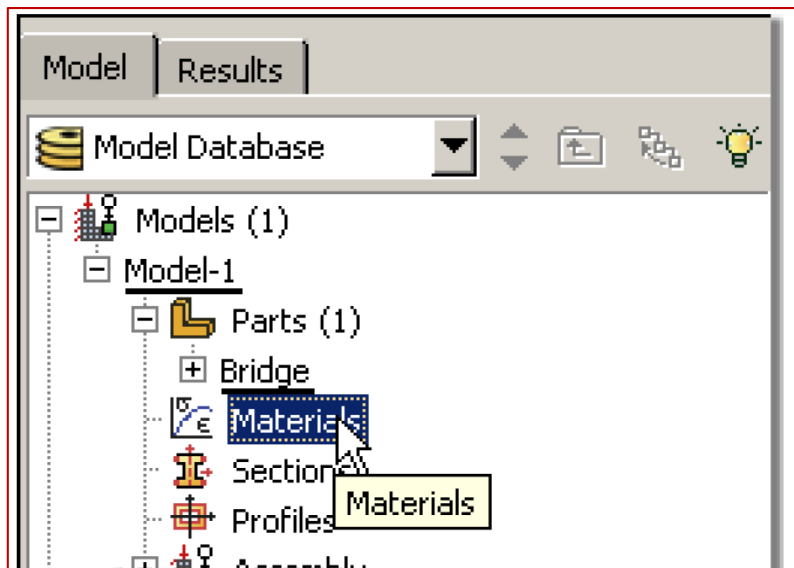

Clique duas vezes em
“Materials” na árvore ou, ainda,
selecione "Part" em “Module” e
“Create Materials” na caixa de
ajuda ao lado da *Viewport*.



Edit Material

Name: Steel

Description: Material da viga

Material Behaviors

General Mechanical Thermal Electrical/Magnetic Other

Density
Depvar
Regularization
User Material
User Defined Field
User Output Variables

OK Cancel

Edit Material

Name: Steel

Description: Material da viga

Material Behaviors

Density

General Mechanical Thermal Electrical/Magnetic Other

Density

Distribution: Uniform

Use temperature-dependent data

Number of field variables: 0

Data

	Mass Density
1	7.8e-9

Nomeie o novo material e dê uma descrição (Steel);
Clique na guia "General" → "Density"
Density (7.8e-9)
Clique "OK"

Porque esse valor





Edit Material

Name: Steel
Description: Material da viga

Material Behaviors

Density

General Mechanical Thermal Electrical/Magnetic Other

Elasticity ▶ Elastic

Plasticity ▶ Hyperelastic

Damage for Ductile Metals ▶ Hyperfoam

Damage for Traction Separation Laws ▶ Low Density Foam

Damage for Fiber-Reinforced Composites ▶ Hypoelastic

Damage for Elastomers ▶ Porous Elastic

Deformation Plasticity ▶ Viscoelastic

Damping

Expansion

Brittle Cracking

Egs

Viscosity

Edit Material

Name: Steel
Description: Material da viga

Material Behaviors

Density

Elastic

General Mechanical Thermal Electrical/Magnetic Other

Elastic

Type: Isotropic ▼ Suboptions

Use temperature-dependent data

Number of field variables: 0

Moduli time scale (for viscoelasticity): Long-term ▼

No compression

No tension

Data

	Young's Modulus	Poisson's Ratio
1	210000	0.27

OK Cancel

Clique na guia "Mechanical" → "Elasticity" → "Elastic"
Definir o Módulo de Young (210000) e Coeficiente de Poisson (0.27)



Definição da seção

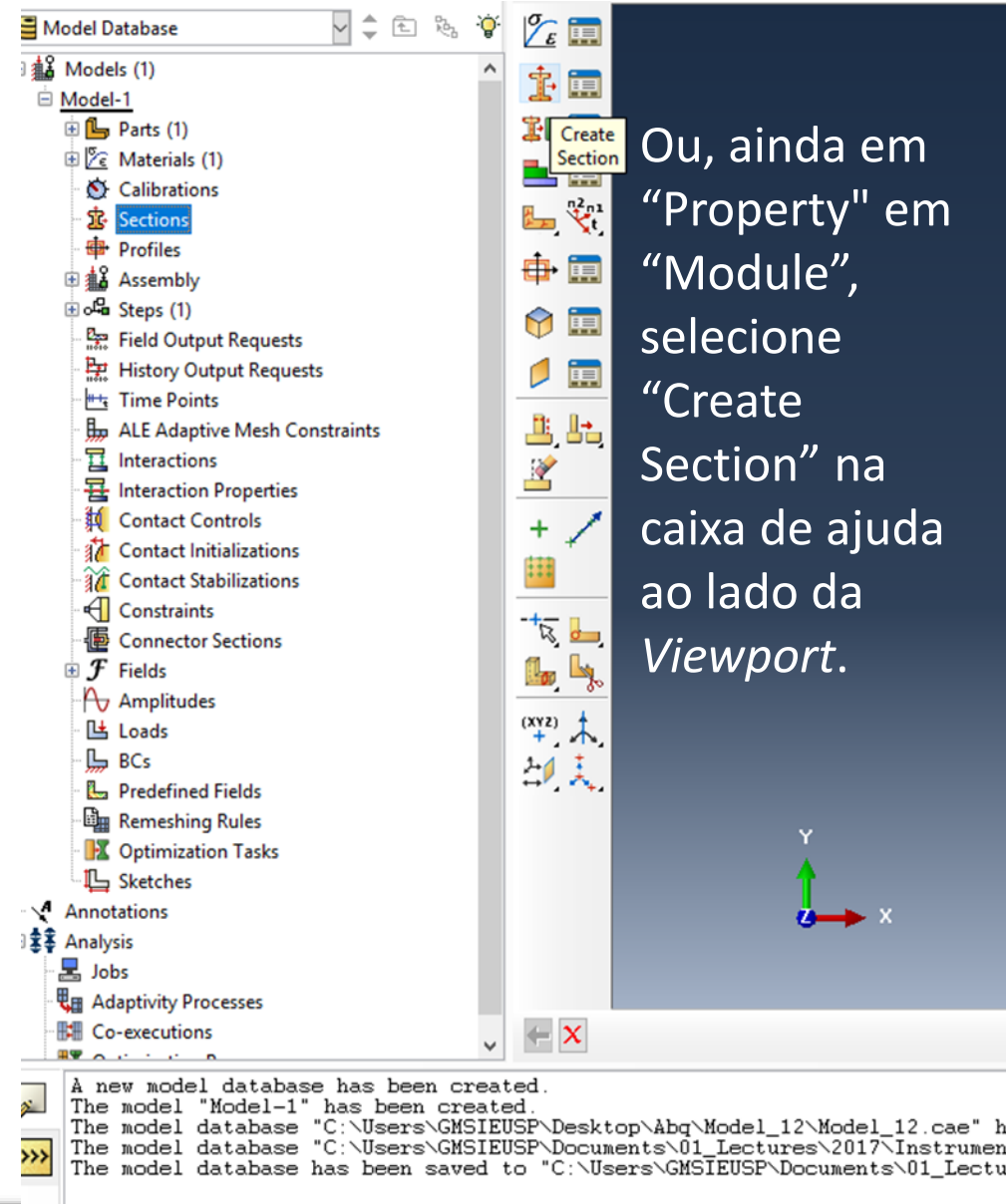
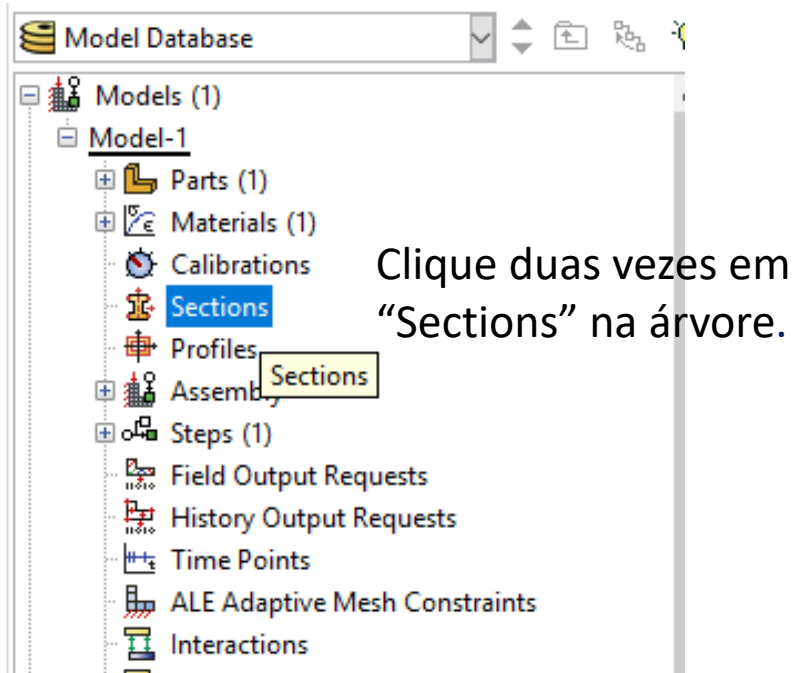

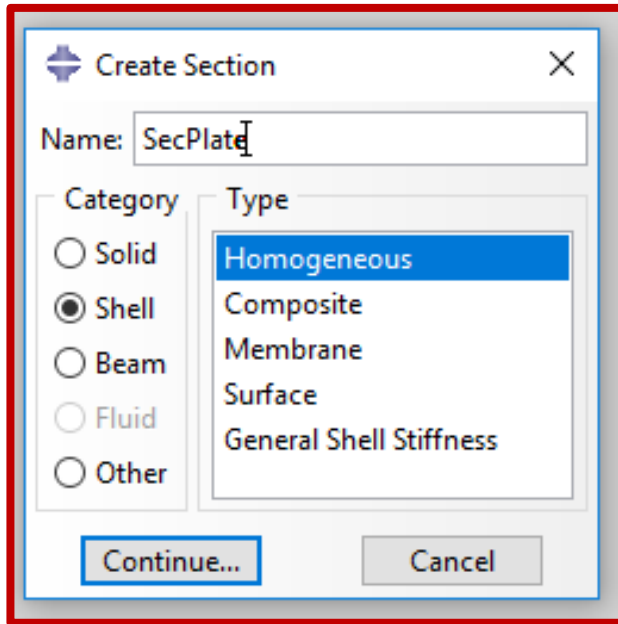

Dê um nome à seção, selecione “Shell” e “Homogeneous”. “Continue...” abrirá a janela abaixo.

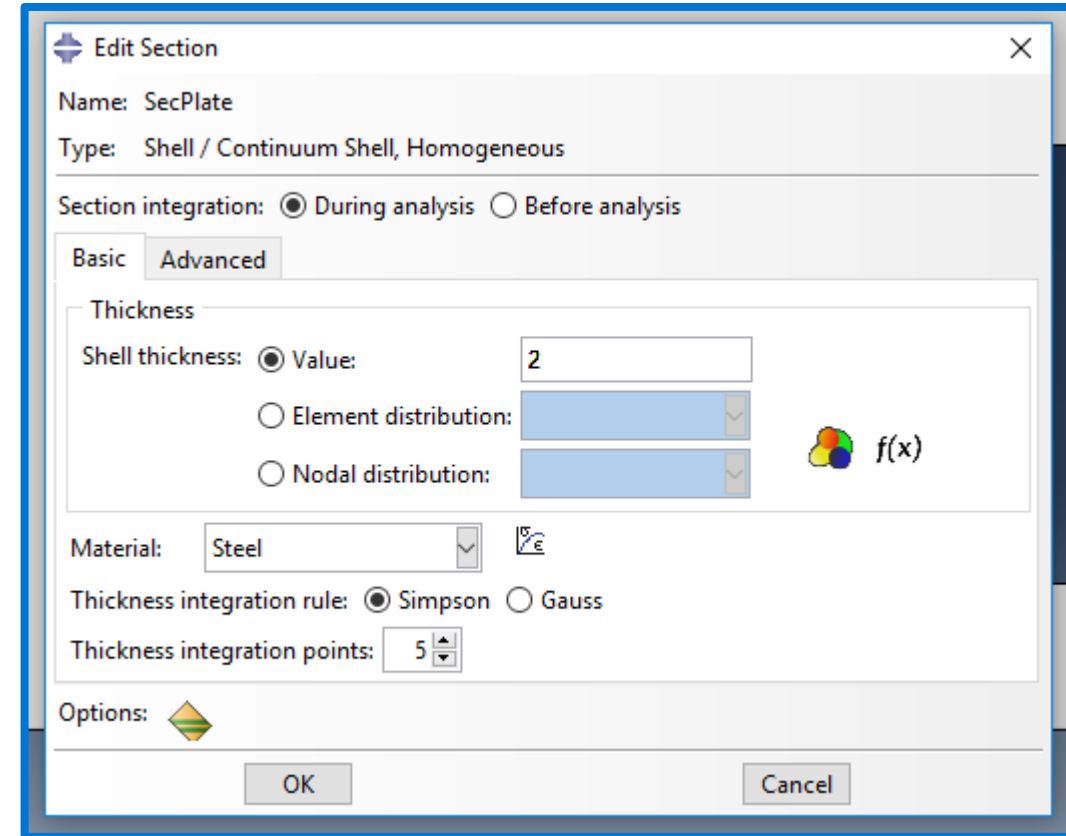

Espessura 2mm.
Material “Steel” (provavelmente já estará selecionado, pois é o único que criamos).
Demais parâmetros default.
Clique “OK”.

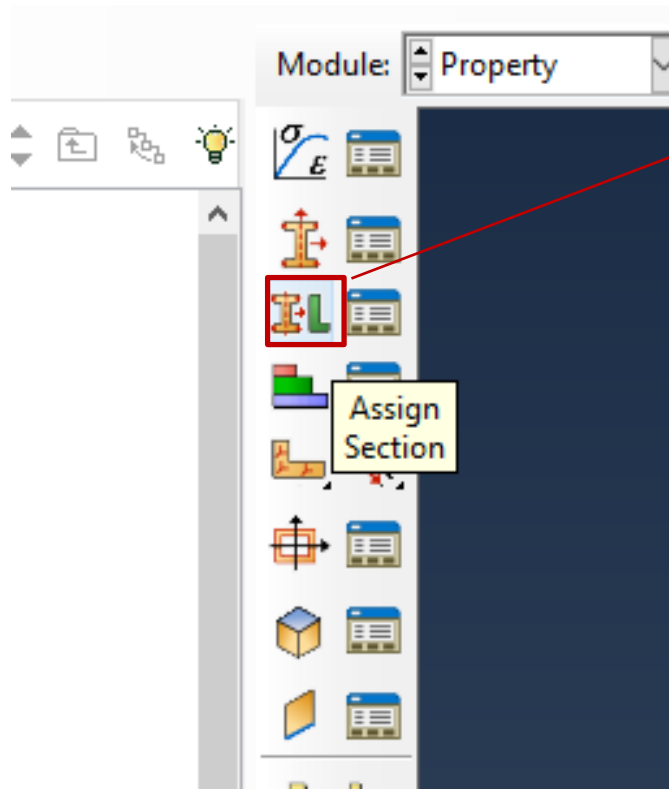

Agora você deve atribuir propriedade à viga que você desenhou!

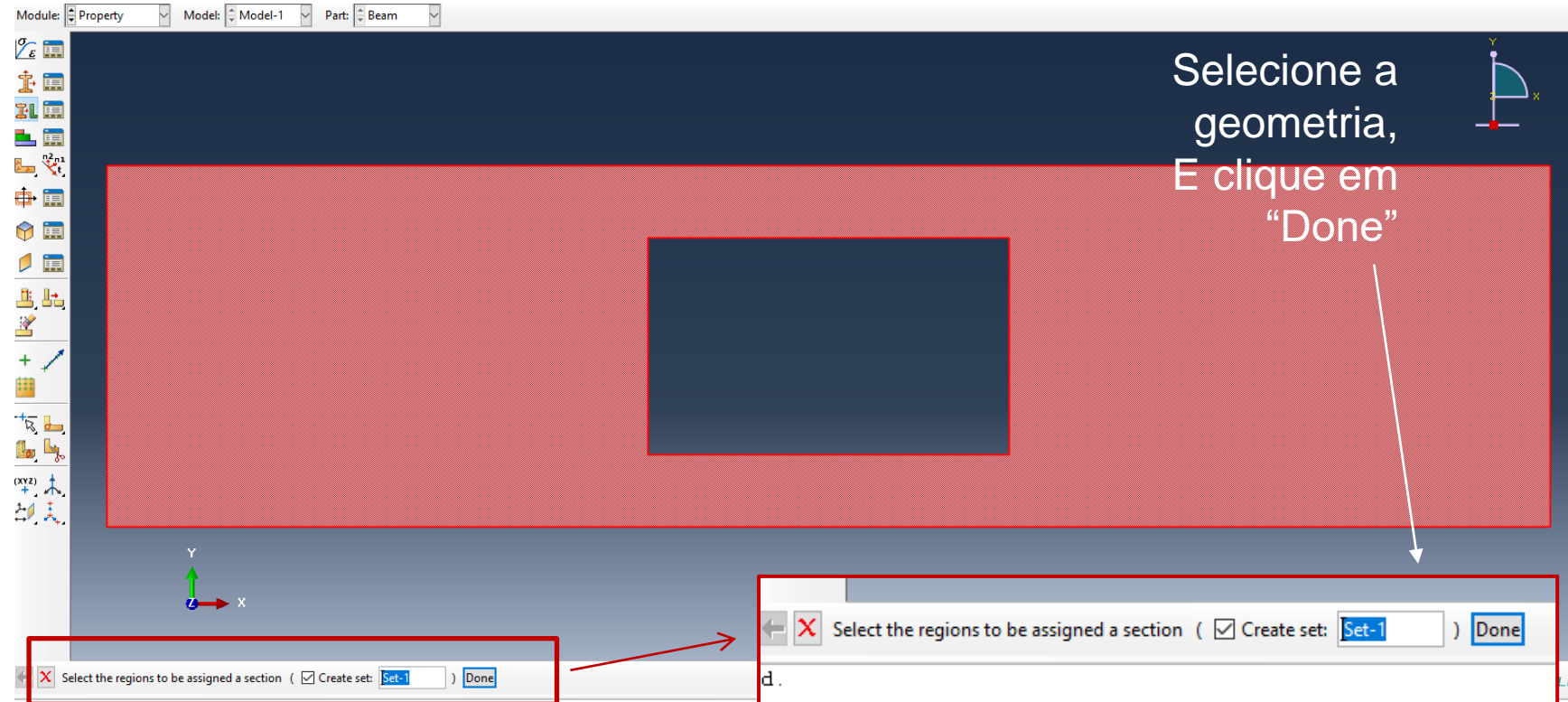

Selecione a geometria, E clique em "Done"

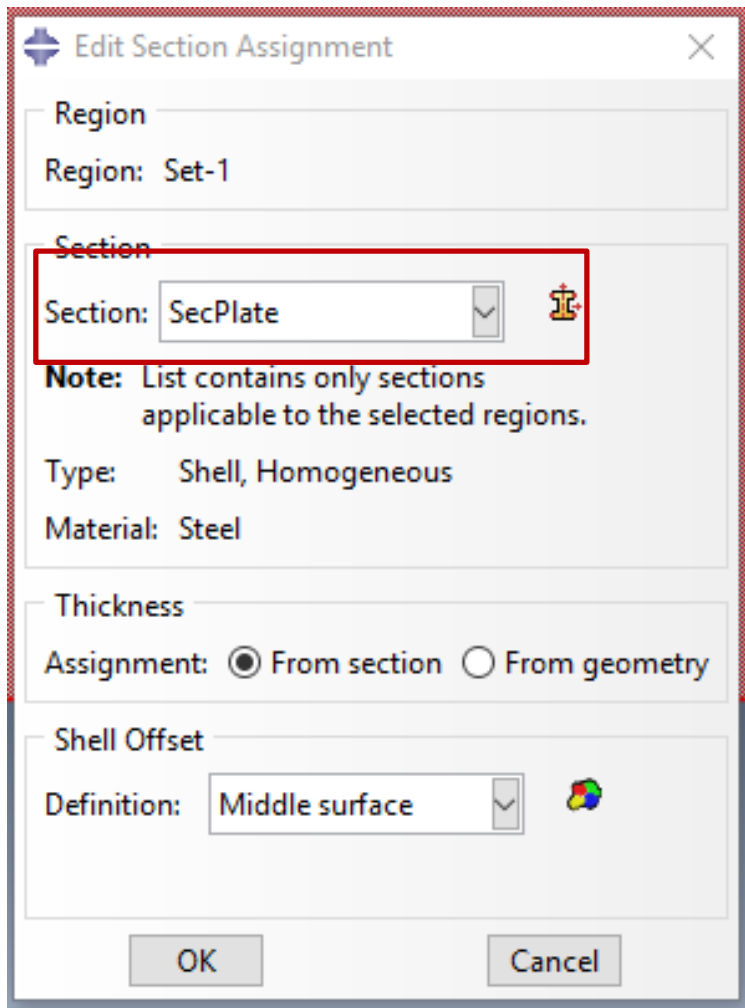

Clique "OK".

Provavelmente a seção "SecPlate" já estará selecionada (inclui a geometria de 1mm com material aço). Se não estiver, clique no ícone e selecione.

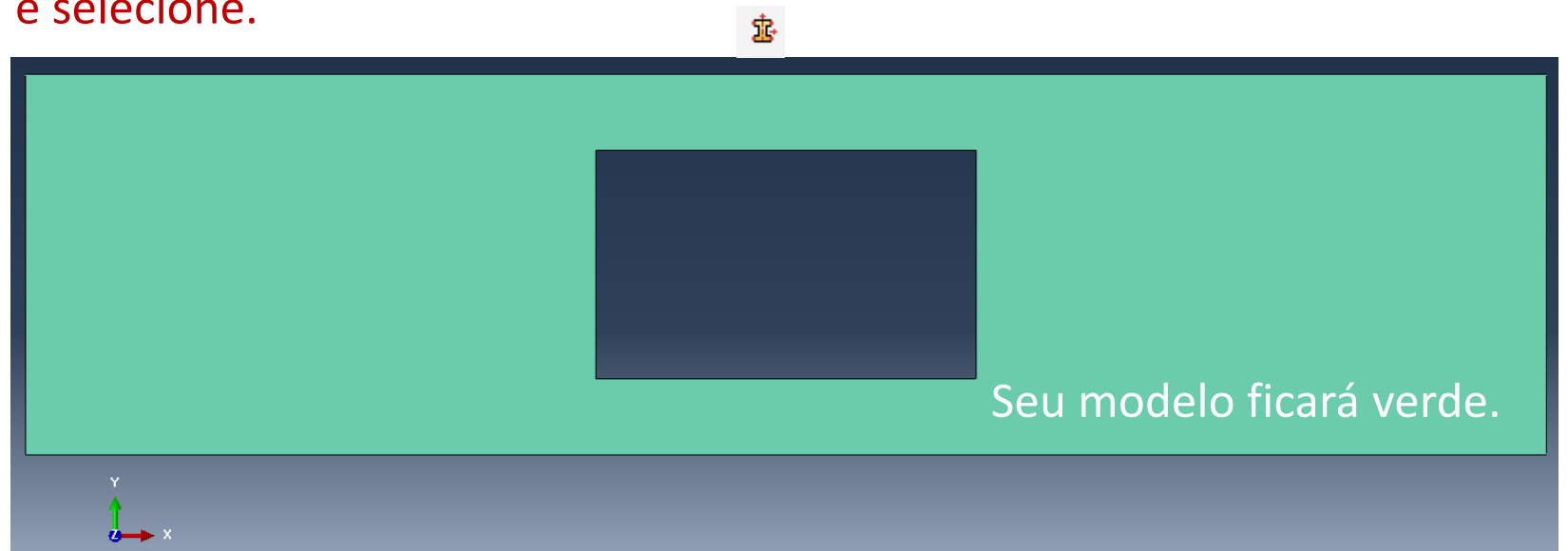

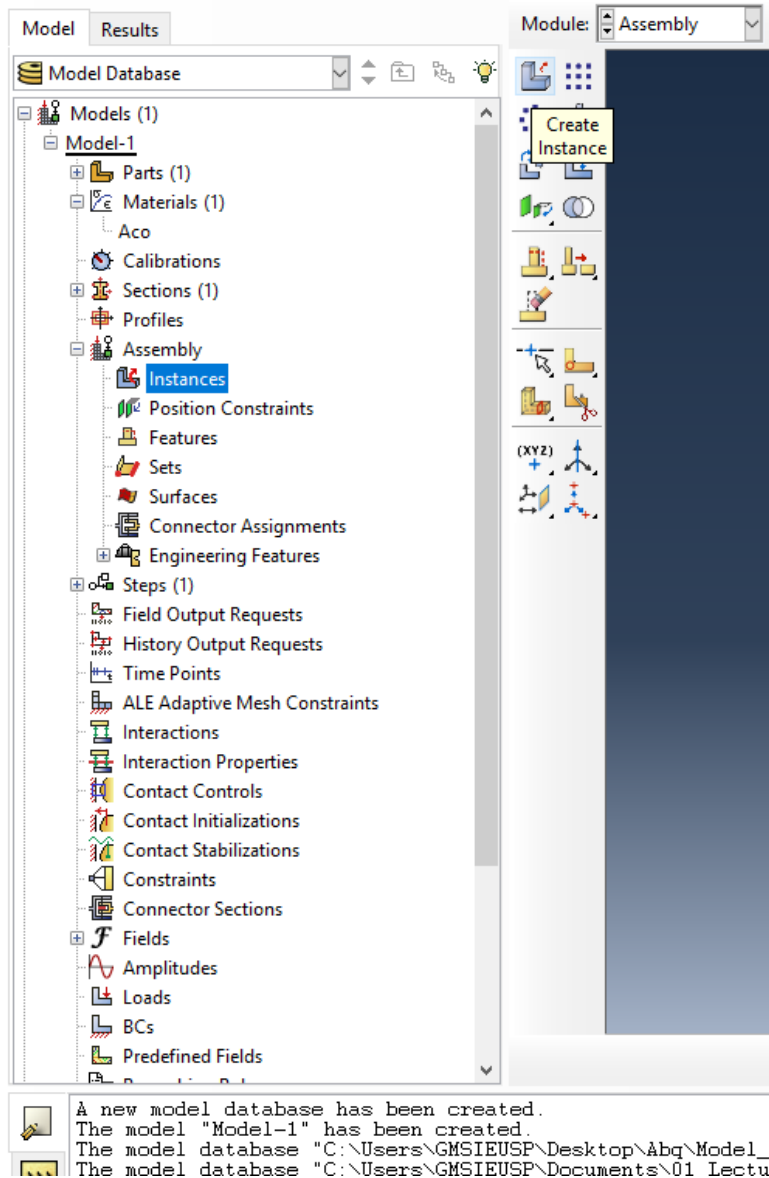

Observação importante: Esta etapa é mais útil quando o modelo é formado por várias *partes* (“Part”), e você deve uni-las para criar uma estrutura única. Porém, é uma etapa que não pode ser pulada quando você tem somente uma parte, como nosso caso.

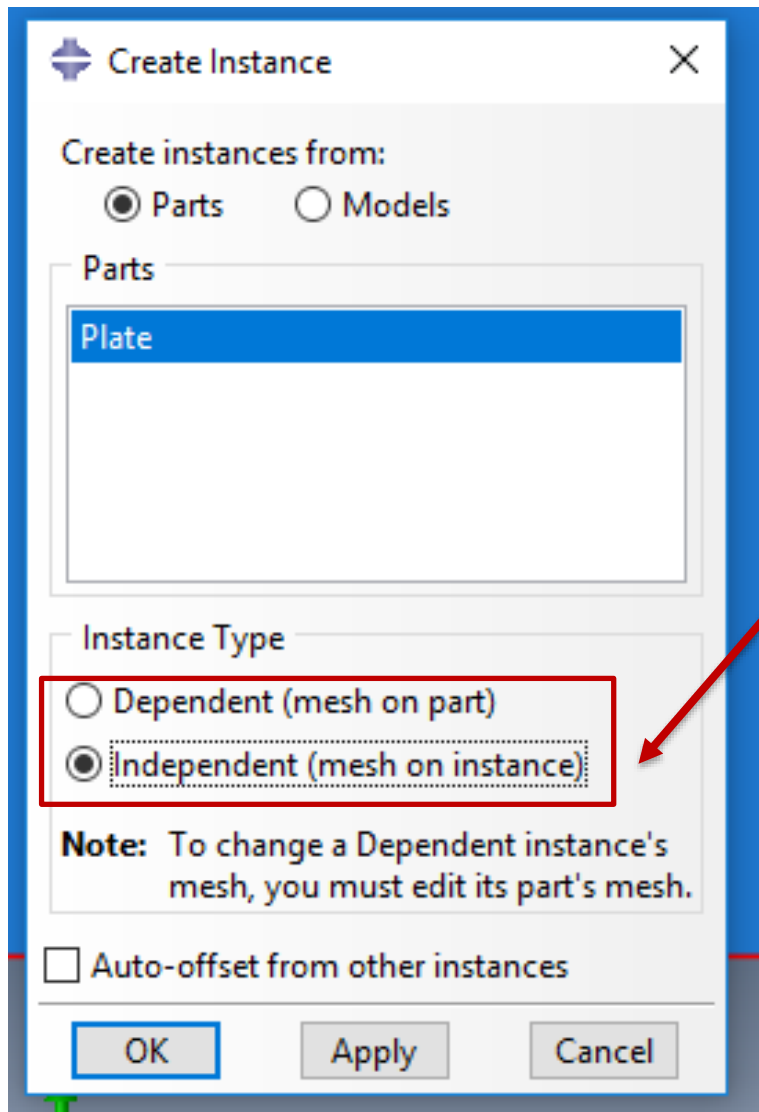

Basta dar duplo clique em “Instances”, dentro de “Assembly” na árvore ou “Create Instance” no painel de ajuda no ViewPort.
Selecione “Independent” em “Instance Type”
Clique em “Apply” e “Cancel”.

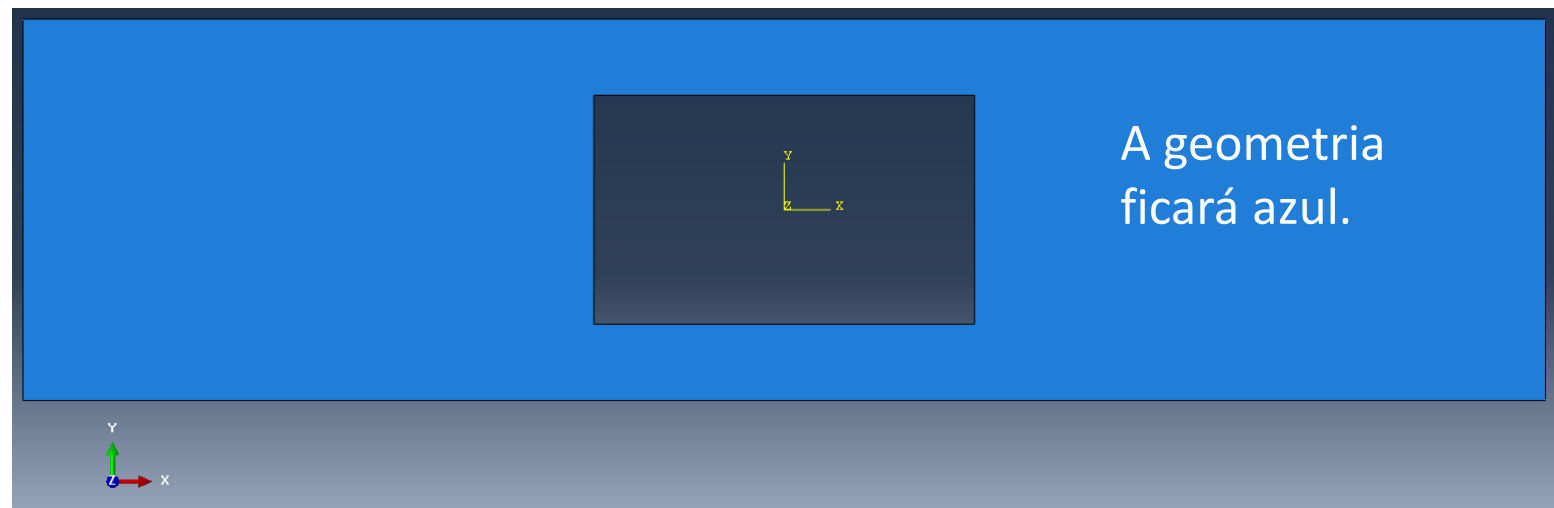



- Agora que você criou sua parte, você pode mover para o módulo **STEP** para definir suas etapas de análise. Para o tutorial da sua placa em balanço, a análise consistirá em duas etapas:
 1. Um passo inicial, no qual você aplicará uma condição de contorno que restrinja uma extremidade da viga;
 2. Um passo de análise estática geral, no qual você aplicará uma carga de pressão na parte superior da viga.
- ABAQUS/CAE gera automaticamente o passo inicial, mas você deve usar o módulo STEP para criar a etapa de análise você mesmo. O módulo STEP também permite que você solicite saída para qualquer etapa na análise.

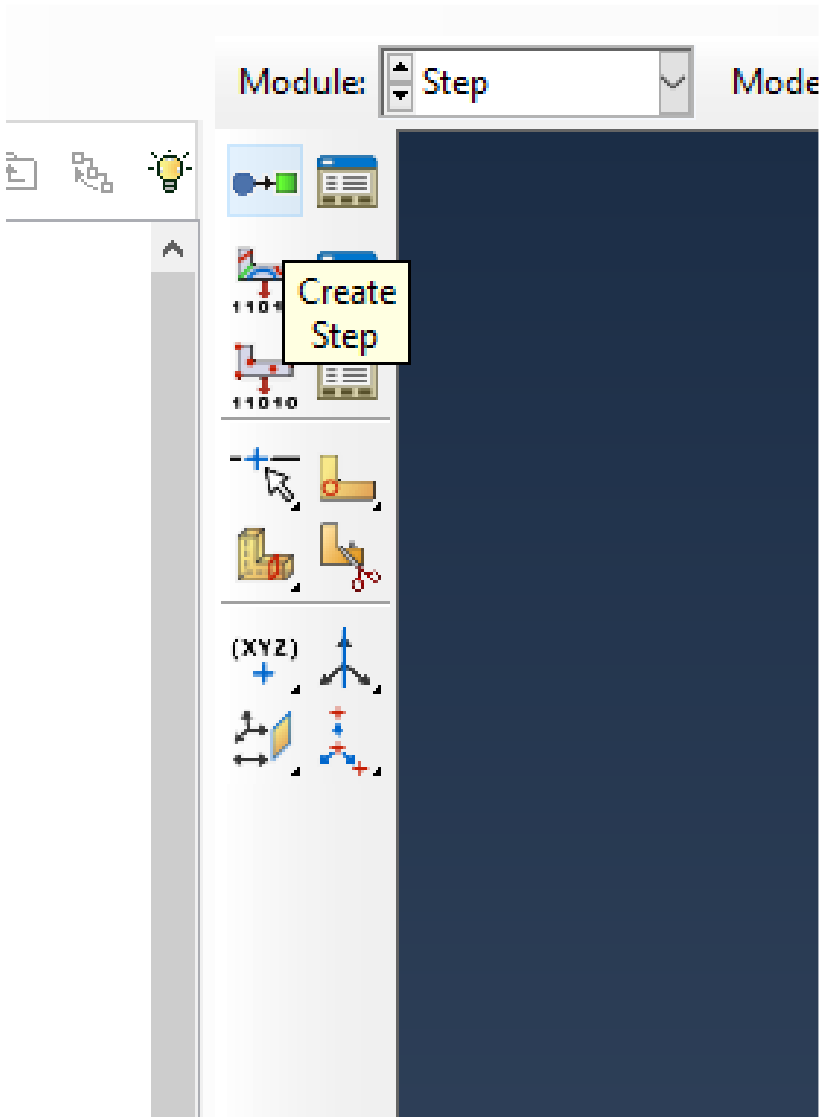

Em “Step” – acho que você já entendeu que pode usar diretamente a árvore do modelo ou o painel ao lado do ViewPort em cada uma das etapas... (e já escolheu seu caminho favorito). 😊😊

Abre-se a caixa de diálogo **Create Step**, com uma lista de todos os procedimentos gerais (por default considera análise estática, mas iremos modificar) e um nome padrão do STEP *Step-1*. Os procedimentos (procedure type) são aqueles que podem ser usados para analisar a resposta linear ou não-linear. No próximo slide iremos modificar os parâmetros necessários.

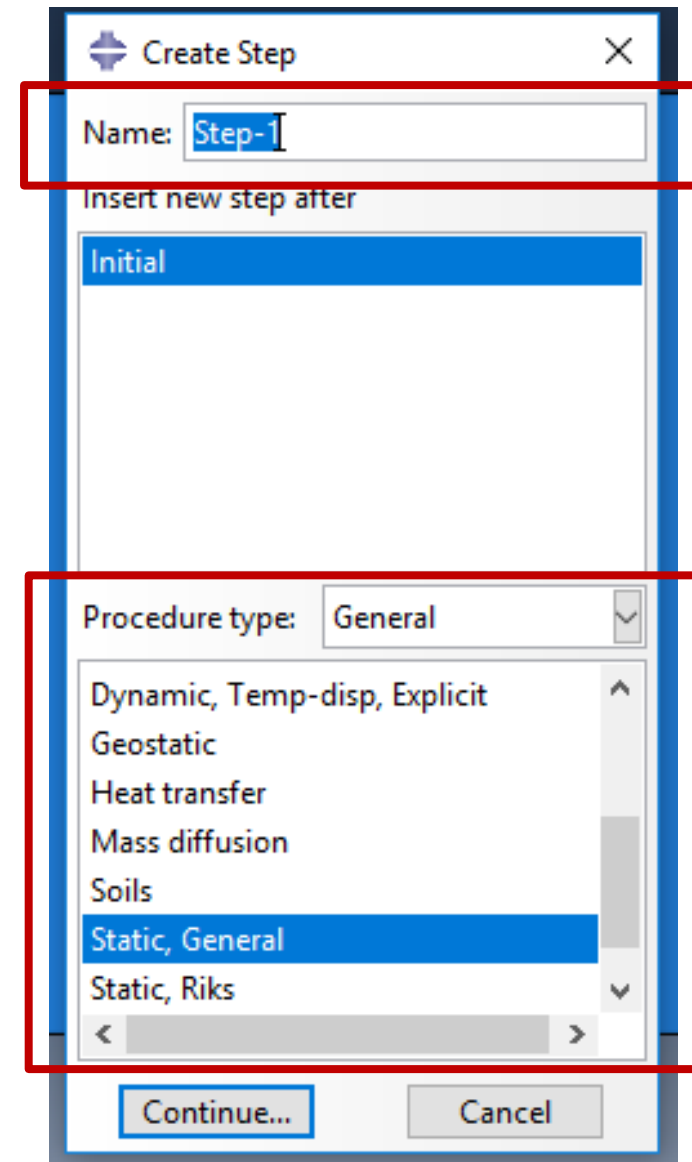



Dê um nome ao step
(PlateLoad);

Na lista de *Procedure type*,
disponível na caixa de
diálogo *Create Step*,
selecione *General* (se
ainda não estiver
selecionado), *Dynamic
Explicit* e clique em
Continue...

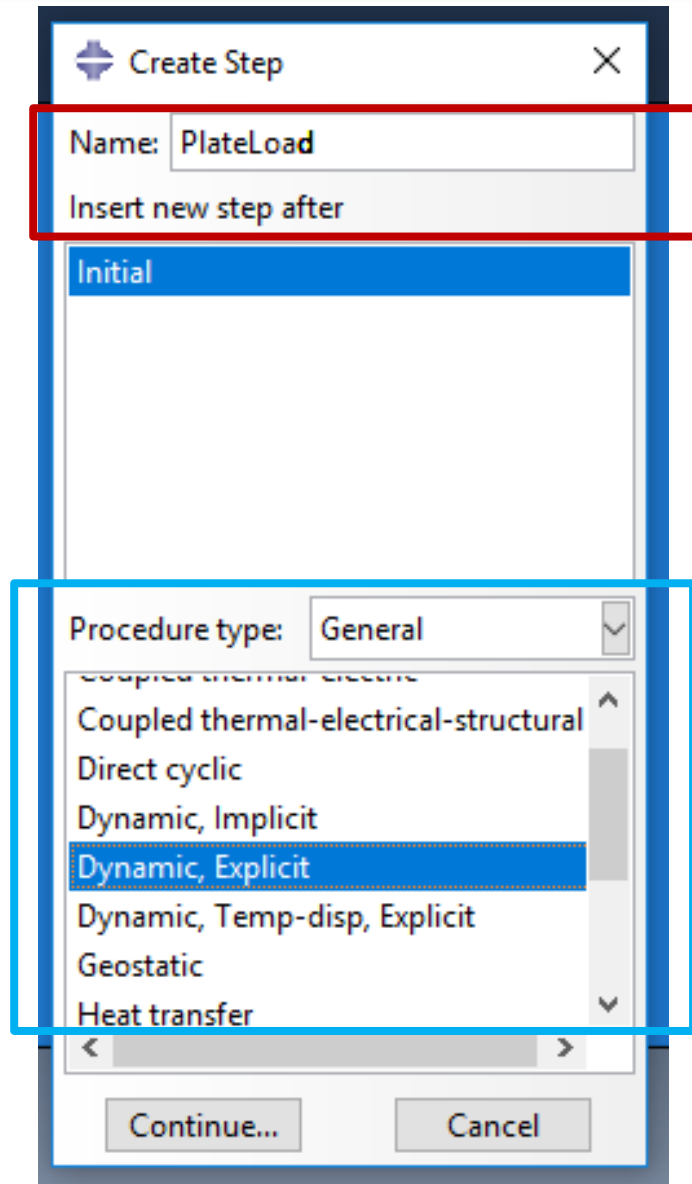



A caixa de diálogo **Edit Step** é exibida.
Em **Description**, digite “Pressão senoidal de 0.02 MPa ”.
Time period é o tempo total de análise. Usaremos 0.1s.
O default é de 1s.
Nlgeom off – não consideraremos efeitos de grandes deslocamentos da geometria.

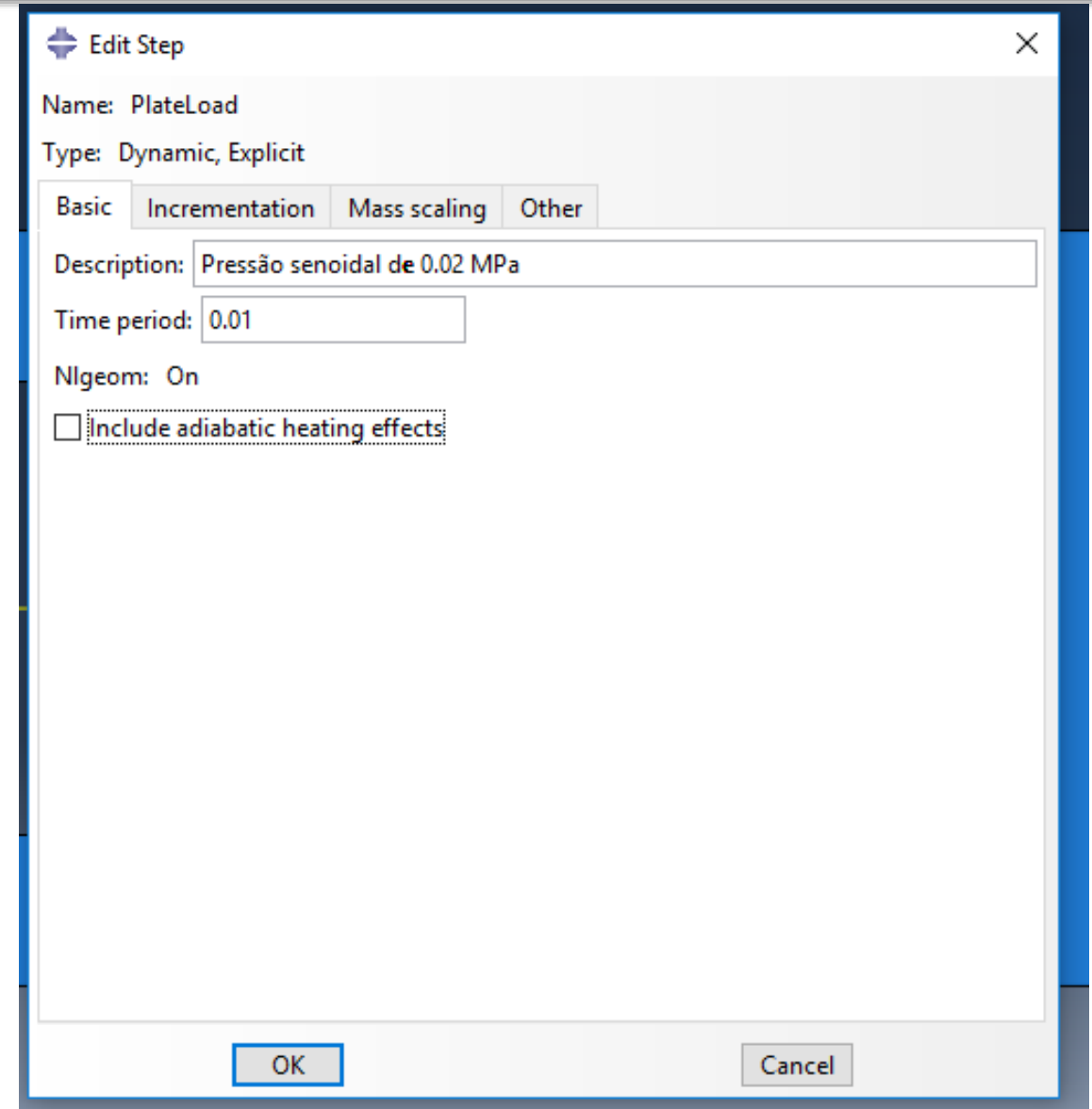



Clique na guia **Incrementation** e aceite as configurações padrão de incremento de tempo.

Clique na última guia (**Other**) para visualizar seus conteúdos; você pode aceitar os valores padrão fornecidos para a etapa.

Clique em OK para criar a etapa e sair da caixa de diálogo **Edit Step**

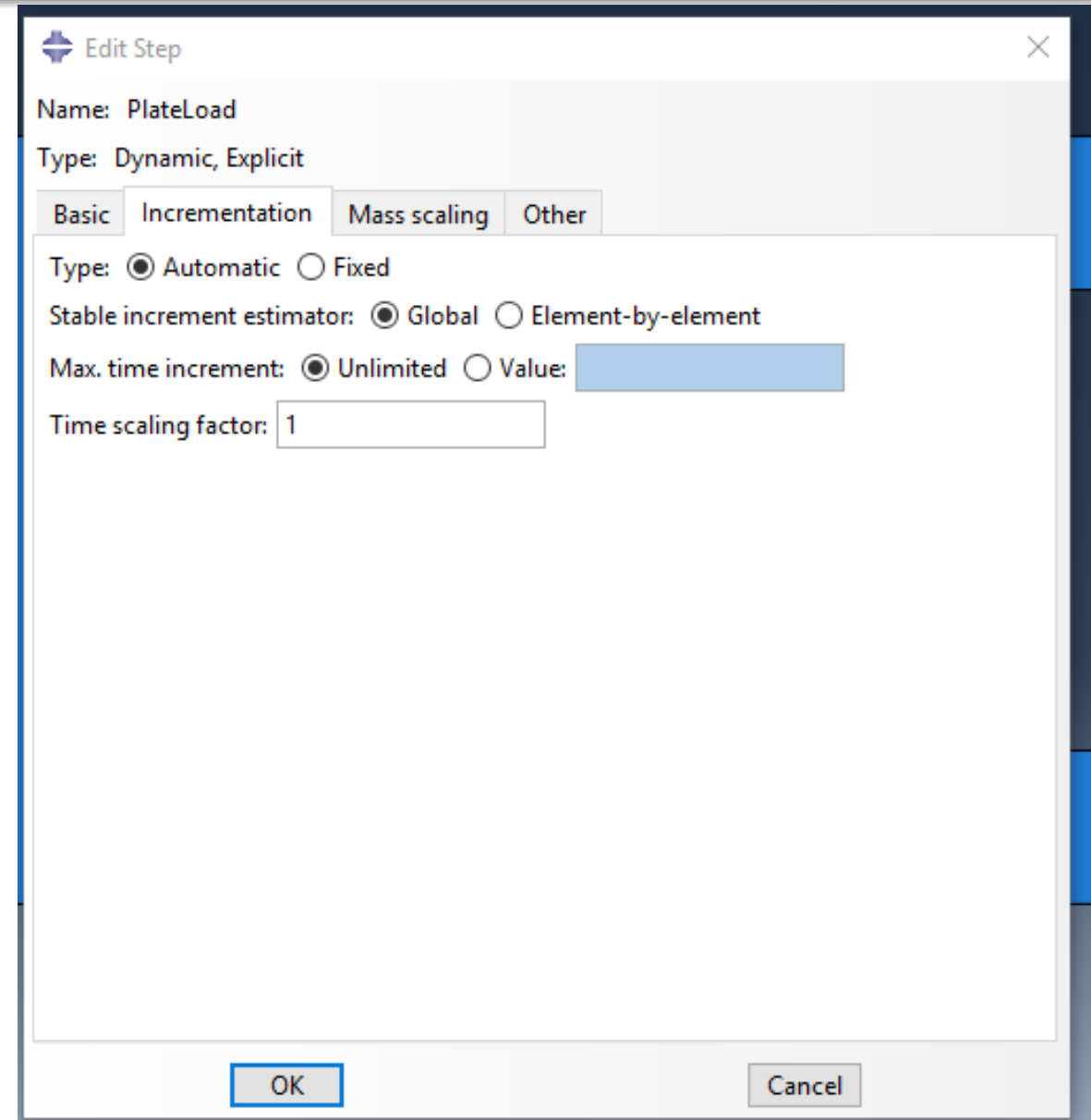

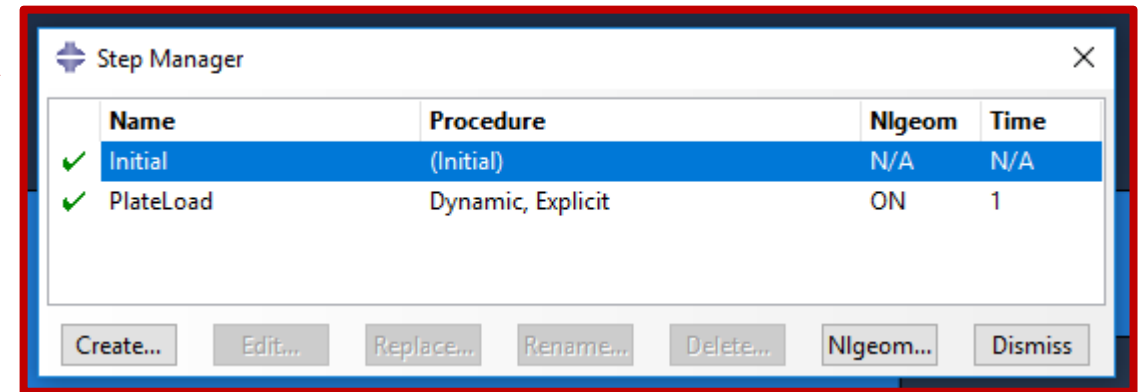
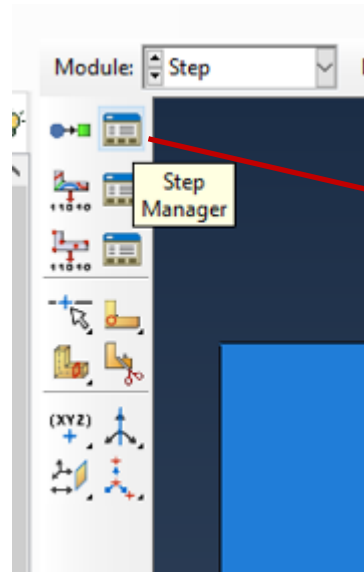
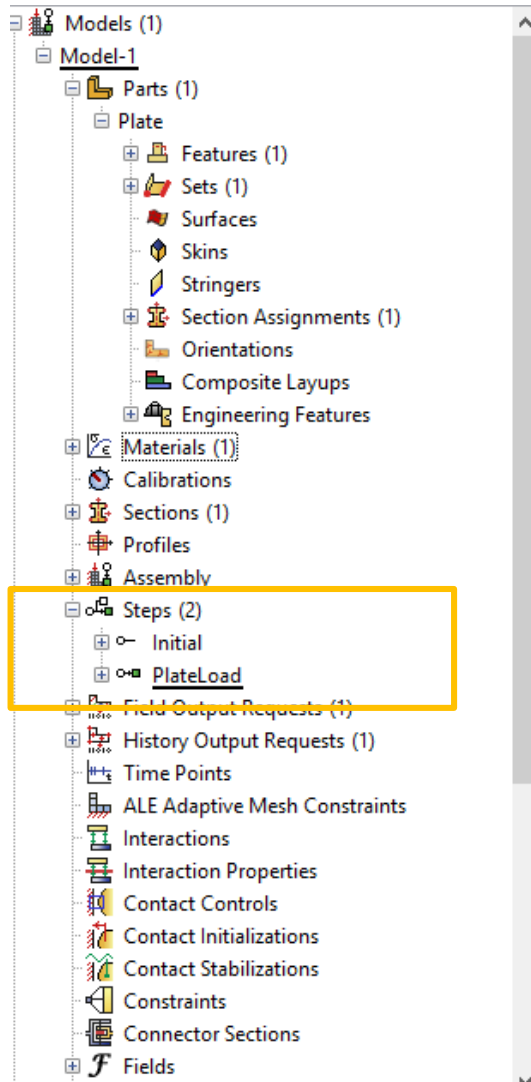

Veja que, na árvore e na barra de ajuda, em Steps, podemos visualizar os dois *steps da análise*, o “Initial”, e o recém criado “PlateLoad”



- Quando você envia seu *Job* para análise (calma, faremos mais adiante...), o software escreve os resultados da análise em um banco de dados de saída. Quando você cria um STEP, ABAQUS/CAE gera uma solicitação de saída padrão para o step. Para cada etapa que você criar, você pode usar o ***Field Output Requests Manager*** e o ***History Output Requests Manager*** para fazer o seguinte:
 - Selecione as variáveis que ABAQUS irá escrever no banco de dados de saída.
 - Selecione os pontos de seção para os quais o ABAQUS irá gerar dados.
 - Selecione a região do modelo para a qual o ABAQUS irá gerar dados.
 - Mude a frequência na qual o ABAQUS irá gravar dados no banco de dados de saída.

- No menu principal, selecione *Output* → *Field Output Requests* → *Manager*:

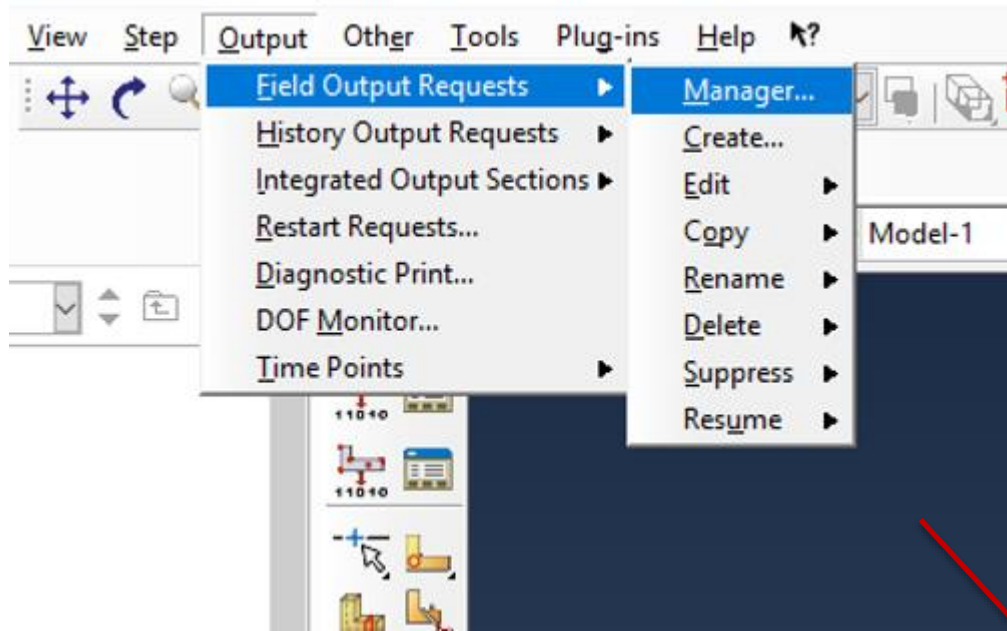

- Ou na árvore, selecione

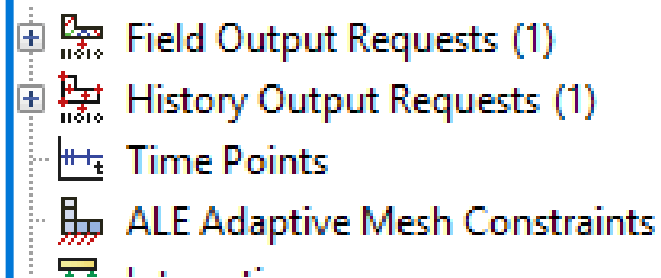

Abre-se uma janela com a lista de outputs requeridos pelos steps criados. Clique em Edit...

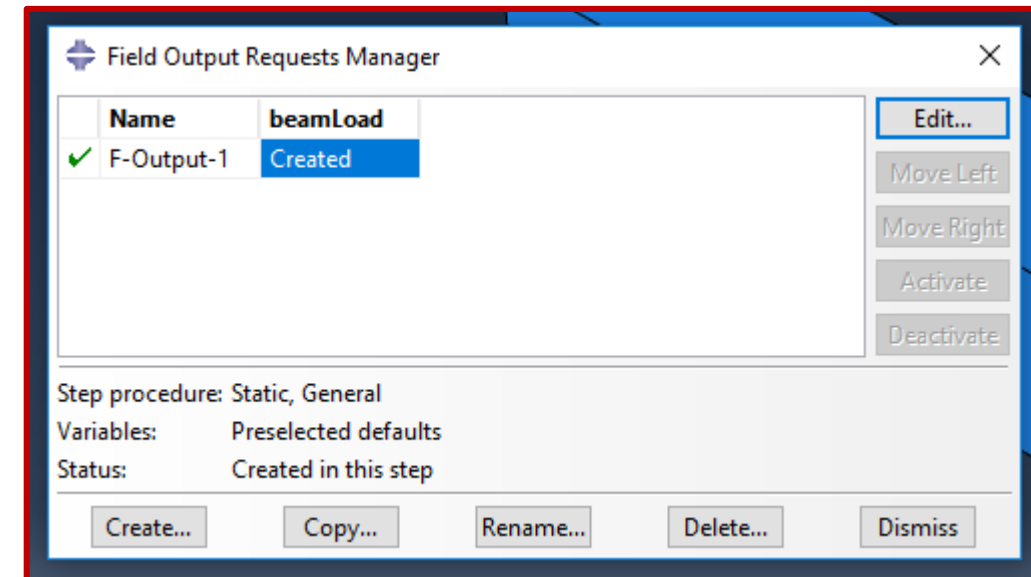



Edit Field Output Request

Name: F-Output-1
Step: beamLoad
Procedure: Static, General

Domain: Whole model Exterior only

Frequency: Every n increments n: 1

Timing: Output at exact times

Output Variables
 Select from list below Preselected defaults All Edit variables

CDISP,CF,CSTRESS,LE,PE,PEEQ,PEMAG,RF,S,U,

- Stresses
- Strains
- Displacement/Velocity/Acceleration
- Forces/Reactions
- Contact
- Energy
- Failure/Fracture
- Thermal
- Electrical/Magnetic

Note: Some error indicators are not available when Domain is Whole Model or Int

Output for rebar

Output at shell, beam, and layered section points:
 Use defaults Specify: []

Include local coordinate directions when available

OK Cancel

Frequencia de saída da resposta

Quais as variáveis de saída. Abra uma delas (Stresses, por exemplo) e veja o que será armazenado no arquivo de saída em termos de tensões. Clique Ok e, depois, Dismiss.

- Stresses
 - S, Stress components and invariants
 - MISES, Mises equivalent stress **Selecione Mises**
 - MISESMAX, Maximum Mises equivalent stress
 - TSHR, Transverse shear stress (for thick shells)
 - CTSHR, Transverse shear stress in stacked continuum shells
 - ALPHA, Kinematic hardening shift tensor
 - TRIAX, Stress triaxiality
 - VS, Stress in the elastic-viscous network
 - PS, Stress in the elastic-plastic network
 - CS11, Average contact pressure for link and three-dimensional li
 - ALPHAN, All tensor components of all the kinematic hardening
 - SSAVG, Average shell section stress
 - MISESONLY, Mises equivalent stress only
 - PRESSONLY, Equivalent pressure stress only



Vamos para o passo **Load**.
Pulamos o passo **Interaction**.
Esse passo é necessário quando temos que definir a relação entre partes. Por exemplo, o atrito, contato, interações (movimentos dependentes entre partes)...
Em nosso caso, temos somente uma parte: a viga.

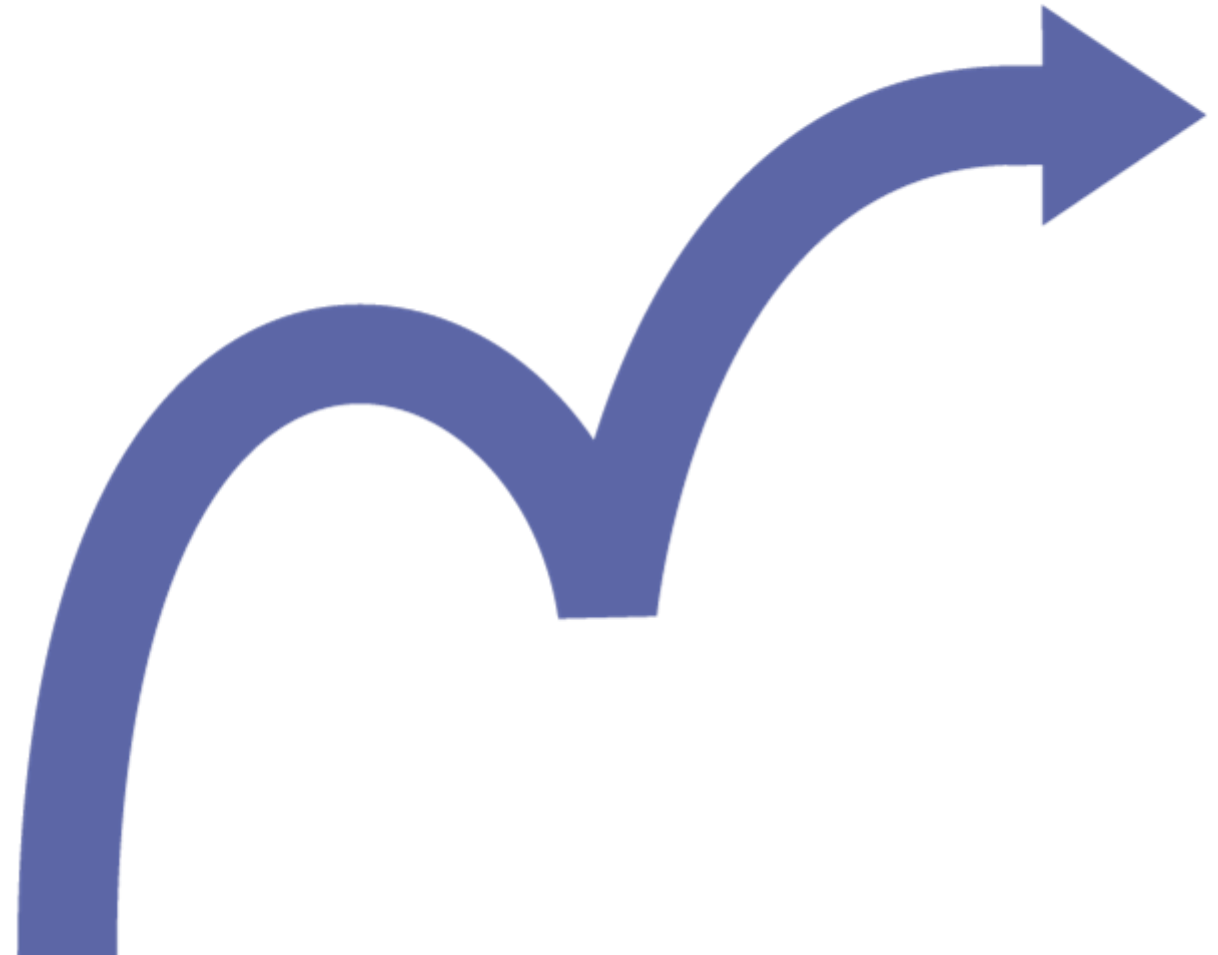

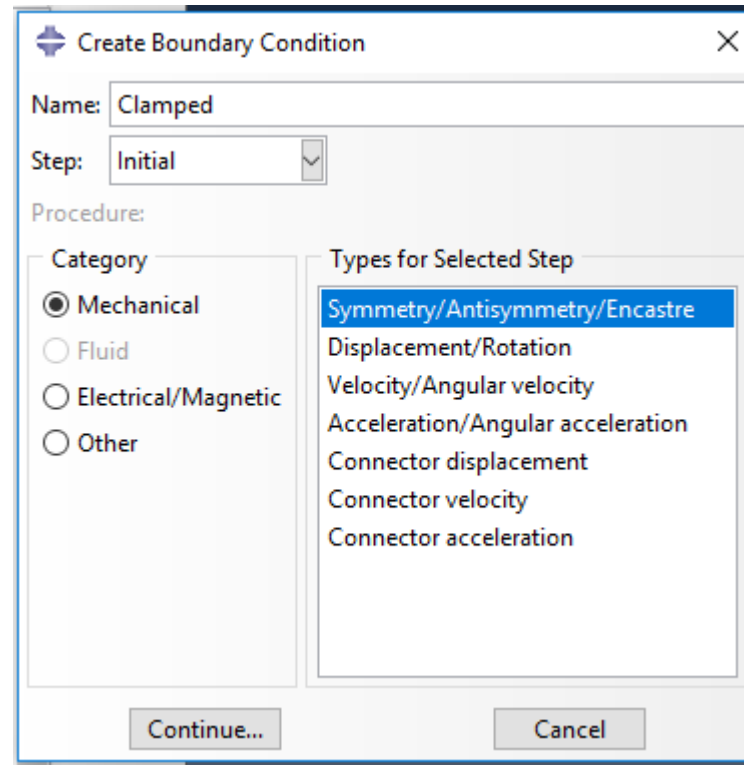
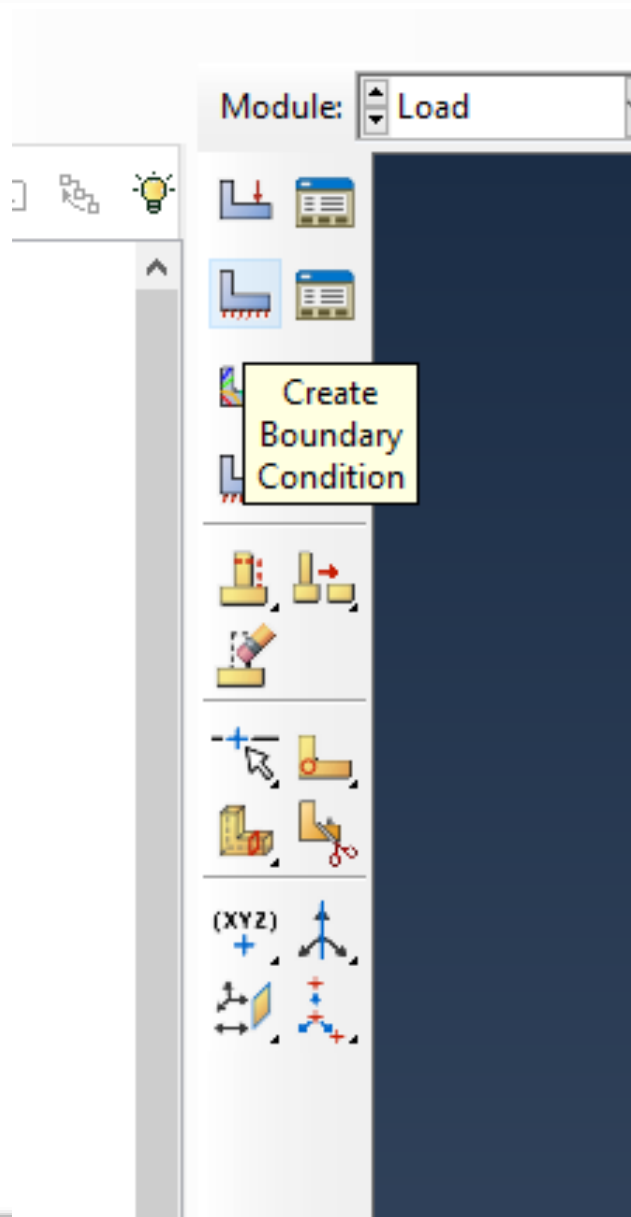

Em Load, clique em “Create Boundary Condition”

- Nomeie a condição de contorno (Clamped)
- Selecione Step “Initial”, category “Mechanical”
- Para “Types for Selected Step” selecione Symmetry/Antisymmetry/Encastre”
- Clique “Continue...”

Module: Load Model: Model-1 Step: PlateLoad

Selecione toda a lateral que será engastada.
Atenção para selecionar SOMENTE a lateral.
Clique "Done"

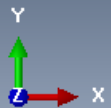
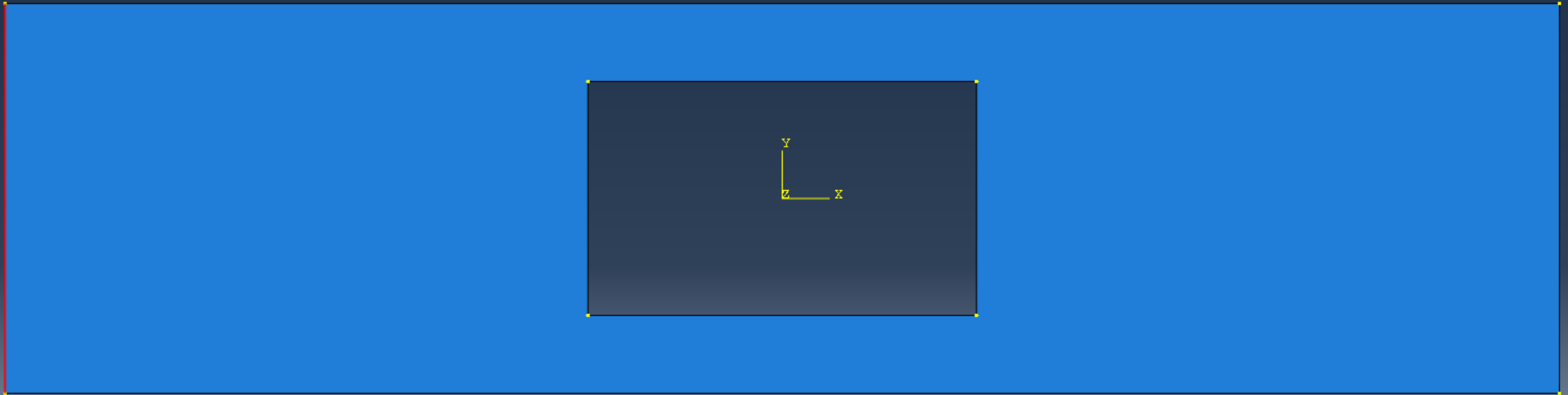

Select regions for the boundary condition (Create set: Set-1) Done

Sets... SIMULIA

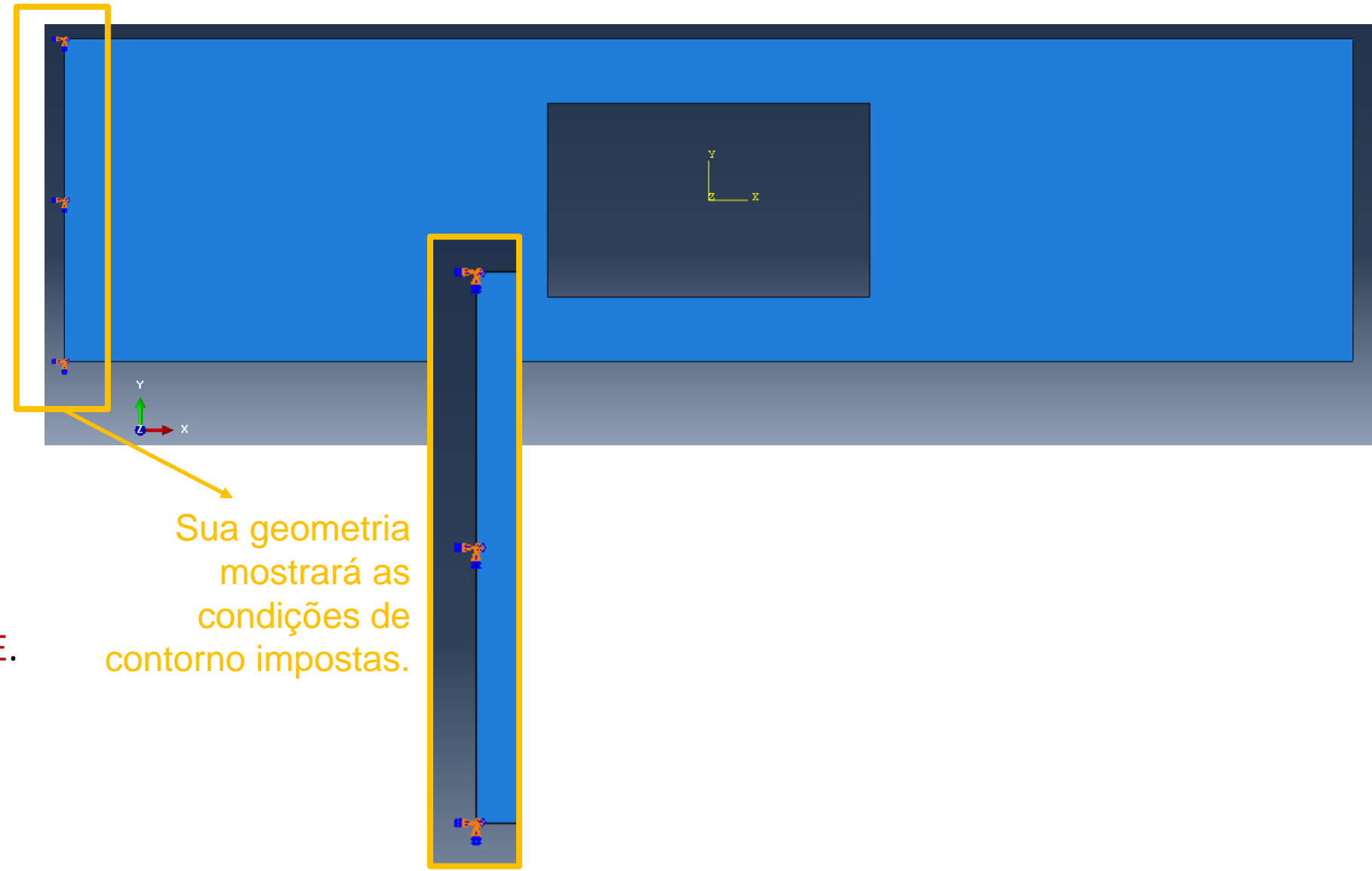
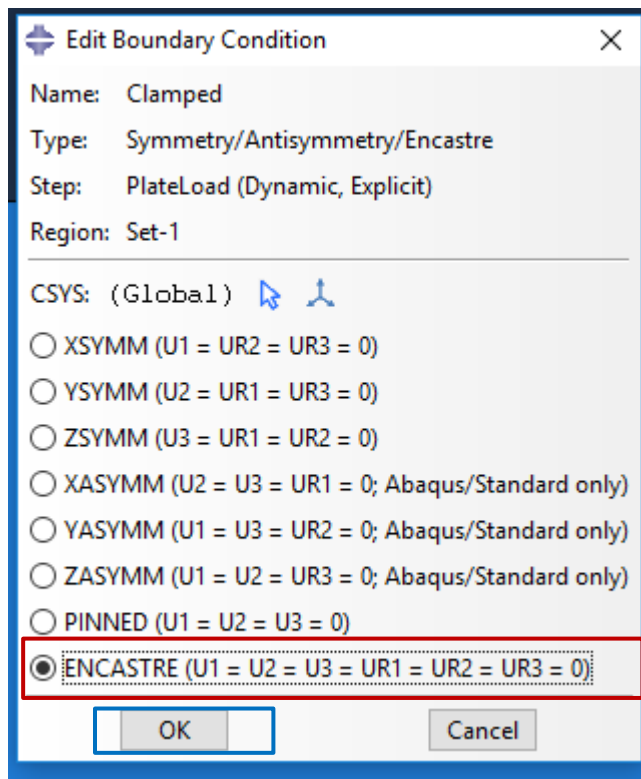

Sua geometria mostrará as condições de contorno impostas.

Selecione a opção **ENCASTRE**.

Clique "OK"



Agora que você impôs as condições de contorno, você pode aplicar a carga distribuída à face superior da viga. A carga é aplicada durante a etapa geral, estática (General, Static) que você criou usando o módulo **Step**.

Ainda em Load, clique em “Create Load”:

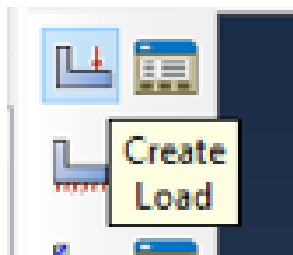

Dê um nome ao carregamento (Pressure).

Quando você selecionar o Step que você criou (PlateLoadLoad), surgirá

Category (selecione *Mechanical*)
Types for Selected Step (selecione *Pressure*)

Clique “Continue”

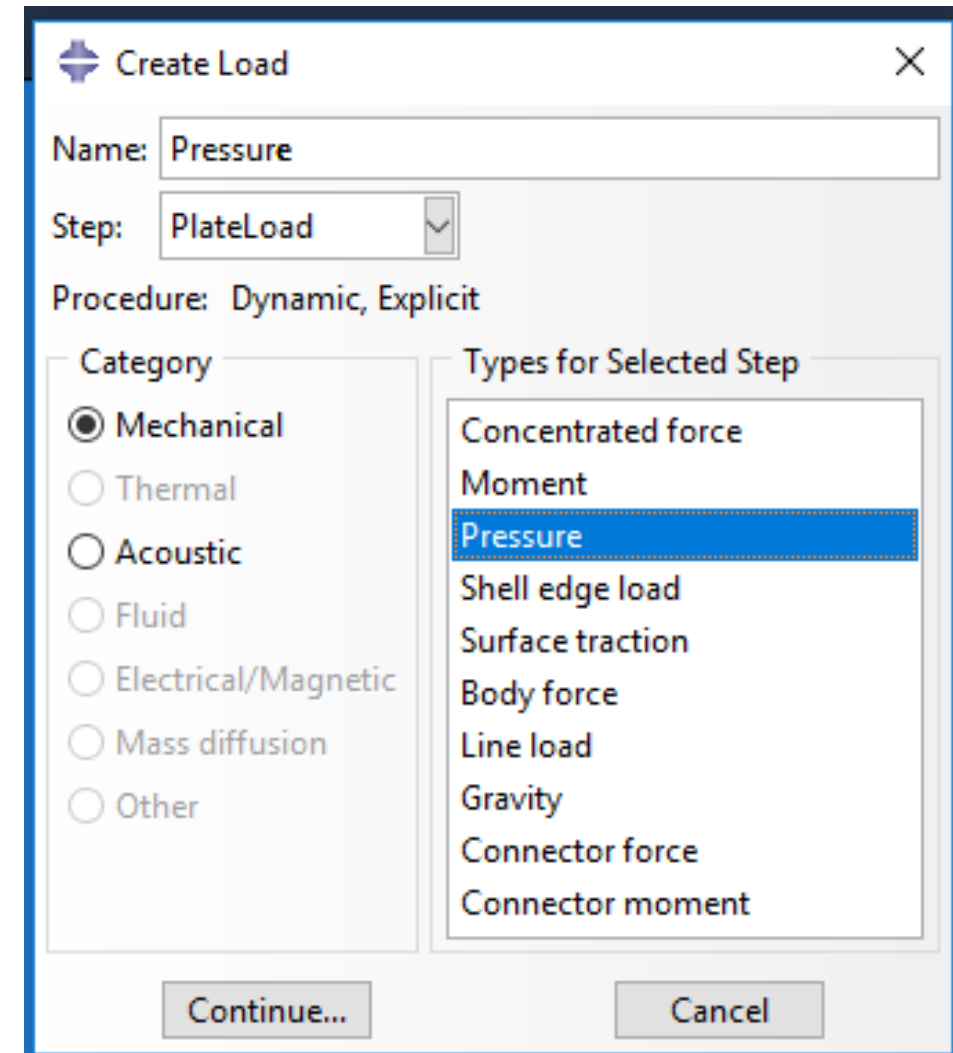

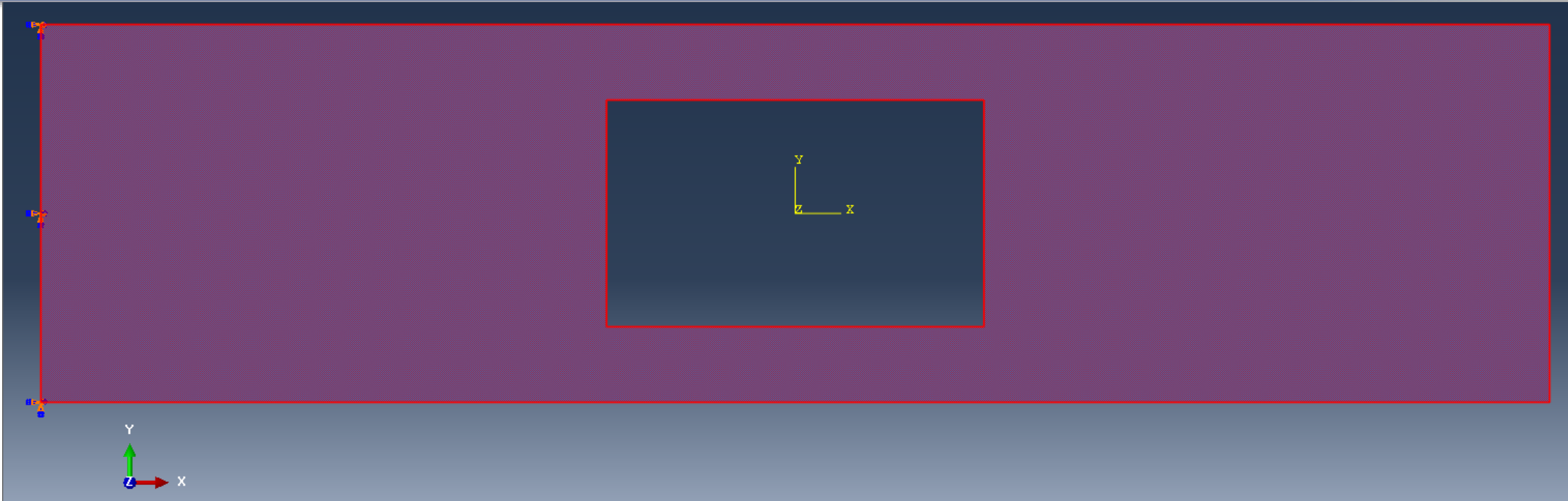

Selecione toda a face que será aplicada a pressão.

Clique em Done.

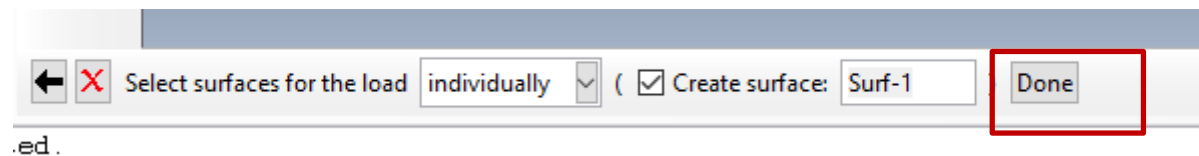

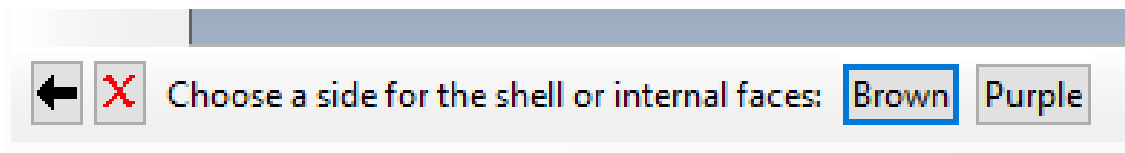
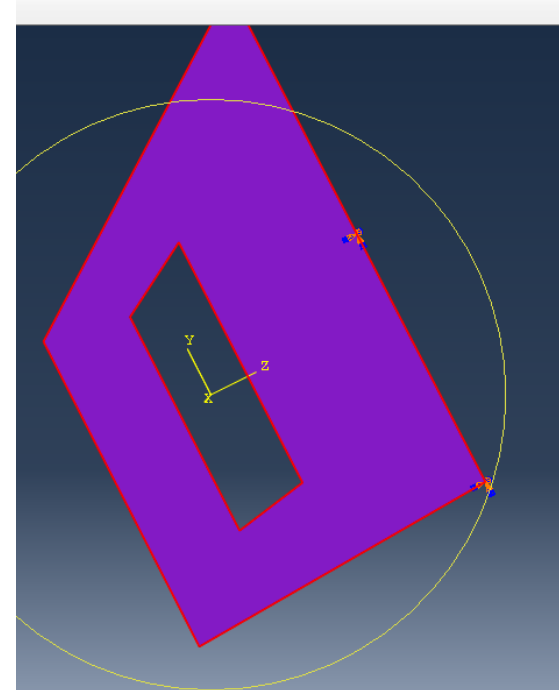
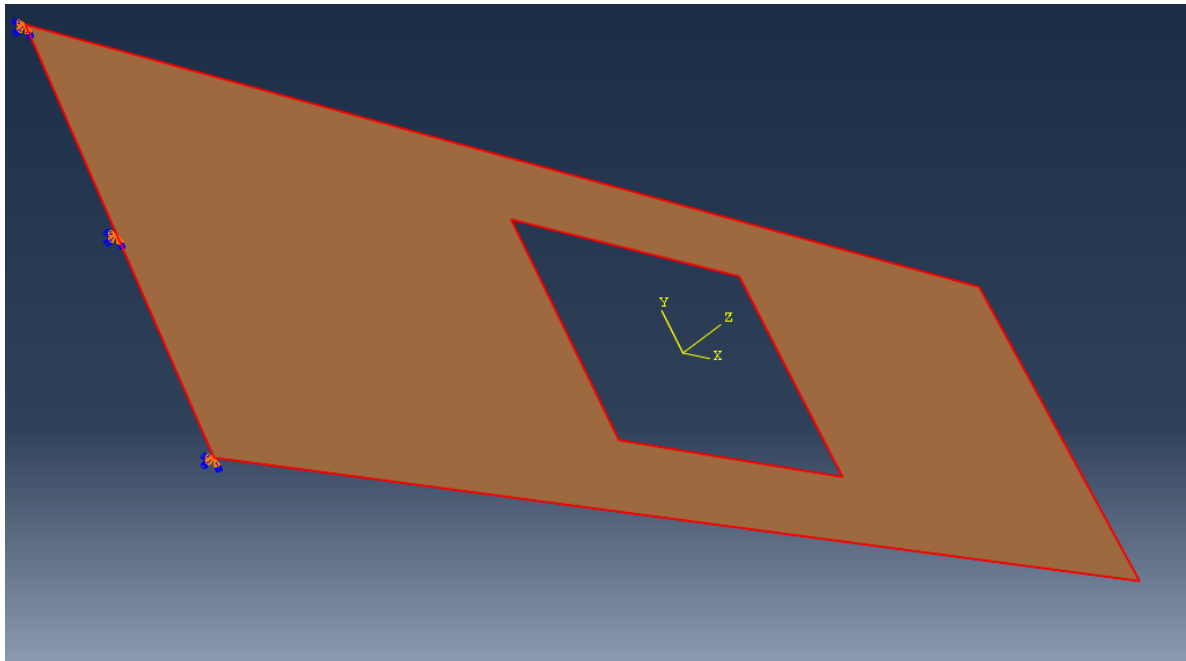

ed

Você deverá selecionar entre a face “Brown” ou “Purple”. Confira se a face *Brown* é a superior e selecione.



Digite uma **Magnitude** de 0.02 para a carga.

Clique na figura da onda para criar um carregamento variável no tempo...

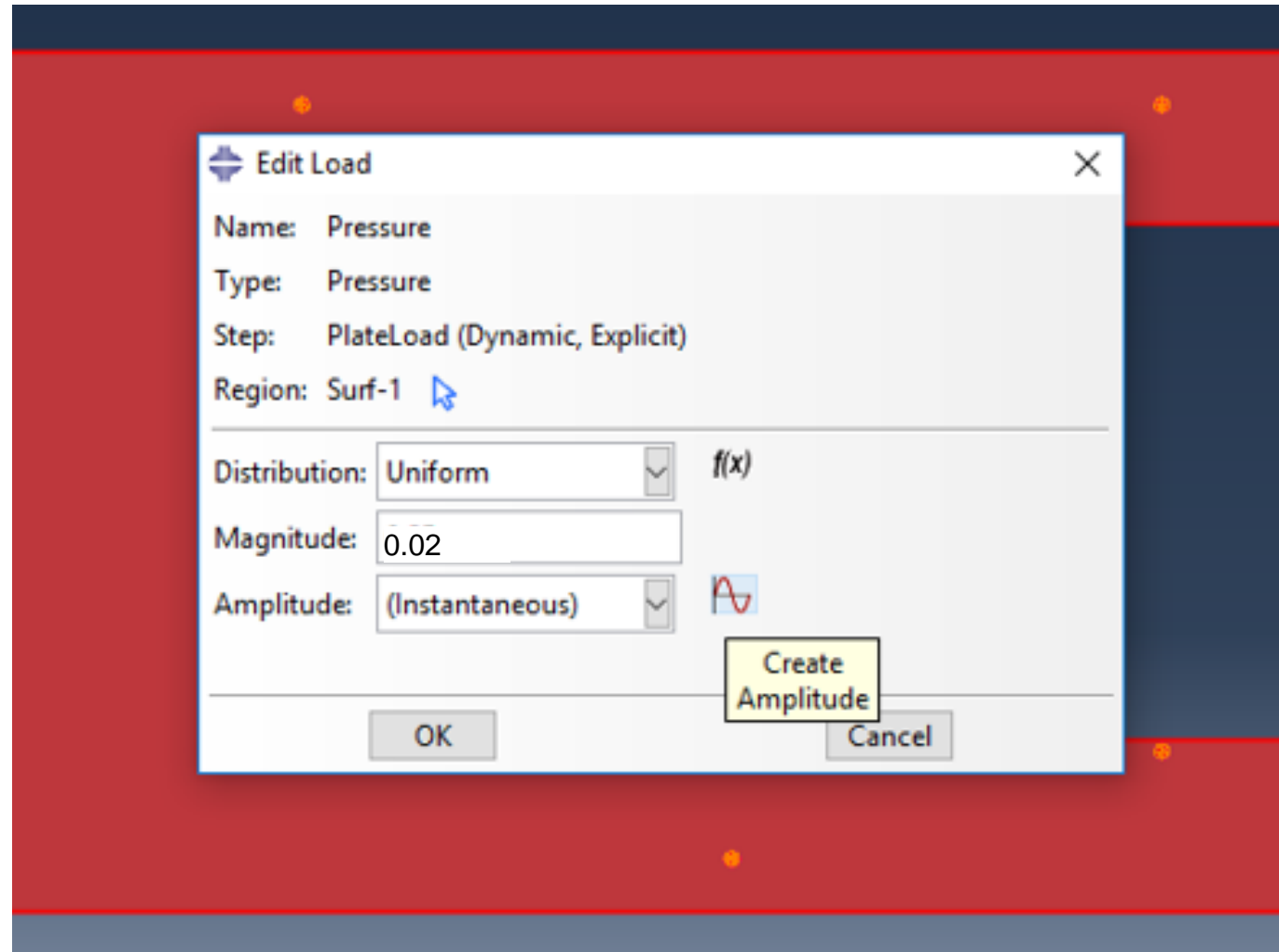

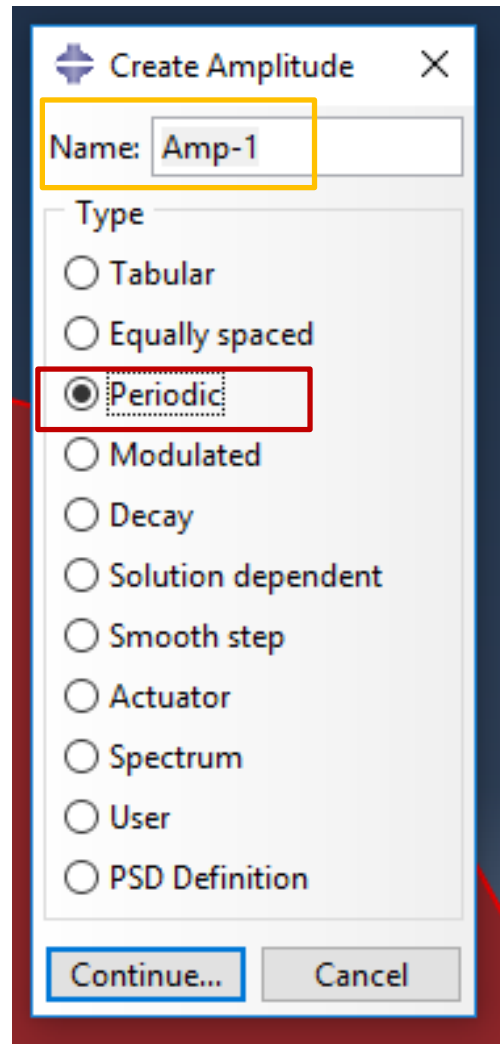

Você sempre pode dar um nome para o carregamento

Clique em periódico

Continue...

Abrirá a seguinte janela

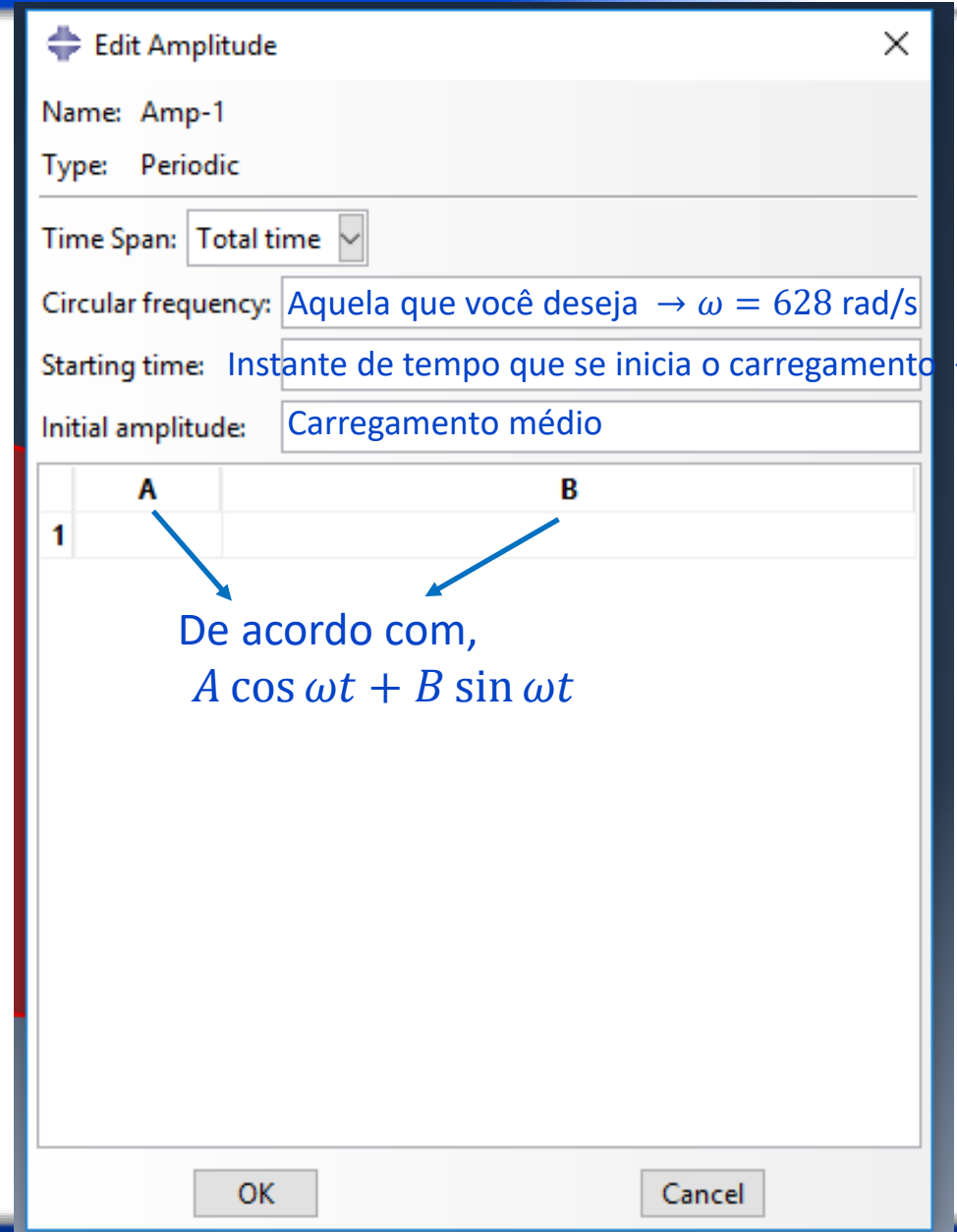

De acordo com,
 $A \cos \omega t + B \sin \omega t$

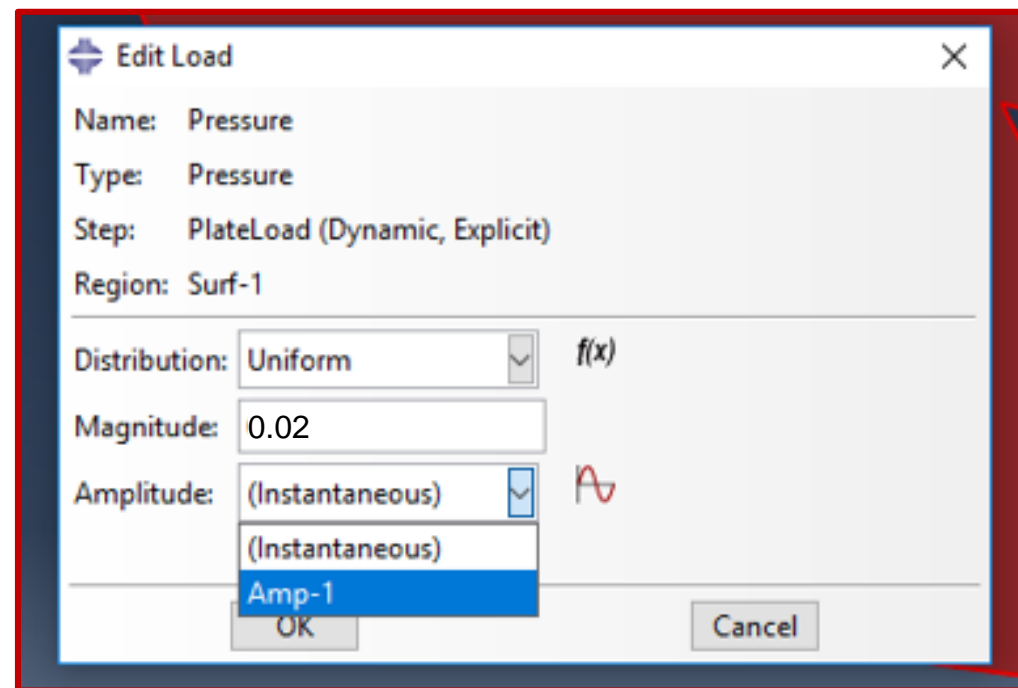
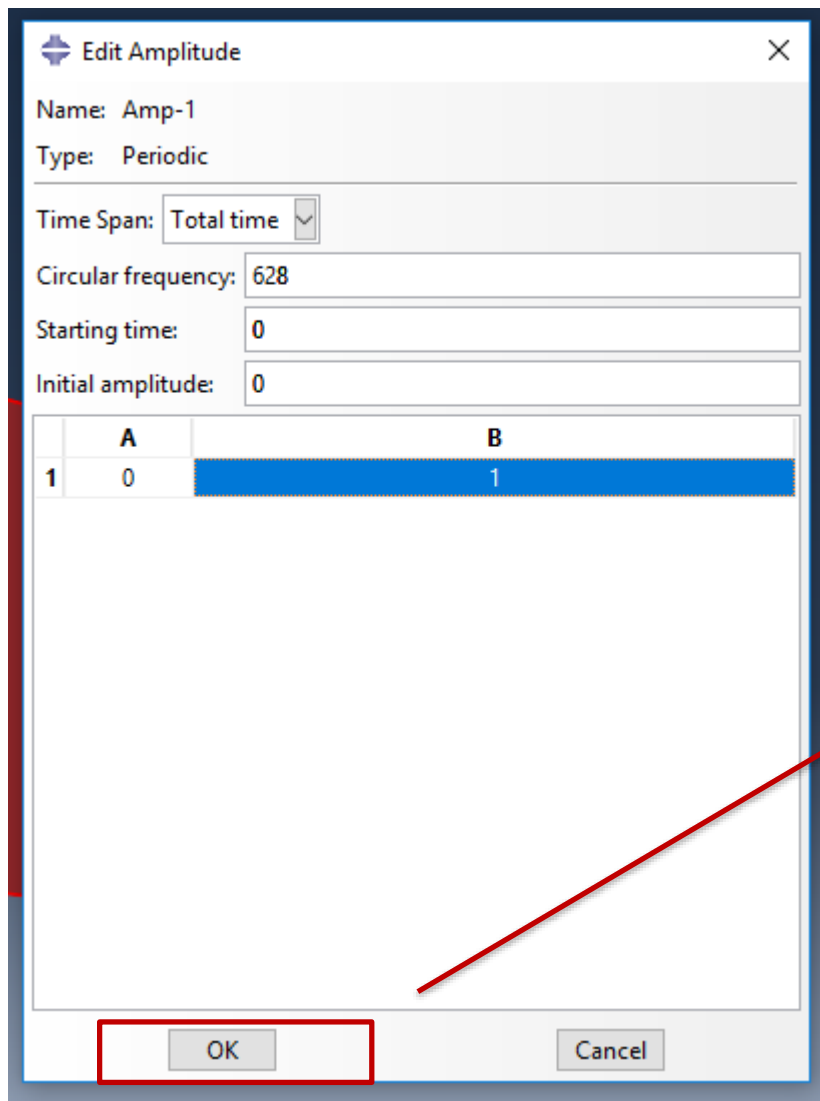

Selecione a amplitude que você acabou de gerar.
Clique Ok.



Sua viga está carregada. Se quiser, verifique em “Load Manager”:

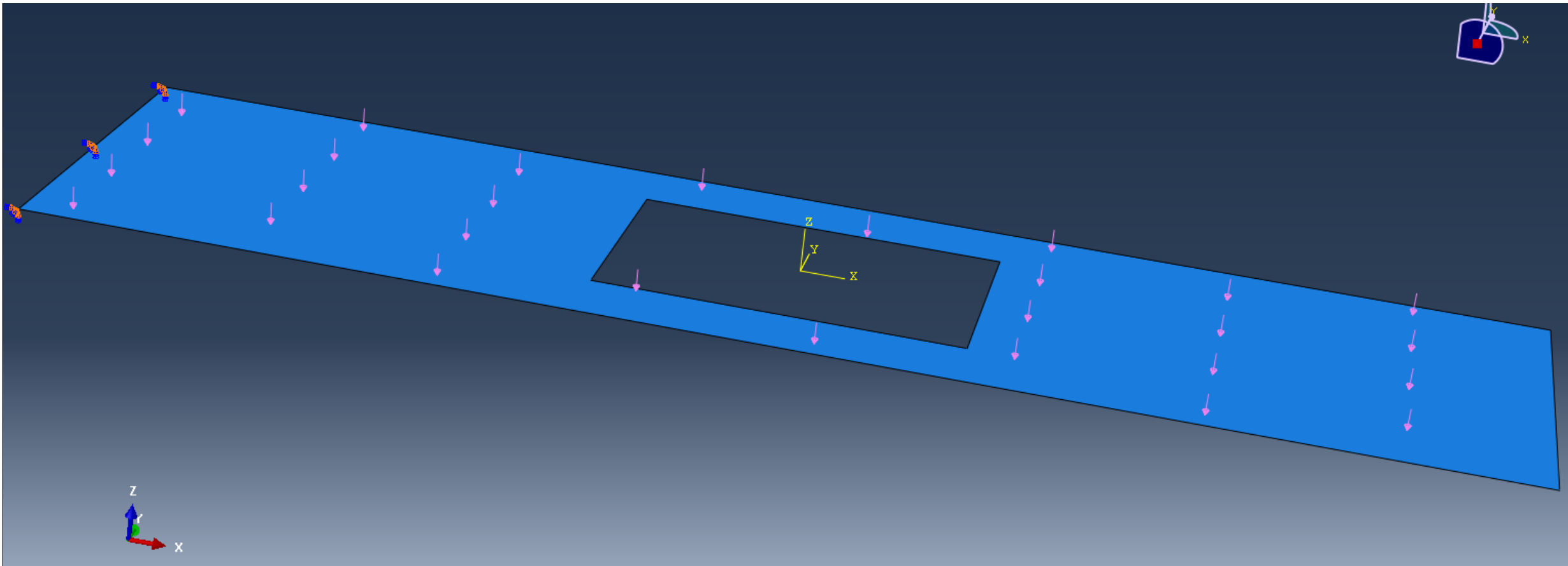
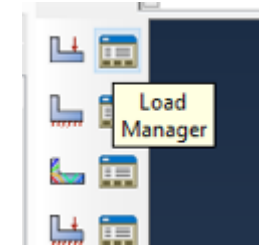



Na lista Module, localizada na barra de ferramentas, clique em Mesh para entrar no módulo de malhamento do problema.

Importante:

Embora você possa criar uma malha em qualquer ponto após a criação da **Assembly**, você geralmente faz isso depois de configurar o resto do modelo, já que itens como cargas, condições de contorno e etapas *dependem da geometria subjacente e não da malha*. Se você faz com que dependam da malha (por exemplo, impõe condições de contorno (cc) nos nós e não na face), cada vez que mudar a malha deverá refazer as cc.



Clique em “Assign Mesh Controls”

A caixa de diálogo Mesh Controls é exibida. ABAQUS colore as regiões do seu modelo para indicar qual técnica ele usará para fazer a malha nessa região. Como usará malhas livres, exibirá a geometria em rosa.

Aceite default
Clique OK.

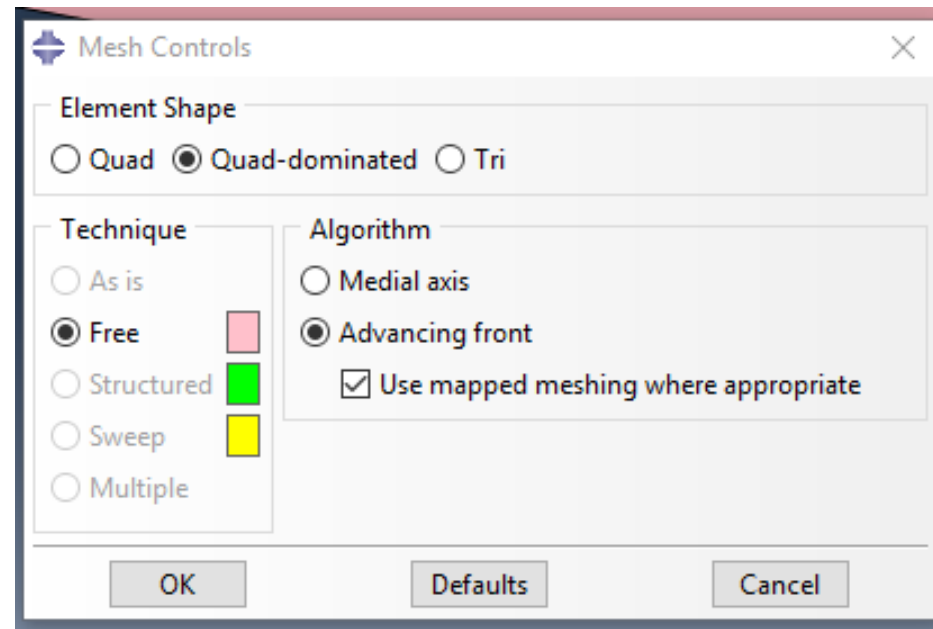

Para escolher o tipo de elemento,

- clique em “Assign Element Type”;
- selecione a sua placa;
- “Done”

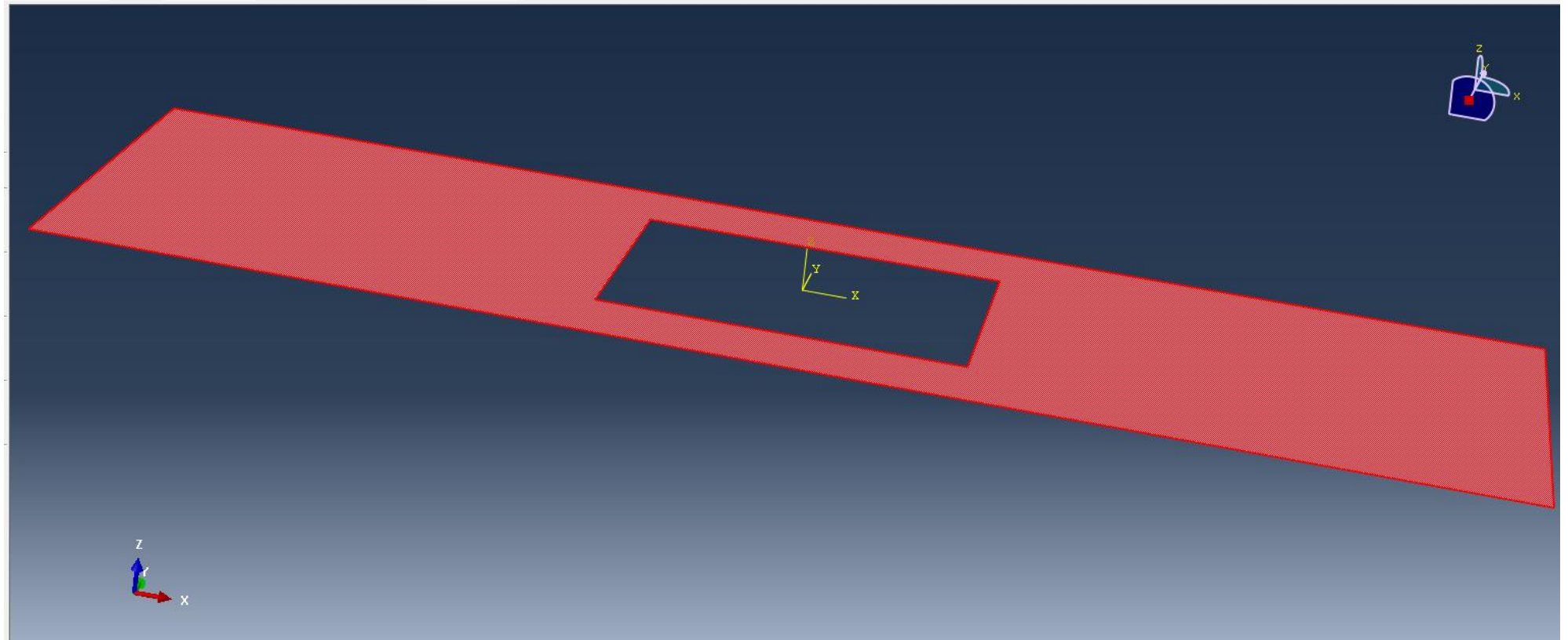
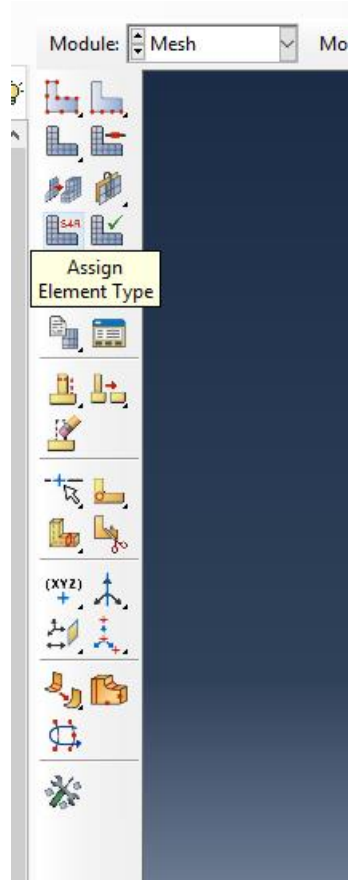



Na caixa de diálogo que se abriu, aceite as seguintes seleções default que controlam os elementos disponíveis:

- Em **Element Library** o default é **Standard**.
- **Linear** é a **Geometric Order** default .
- **Quad** é a **Family** default dos elementos.

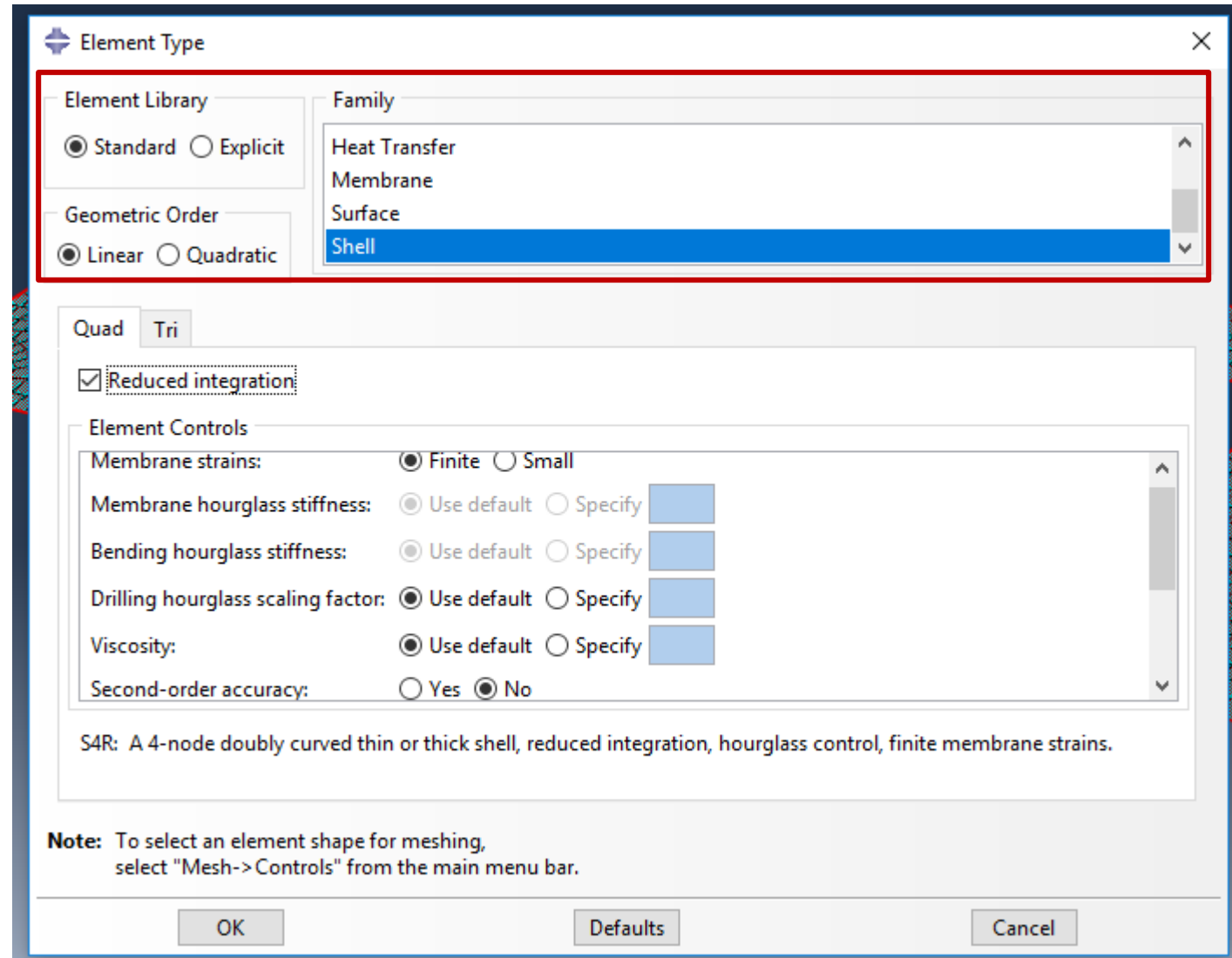



Na parte inferior da caixa de diálogo, examine as opções de forma do elemento. Uma breve descrição da seleção de elemento padrão está disponível na parte inferior de cada aba.

Uma vez que o modelo shell, são mostrados apenas os tipos de elementos planos de quatro nós **Quad**, e três nós **Tri**.

Clique na guia **Quad** tire a opção de “Reduced Integration”.

Uma descrição do tipo de elemento S4 aparece na parte inferior da caixa de diálogo. O software agora irá associar elementos S4 com os elementos na malha.

Clique OK

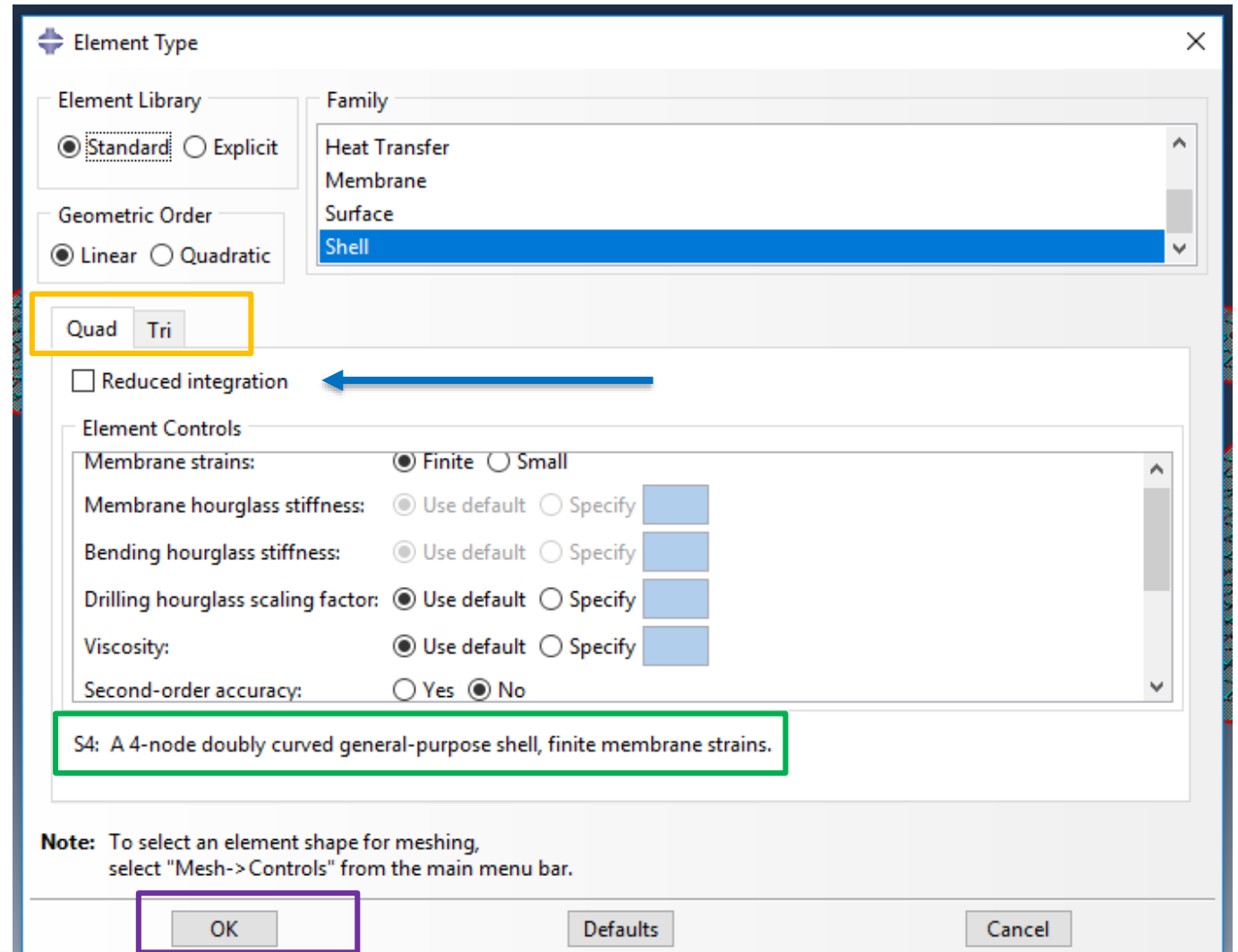

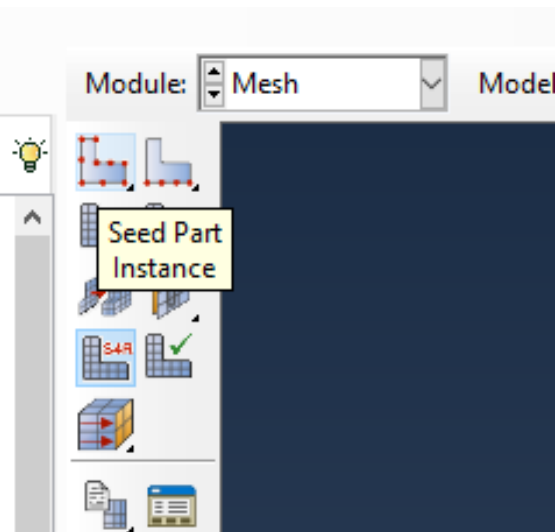

Clique em “Seed Part Instance” para definir a dimensão da malha

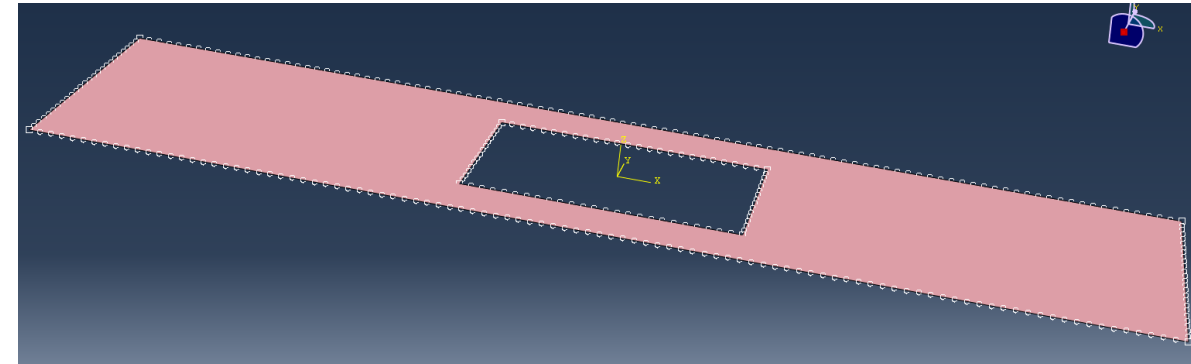

Essa será a visão da placa no Viewport

Escolha uma dimensão aproximada para seu elemento. Em geral, menor elemento, maior precisão, maior custo computacional (se seu Abaqus tem limite de nós, verifique se esse valor não foi ultrapassado).

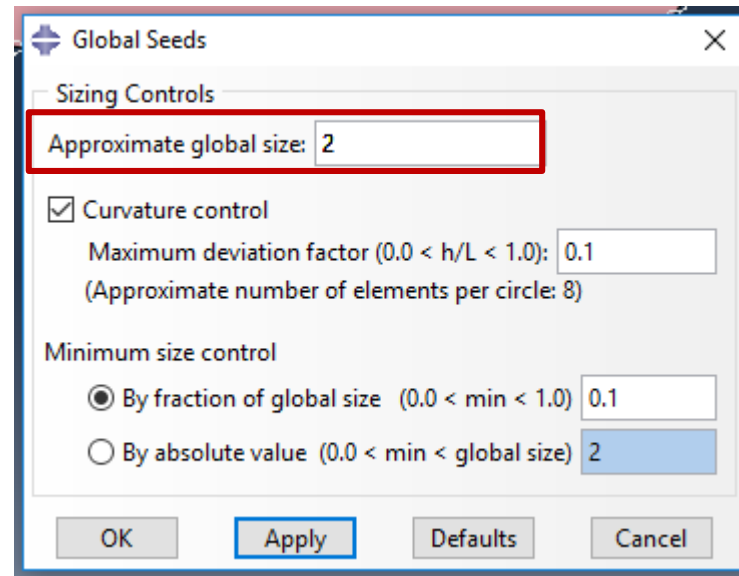



Clique em “Mesh Part Instance” para gerar a malha.

Clique em “Yes”.

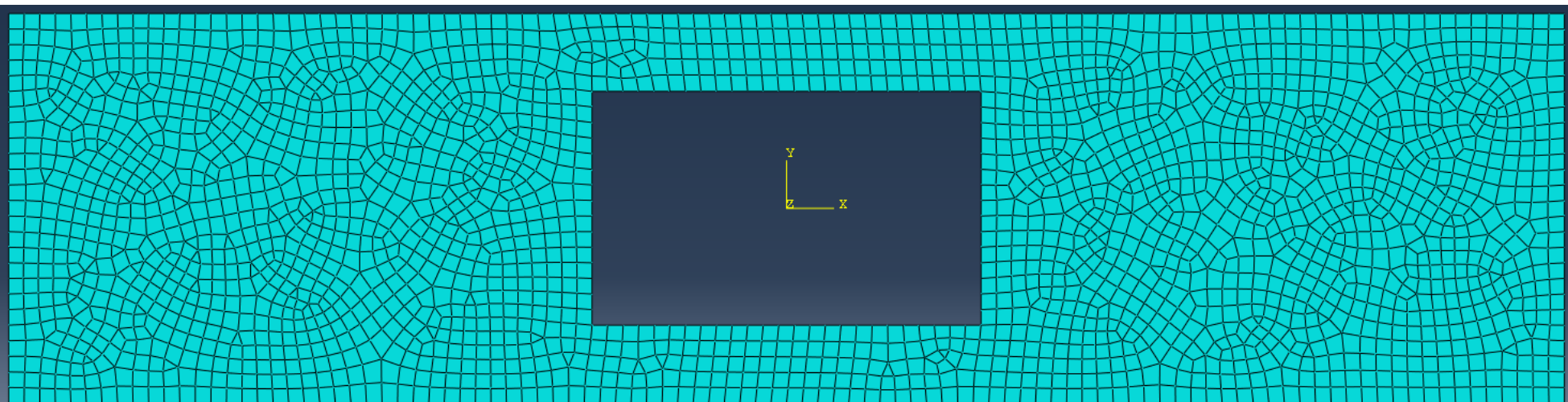
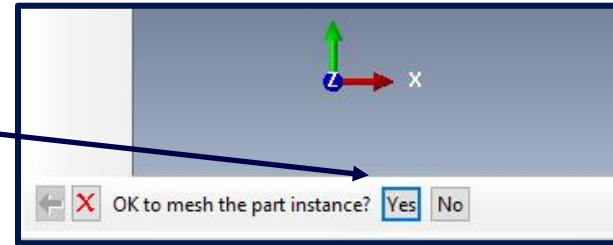

Sua malha está pronta.

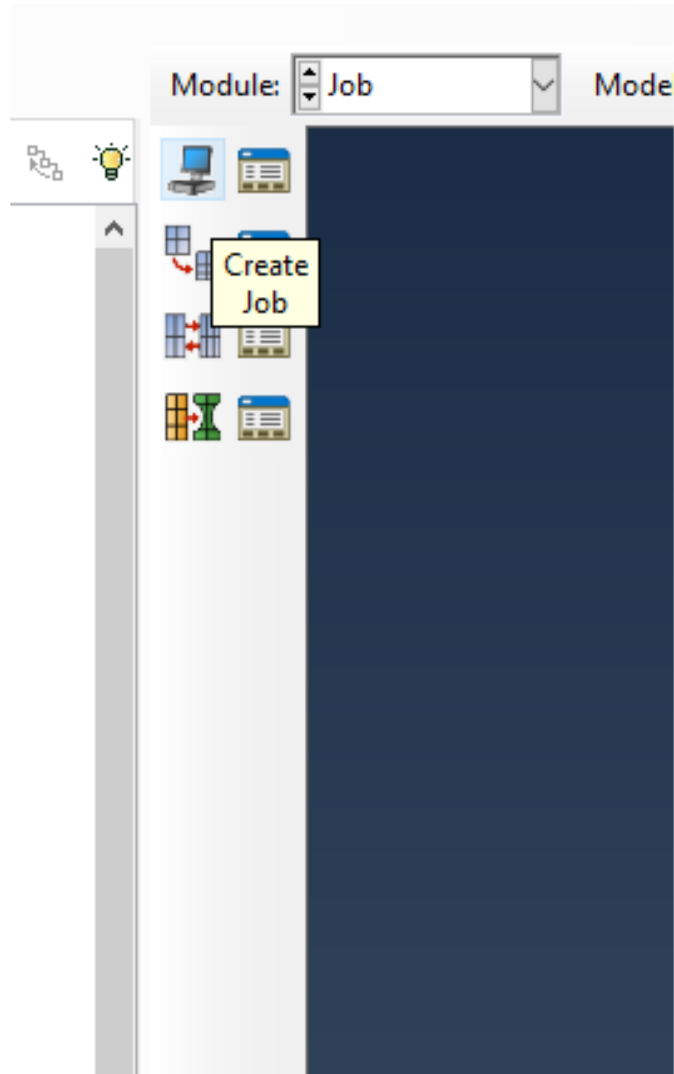

Clique em “Create Job”
Dê um nome para seu Job (Deform)
Clique em “Continue...”

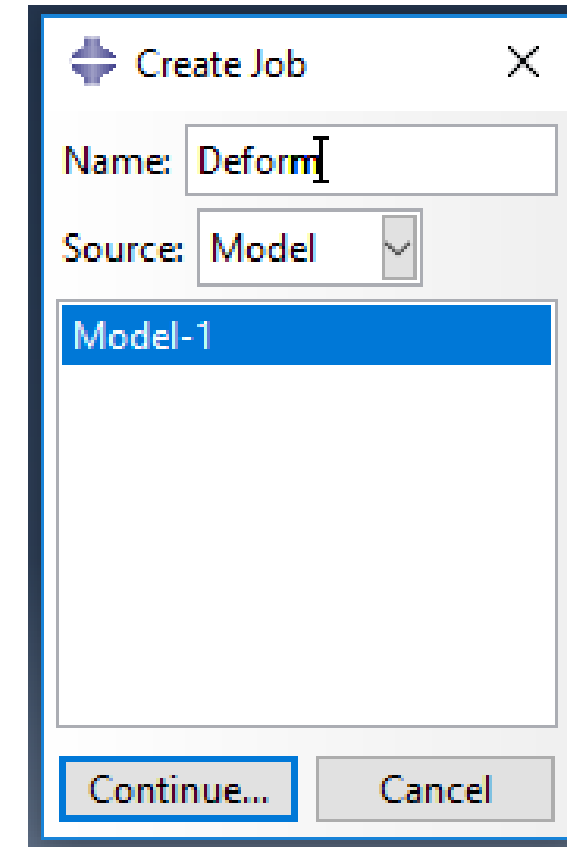

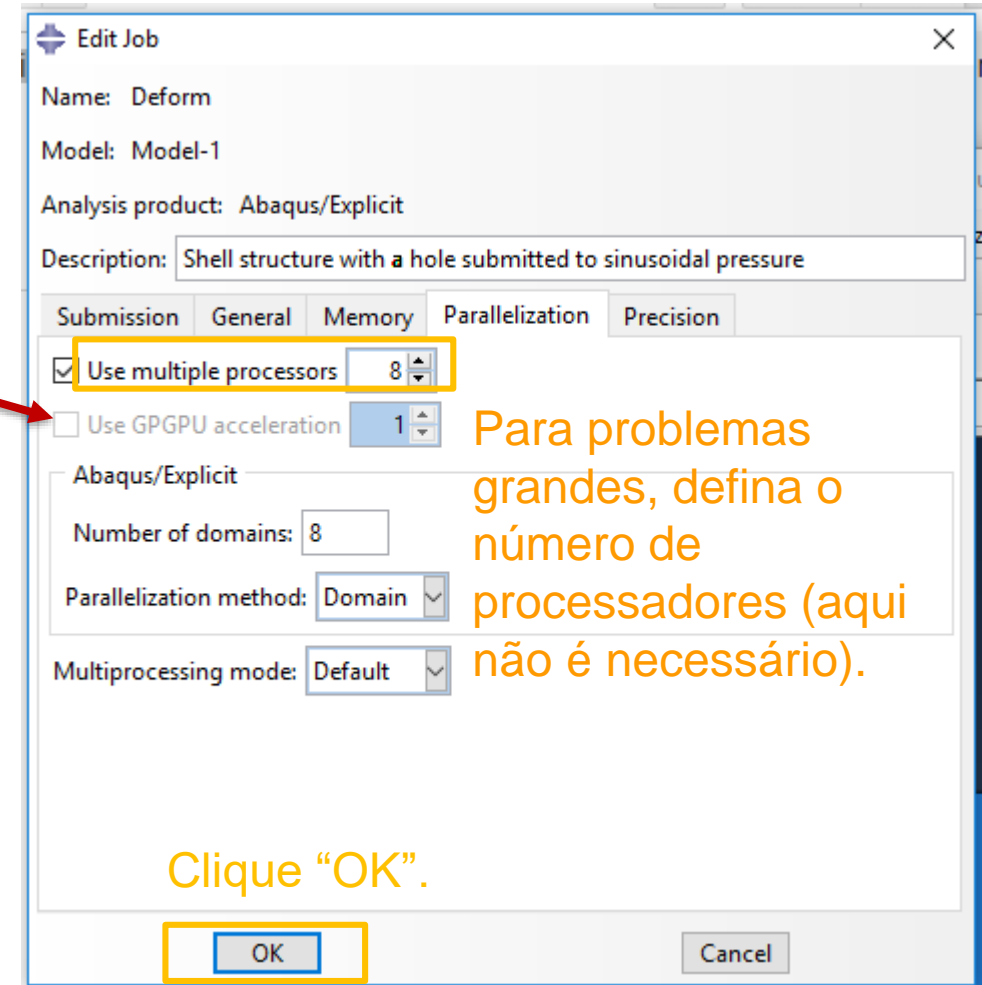
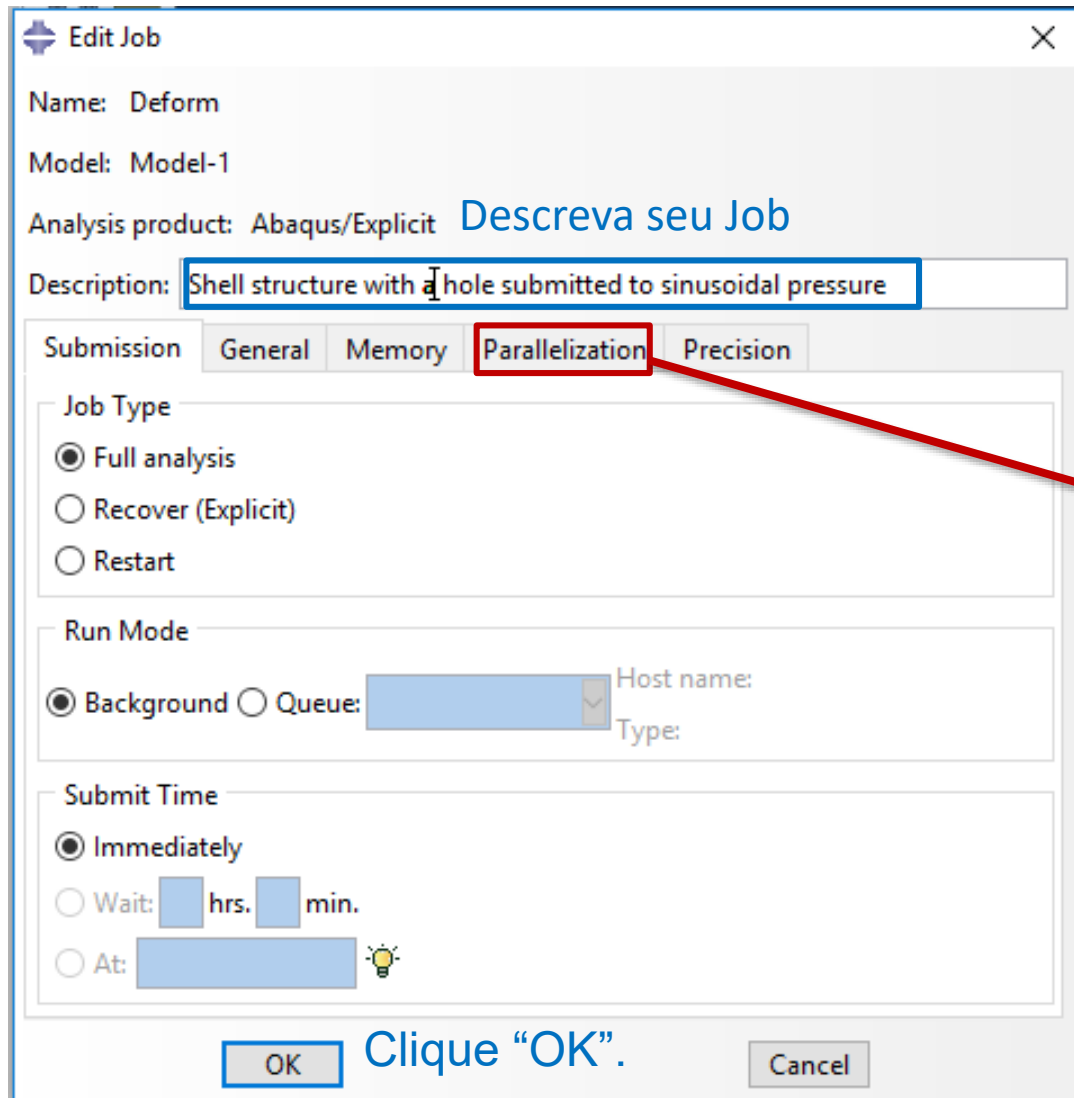

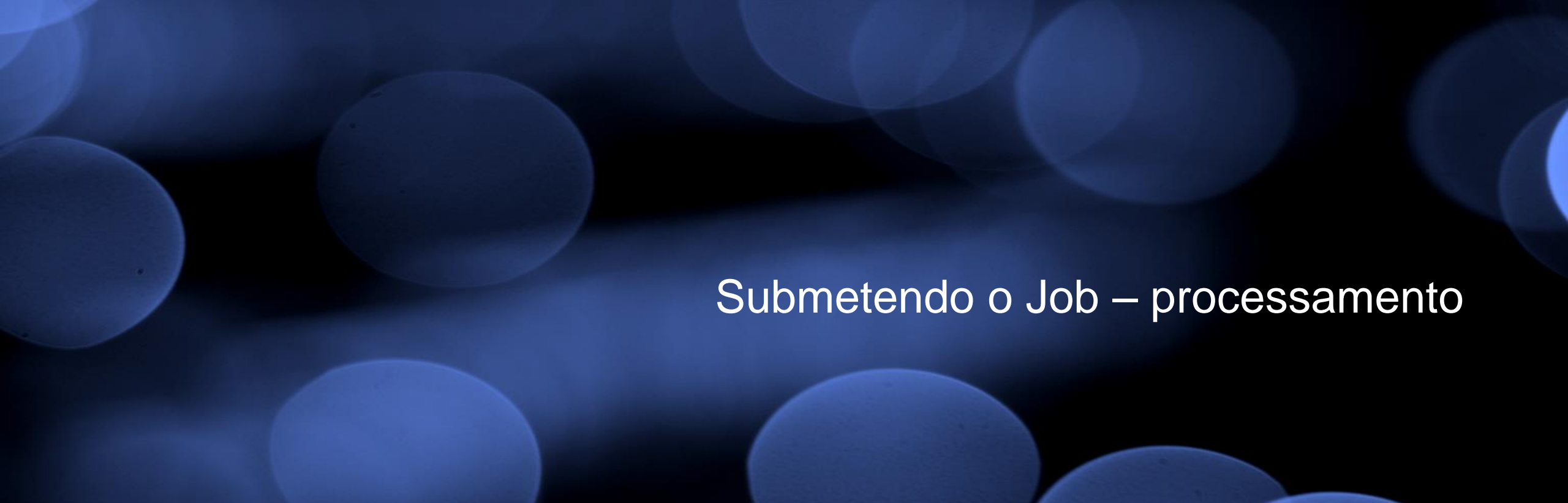

Submetendo o Job – processamento

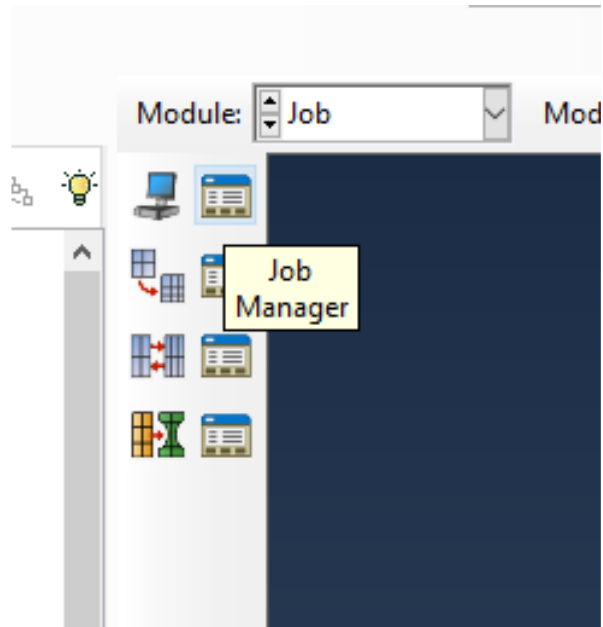

Em “Job Manager”, submeta seu trabalho,

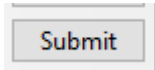



Primeiro, o programa irá analisar se seu modelo está ok (status Submitted)

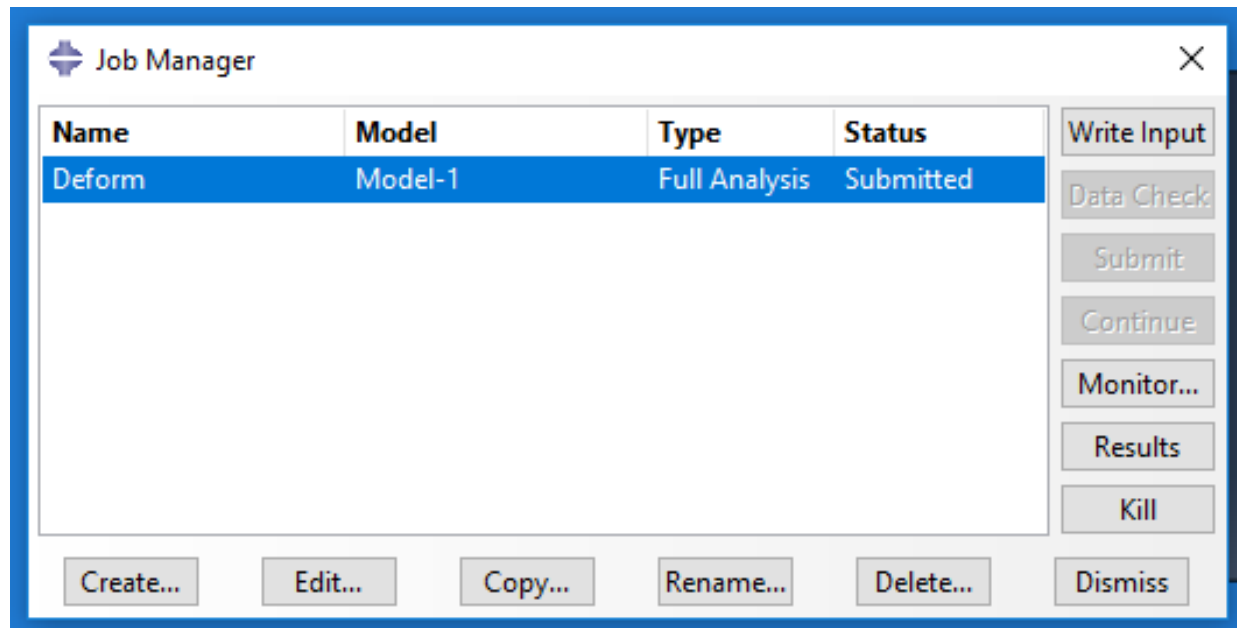

```
The job "Deform" has been created.  
The job input file "Deform.inp" has been submitted for analysis.
```



Depois, a análise se inicia (status Running).

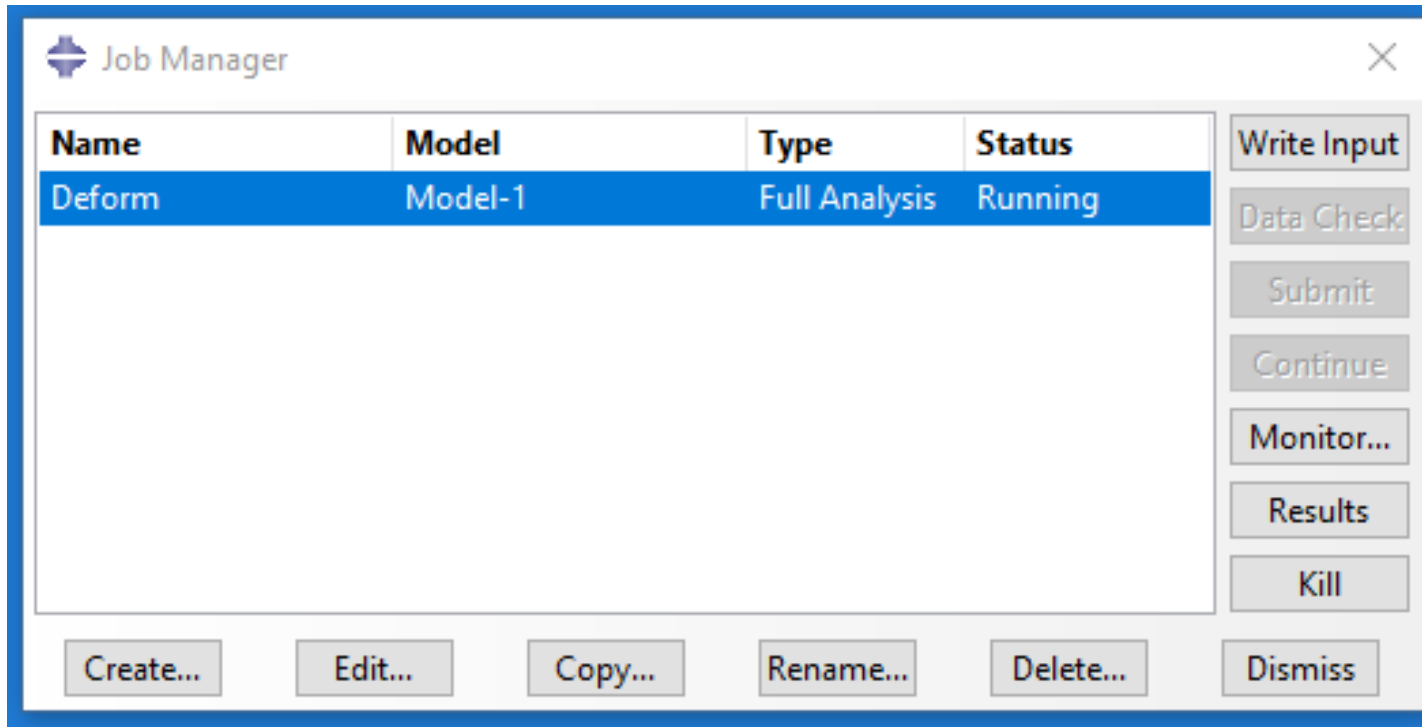

```
The job "Deform" has been created.  
The job input file "Deform.inp" has been submitted for analysis.  
Job Deform: Analysis Input File Processor completed successfully.  
Job Deform: Abaqus/Explicit Packager completed successfully.
```

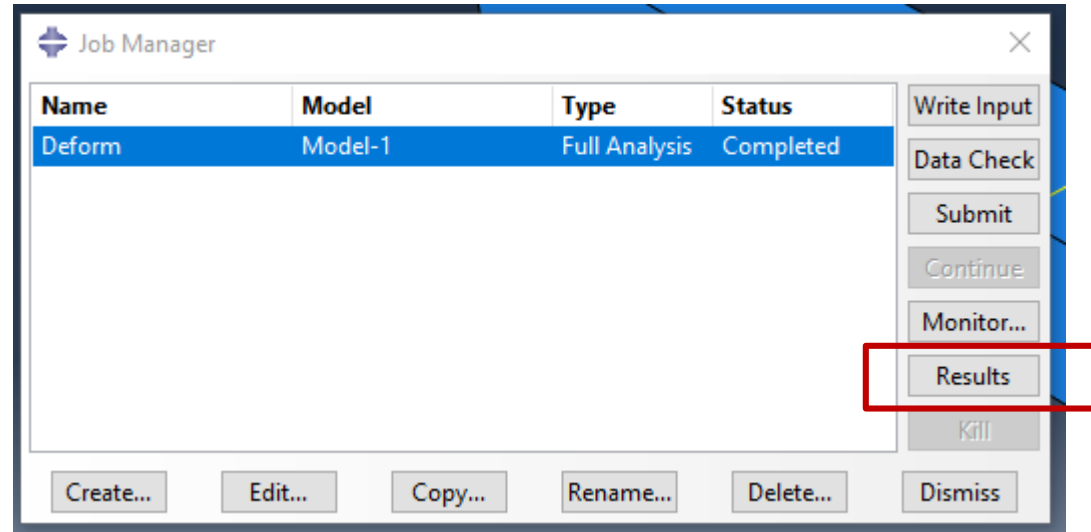



Quando a análise tiver terminado (status "Completed"), clique em "Results"

```
The job input file "Deform.inp" has been submitted for analysis.  
Job Deform: Analysis Input File Processor completed successfully.  
Job Deform: Abaqus/Explicit Packager completed successfully.  
Job Deform: Abaqus/Explicit completed successfully.  
Job Deform completed successfully.
```

The background of the slide features a dark blue gradient with several out-of-focus, glowing blue circles of varying sizes, creating a bokeh effect.

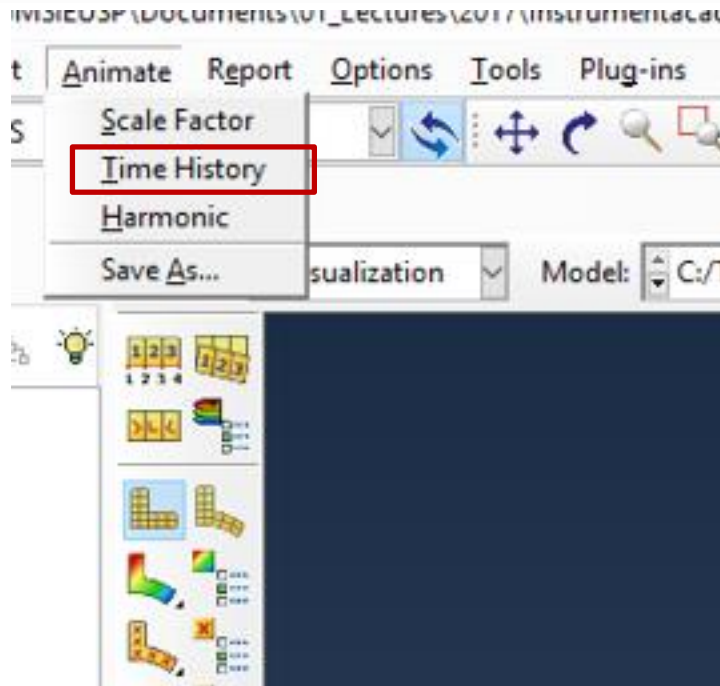
Resultados – Pós processamento



Veja a animação em
Animate
Time History.

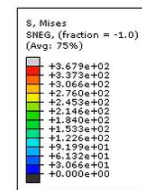

Step: PlateLoa Frames: 0
Total Time: 0.000000

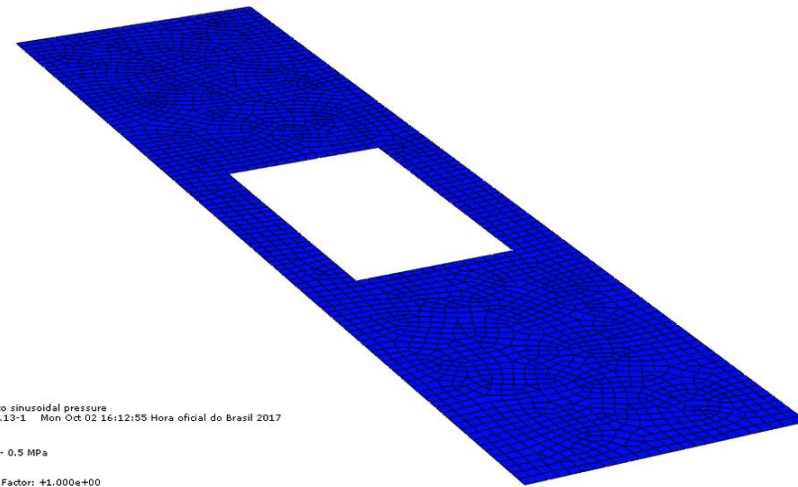

Shell structure with a hole submitted to sinusoidal pressure
ODB: Deform.odb Abaqus/Explicit 6.13-1 Mon Oct 02 16:12:55 Hora oficial do Brasil 2017

Step: PlateLoad, Sinusoidal pressure - 0.5 MPa
Increment: 0; Step Time = 0.0
Primary Var: S, Mises
Deformed Var: U Deformation Scale Factor: +1.000e+00

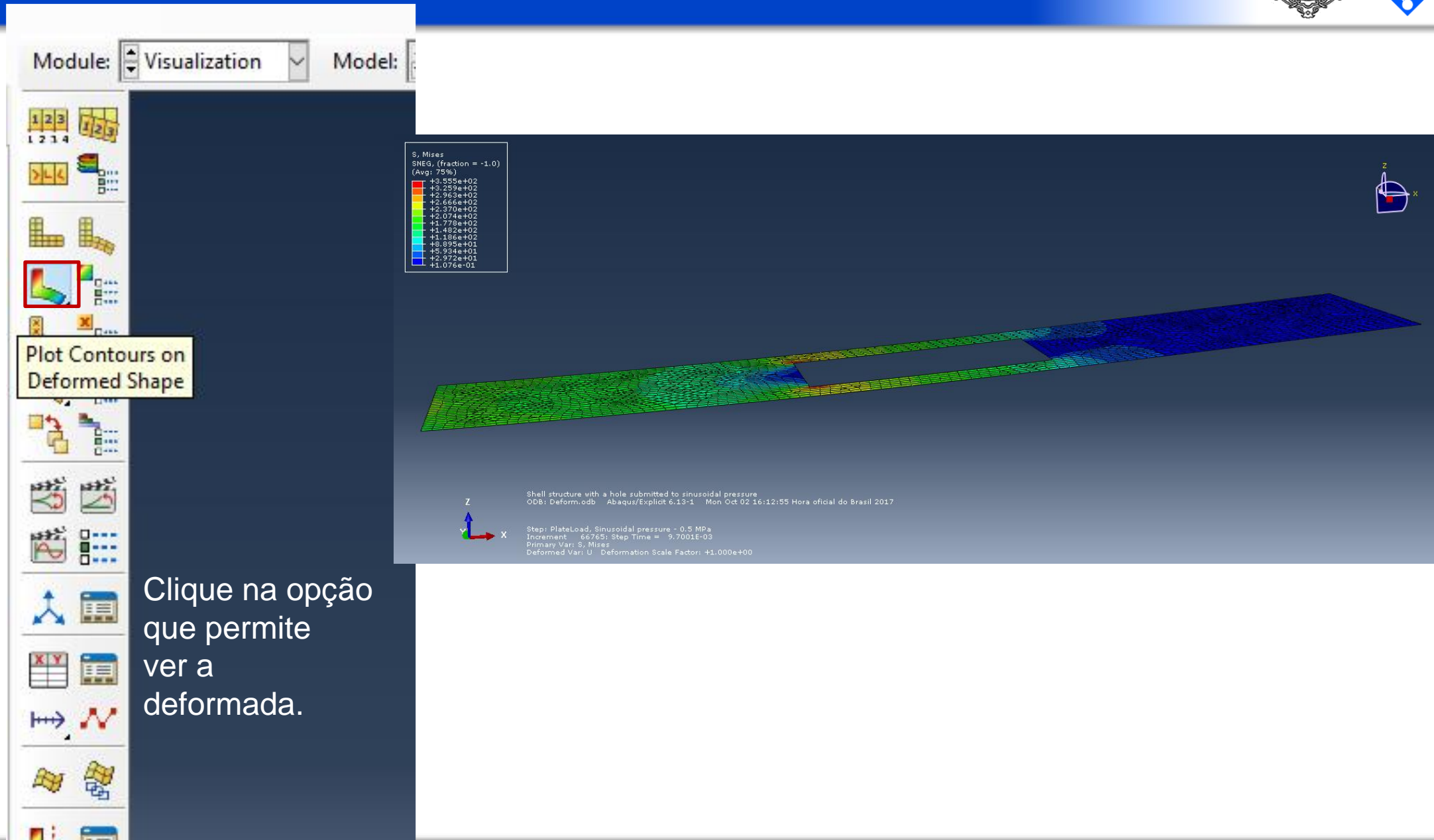

Clique na opção que permite ver a deformada.

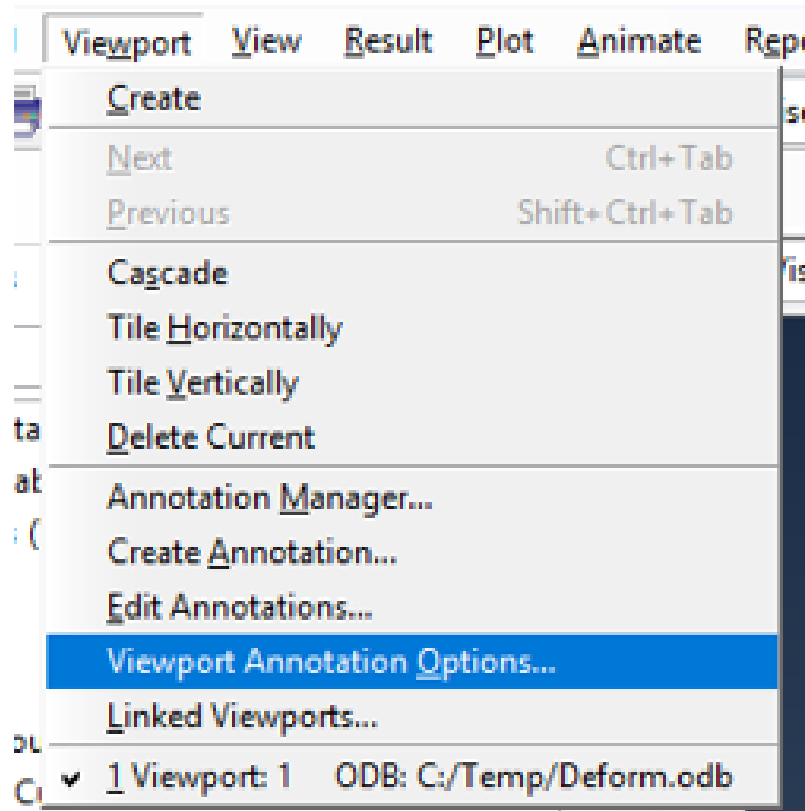

Em Viewport → Viewport Annotation Options...

Defina o que você quer ver na tela ou não...

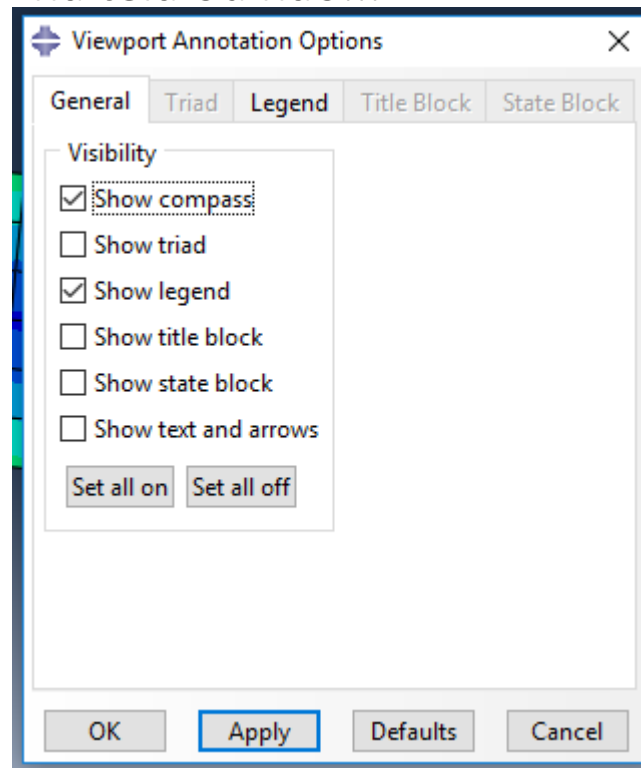

Ou os dados da legenda...

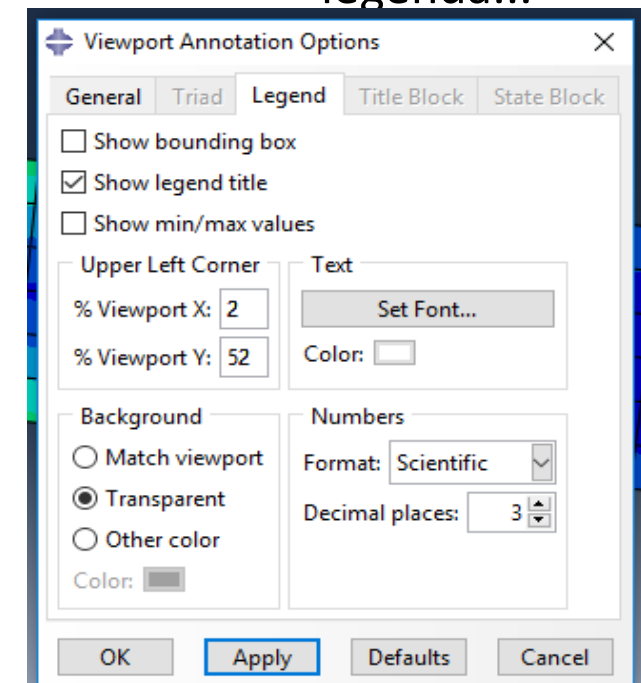

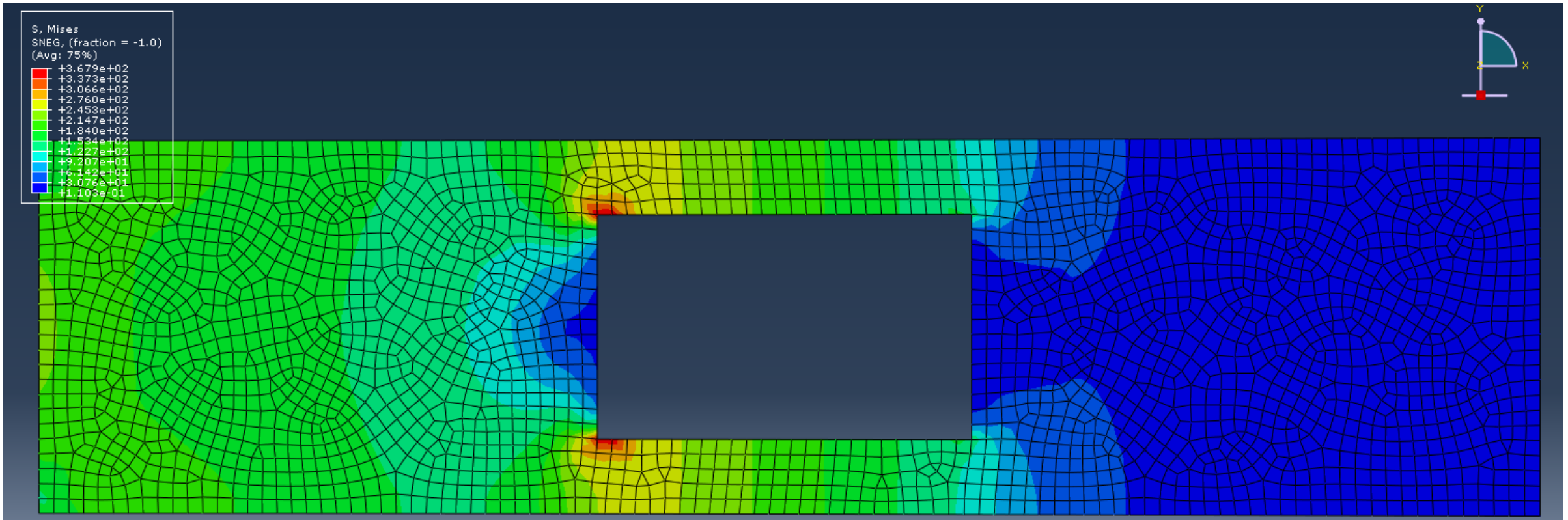

Essa visualização é da tensão de von Mises. Você pode visualizar outras variáveis mudando a seleção em:

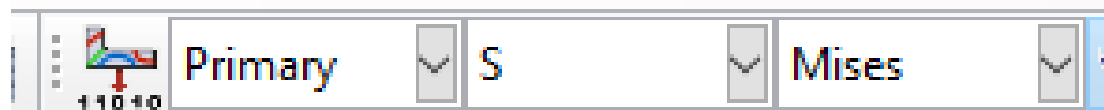

Para mudar o fator de escala da deformada, vá em Options... Common...

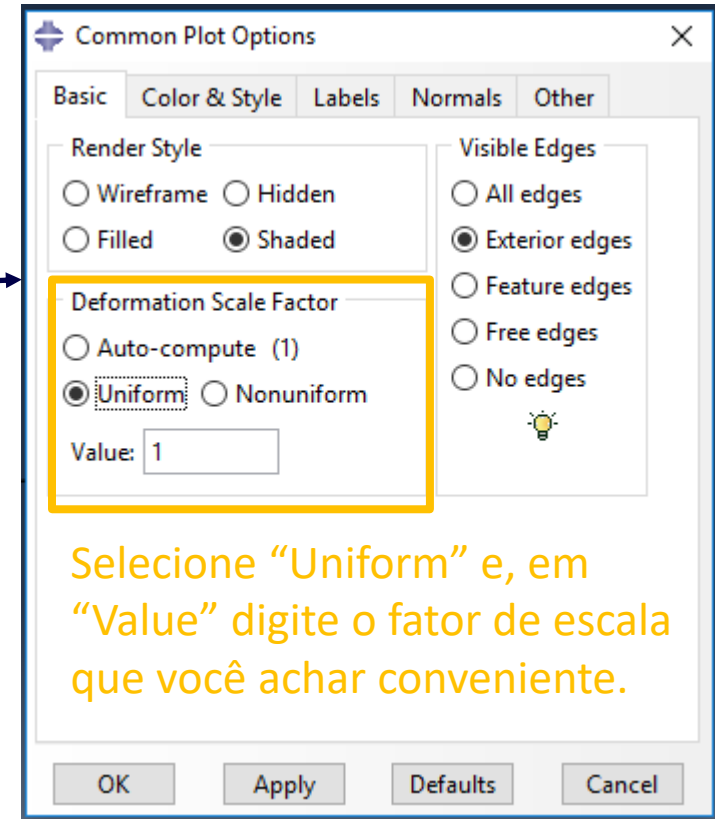
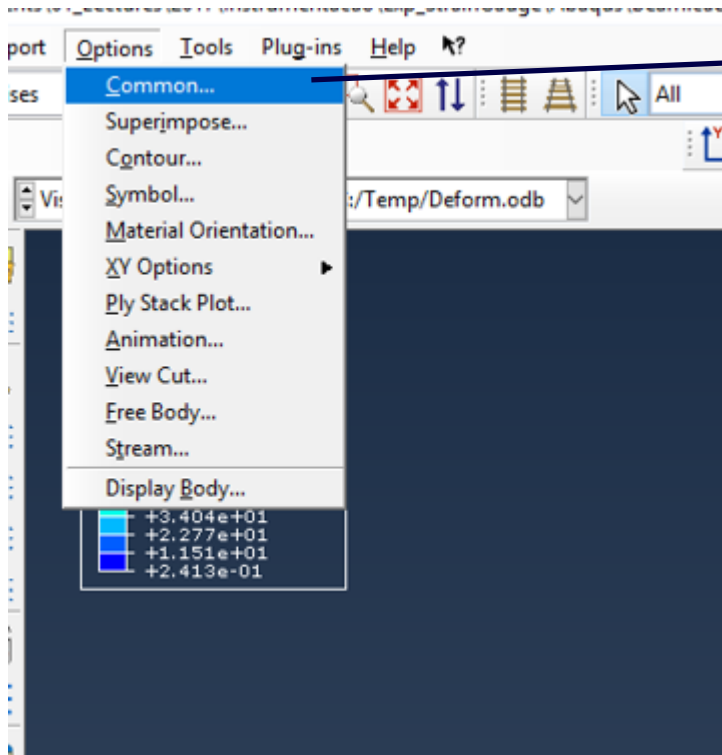



FIM