

Alto Forno

Parte 1

Fluxograma parcial de uma usina integrada até o Alto Forno

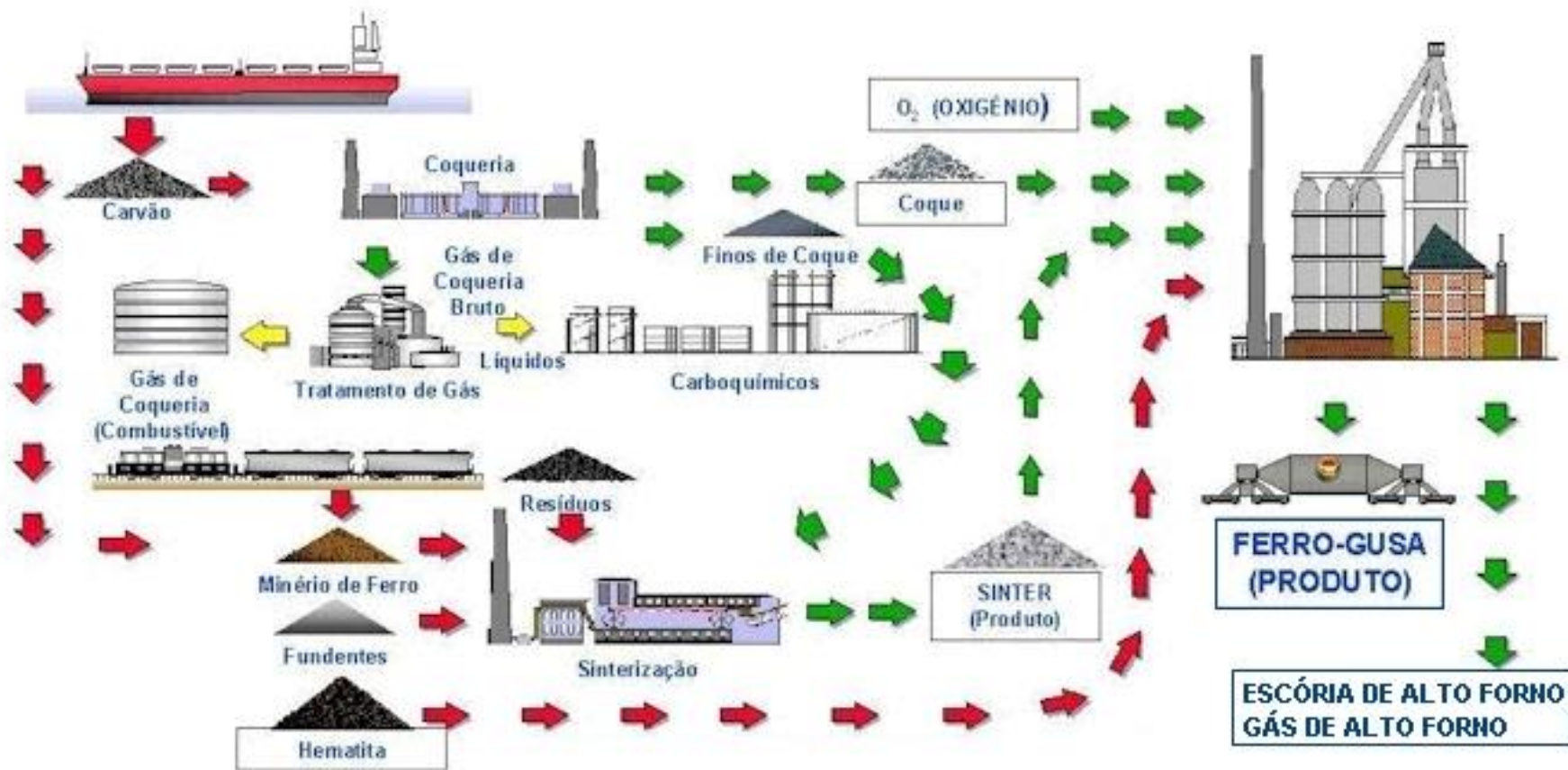

alto forno: primeiro estágio na produção de aço a partir dos óxidos de ferro

primeiros altos fornos >>século 14 >> 1 tonelada de ferro gusa / dia

atualmente: 13.000 toneladas por dia

alto forno: sistema destinado a produzir ferro gusa em estado líquido a uma temperatura em torno de 1500°C, com a qualidade e em quantidade necessárias para o bom andamento dos processos produtivos subsequentes

matérias primas básicas (carregadas pelo topo do forno):

- carga metálica (sinter, pelotas, minério granulado)
- combustível sólido (coque ou carvão vegetal)
(pode haver injeção de combustíveis auxiliares pelas ventaneiras)
- fundentes

Reator mais complexo da metalurgia

- 3 estados da matéria: sólidos, líquidos e gases
- centenas de reações
- grandes gradientes de temperatura, (mais de 2000 °C em frente as ventaneiras, cerca de 150 °C no topo)
- grande fluxo de gases

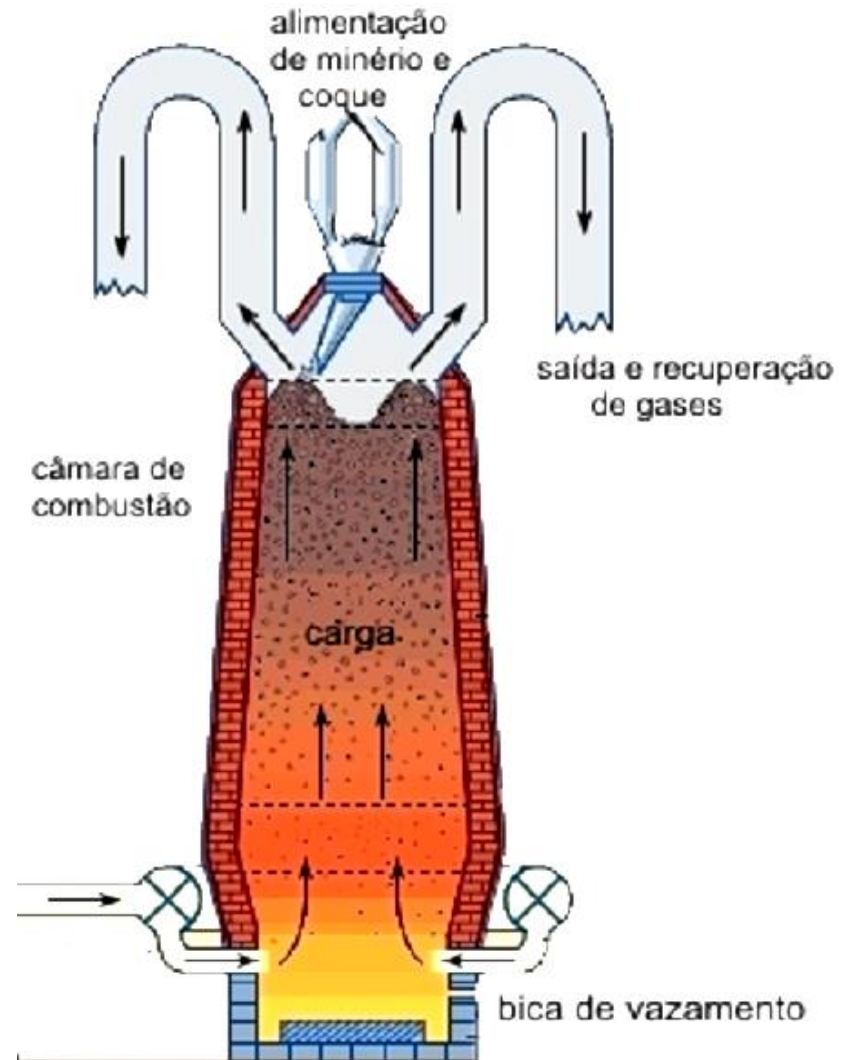

Esquema simplificado do alto forno, indicando os principais equipamentos

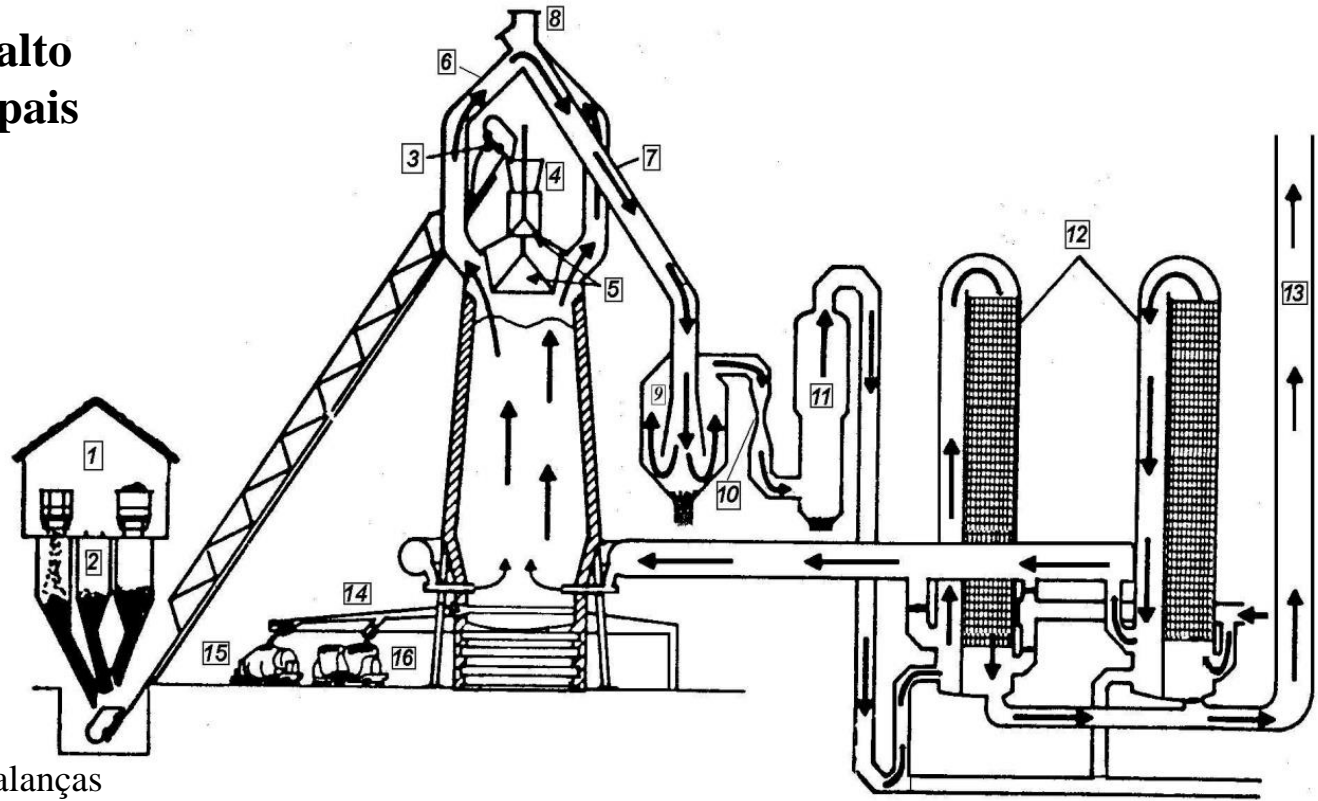

“casa de silos” (1)

silos separados (2) equipados com balanças

carro “skip” (3) ou correia transportadora

tremonha de recebimento no topo do forno (4)

cones (5), responsáveis pela selagem dos gases e pela distribuição dos materiais na “goela” do forno.

“uptakes” (6), o gás quente e sujo de pós deixa o forno e flui para cima

“downcommer” (7)

válvulas “bleeders” (8) cuja função é permitir a liberação do gás e proteger o topo no caso de uma súbita elevação de pressão do gás

coletor de pó (9)

venturi” (10), onde são removidas as partículas mais finas na forma de lama.

desumidificador (11) cuja função é reduzir o teor de umidade do gás.

regeneradores (12)

chaminé (13).

o gusa e a escória são separados por diferença de densidade no canal principal (14)

carros torpedos (15)

potes de escória (16)

Primeiro alto-forno

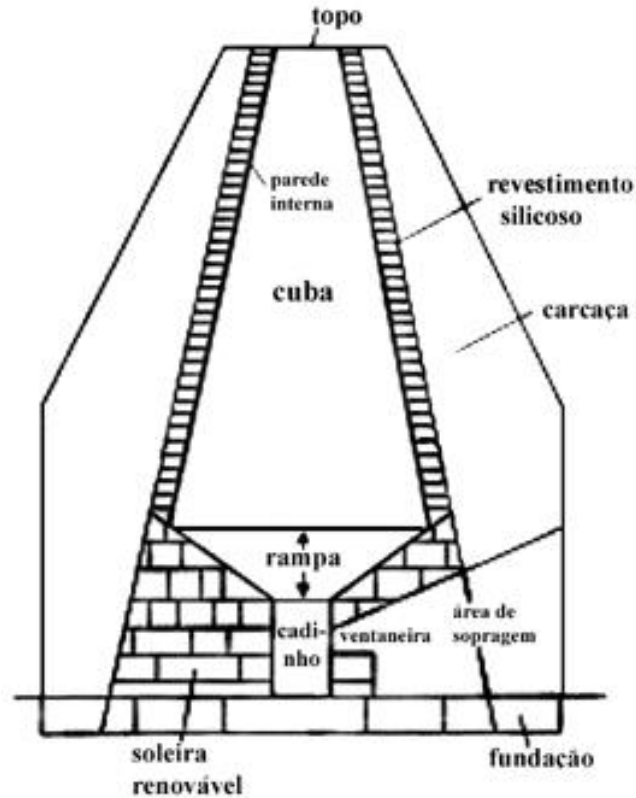

Brescia, 1450

Inglaterra- AF a coque

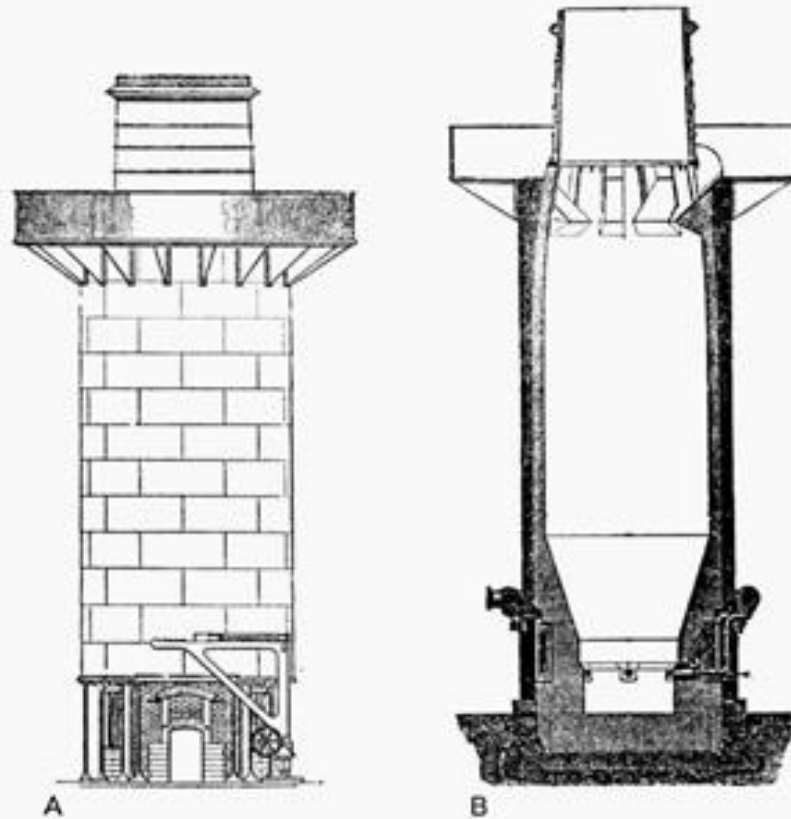

FIGURE 65—Blast furnace of the Dundivan type at Russel's Hall near Dudley, Worcestershire. (A) Front elevation, (B) vertical section. The crane shown in (A) was used to remove the large cake of slag that formed.

Sec. XIX

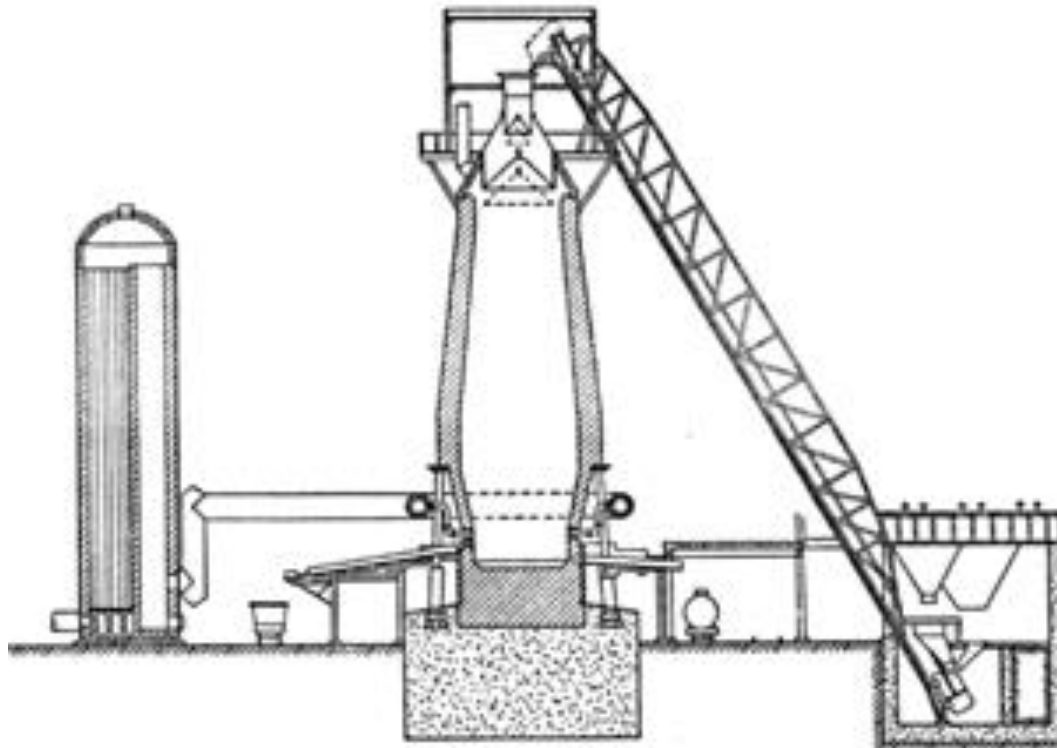
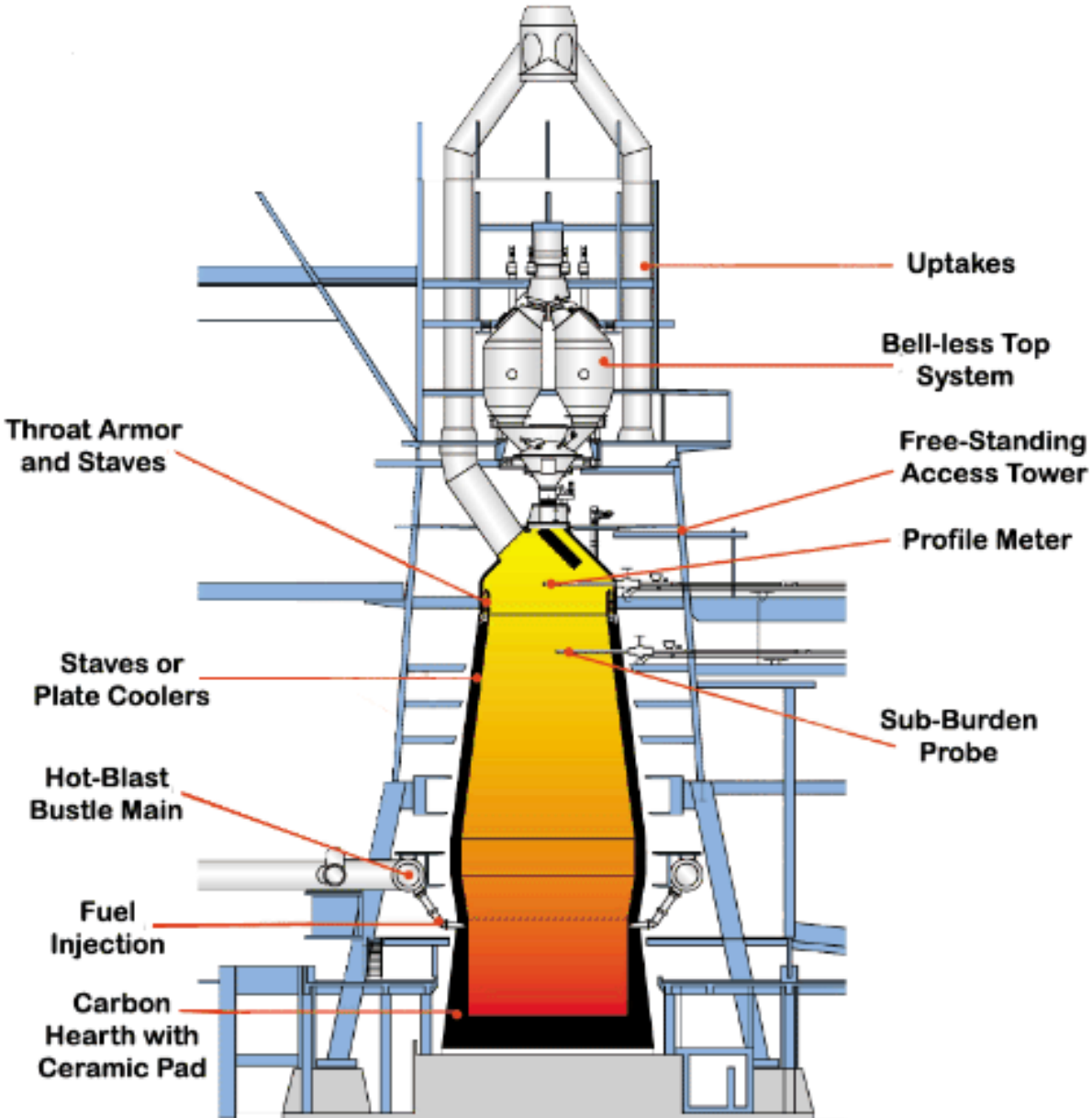
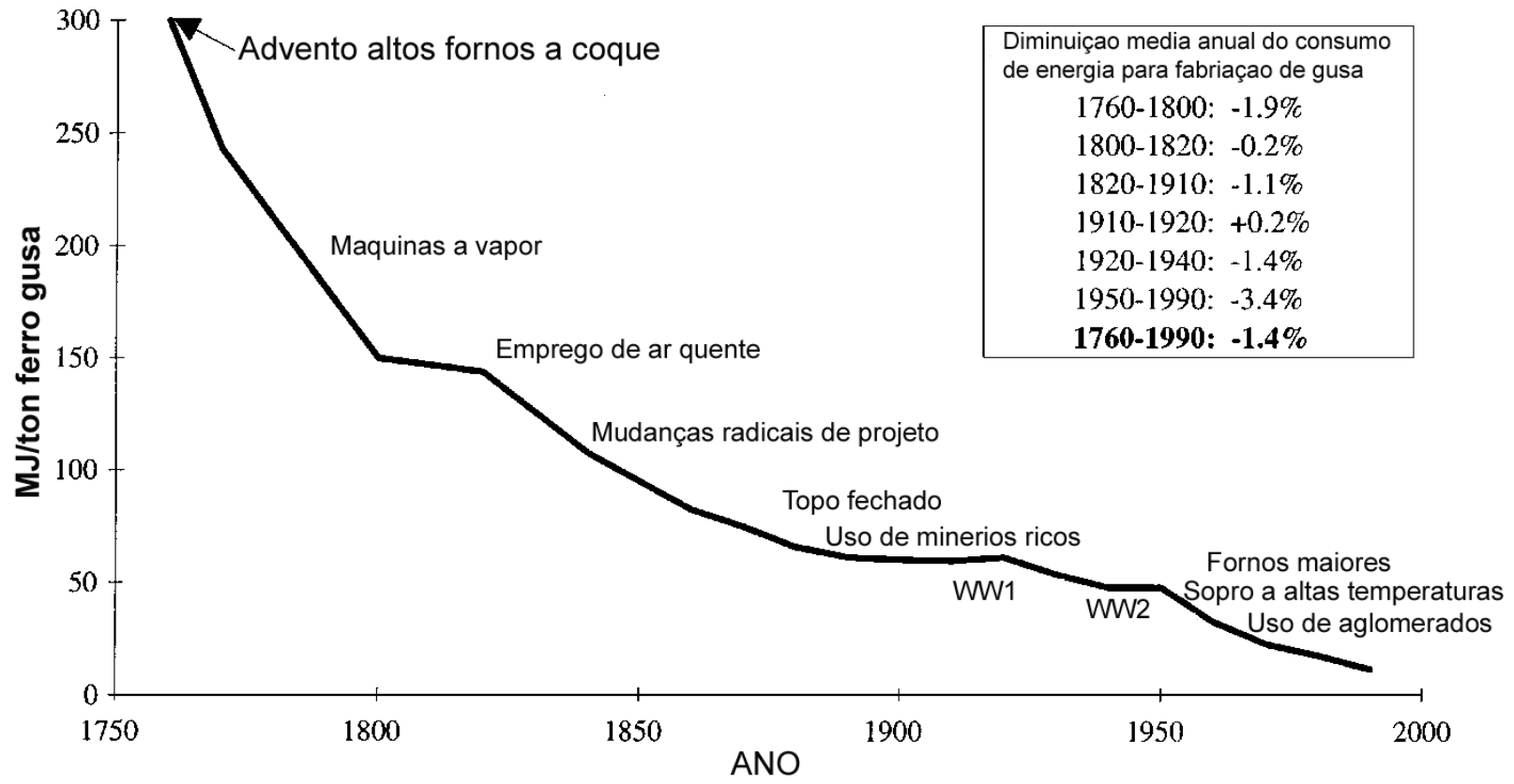

FIGURE 23—*Blast furnace (centre), stove for production of hot blast (left), and ramp for raising the charge of coke and ore (right). The slag was discharged to the left and the iron to the right.*

Hoje





300

250

200

150

100

50

0

1750

1800

1850

1900

1950

2000

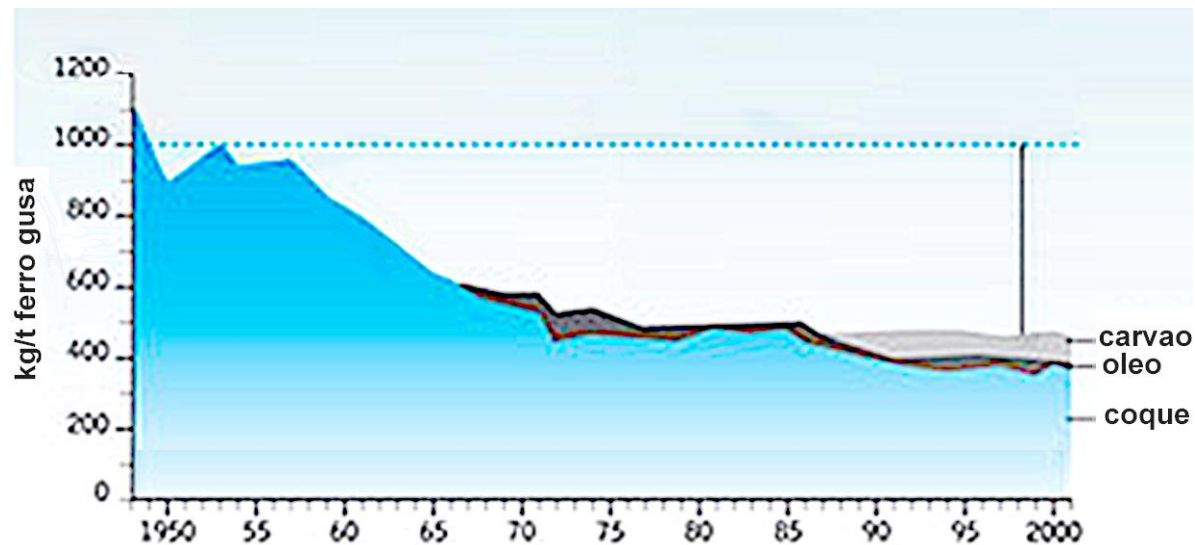
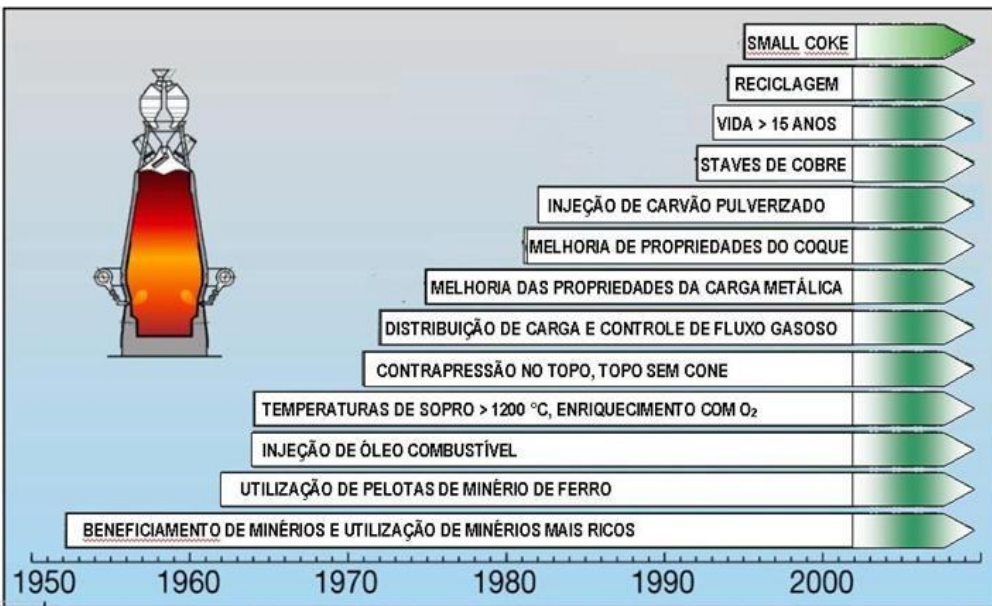

Melhores praticas
em
Altos Fornos

carbono do gusa: **174 kg CO₂ / t HM**
gas exportado: **888 kg CO₂ / t HM**
regeneradores: **427 kg CO₂ / t HM**
Total : **1489 kg CO₂ / t HM**

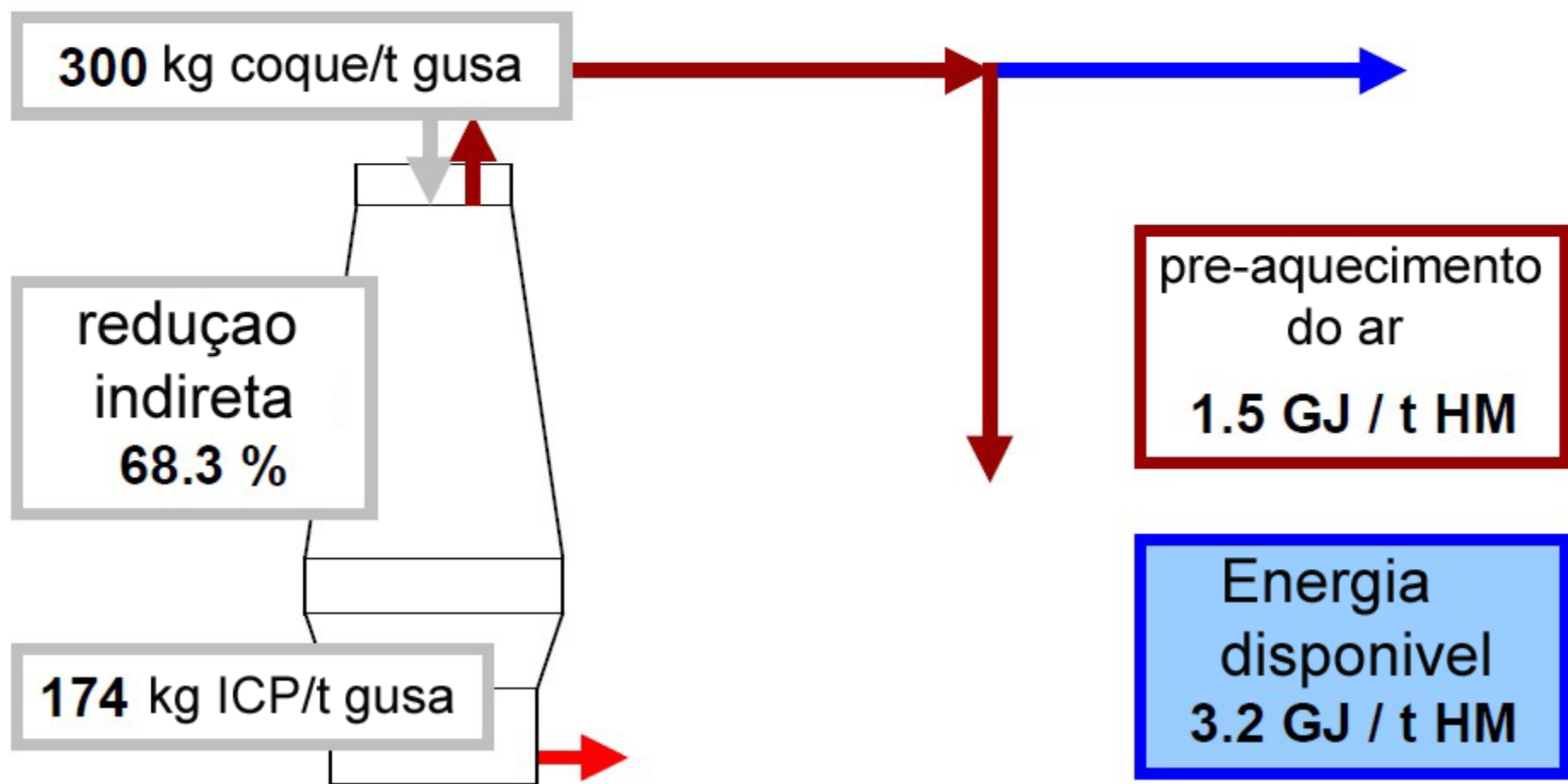

Produtos do Alto-Forno

Ferro gusa :

- 4,5 % Carbono
- 0,4% Silício
- 0,3% Manganês
- 0,1 % Fósforo
- 0,03% Enxôfre

Temperatura: 1400-1500 C

Escória: $\text{SiO}_2\text{-CaO-Al}_2\text{O}_3$

Gás: $\text{CO-CO}_2\text{-N}_2$

Regiões do AF

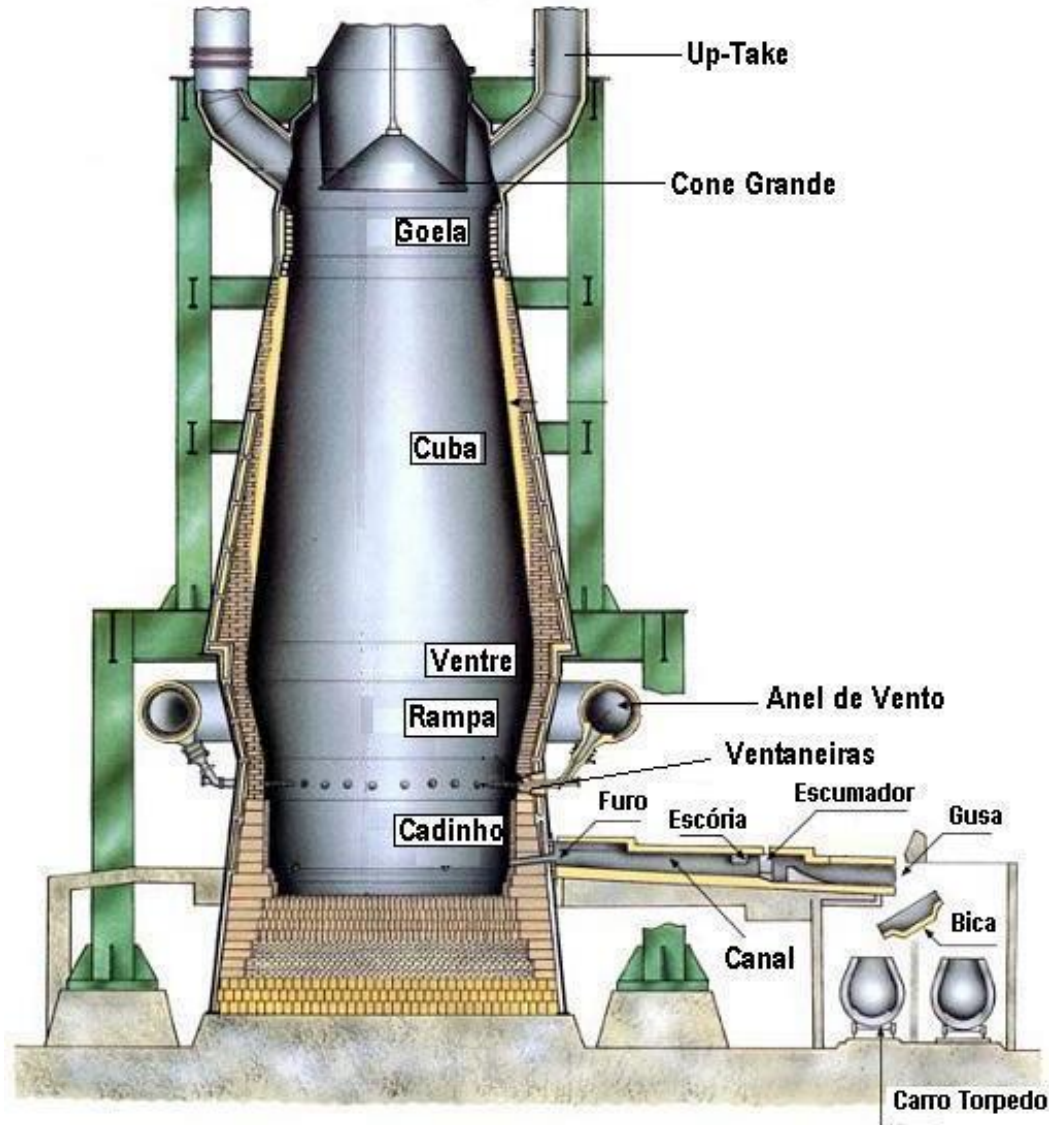

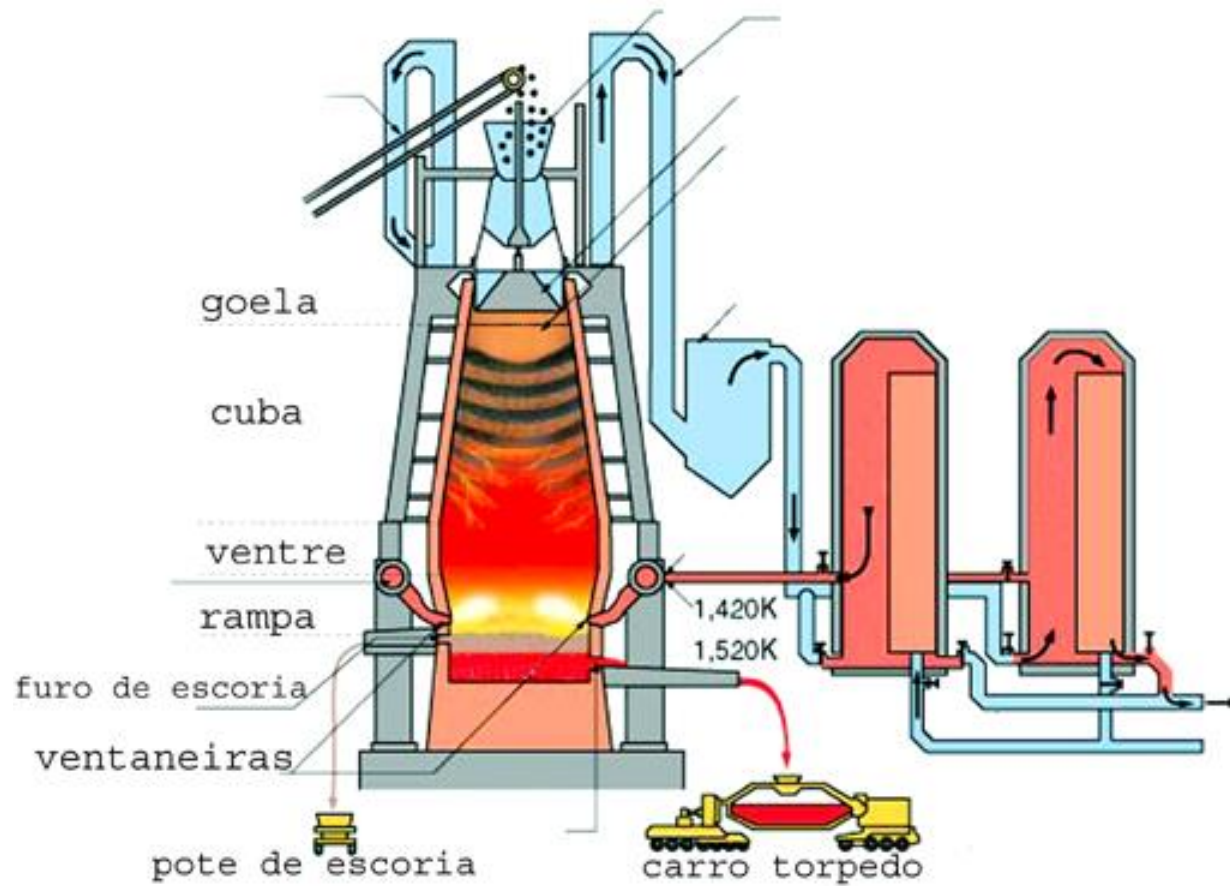





Reator a contra-corrente

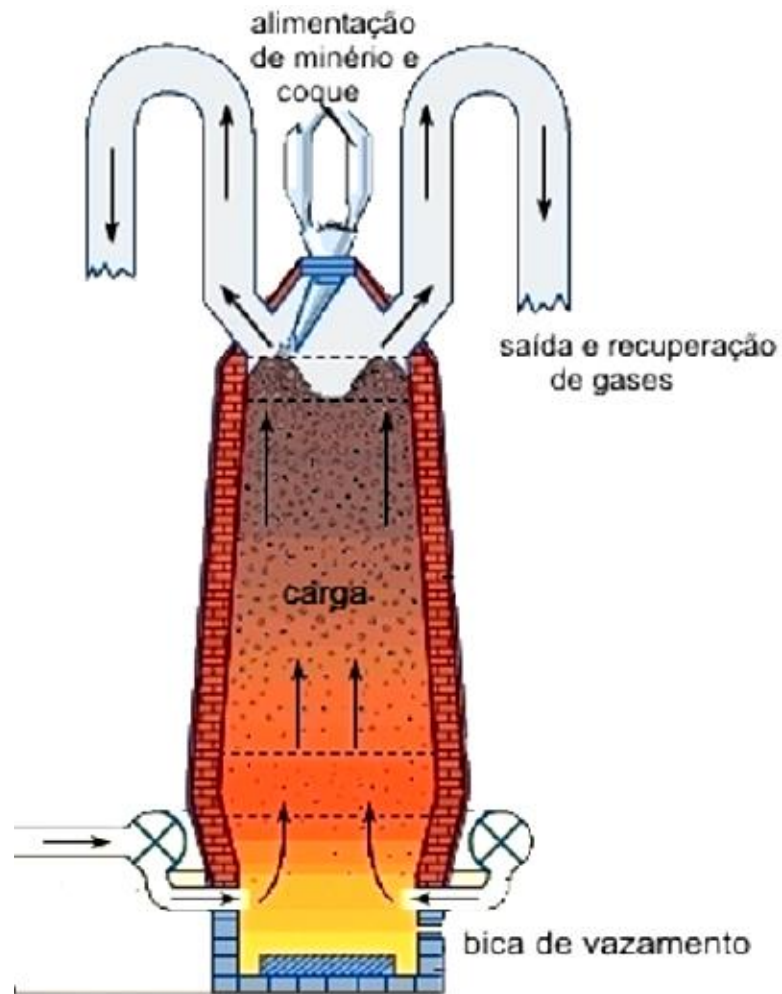

Zonas Internas

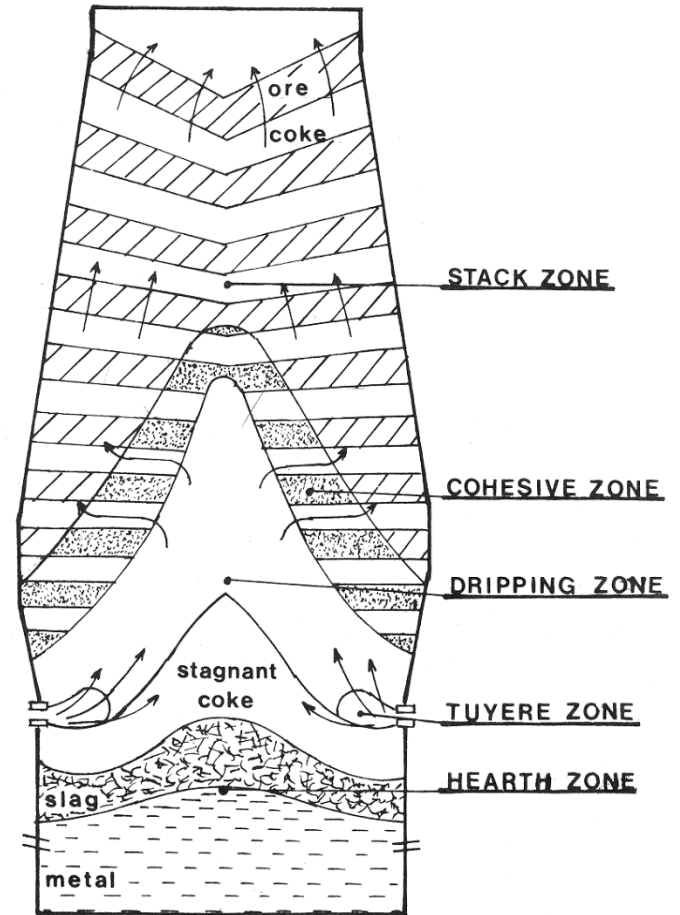
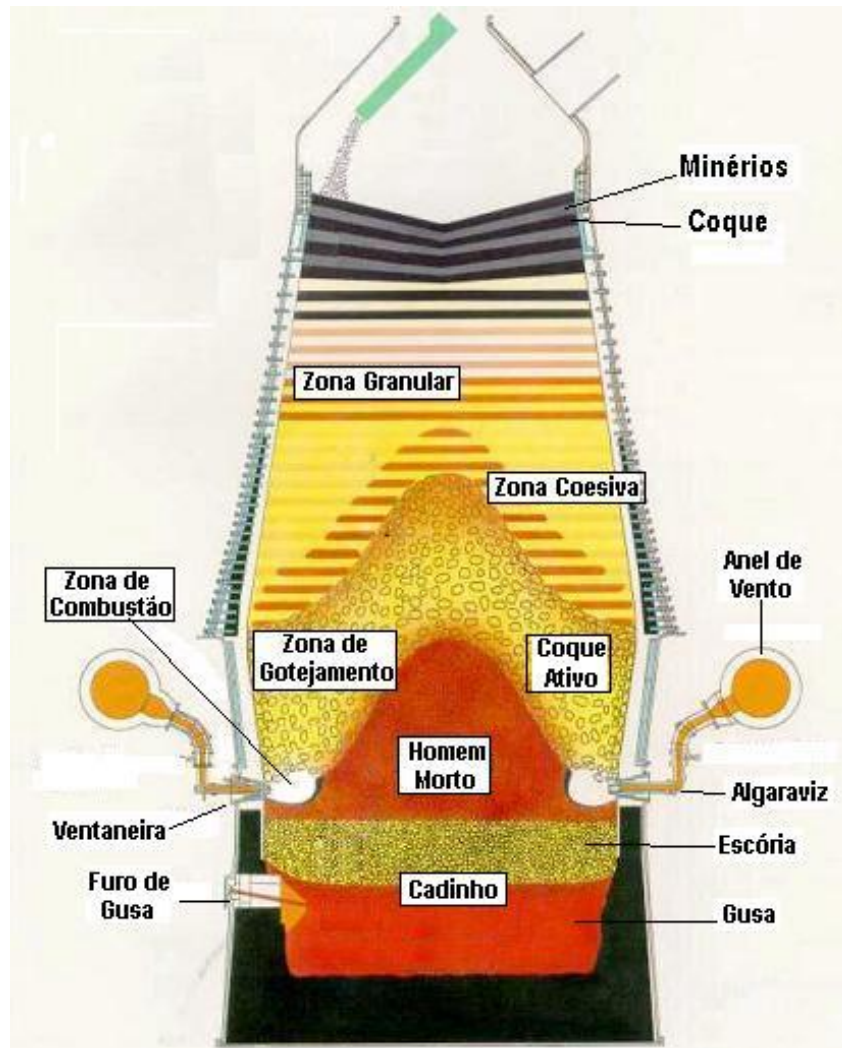

Reações

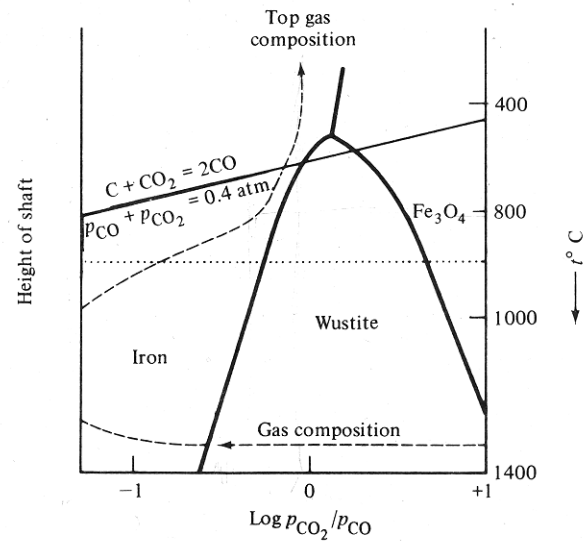
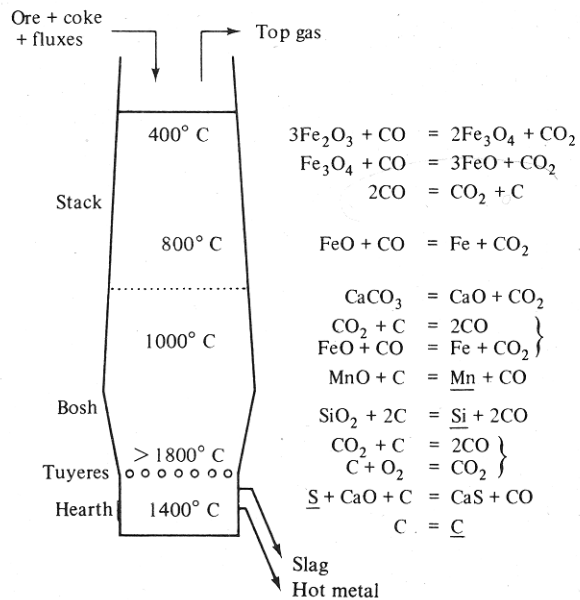

Carregamento

Skip: até 15 m^3 ; para af
pequenos, até 3.000 t/dia

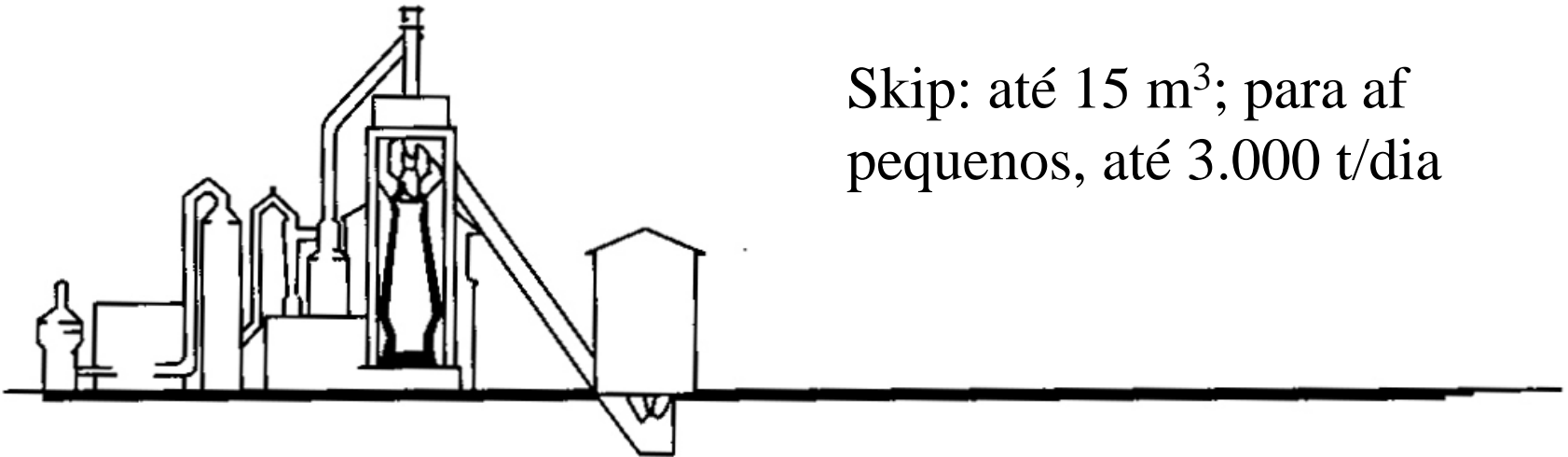

(a) Skip-fed blast furnace

Esteira ou correia; carregamento
contínuo; inclinação máxima de 15° ;
velocidade 1 a 3 m/s, largura $\sim 1 \text{ m}$.

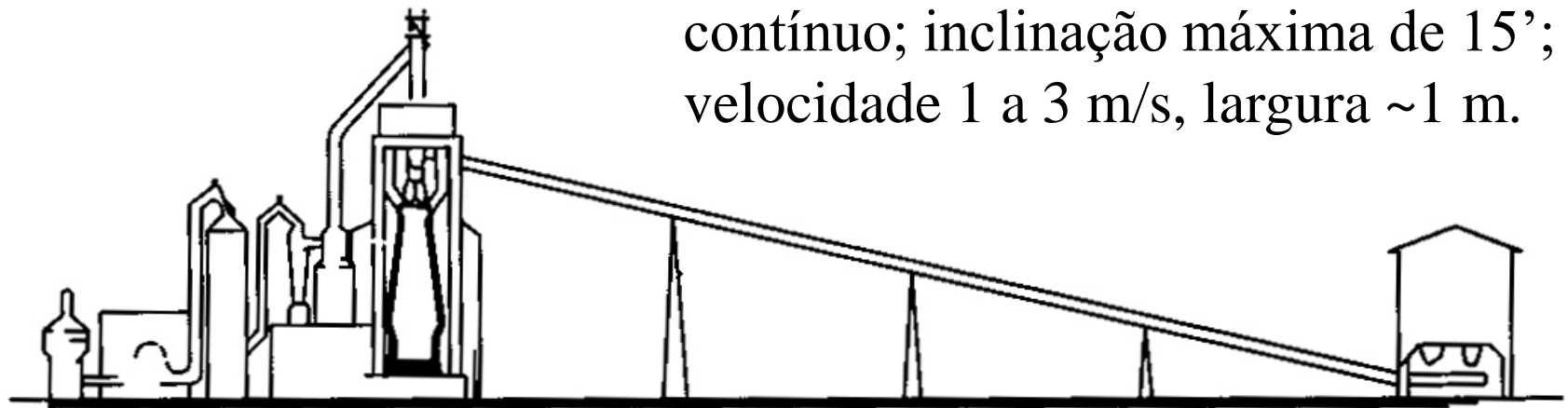

(b) Conveyor-fed blast furnace

Methods for delivering raw materials to the furnace top.

Carregamento-pesagem

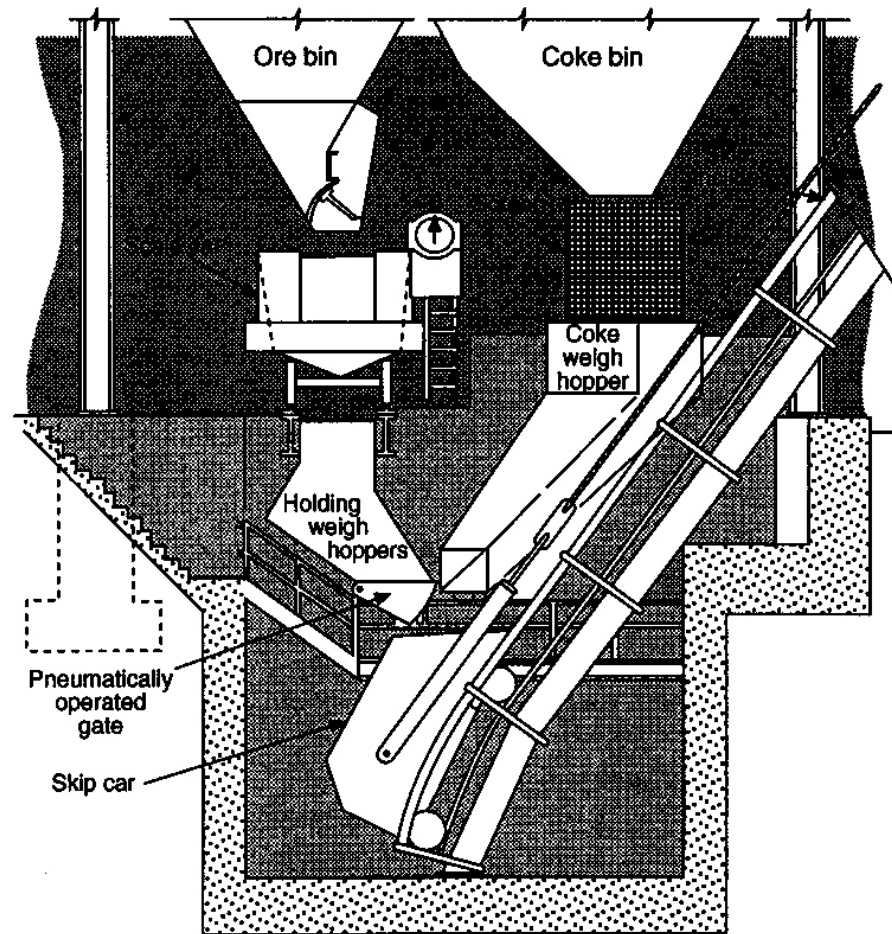

Typical scale car stockhouse.

Carregamento

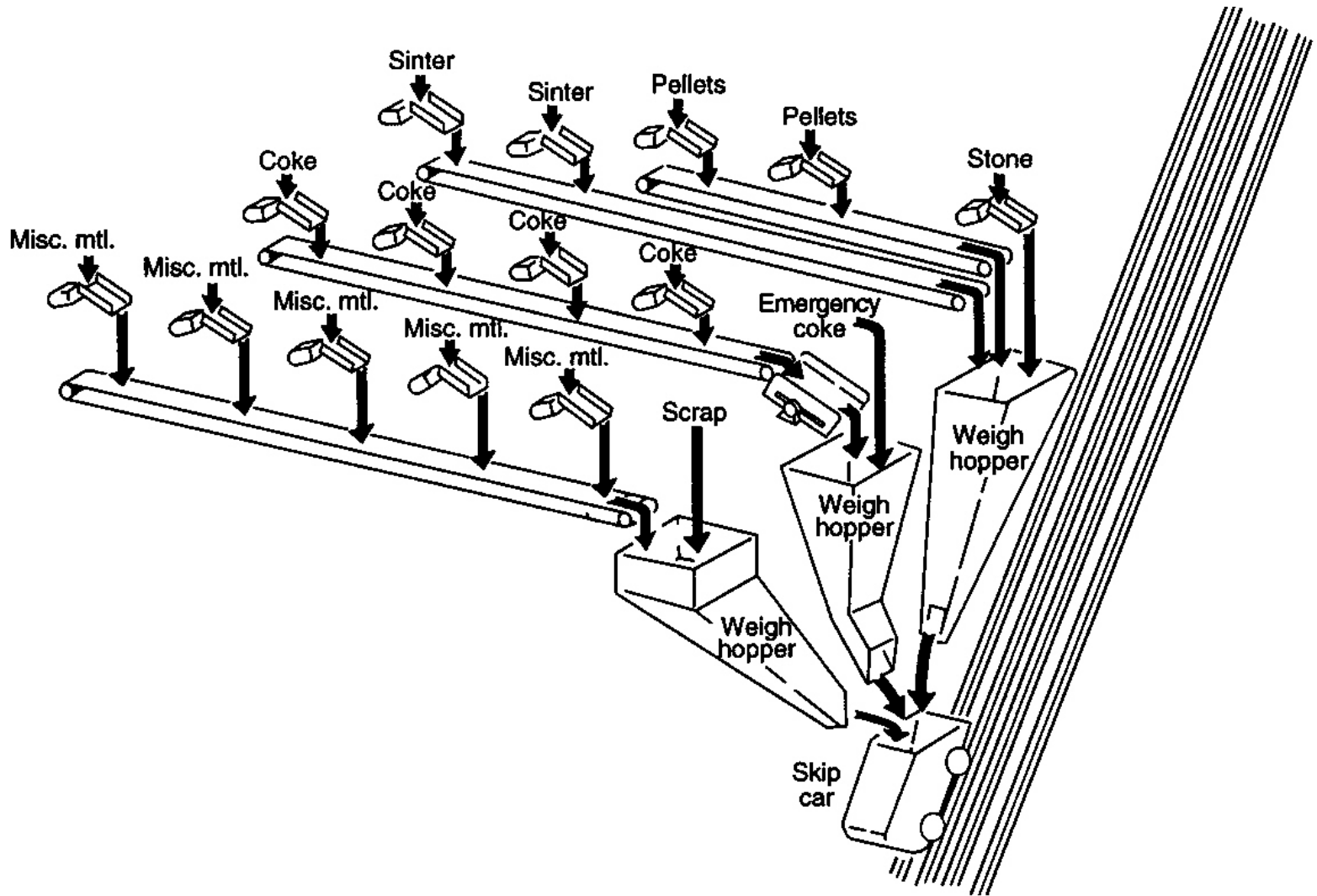

Simplified schematic of an automated stockhouse for a skip-fed furnace.

Topo- Duplo cone

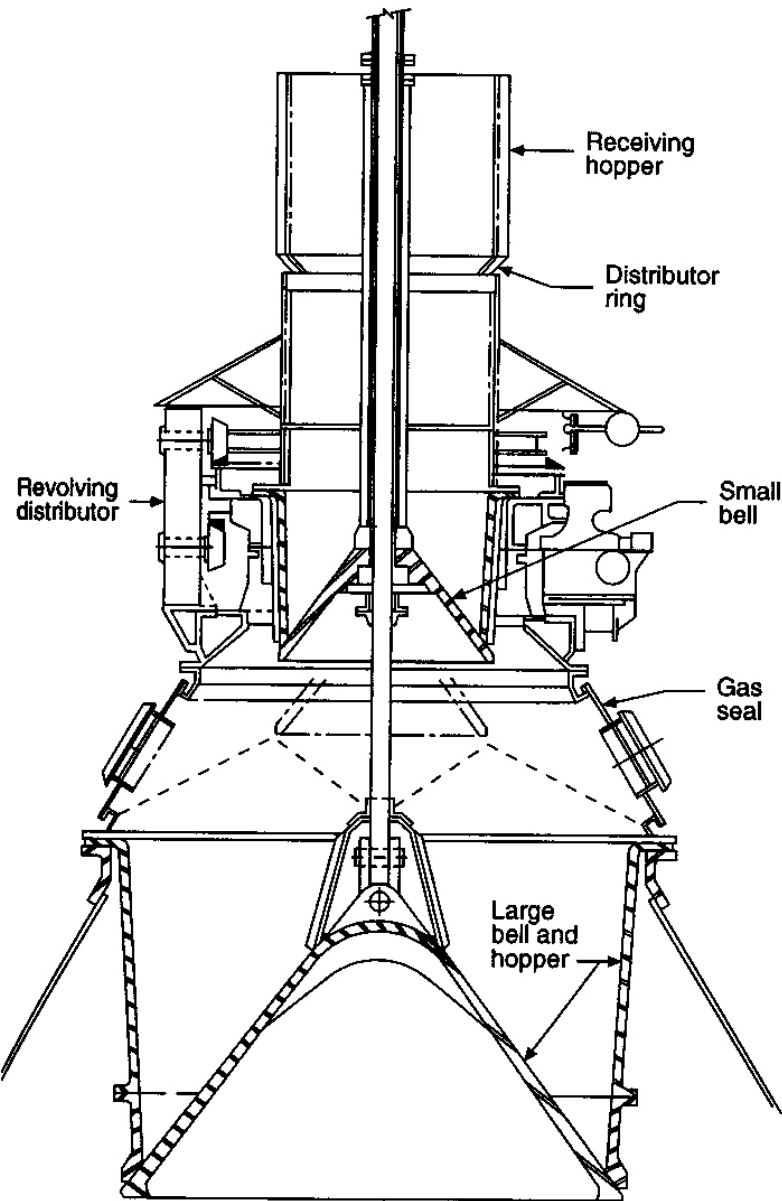

Schematic of a typical two-bell top.

Topo-Duplo cone

Fig. 9.23 Progressive steps by which the two-bell top permits charging of materials to the blast furnace without escape of process gases.

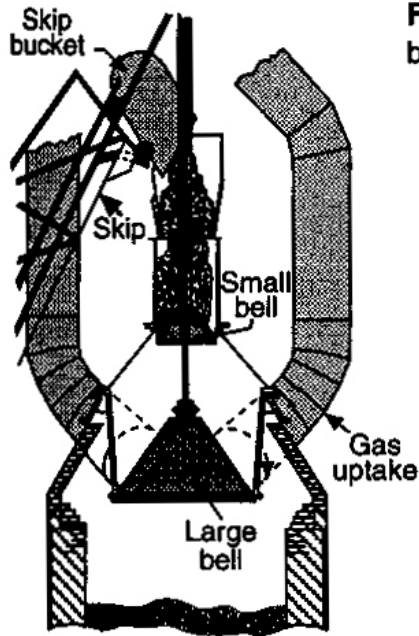

Small bell and large bell both closed, skip bucket tipped to dump charge in hopper above small bell. Gas flowing from top of furnace through uptakes located in dome (top cone).

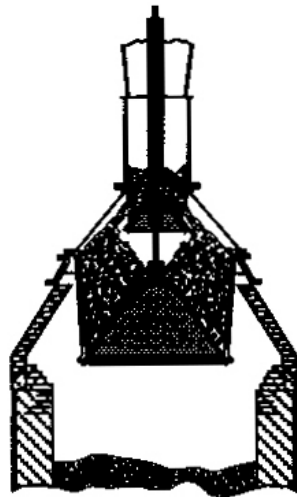

Large bell remains closed while small bell opens to admit charge to large bell hopper.

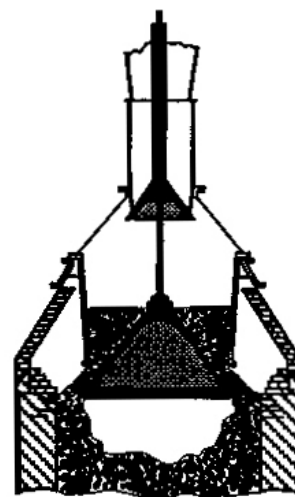

Small bell closed to prevent escape of gas to atmosphere and large bell open to admit charge to the furnace.

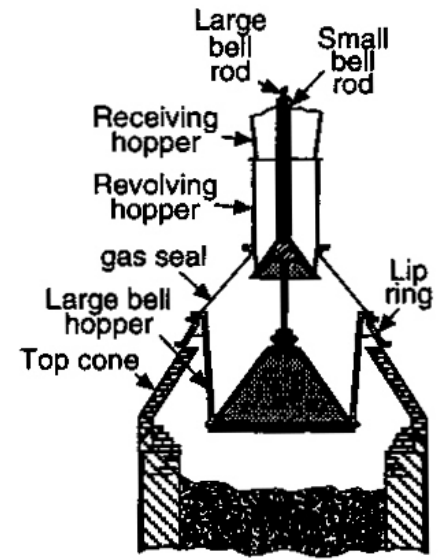

Both bells closed, ready to repeat charging cycle. Note that rod supporting large bell passes through hollow rod supporting small bell, permitting independent operation of bells.

Topo- Duplo cone

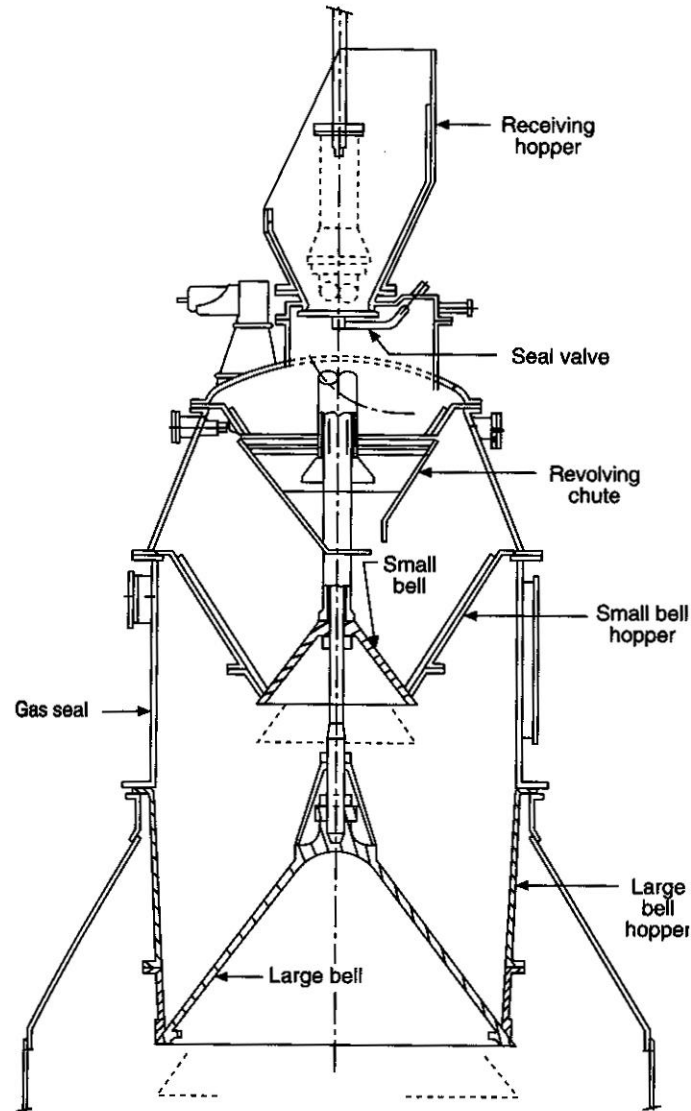

Schematic of two-bell top with seal valves and a revolving chute.

Armadura móvel

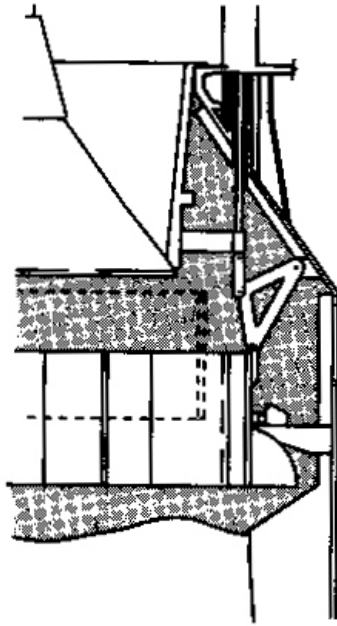

(a) Adjustable conical armor

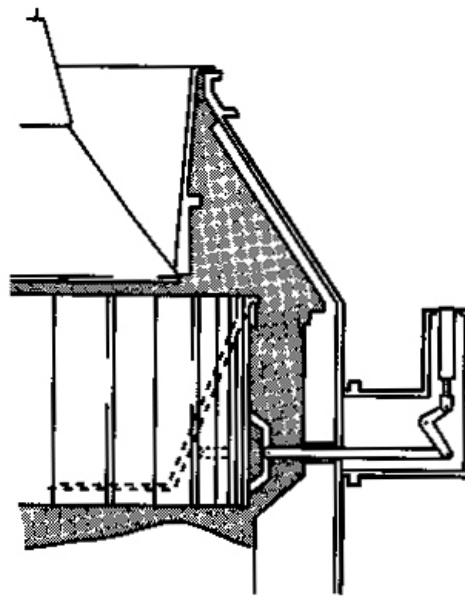

(b) Adjustable cylindrical armor

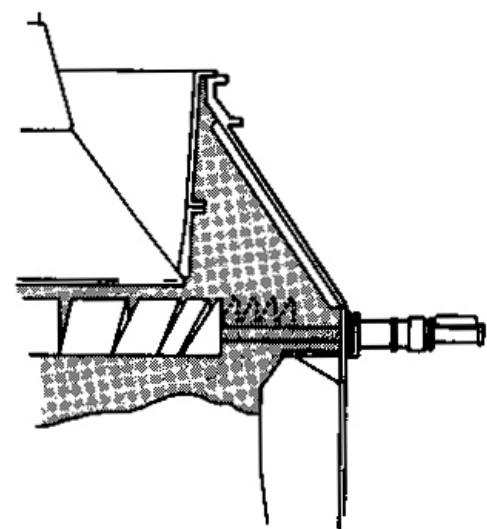

(c) Deflector plate armor

Types of adjustable throat armor used to control burden distribution.

Topo sem cone- calha rotativa-Paul Wurth

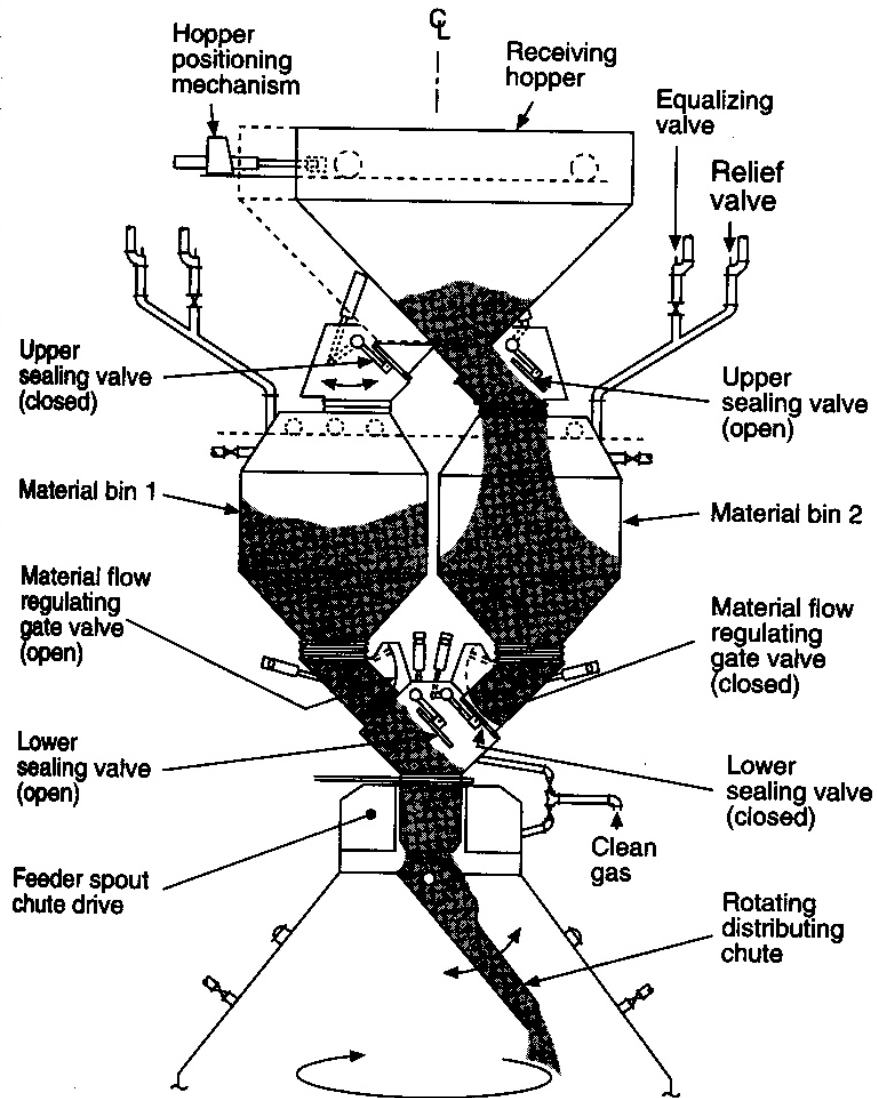

Schematic of a bell-less top with pressurized hoppers and a rotating distributing chute.

Topo sem cone

Refinement of the bell-less top equipment to reduce the segregation of fines.

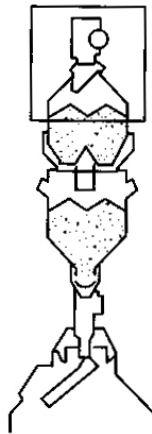

(a) Multiple - port vertical two-hopper type

Area enlarged

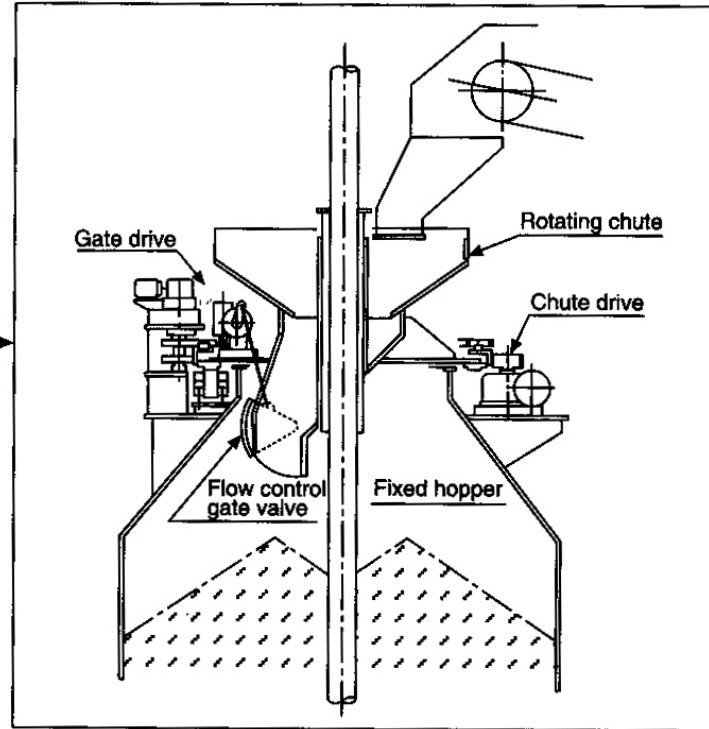

(b) Flow control gate valve of rotating chute

Equema de topo de forno equipado com calha rotativa e equipamento auxiliares

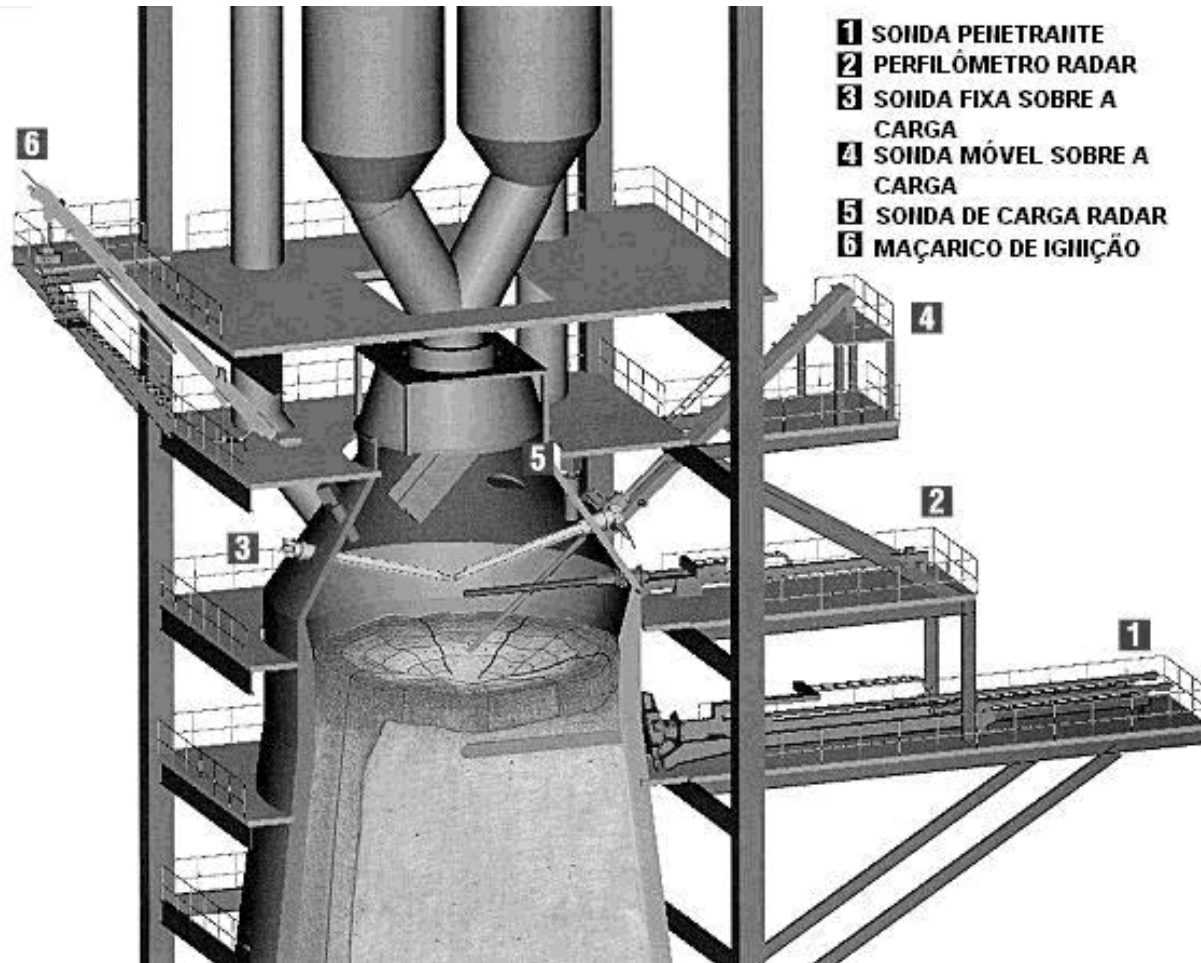

Desenho esquemático da Armadura Móvel e da Calha Rotativa

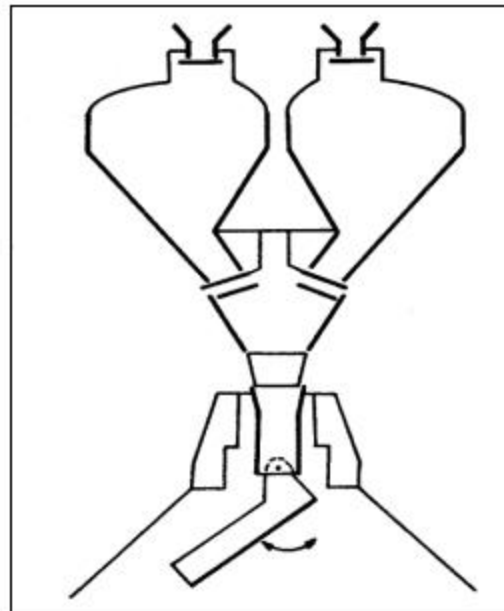
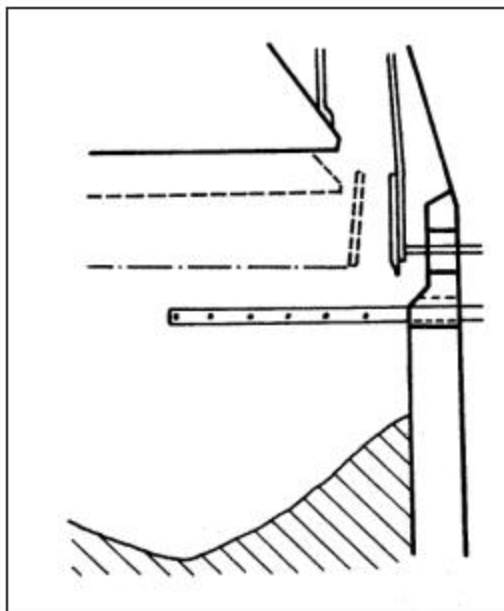

Sistema de gases

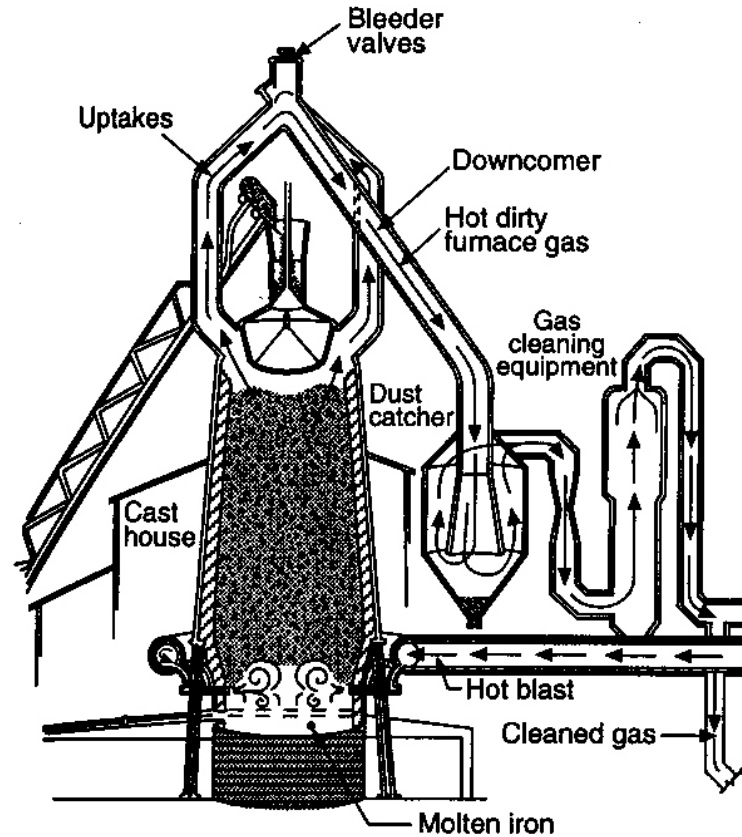

General arrangement of blast furnace gas equip-

Gás de saída do alto forno: 10 a 40 g de partículas finas por Nm^3 , dos quais ~ 35 % pó de coque.

Limpeza de gases-coletor de pó

O coletor de pó separa partículas maiores que 0,8 mm, gerando um resíduo, o pó de coletor, que contém carbono e óxidos de ferro, principalmente.

O gás sai com ~ 150 mg pó/m³ de gás.

Gera-se 10 a 15 kg pó/ton gusa

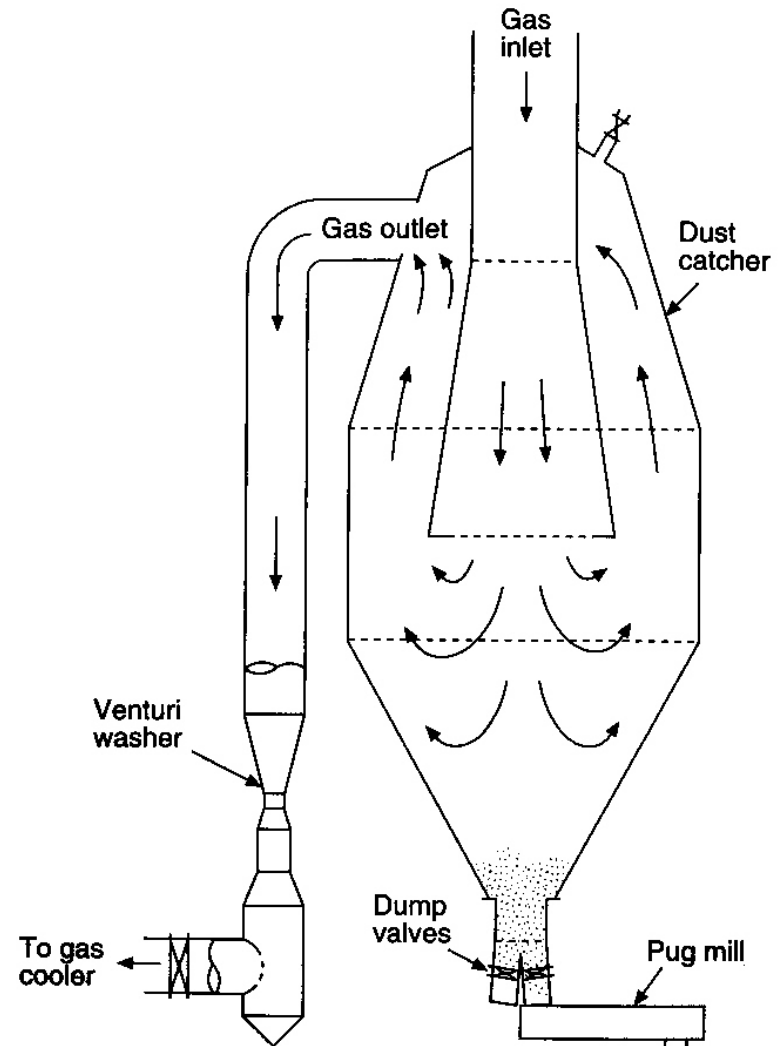

Schematic of a dustcatcher and a venturi washer.

Limpeza de gases-venturi

Após o despoeiramento (lavagem) no venturi, o gás contém $\sim 10\text{mg/m}^3$ poeira, podendo chegar a 6 mg/m^3 com o venturi de 2 estágios.

O pó fica na água; através de espessadores ou de filtros, separa-se grande parte da água, obtendo-se uma lama com $\sim 25\%$ água, que pode ser reciclada.

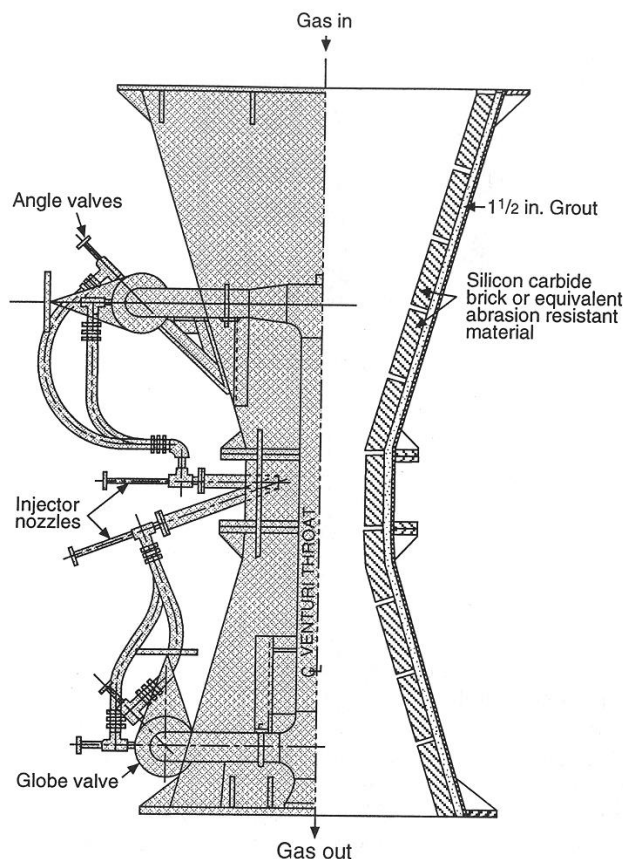

Schematic arrangement of a venturi-type unit for washing blast furnace gas; at right is a cut-away drawing to show the lining.

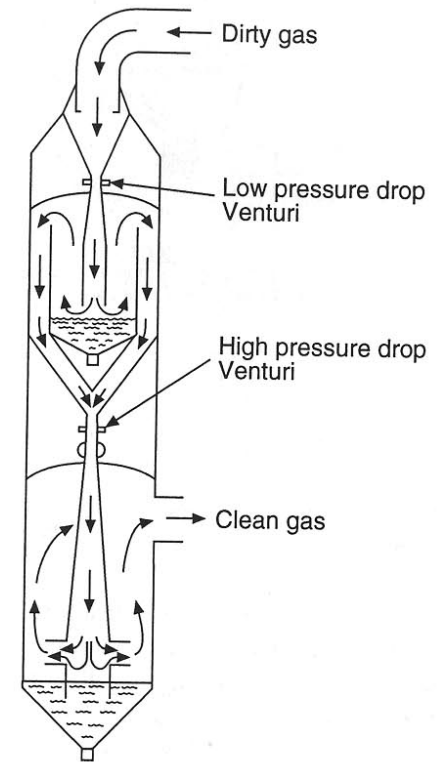

Schematic of an automatic two-stage venturi gas washer that controls blast furnace top pressure.

Esquema mostrando um tipo de sistema de limpeza de gases ao alto forno

O gás é desumidificado e armazenado em gasômetro para uso posterior como combustível.

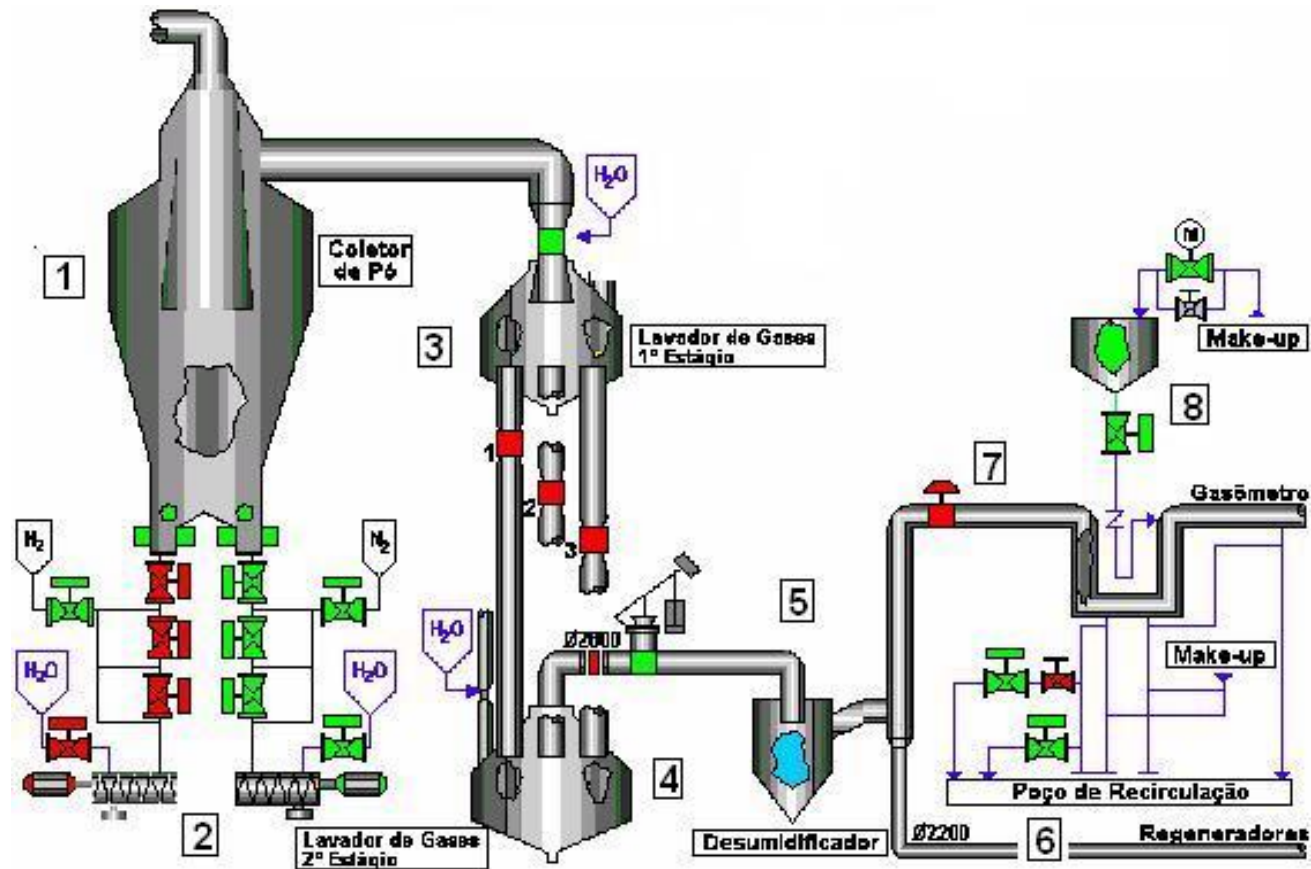

Pré-aquecimento de ar-regeneradores

Têm por função aquecer o ar injetado através das ventaneiras para a combustão do coque. O regenerador recebe o ar na temperatura entre 150 a 200 °C, chamado ar frio, e eleva esta temperatura para a faixa de 1000 a 1250 °C, dependendo de sua capacidade, passando a ser chamado de ar quente.

Combustível utilizado: gás misto, mistura de gases provenientes do próprio alto forno (86 a 94% de GAF) e da coqueria (14 a 6% de GCO).

A câmara de combustão tem grande altura e diâmetro, para evitar o impacto da chama no domo e para alargar mais a chama.

Dimensões típicas: 10,4 m diâmetro, 40 m altura.

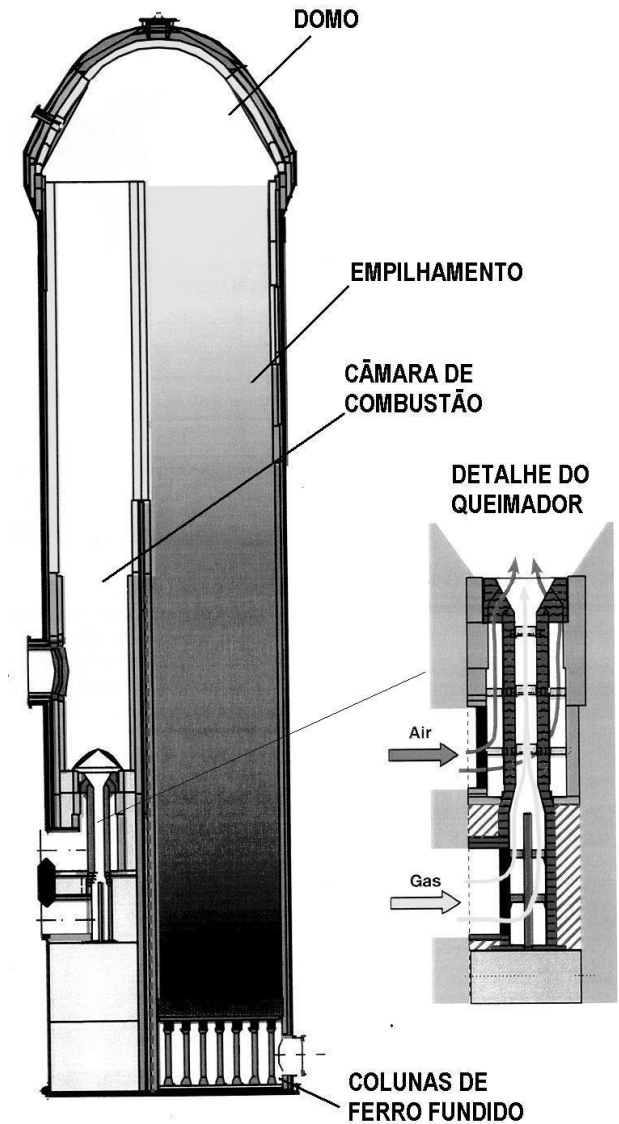

Esquema de um regenerador de alto forno

Domo é a parte superior do regenerador e tem por finalidade inverter em 180° o sentido dos gases queimados e distribuir os gases para o empilhamento de tijolos refratários, constituído de tijolos refratários perfurados, dispostos uns sobre os outros e que tem por finalidade absorver o calor na fase de aquecimento, com superfície de aquecimento no empilhamento de um regenerador normalmente excede 40.000 m².

Detalhes construtivos de um regenerador de alto forno

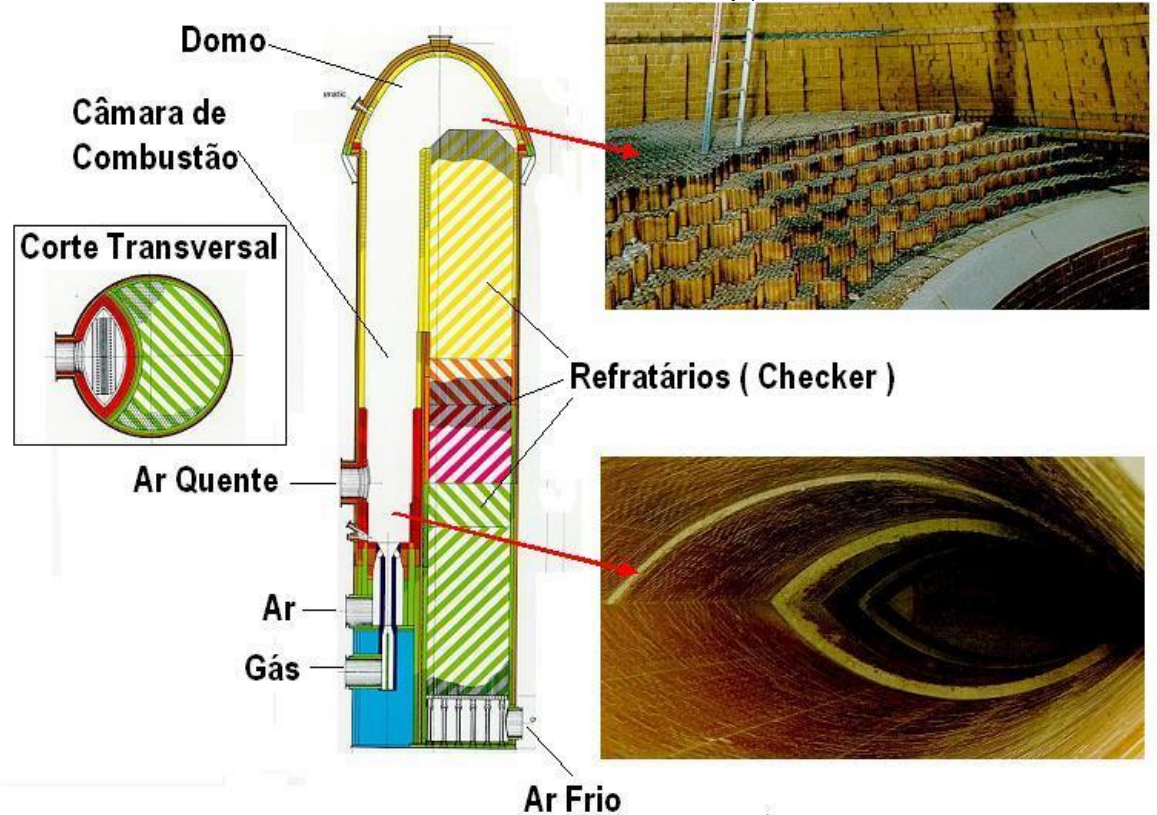

Além da superfície, é necessário que haja espessura de refratário suficiente para armazenar o calor. A relação área/peso varia entre 20 a 24 m²/t e a capacidade de armazenagem térmica/área varia entre 23 a 26,3 kJ/m² (5,5 a 6,3 Kcal/m²).

Os altos fornos possuem conjuntos de 3 ou 4 regeneradores que operam em ciclos.

Fases de um ciclo de operação de um regenerador

Aquecimento

Regenerador em combustão, aquecendo o empilhamento

Queima de mistura GAF-GCO; fumos liberados por chaminé

Sopro

Regenerador soprando ar quente para o alto-forno

Ar é injetado por turbo soprador na parte inferior, e deve vencer perda de carga do empilhamento, na tubulação e anel de vento, e através da carga do alto-forno, onde deve manter pressão de 1,5 atm. Pressão total de 6 atm

Abafado

Regenerador aquecido e isolado com todas válvulas fechadas

Manobrando

Fase intermediária entre todas as outras

Pré-aquecimento de ar-regeneradores

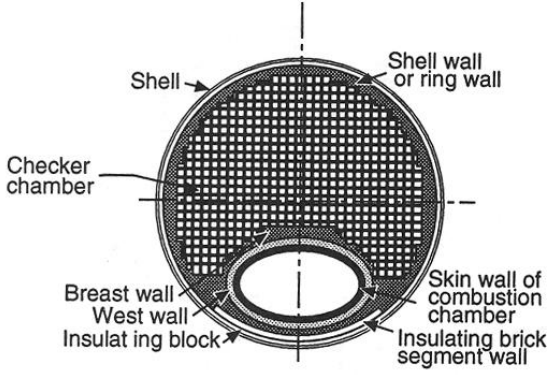

Cross-section of stove thru checkerwork

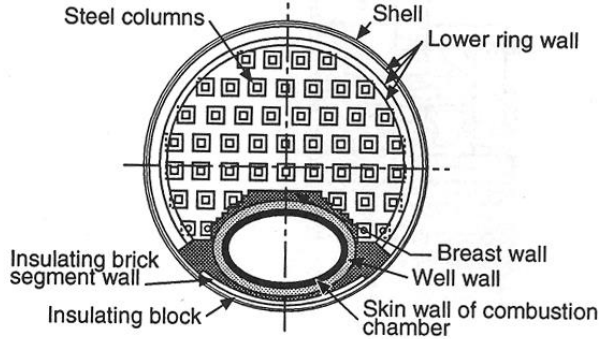

Cross-section of stove showing lower ring wall and checker supporting columns

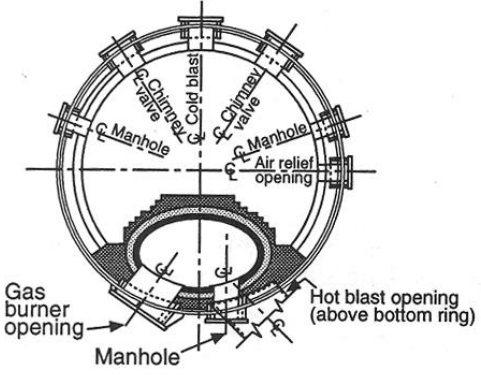

Cross-section of stove thru bottom ring showing stove equipment openings

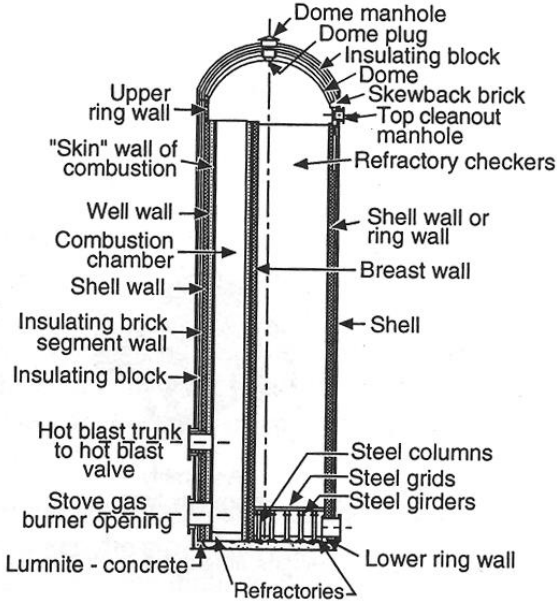

Vertical section through a stove with cross-sectional views at several elevations.

Enchimento dos regeneradores

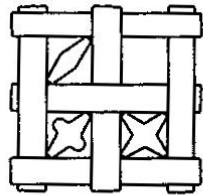

Old basket weave with different types of inserts

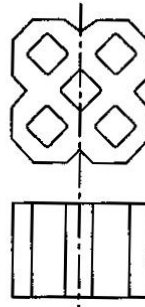

McKee type

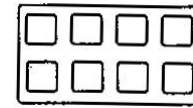

Simplex or Mohr type



Top

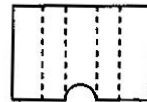

Elevation

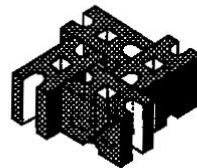

Assembly
Kennedy type

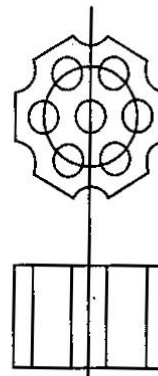

Freyn type

Different checker designs employed in blast furnace stoves. The basket weave design with inserts is no longer used.

Queimadores dos regeneradores

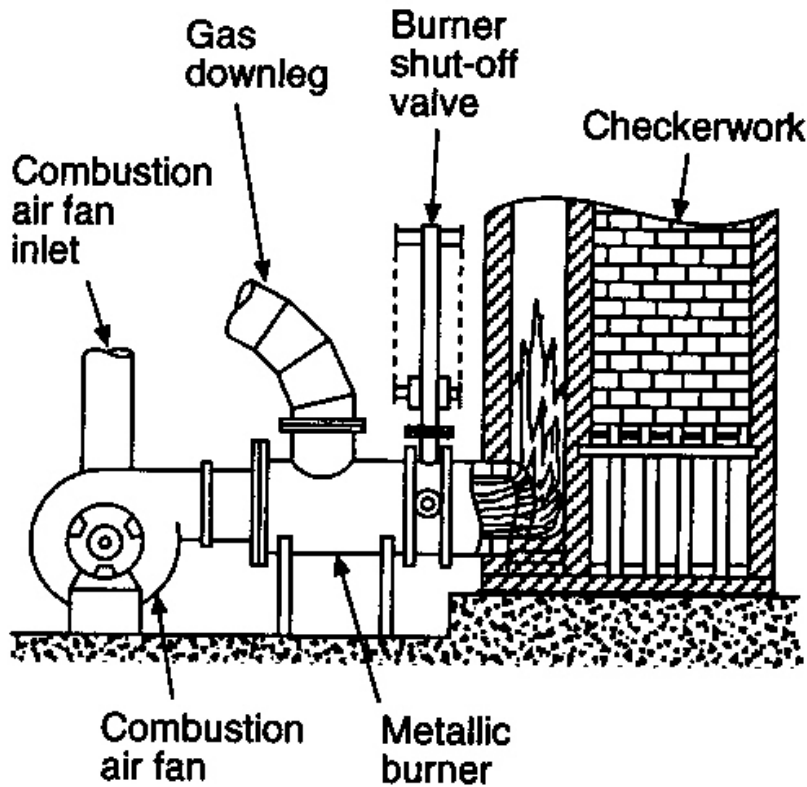

(a) Typical metallic burner

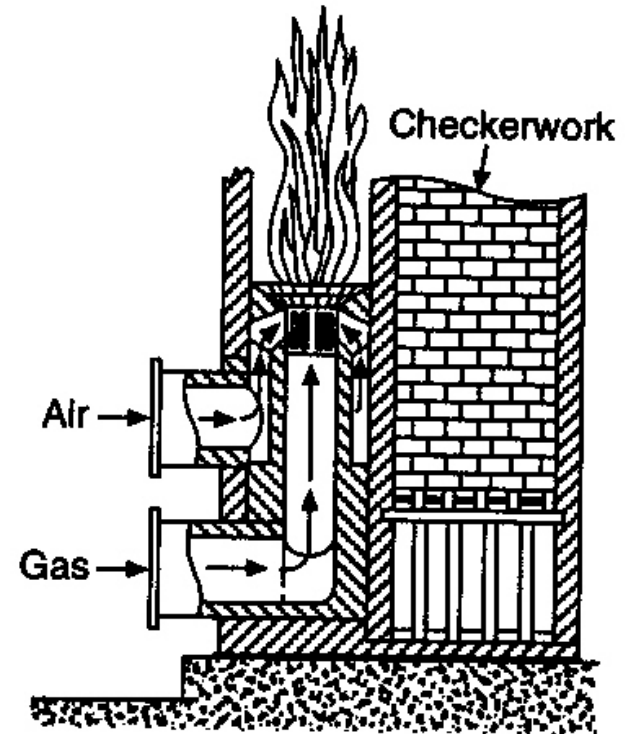

(b) Ceramic burner

Schematic of hot blast stove burners.

Regenerador com camara de combustão externa

Schematic of a hot blast stove with an external combustion chamber.

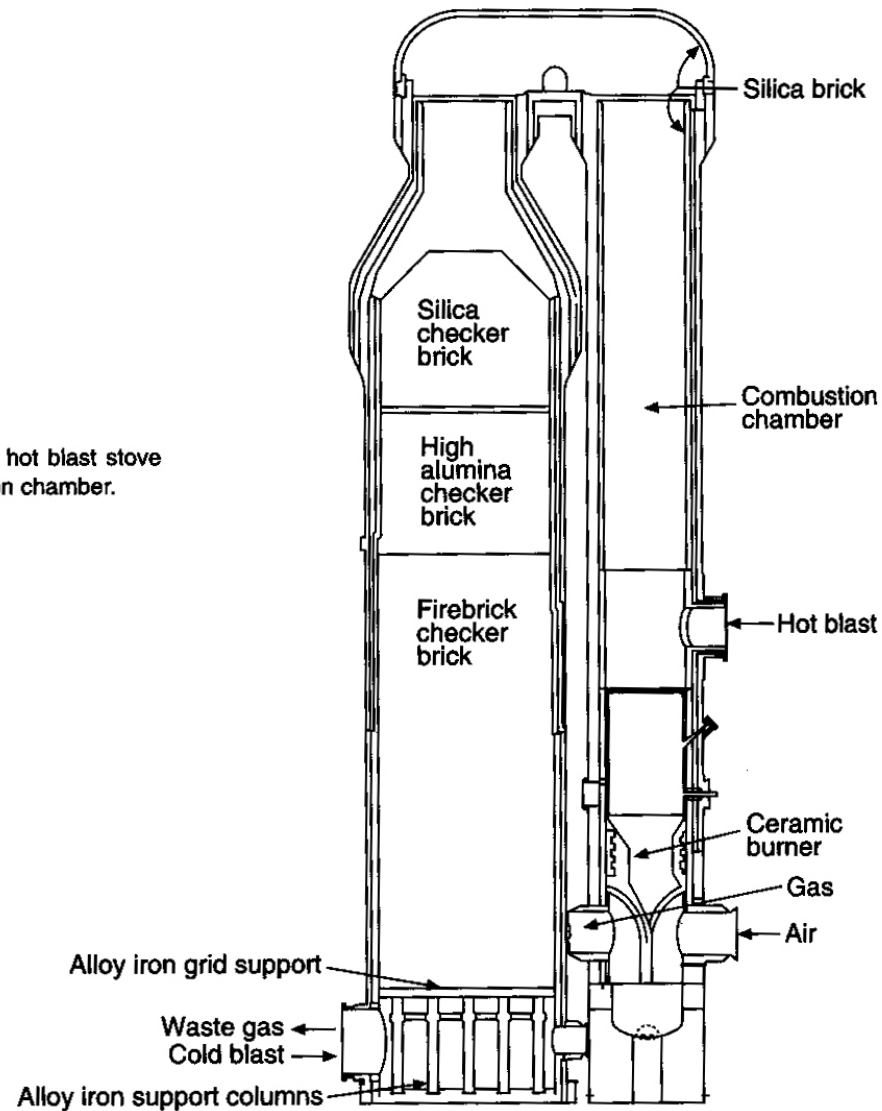

Regeneradores



Alimentação das ventaneiras

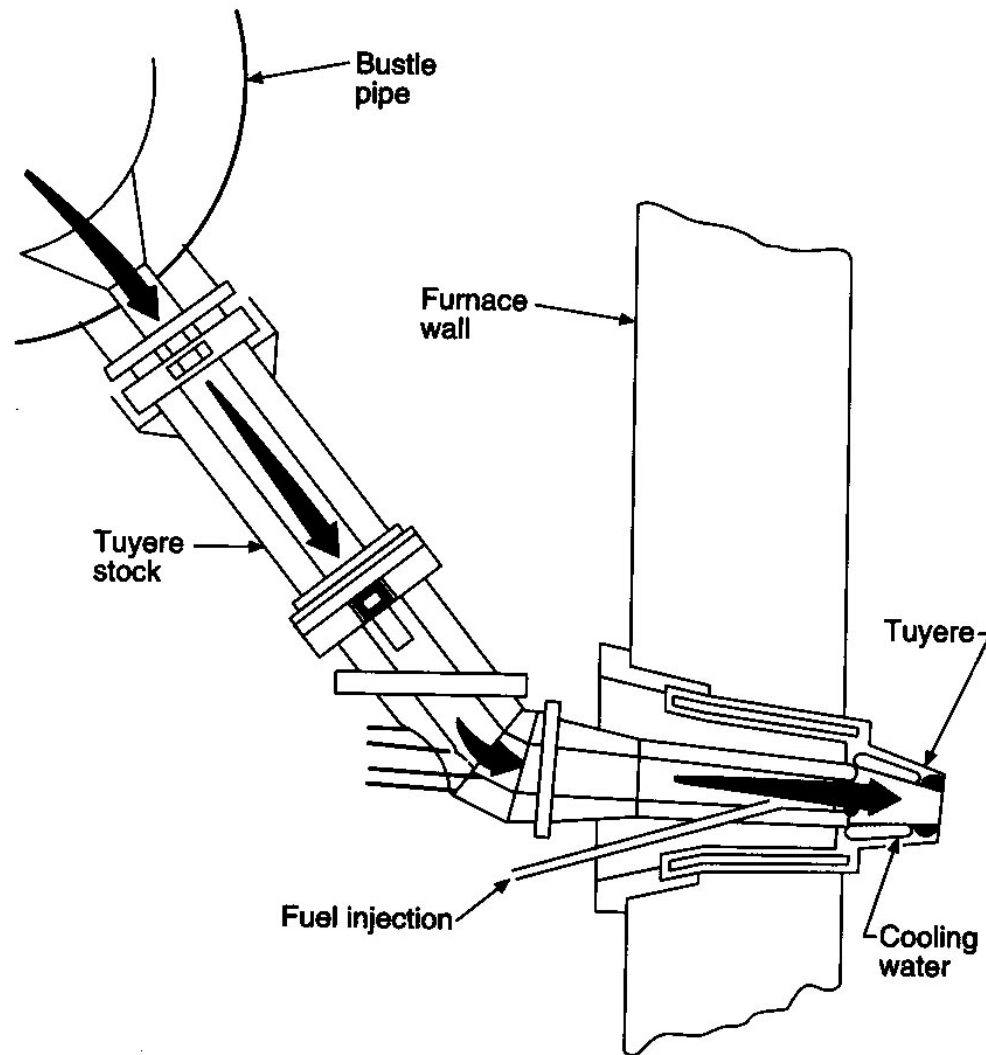

Schematic of a typical tuyere stock arrangement.

Arranjo das ventaneiras no interior do forno e detalhes internos.

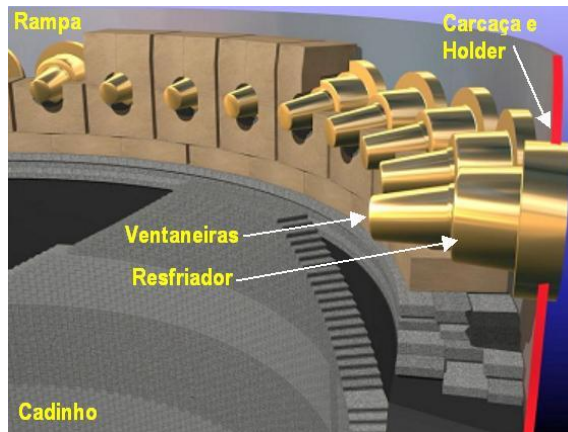

Sopro quente (ventaneira, resfriador, algaraviz, conexões e anel de vento)

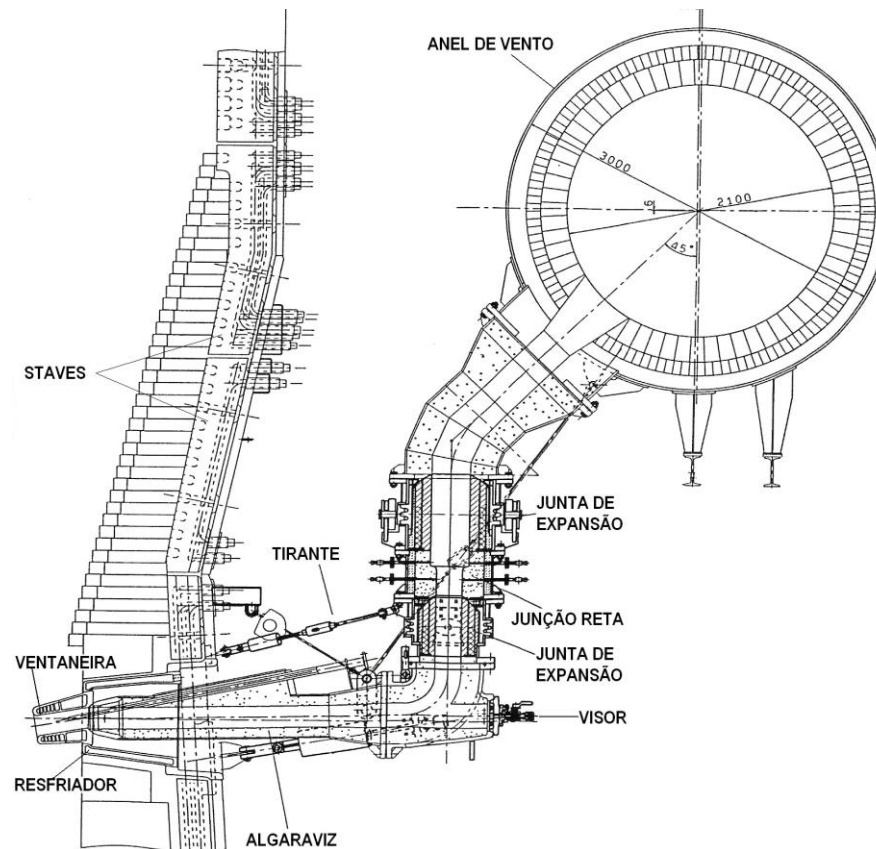

Ventaneira com lança de injeção

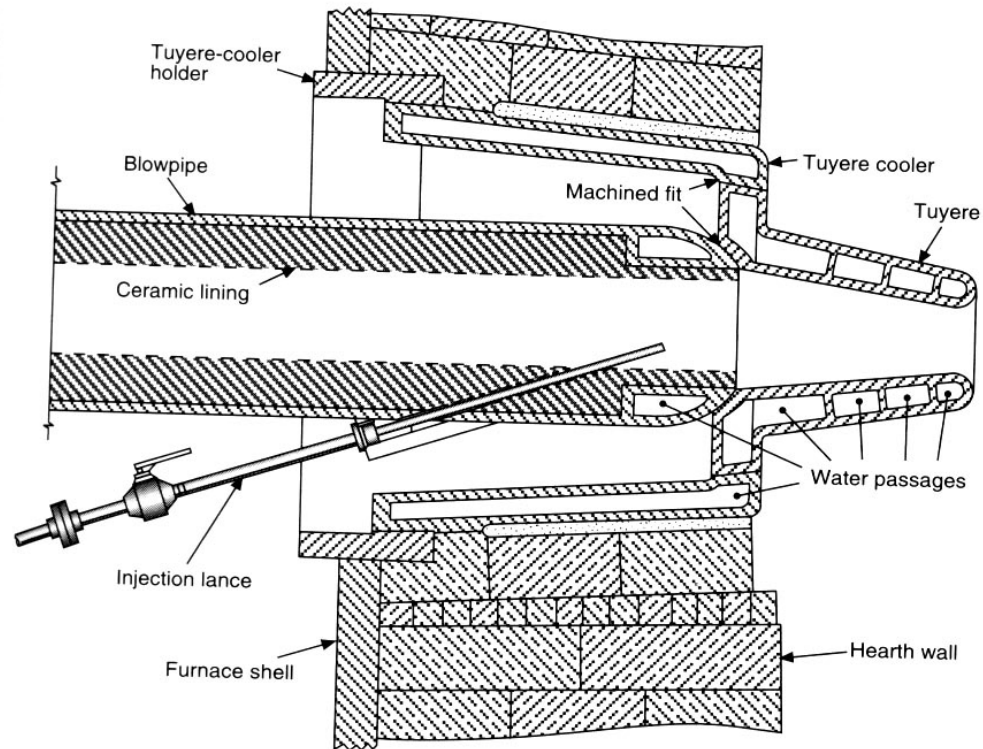

Tuyere and blowpipe assembly, with injection lance.

Injeção de carvão pulverizado através de uma lança inserida pela ventaneira. No detalhe a foto, através do visor da ventaneira, do carvão em combustão na ponta da lança

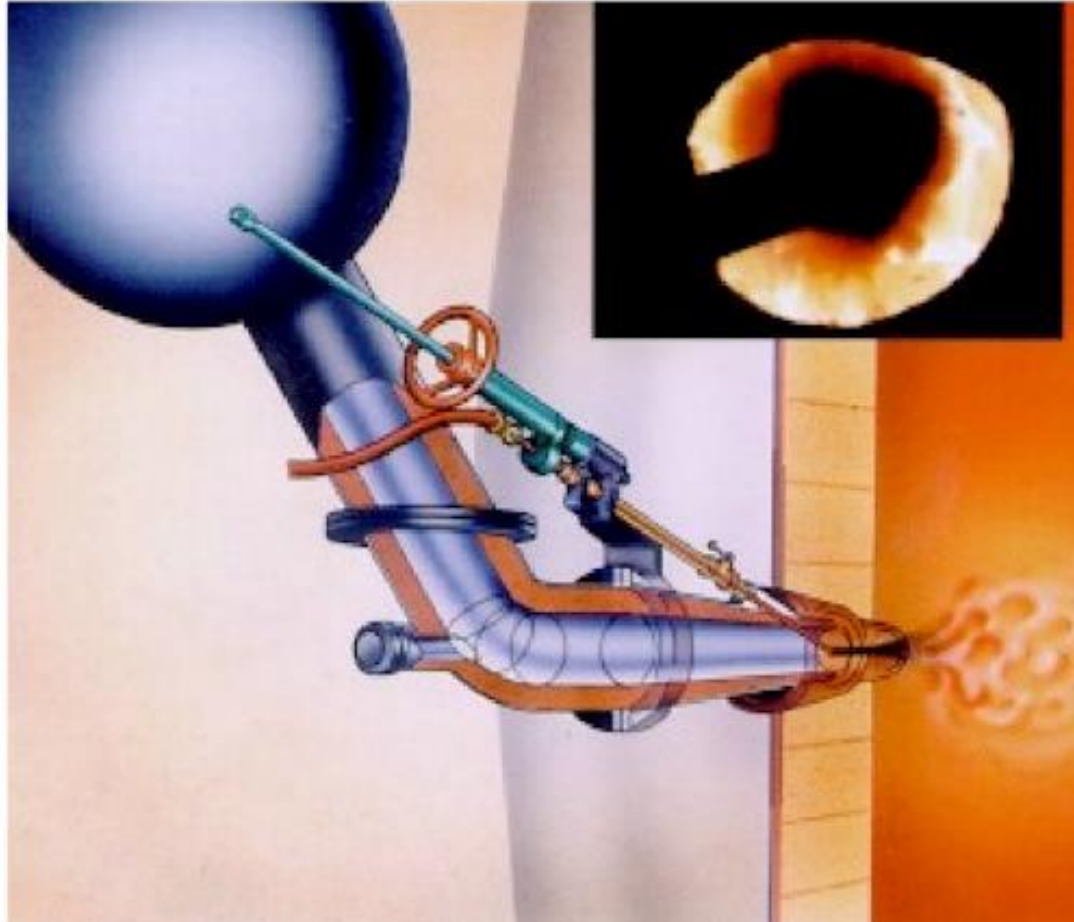

Operação de abertura e fechamento do furo de gusa

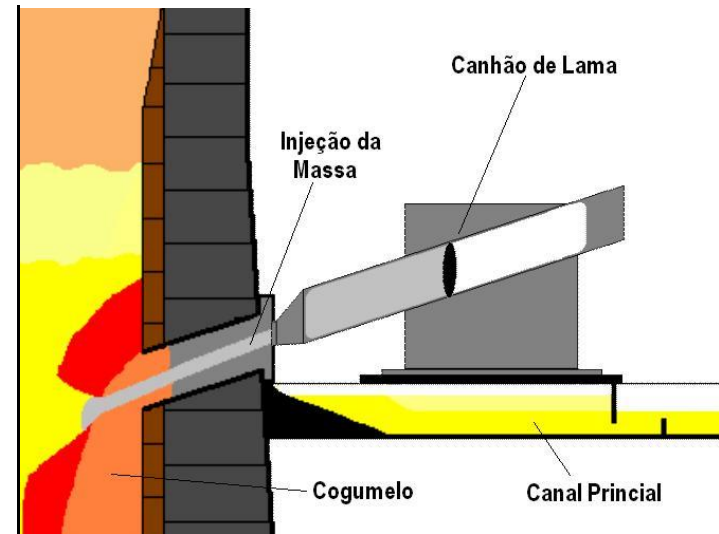
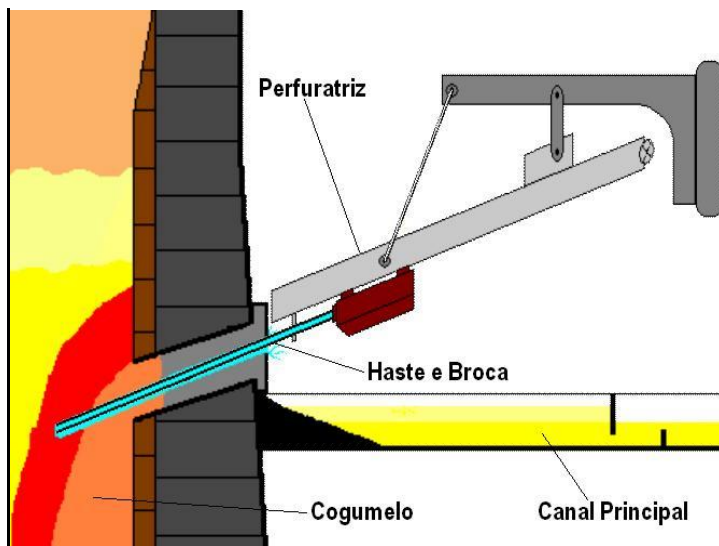

Corrida: Furo de gusa

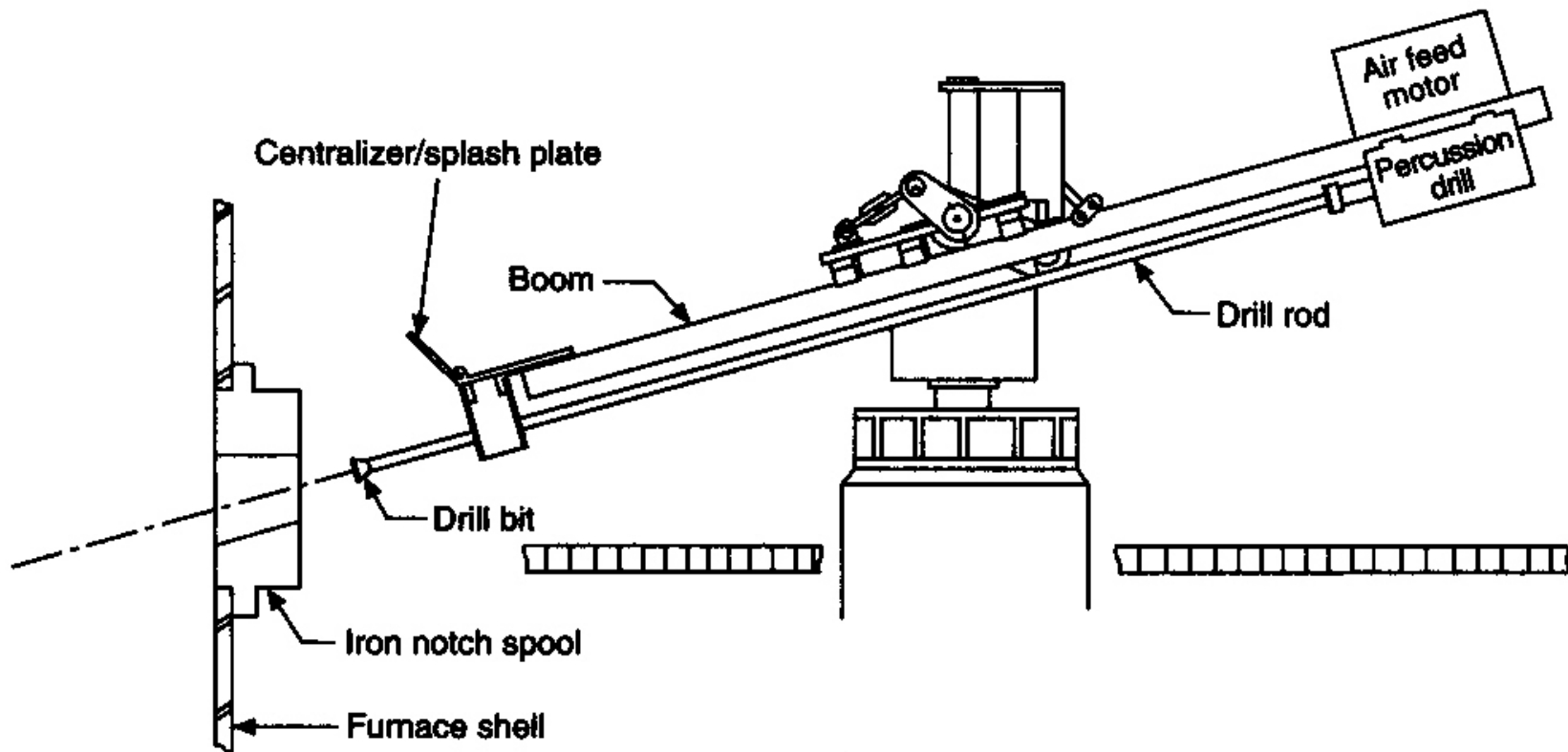

Schematic of a typical taphole drill.

O furo é tapado com massa cerâmica, retirada a cada corrida por broca acionada por motor pneumático, e tapado novamente após a corrida. Pode ter de 1 1/2" a 4".

Sequência de eventos durante uma corrida do alto forno

Início de Corrida



NO INÍCIO DA CORRIDA O NÍVEL DO GUSA NORMALMENTE ESTÁ ACIMA DO NÍVEL DO FURO. CONSEQUENTEMENTE, O GUSA GERALMENTE É O PRIMEIRO MATERIAL A SAIR.

Início de Escória



QUANDO O NÍVEL DE GUSA ABAIXA ATÉ O NÍVEL DO FURO INICIA-SE A SAÍDA DA ESCÓRIA. DEVIDO A SUA ALTA VISCOSIDADE A SUPERFÍCIE DA ESCÓRIA TENDE A ABAIXAR NA REGIÃO ACIMA DO FURO

Fim de Corrida



QUANDO A SUPERFÍCIE DA ESCÓRIA ATINGE O FURO O GÁS COMEÇA A SAIR. É O FINAL DA CORRIDA. NESTE INSTANTE, DEVIDO À INCLINAÇÃO DA SUPERFÍCIE, PARTE AINDA FICA DENTRO DO FORNO

Casa de Corrida

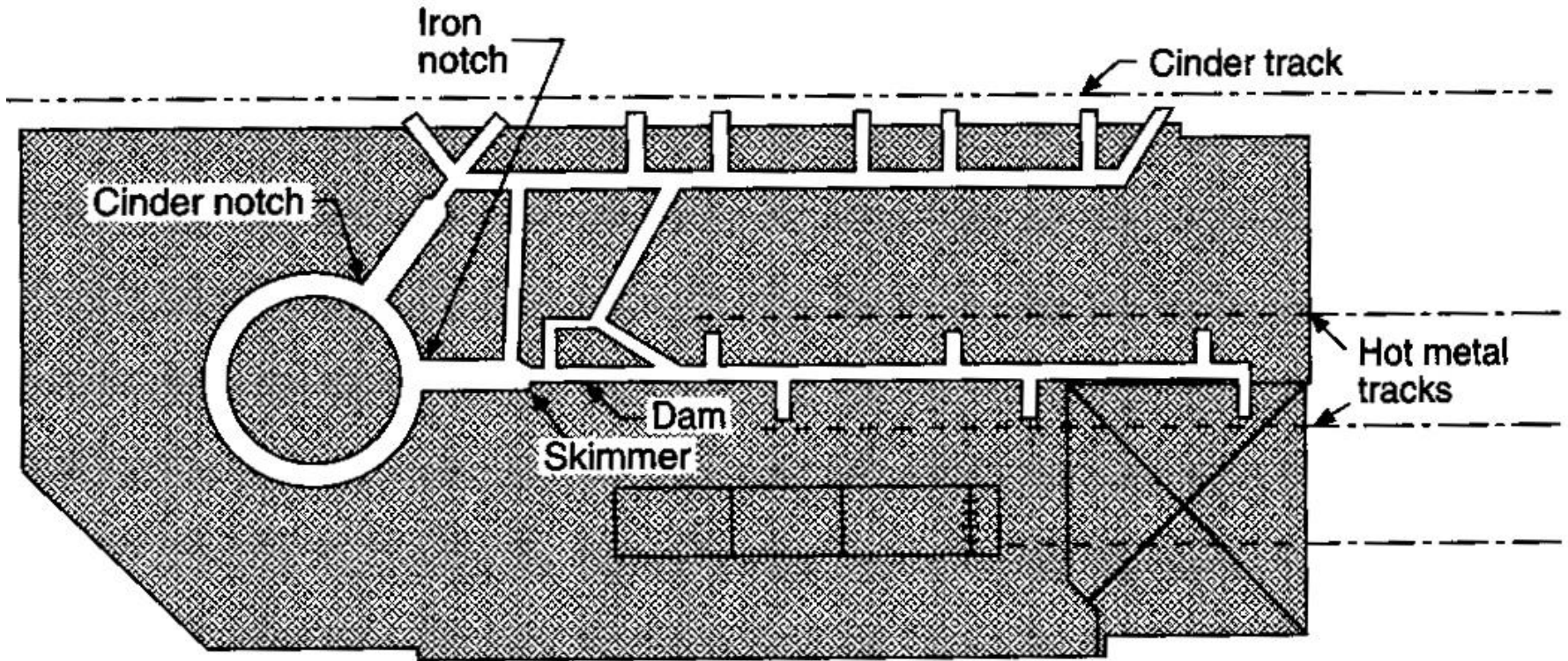

Layout of a single taphole casthouse.

Casa de Corrida

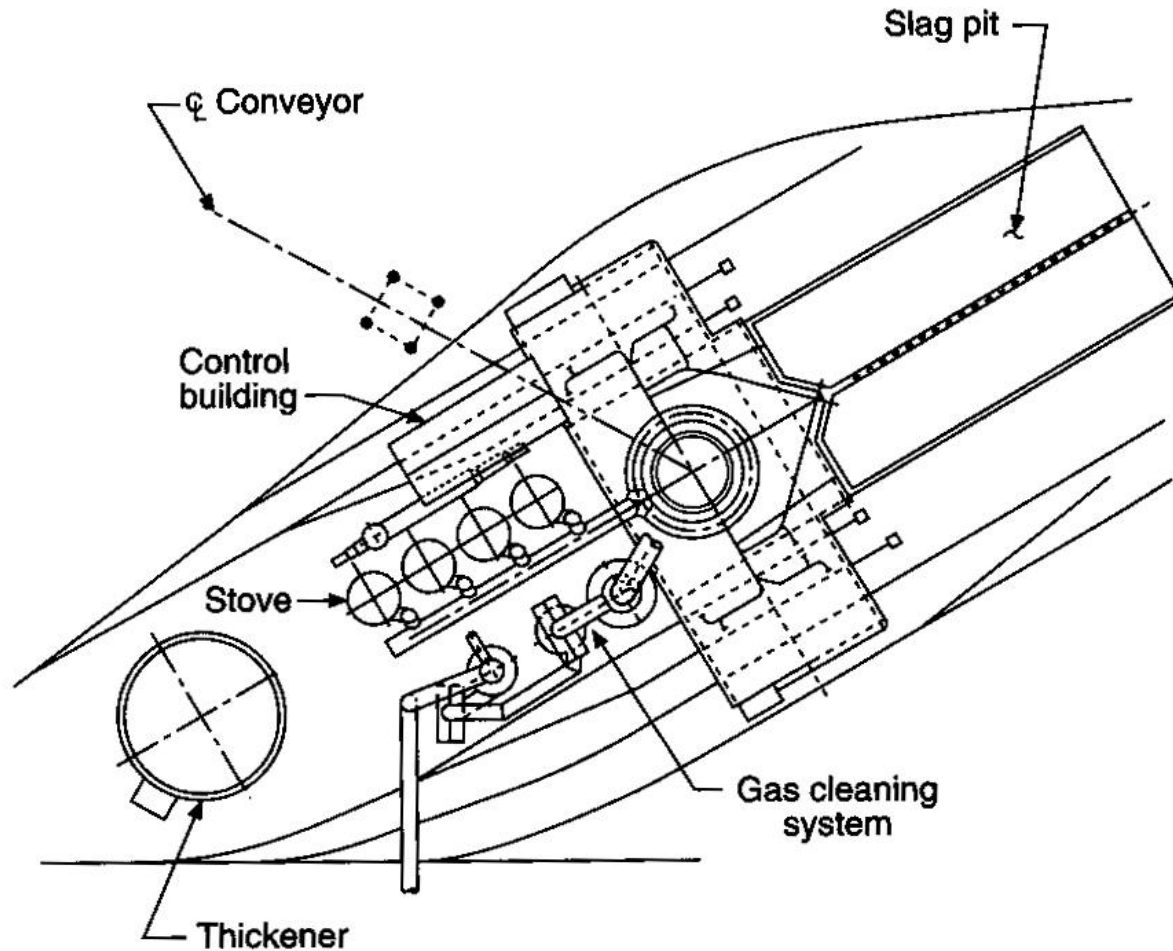

Layout of a casthouse arrangement with two tapholes.

Drenagem do gusa para os carros torpedo

O canhão de lama (1) e a perfuratriz (2) são os equipamentos utilizados para fechar e abrir o furo de gusa. O gusa e a escória, após deixarem o furo na forma de um jato de material líquido, são separados por diferença de densidade no canal principal (3). A escória é direcionada para um sistema de granulação através do canal de escória. O gusa após passar também pelo canal secundário (4), é direcionado para carros torpedos posicionados no piso inferior da casa de corrida, por meio da bica basculante (6), cuja função é permitir a troca dos carros torpedos, direcionando o fluxo de gusa para o carro ao lado. O enchimento do carro torpedo pode ser monitorado automaticamente através de um medidor de nível (5).







Sistemas de refrigeração por Placas e por “Staves”

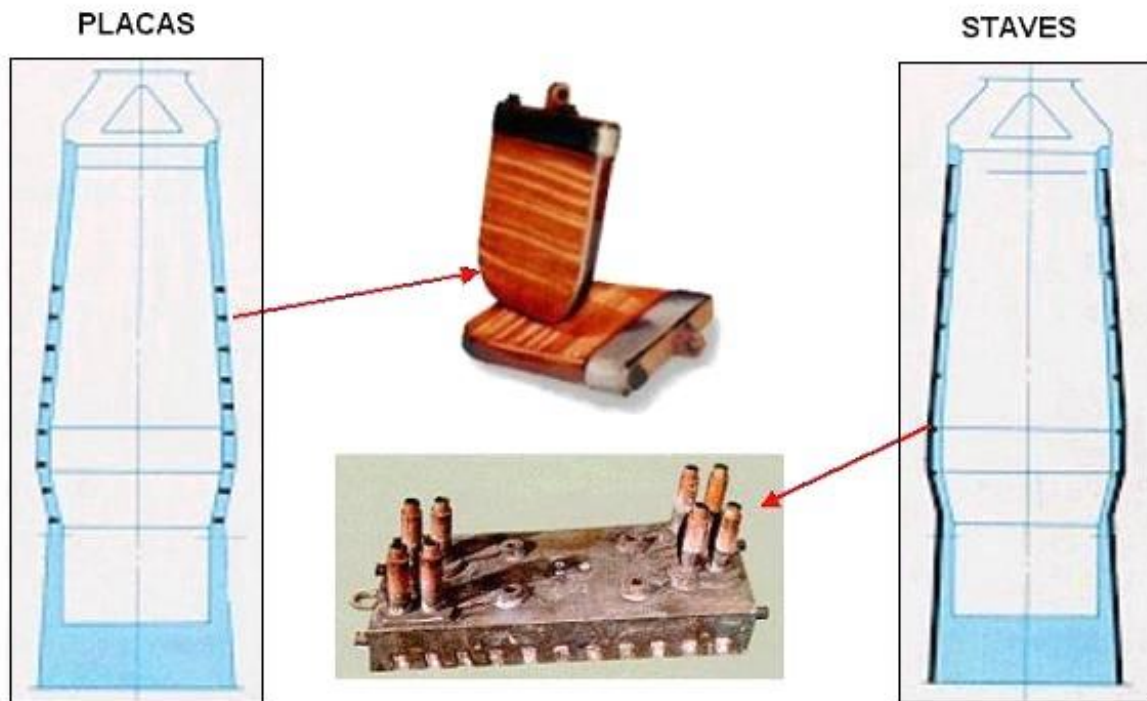



Constituição típica de um stove

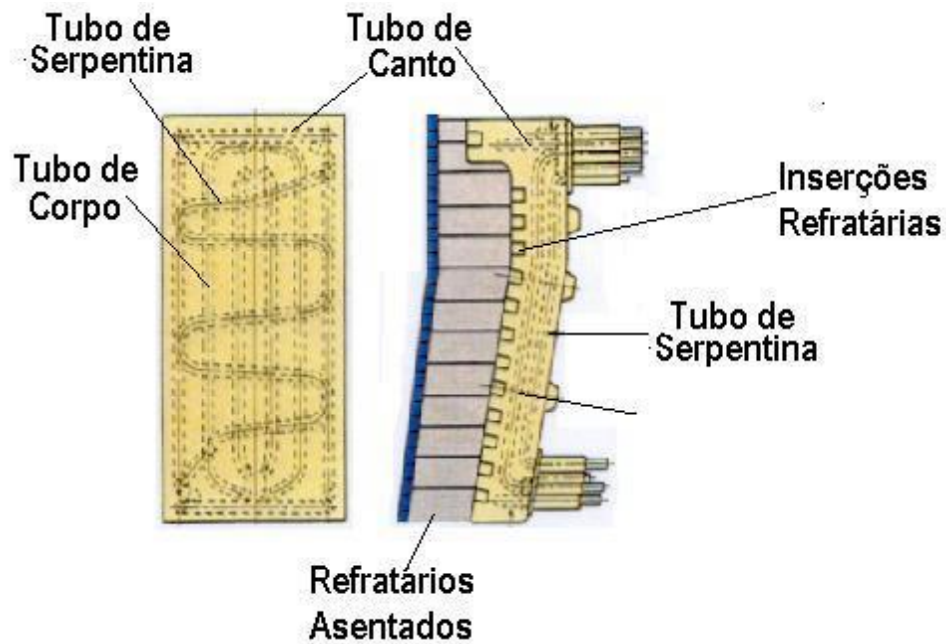

REFRIGERAÇÃO COM STAVES

