



MECATRÔNICA

Simulação Usando Redes de Petri

Software PIPE2



Elementos da Rede de Petri

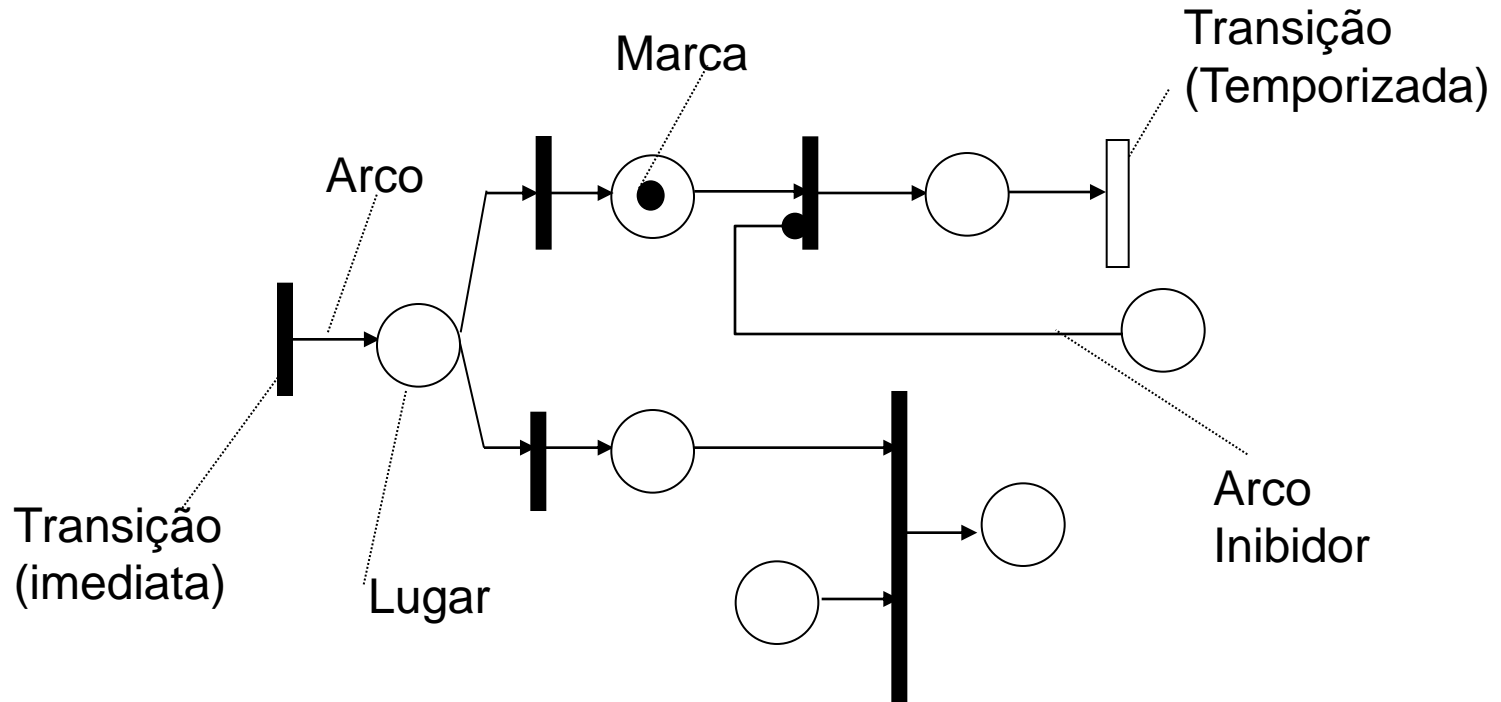

Rede de Petri e as características dos SEDs

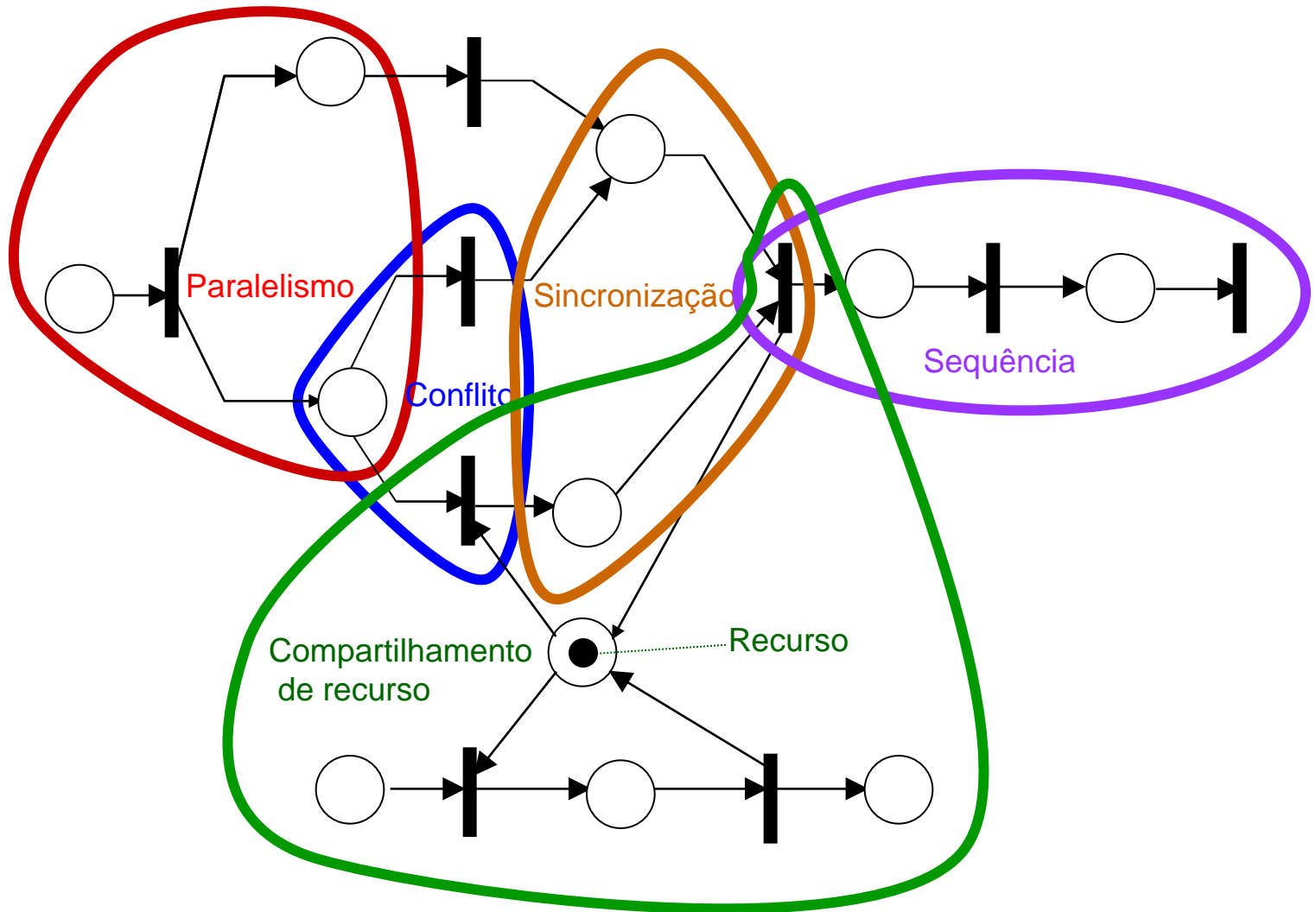

Dinâmica da Rede de Petri

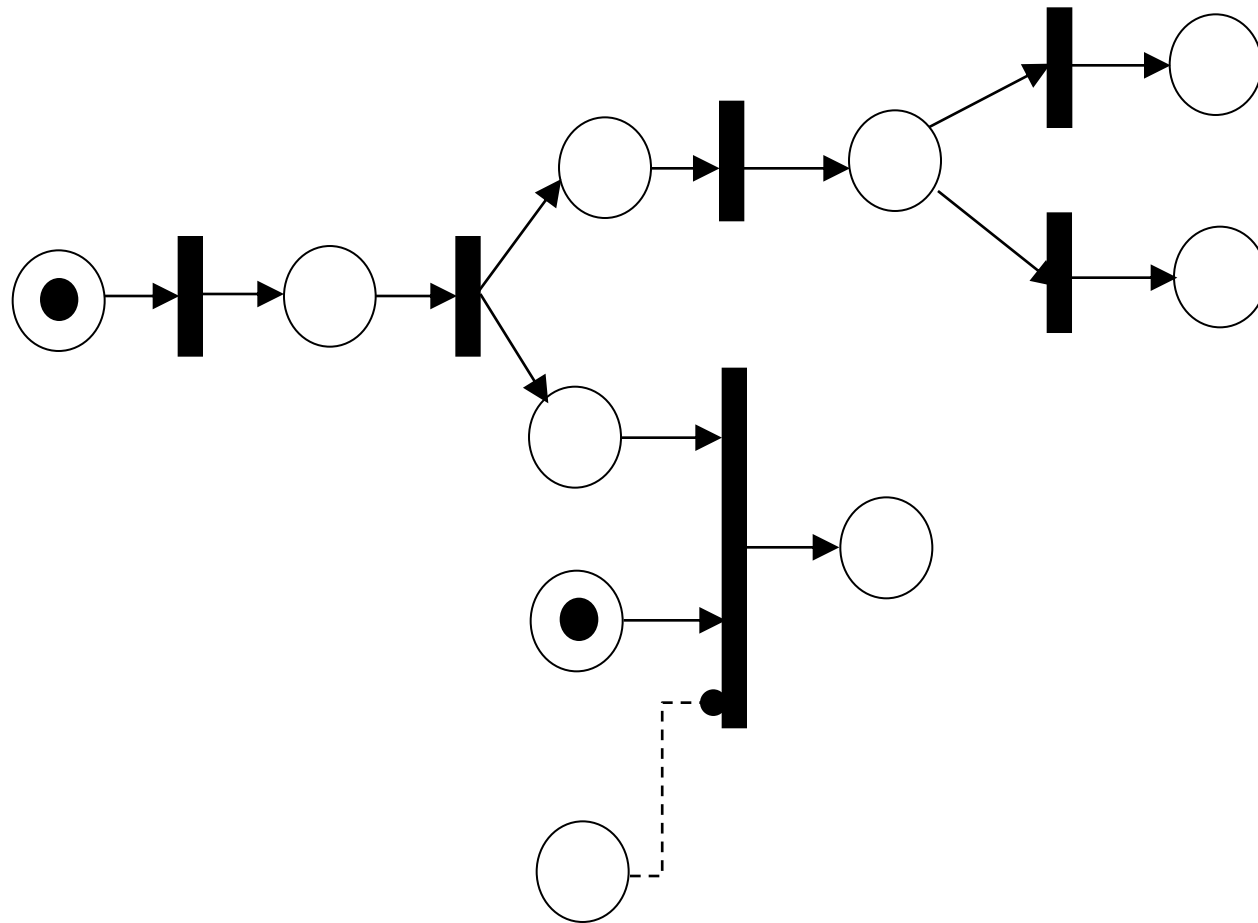

Dinâmica da Rede de Petri

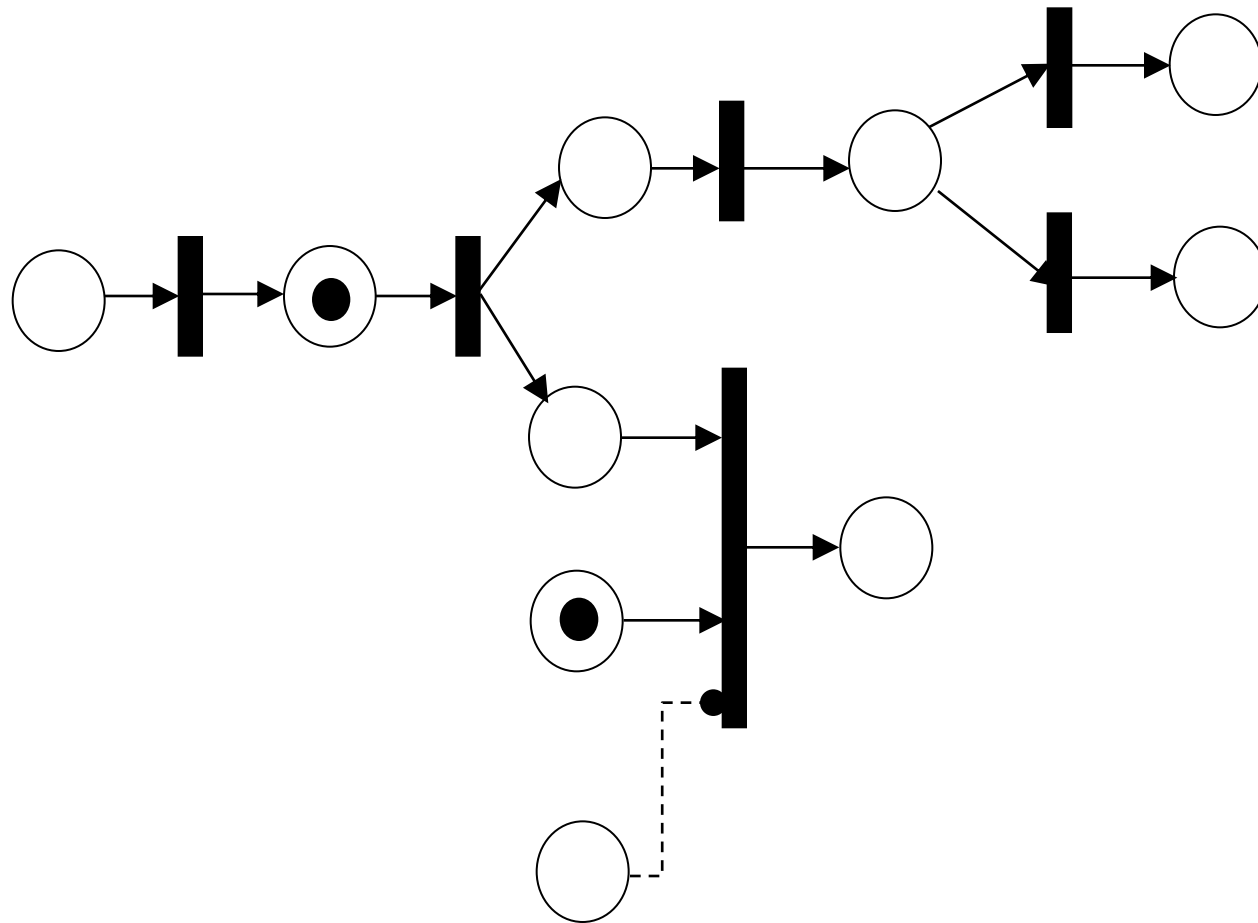

Dinâmica da Rede de Petri

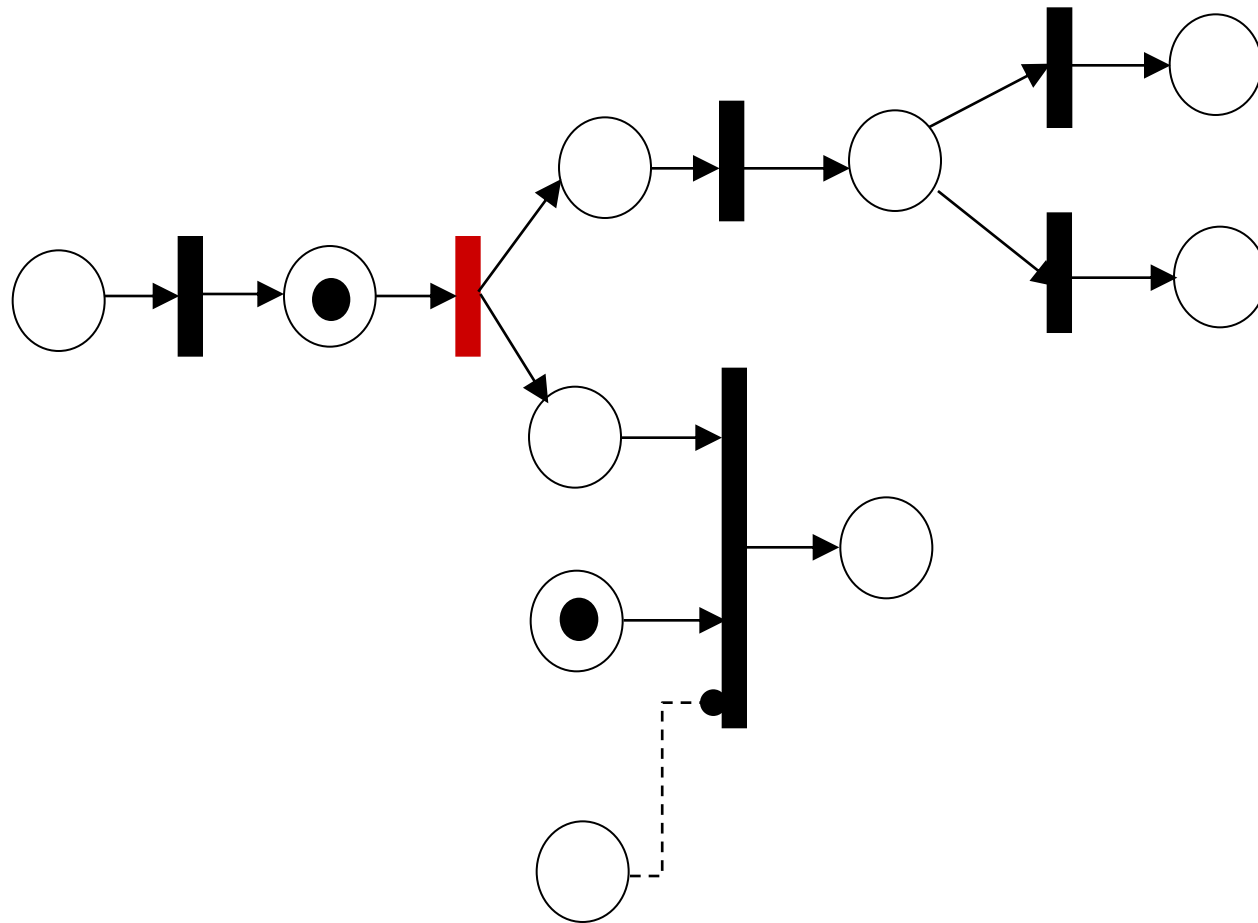

Dinâmica da Rede de Petri

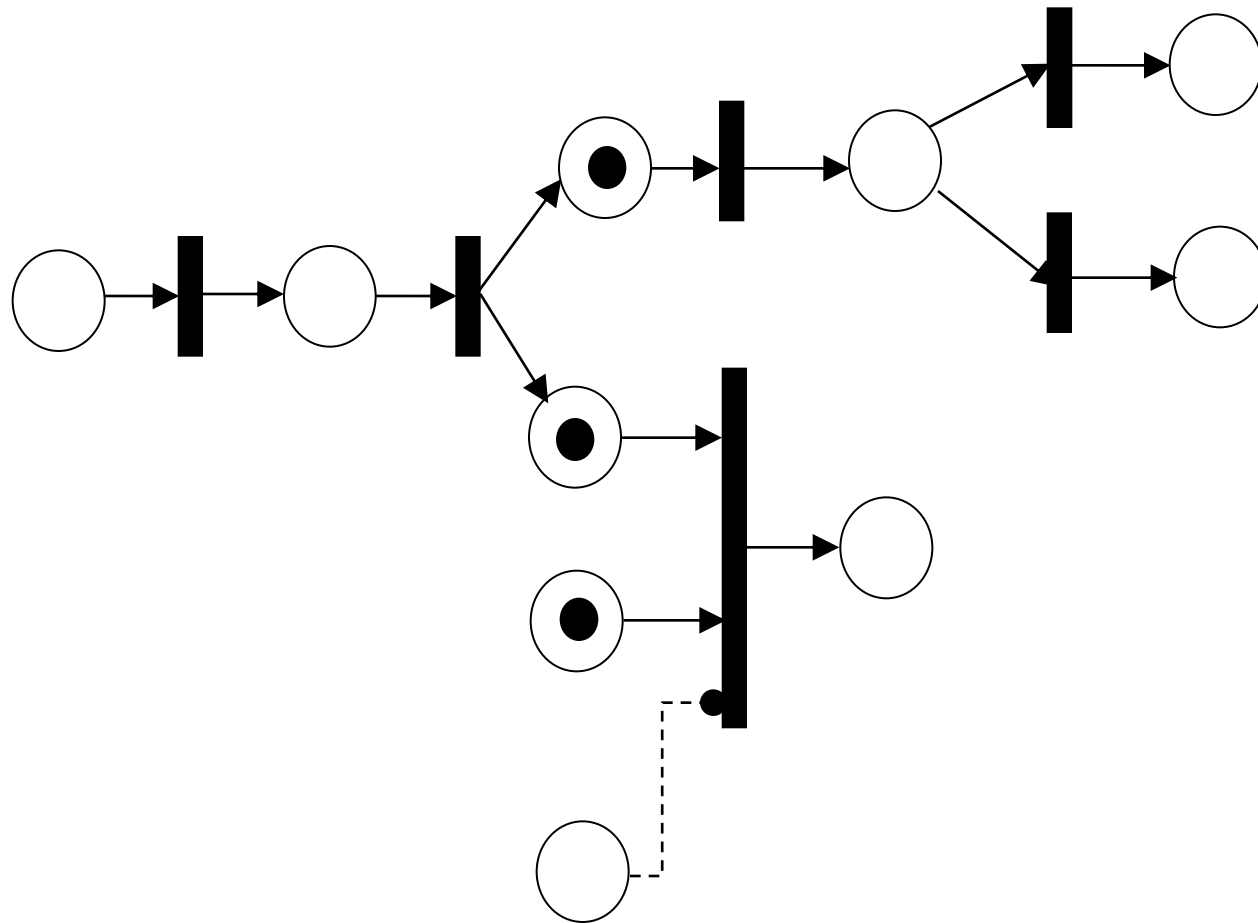

Dinâmica da Rede de Petri

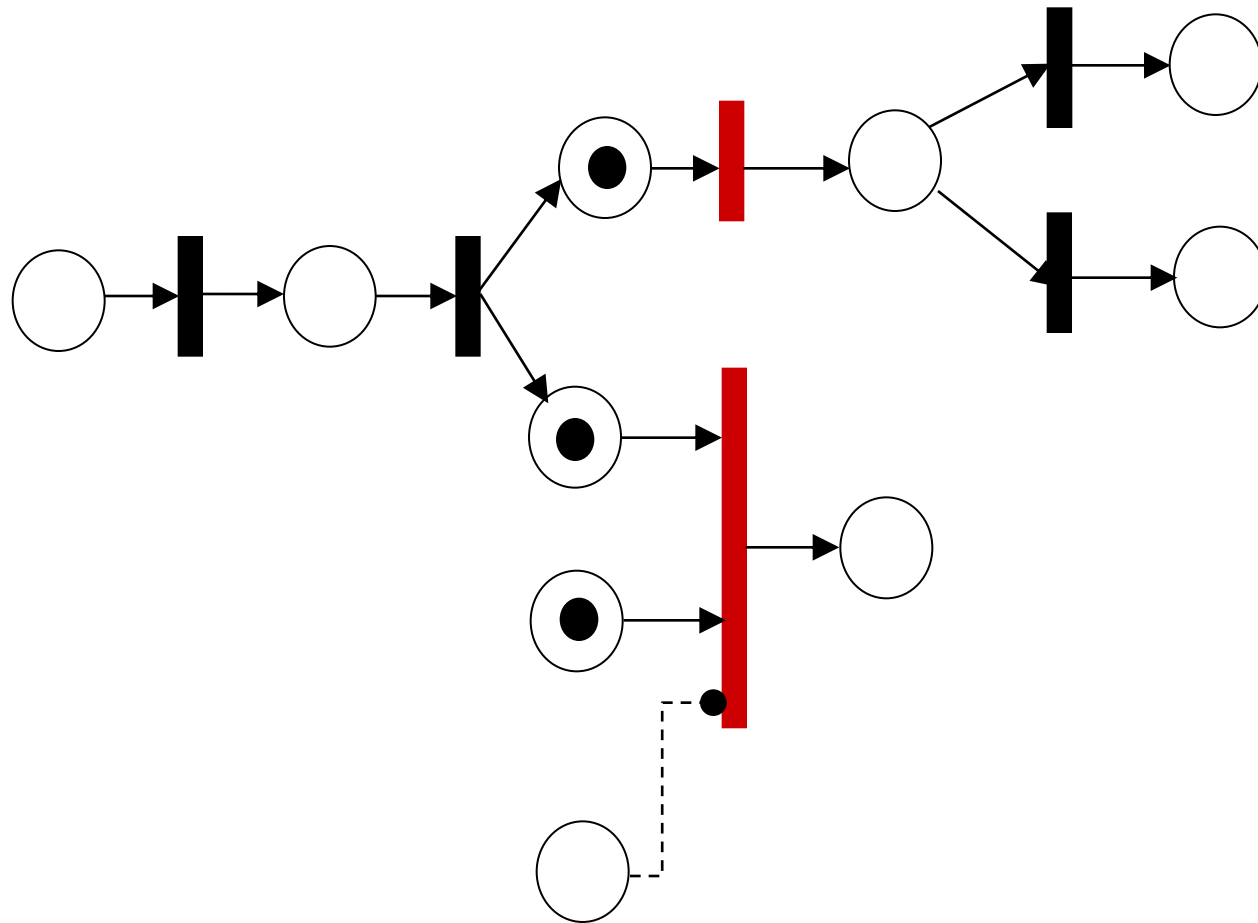

Dinâmica da Rede de Petri

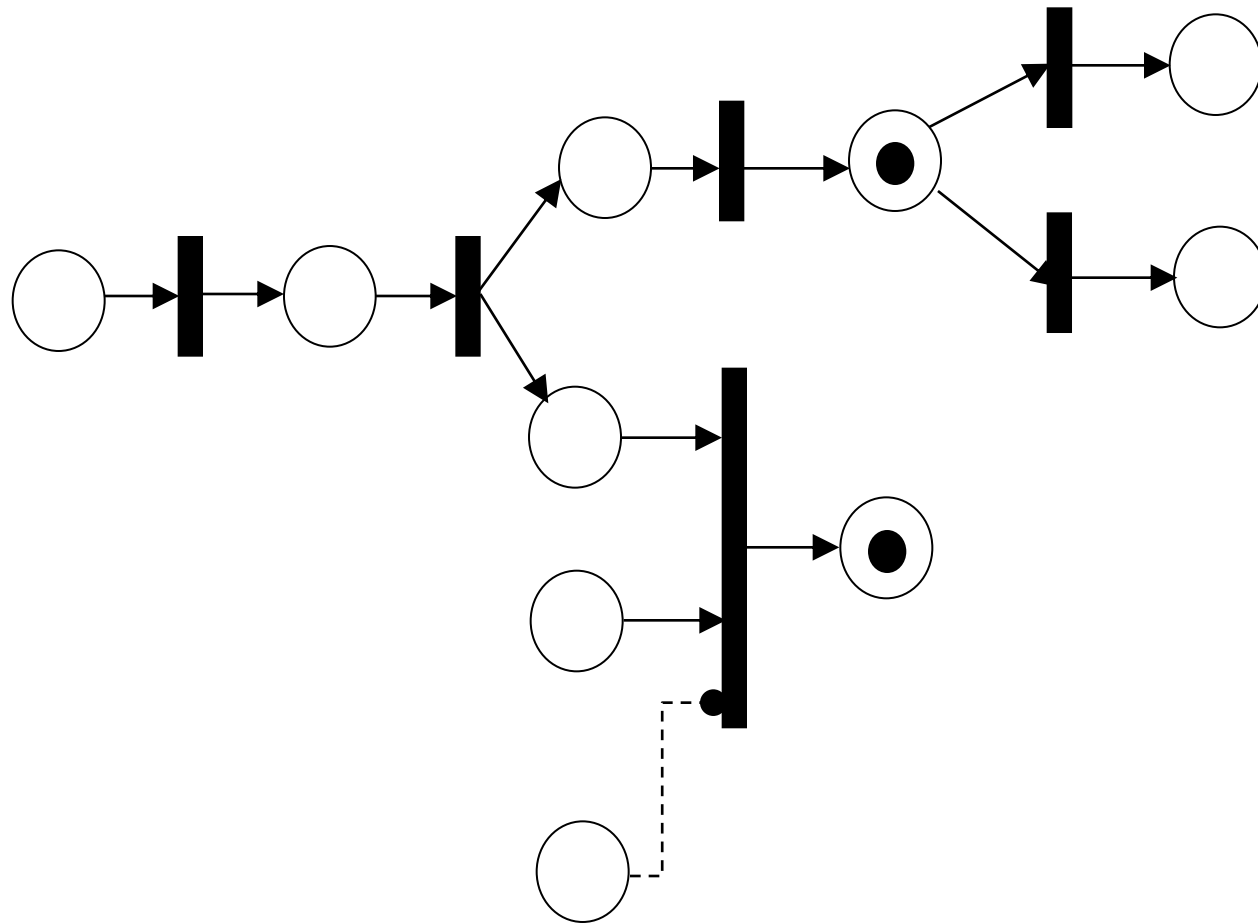

Dinâmica da Rede de Petri

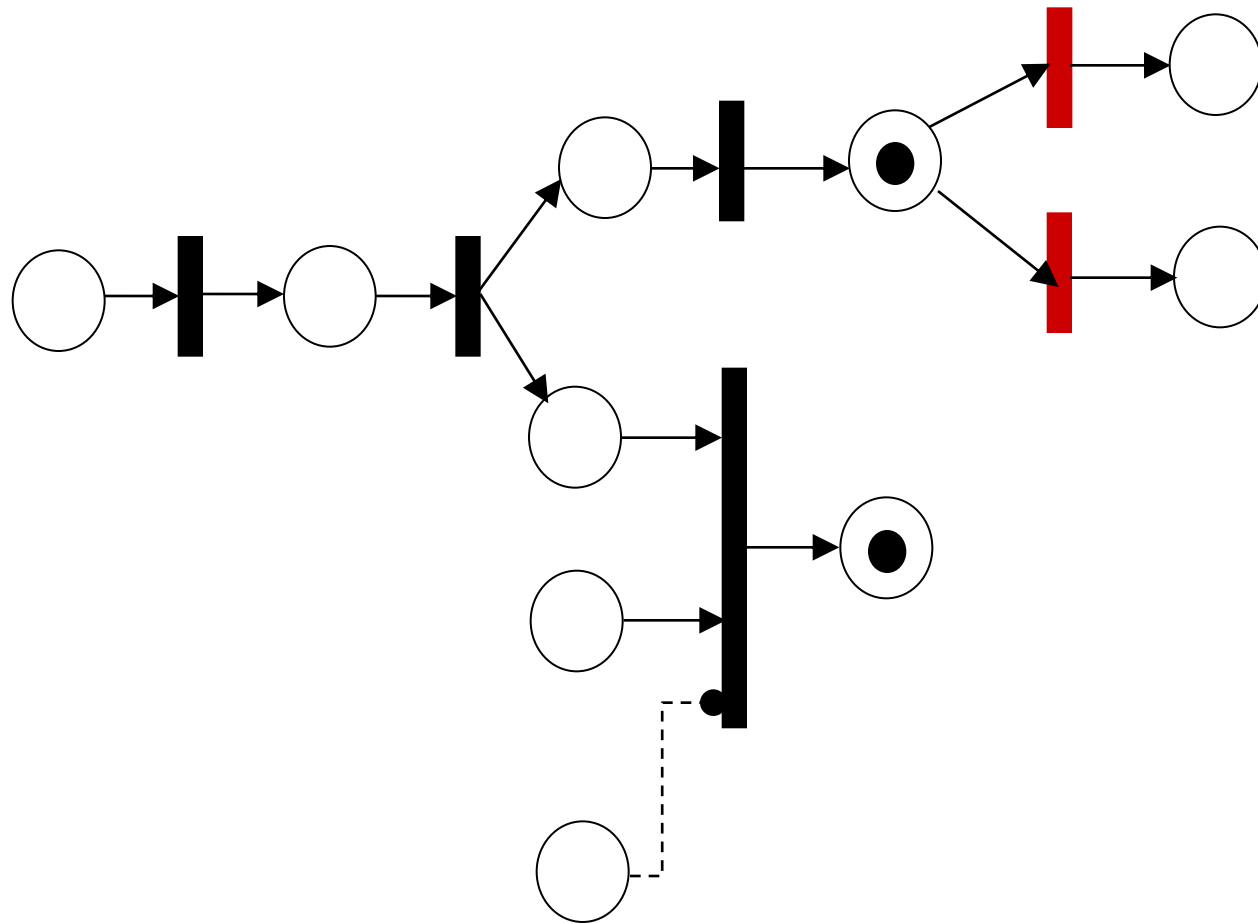

Dinâmica da Rede de Petri

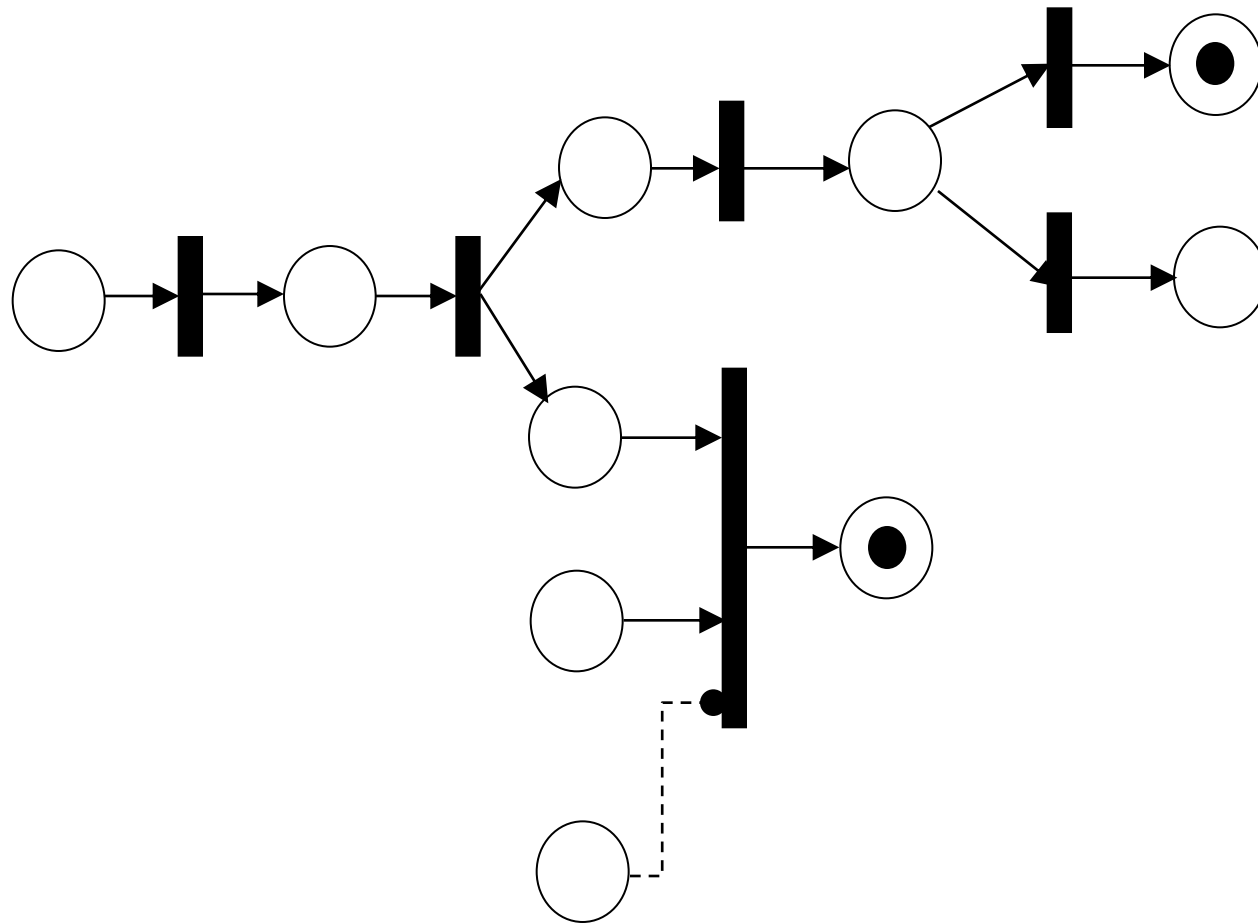

Dinâmica da Rede de Petri Temporizada

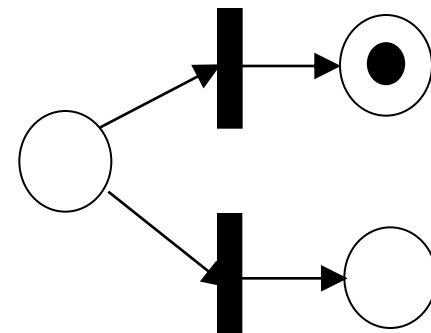
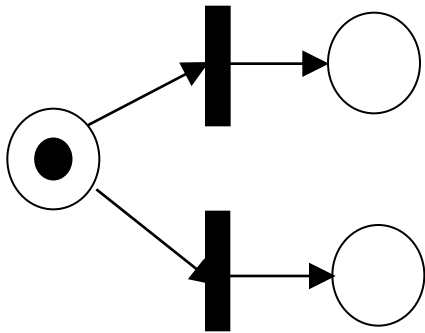

Dinâmica da Rede de Petri Temporizada

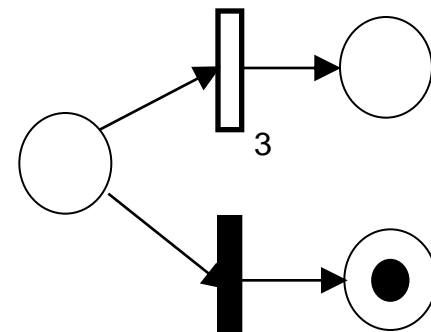
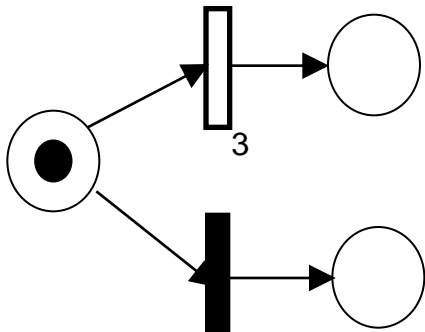

Dinâmica da Rede de Petri Temporizada

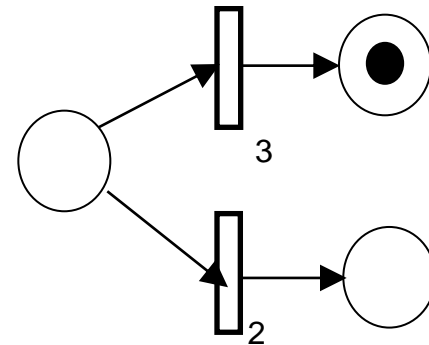
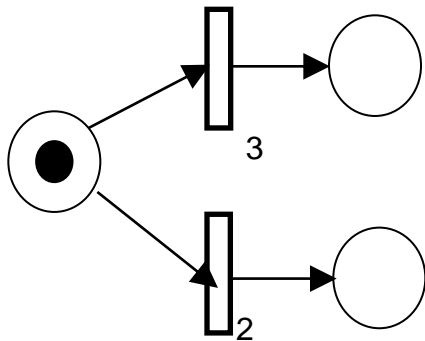

Formalização Matemática

Representação Matricial

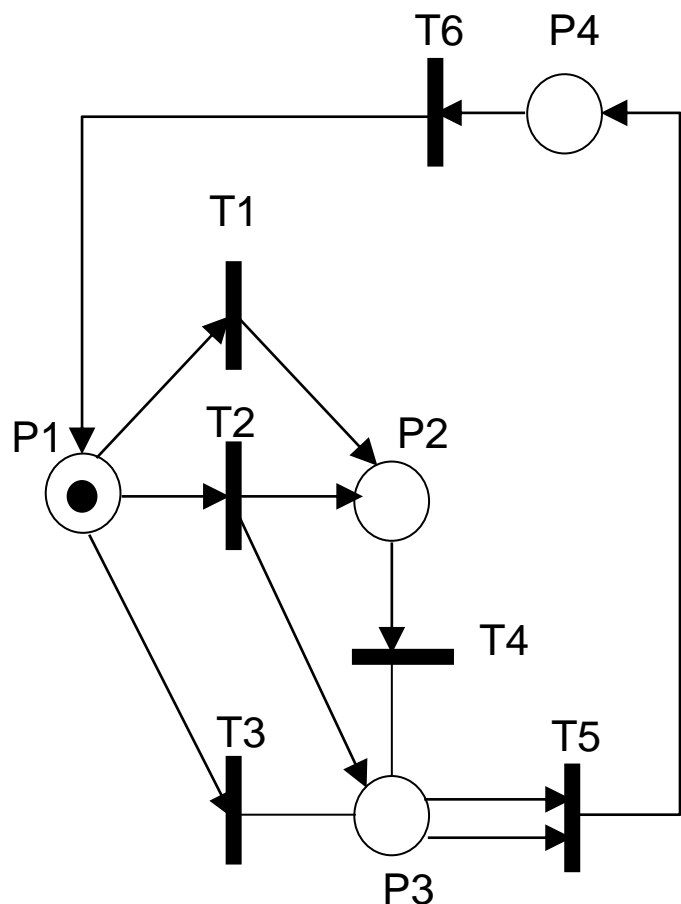

$$M = M_0 + C * s$$

$M_0 = \begin{bmatrix} 1 \\ 0 \\ 0 \\ 0 \end{bmatrix} \begin{matrix} P1 \\ P2 \\ P3 \\ P4 \end{matrix}$ } Lugares
 Marcação inicial

$s = \begin{bmatrix} 1 \\ 0 \\ 0 \\ 0 \\ 0 \\ 0 \end{bmatrix} \begin{matrix} T1 \\ T2 \\ T3 \\ T4 \\ T5 \\ T6 \end{matrix}$ } Trans.
 Vetor de disparo

Transições

	T1	T2	T3	T4	T5	T6	
-1	-1	-1	0	0	0	+1	P1
+1	+1	0	-1	0	0	0	P2
0	+1	+1	+1	-2	0	0	P3
0	0	0	0	0	+1	-1	P4

$C = \begin{bmatrix} -1 & -1 & -1 & 0 & 0 & +1 \\ +1 & +1 & 0 & -1 & 0 & 0 \\ 0 & +1 & +1 & +1 & -2 & 0 \\ 0 & 0 & 0 & 0 & +1 & -1 \end{bmatrix} \begin{matrix} P1 \\ P2 \\ P3 \\ P4 \end{matrix}$ } Lugares

Matriz de Incidência

Aplicação: Sistema Máquina-Ferramenta e Robô

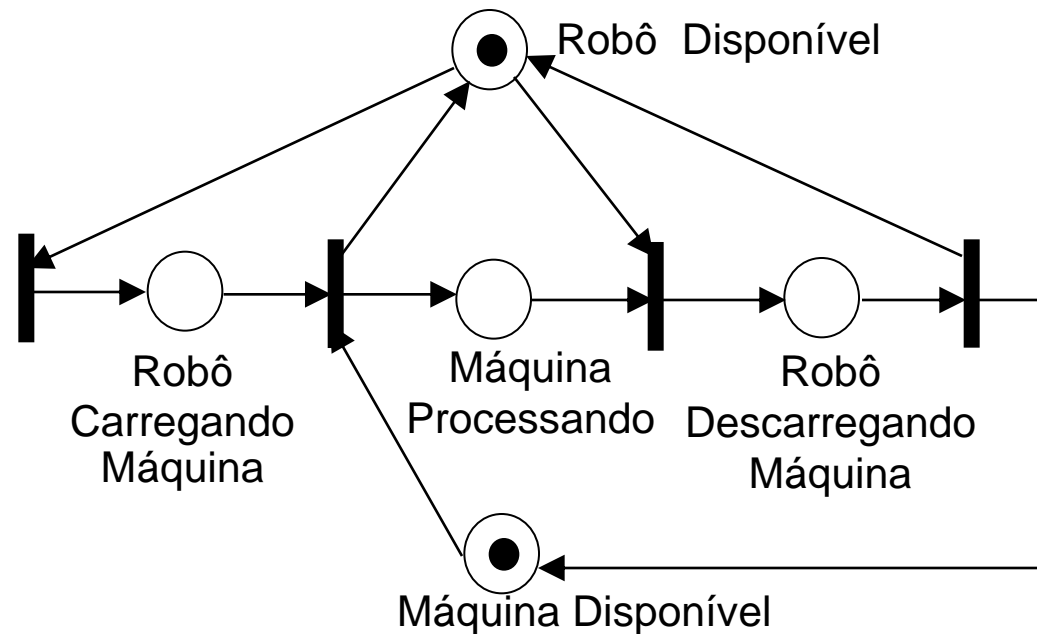
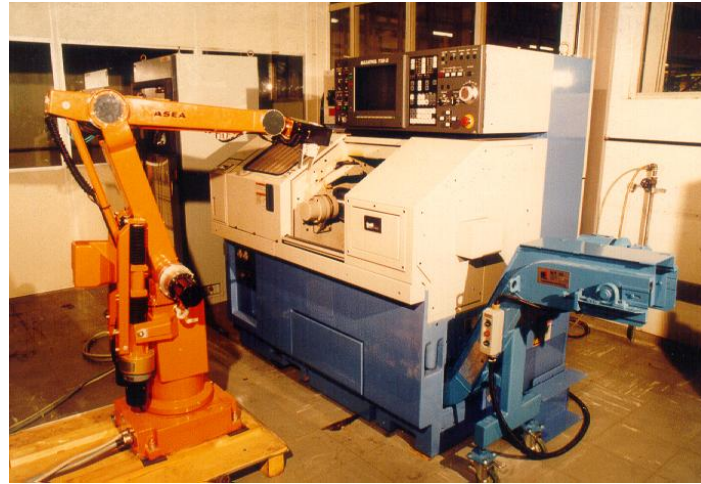

Aplicação: Sistema Máquina-Ferramenta e Robô

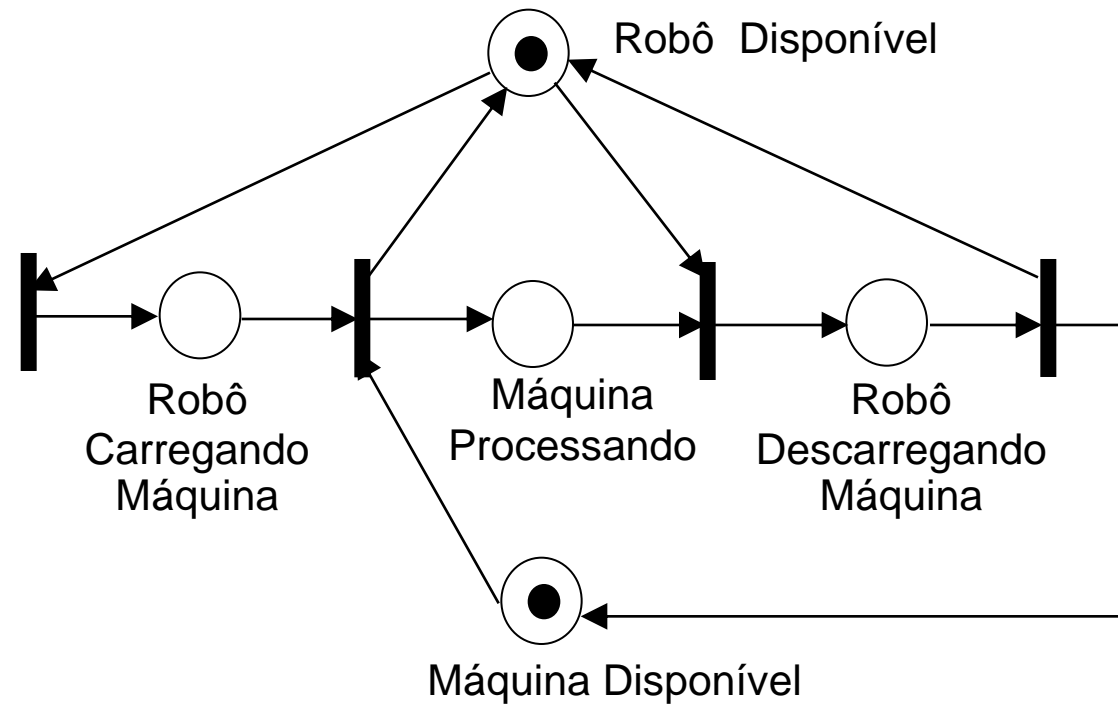

Aplicação: Sistema Máquina-Ferramenta e Robô

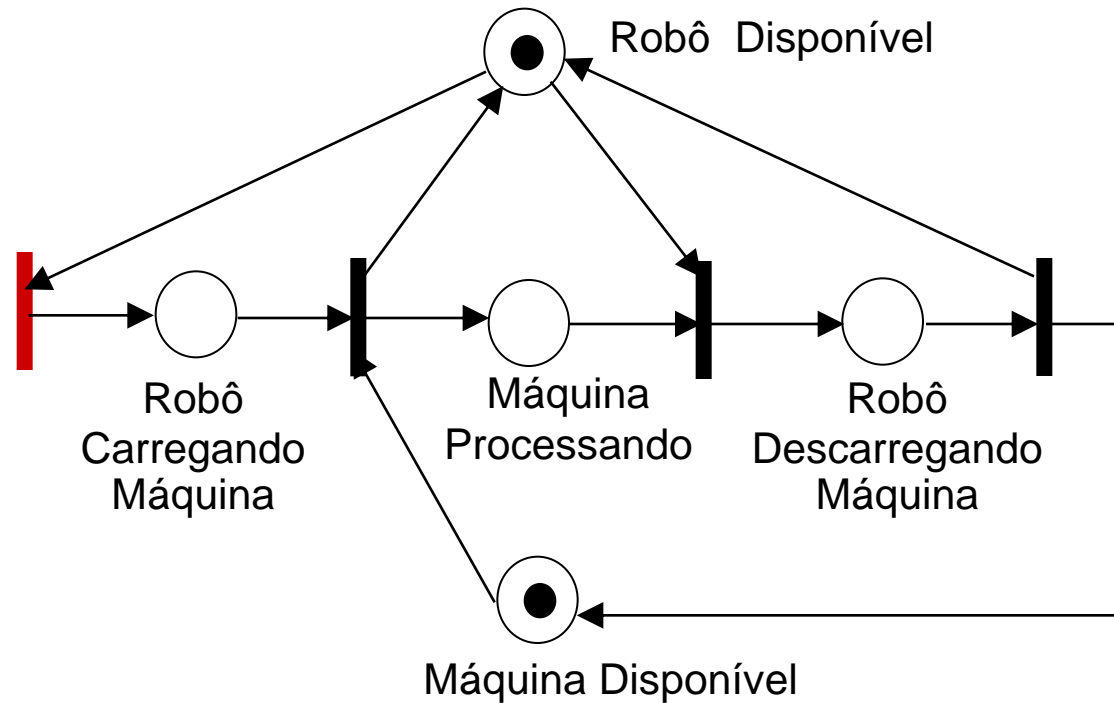

Aplicação: Sistema Máquina-Ferramenta e Robô

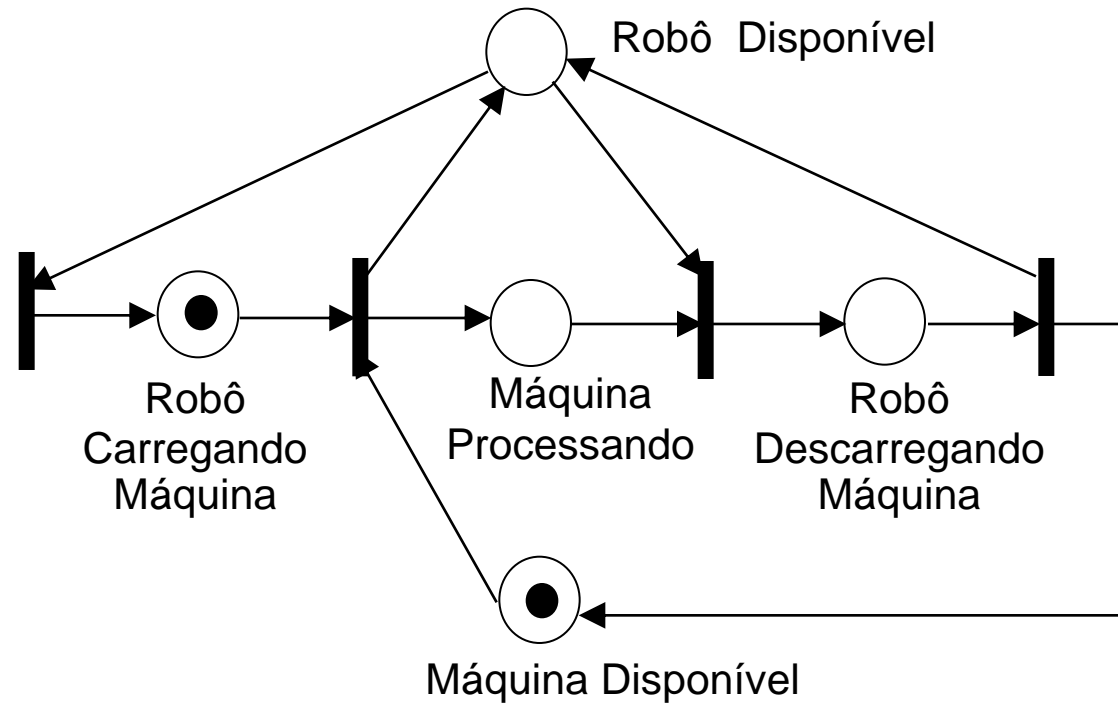

Aplicação: Sistema Máquina-Ferramenta e Robô

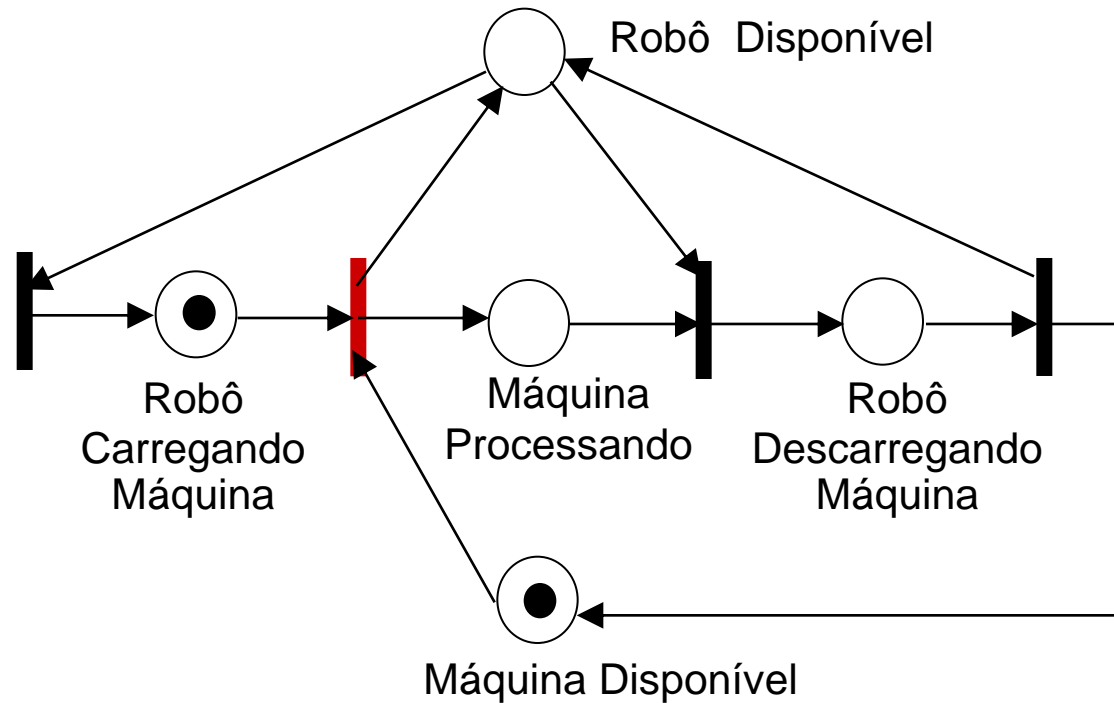

Aplicação: Sistema Máquina-Ferramenta e Robô

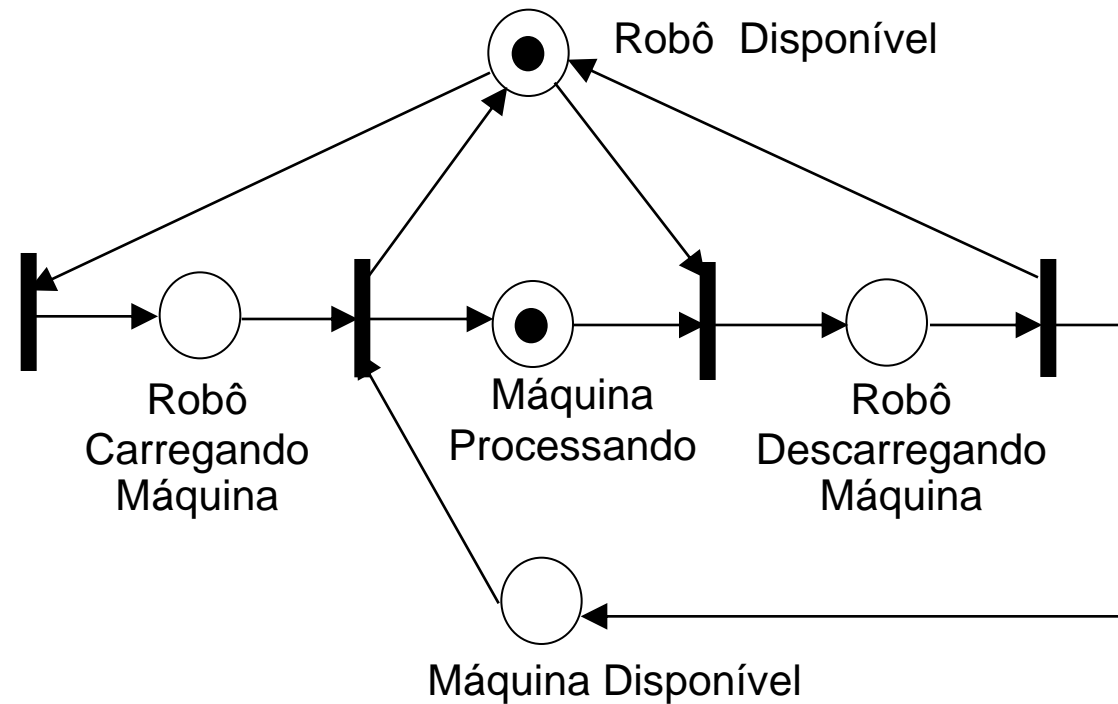

Aplicação: Sistema Máquina-Ferramenta e Robô

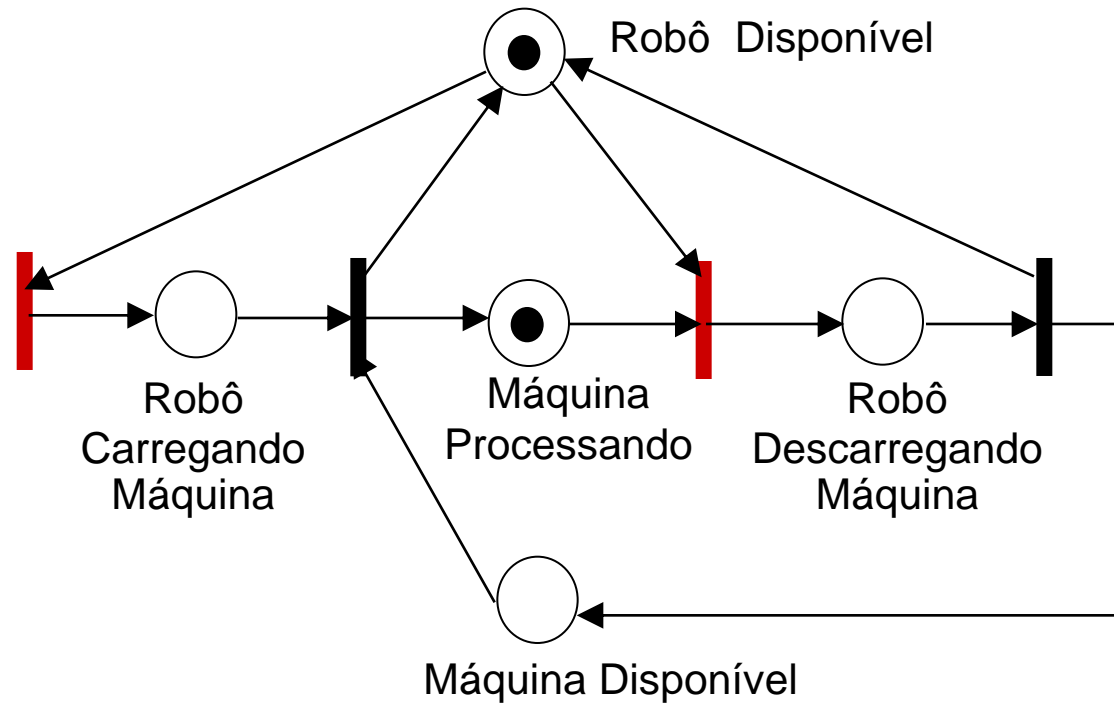

Aplicação: Sistema Máquina-Ferramenta e Robô

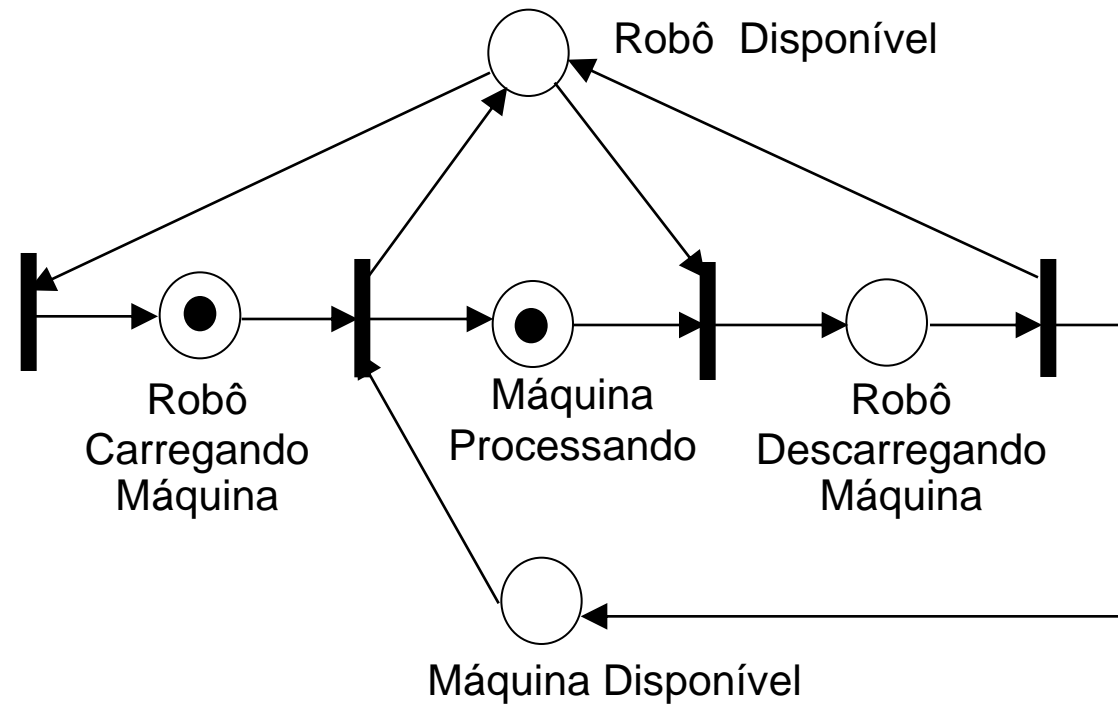

Aplicação: Sistema Máquina-Ferramenta e Robô

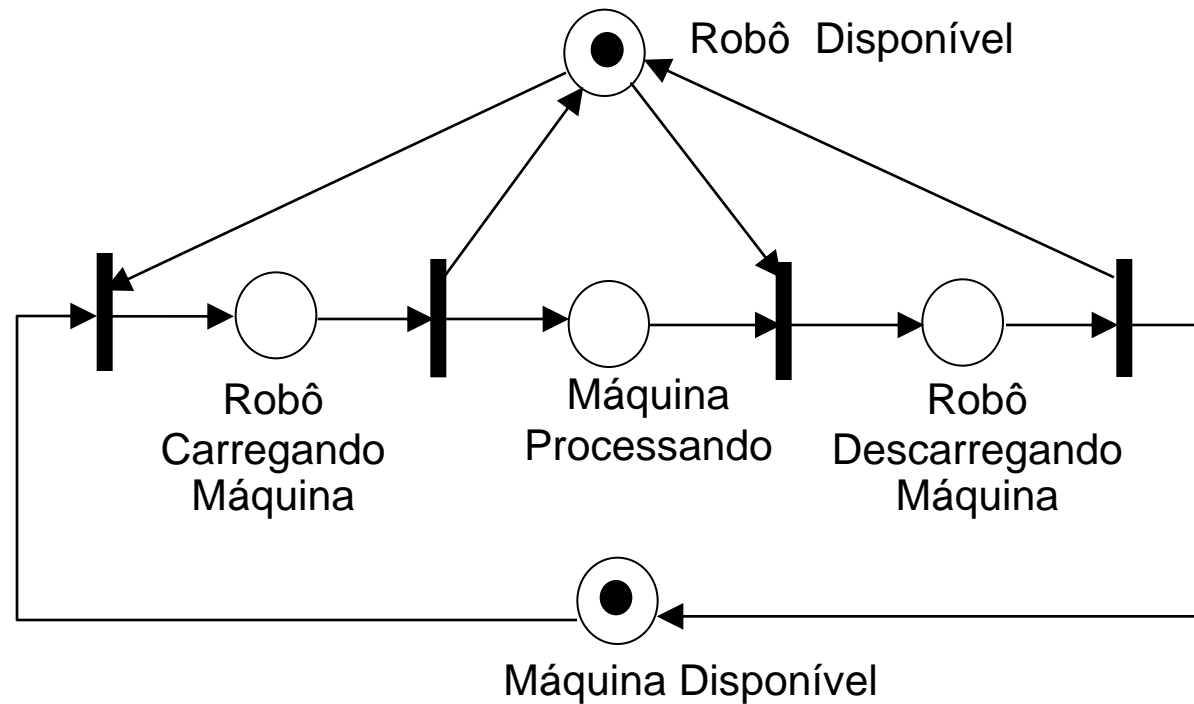

PIPE2: Software de Simulação de Redes de Petri

Barra principal

Barra de edição

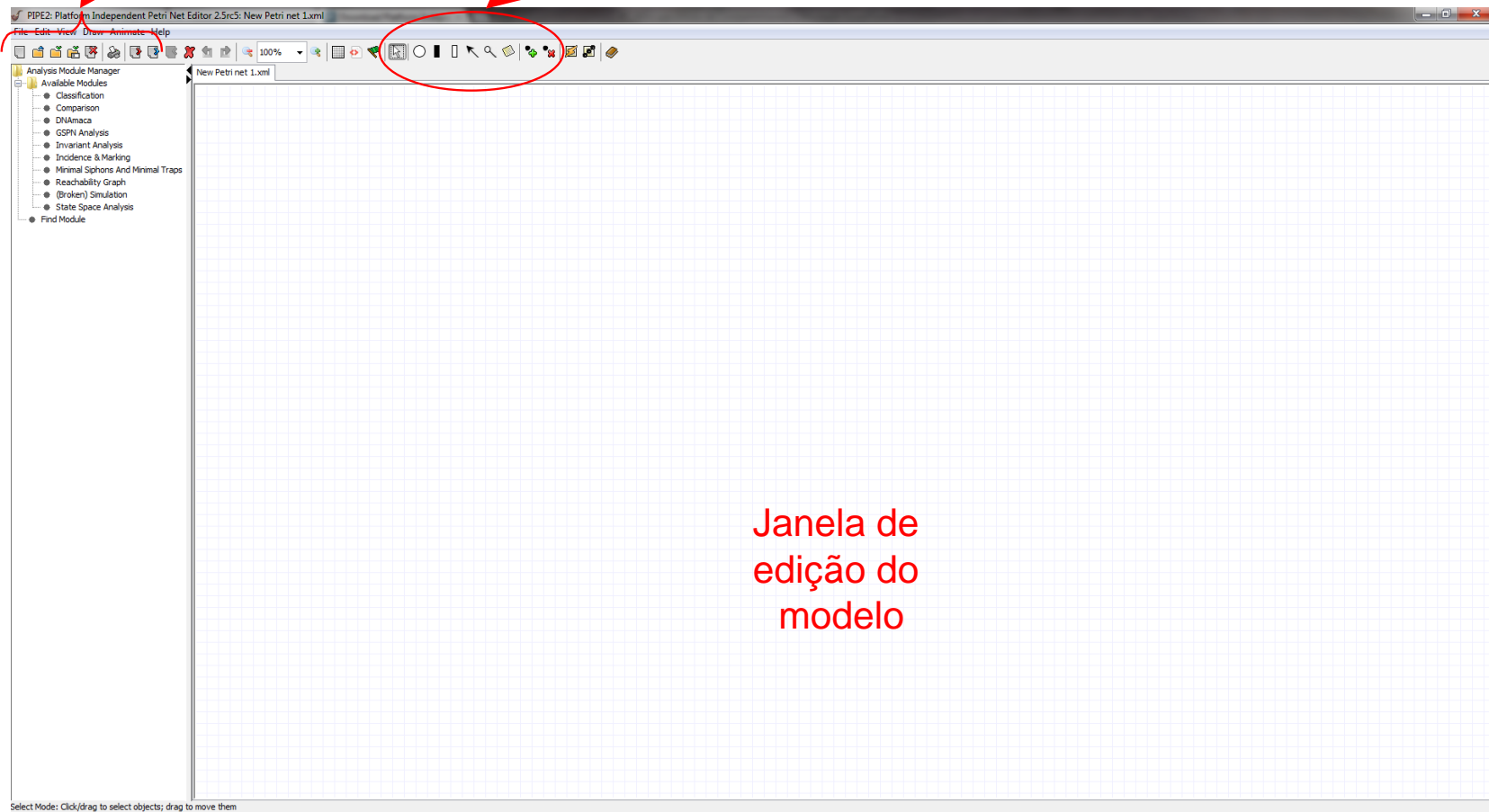

Janela de
edição do
modelo

PIPE2: Software de Simulação de Redes de Petri

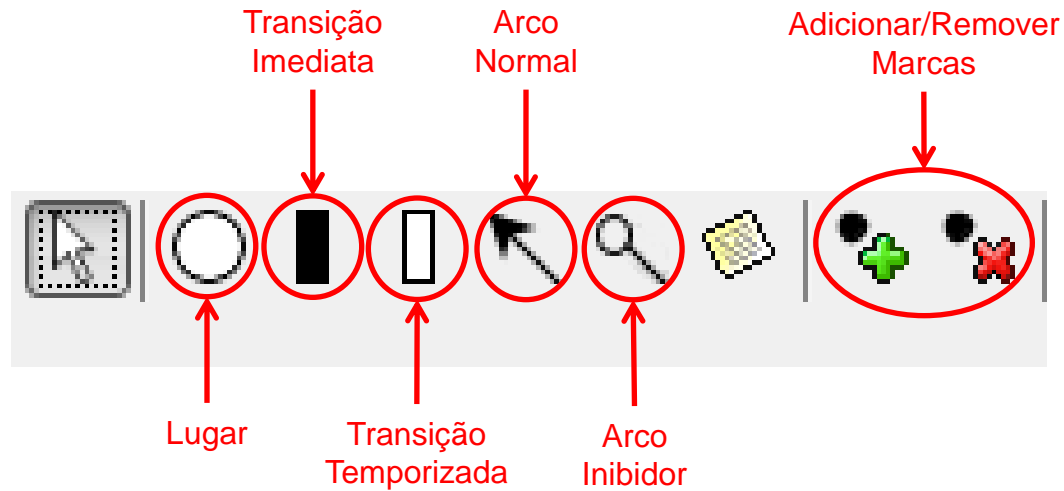

Metodologia

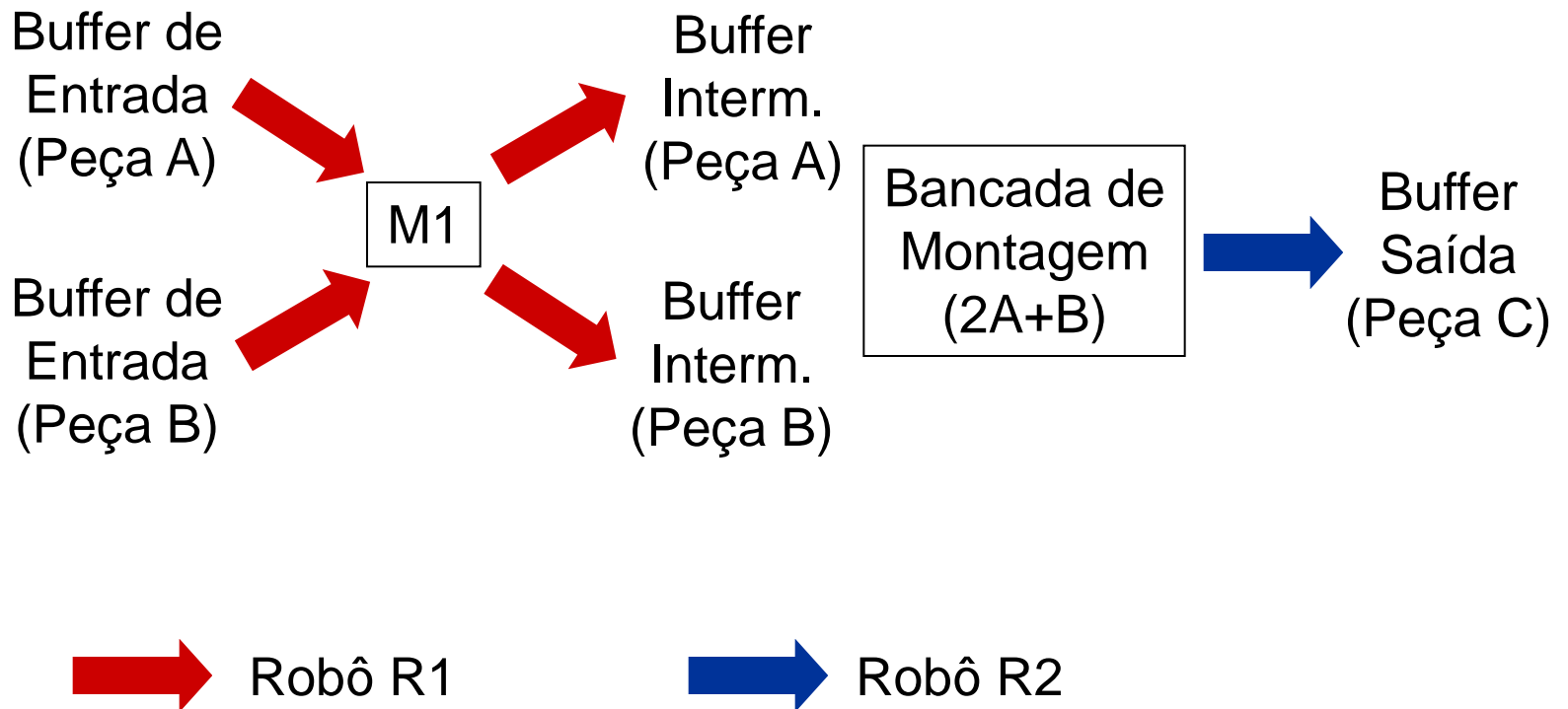

Metodologia

Buffers viram lugares com capacidade elevada

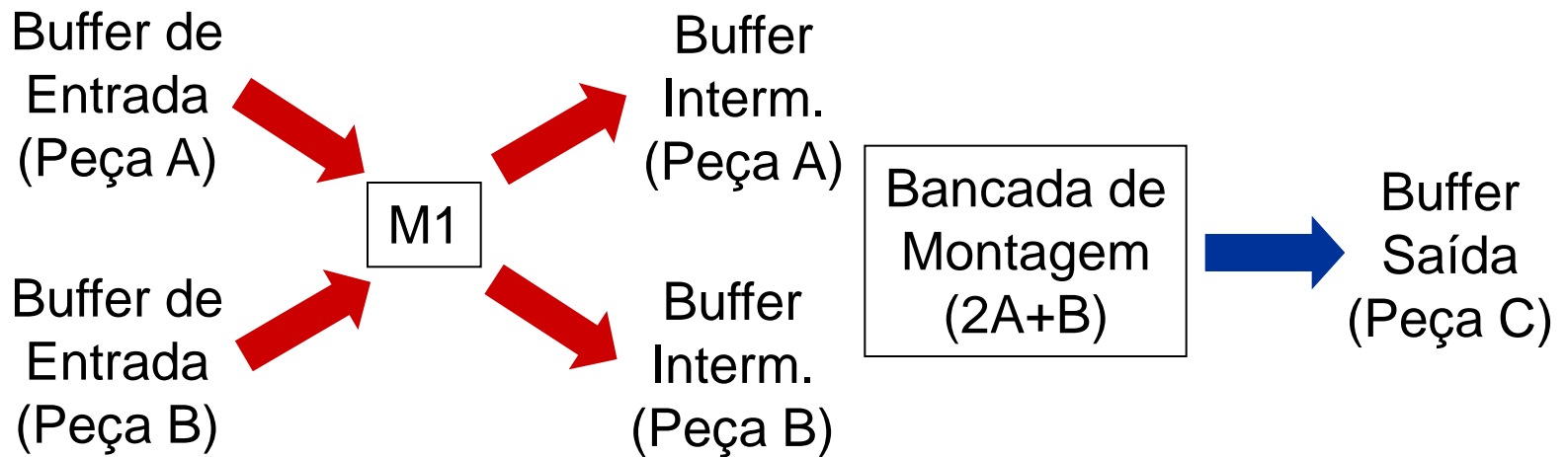

 Robô R1

 Robô R2

Metodologia

Buffers viram lugares com capacidade elevada

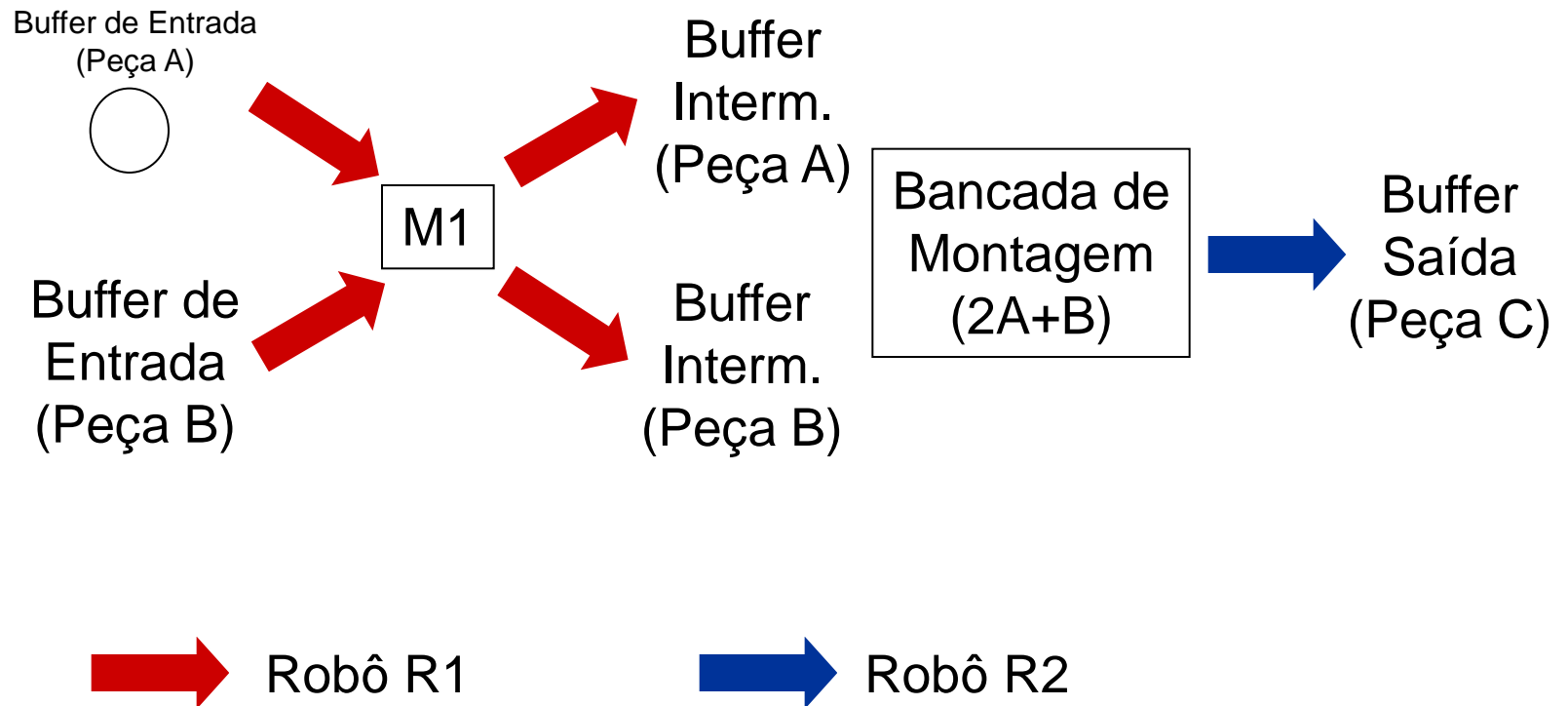

Metodologia

Buffers viram lugares com capacidade elevada

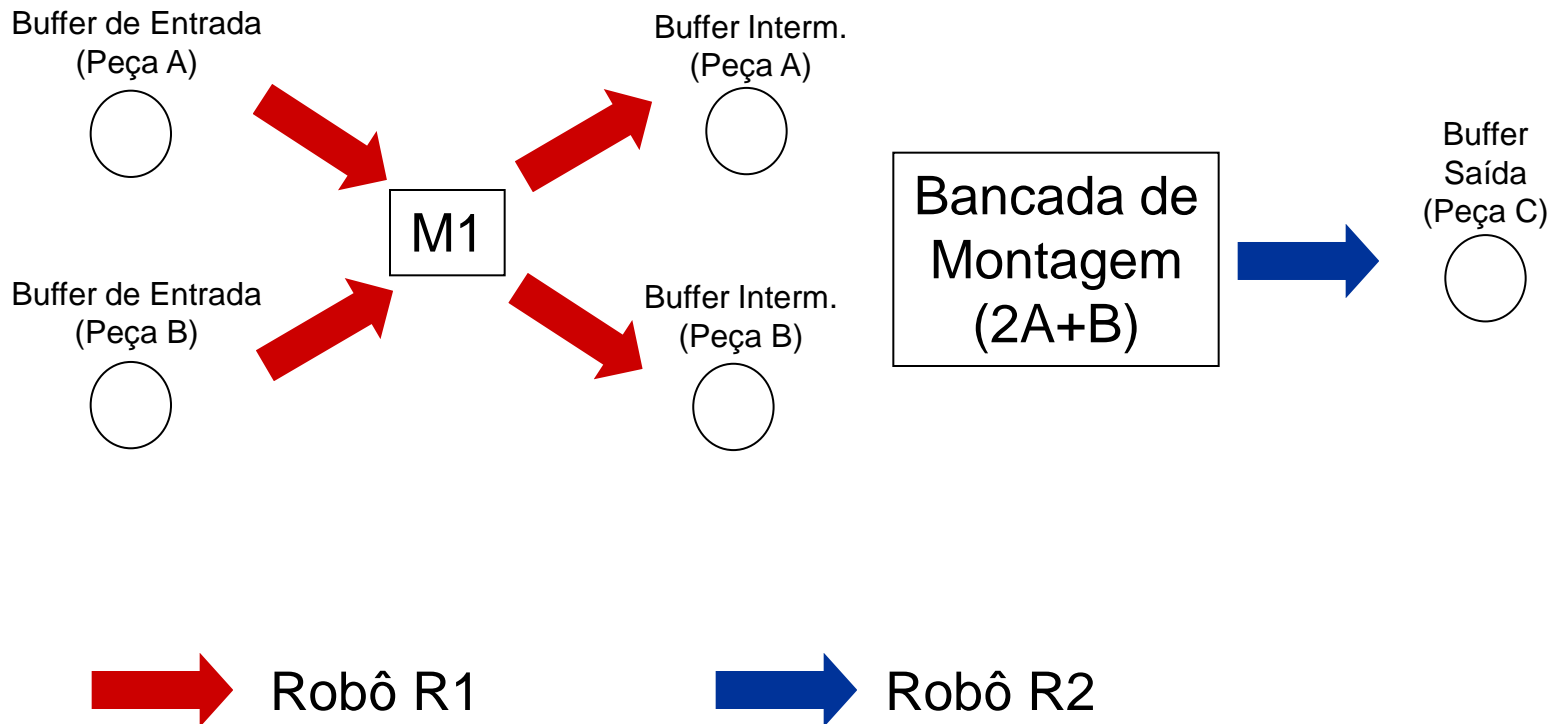

Metodologia

Operações viram lugares com capacidade simples

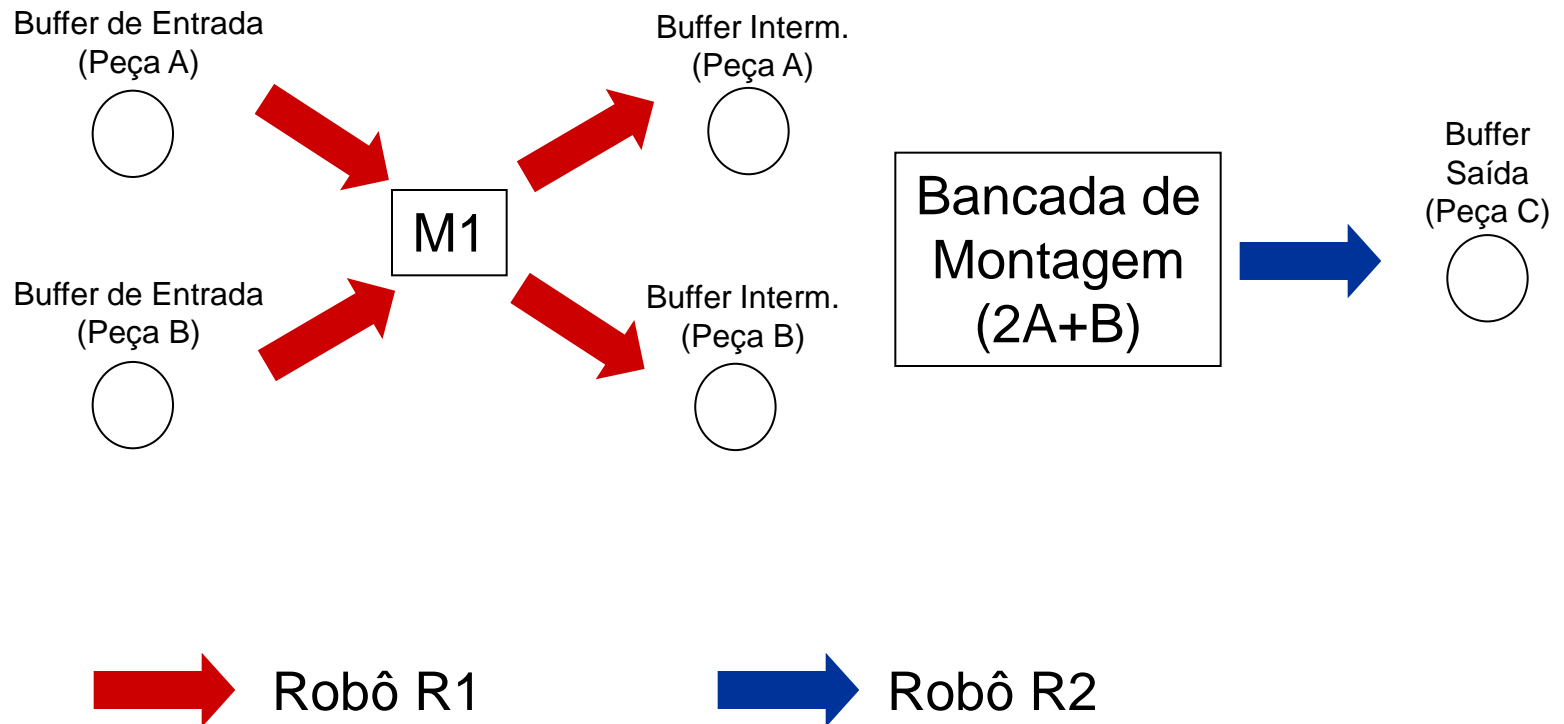

Metodologia

Operações viram lugares com capacidade simples

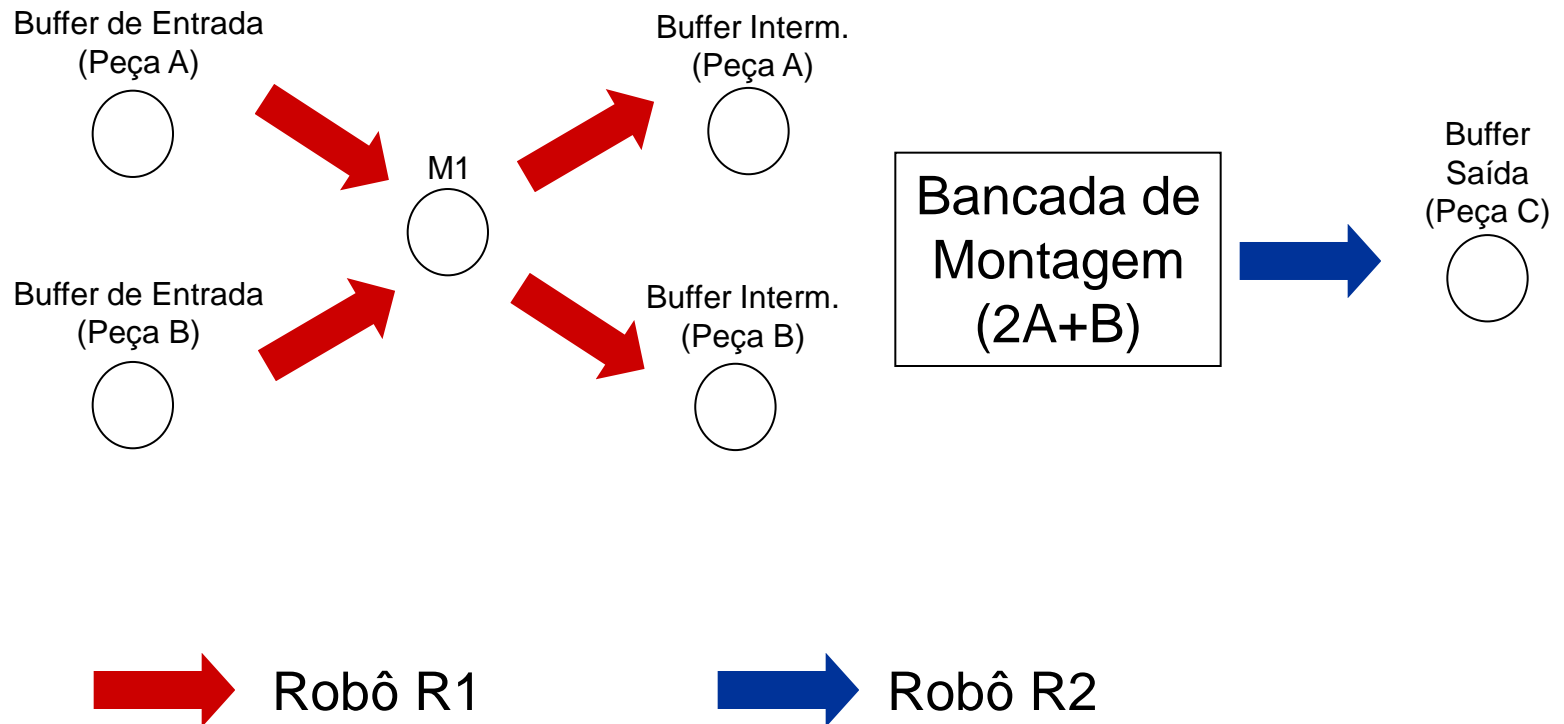

Metodologia

Operações viram lugares com capacidade simples

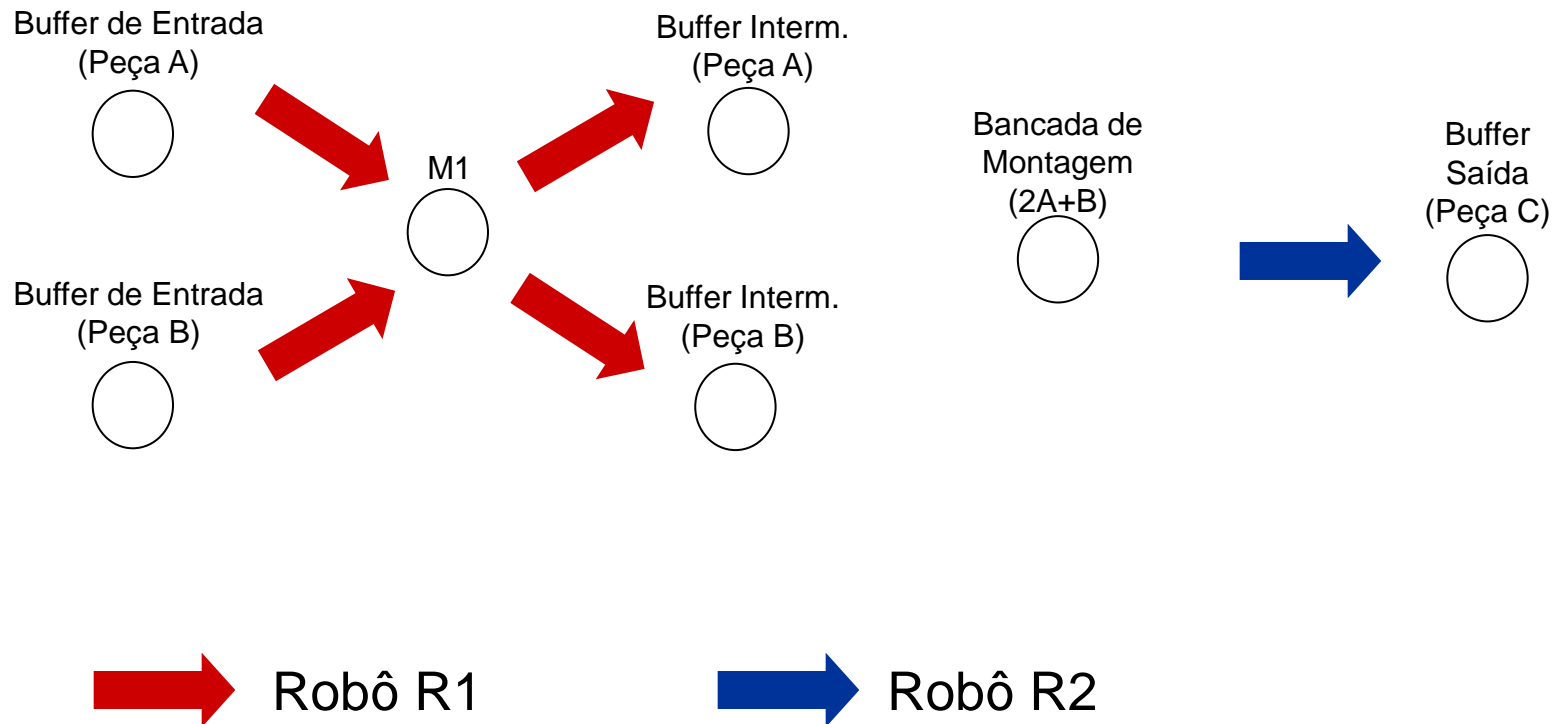

Metodologia

Processos de linhas diferentes se dividem para cada linha

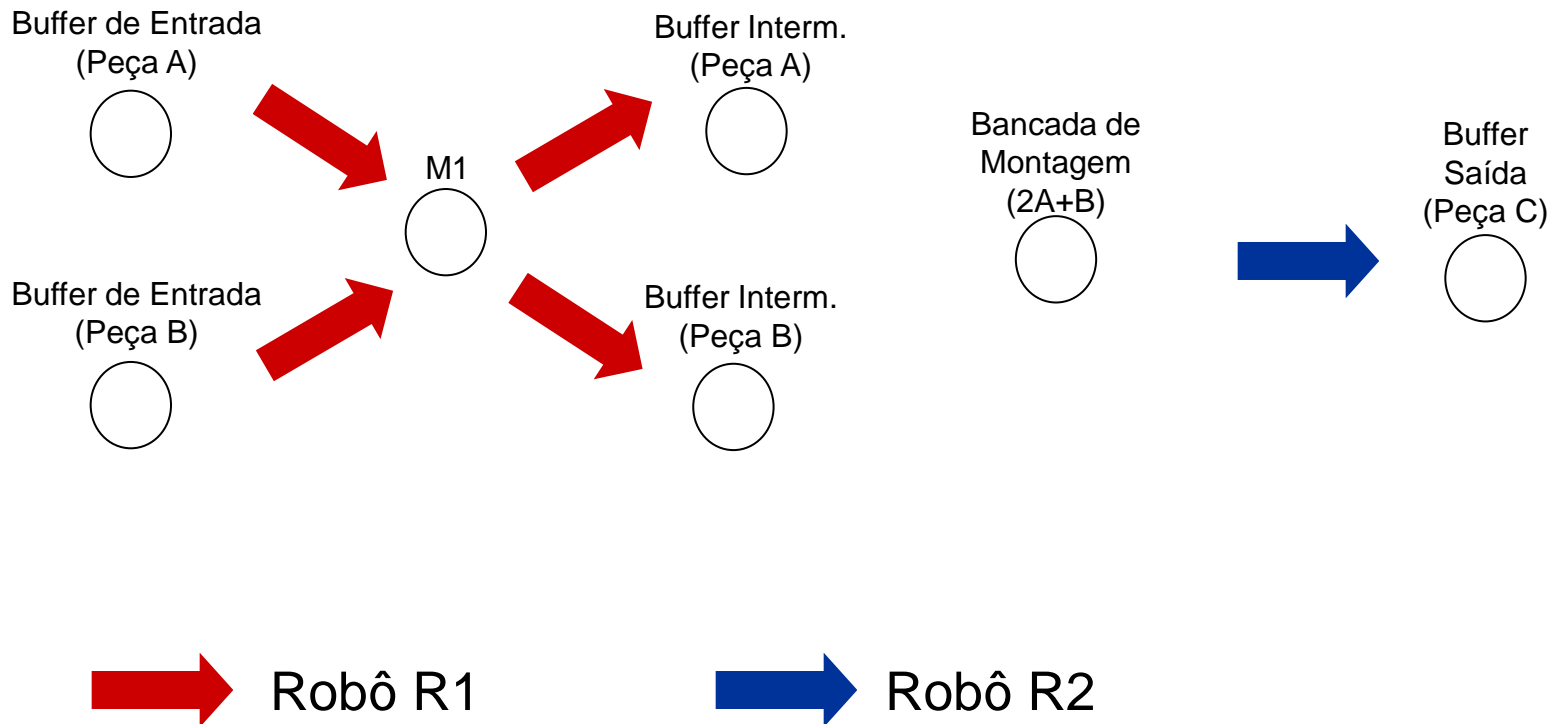

Metodologia

Processos de linhas diferentes se dividem para cada linha

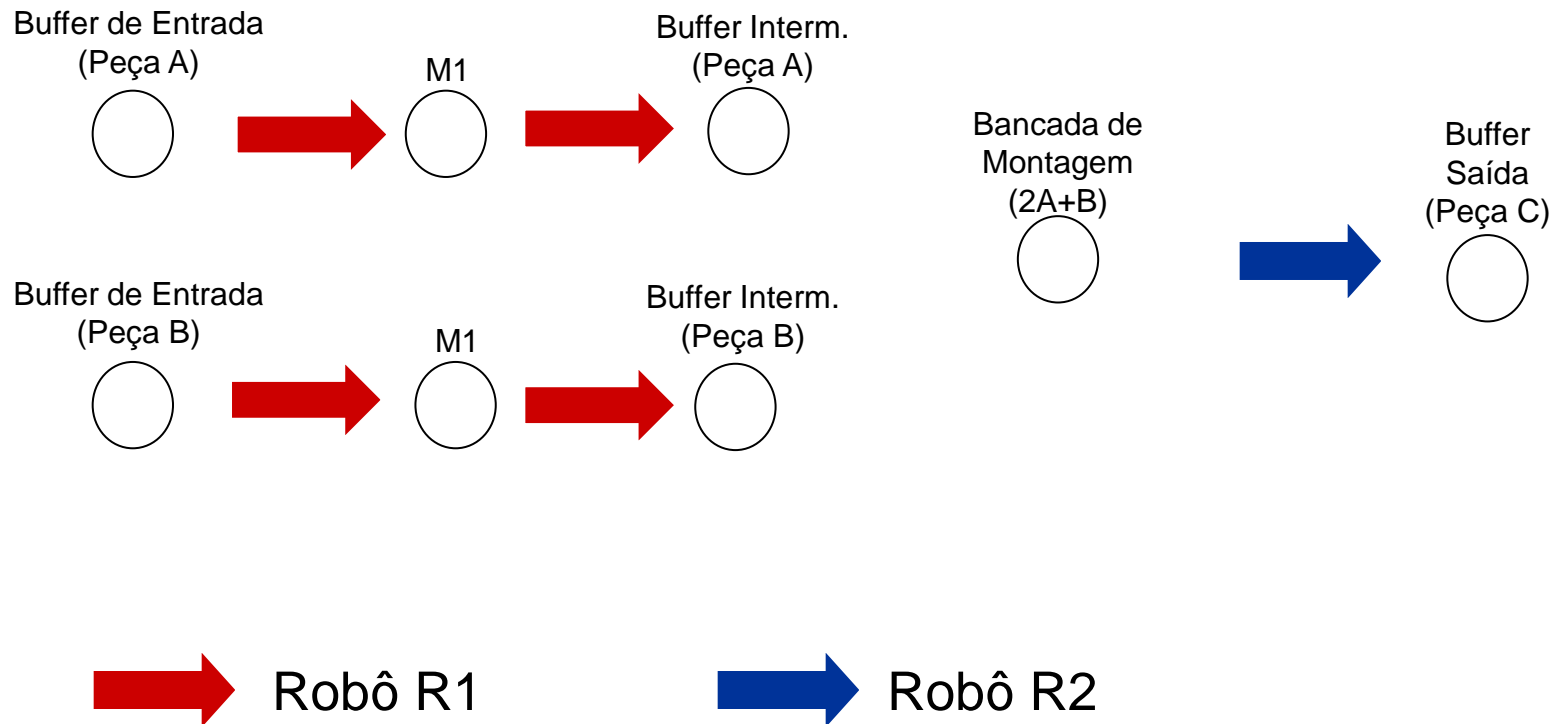

Metodologia

Transportes viram por lugares com capacidade simples

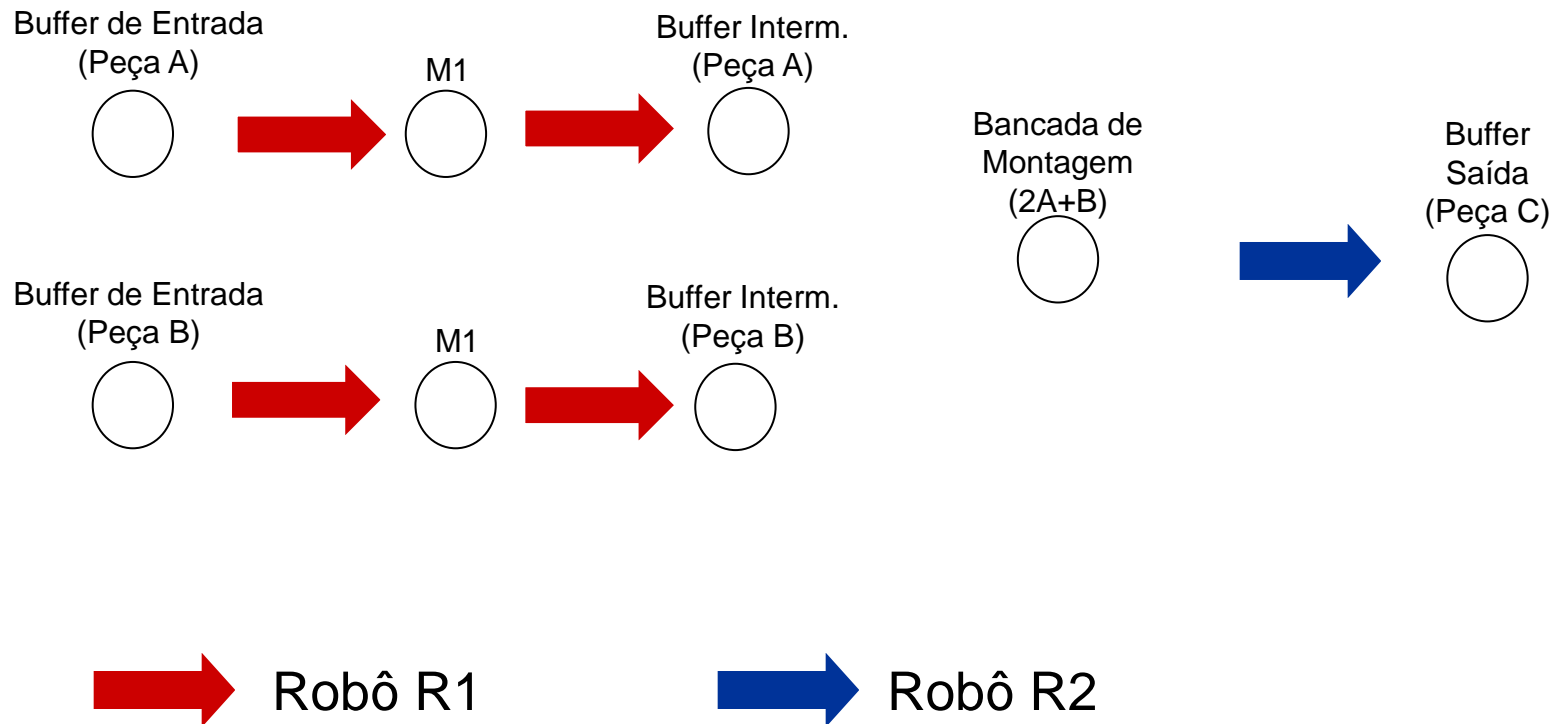

Metodologia

Transportes viram por lugares com capacidade simples

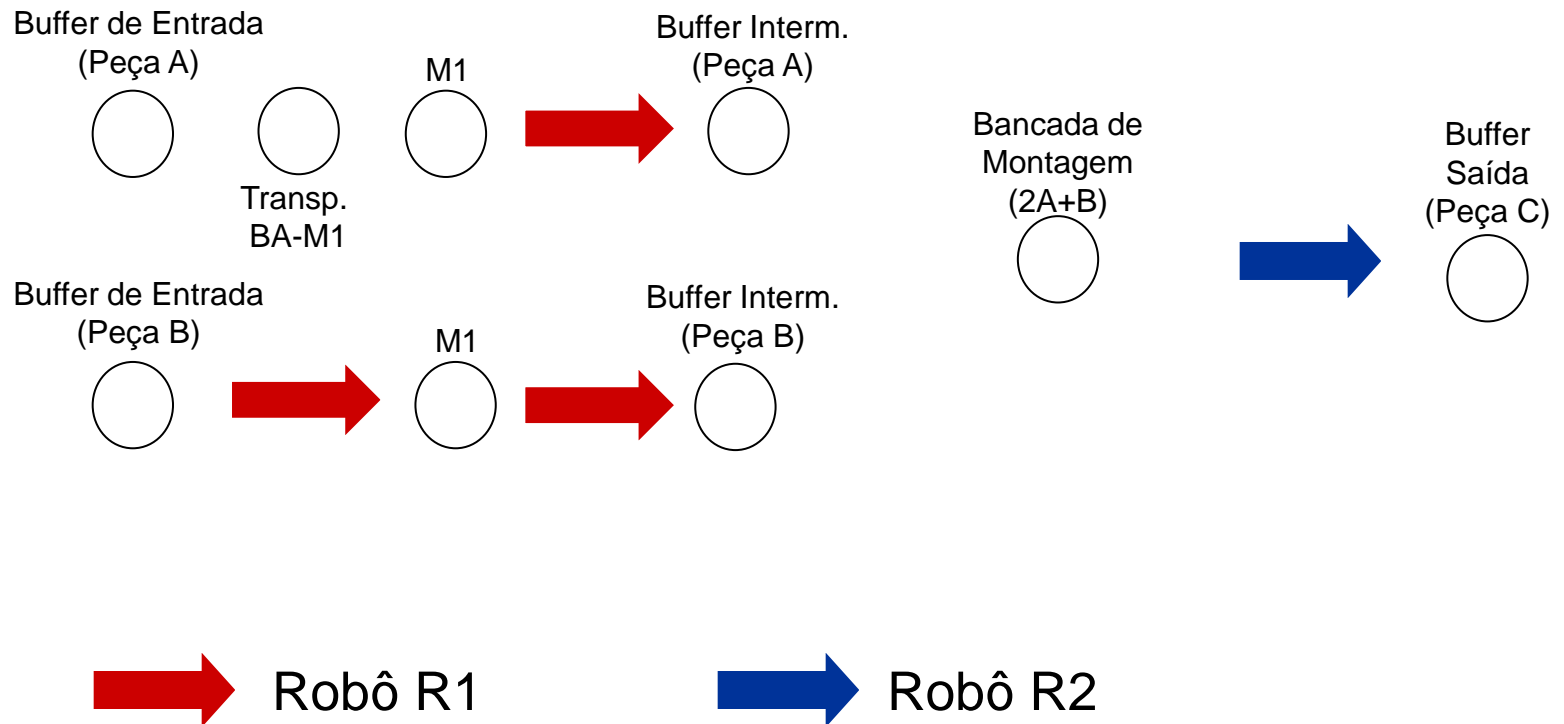

Metodologia

Transportes viram por lugares com capacidade simples

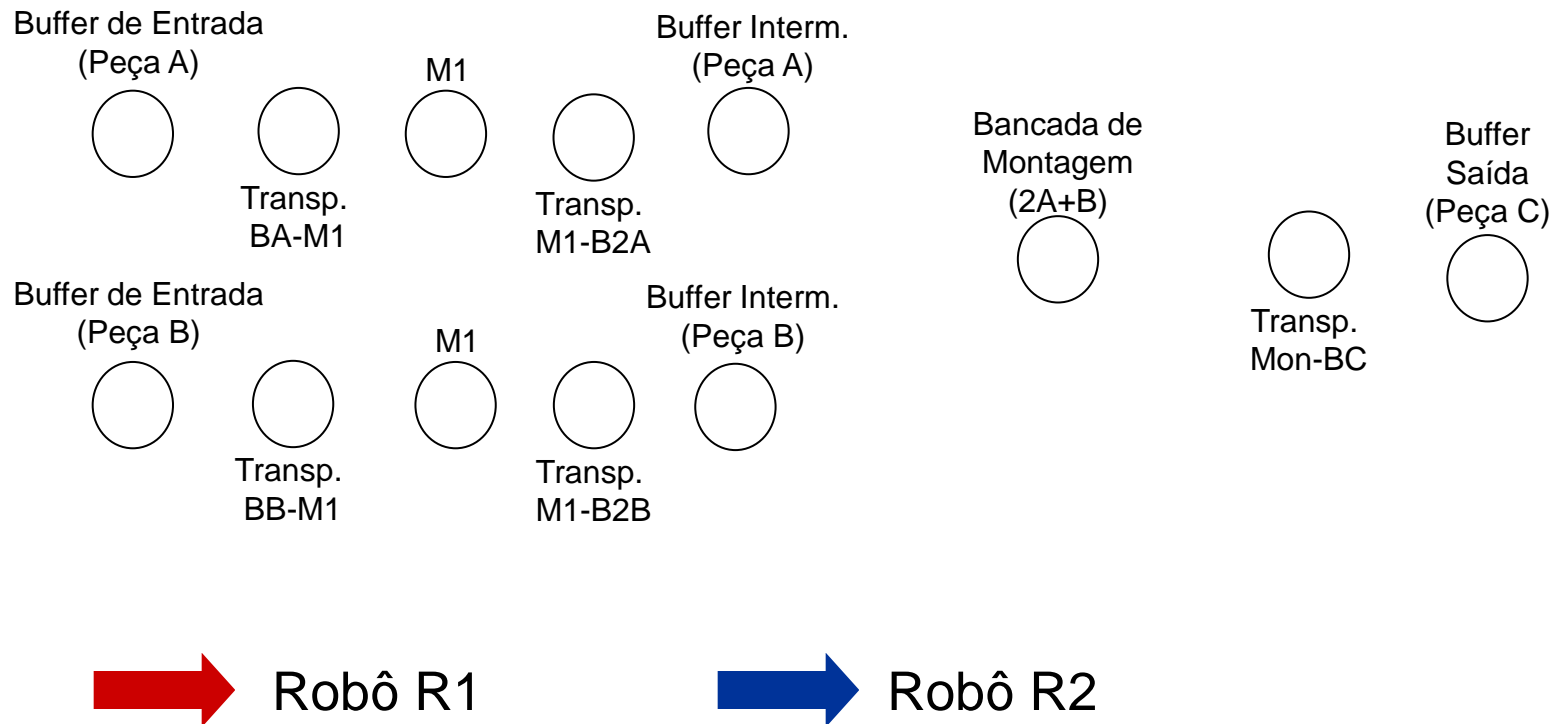

Metodologia

Coloca-se as transições entre os lugares da rede garantindo as características dos SEDs

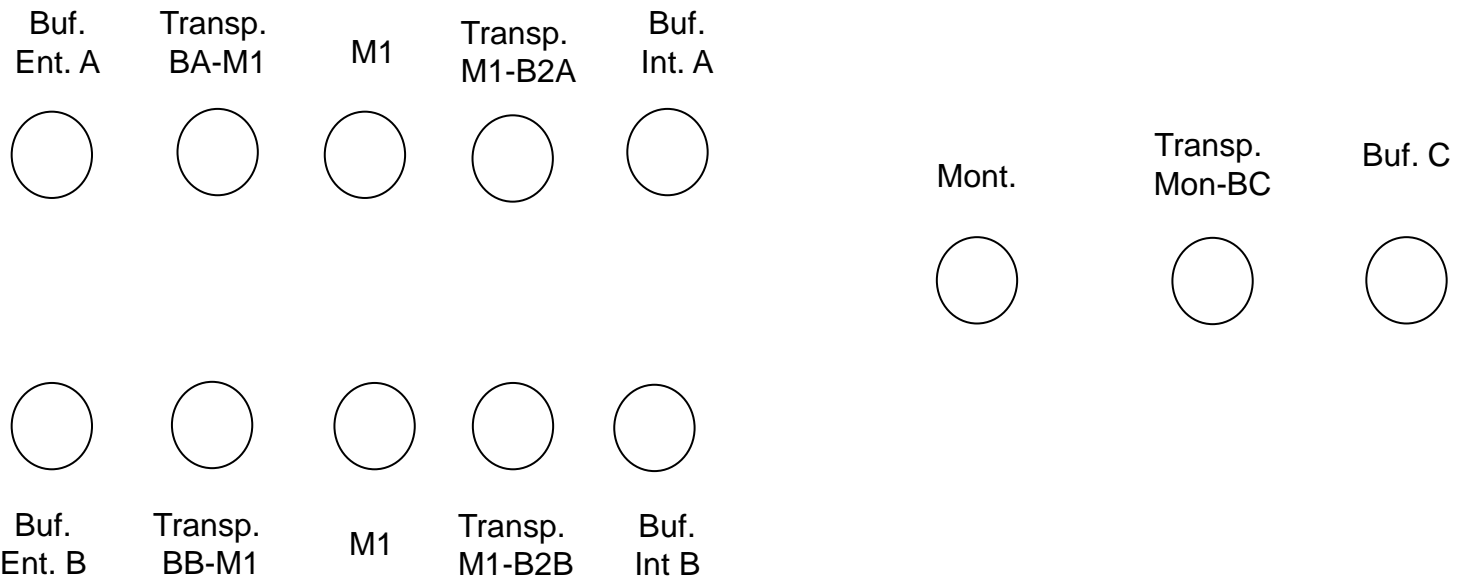

Metodologia

Coloca-se as transições entre os lugares da rede garantindo as características dos SEDs

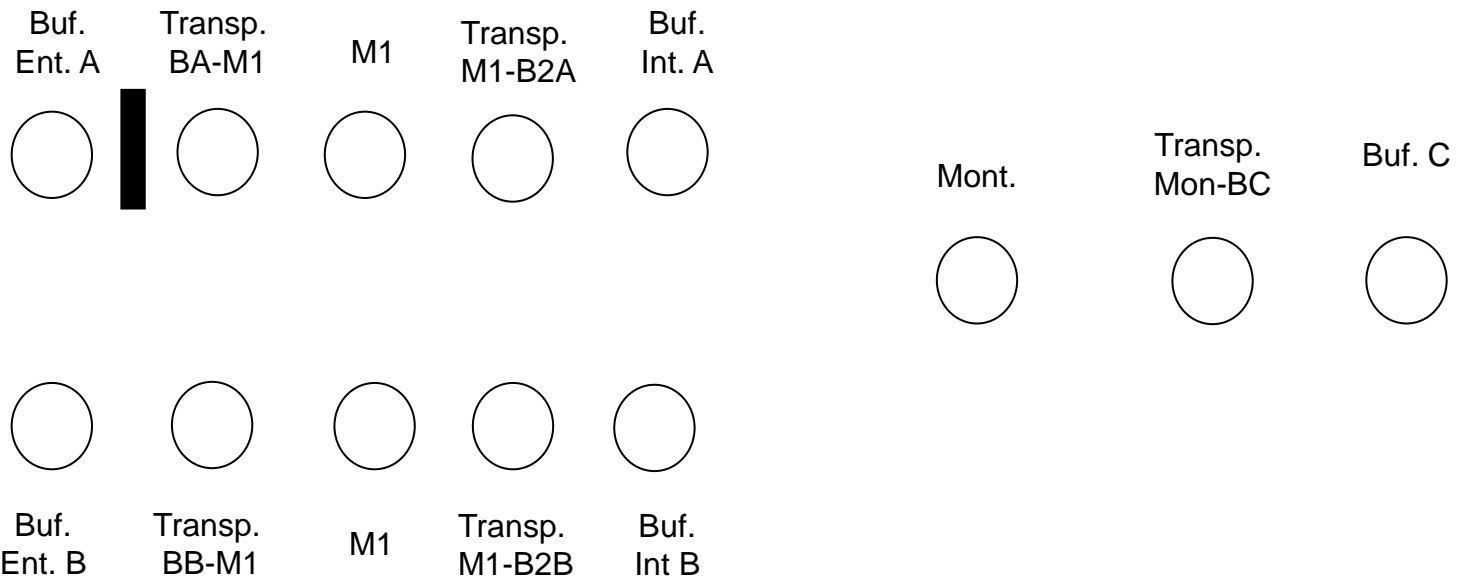

Metodologia

Coloca-se as transições entre os lugares da rede garantindo as características dos SEDs

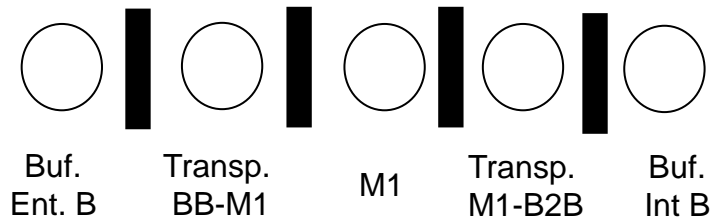
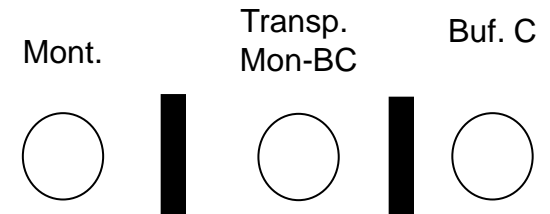

Metodologia

Coloca-se as transições entre os lugares da rede garantindo as características dos SEDs

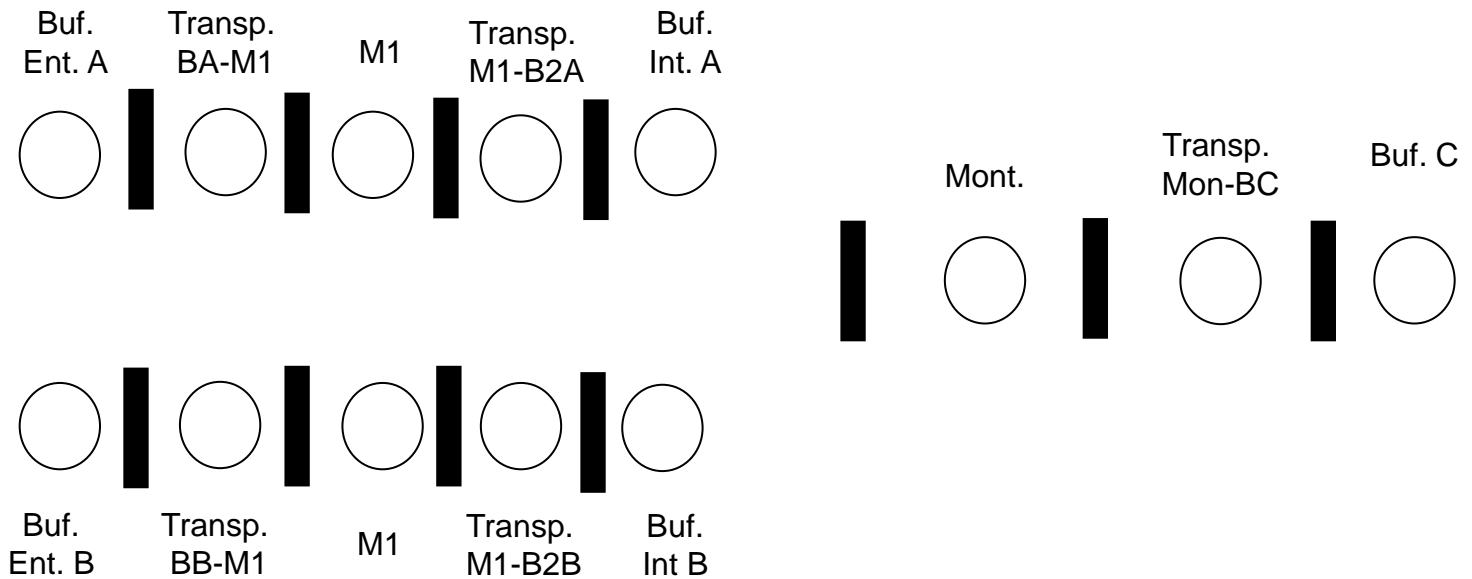

Metodologia

Liga-se os arcos dos lugares para as transições e das transições para os lugares e coloca-se os pesos

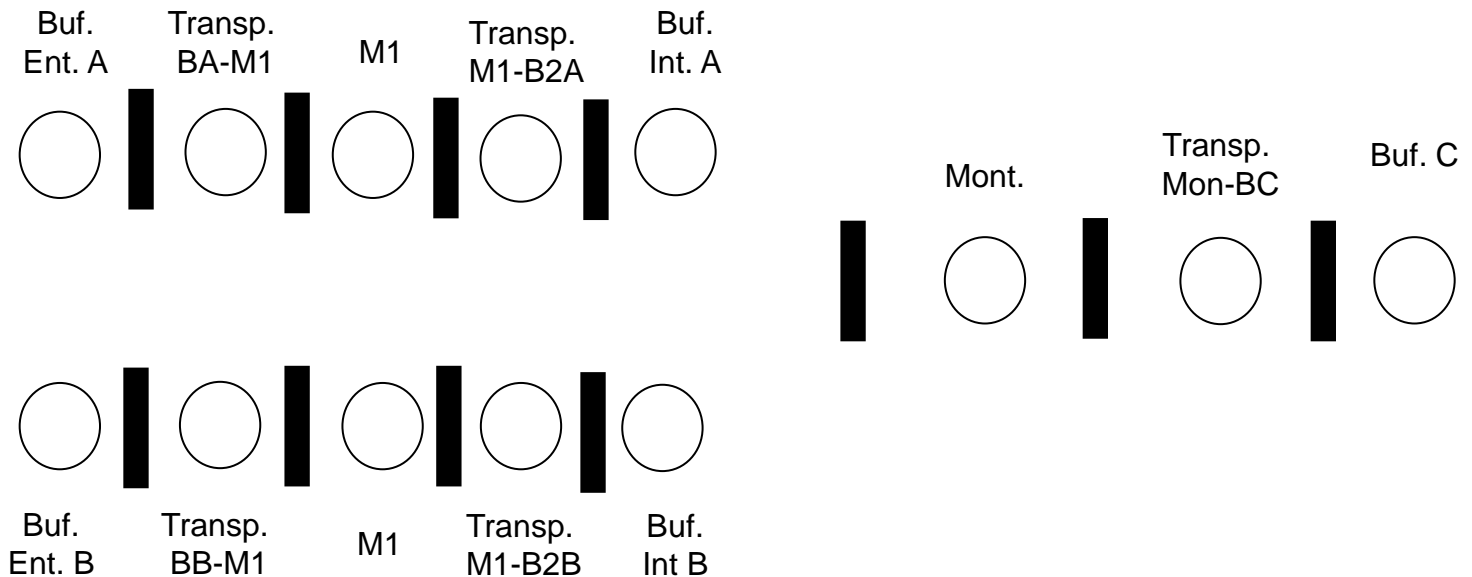

Metodologia

Liga-se os arcos dos lugares para as transições e das transições para os lugares e coloca-se os pesos

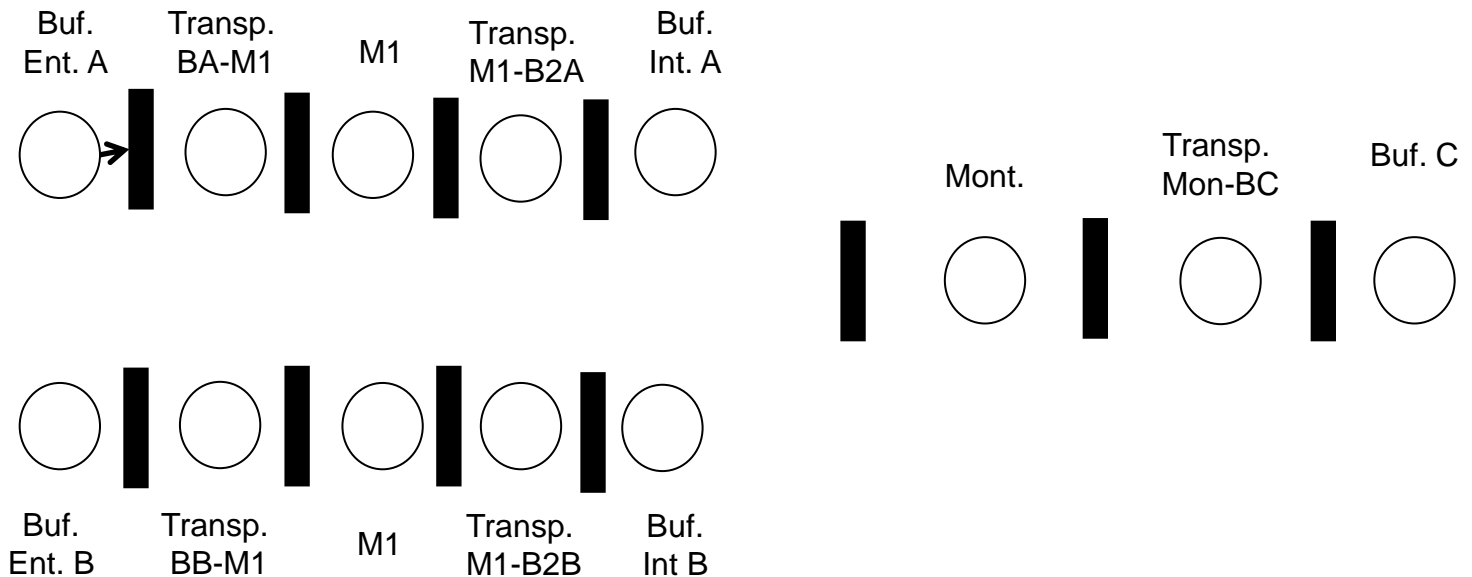

Metodologia

Liga-se os arcos dos lugares para as transições e das transições para os lugares e coloca-se os pesos

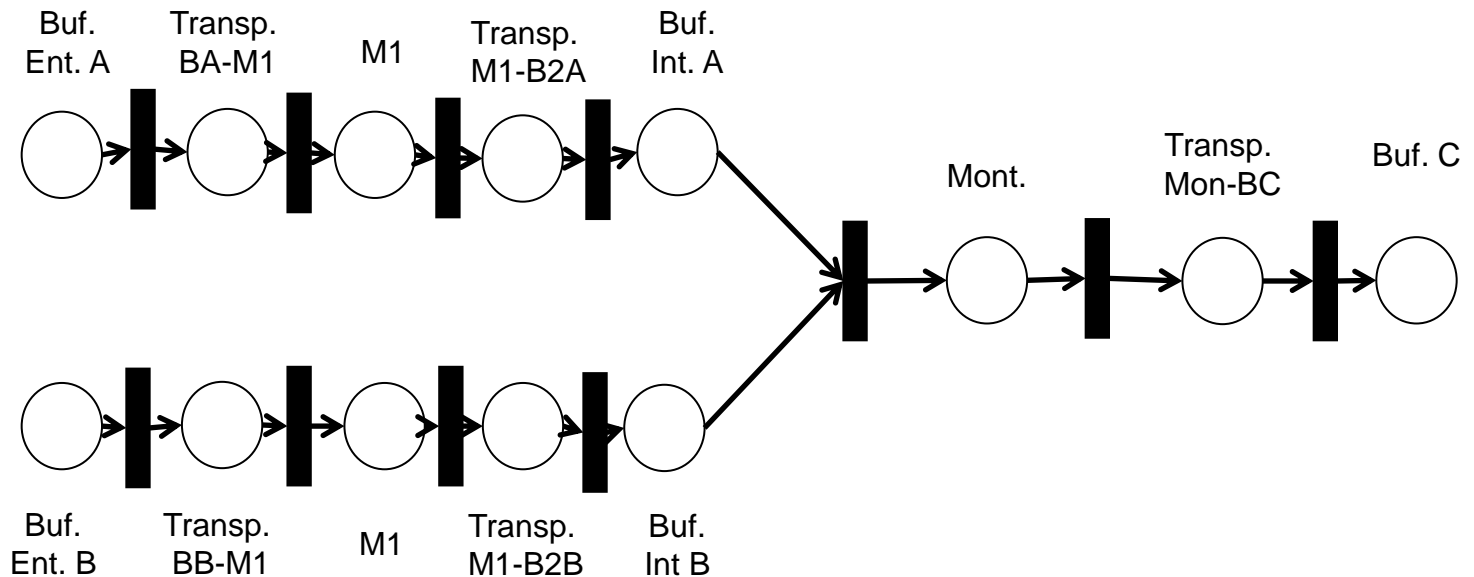

Metodologia

Liga-se os arcos dos lugares para as transições e das transições para os lugares e coloca-se os pesos

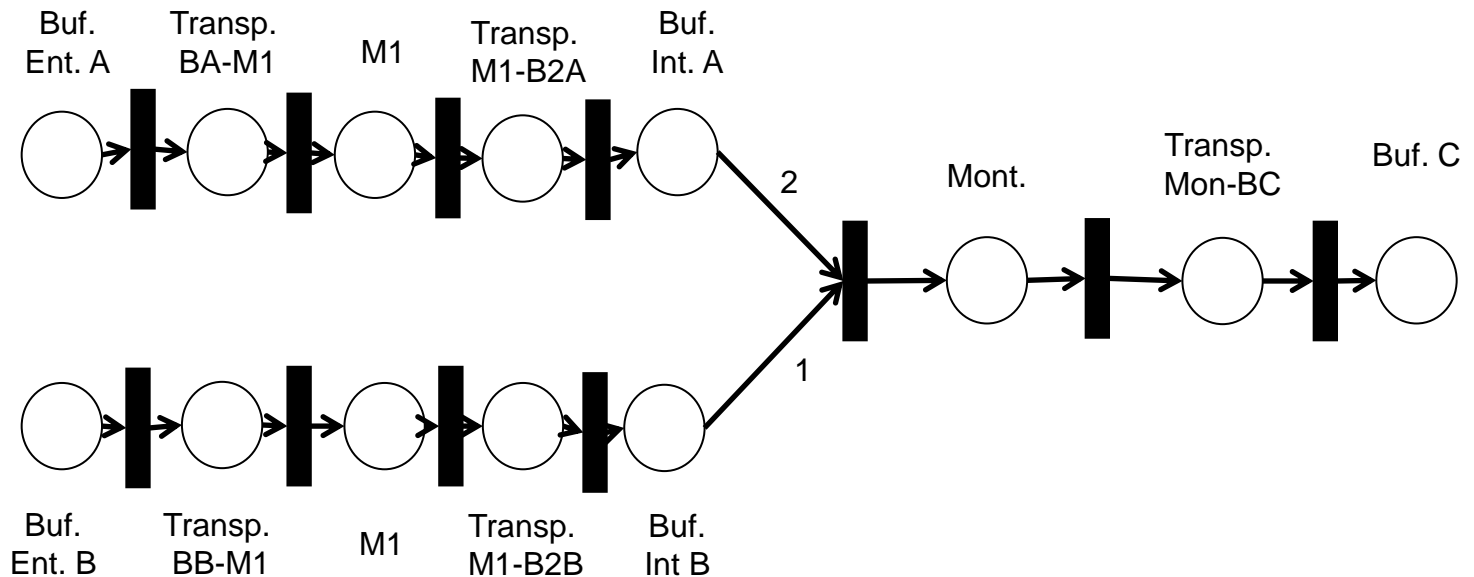

Metodologia

Aloca-se os recursos

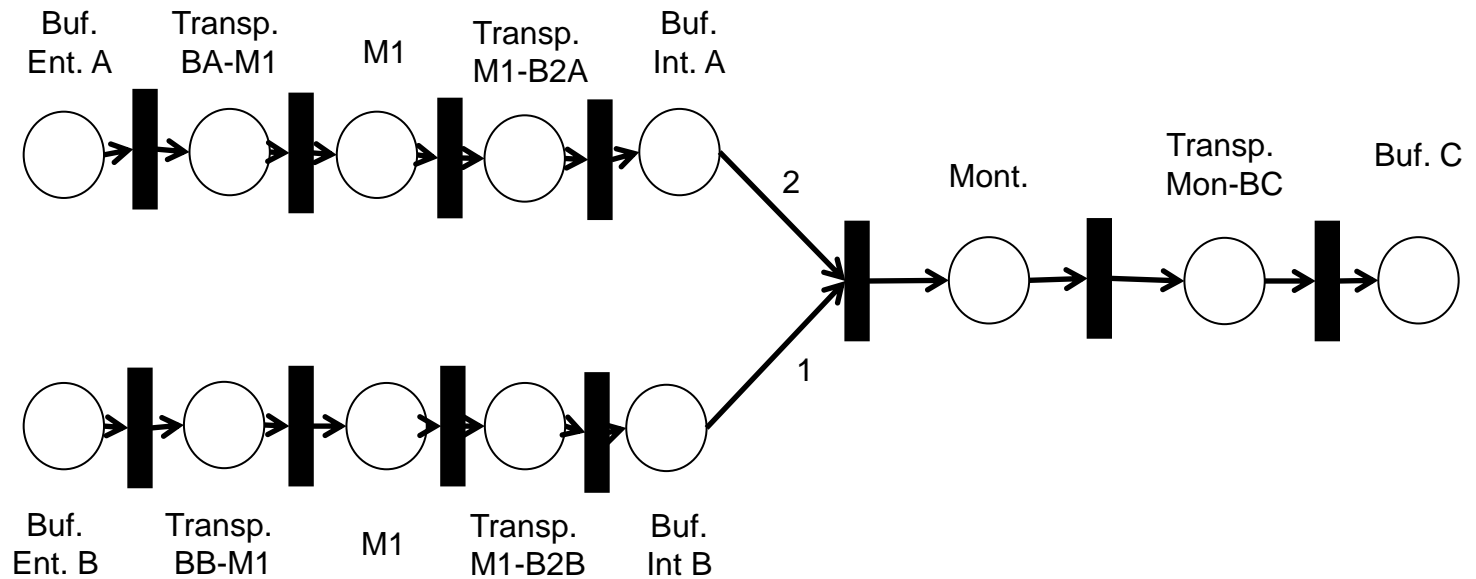

Metodologia

Aloca-se os recursos

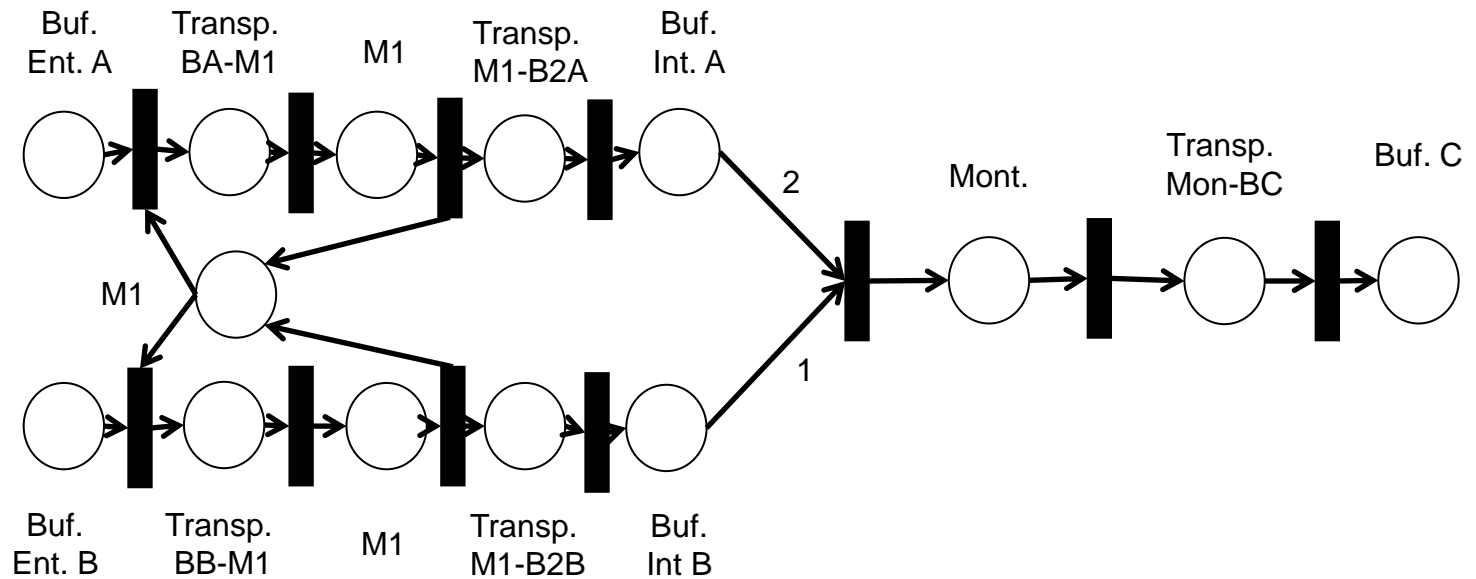

Metodologia

Aloca-se os recursos

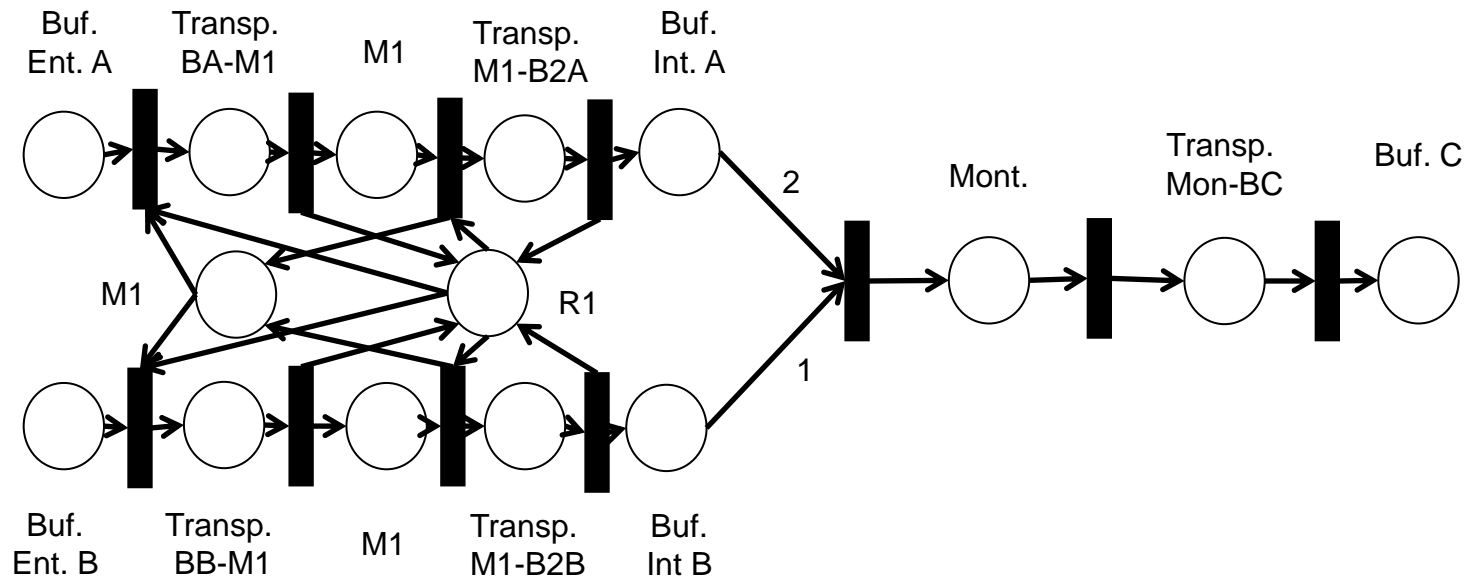

Metodologia

Aloca-se os recursos

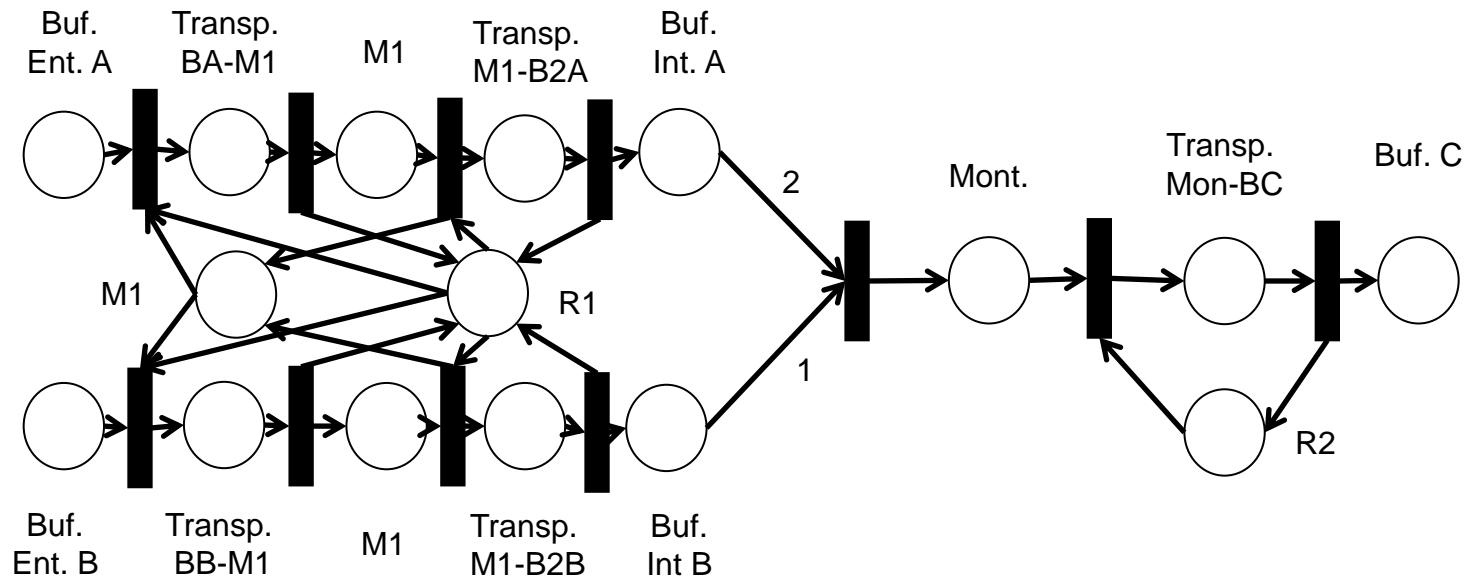

Metodologia

Aloca-se os recursos

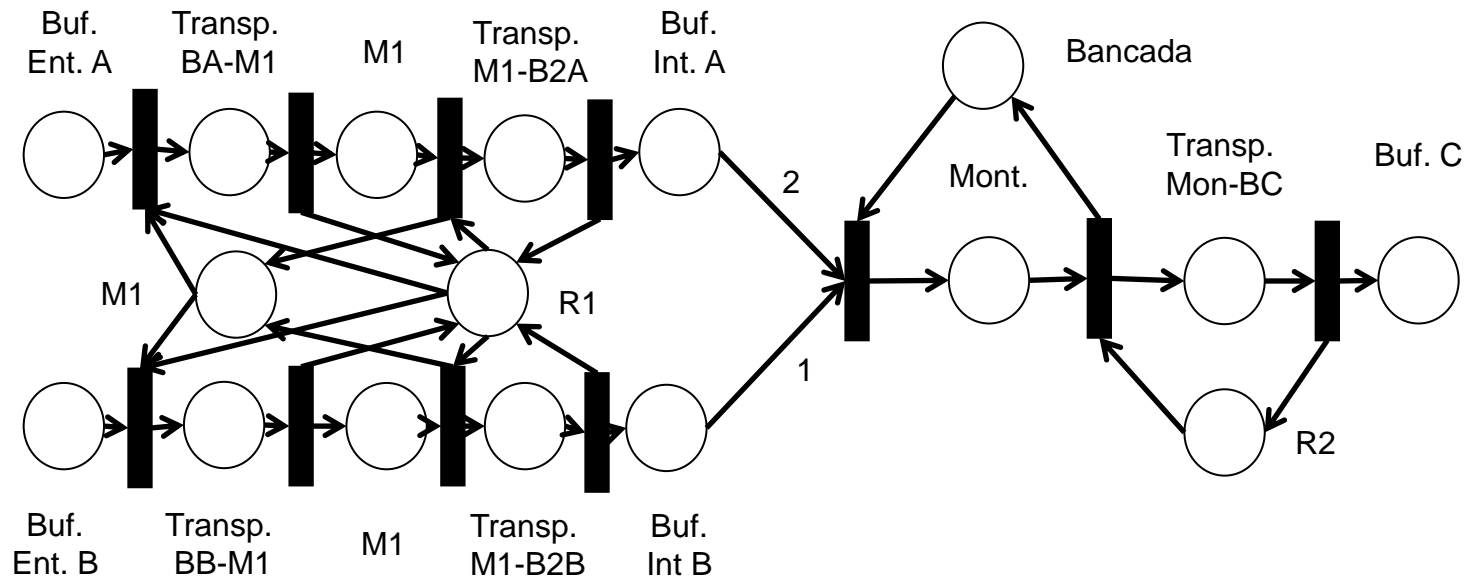

Metodologia

Configura os tempos das transições e as condições iniciais dos lugares

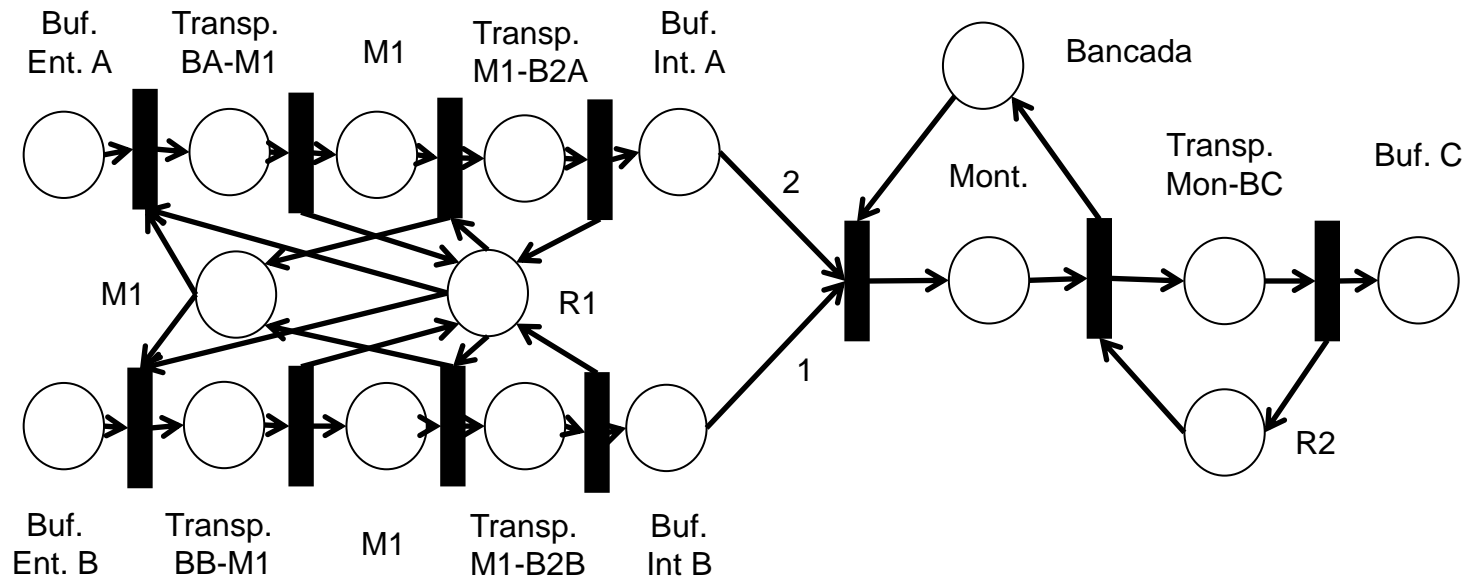

Metodologia

Configura os tempos das transições e as condições iniciais dos lugares

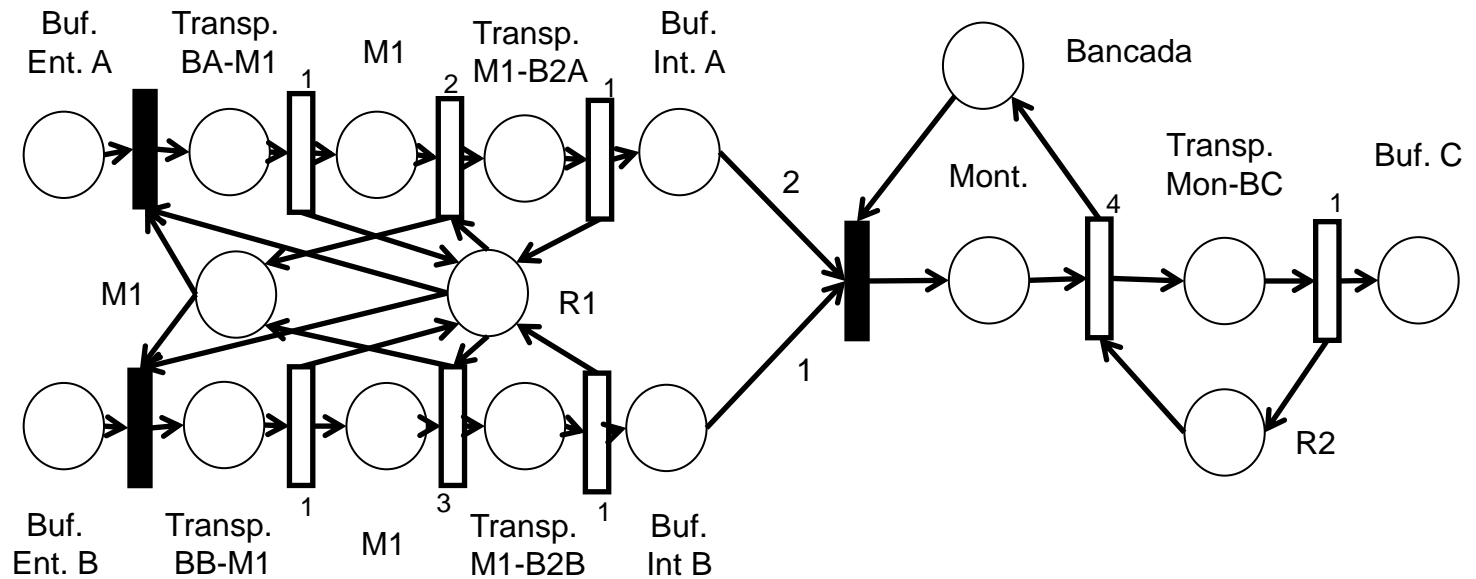

Metodologia

Configura os tempos das transições e as condições iniciais dos lugares

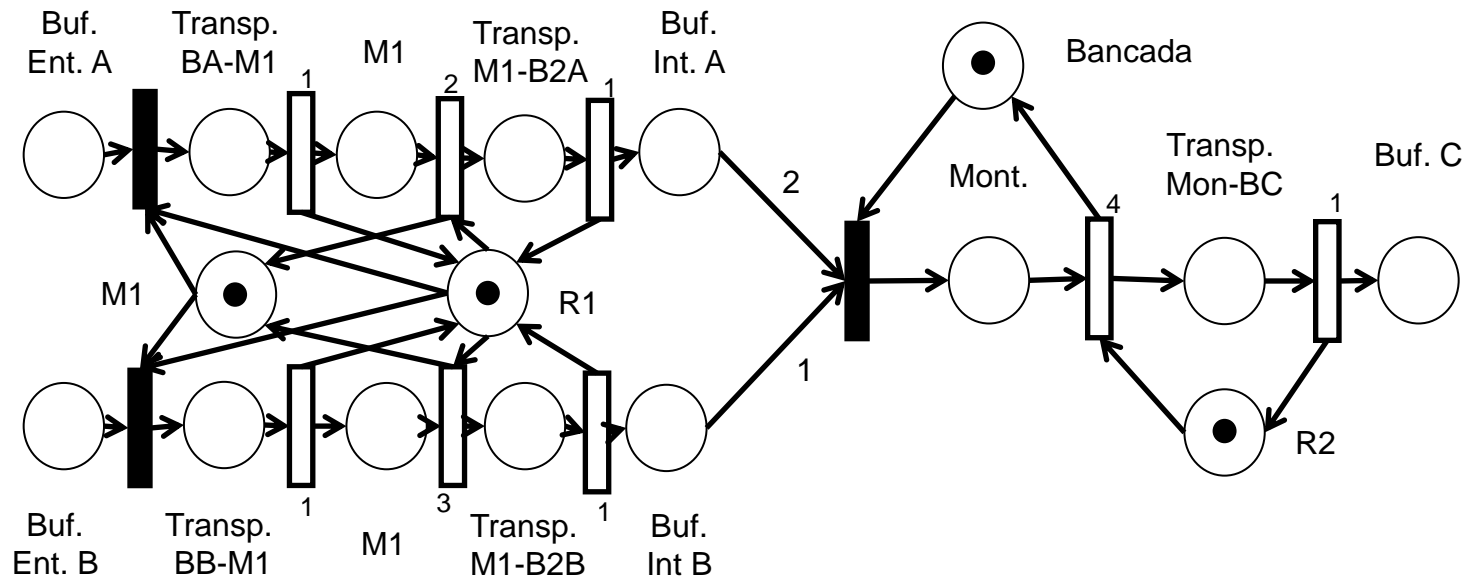

Metodologia

Configura os tempos das transições e as condições iniciais dos lugares

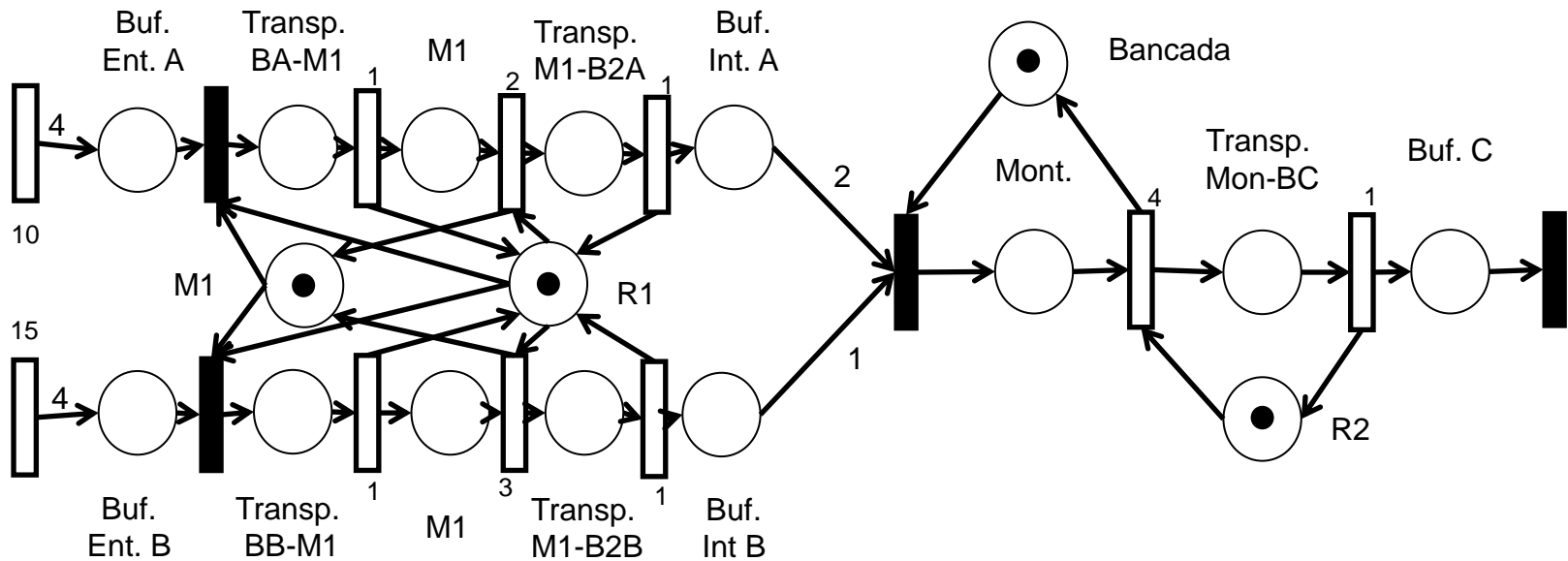

Metodologia

Simular

