

The slide features a decorative background on the left side with a repeating pattern of geometric shapes and arrows. A yellow horizontal bar spans across the top, and a green line starts from a small black circle with white dots on the left, curves over the yellow bar, and ends on the right side.

# Soldagem

Método de união localizada de materiais através de aquecimento a temperaturas adequadas com ou sem aplicação de pressão, podendo-se usar material de adição.

Definição da AWS

# Classificação

## Rotas para união de materiais metálicos

Operação

Método

Processo

União de  
Materiais

Fixação  
Mecânica

Soldagem

Fixação por  
Adesivo

Fixação eletro-  
magnética

Soldagem  
por fusão

Soldagem no  
estado sólido

Brasagem e  
Solda Branda



# Processos de Soldagem

- ✚ Soldagem por fusão: utilizam fusão dos materiais a serem unidos.
- ✚ Soldagem no estado sólido: não ocorre fusão dos materiais a serem unidos ou de qualquer outro
- ✚ Brasagem: fusão somente do material de adição ( $T > 450\text{C}$ )
- ✚ Solda Branda: fusão somente do material de adição ( $T < 450\text{C}$ )



# Aplicações

- ✚ Fabricação: produção de manufaturados
- ✚ Manutenção e Reparos: Prolongamento da vida útil de peças e componentes
- ✚ Vantagens:
  - Meio barato de união de metais
  - Aplicáveis para a união de todos os metais comerciais
  - Propicia flexibilidade de projeto
  - Reduz o tempo e o custo de fabricação
  - Fácil de ser utilizado na recuperação e manutenção de produtos

# Soldagem por Oxi-gás

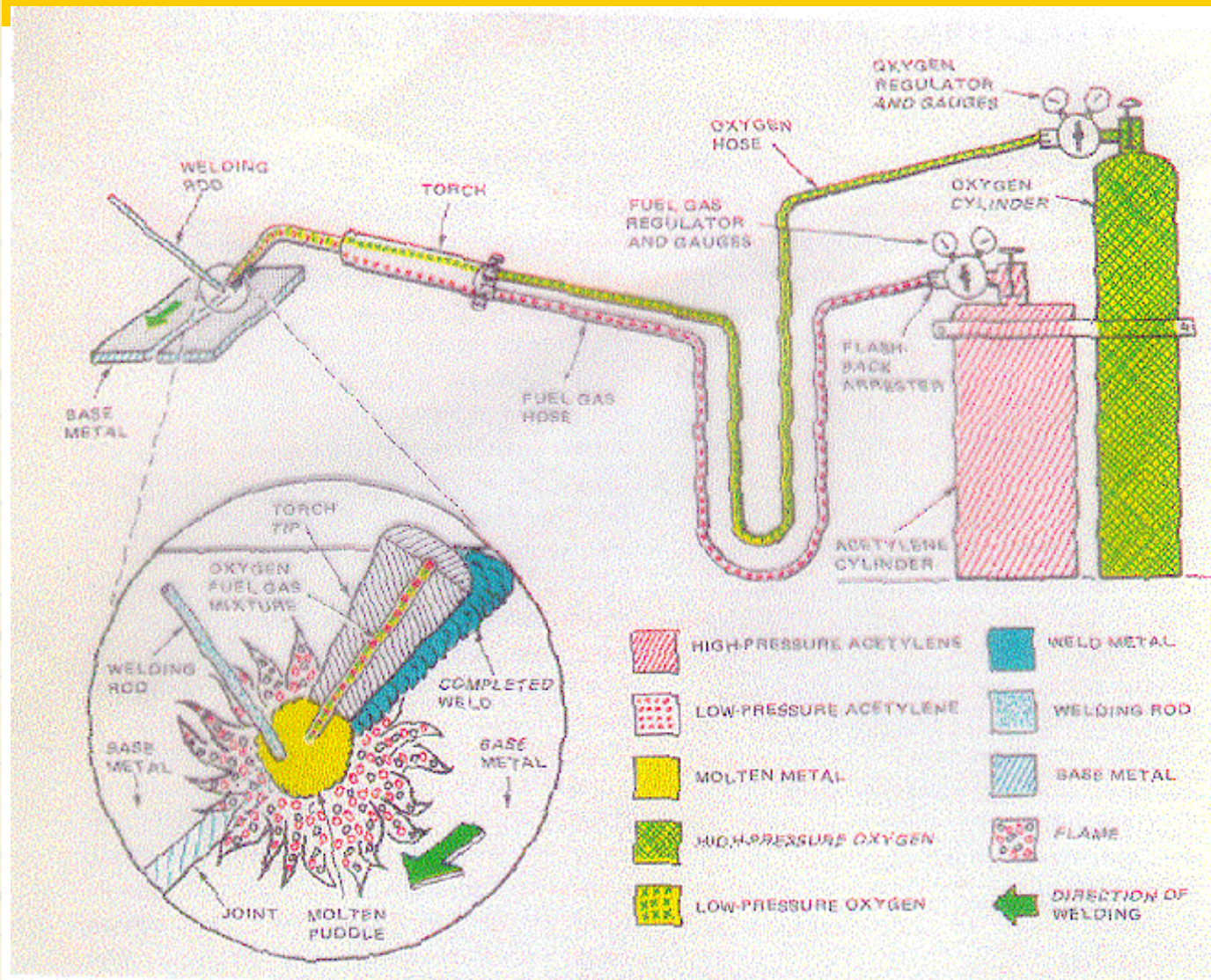

# Soldagem por Oxi-gás



Aço ao  
Carbono

# Tipos de Chama

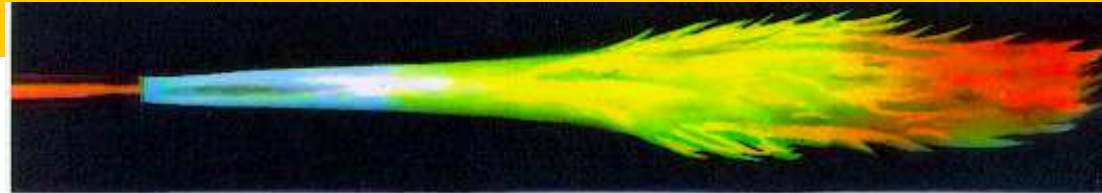

**Acetylene Burning in Atmosphere**  
Open fuel gas valve until smoke clears from flame.

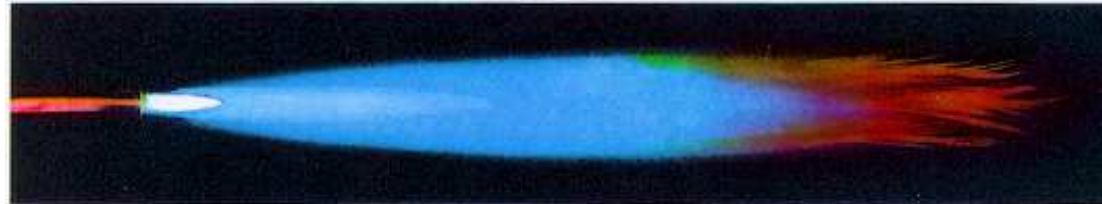

**Carburizing Flame**  
(Excess acetylene with oxygen.) Used for hard-facing and welding white metal

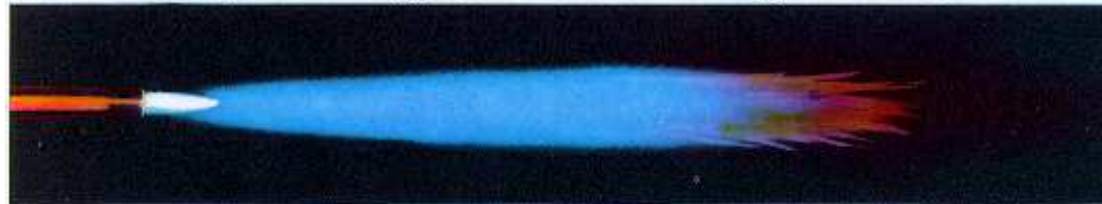

**Neutral Flame**  
(Acetylene and oxygen.) Temp. 5600 F. For fusion welding of steel and cast iron.

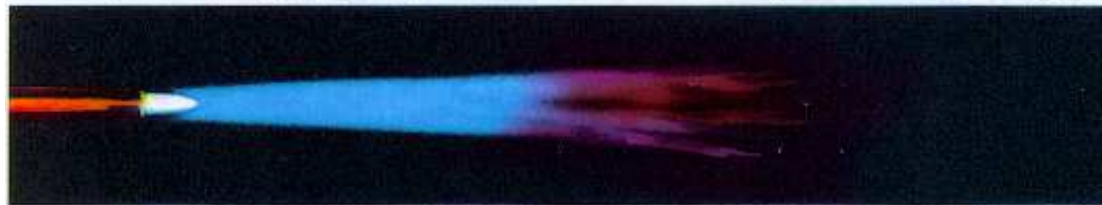

**Oxidizing Flame**  
(Acetylene and excess oxygen.) For braze welding with bronze rod.

# Soldagem a Arco Elétrico com Eletrodo Revestido (SAER)

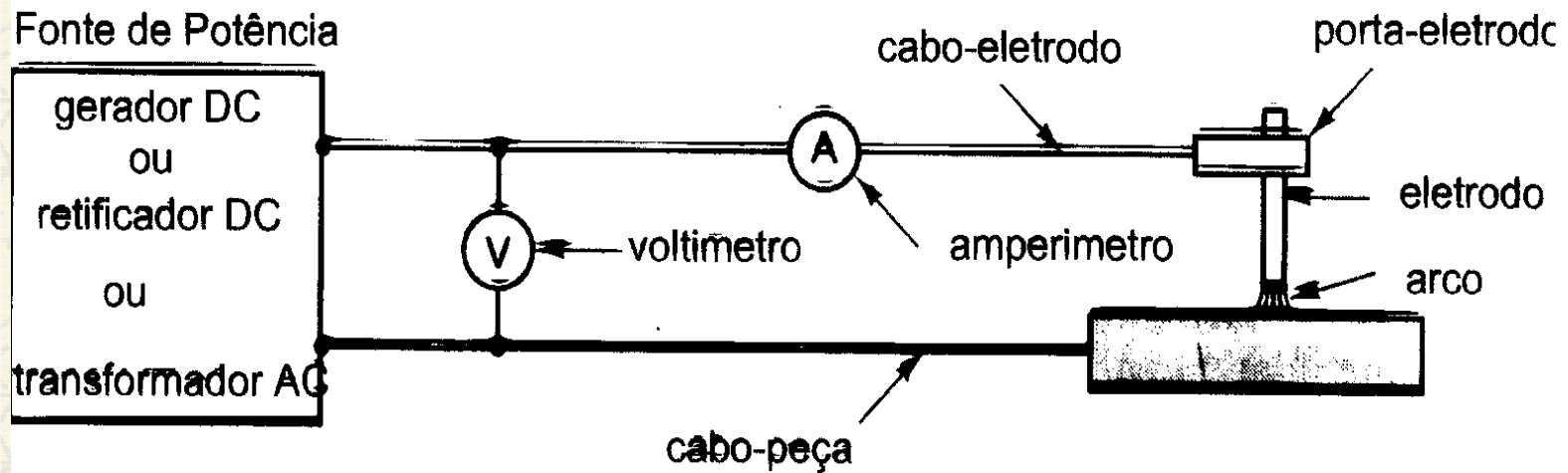



# ● Soldagem a Arco Elétrico com Eletrodo Revestido (SAER)

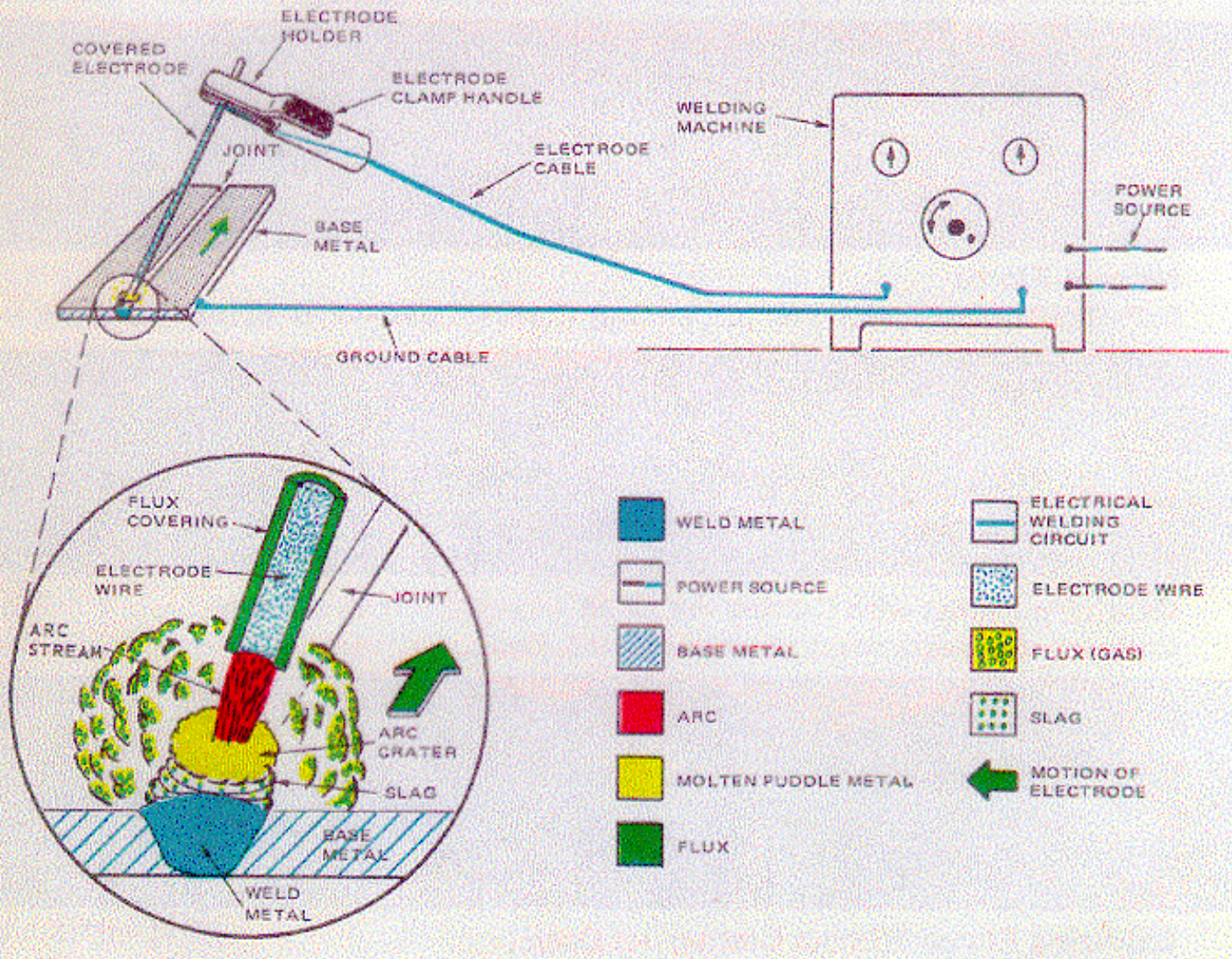

# ● Soldagem a Arco Elétrico com Eletrodo Revestido (SAER)



# Soldagem a Arco Submerso (SAS)

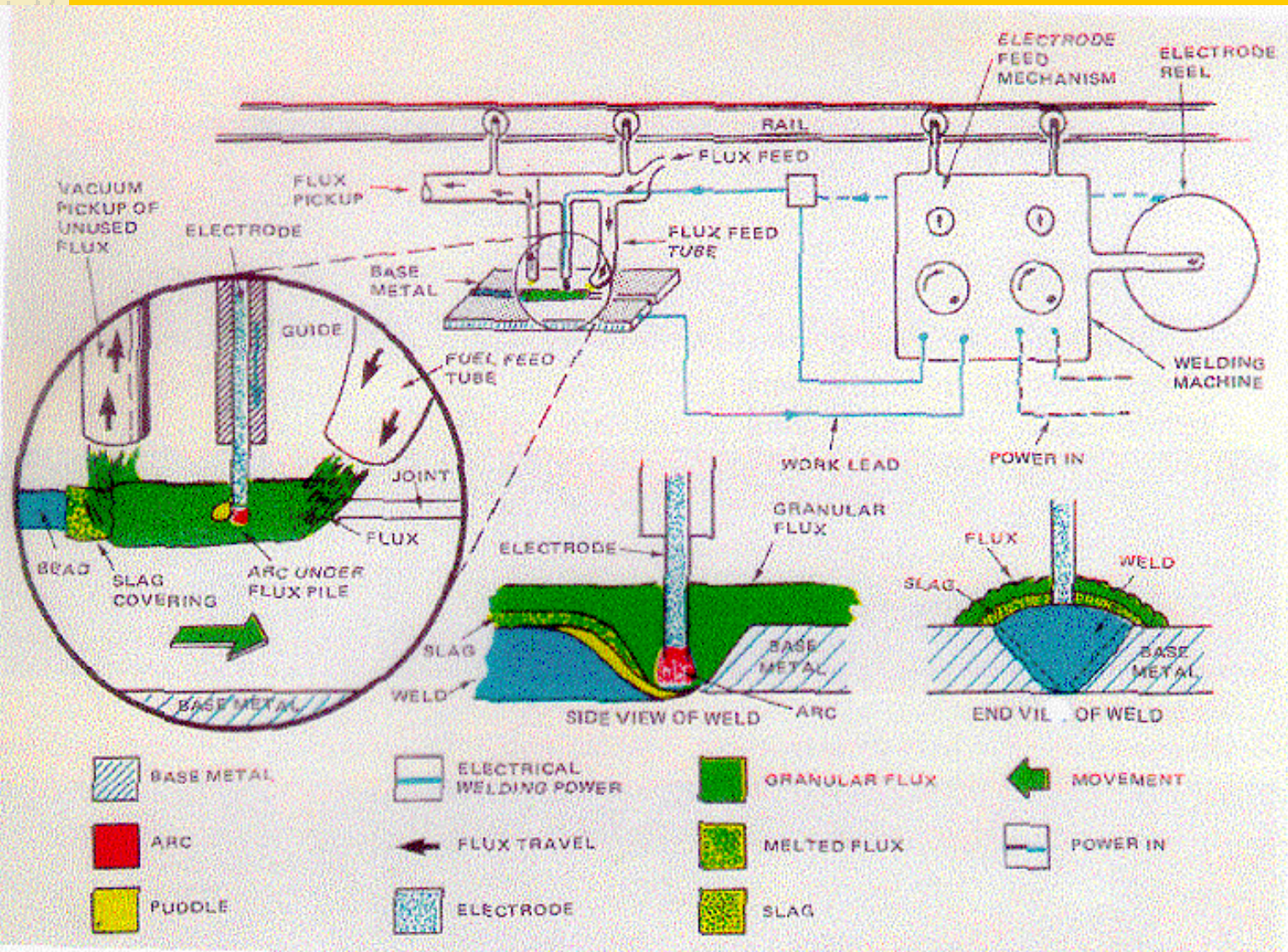

# Soldagem a Arco Submerso (SAS)

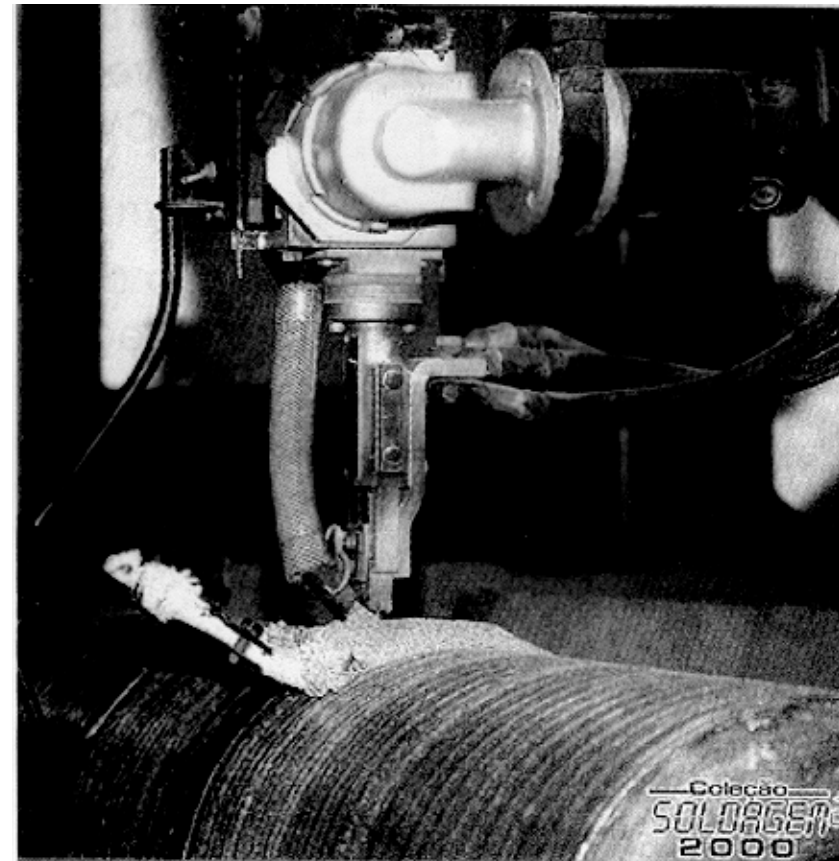
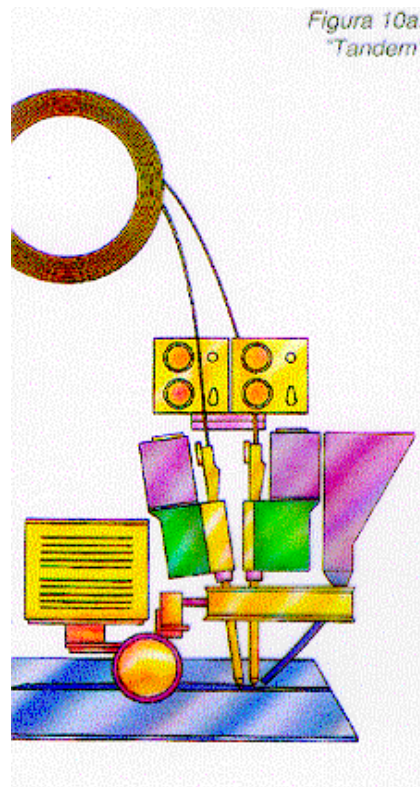

# Soldagem a Arco com Arame Tubular (SAT)

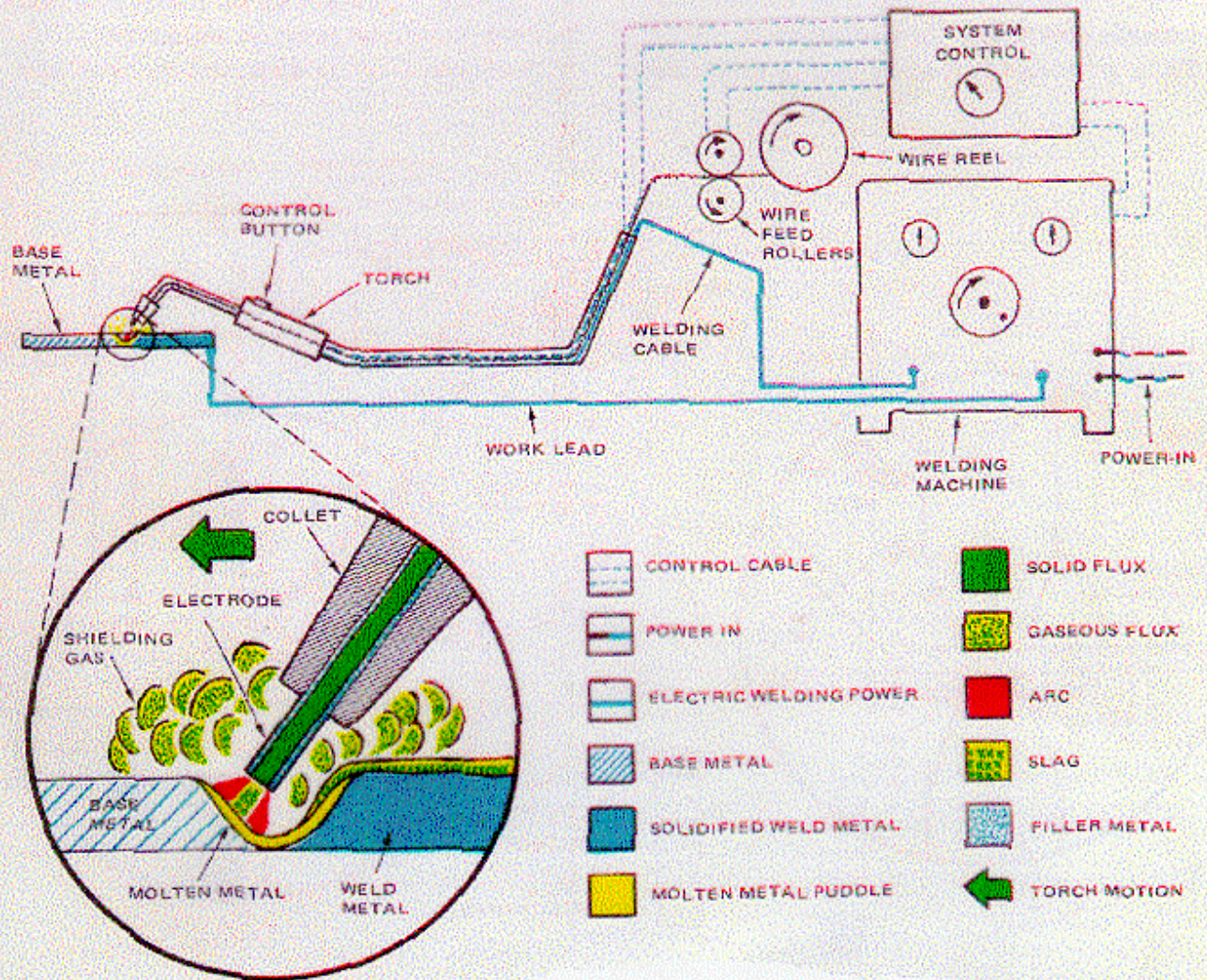

# Soldagem a Arco com Arame Tubular (SAT)

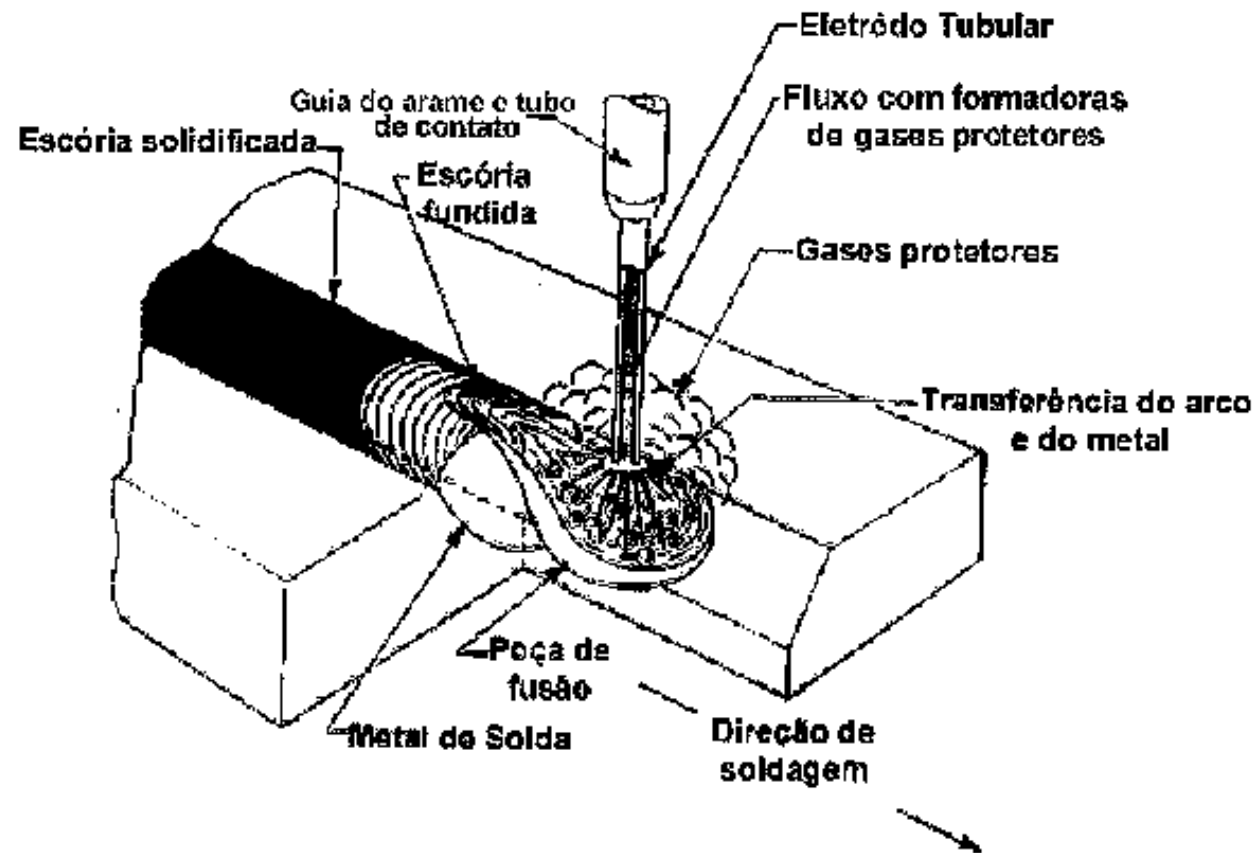

PROCESSO SAT AUTO-PROTEGIDO

# Soldagem a Arco com Arame Tubular (SAT)

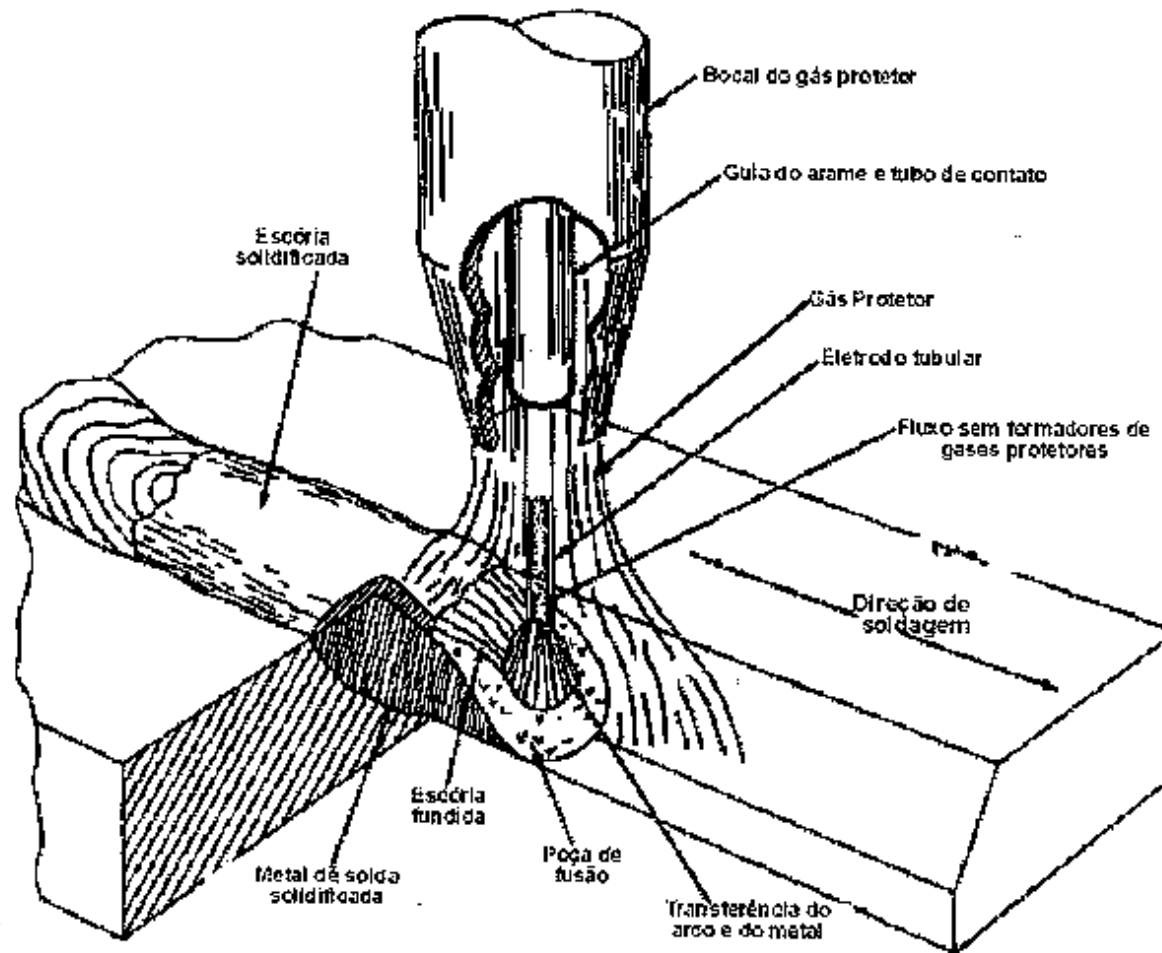

PROCESSO SAT COM PROTEÇÃO GASOSA

# Soldagem a Arco Tungstênio com Atmosfera Gasosa (SATG) ou TIG

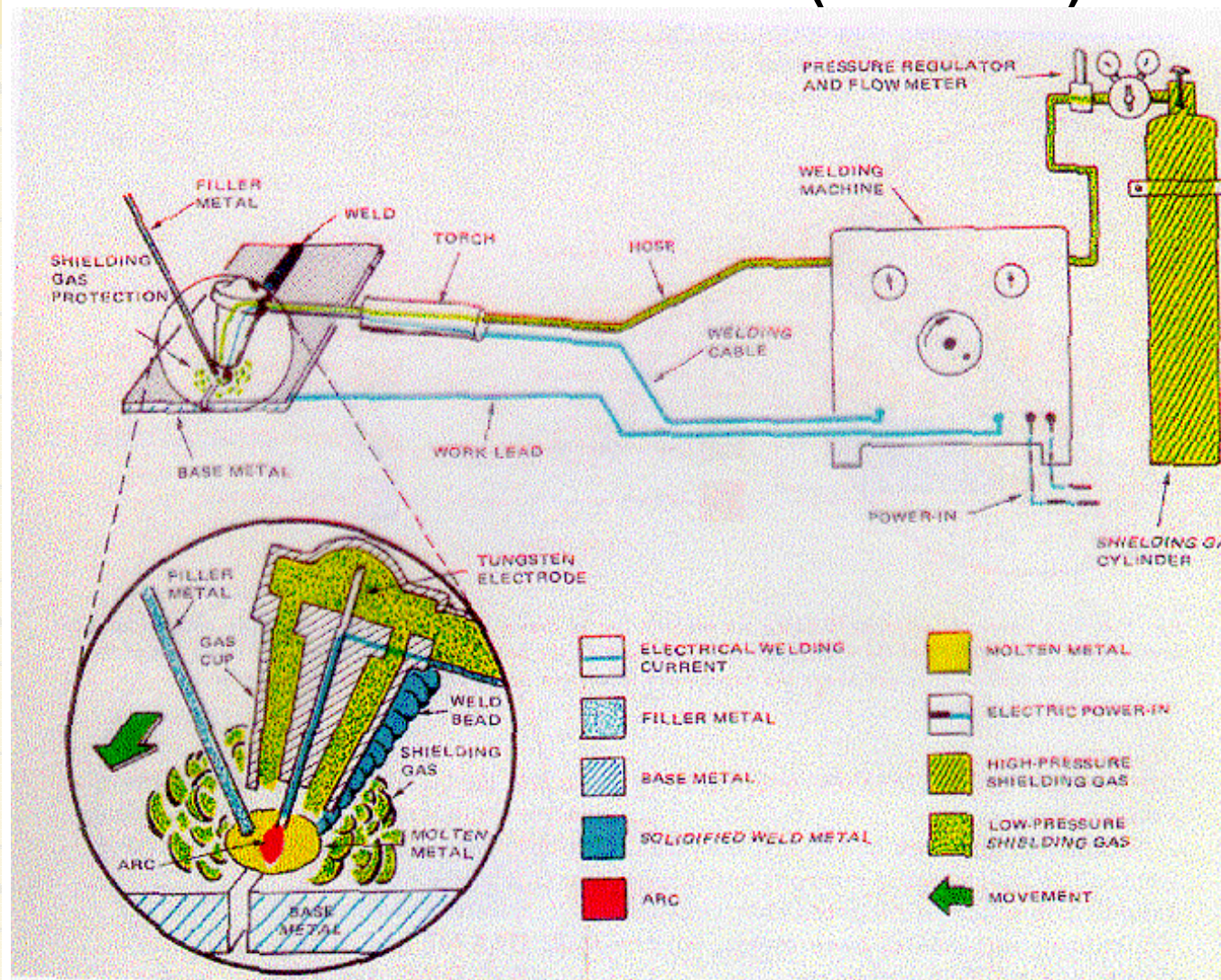



# ● Soldagem a Arco Tungstênio com Atmosfera Gasosa (SATG)

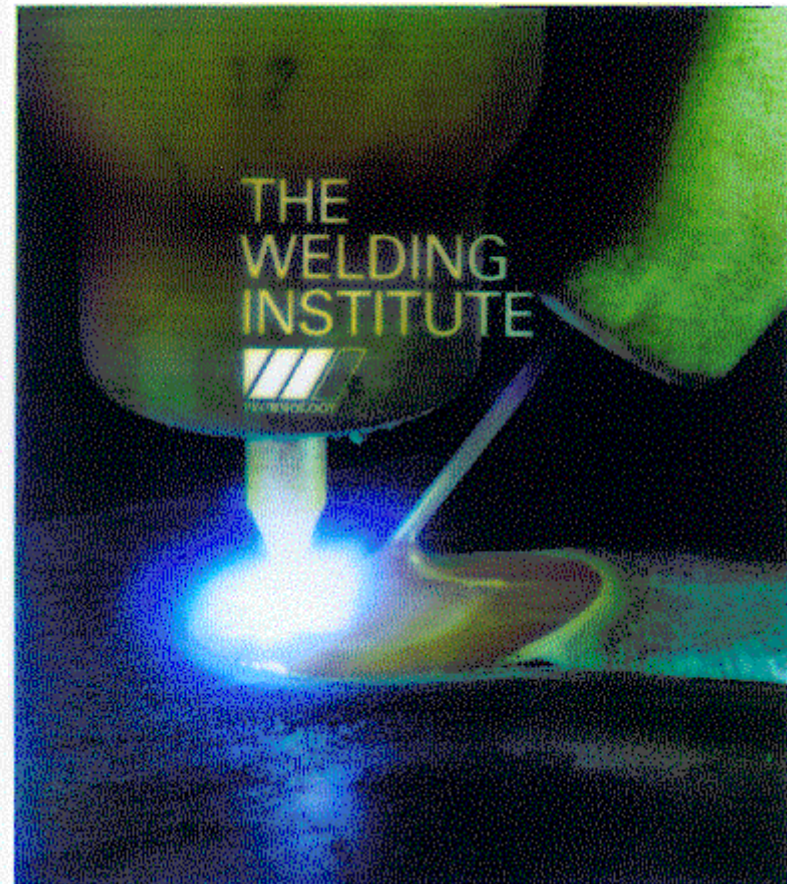
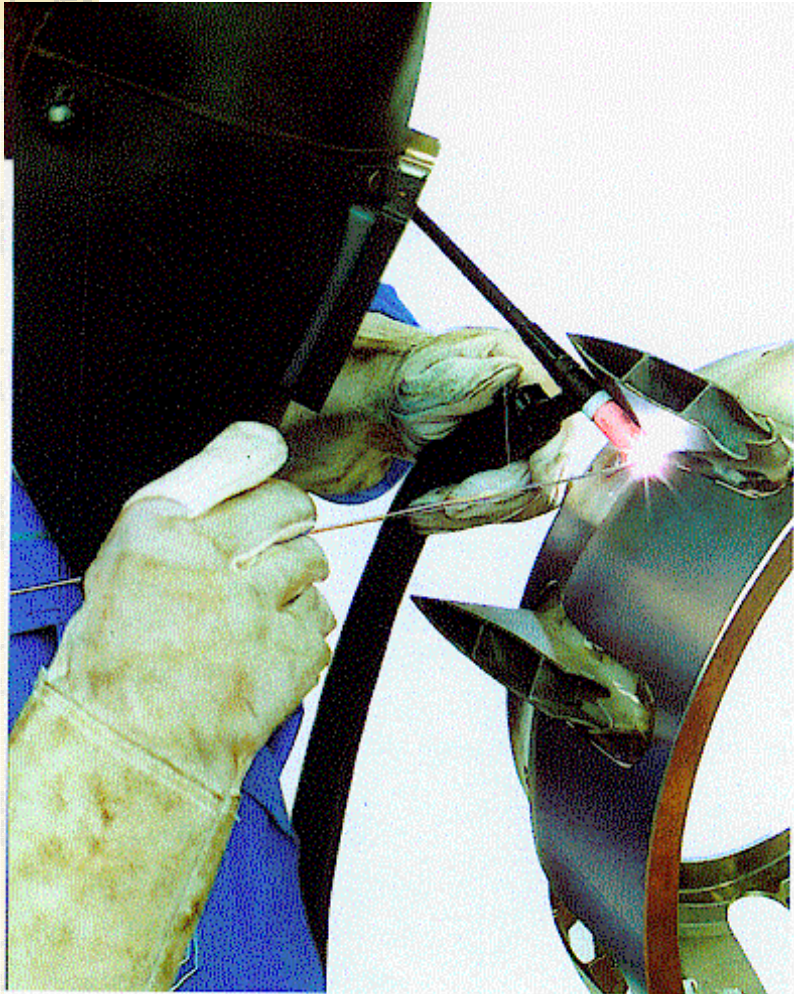

# SATG (polaridade)

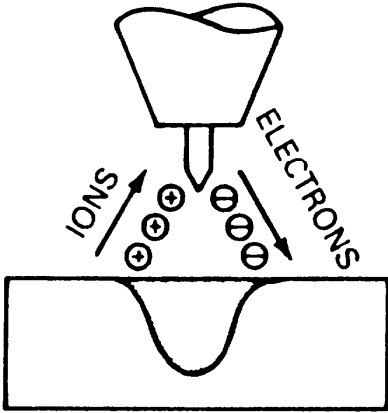
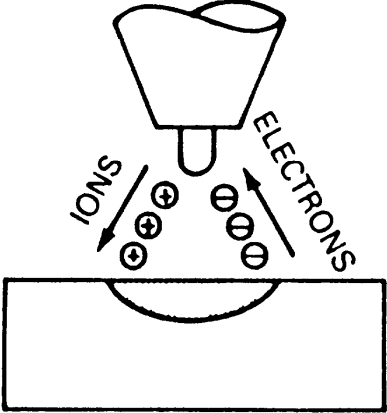
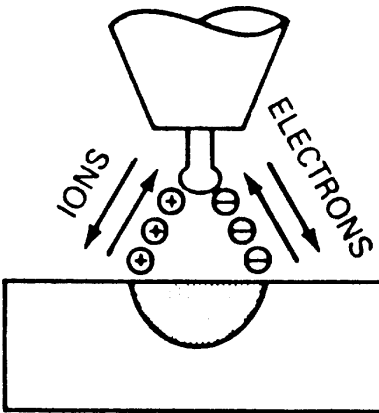
tipo de corrente	cc	cc	AC
polaridade do eletrodo	negativo	positivo	
fluxo dos eletrons e ions			
características da penetração			
balanço do calor	70% peça 30% eletrodo	30% peça 70% eletrodo	50% peça 50% eletrodo
penetração	profunda e estreita	raza e larga	média
polaridade dos eletrodos do arco elétrico			

# Soldagem a Arco Metálico com Atmosfera Gasosa (SAMG) ou MIG/MAG

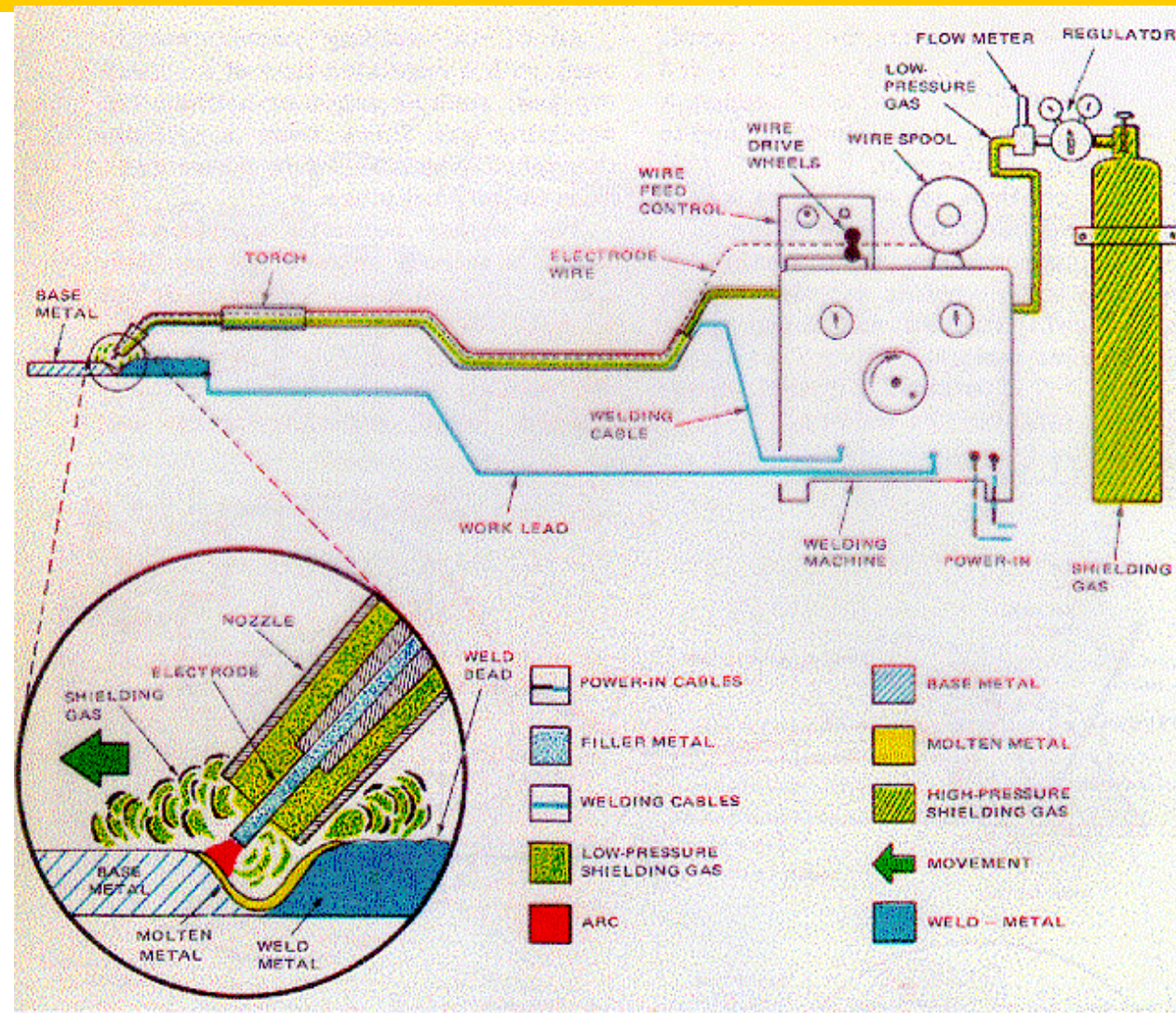

# Influência dos gases

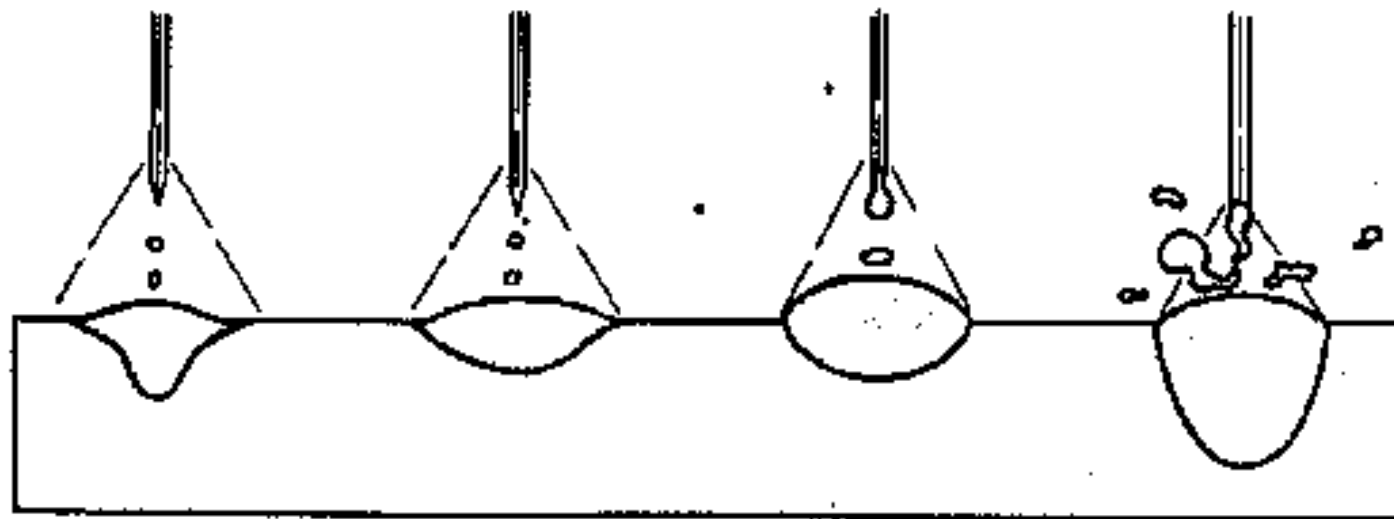

ARGON

ARGON-HELIUM

HELIUM

CO<sub>2</sub>

PROFUNDIDADE DE PENETRAÇÃO E FORMATO DO CORDÃO PARA DIFERENTES GASES

# Gás Ativo

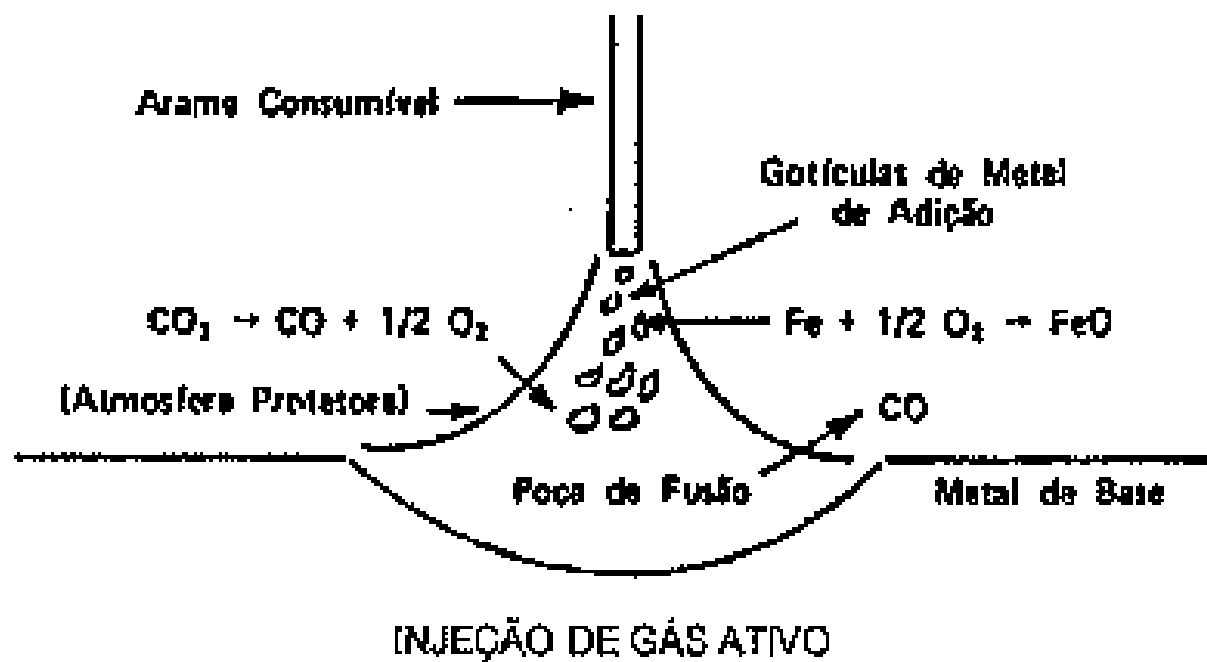

# ● Soldagem a Arco Metálico com Atmosfera Gasosa (SAMG)

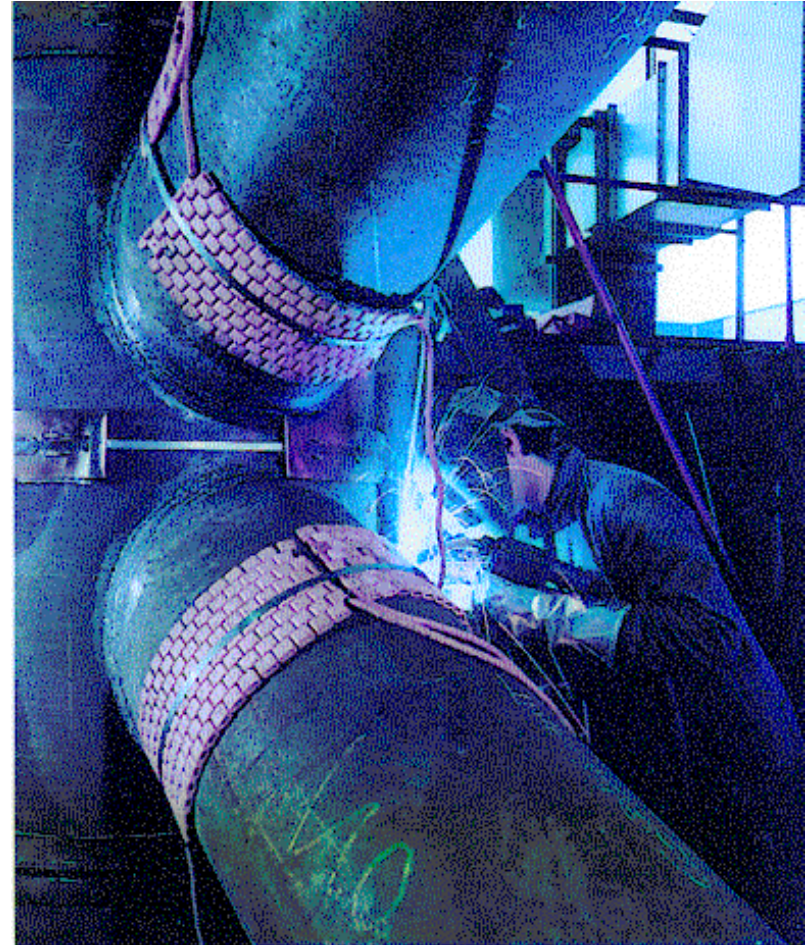
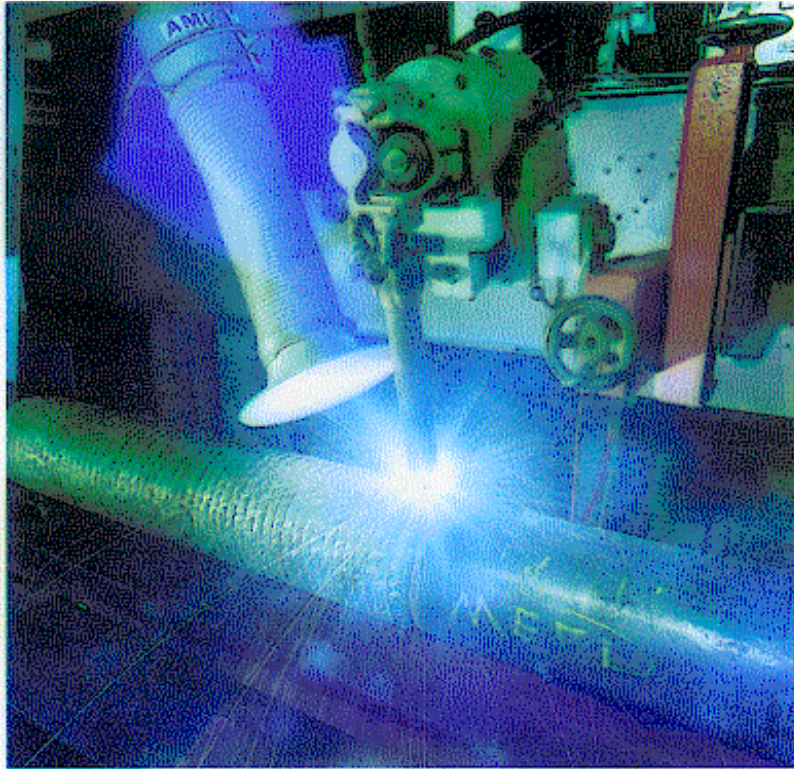

# Soldagem a Arco Plasma (SAP)

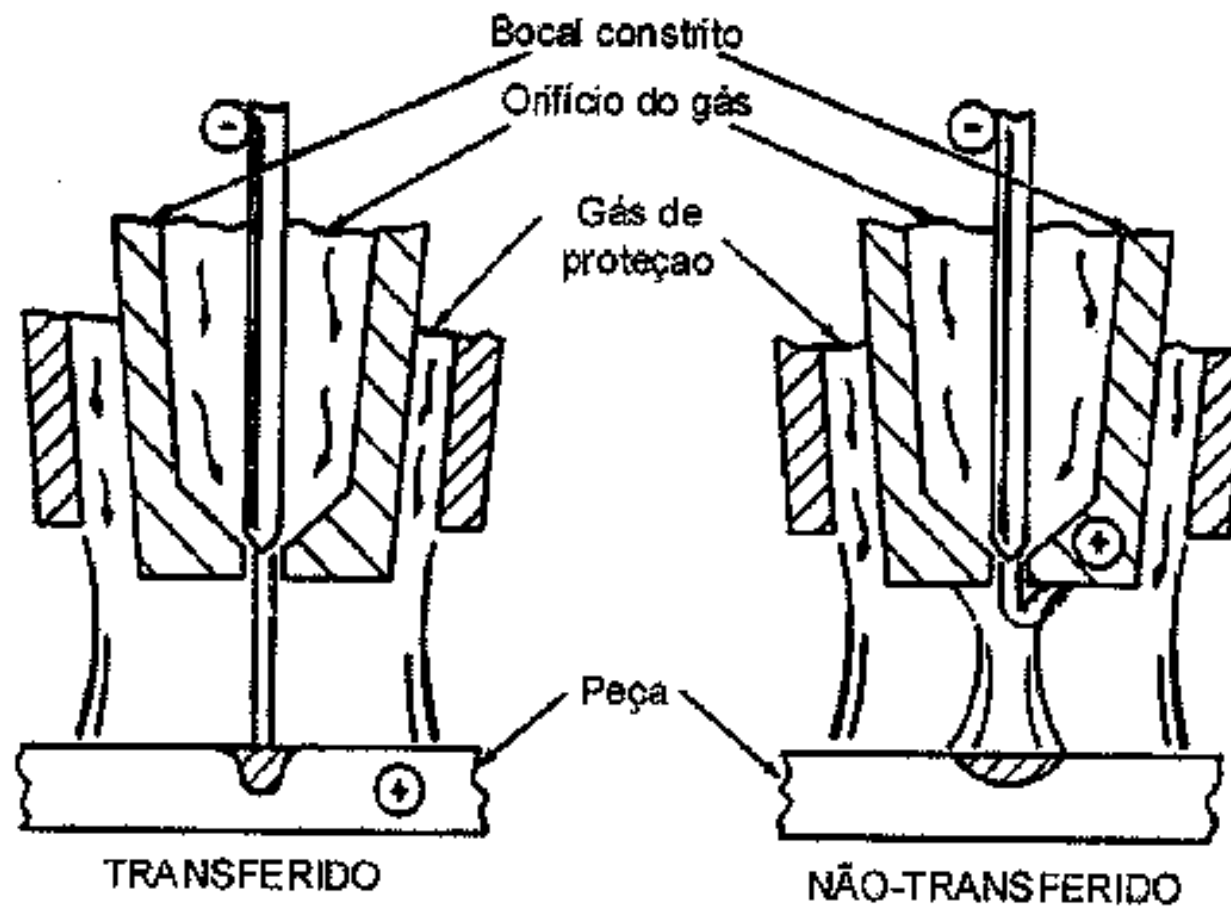

# Comparação SATG e SAP

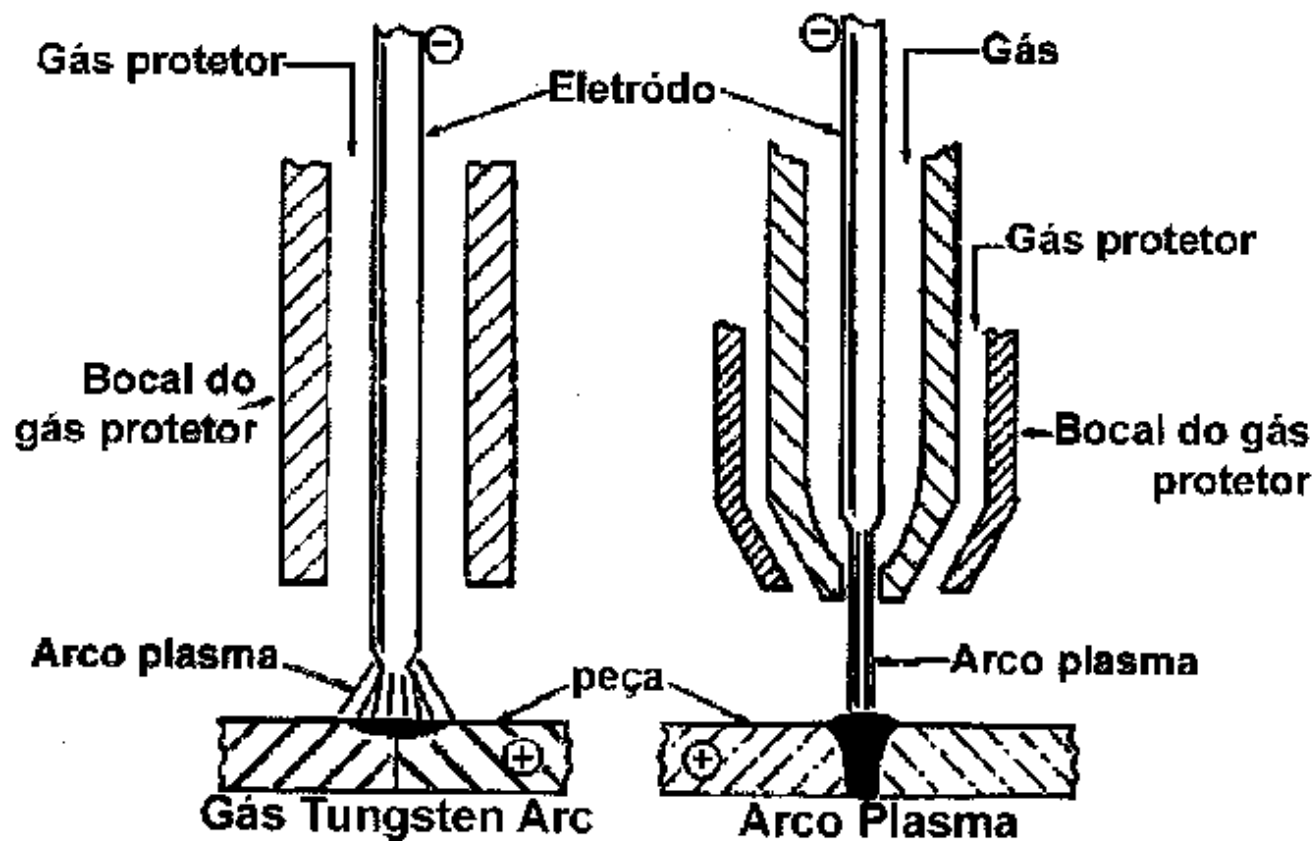

COMPARAÇÃO ENTRE OS PROCESSOS SATG E SAP



# Soldagem a Eletroescória e Eletrogás

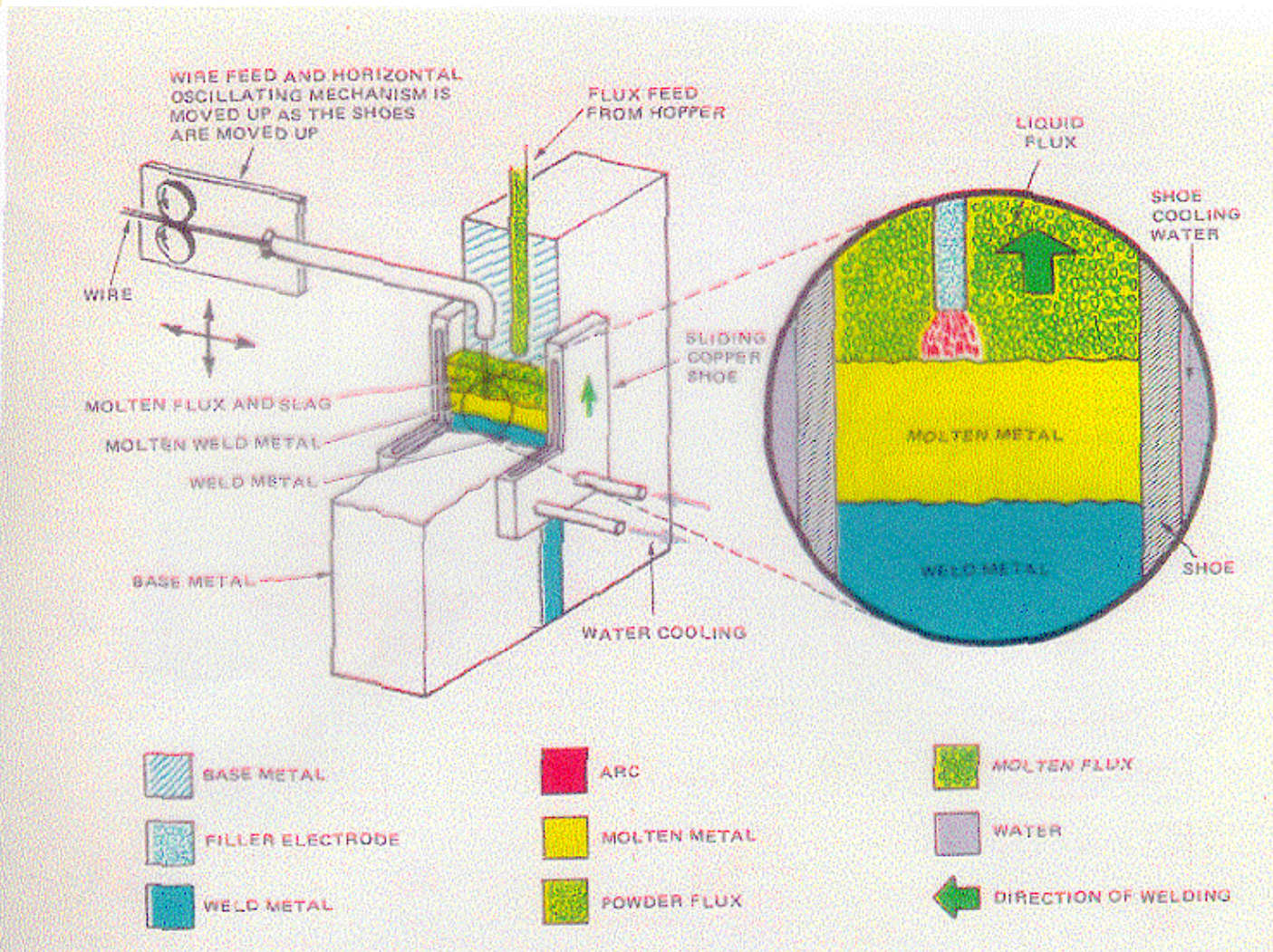

# Soldagem por Eletroescória ou por Eletrogás (SEE ou SEG)

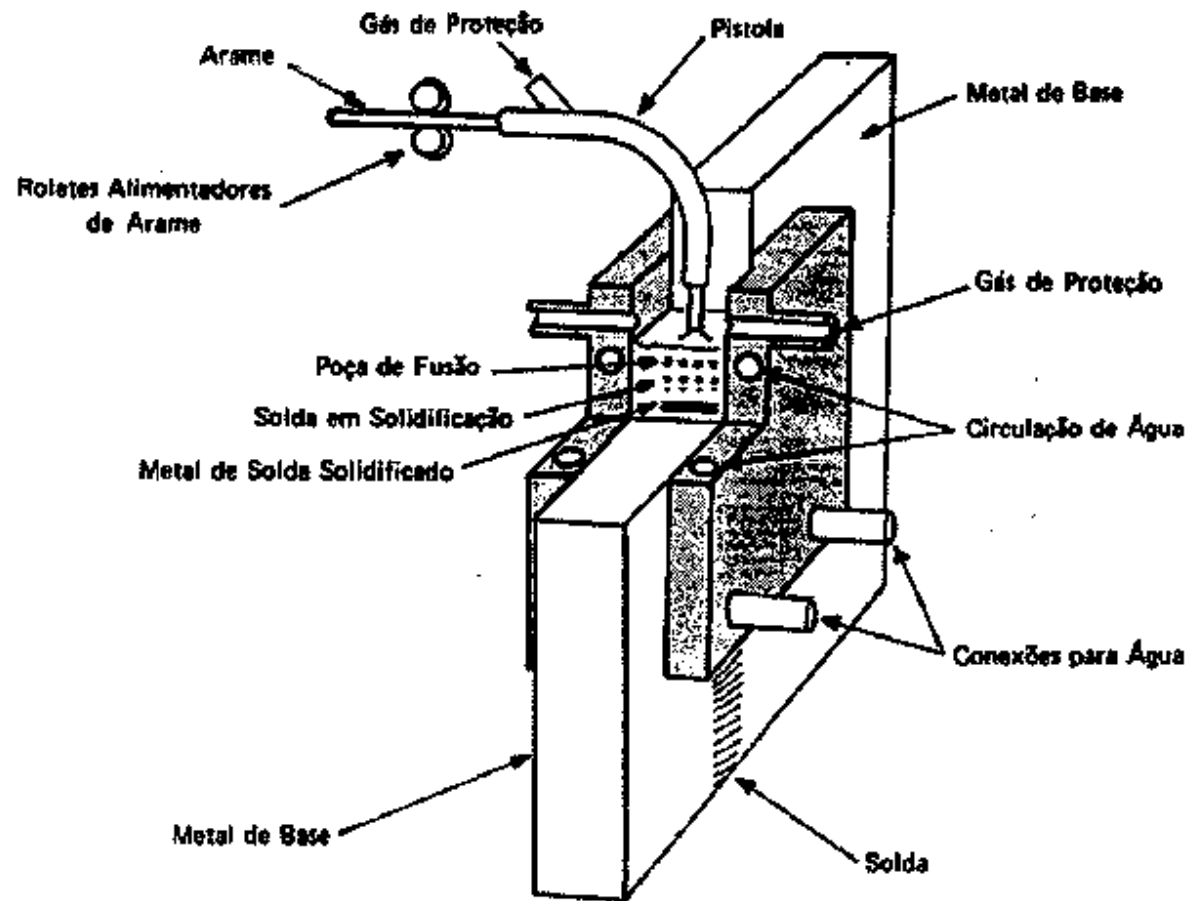

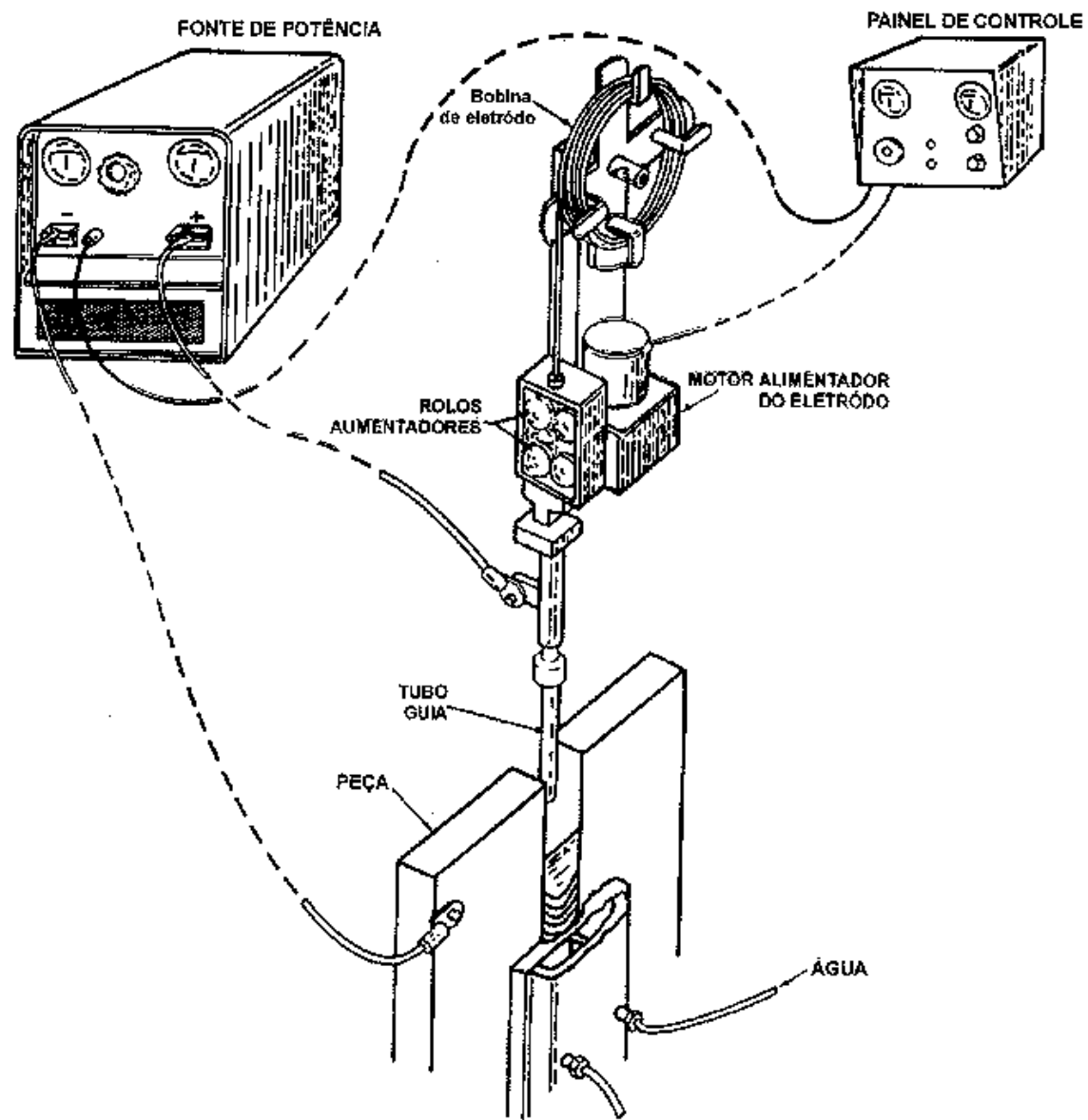

EQUIPAMENTO PARA SOLDAGEM SEG

# Soldagem por Resistência por Ponto (SRP)

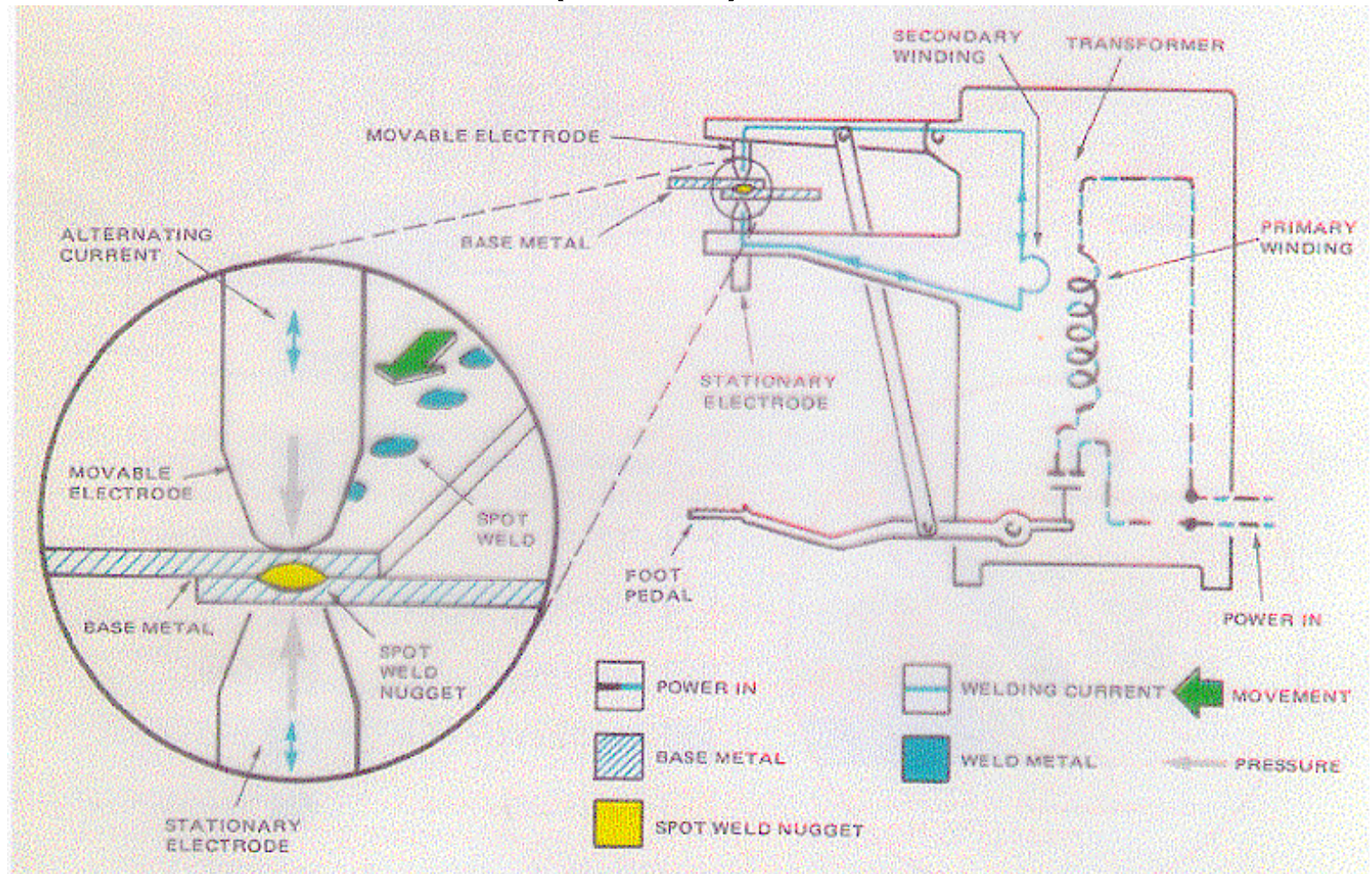

# Soldagem por Resistência por Costura (SRC)

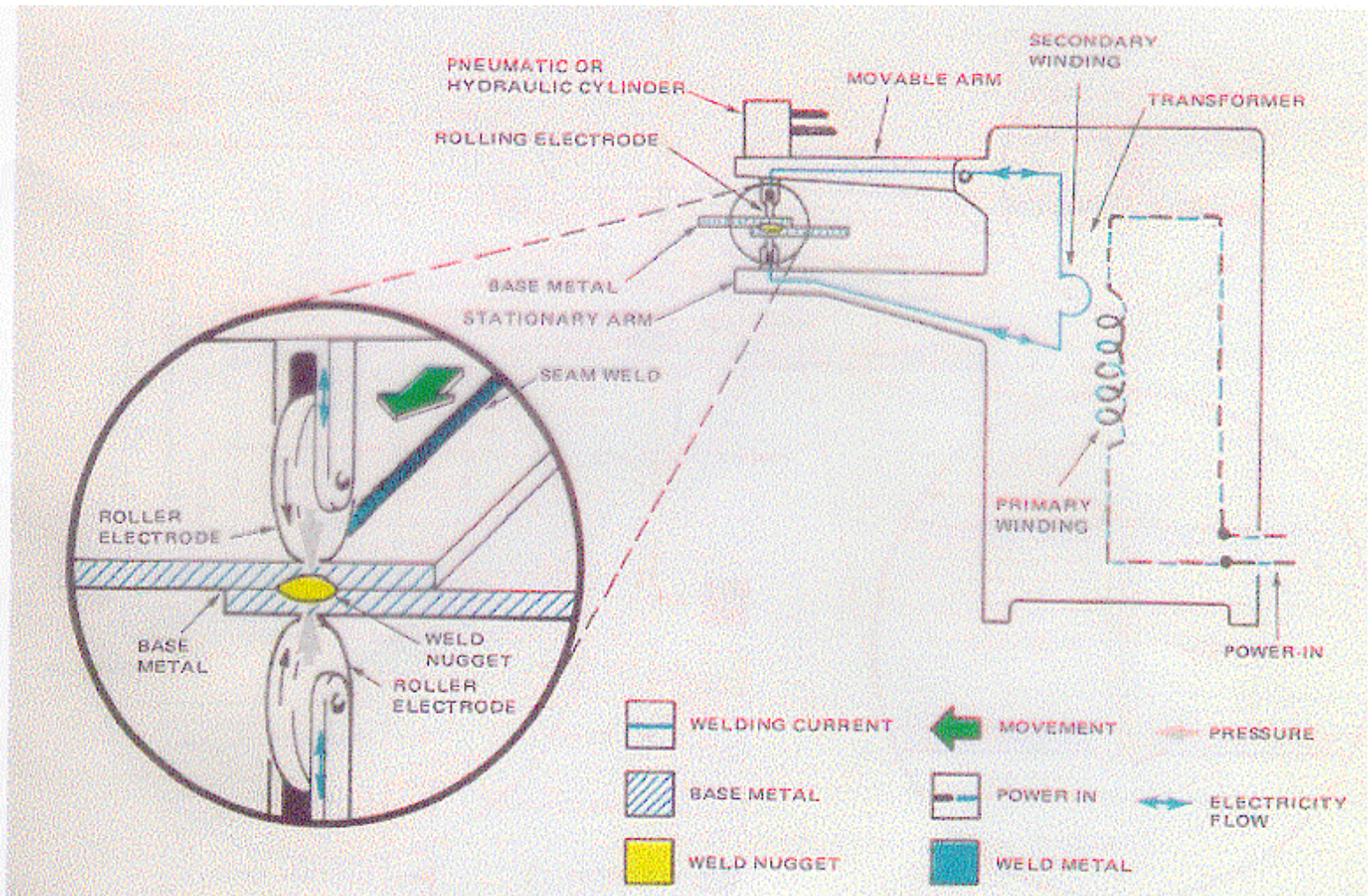

# SRP e SRC

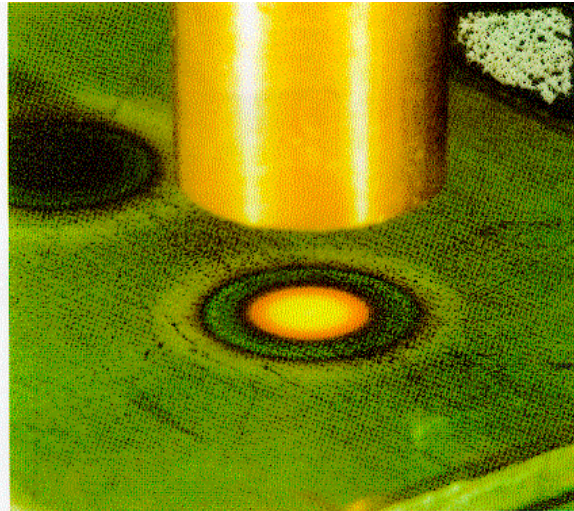

Soldagem por ponto logo após o levantamento do eletrôdo

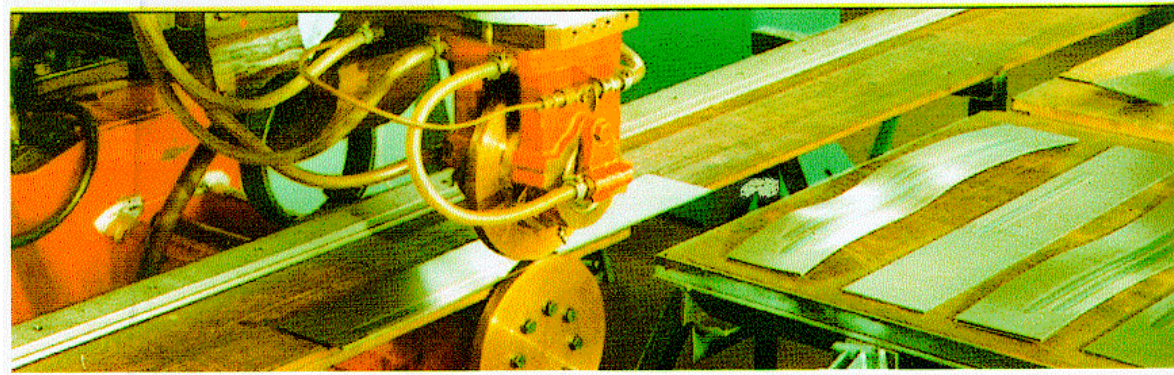

# Tipos de cordão

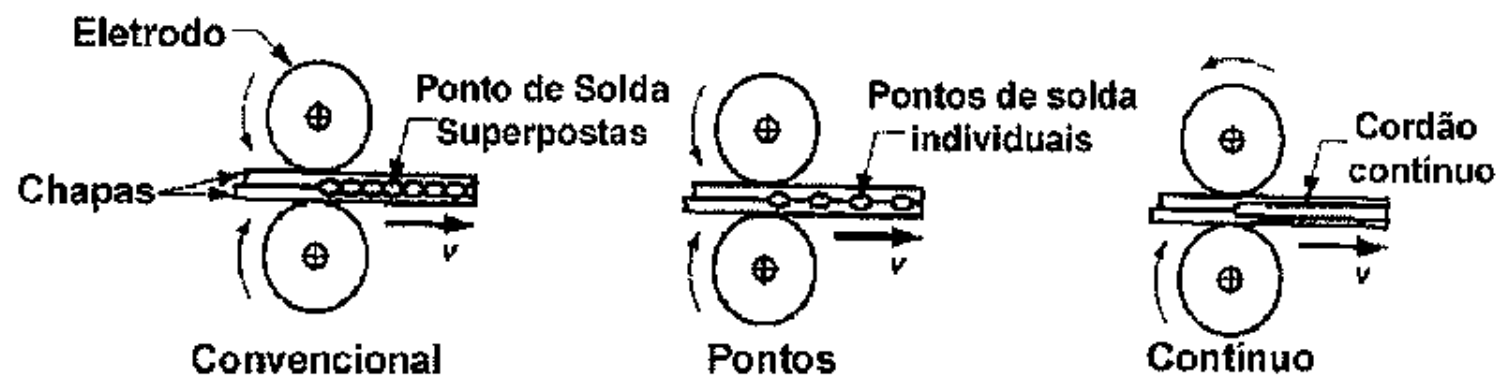

TIPOS DE CORDÕES DE SOLDA

# Soldagem por Resistência por Projeção (SRPR)

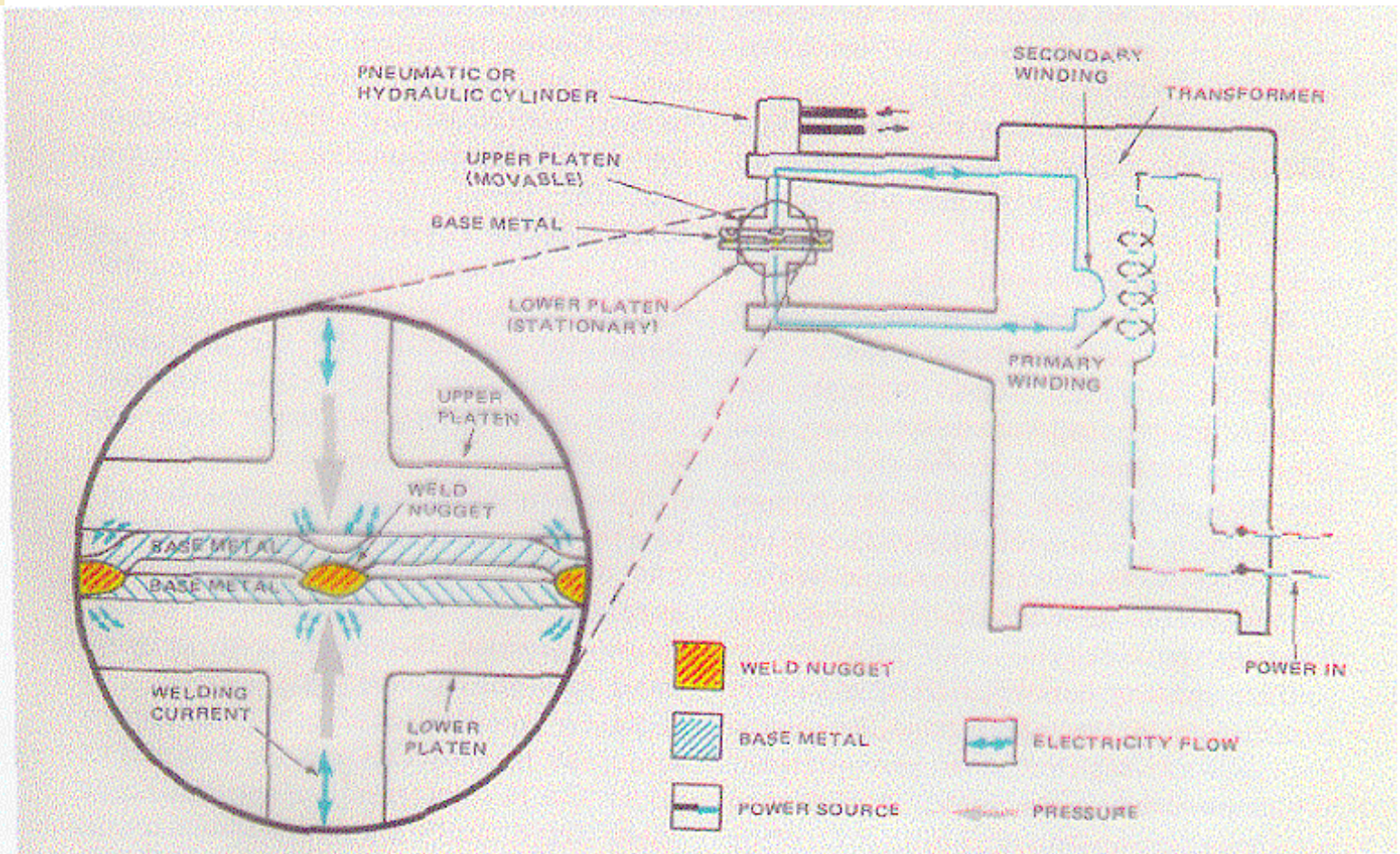



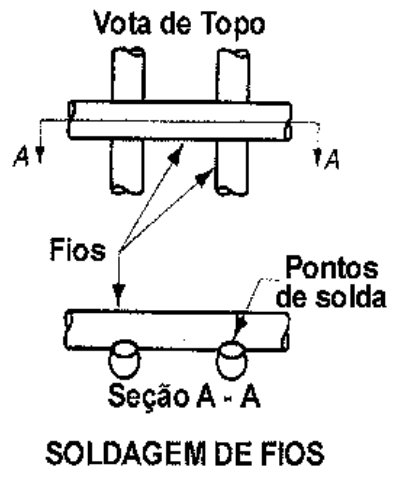
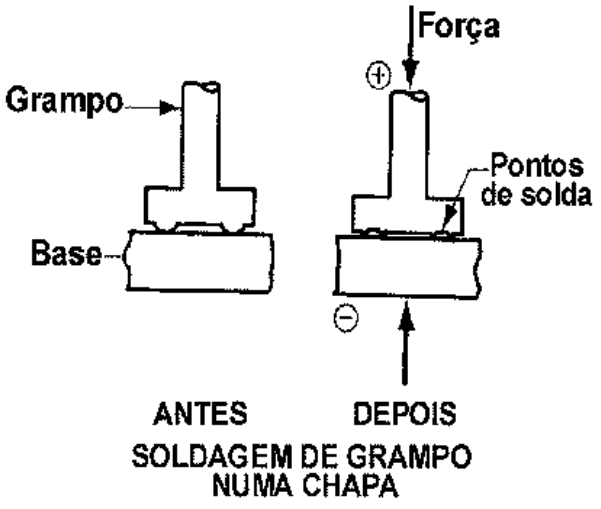
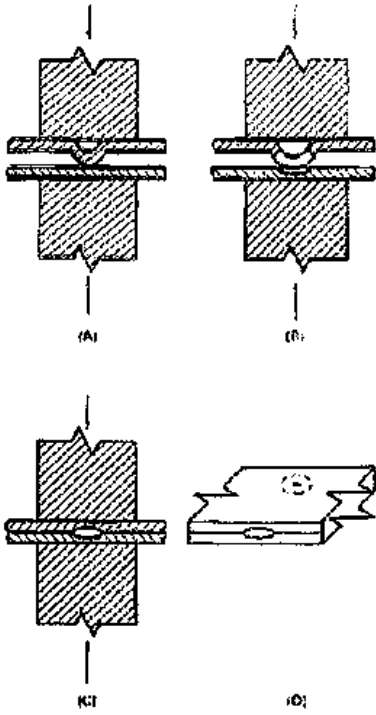
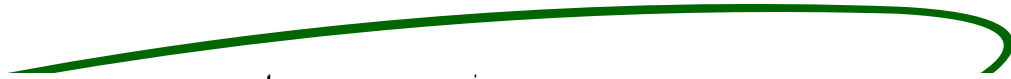

# Soldagem ao Arco por Centelhamento (SAC)

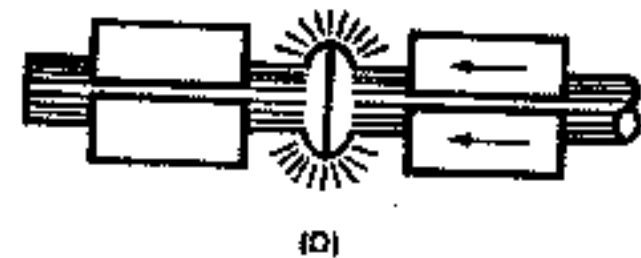
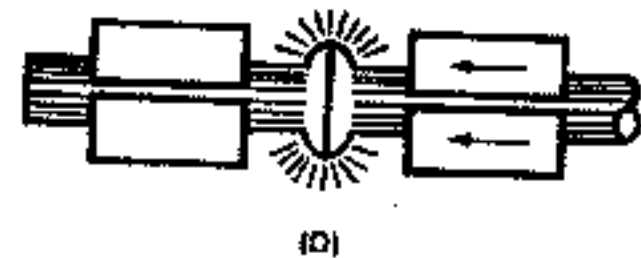
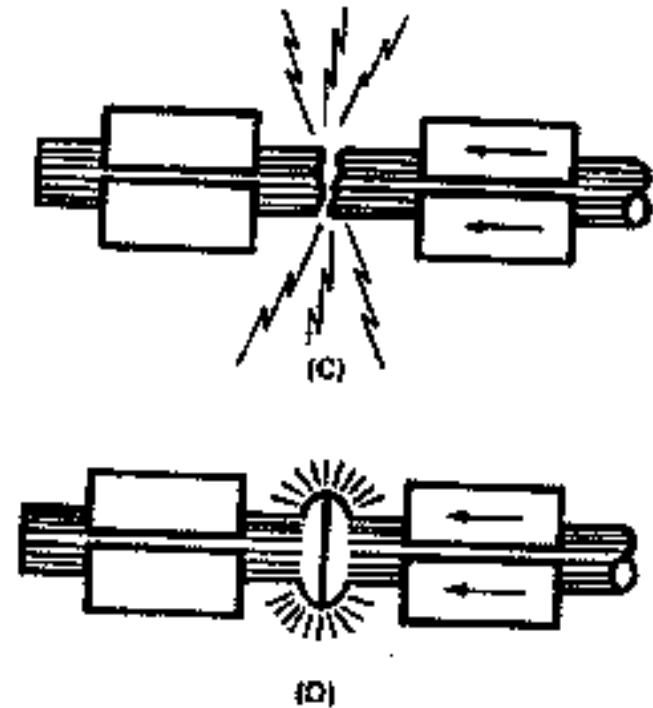
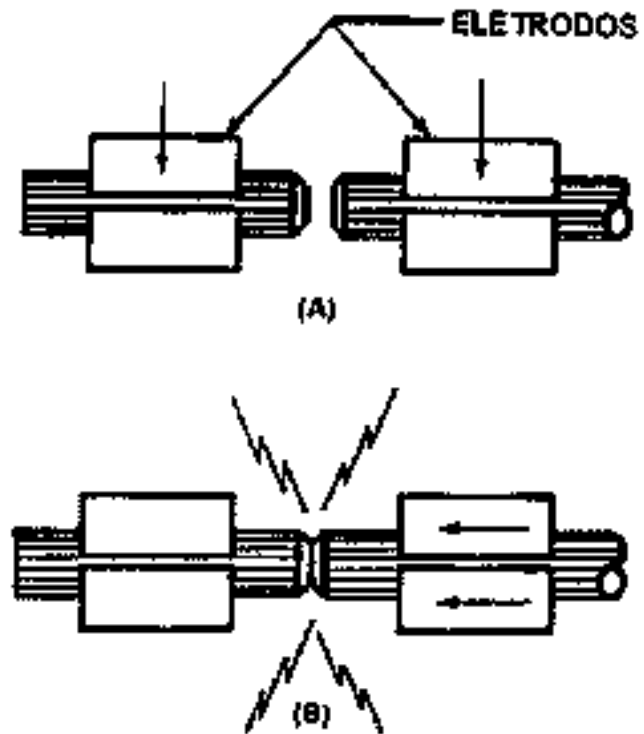

# Soldagem ao Arco por Centelhamento

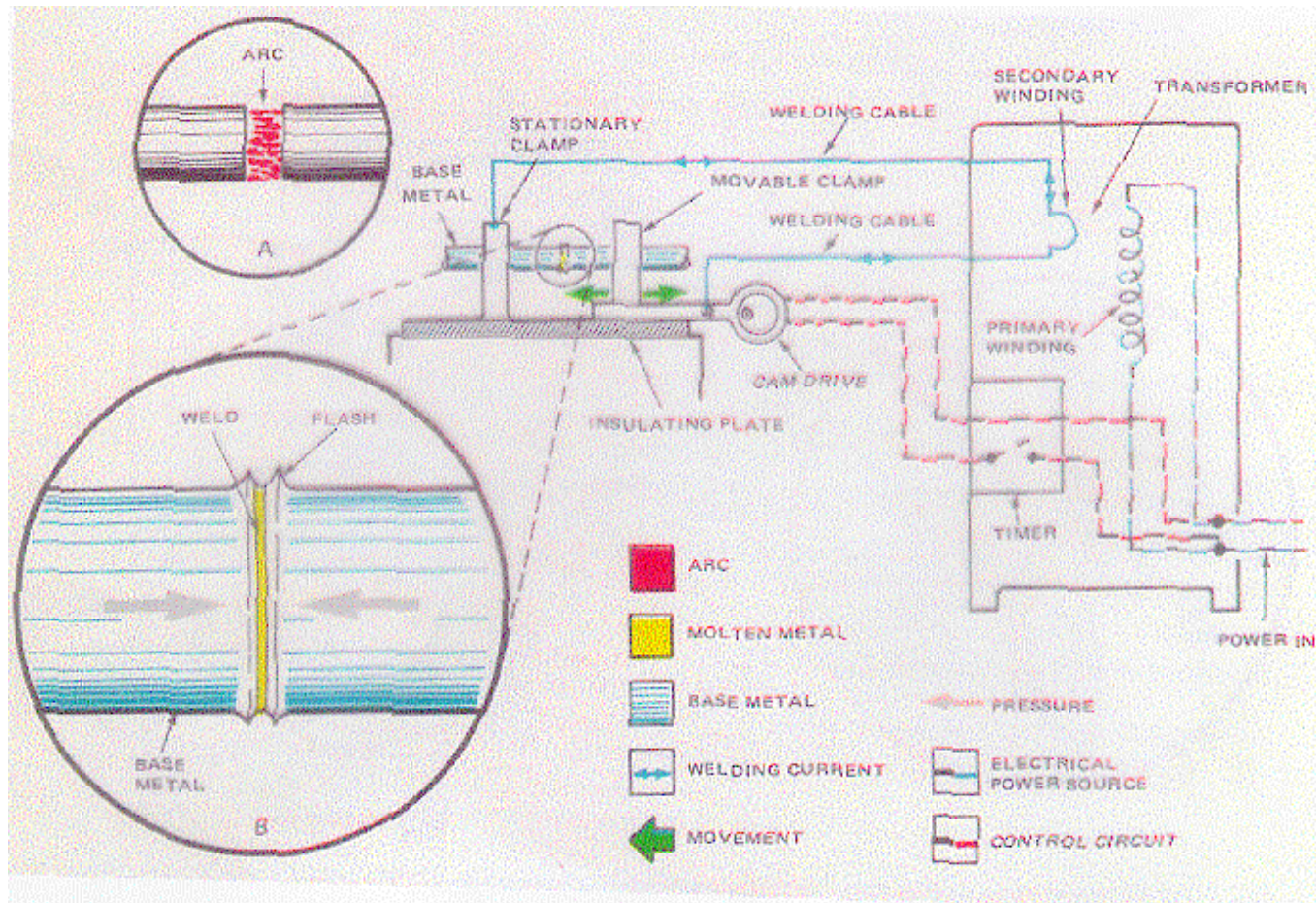

Processo de Soldagem a Arco por Centelhamento (SAC)

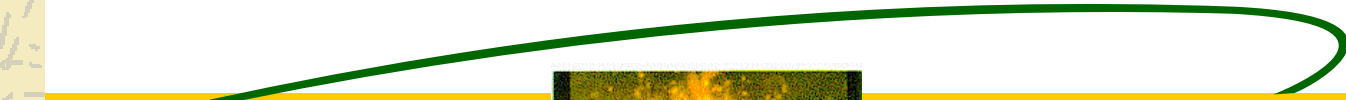
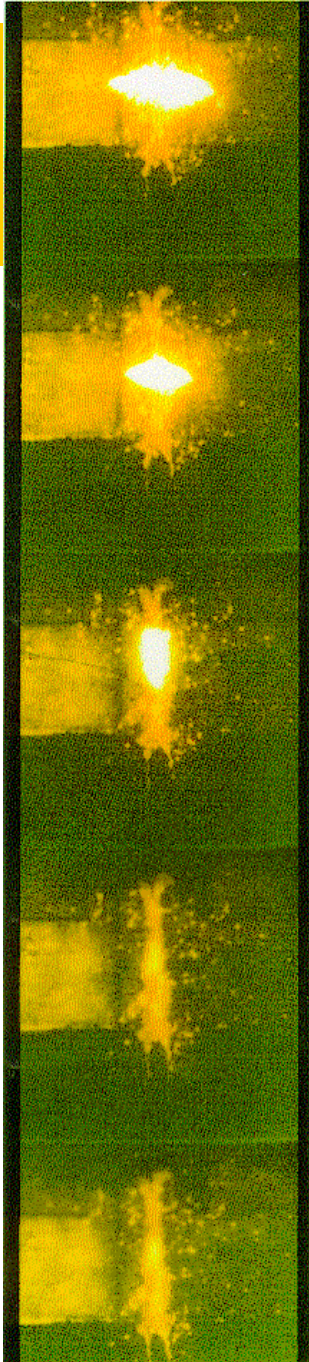

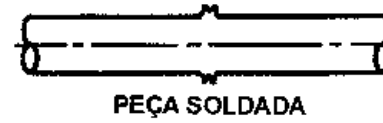
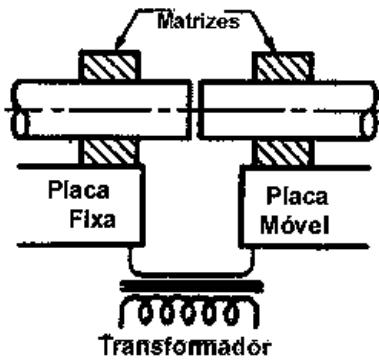

(A) SOLDAGEM ALINHADA

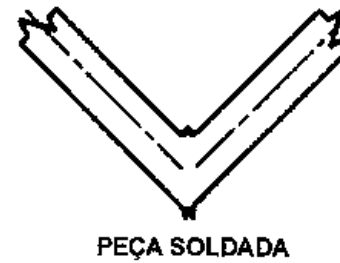
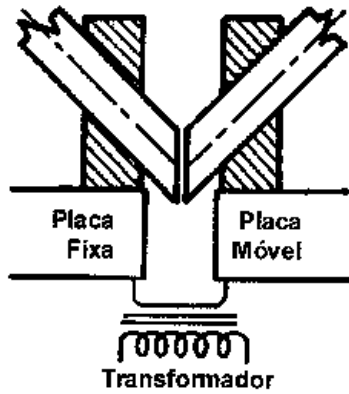

(B) SOLDAGEM DE ESQUADRIA

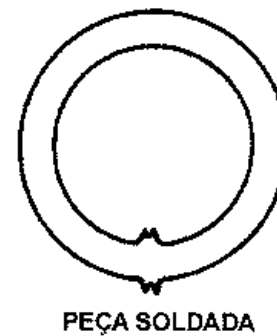
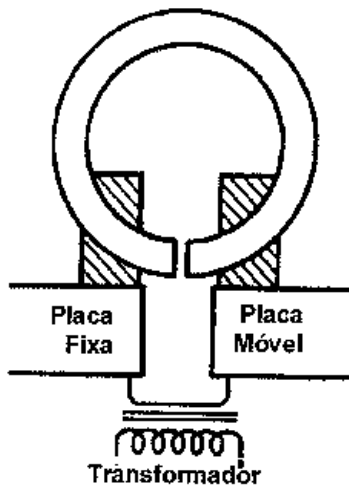

(C) SOLDAGEM DE ANEL

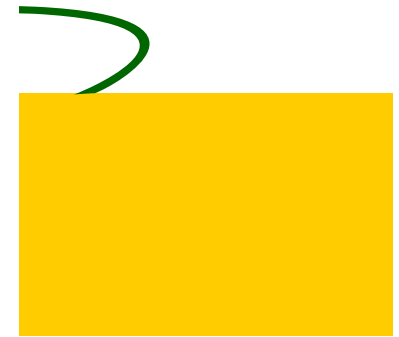

# Soldagem de Pinos (SP)

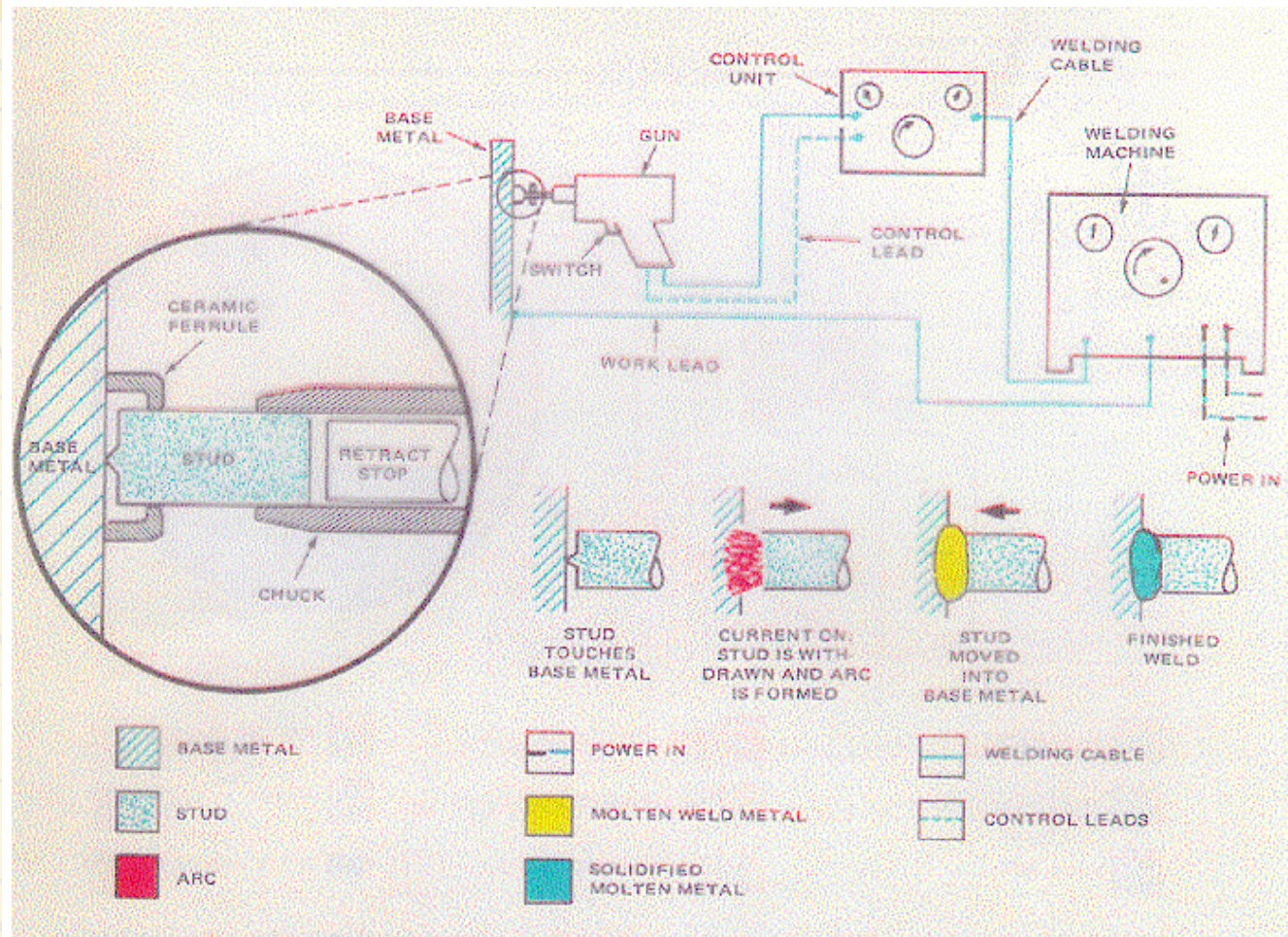

Processo de Soldagem de Pinos (SP)

# SOLDAGEM DE PINOS

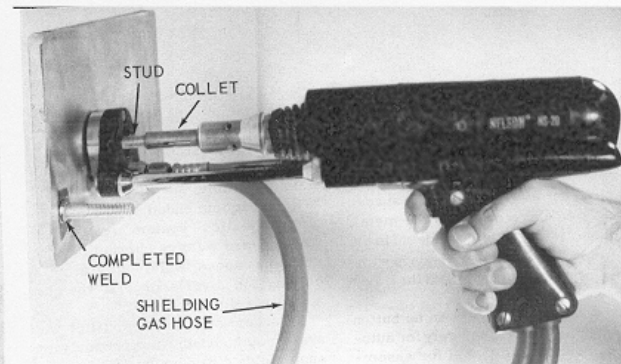
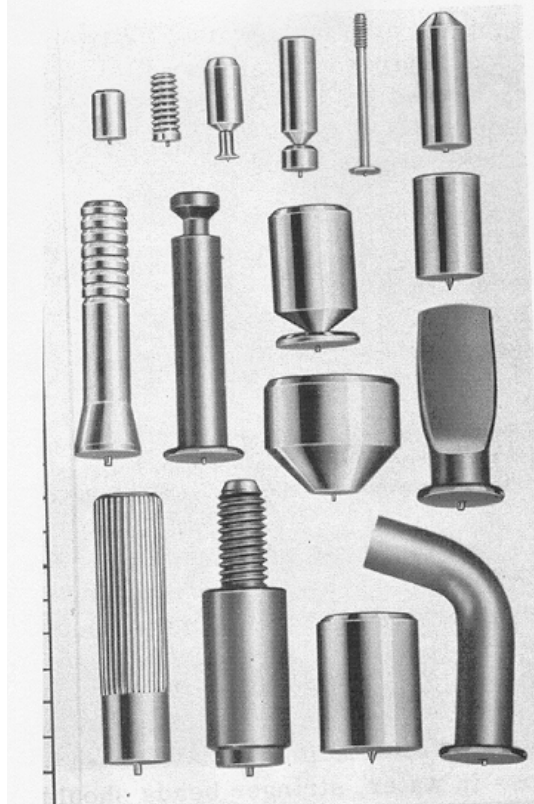
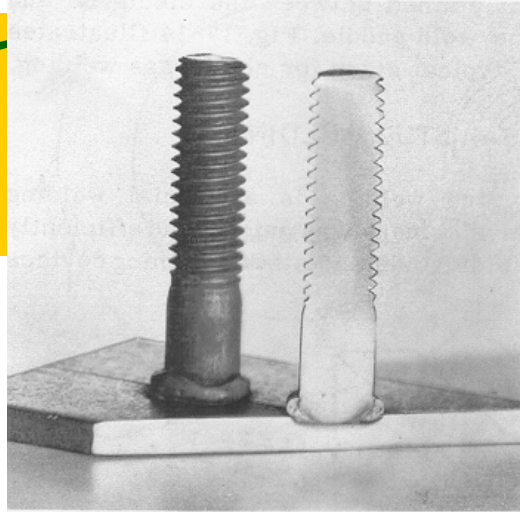

# Soldagem por Feixe de Elétrons (SFE)

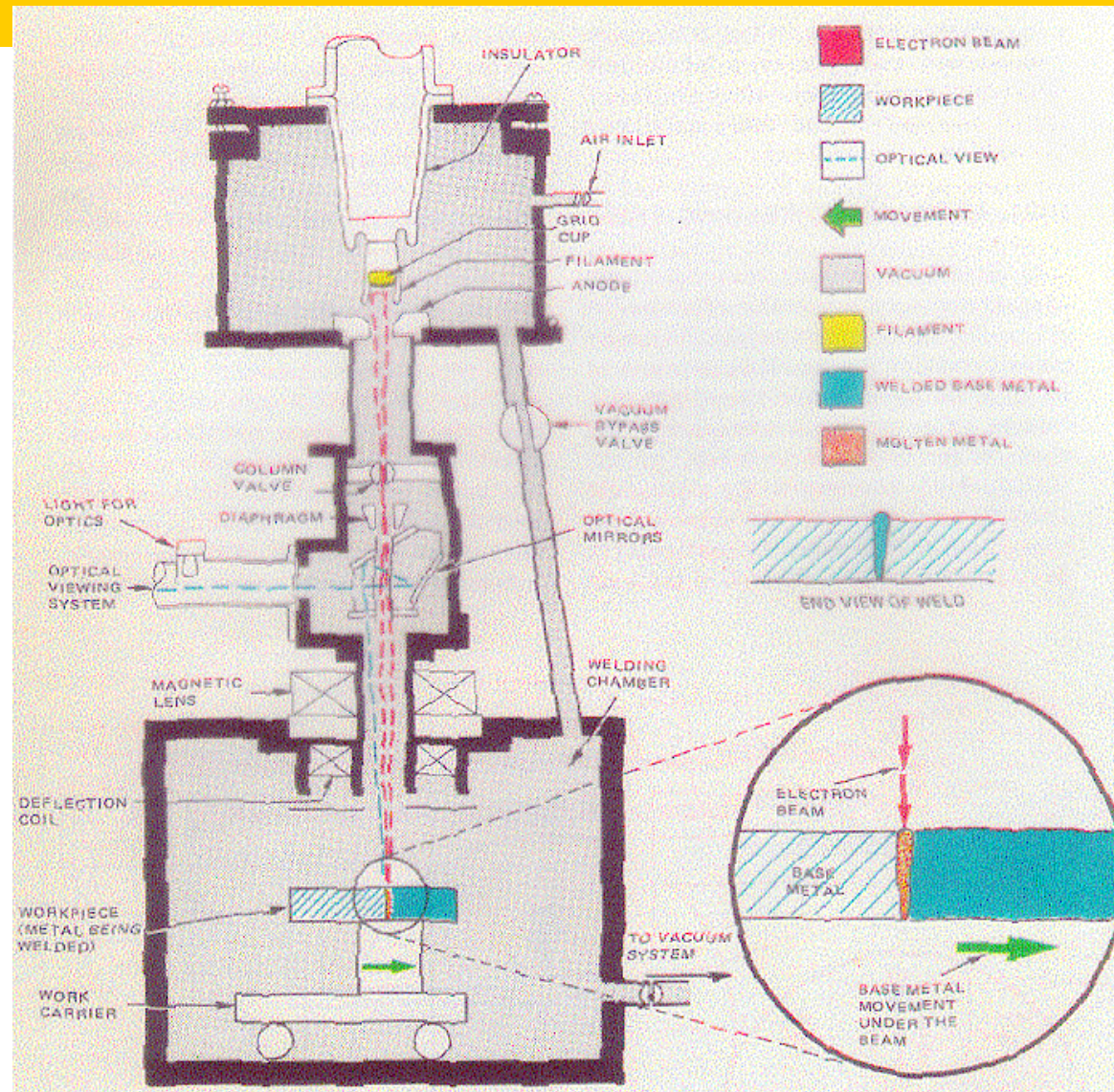



# Soldagem por Feixe de Elétrons

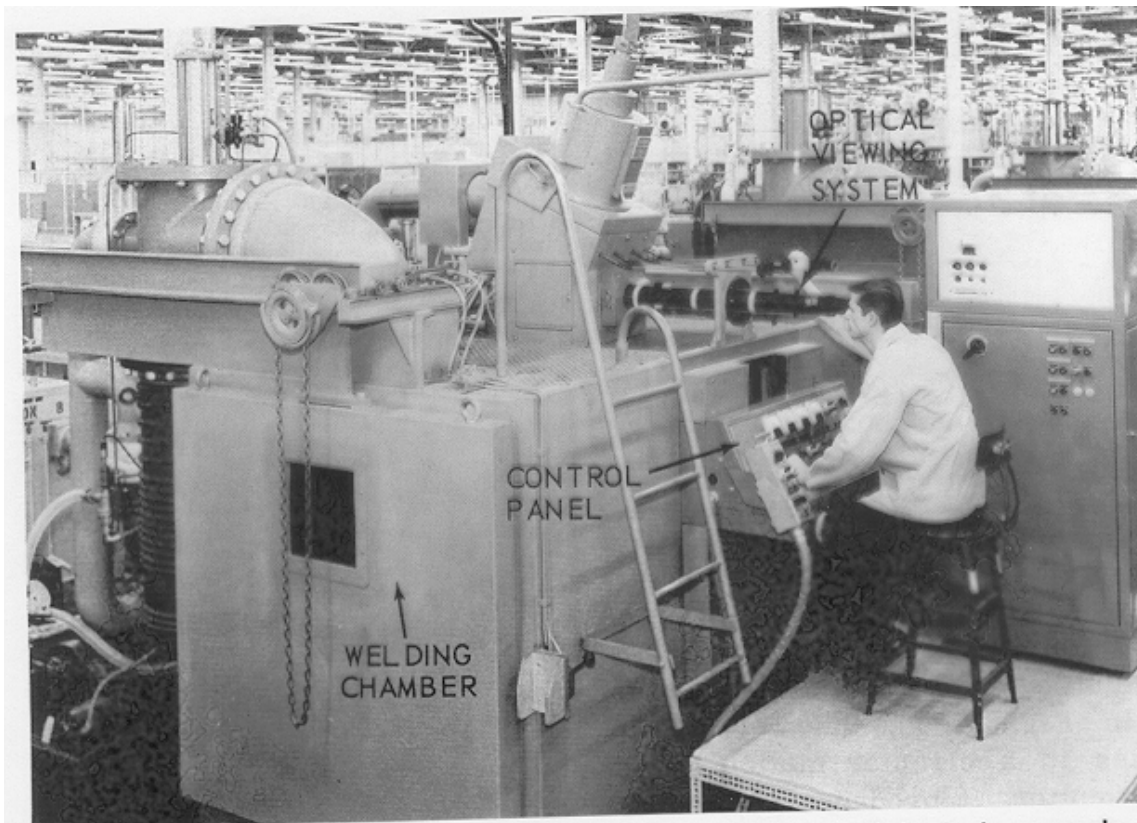

Complete electron beam welding machine. The weld is being made within an enclosed chamber. The operator views the weld through a special optical system. (Hamilton Standard Div., United Aircraft Corp.)

# Soldagem por Feixe de Elétron

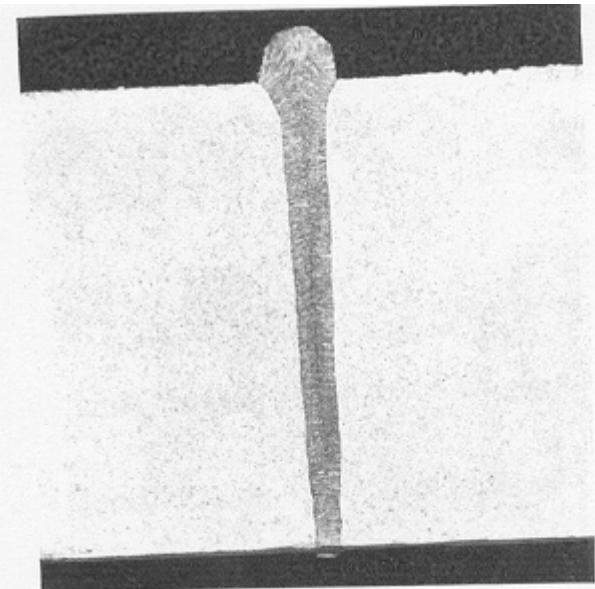
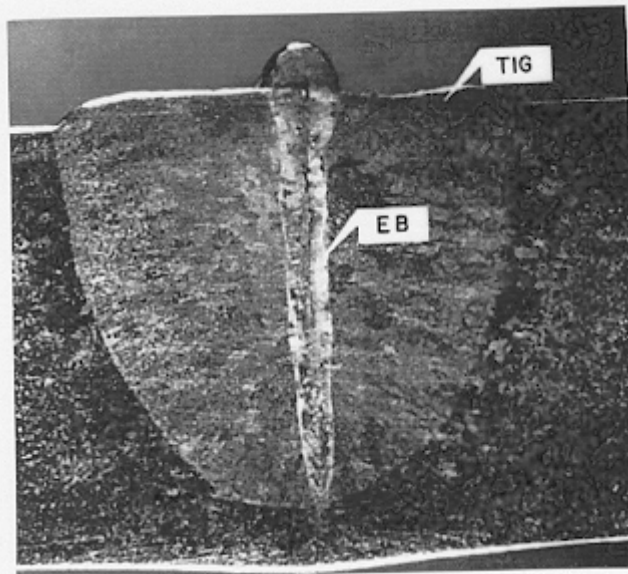

Material: aço

# Soldagem por LASER (SL)

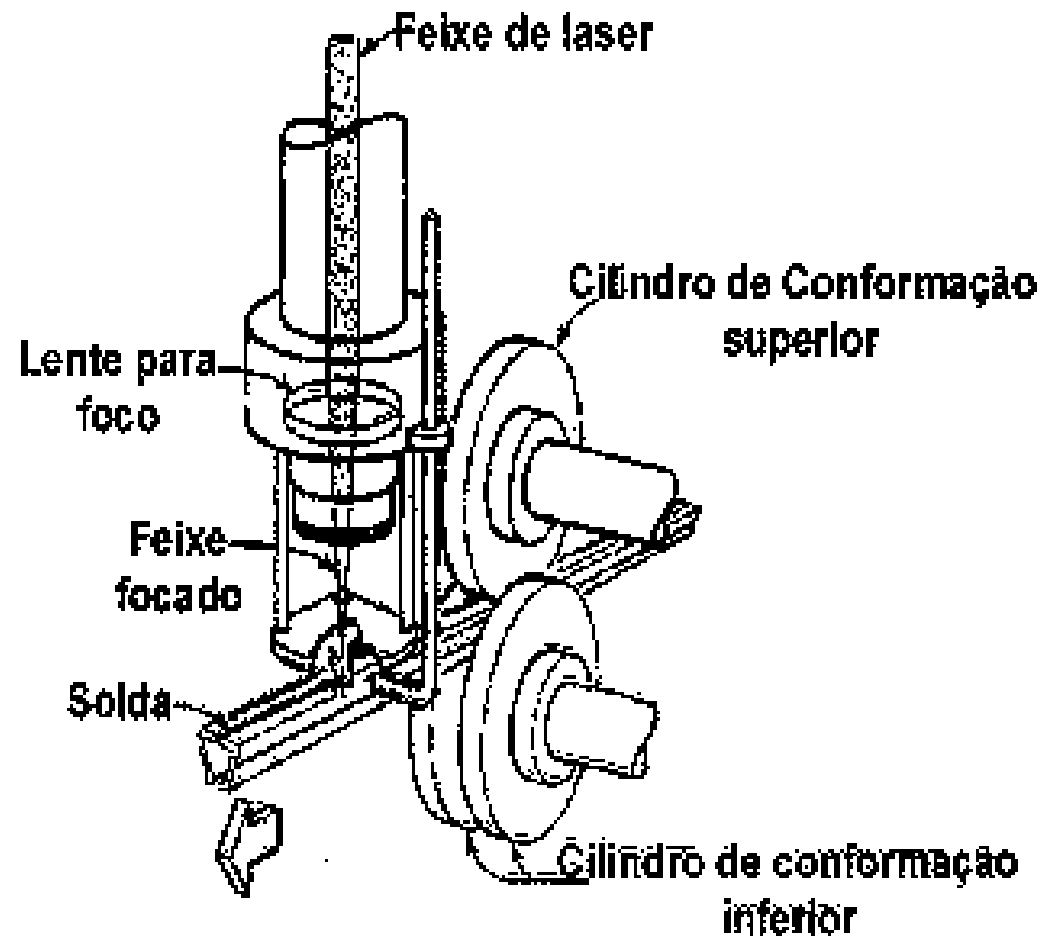

# Fontes de LASER

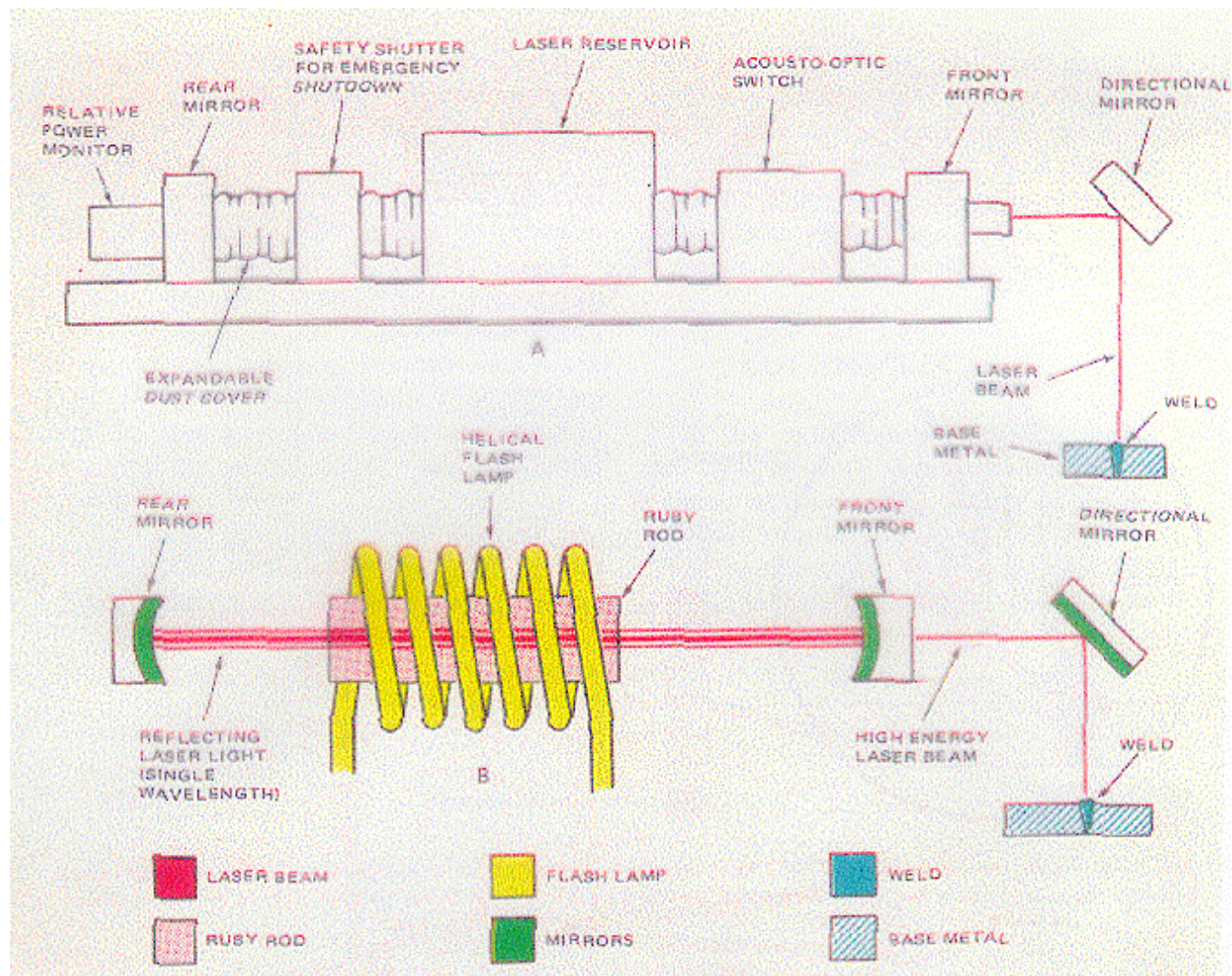

# Penetração

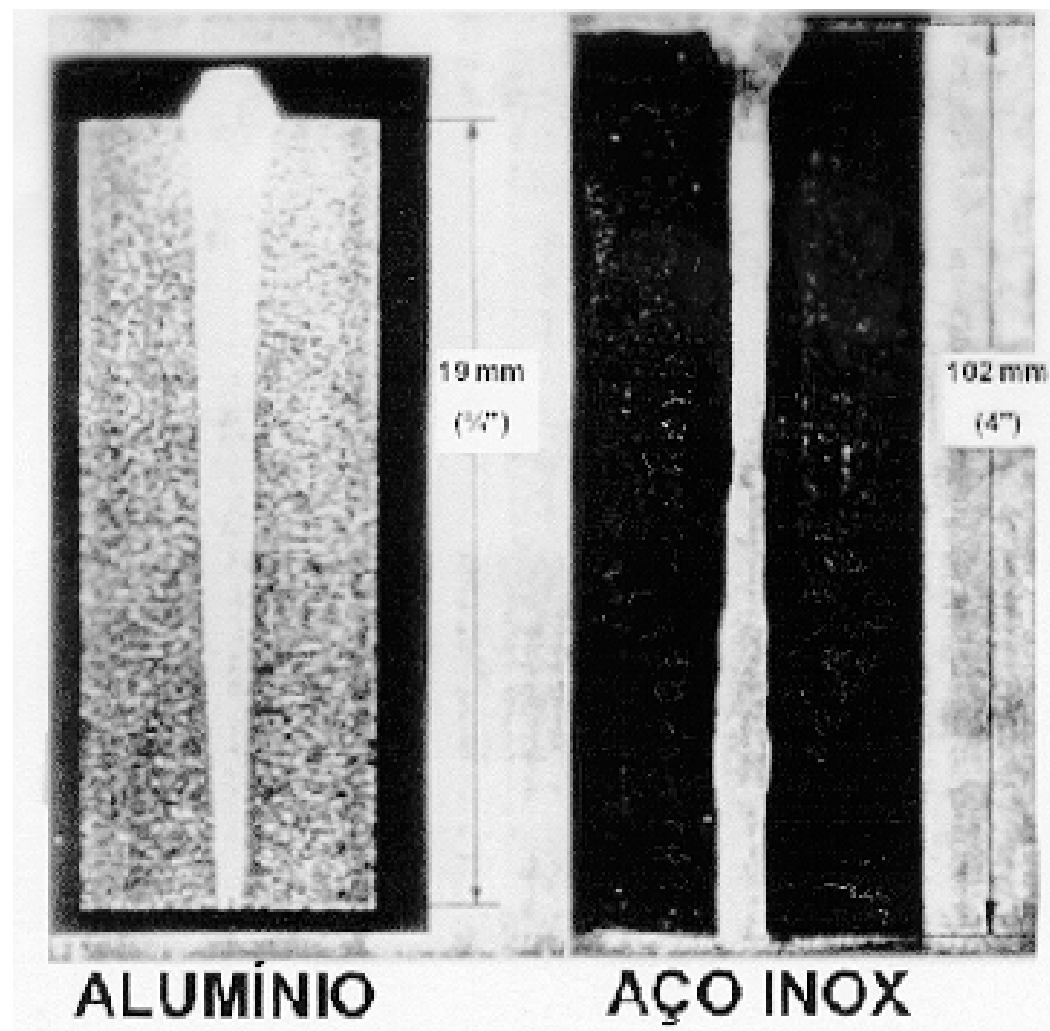

# Soldagem por LASER

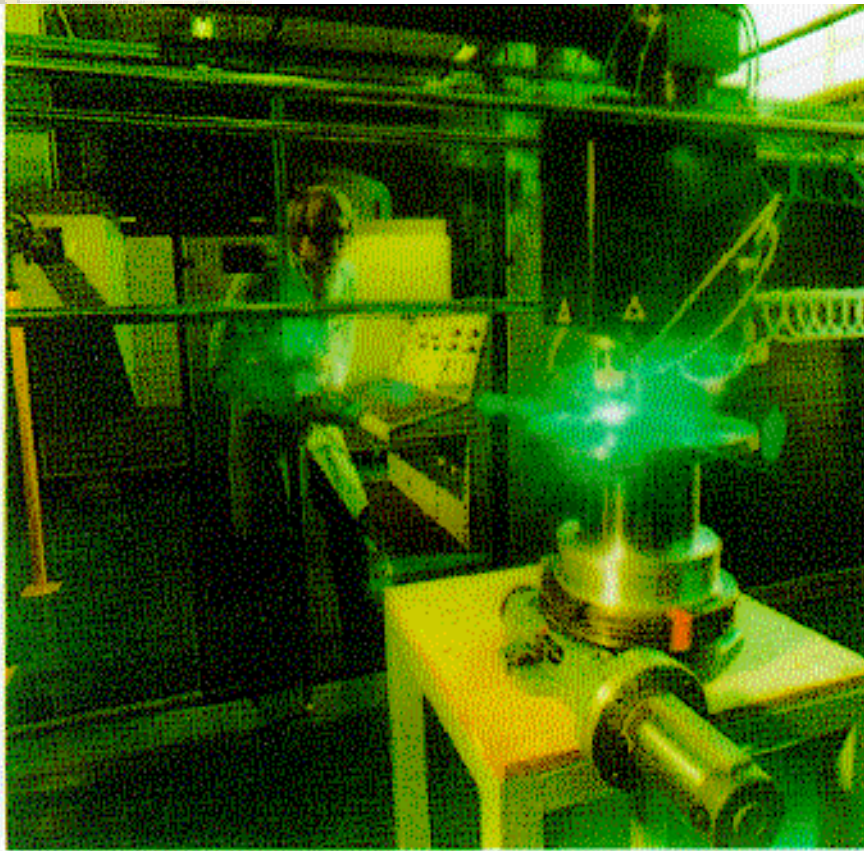



# Soldagem por LASER



Filme laser pulsado



Filme laser contínuo

# Soldagem por Indução (SIN)

Filme

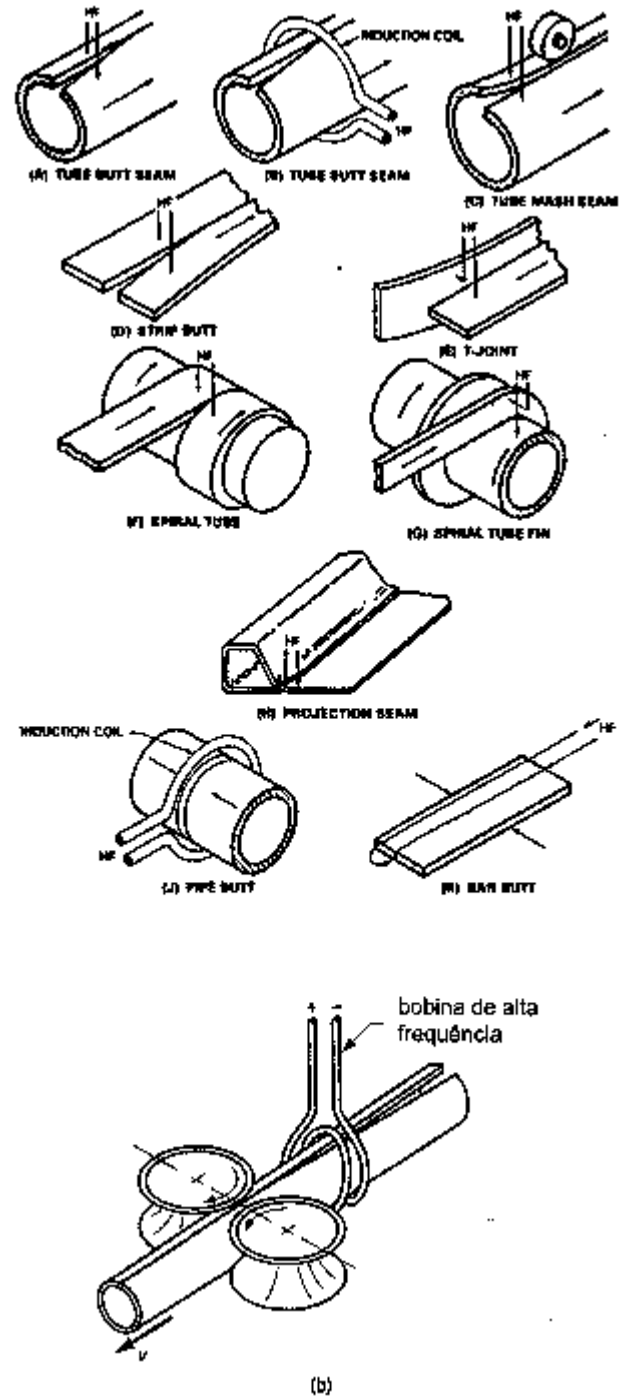



# Soldagem por Aluminotermia (SAL)

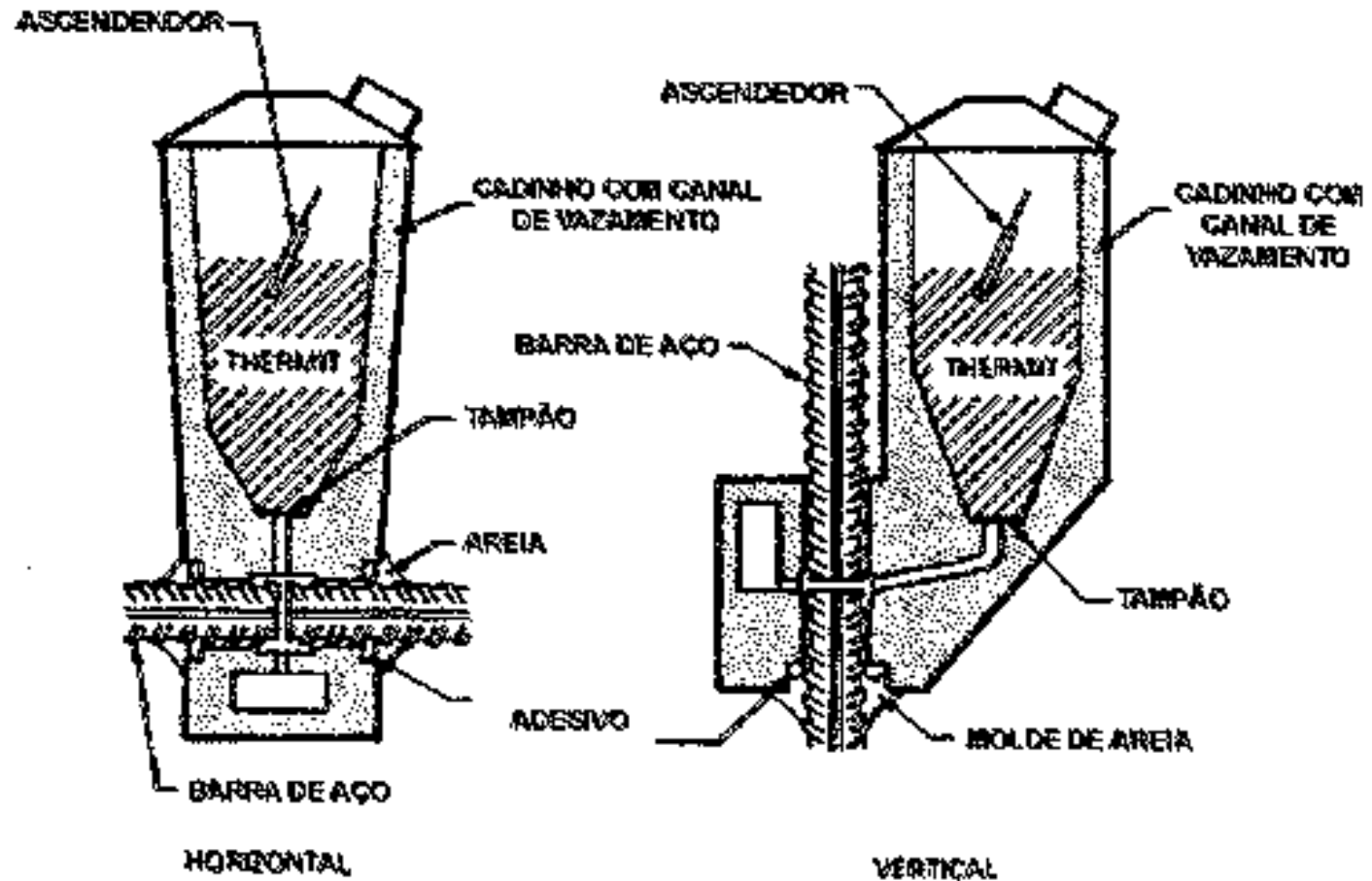

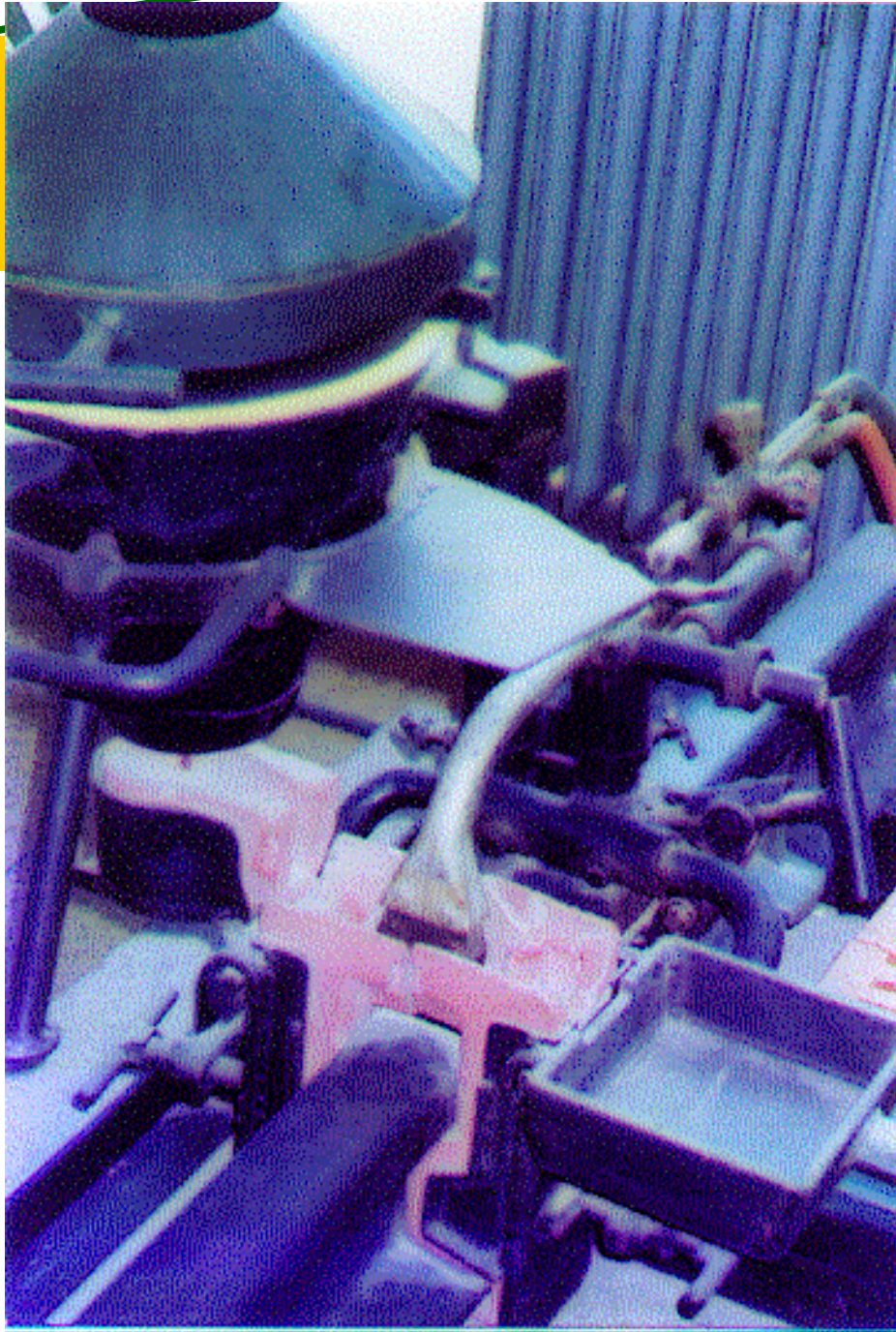

 Filme

# Soldagem no Estado Sólido

## Soldagem por Fricção (SFRI)

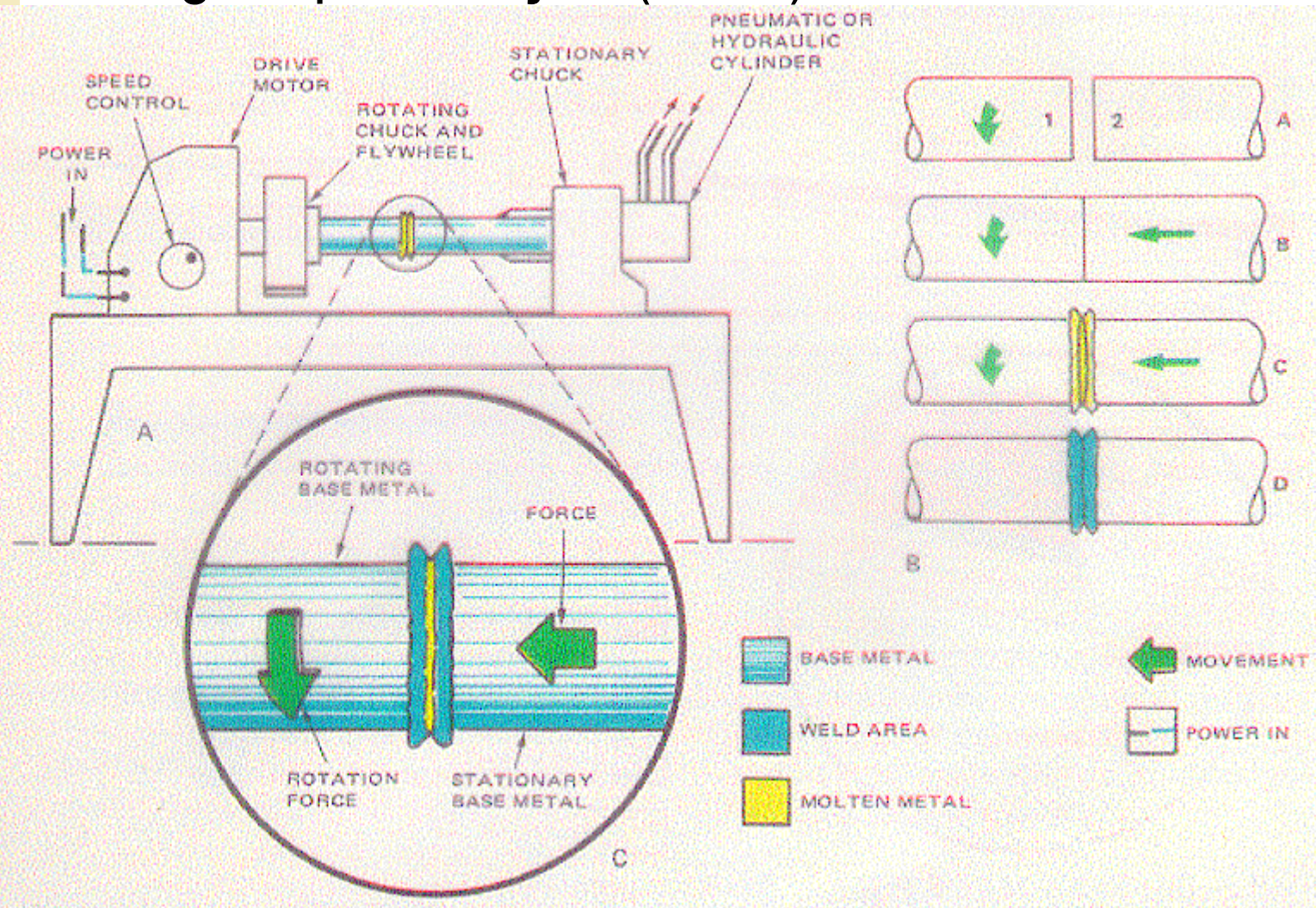

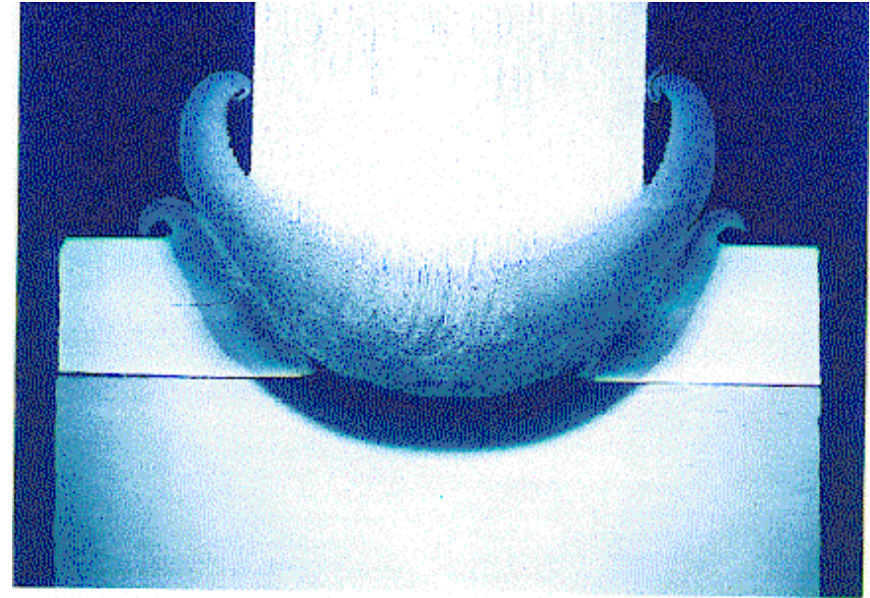
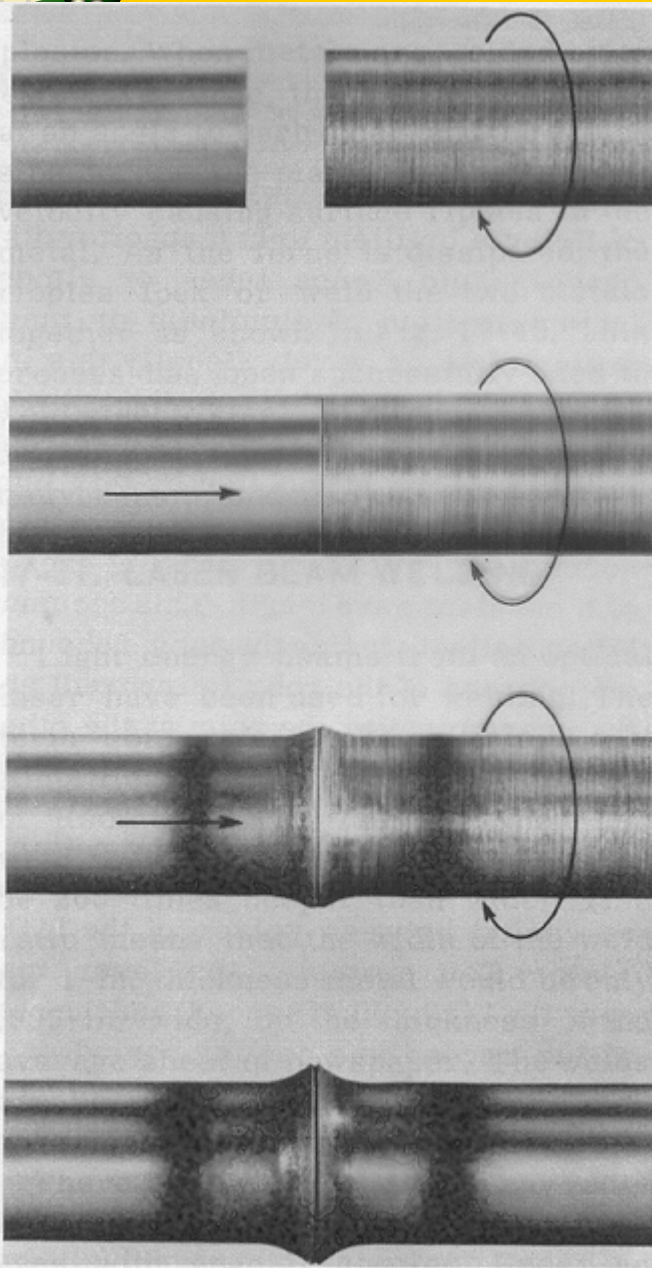
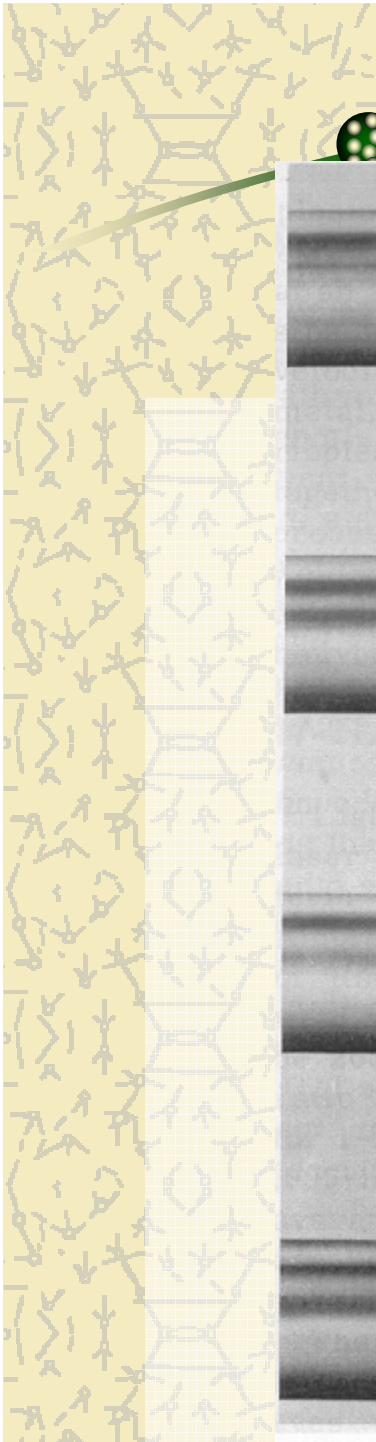

🐝 Filme Tarugo

🐝 Filme Tubo

# Soldagem por Fricção-Mistura

## Friction Stir Welding

### ■ Principle

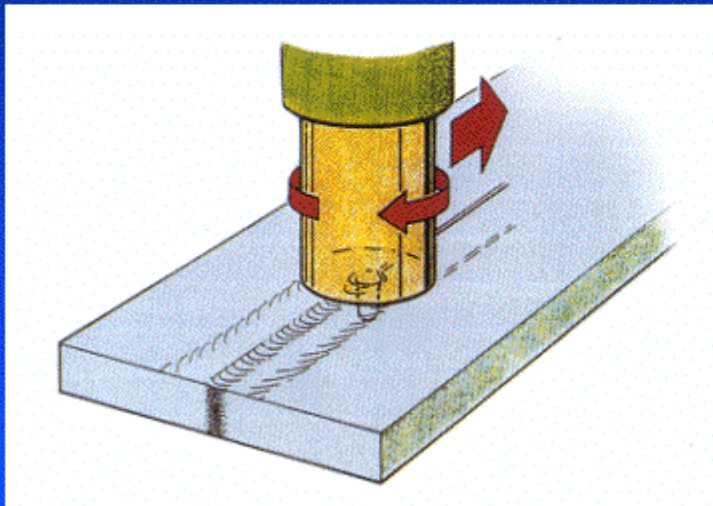

### ■ Example

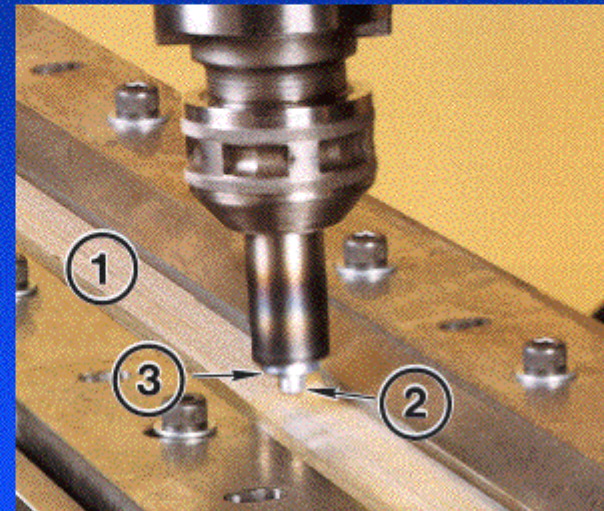



# Soldagem por Fricção-Mistura

☀ Filme FSW liga Mg

☀ Filme FSW liga Al

☀ Filme FSW aço

# Soldagem por Fricção-Mistura

## Typical weld appearance

■ Top surface

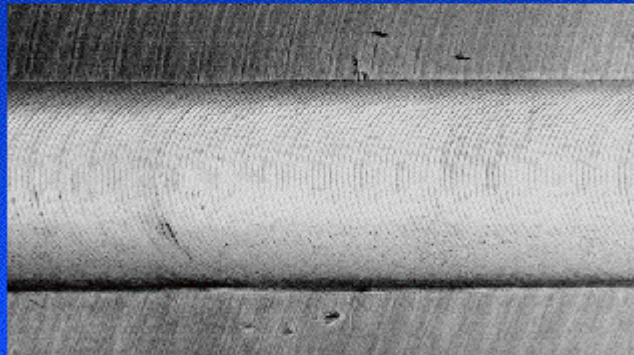

■ Root surface

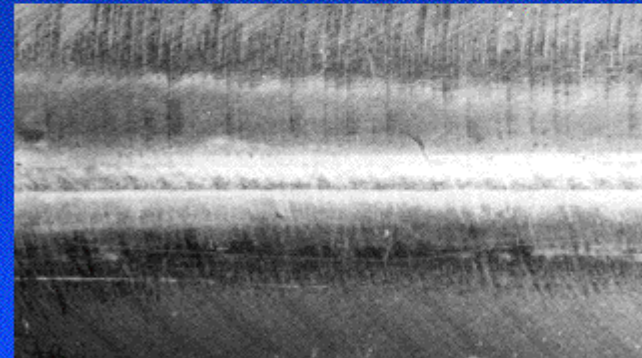

# Microestrutura Típica

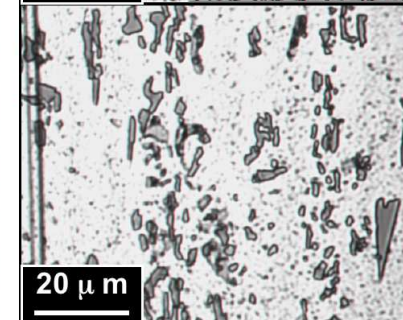
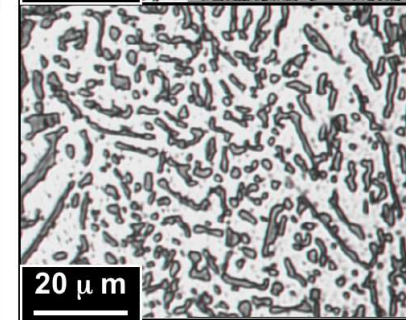
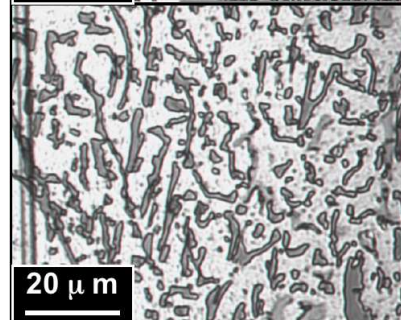
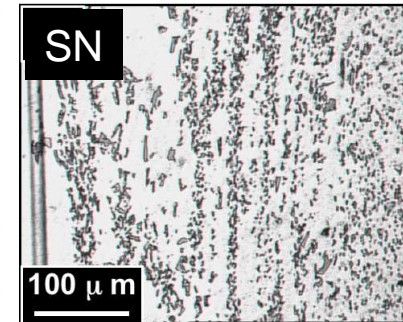
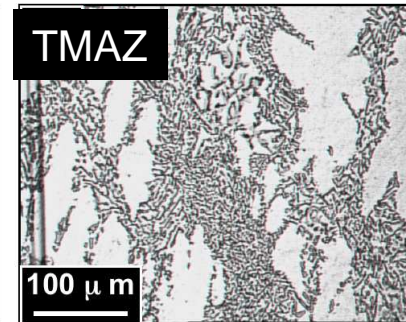
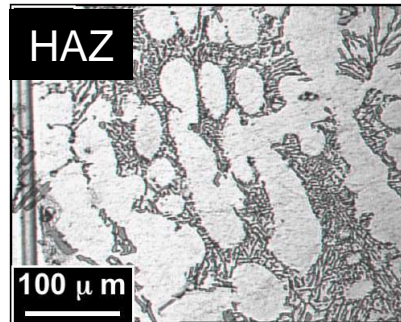
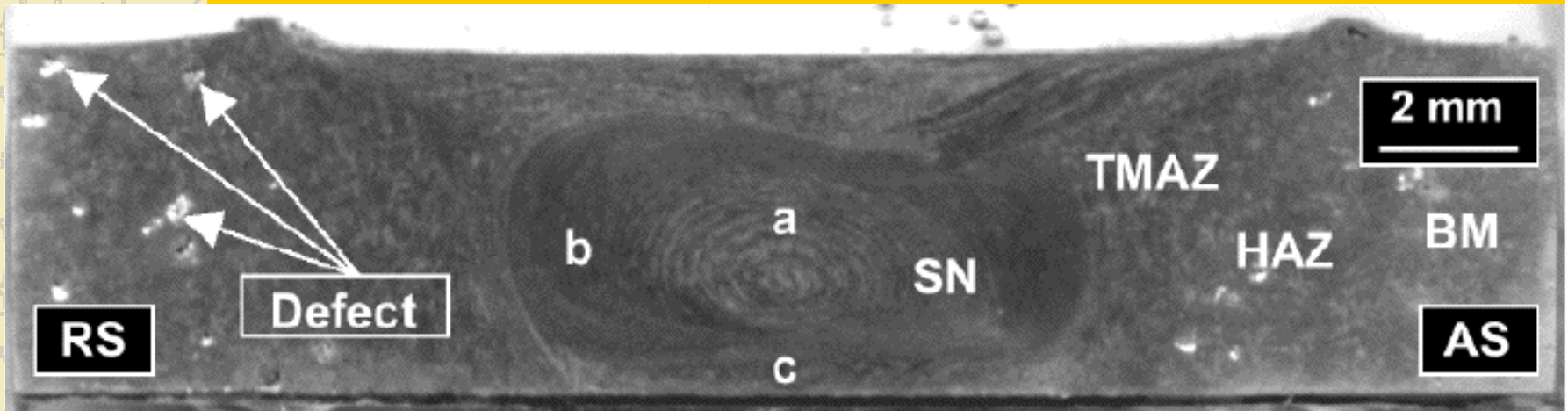

Liga Al-Si



# Soldagem por Explosão (SEXP)

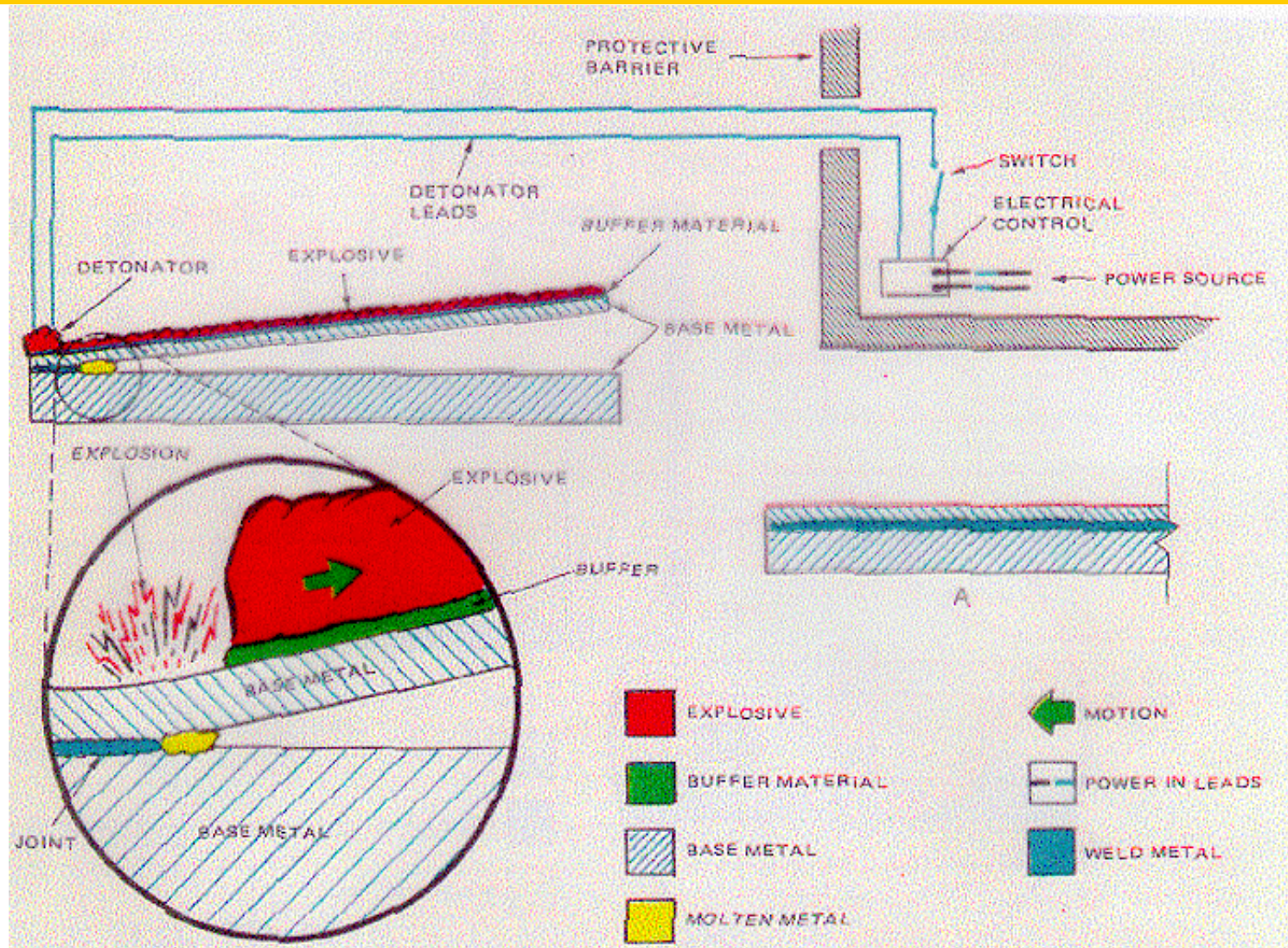

# Soldagem por explosão

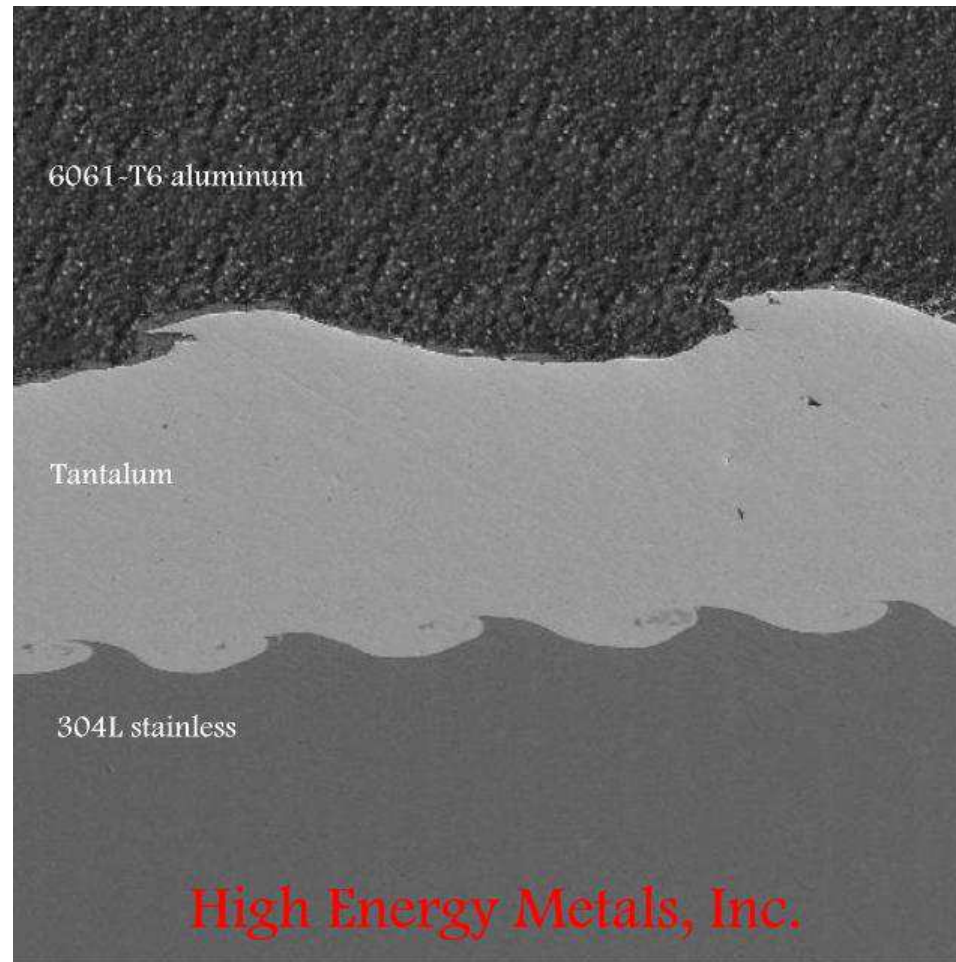

[Animação](#)

[Filme](#)

# Soldagem por Ultrassom

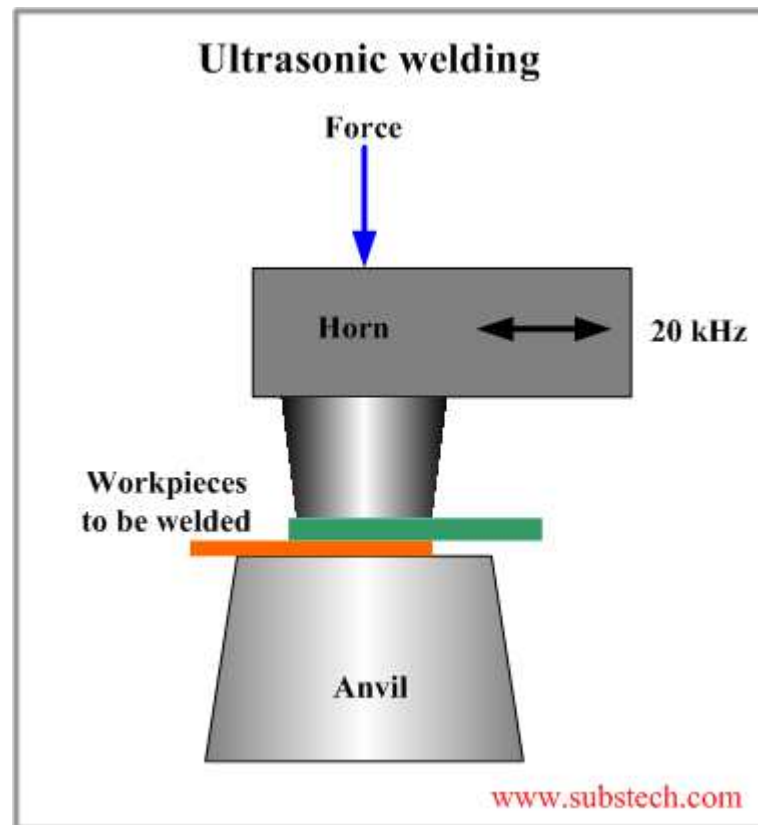

Filme

# Brasagem ( $T > 450^{\circ}\text{C}$ )

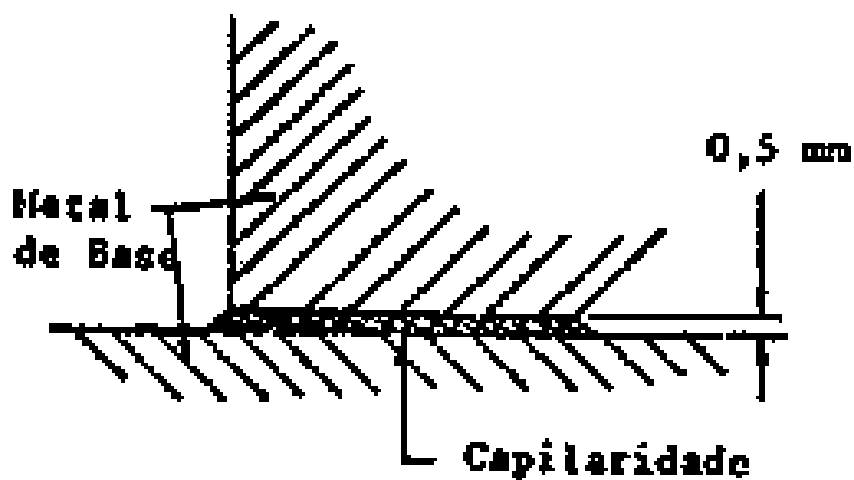

(a) Brasagem

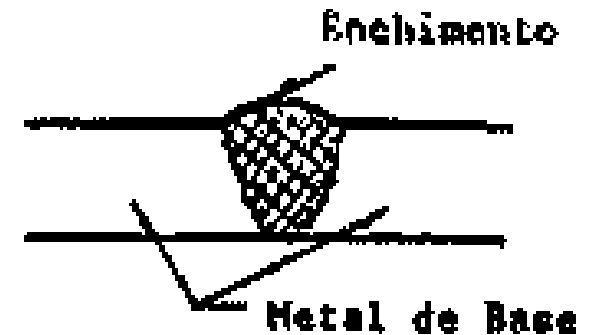

(b) Solda-brasagem

## BRASAGEM E SOLDA-BRASAGEM

Simulação Ni-Cu (capilar de 10 nm)

# Brasagem

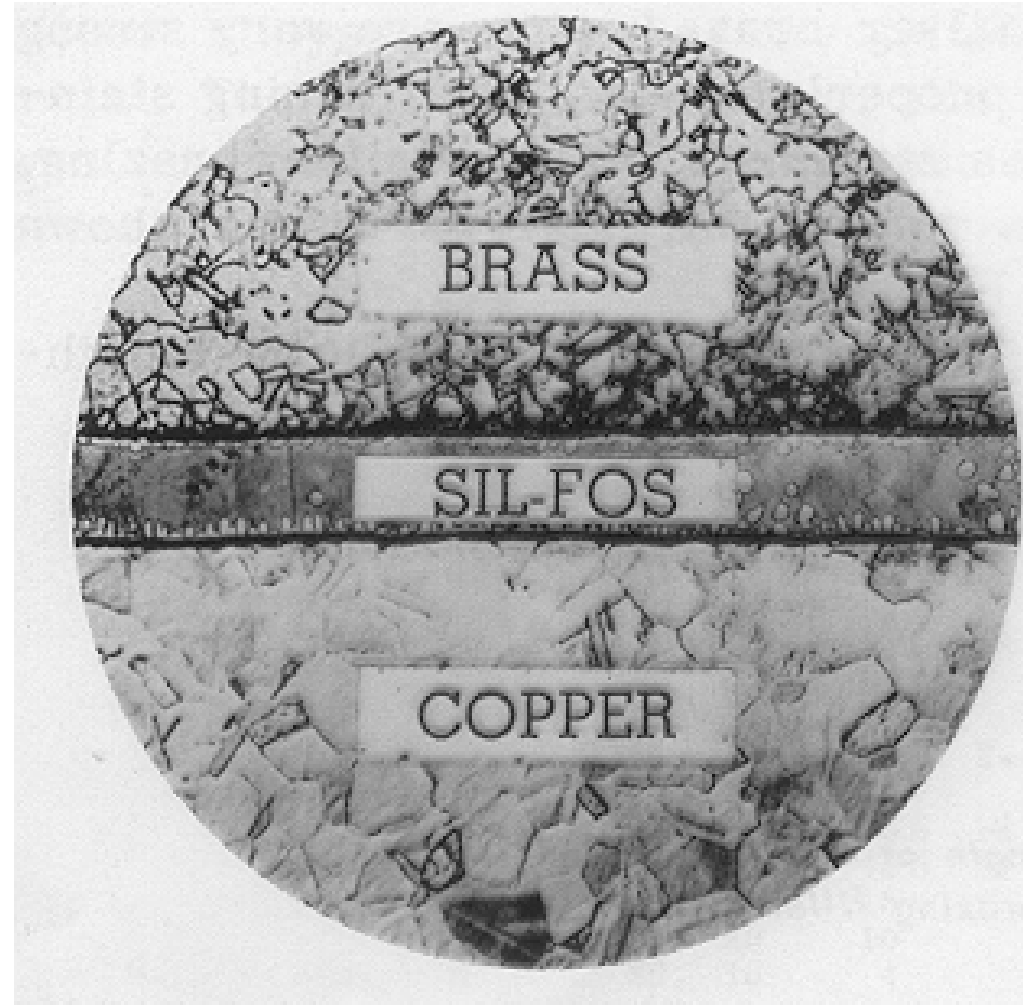

# Brasagem

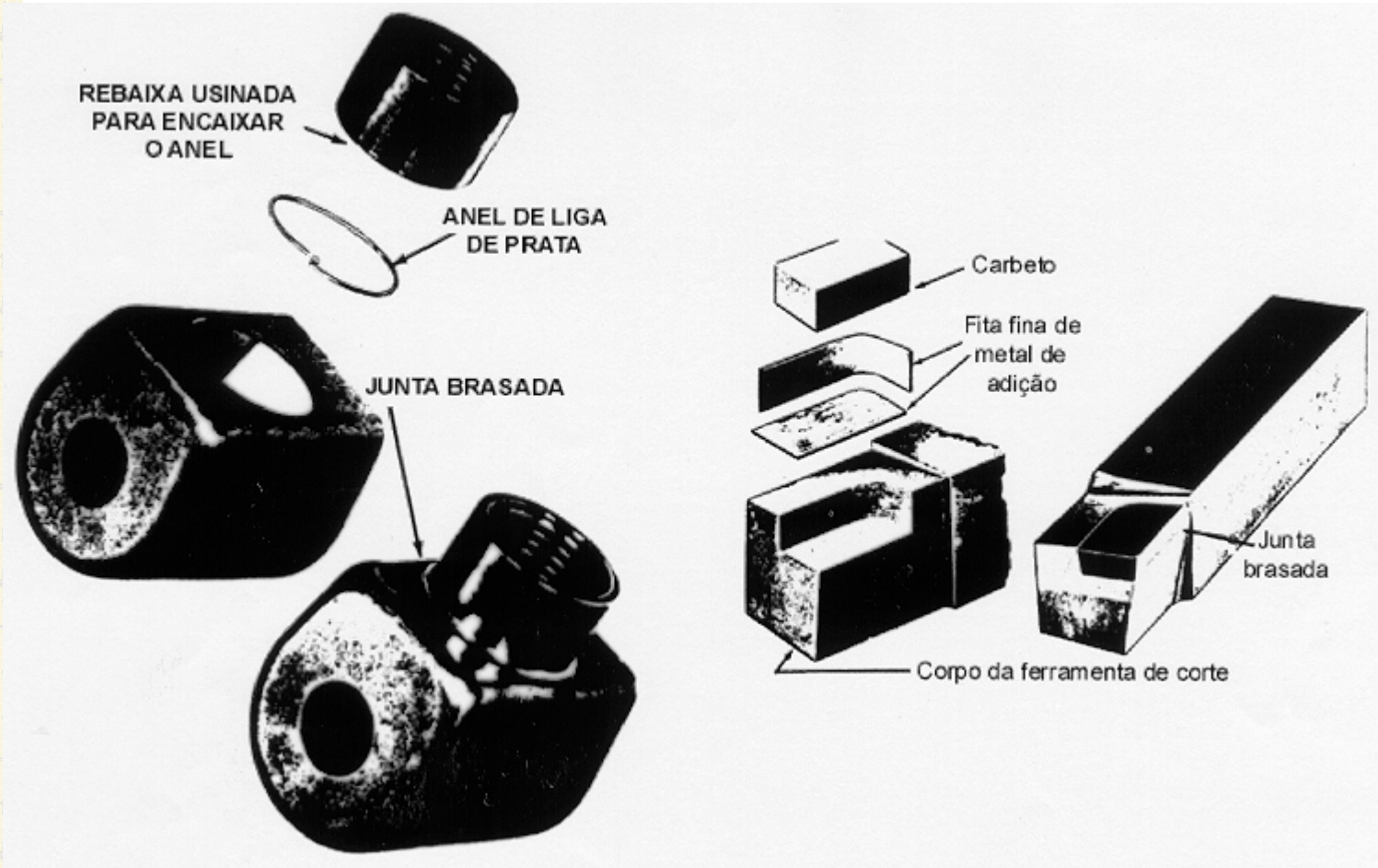

# Solda Brasagem

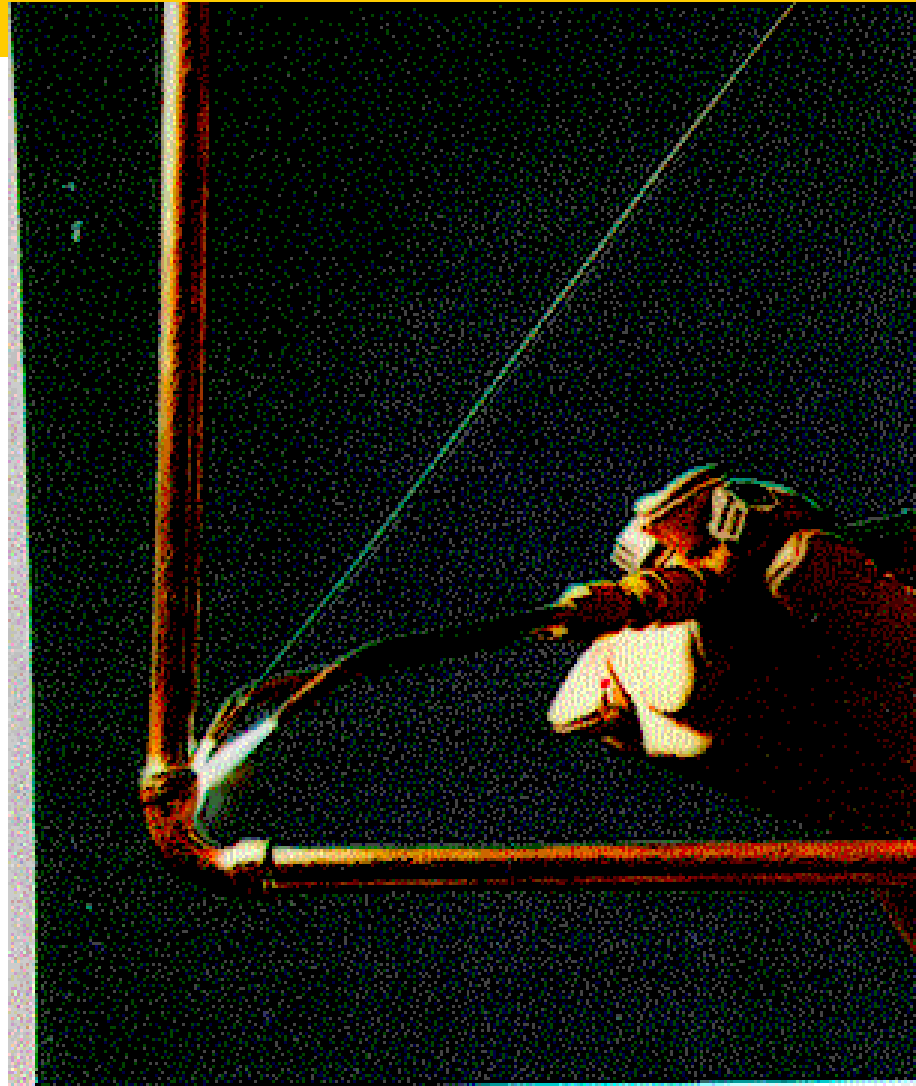

# Solda Branda ( $T < 450^{\circ}\text{C}$ )

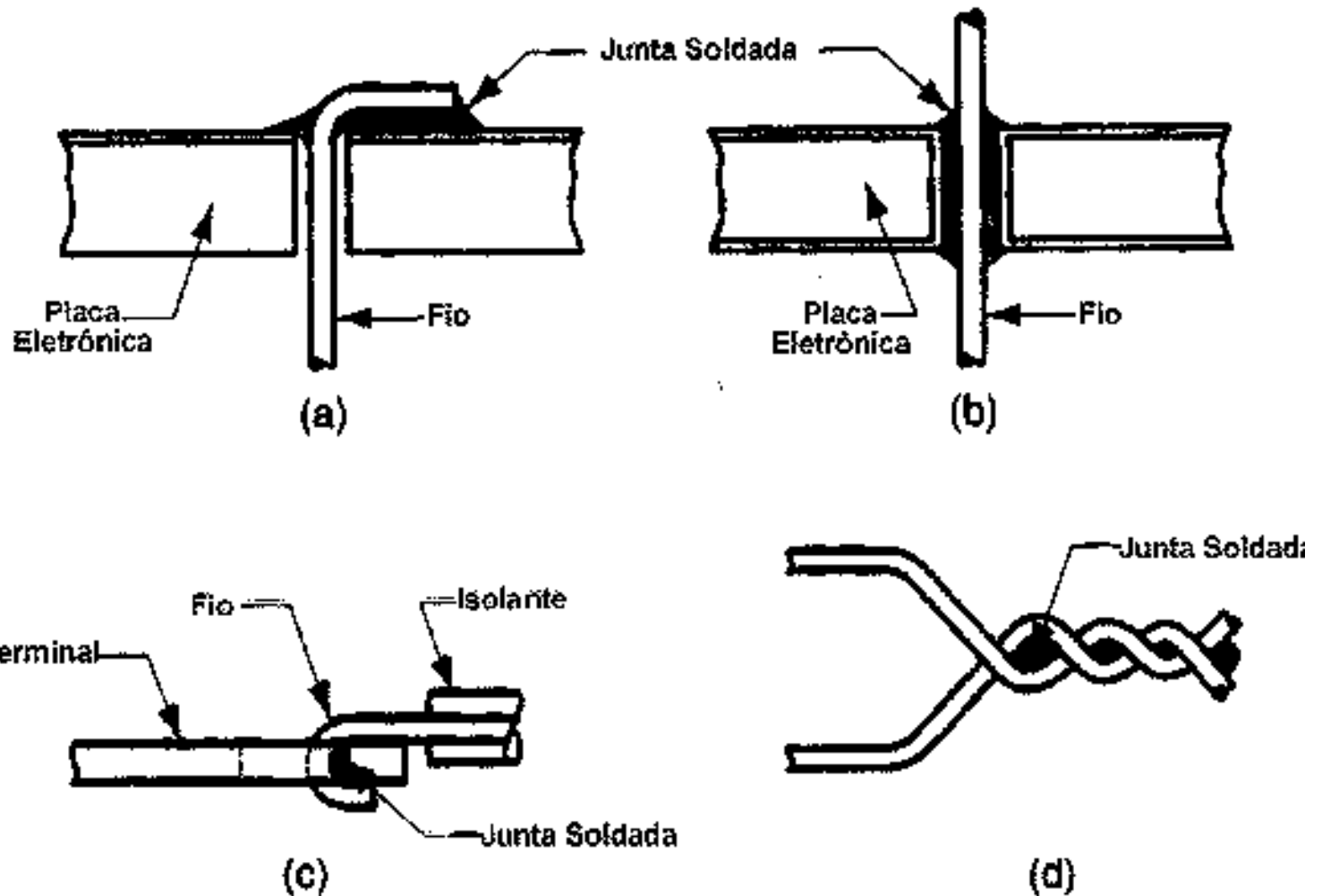



# Solda Branda

**Componentes**

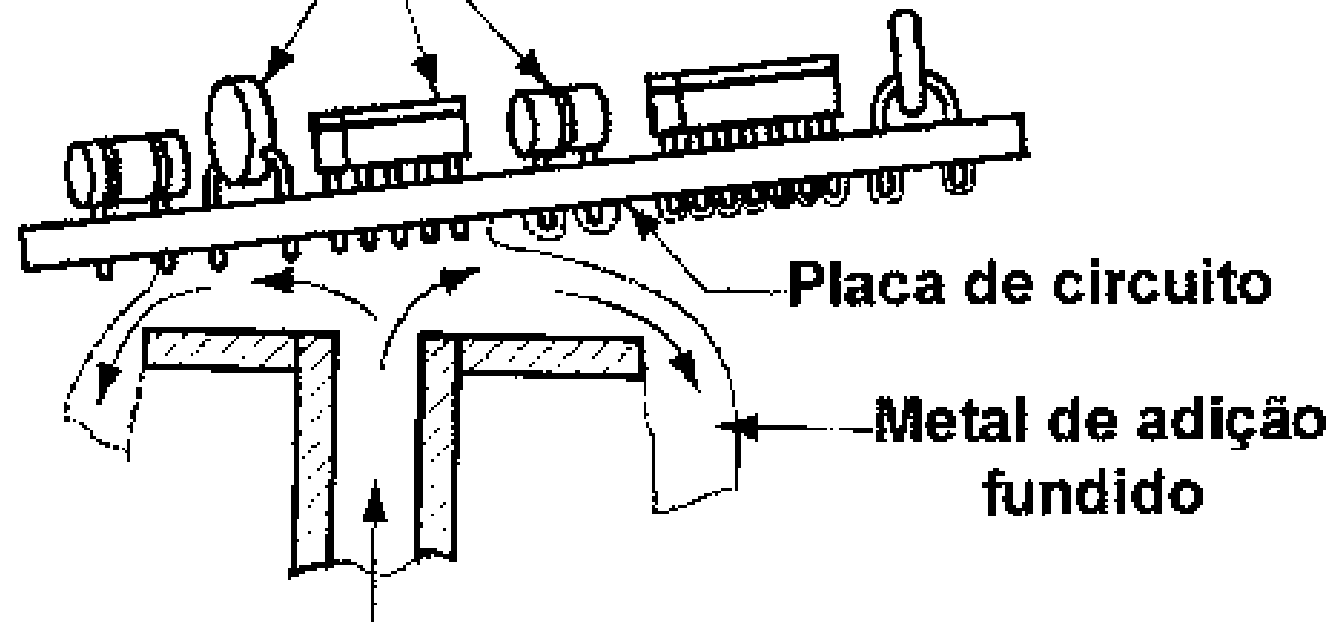

# Bibliografia

- ✚ KIMINAMI, Claudio S.; CASTRO, Walman B. e OLIVEIRA, Marcelo F. Introdução aos processos de fabricação de produtos metálicos, Blucher, São Paulo, 2013.
- ✚ KALPAKJIAN, Serope e SCHMID, Steven. Manufacturing processes for engineering materials, 5a ed., Pearson Education, New Jersey, 2007.
- ✚ Emilio Wainer, Sergio Duarte Brandi e Fabio Decourt Homem de Mello. Soldagem: processos e metalurgia, São Paulo: Edgard Blucher, 1992.
- ✚ Paulo Villani Marques. Tecnologia da soldagem, Belo Horizonte: Esab, 1991.
- ✚ AWS Welding Handbook, vol. 2.
- ✚ ASM International. ASM Handbooks Online, vol. 6A e vol. 6, <http://products.asminternational.org/hbk/index.jsp>