

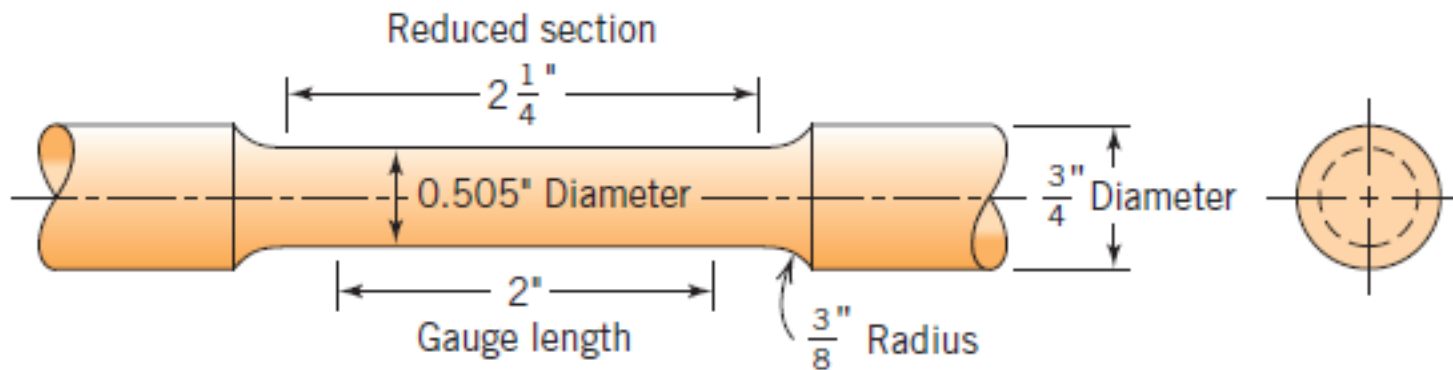

# Propriedades Mecânicas

# [ Ensaio de Tração ]



$$\sigma = \frac{F}{A_0}$$

$$\epsilon = \frac{l_i - l_0}{l_0} = \frac{\Delta l}{l_0}$$

# [ Tração ]

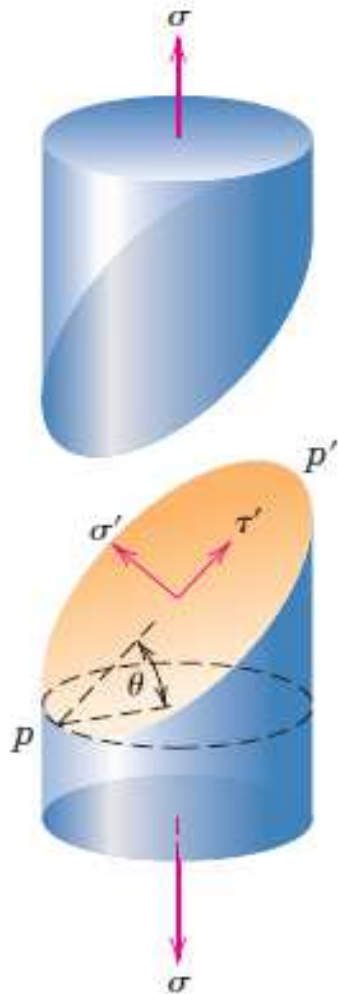

$$\sigma' = \sigma \cos^2 \theta = \sigma \left( \frac{1 + \cos 2\theta}{2} \right)$$

$$\tau' = \sigma \sin \theta \cos \theta = \sigma \left( \frac{\sin 2\theta}{2} \right)$$

# [ Deformação elástica ]

- Regime elástico linear (lei de Hook)

$$\sigma = E\epsilon$$

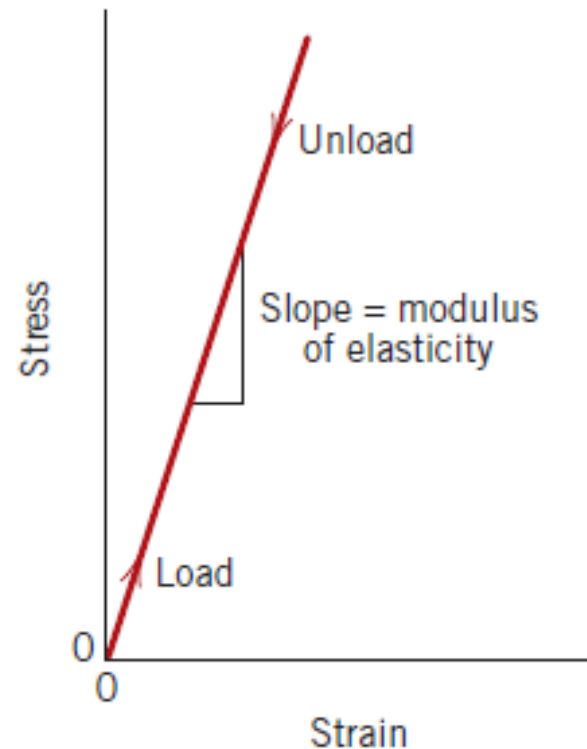

# [ Deformação elástica ]

- Regime elástico não linear

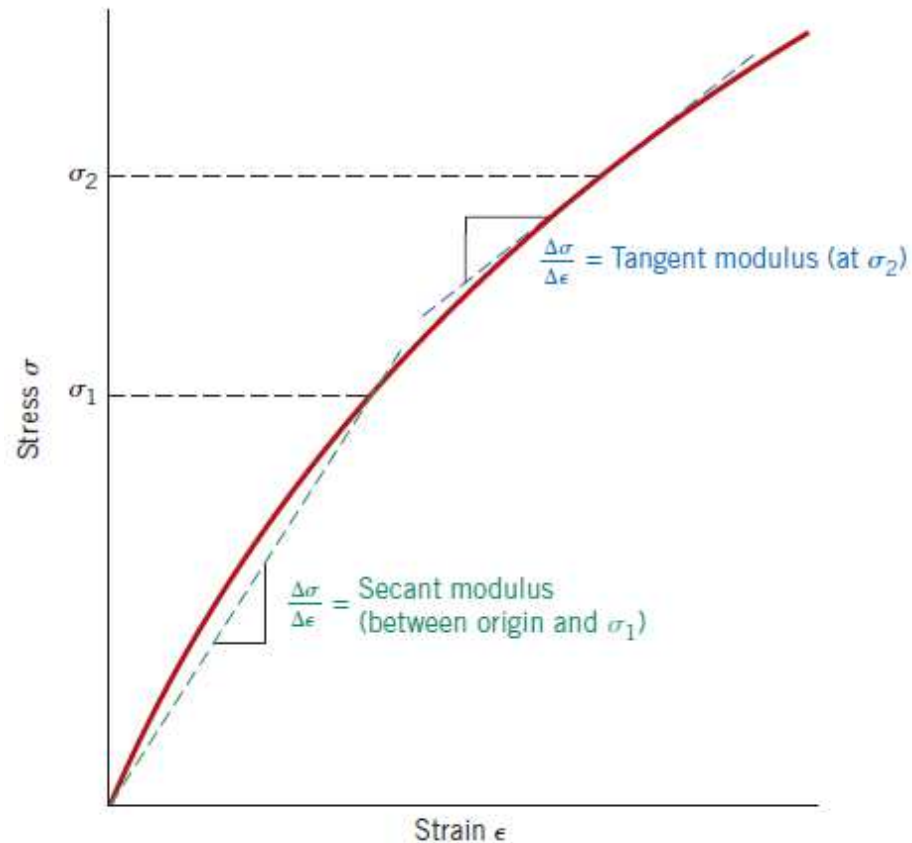

# Origem do módulo de elasticidade

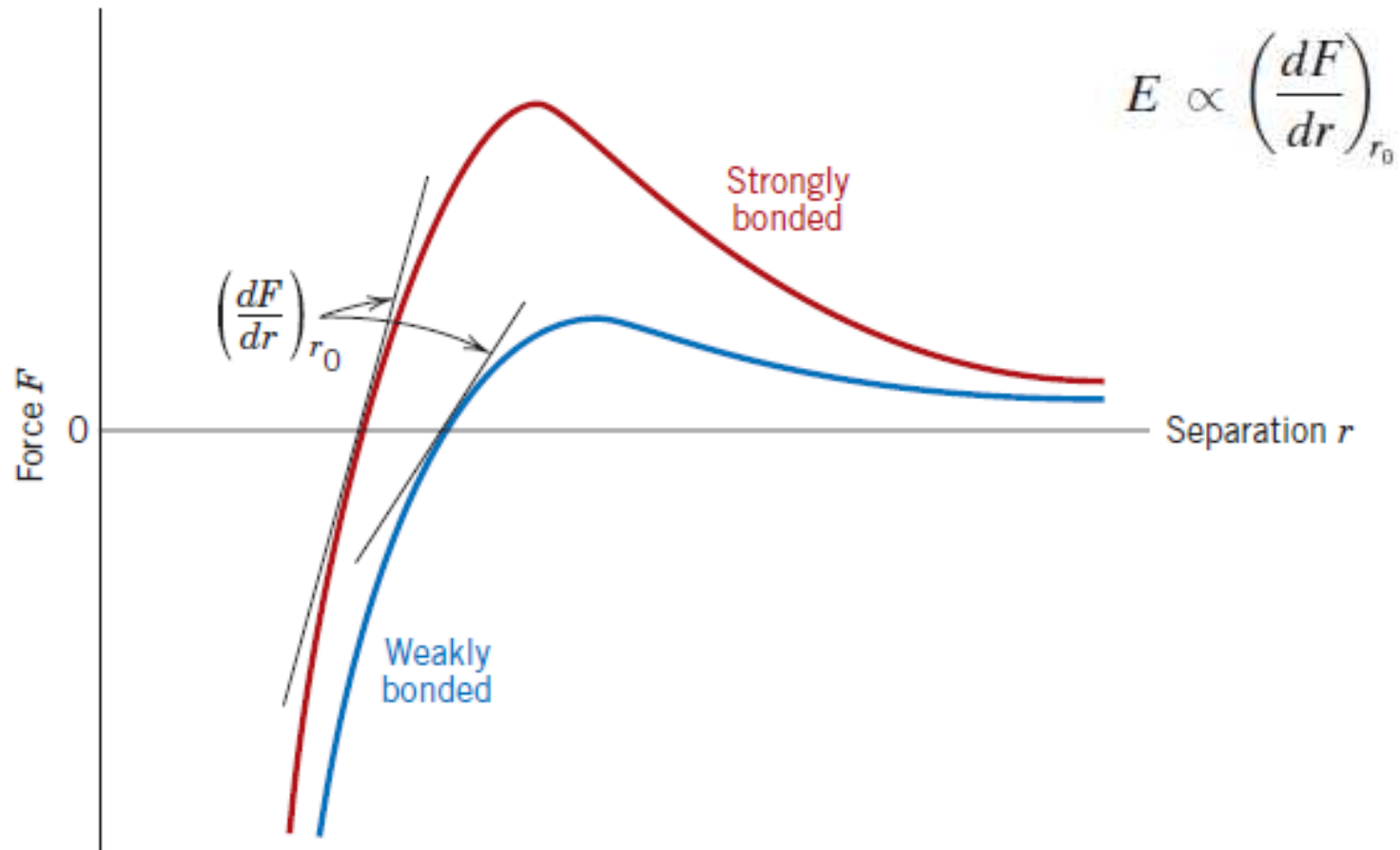

# [ Outras propriedades elásticas ]

- Módulo de cisalhamento

$$\tau = G\gamma$$

- Razão de Poisson

$$\nu = -\frac{\epsilon_x}{\epsilon_z} = -\frac{\epsilon_y}{\epsilon_z}$$

- p/ material isotrópico

$$E = 2G(1 + \nu)$$

# [ Deformação plástica ]

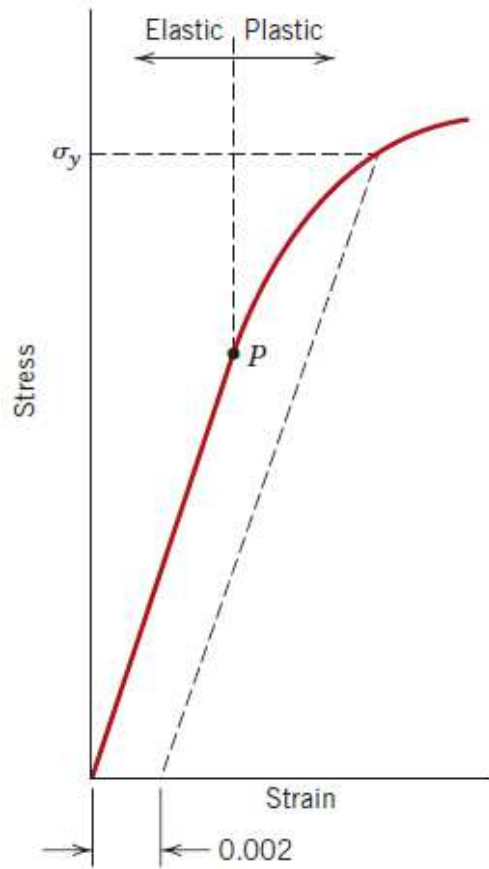

Limite não definido

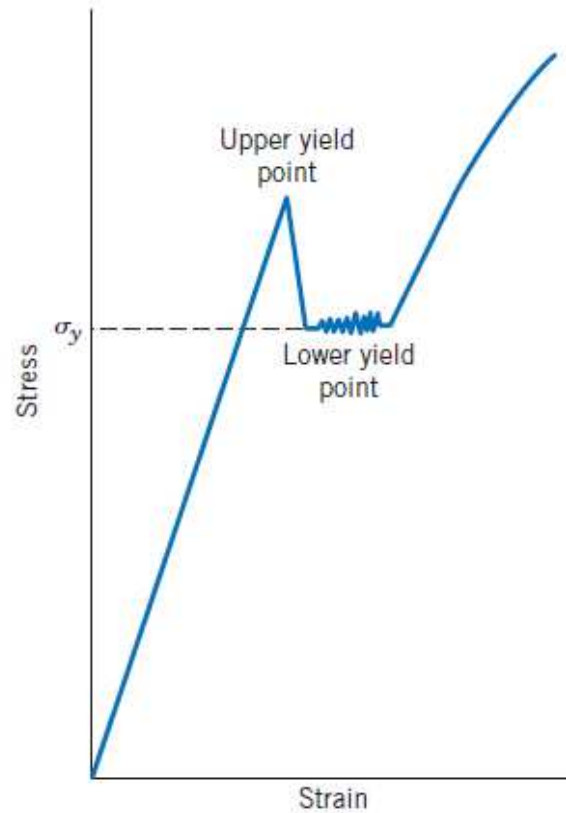

Limite bem definido



# Tensão x Deformação p/ um metal típico

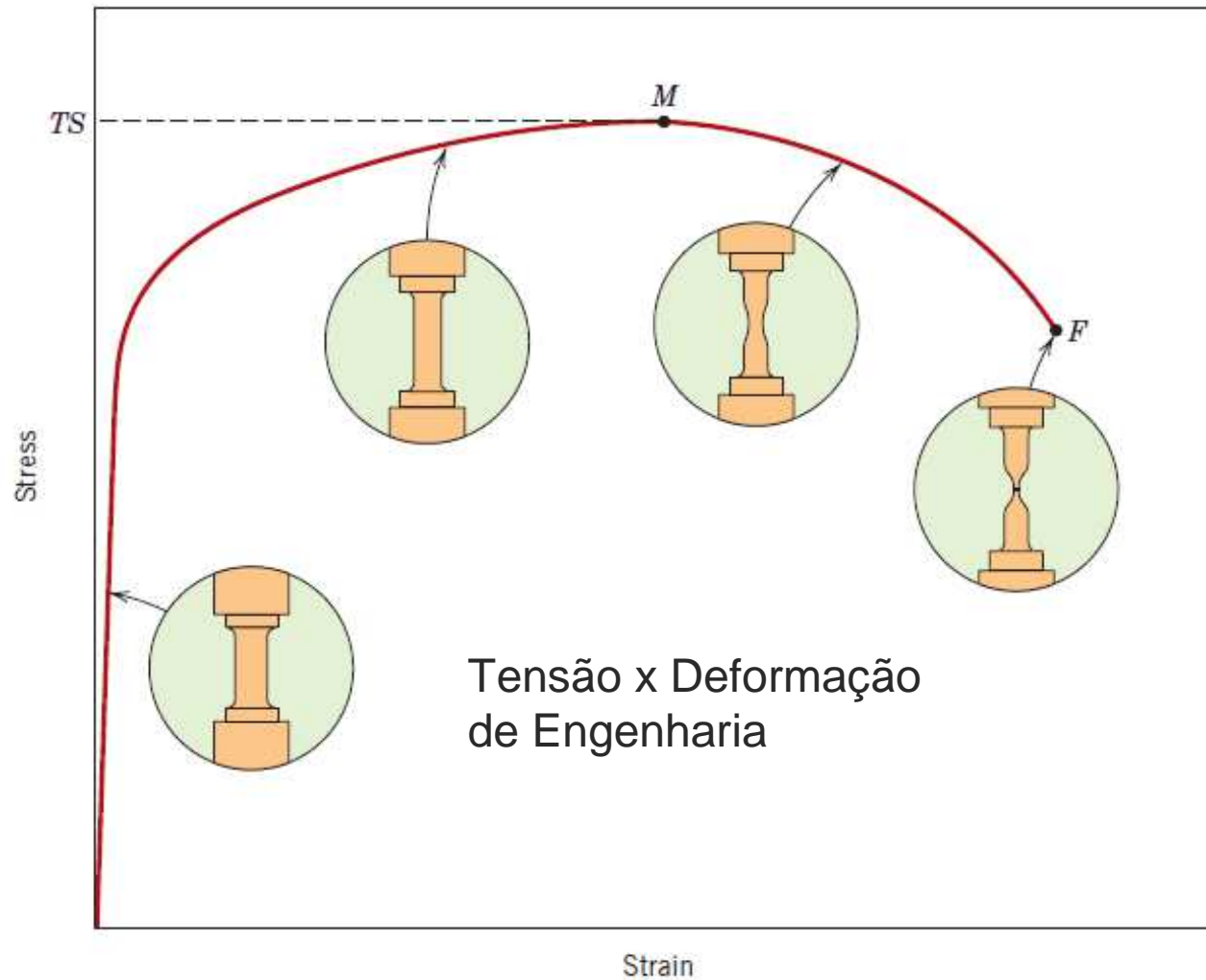

# [ Ductilidade ]

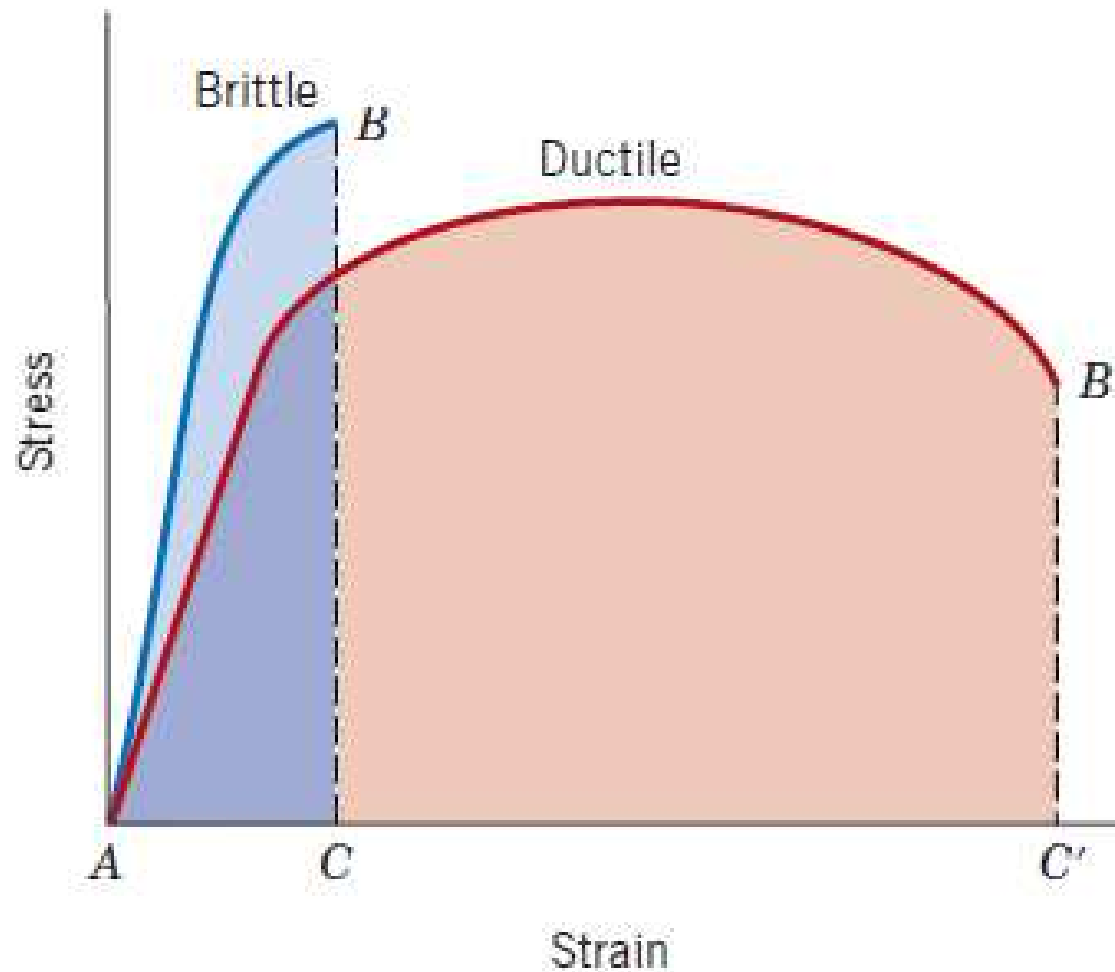

$$\%EL = \left( \frac{l_f - l_0}{l_0} \right) \times 100$$

$$\%RA = \left( \frac{A_0 - A_f}{A_0} \right) \times 100$$

# [ Resiliência ]

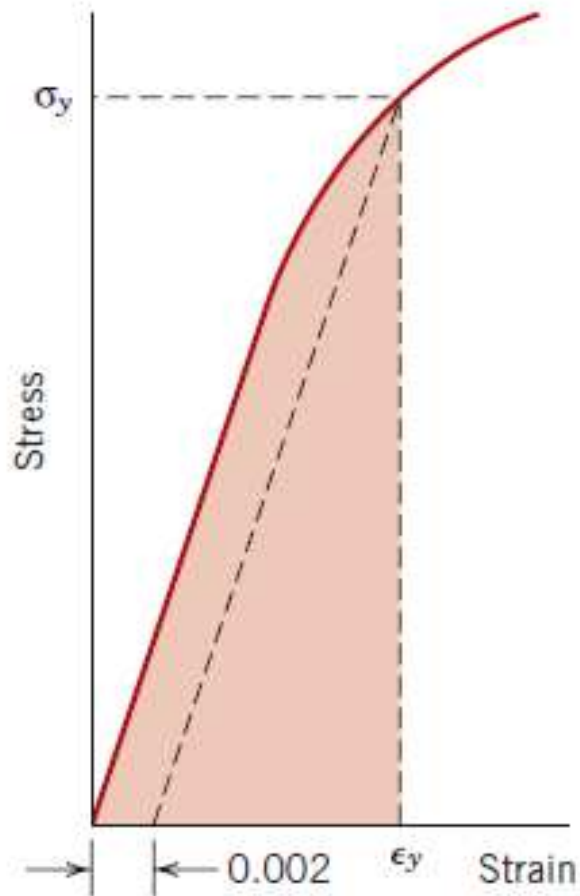

$$U_r = \int_0^{\epsilon_y} \sigma d\epsilon$$

$$U_r = \frac{1}{2} \sigma_y \epsilon_y$$

$$U_r = \frac{1}{2} \sigma_y \epsilon_y = \frac{1}{2} \sigma_y \left( \frac{\sigma_y}{E} \right) = \frac{\sigma_y^2}{2E}$$

# [ Tenacidade ]

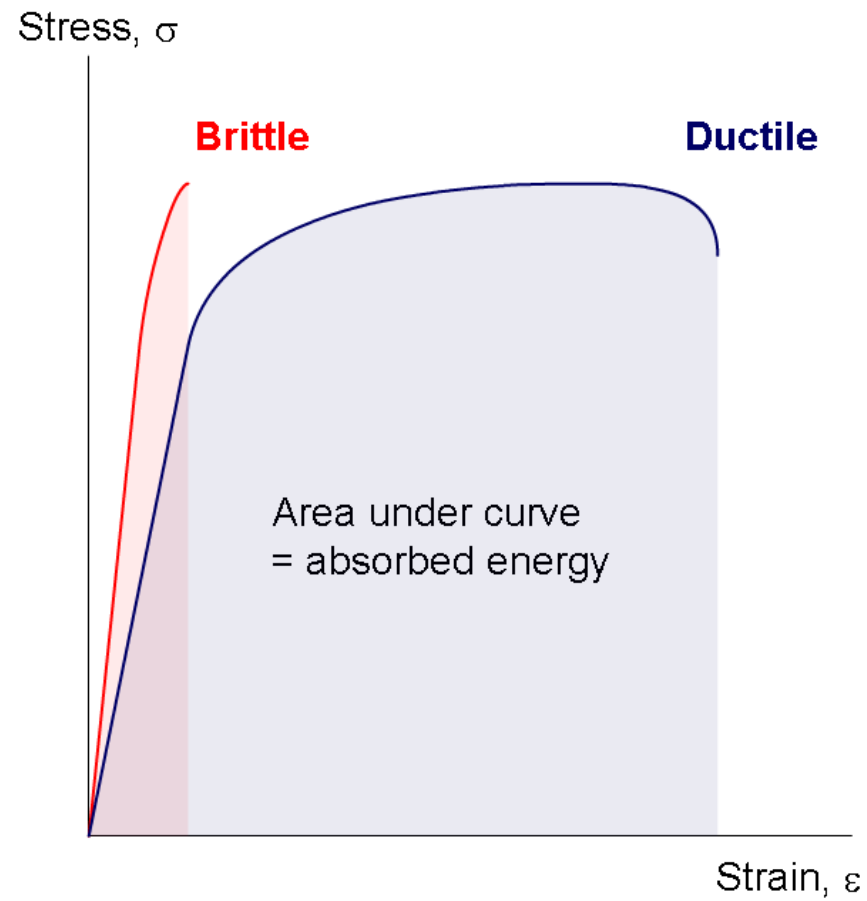

# Tensão e Deformação Verdadeiras em Tração

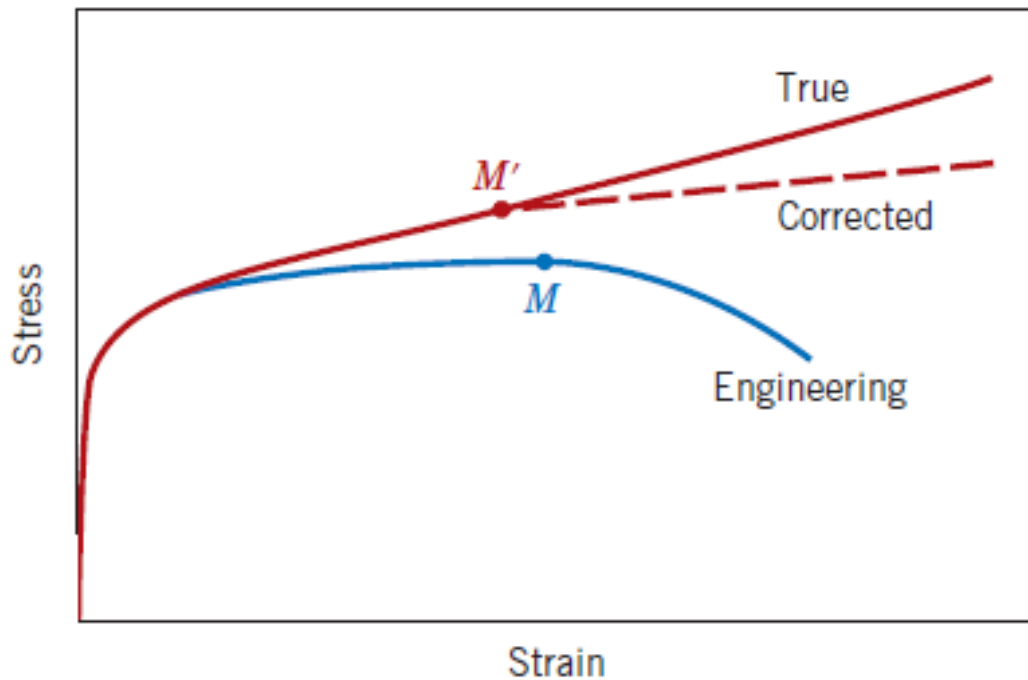

p/ metais:  $\sigma_T = K\epsilon_T^n$

$$\sigma_T = \frac{F}{A_i}$$

$$\epsilon_T = \ln \frac{l_i}{l_0}$$

$$\sigma_T = \sigma(1 + \epsilon)$$

$$\epsilon_T = \ln(1 + \epsilon)$$

# [ Encruamento de metais ]

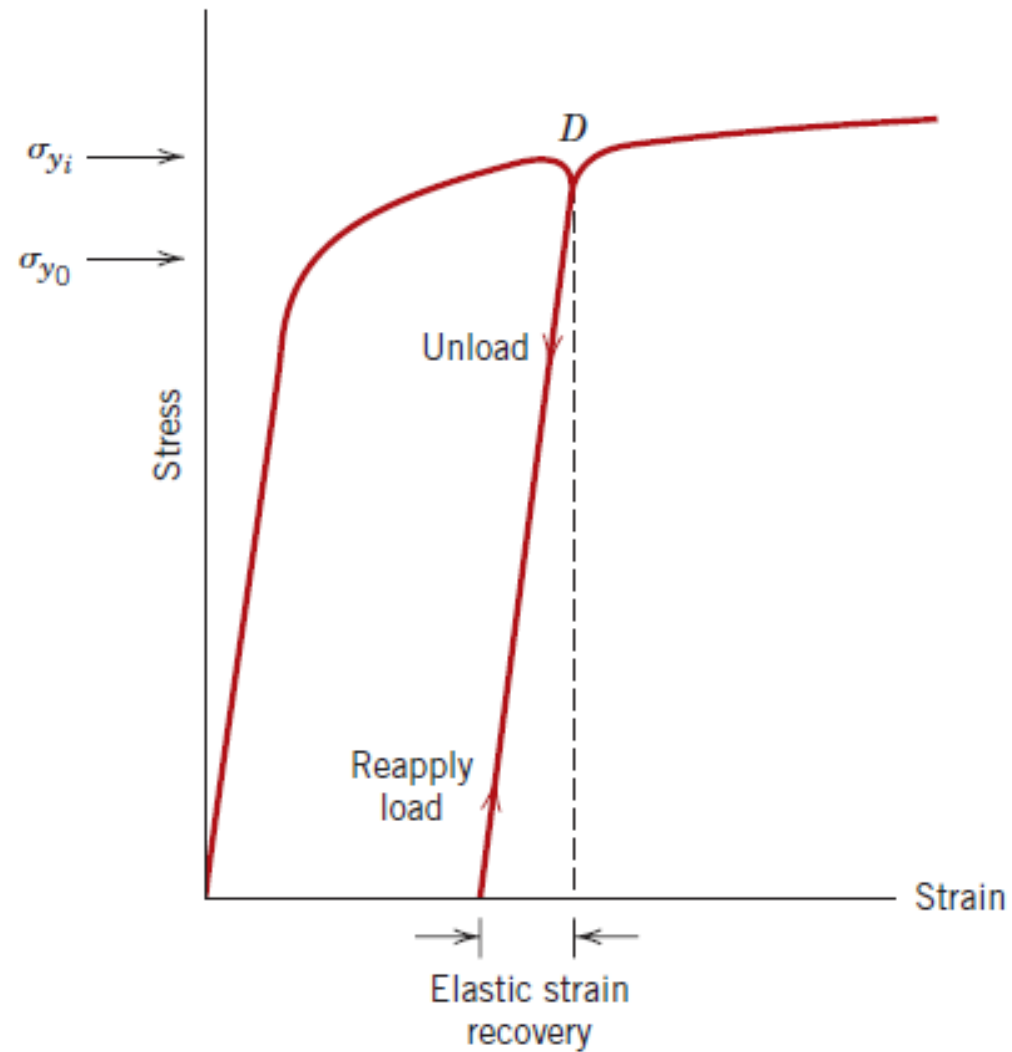

# [ Durezza ]

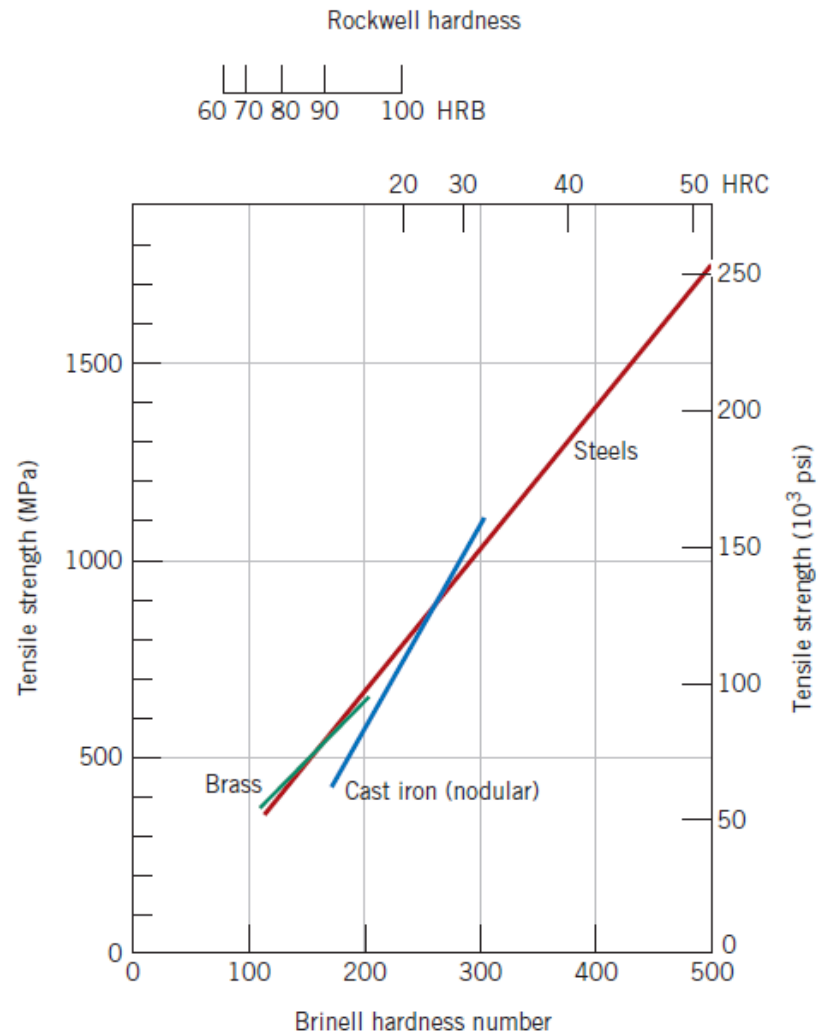

# [ Fratura dúctil ou frágil ]

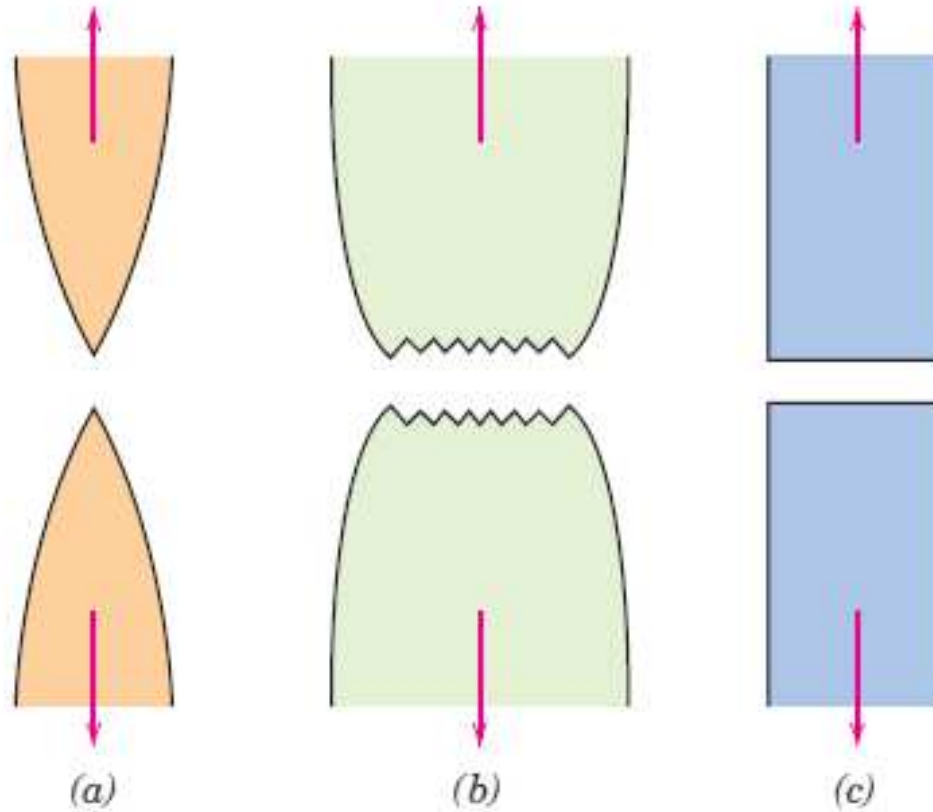



# [ Fratura “taça – cone” (dúctil) ]

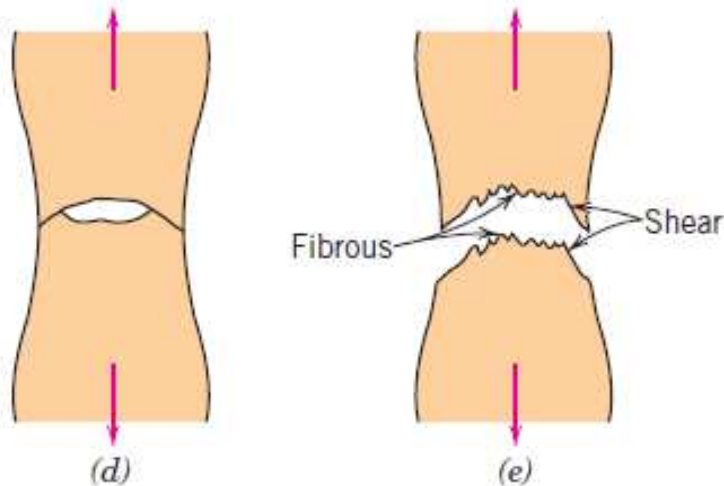
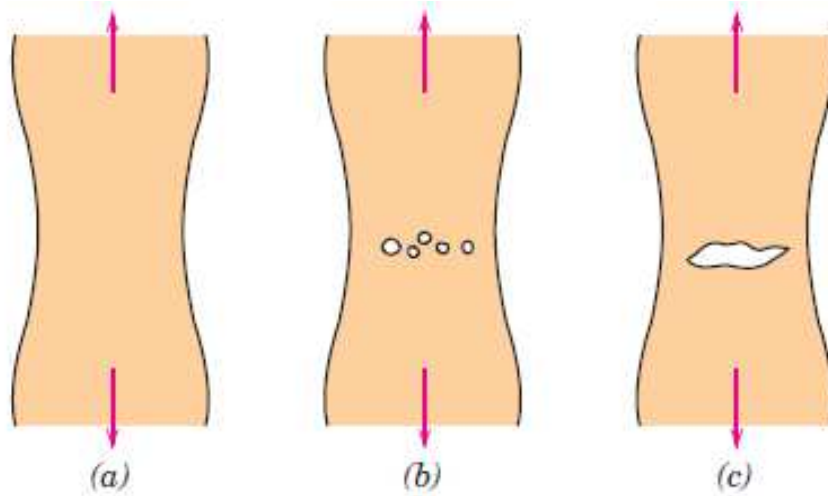

# [ Fratura frágil ]

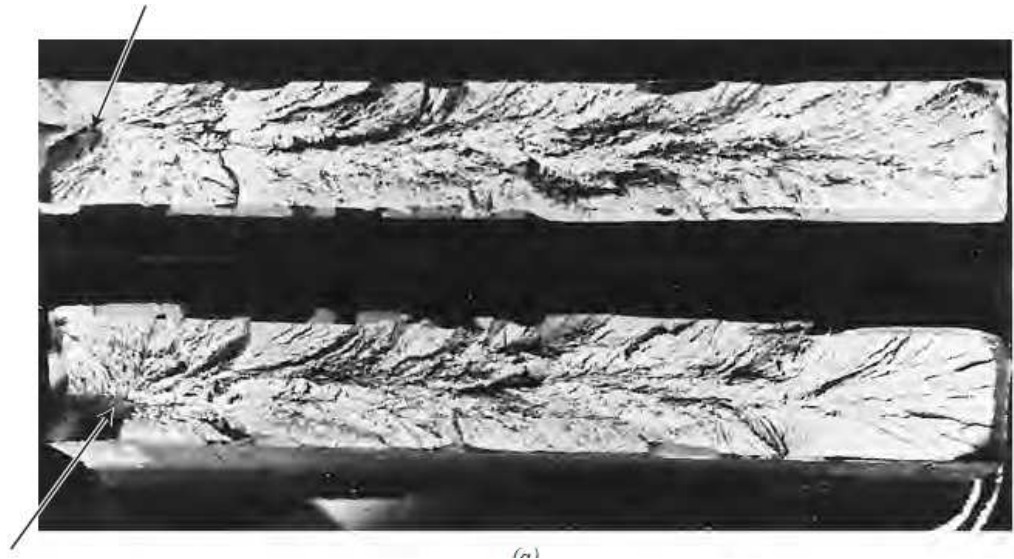

# Fratura Transgranular e Intergranular

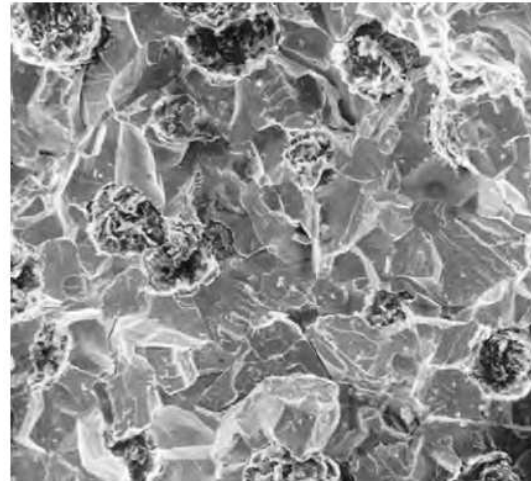
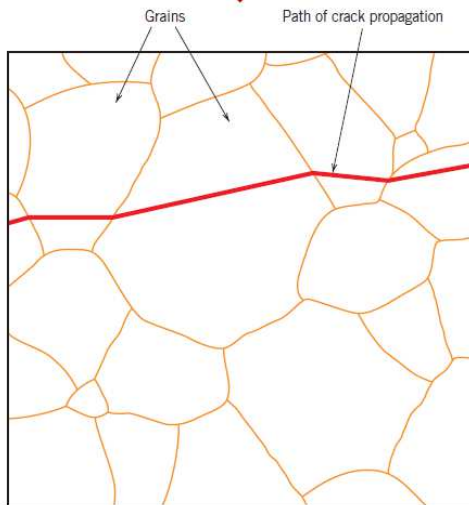

Transgranular

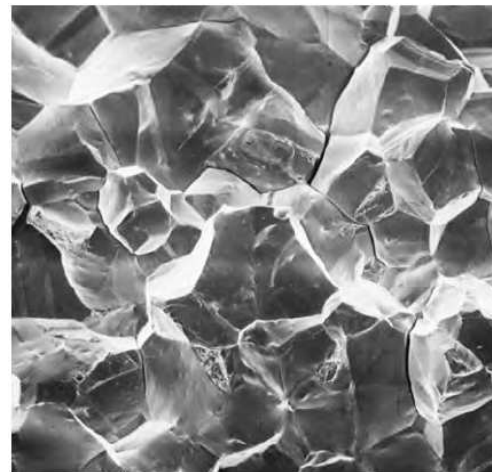
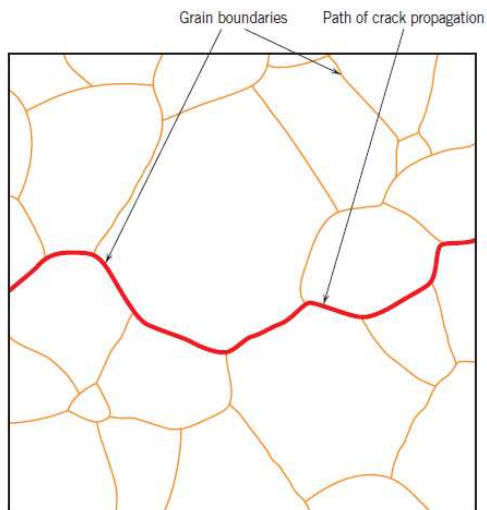

Intergranular

# [ Concentração de tensão ]

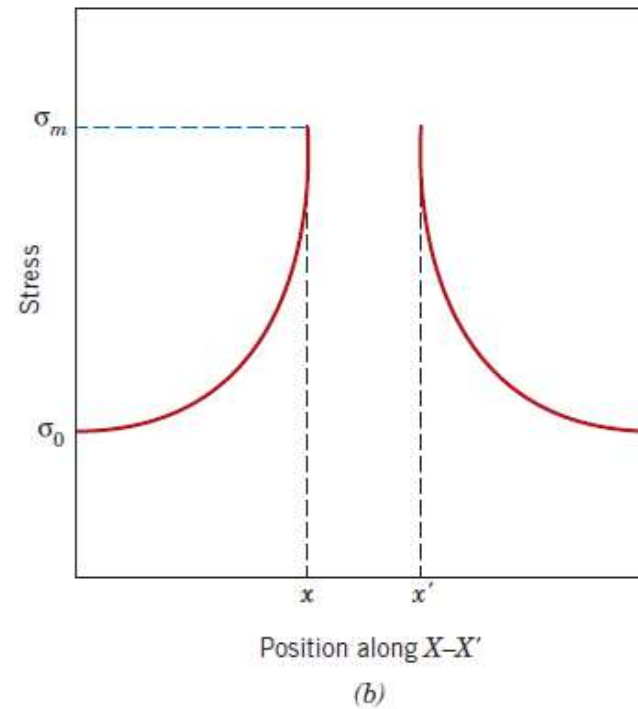
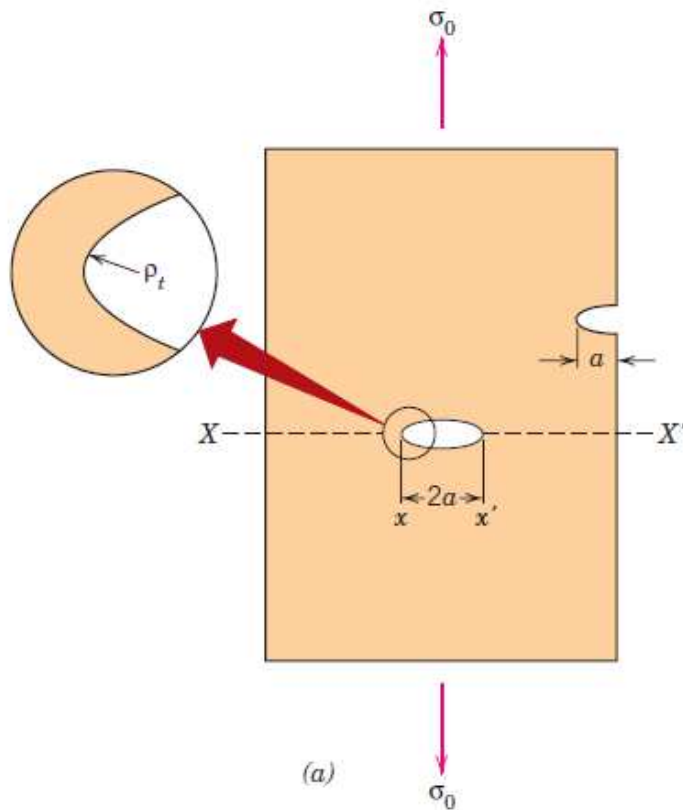

$$\sigma_m = 2\sigma_0 \left( \frac{a}{\rho_t} \right)^{1/2} \quad K_t = \frac{\sigma_m}{\sigma_0} = 2 \left( \frac{a}{\rho_t} \right)^{1/2}$$

# [ Tenacidade à fratura ]

$$\sigma_c = \left( \frac{2E\gamma_s}{\pi a} \right)^{1/2}$$

$$K_c = Y\sigma_c \sqrt{\pi a}$$

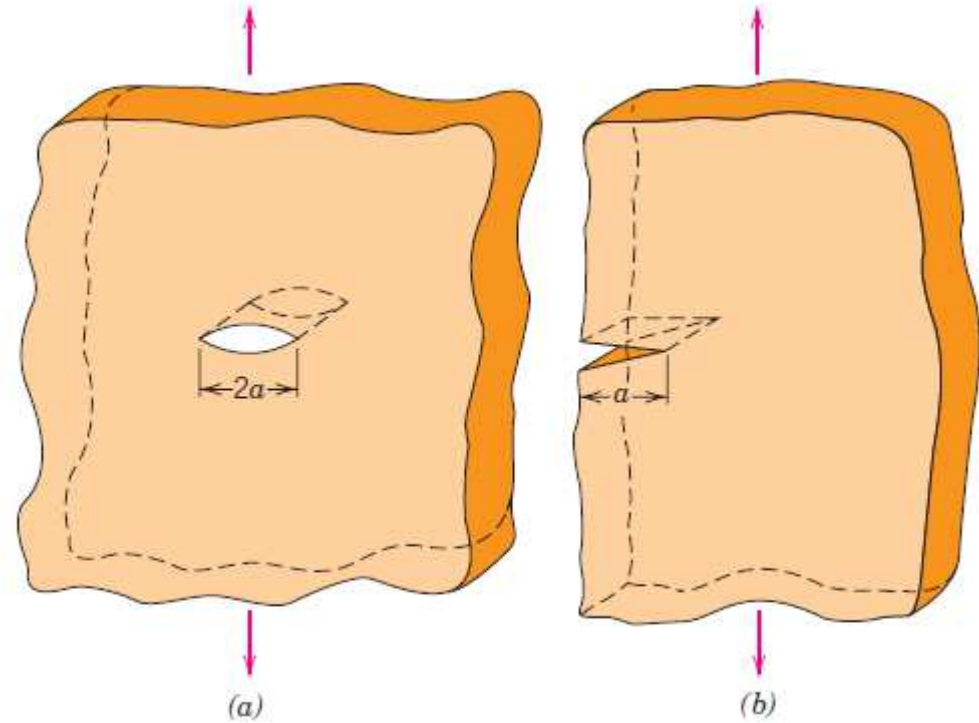

# [ Modos de fratura ]

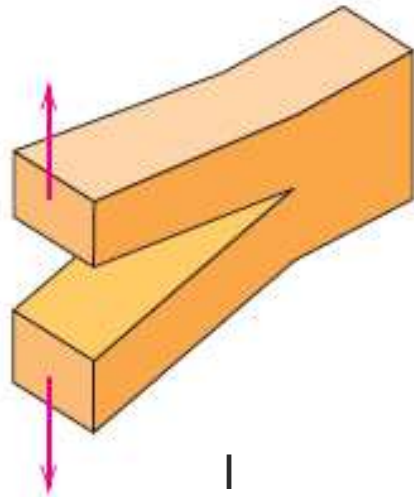

I

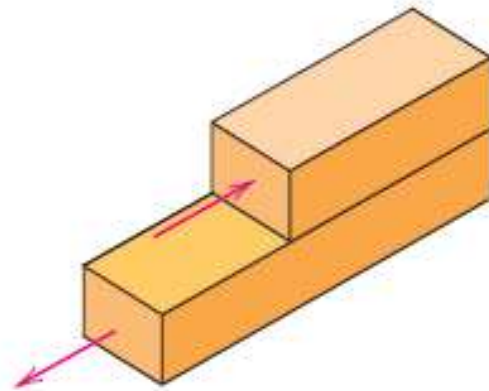

II

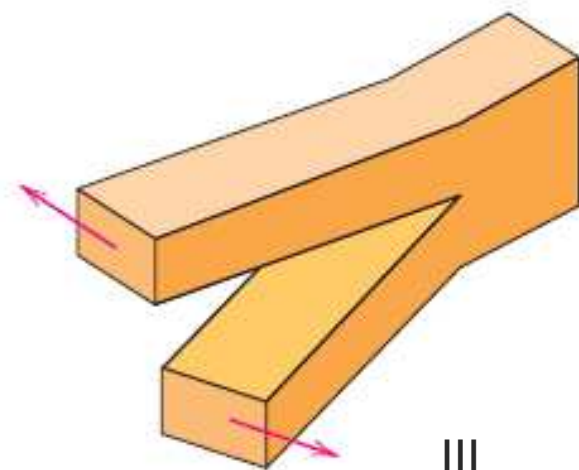

III

$$K_{Ic} = Y\sigma\sqrt{\pi a}$$

# [ Ensaaios de impacto ]

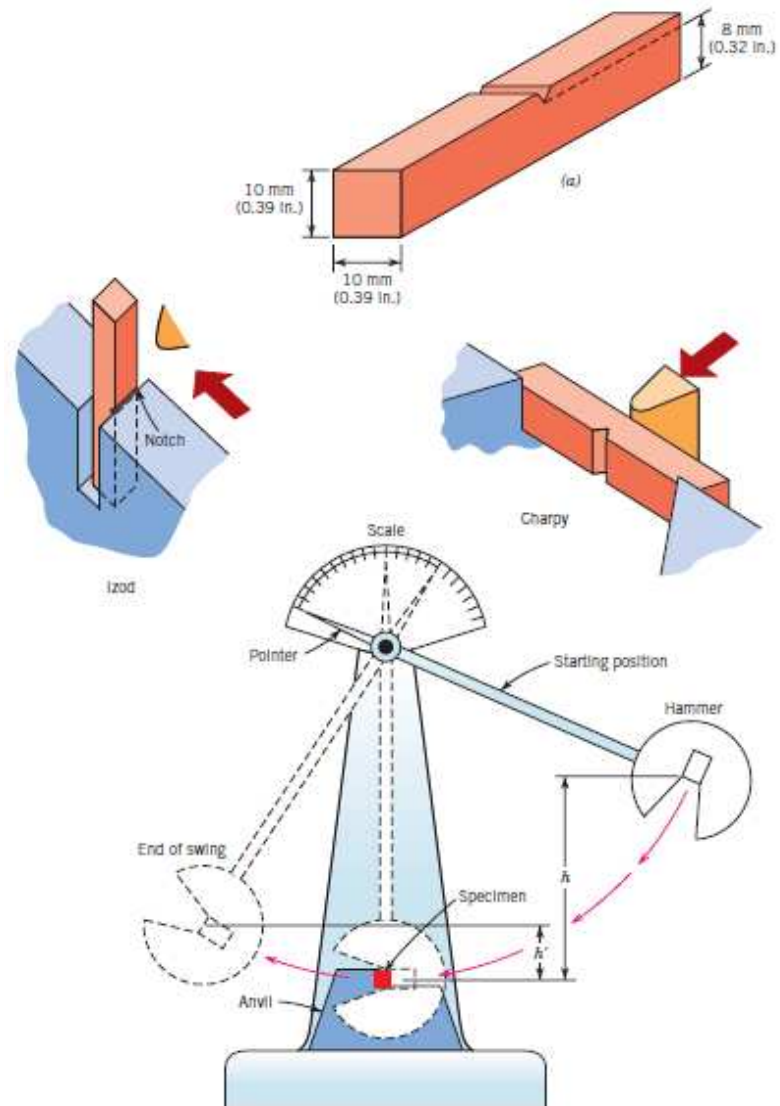

# [ Transição frágil x dúctil ]

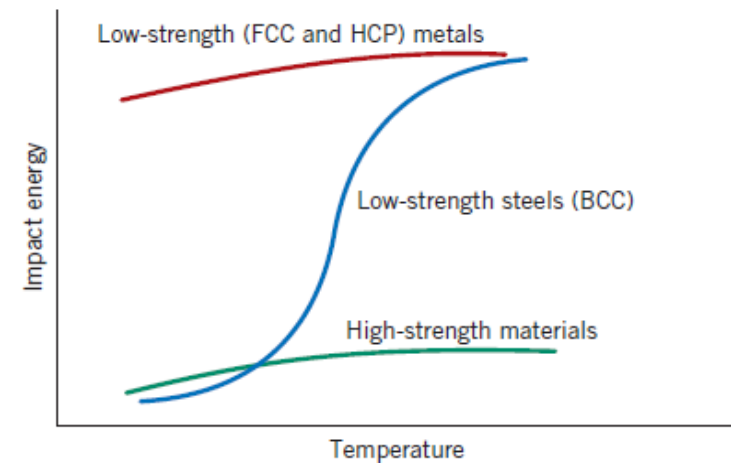
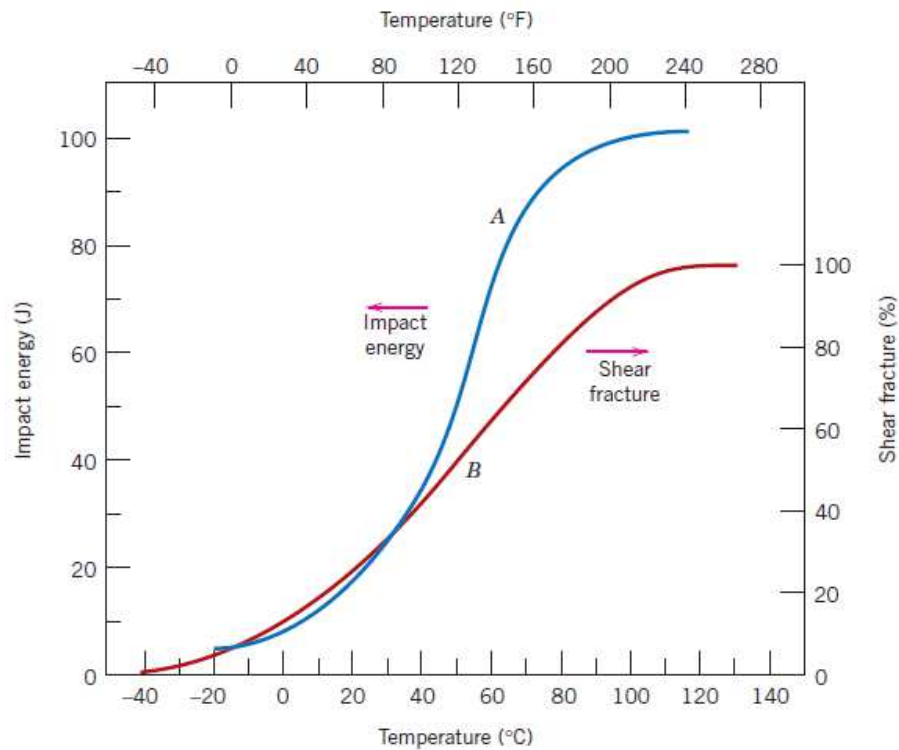



# [ Transição frágil x dúctil ]

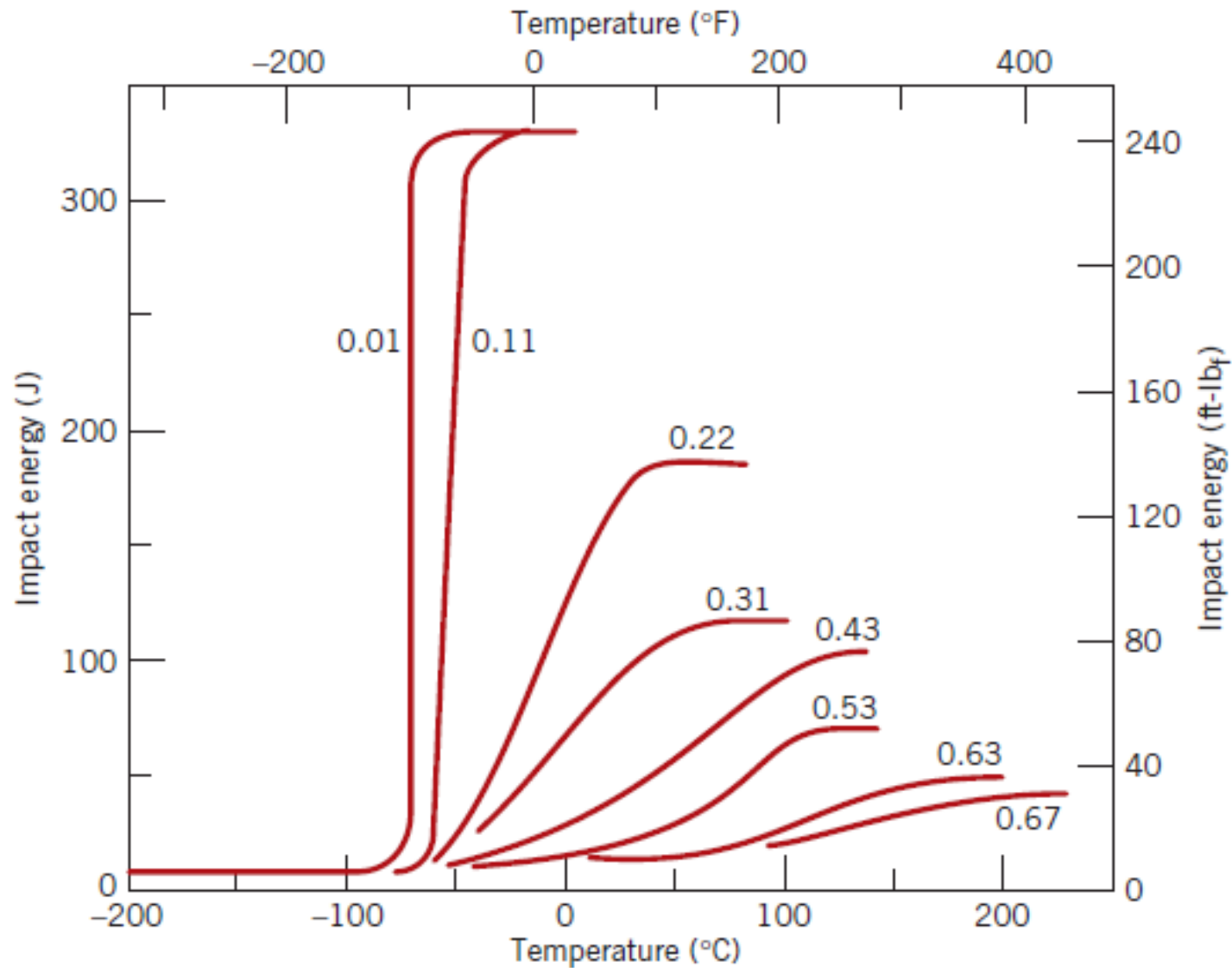

# [ Fadiga ]

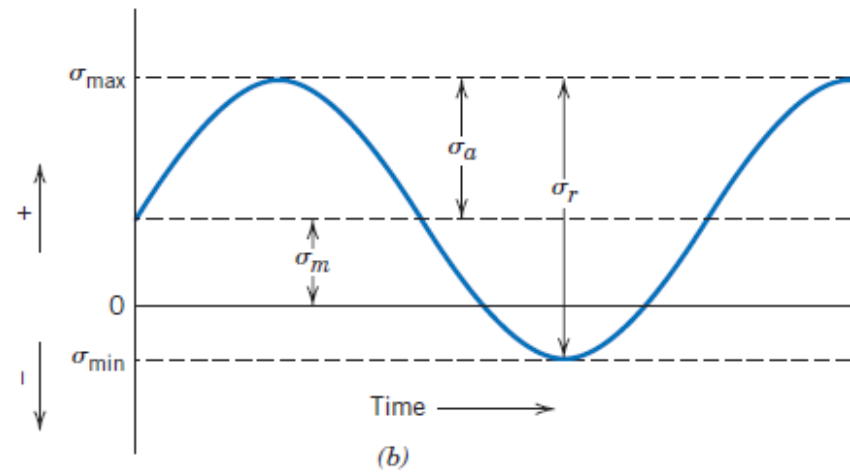
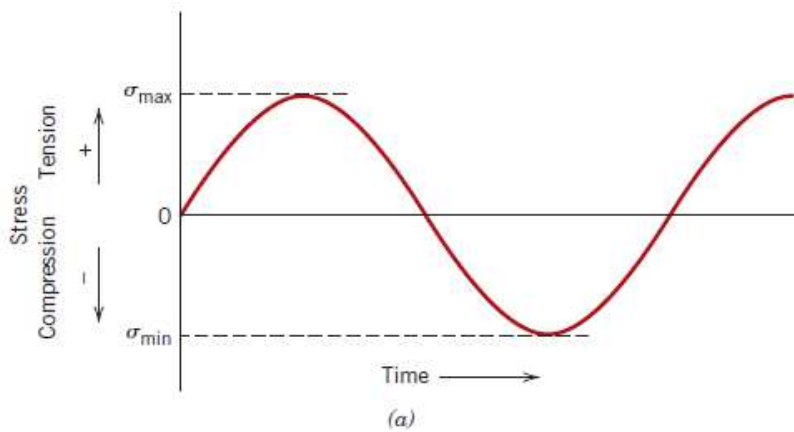
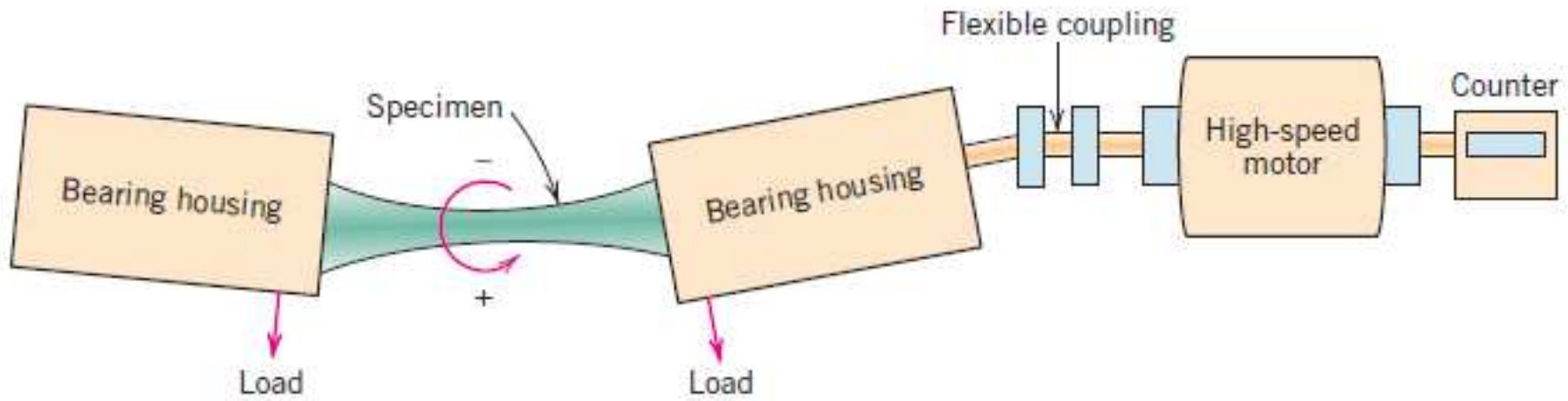

# [ Fadiga ]

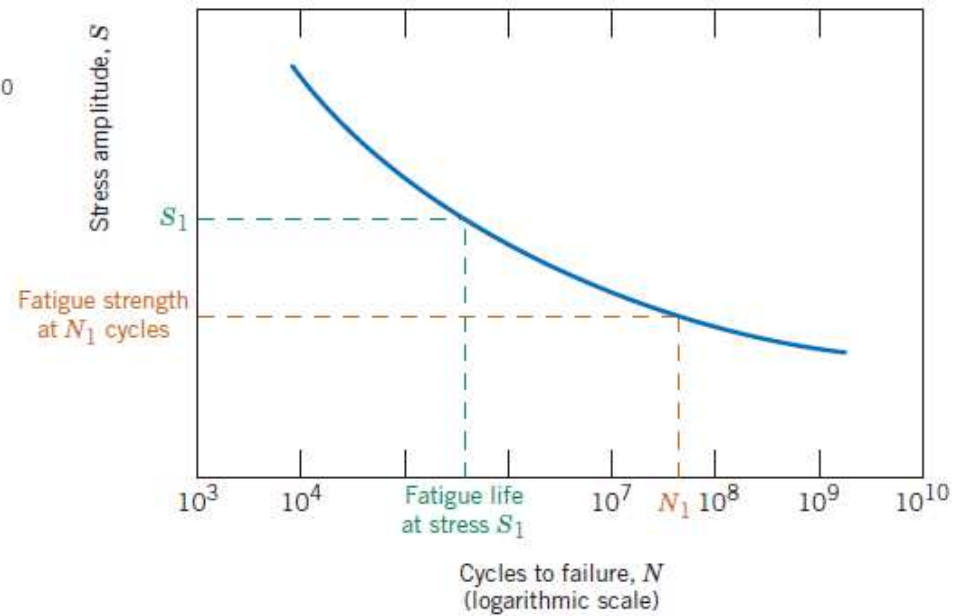
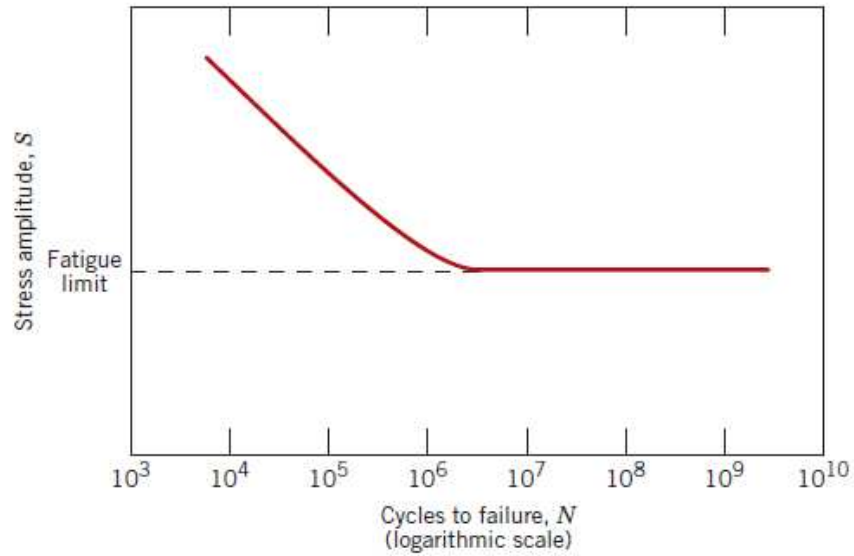

# [ Fadiga ]

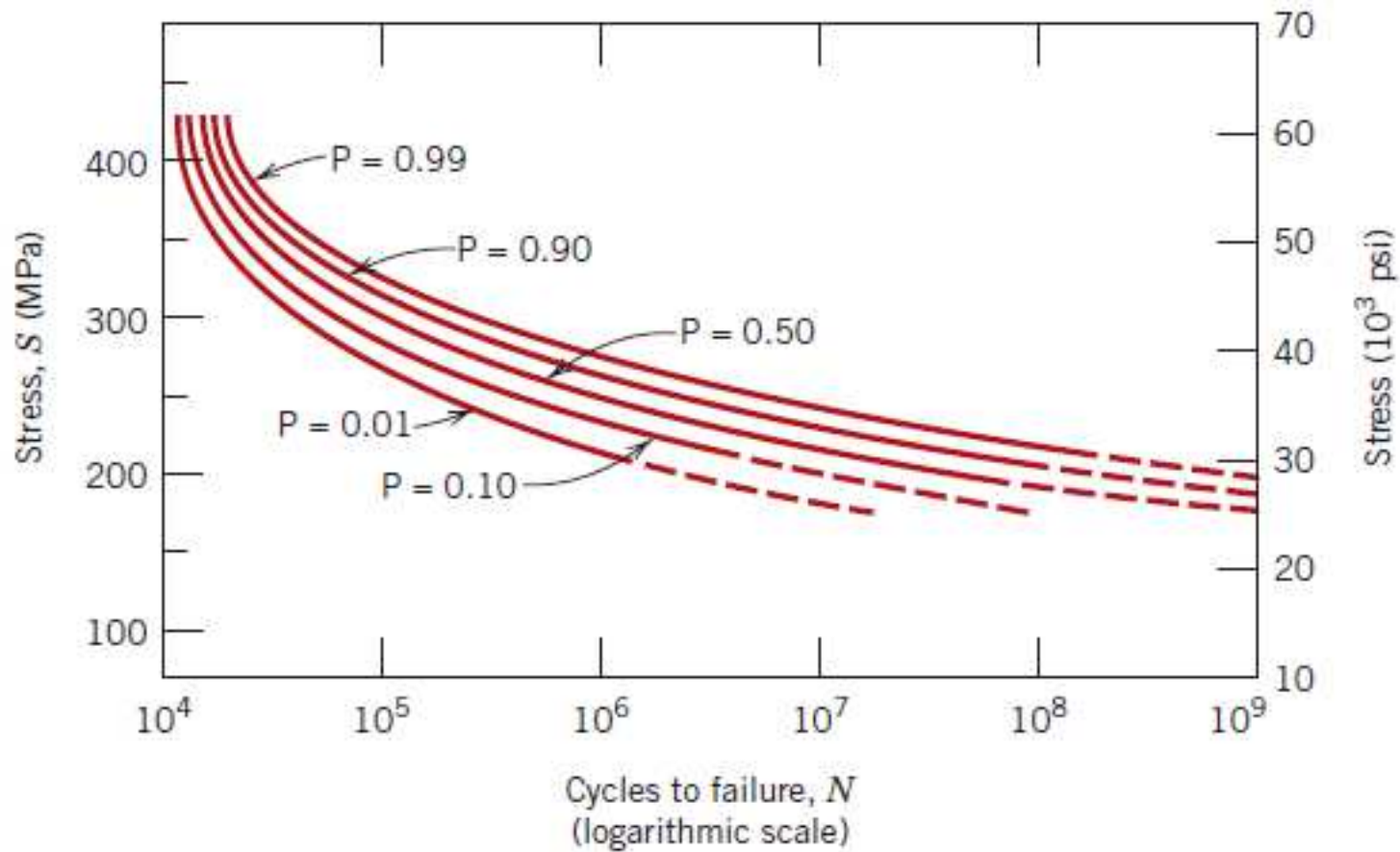

# Nucleação e Propagação da Trinca

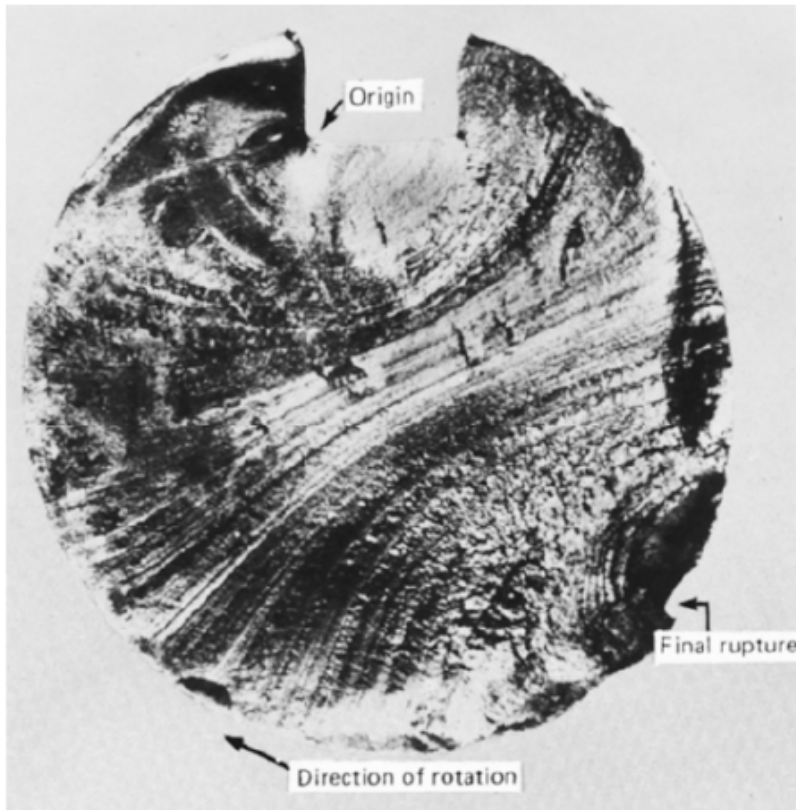

MEV



# [ Fluência ]

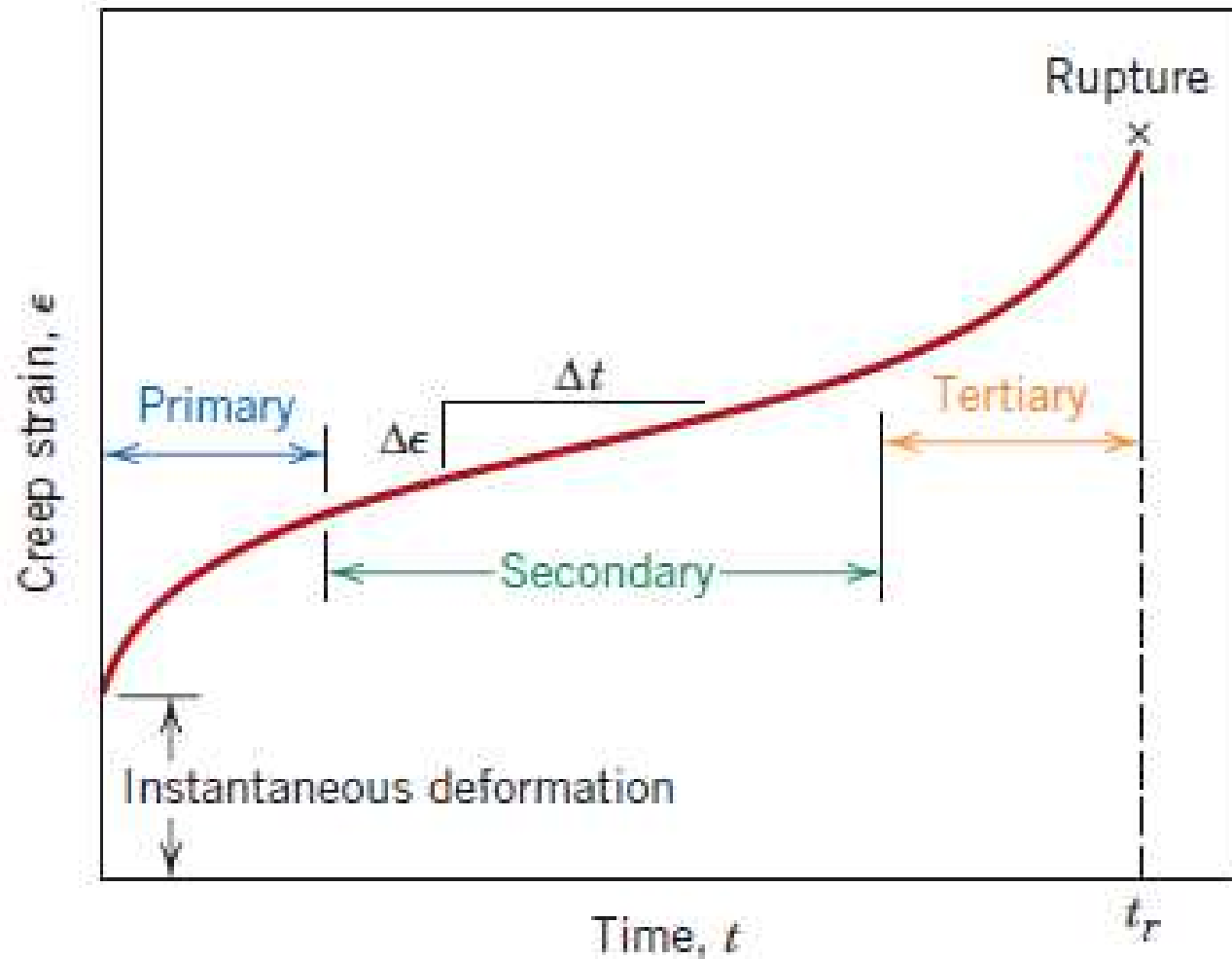

# [ Fluência ]

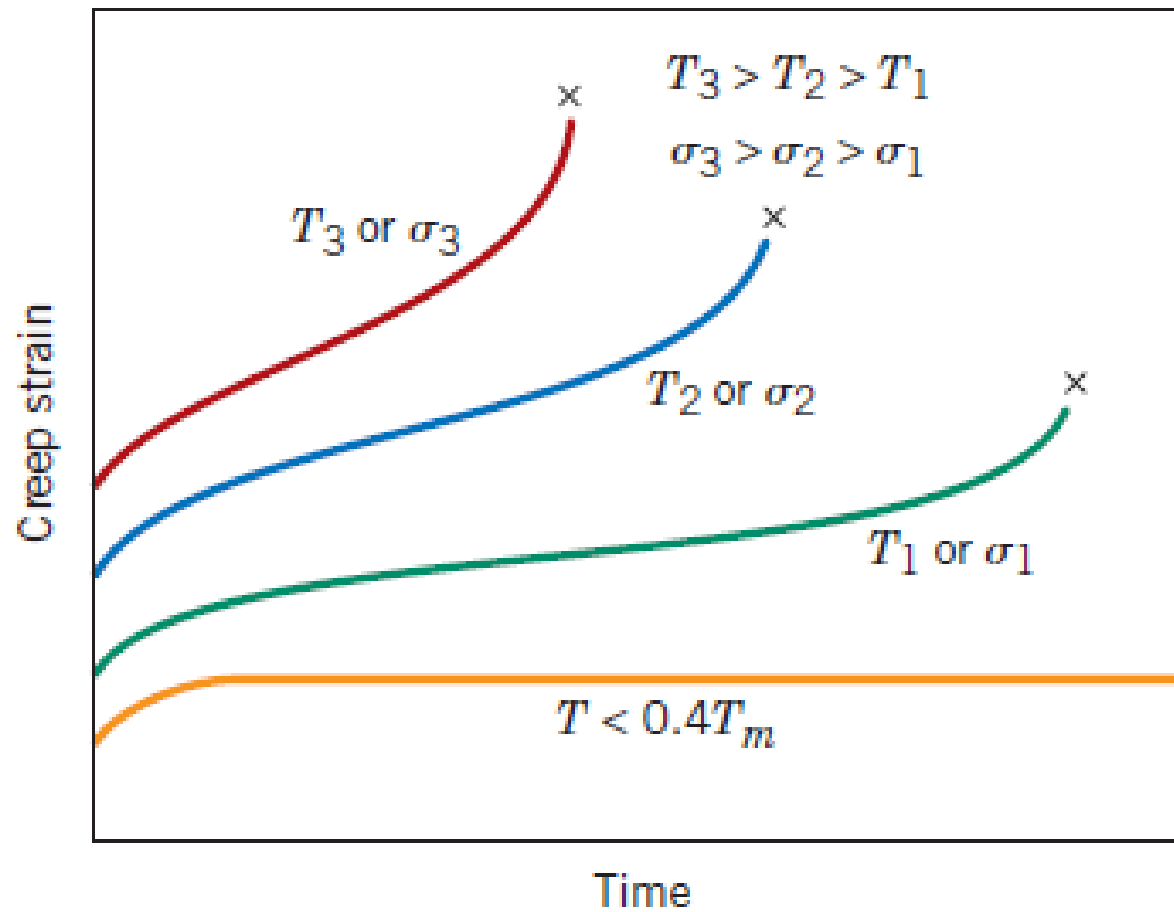

# [ Fluência ]

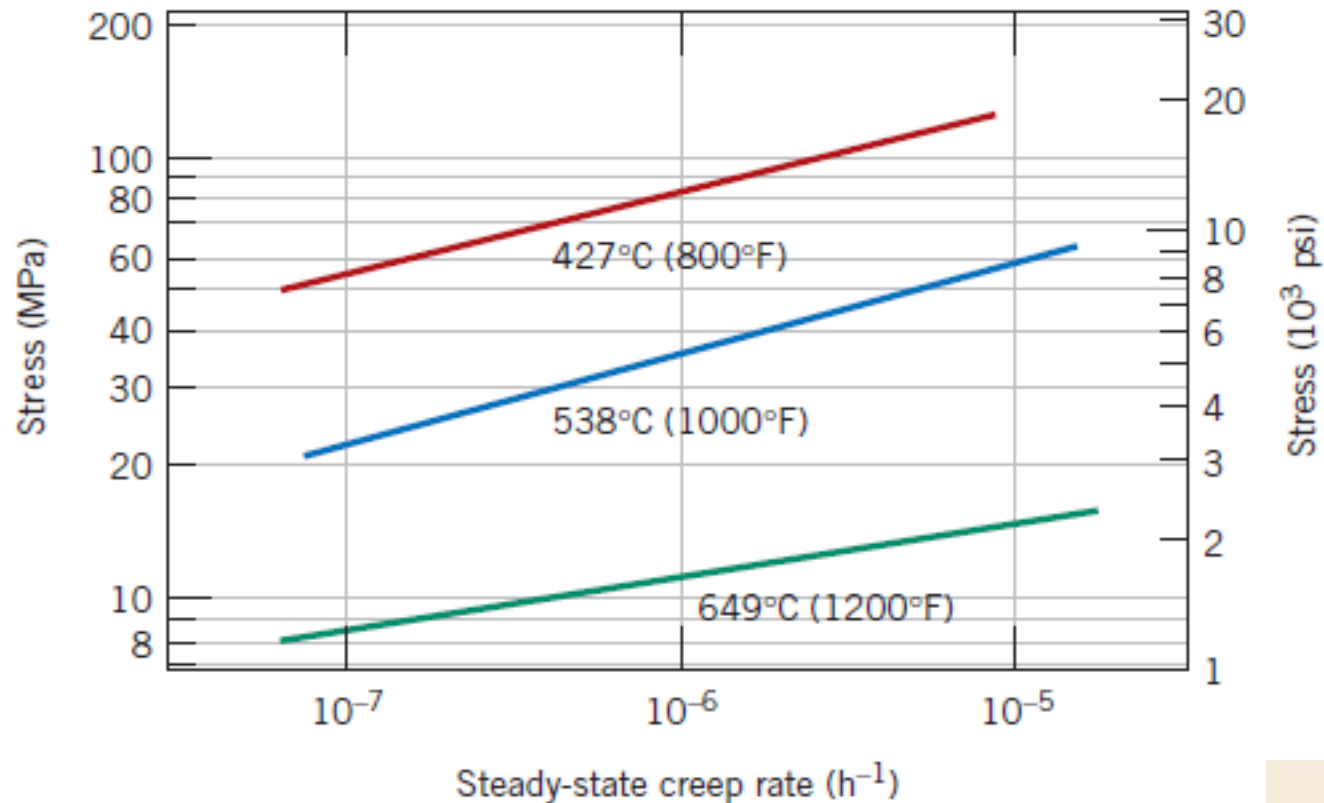

$$\dot{\epsilon}_s = K_1 \sigma^n$$

$$\dot{\epsilon}_s = K_2 \sigma^n \exp\left(-\frac{Q_c}{RT}\right)$$