

Lista de exercícios nº 8

Estruturas associadas

1 - Traçar os diagramas de esforços solicitantes das seguintes estruturas:

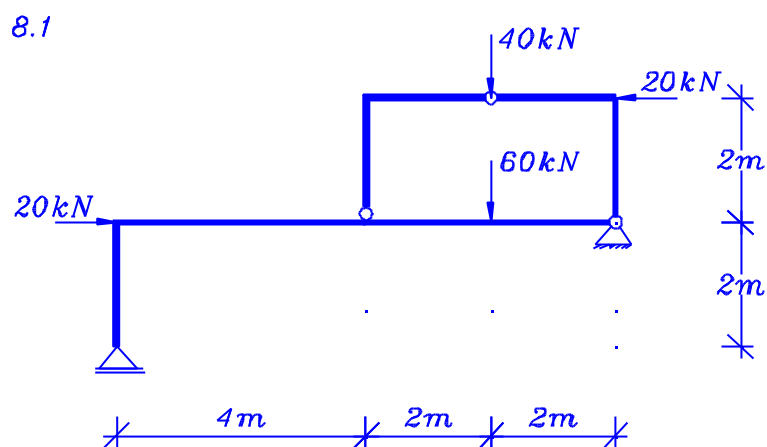

R:

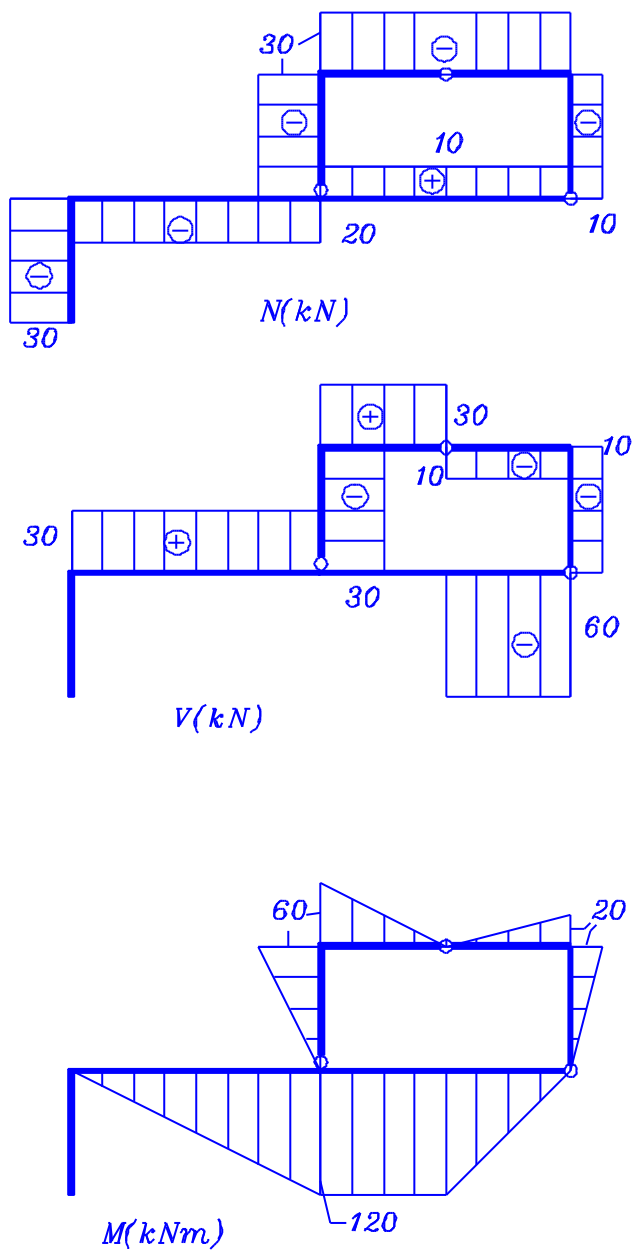

8.2

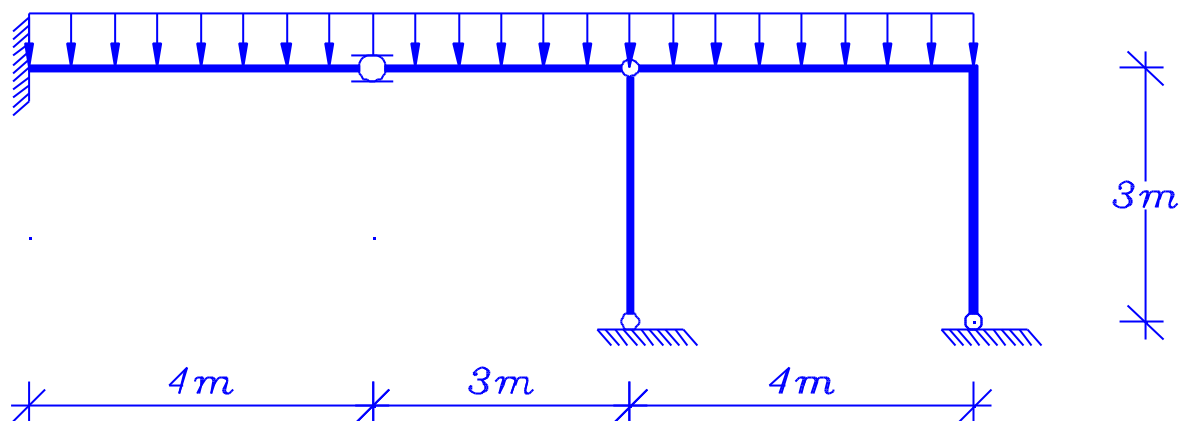
 10 kN/m 

R:

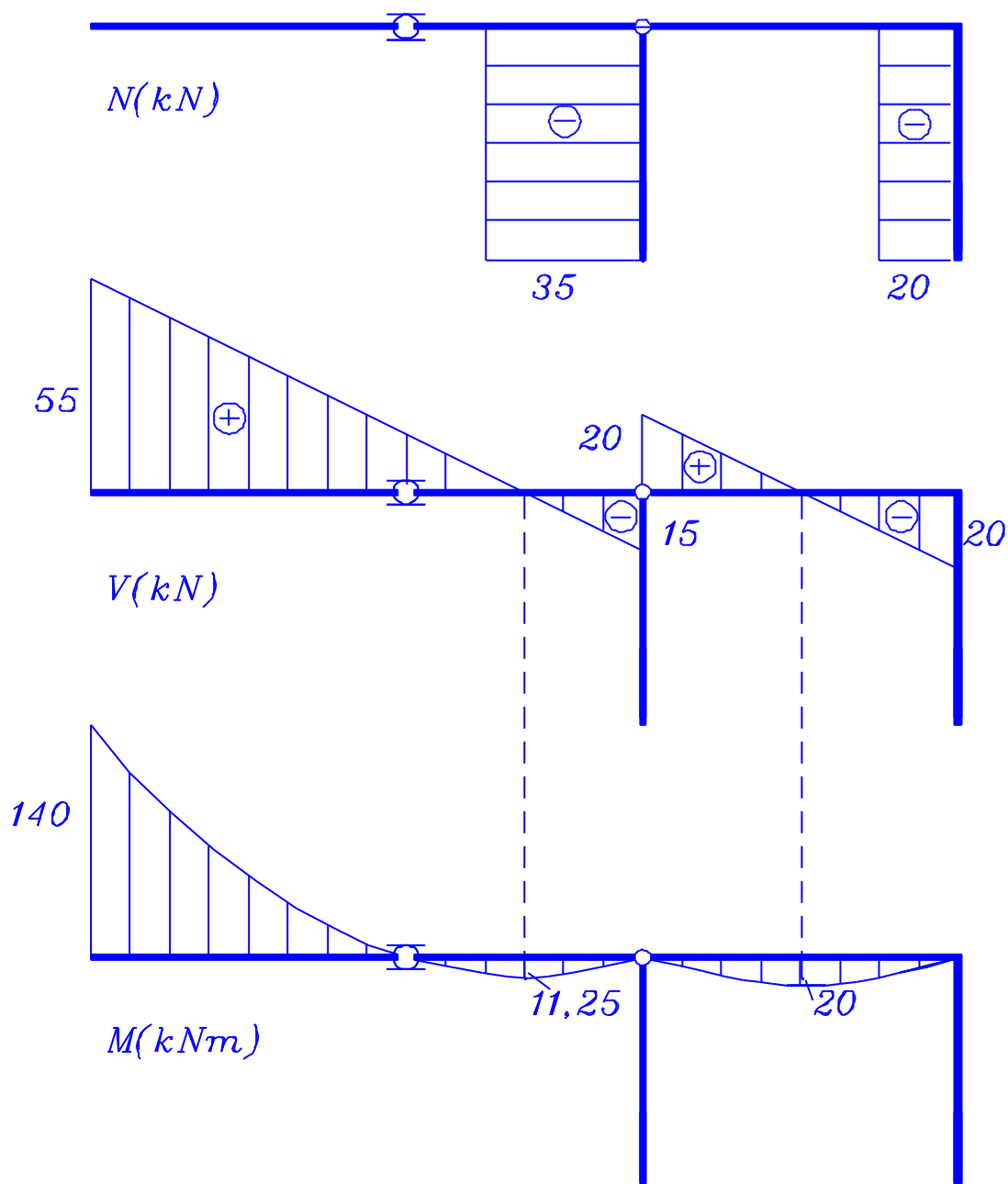

8.3

