

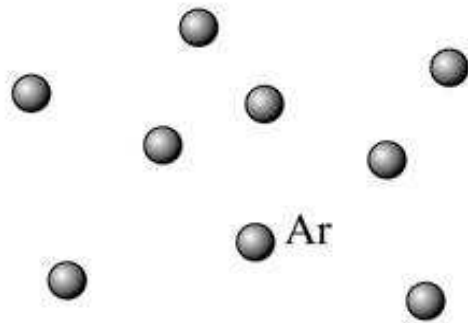

Estruturas Metálicas

- Conceitos Gerais
- Cristais Metálicos

Níveis de organização



(a)

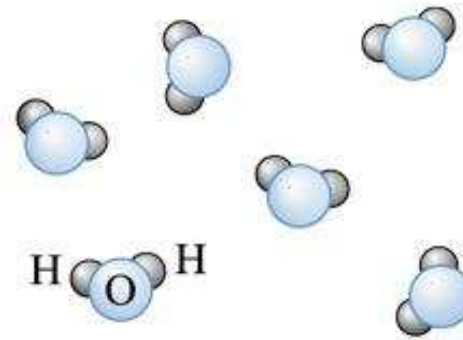

(b)

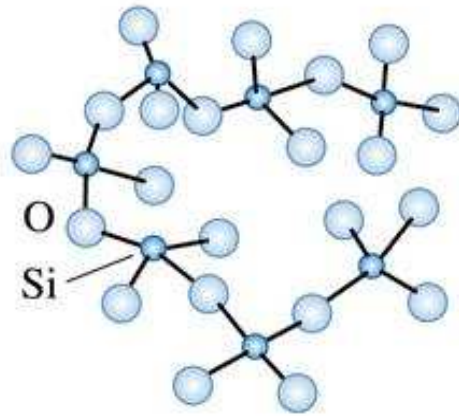

(c)

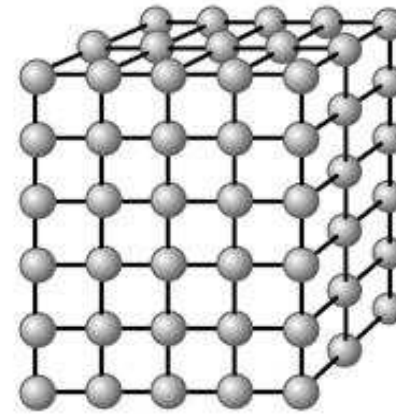

(d)

Curto Alcance

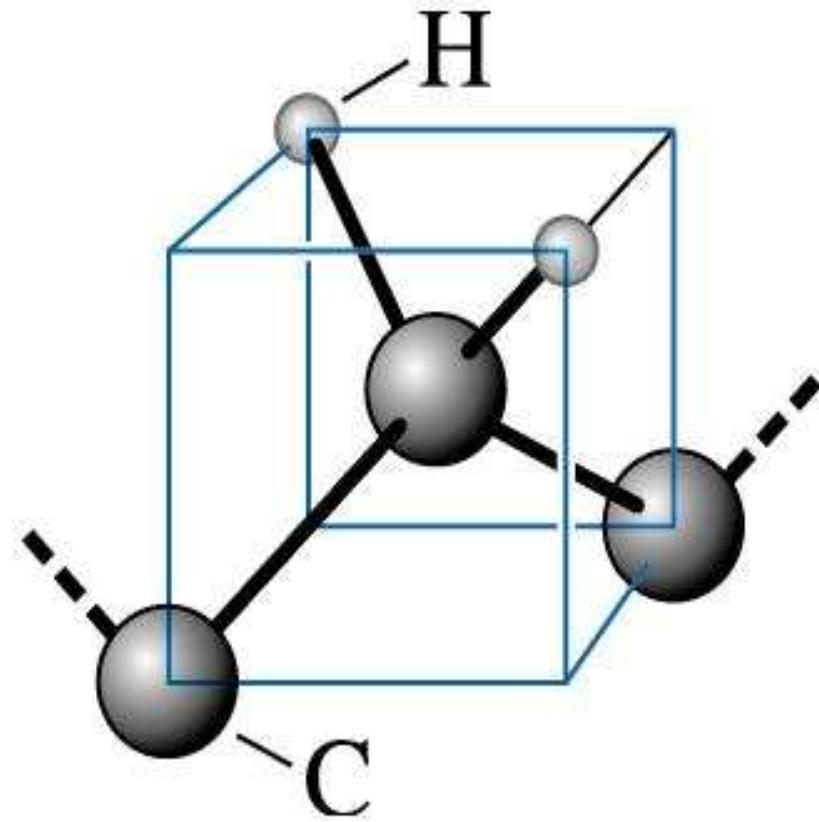
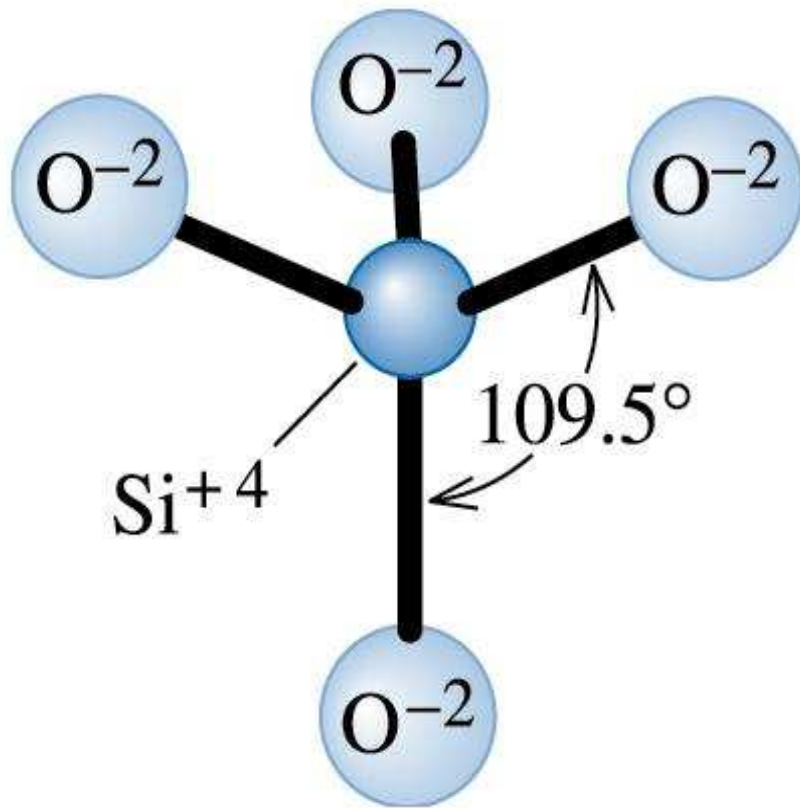

Longo Alcance (Cristais)

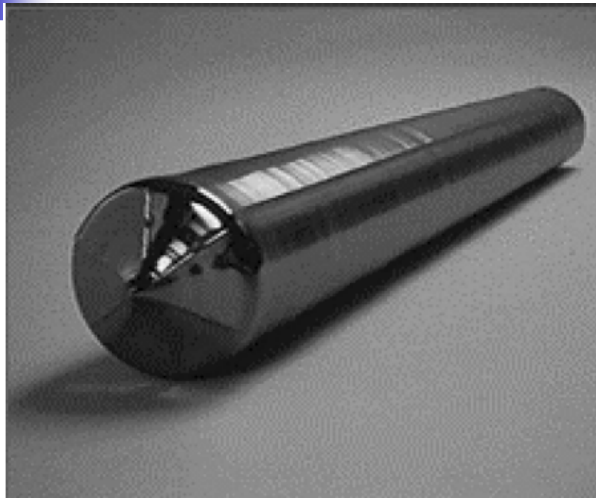

(a)

Monocrital (Si)

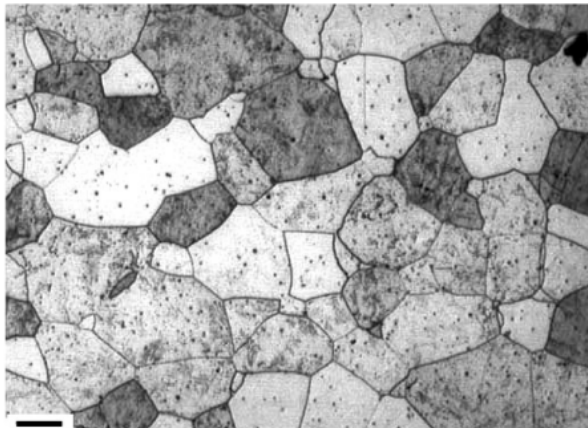

(b)

Material Policristalino (Aço)



Resumo

A: Monoatomic Gases
No Order
Example: Argon gas

B: Amorphous Materials
No Long Range Order
Only Short Range Order
Examples: Amorphous Si,
Glasses, Plastics

C: Liquid Crystals
Short Range Order
and Long Range Order
in Small Volumes
Example: LCD polymers

D: Crystalline Materials
Short and Long
Range Order

Single Crystal
Examples: Si, GaAs

Polycrystalline
Examples: Metals,
Alloys and
Most Ceramics

Amorfo x Cristalino

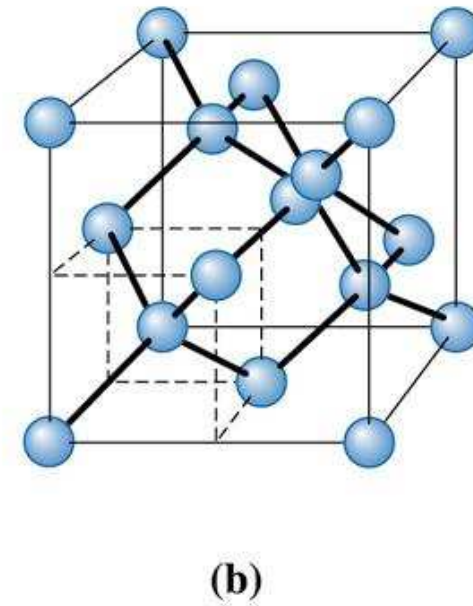
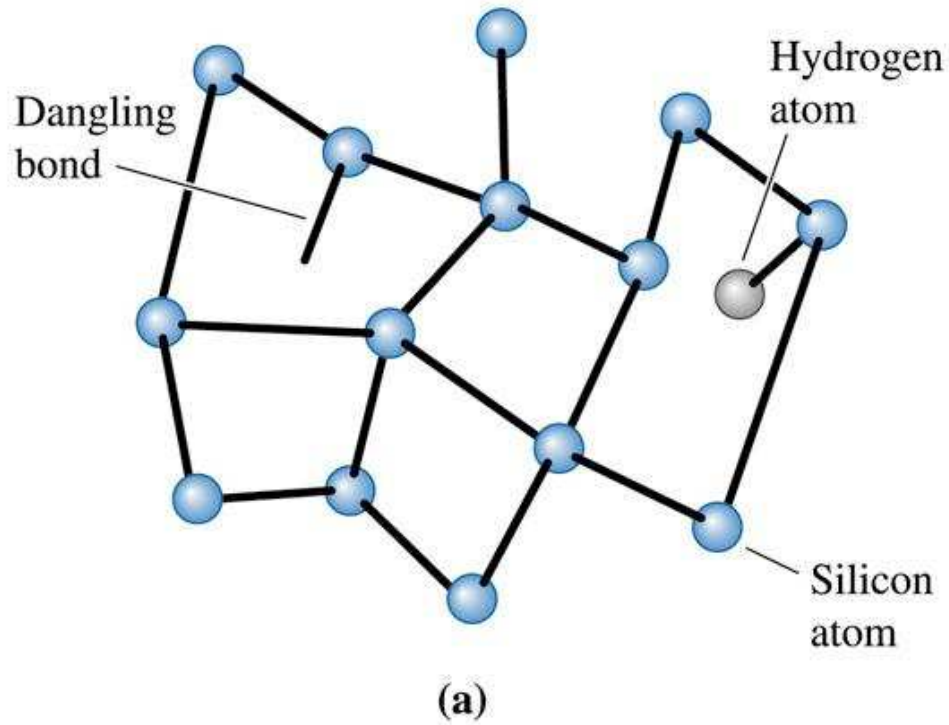

Redes de Bravais

14 Redes
7 Sistemas

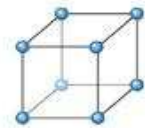

Simple cubic

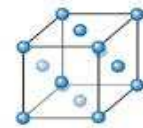

Face-centered cubic

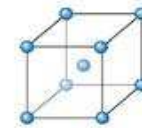

Body-centered cubic

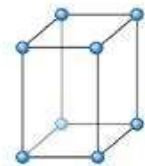

Simple tetragonal

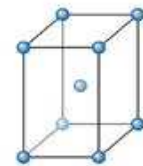

Body-centered tetragonal

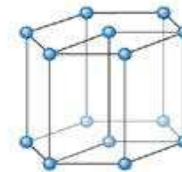

Hexagonal

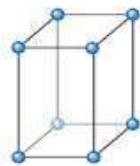

Simple orthorhombic

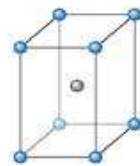

Body-centered orthorhombic

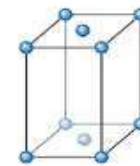

Base-centered orthorhombic

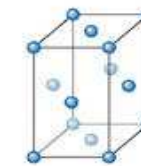

Face-centered orthorhombic

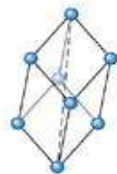

Rhombohedral

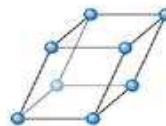

Simple monoclinic

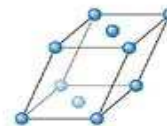

Base-centered monoclinic

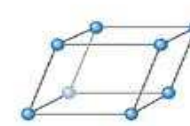

Triclinic



Características geométricas

TABLE 3-1 ■ *Characteristics of the seven crystal systems*

Structure	Axes	Angles between Axes	Volume of the Unit Cell
Cubic	$a = b = c$	All angles equal 90°	a^3
Tetragonal	$a = b \neq c$	All angles equal 90°	a^2c
Orthorhombic	$a \neq b \neq c$	All angles equal 90°	abc
Hexagonal	$a = b \neq c$	Two angles equal 90° . One angle equals 120° .	$0.866a^2c$
Rhombohedral or trigonal	$a = b = c$	All angles are equal and none equals 90°	$a^3\sqrt{1 - 3\cos^2\alpha + 2\cos^3\alpha}$
Monoclinic	$a \neq b \neq c$	Two angles equal 90° . One angle (β) is not equal to 90°	$abc \sin\beta$
Triclinic	$a \neq b \neq c$	All angles are different and none equals 90°	$abc\sqrt{1 - \cos^2\alpha - \cos^2\beta - \cos^2\gamma + 2\cos\alpha\cos\beta\cos\gamma}$

Simetria (grupos de pontos)

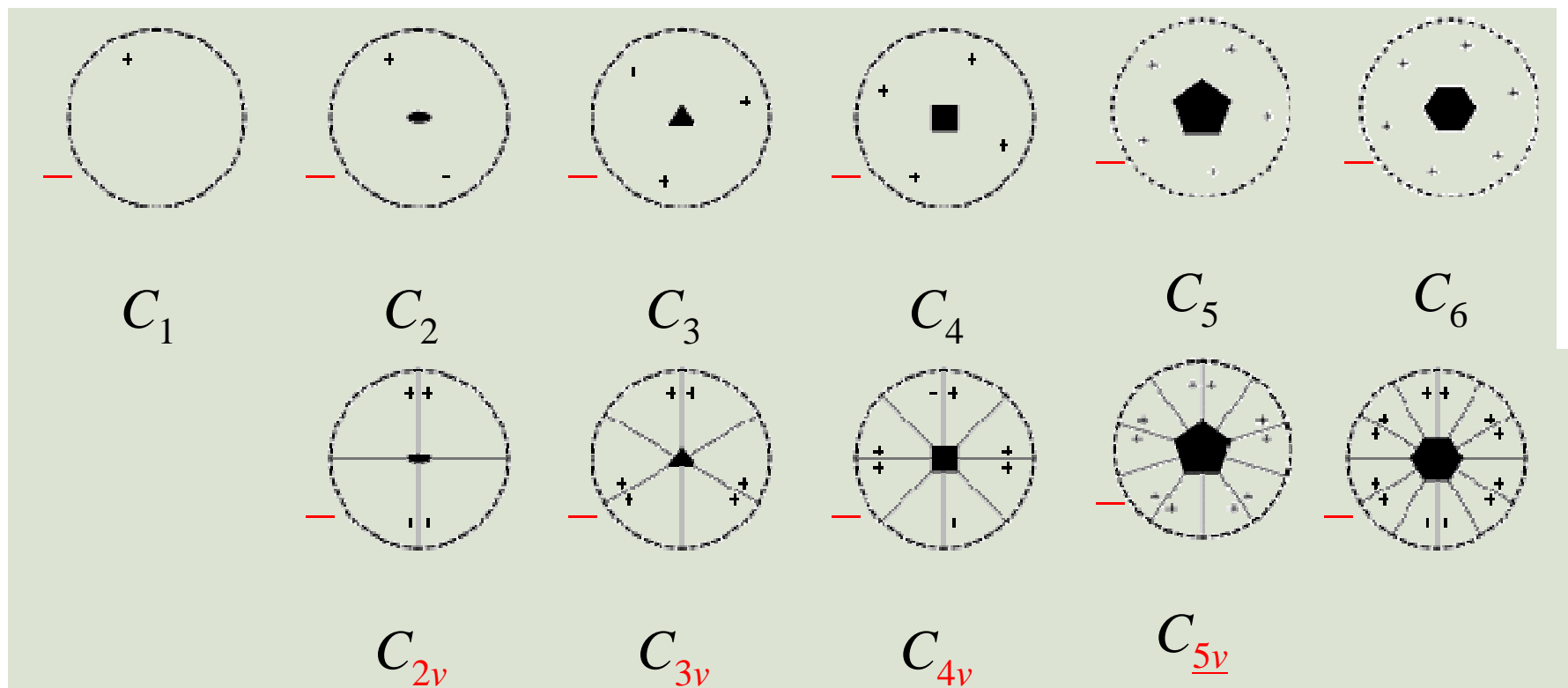



Grupos (pontos, espaciais)

Crystal system	No. of <u>point groups</u>	No. of <u>bravais lattices</u>	No. of <u>space groups</u>
<u>Triclinic</u>	2	1	2
<u>Monoclinic</u>	3	2	13
<u>Orthorhombic</u>	3	4	59
<u>Tetragonal</u>	7	2	68
<u>Rhombohedral</u> (Trigonal)	5	1	25
<u>Hexagonal</u>	7	1	27
<u>Cubic</u>	5	3	36
Total	32	14	230

Crystal system	Point group		#	Space groups (international short symbol)
	Hermann-Mauguin	Schönflies		
Triclinic (2)	1	C ₁	1	P1
	$\bar{1}$	C _i	2	P $\bar{1}$
Monoclinic (13)	2	C ₂	3-5	P2, P2 ₁ , C2
	m	C _s	6-9	Pm, Pc, Cm, Cc
	2/m	C _{2h}	10-15	P2/m, P2 ₁ /m, C2/m, P2/c, P2 ₁ /c, C2/c
Orthorhombic (59)	222	D ₂	16-24	P222, P222 ₁ , P2 ₁ 2 ₁ 2, P2 ₁ 2 ₁ 2 ₁ , C222 ₁ , C222, F222, I222, I2 ₁ 2 ₁ 2 ₁
	mm2	C _{2v}	25-46	Pmm2, Pmc2 ₁ , Pcc2, Pma2, Pca2 ₁ , Pnc2, Pmn2 ₁ , Pba2, Pna2 ₁ , Pnn2, Cmm2, Cmc2 ₁ , Ccc2, Amm2, Aem2, Ama2, Aea2, Fmm2, Fdd2, Imm2, Iba2, Ima2
	mmm	D _{2h}	47-74	Pmmm, Pnnn, Pccm, Pban, Pmma, Pnna, Pmna, Pcca, Pbam, Pccn, Pbcm, Pnnm, Pmmn, Pbcn, Pbca, Pnma, Cmcm, Cmce, Cmmm, Cccm, Cmme, Ccce, Fmmm, Fddd, Immm, Ibam, Ibca, Imma
Tetragonal (68)	4	C ₄	75-80	P4, P4 ₁ , P4 ₂ , P4 ₃ , I4, I4 ₁
	$\bar{4}$	S ₄	81-82	P $\bar{4}$, I $\bar{4}$
	$\bar{4}/m$	C _{4h}	83-88	P4/m, P4 ₂ /m, P4/n, P4 ₂ /n, I4/m, I4 ₁ /a
	422	D ₄	89-98	P422, P4 ₂ 12, P4 ₁ 22, P4 ₁ 2 ₁ 2, P4 ₂ 22, P4 ₂ 2 ₁ 2, P4 ₃ 22, P4 ₃ 2 ₁ 2, I422, I4 ₁ 22
	4mm	C _{4v}	99-110	P4mm, P4bm, P4 ₂ cm, P4 ₂ nm, P4cc, P4nc, P4 ₂ mc, P4 ₂ bc, I4mm, I4cm, I4 ₁ md, I4 ₁ cd
	$\bar{4}2m$	D _{2d}	111-122	P $\bar{4}2m$, P $\bar{4}2c$, P $\bar{4}2_1m$, P $\bar{4}2_1c$, P $\bar{4}m2$, P $\bar{4}c2$, P $\bar{4}b2$, P $\bar{4}n2$, I $\bar{4}m2$, I $\bar{4}c2$, I $\bar{4}2m$, I $\bar{4}2d$
	4/mmm	D _{4h}	123-142	P4/mmm, P4/mcc, P4/nbm, P4/nnc, P4/mbm, P4/mnc, P4/nmm, P4/ncc, P4 ₂ /mmc, P4 ₂ /mcm, P4 ₂ /nbc, P4 ₂ /nmm, P4 ₂ /mbc, P4 ₂ /mnm, P4 ₂ /nmc, P4 ₂ /ncm, I4/mmm, I4/mcm, I4 ₁ /amd, I4 ₁ /acd
Trigonal (25)	3	C ₃	143-146	P3, P3 ₁ , P3 ₂ , R3
	$\bar{3}$	S ₆	147-148	P $\bar{3}$, R $\bar{3}$
	32	D ₃	149-155	P312, P321, P3 ₁ 12, P3 ₁ 21, P3 ₂ 12, P3 ₂ 21, R32
	3m	C _{3v}	156-161	P3m1, P31m, P3c1, P31c, R3m, R3c
	$\bar{3}m$	D _{3d}	162-167	P $\bar{3}1m$, P $\bar{3}1c$, P $\bar{3}m1$, P $\bar{3}c1$, R $\bar{3}m$, R $\bar{3}c$,
Hexagonal (27)	6	C ₆	168-173	P6, P6 ₁ , P6 ₅ , P6 ₂ , P6 ₄ , P6 ₃
	$\bar{6}$	C _{3h}	174	P $\bar{6}$
	6/m	C _{6h}	175-176	P6/m, P6 ₃ /m
	622	D ₆	177-182	P622, P6 ₁ 22, P6 ₅ 22, P6 ₂ 22, P6 ₄ 22, P6 ₃ 22
	6mm	C _{6v}	183-186	P6mm, P6cc, P6 ₃ cm, P6 ₃ mc
	$\bar{6}m2$	D _{3h}	187-190	P $\bar{6}m2$, P $\bar{6}c2$, P $\bar{6}2m$, P $\bar{6}2c$
	6/mmm	D _{6h}	191-194	P6/mmm, P6/mcc, P6 ₃ /mcm, P6 ₃ /mmc
Cubic (36)	23	T	195-199	P23, F23, I23, P2 ₁ 3, I2 ₁ 3
	m $\bar{3}$	T _h	200-206	Pm $\bar{3}$, Pn $\bar{3}$, Fm $\bar{3}$, Fd $\bar{3}$, Im $\bar{3}$, Pa $\bar{3}$, Ia $\bar{3}$
	432	O	207-214	P432, P4 ₂ 32, F432, F4 ₁ 32, I432, P4 ₃ 32, P4 ₁ 32, I4 ₁ 32
	$\bar{4}3m$	T _d	215-220	P $\bar{4}3m$, F $\bar{4}3m$, I $\bar{4}3m$, P $\bar{4}3n$, F $\bar{4}3c$, I $\bar{4}3d$
	m $\bar{3}m$	O _h	221-230	Pm $\bar{3}m$, Pn $\bar{3}n$, Pm $\bar{3}n$, Pn $\bar{3}m$, Fm $\bar{3}m$, Fm $\bar{3}c$, Fd $\bar{3}m$, Fd $\bar{3}c$, Im $\bar{3}m$, Ia $\bar{3}d$

Associando átomos a uma rede em estruturas metálicas

Face center atom
shared between
two unit cells

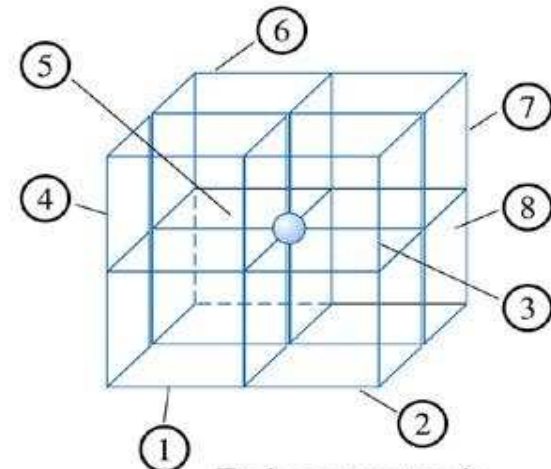
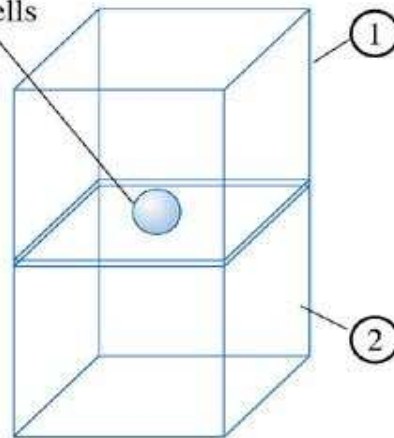

Each corner atom is
shared by 8 unit cells
(1-4 in front, 5-8 in back)

(a)

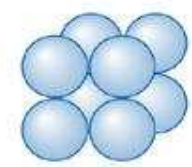

Simple cubic

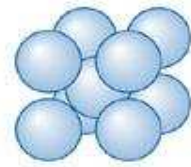

Body-centered
cubic

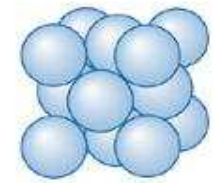

Face-centered
cubic

(b)



Fator de Empacotamento

TABLE 3-2 ■ *Crystal structure characteristics of some metals*

Structure	a_0 versus r	Atoms per Cell	Coordination Number	Packing Factor	Examples
Simple cubic (SC)	$a_0 = 2r$	1	6	0.52	Polonium (Po), α -Mn
Body-centered cubic	$a_0 = 4r/\sqrt{3}$	2	8	0.68	Fe, Ti, W, Mo, Nb, Ta, K, Na, V, Zr, Cr
Face-centered cubic	$a_0 = 4r/\sqrt{2}$	4	12	0.74	Fe, Cu, Au, Pt, Ag, Pb, Ni
Hexagonal close-packed	$a_0 = 2r$ $c_0 \approx 1.633a_0$	2	12	0.74	Ti, Mg, Zn, Be, Co, Zr, Cd

Demonstrar exemplo de cálculo

Direções

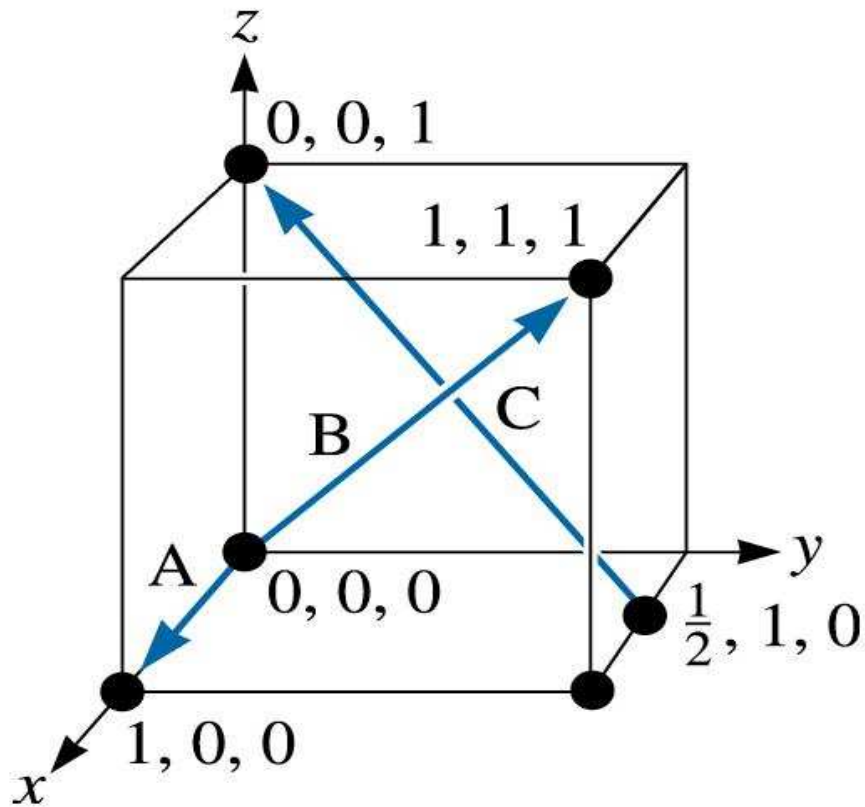

Notação empregada:
Índices de Miller
[hkl] e <hkl>

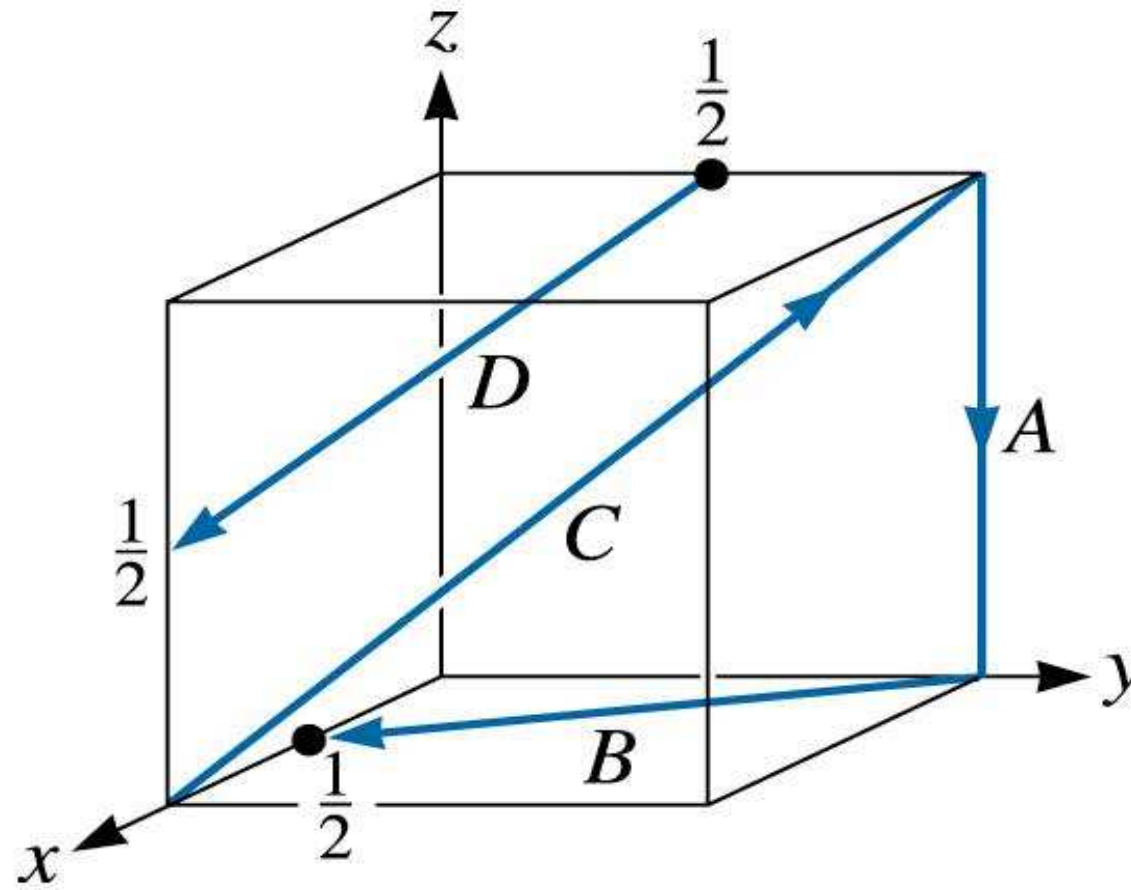
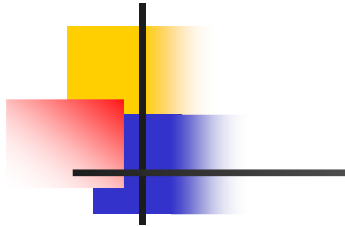

(c) 2003 Brooks/Cole Publishing / Thomson Learning

Figure 3.48 Directions in a cubic unit cell for Problem 3.51

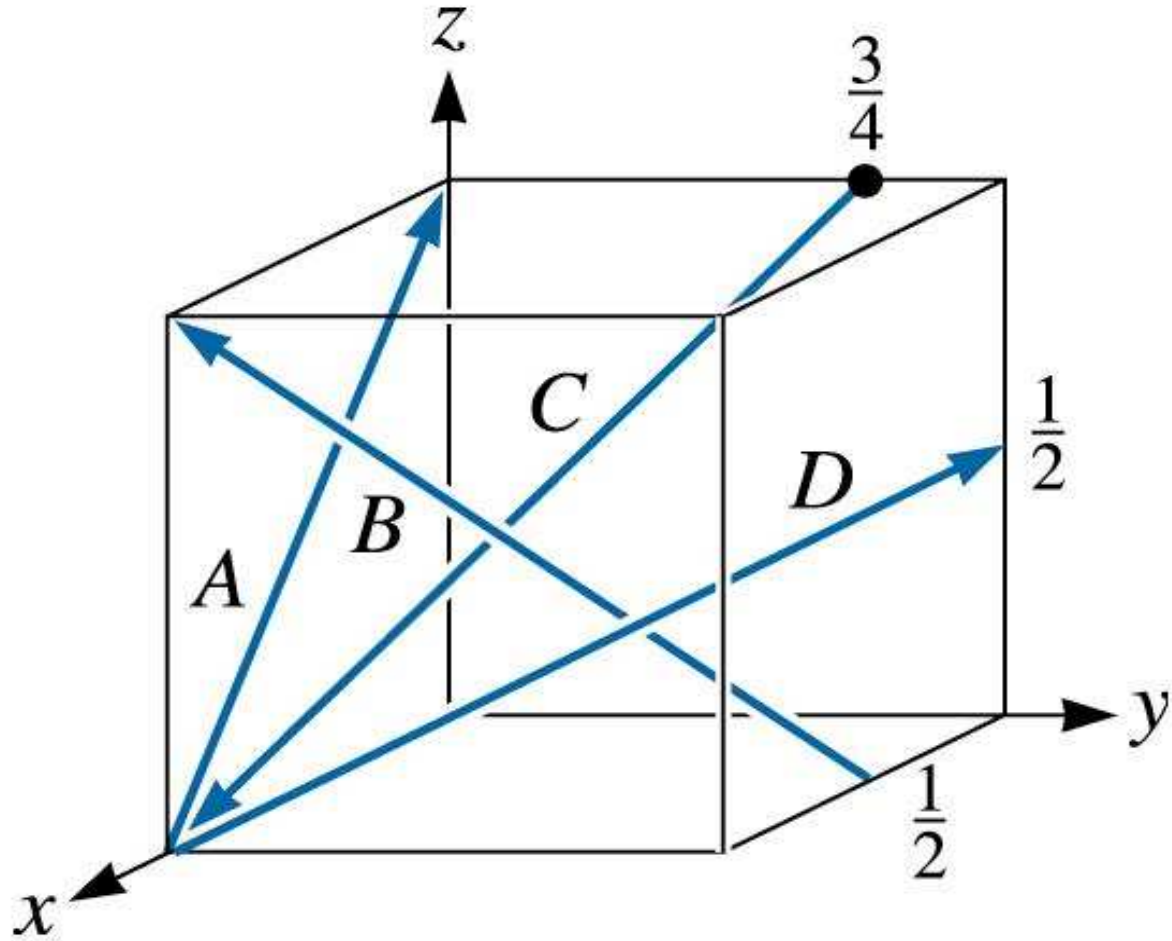

Figure 3.49
Directions in a cubic
unit cell for Problem
3.52.



Densidade Linear

- Exemplo

Planos

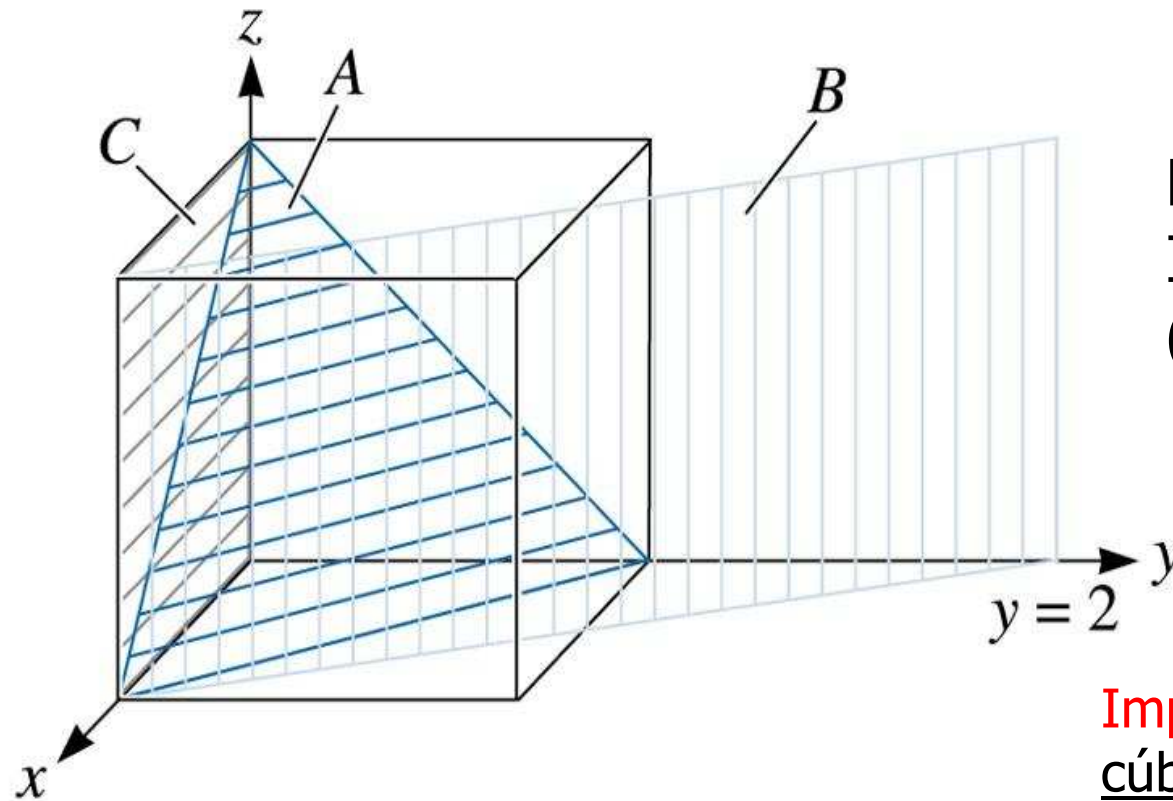

Notação empregada:
Índices de Miller
(hkl) e {hkl}

Exemplos: CCC e CFC

Importante: no sistema
cúbico as direções [hkl] são
perpendiculares aos planos
(hkl)

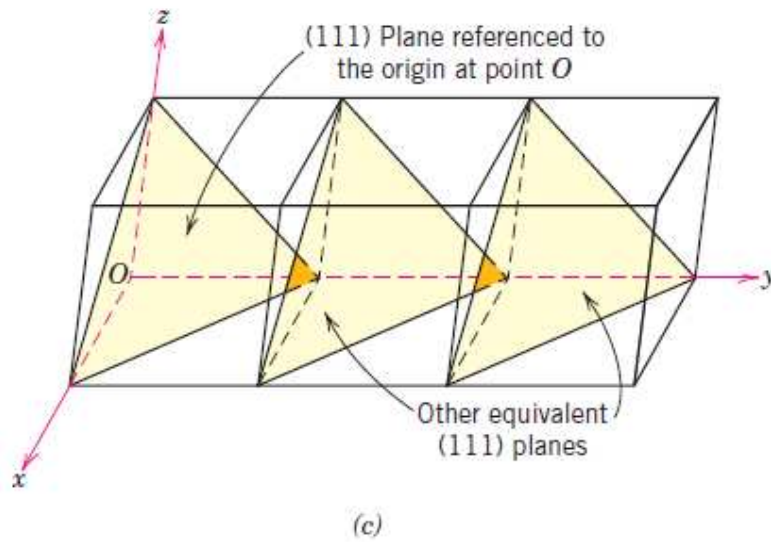
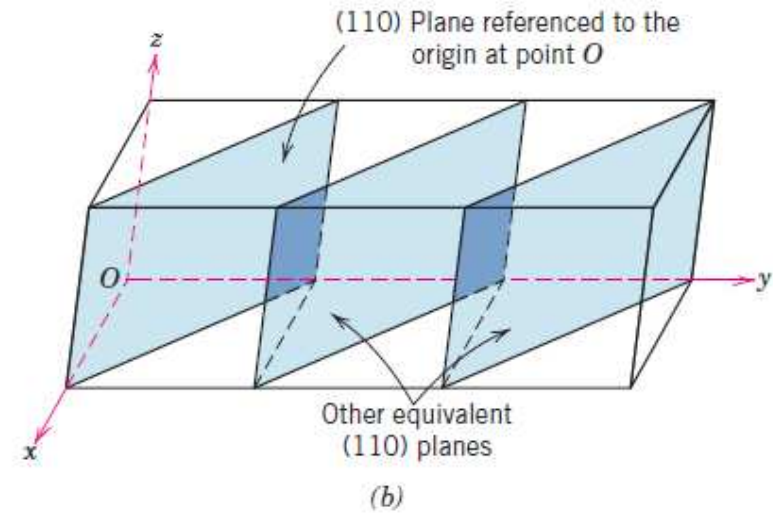
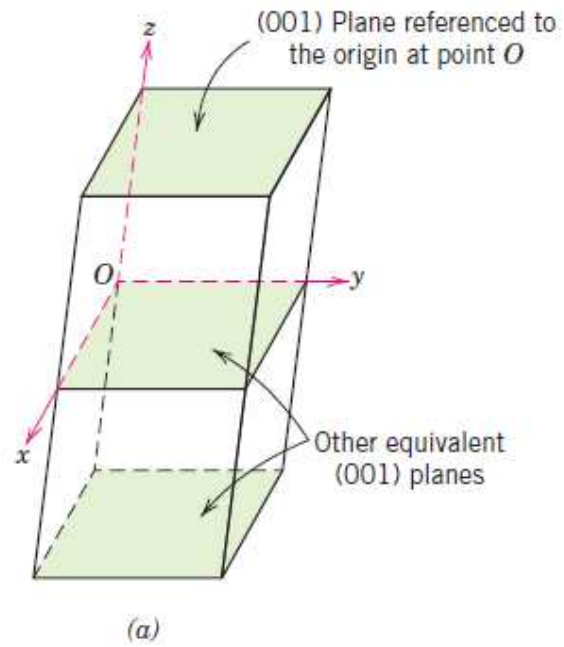
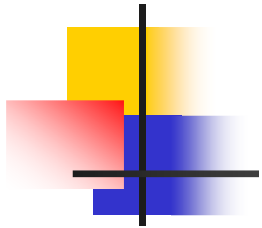

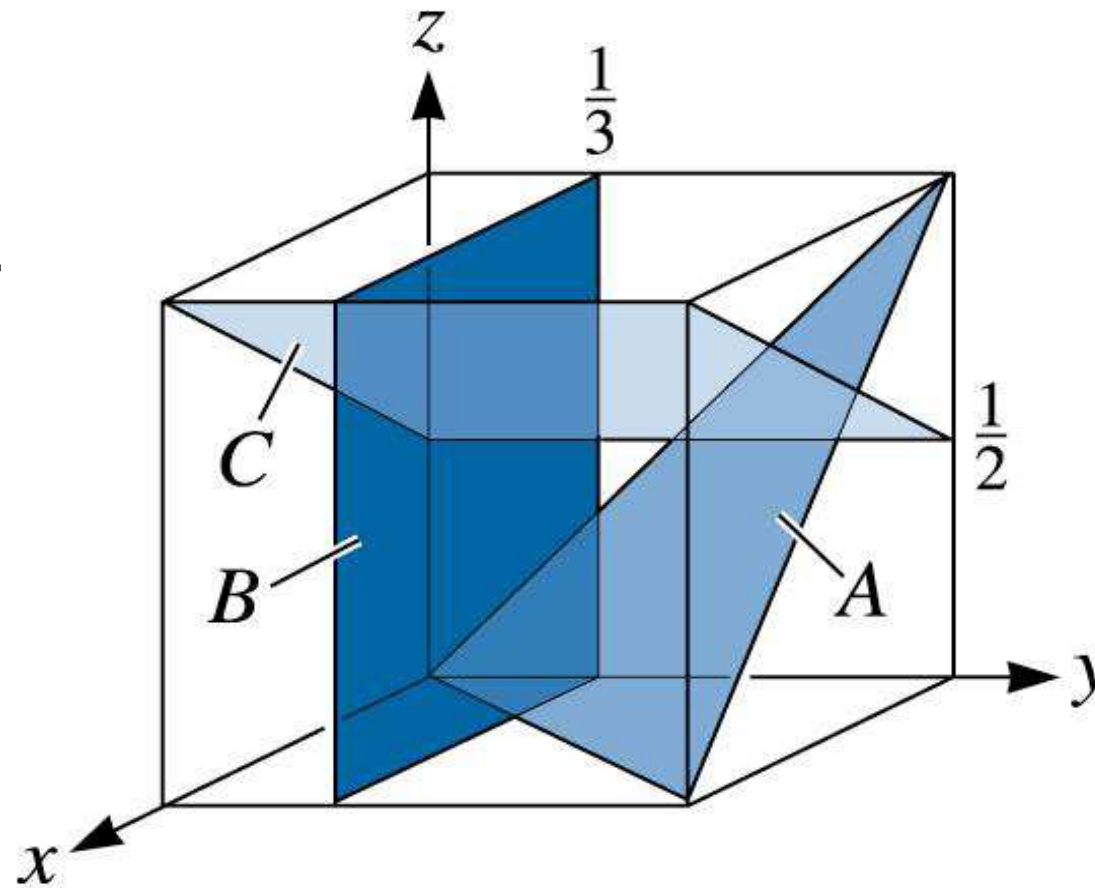
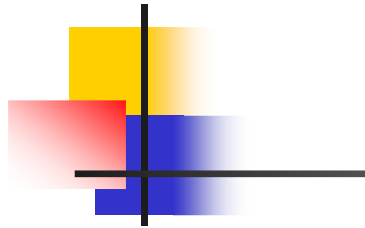

© 2003 Brooks/Cole Publishing / Thomson Learning

Figure 3.50 Planes in a cubic unit cell for Problem 3.53.

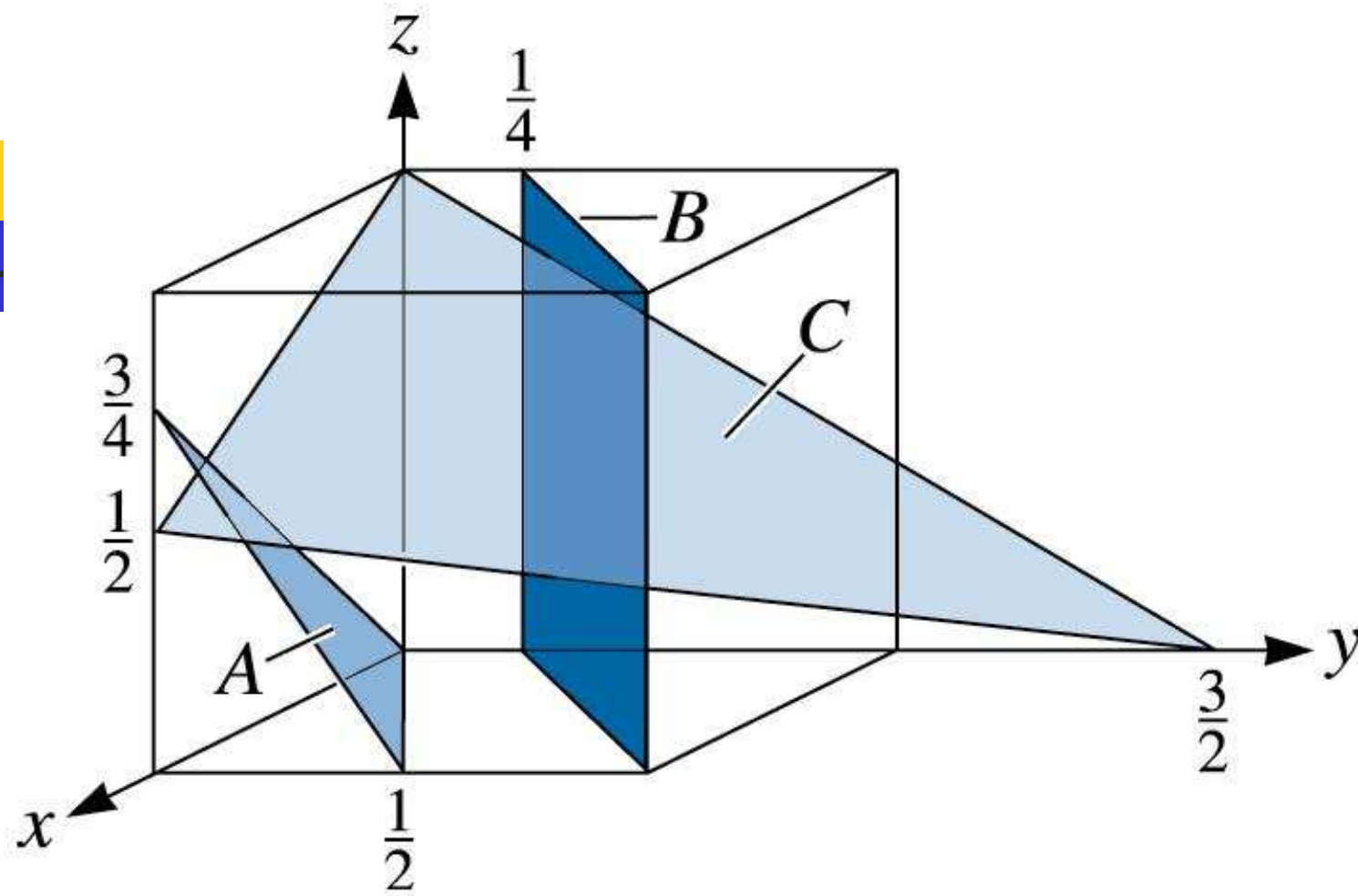
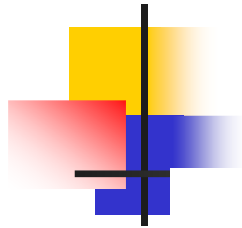
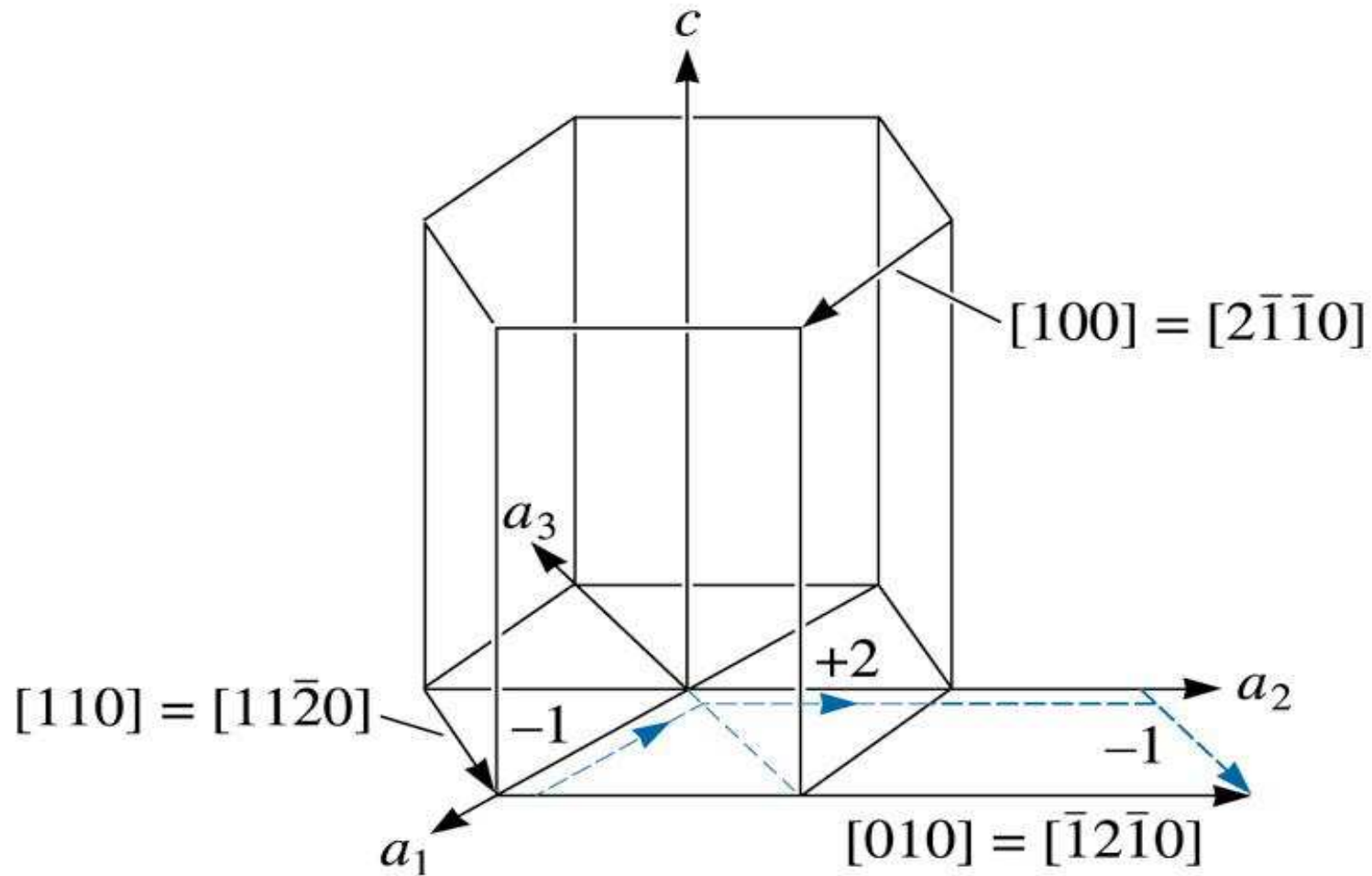

Figure 3.51 Planes in a cubic unit cell for Problem 3.54.



Direções (sist. hexagonal)





Índices no sistema hexagonal

- Por que usar a notação de Miller-Bravais de 4 índices?
 - Para que as direções $[hkil]$ e planos $(hkil)$ equivalentes tenham um conjunto similar de índices.



Conversões de índices

- Miller-Bravais para Miller
 - Direções: $[uvtw]$ para $[u'v'w']$
 - $u'=u-t$, $v'=v-t$ e $w'=w$
 - Planos: $(hkil)$ para $(h'k'l')$
 - $h'=h$, $k'=k$ e $l'=l$
- Miller para Miller-Bravais
 - Direções: $[uvw]$ para $[u'v't'w']$
 - $u'=(2u-v)/3$, $v'=(2v-u)/3$, $t'=-\frac{u+v}{3}=-\frac{u'+v'}{3}$ e $w'=w$
 - Planos: (hkl) para $(h'k'i'l')$
 - $h'=h$, $k'=k$, $i'=-\frac{h+k}{3}$ e $l'=l$

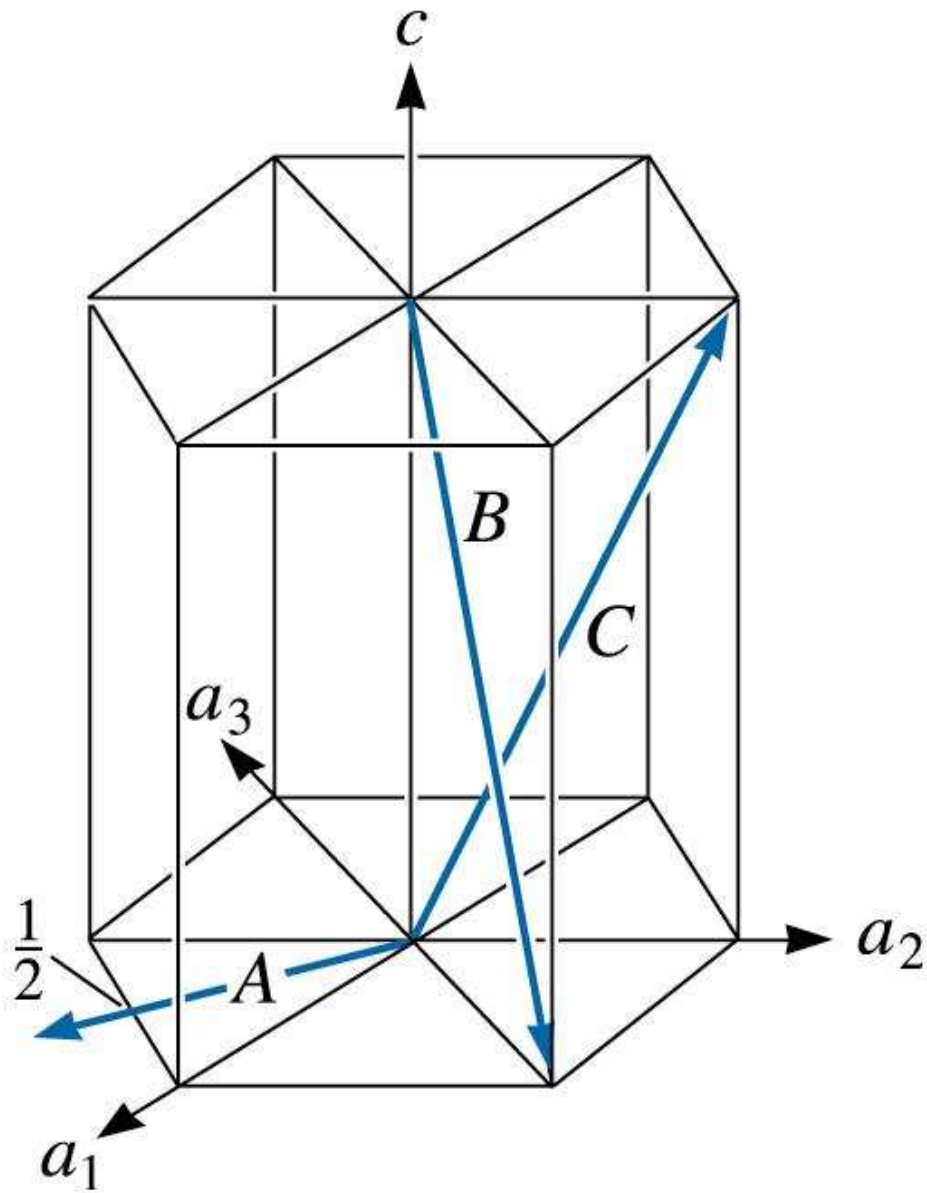

Figure 3.52
Directions in a
hexagonal lattice for
Problem 3.55.

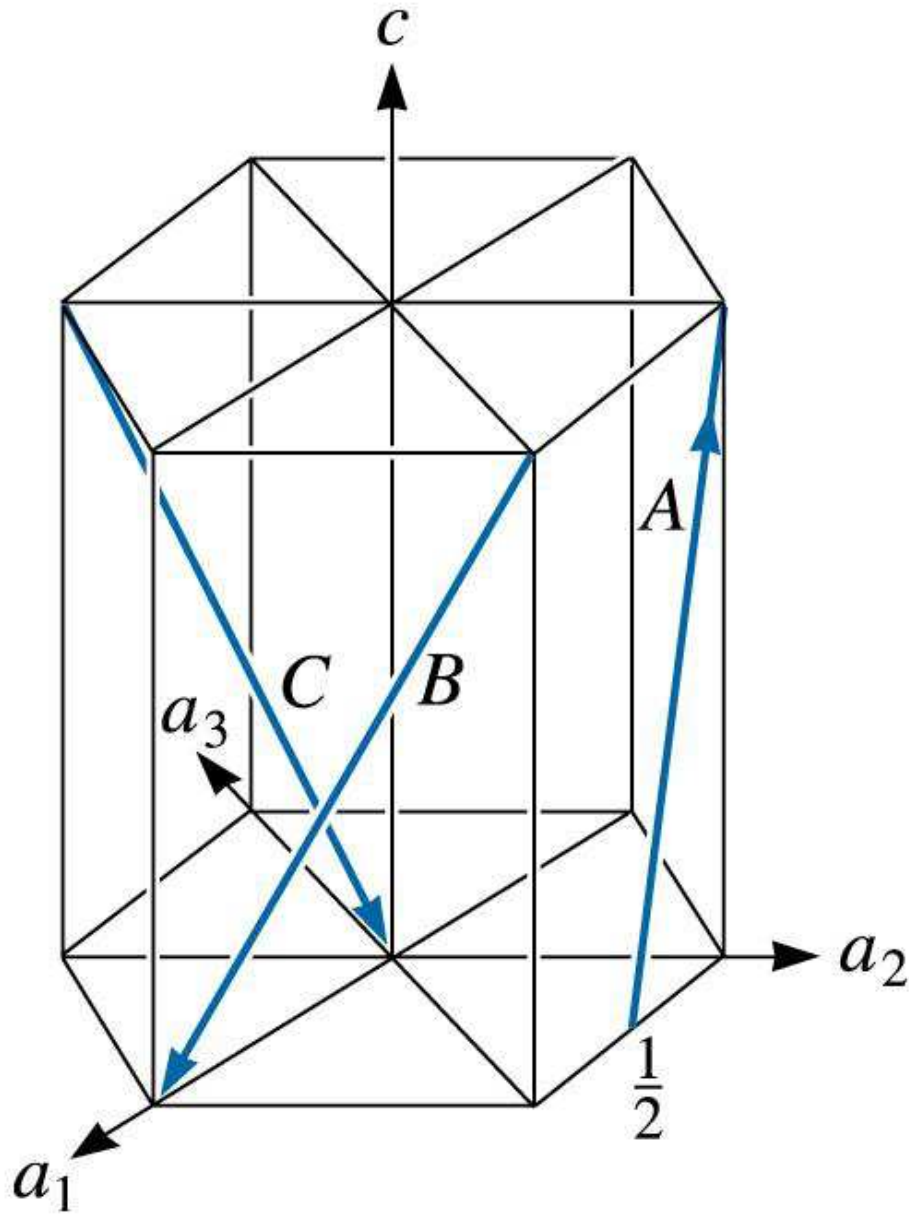
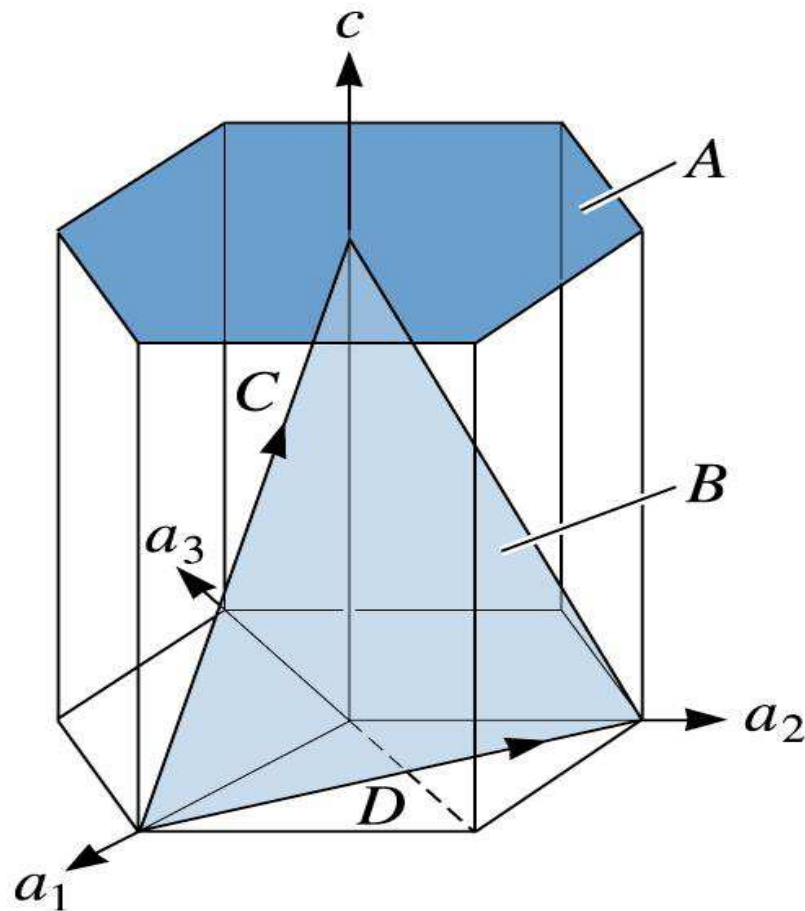

Figure 3.53 Directions in a hexagonal lattice for Problem 3.56.

Planos (sist. Hexagonal)



Exemplos

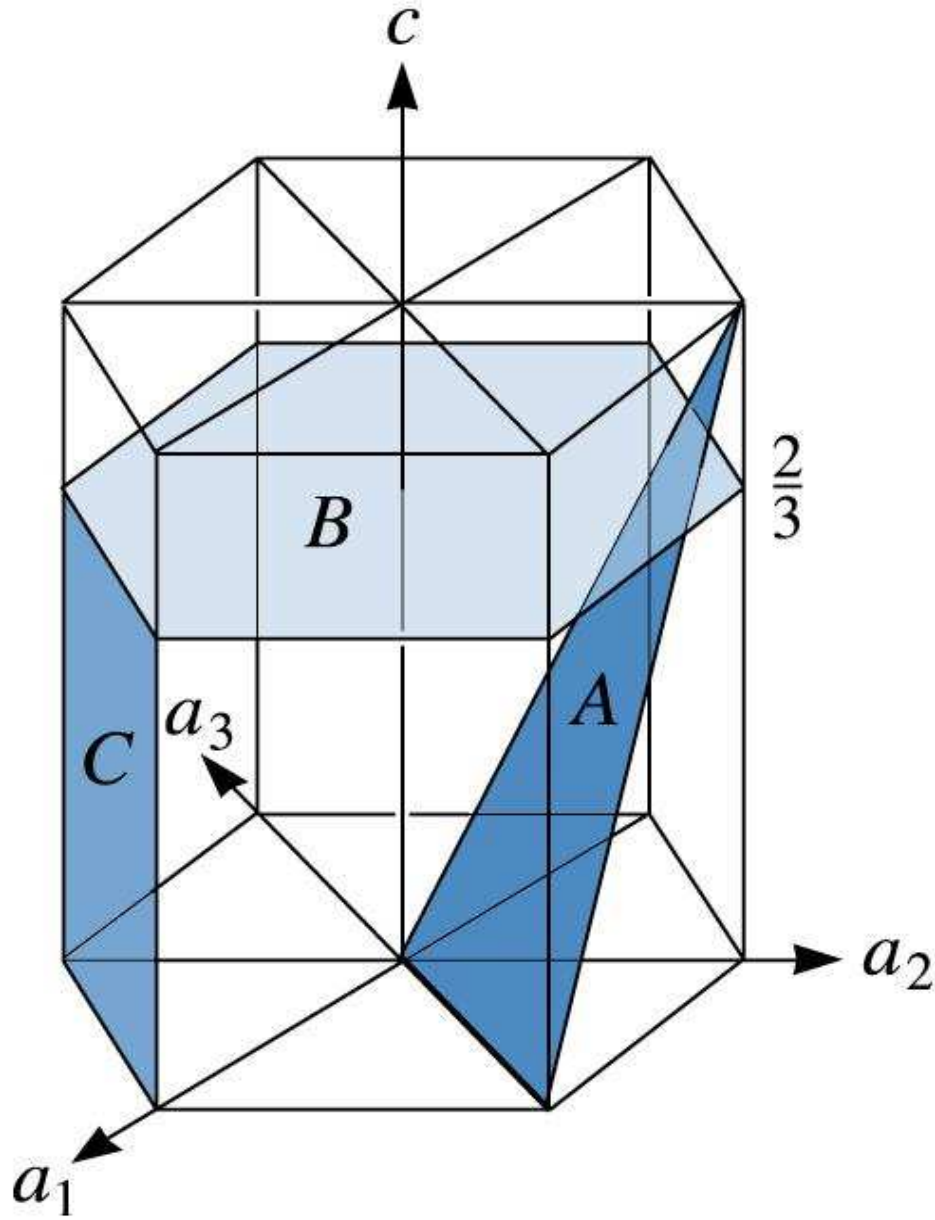

Figure 3.54 Planes in a hexagonal lattice for Problem 3.57.

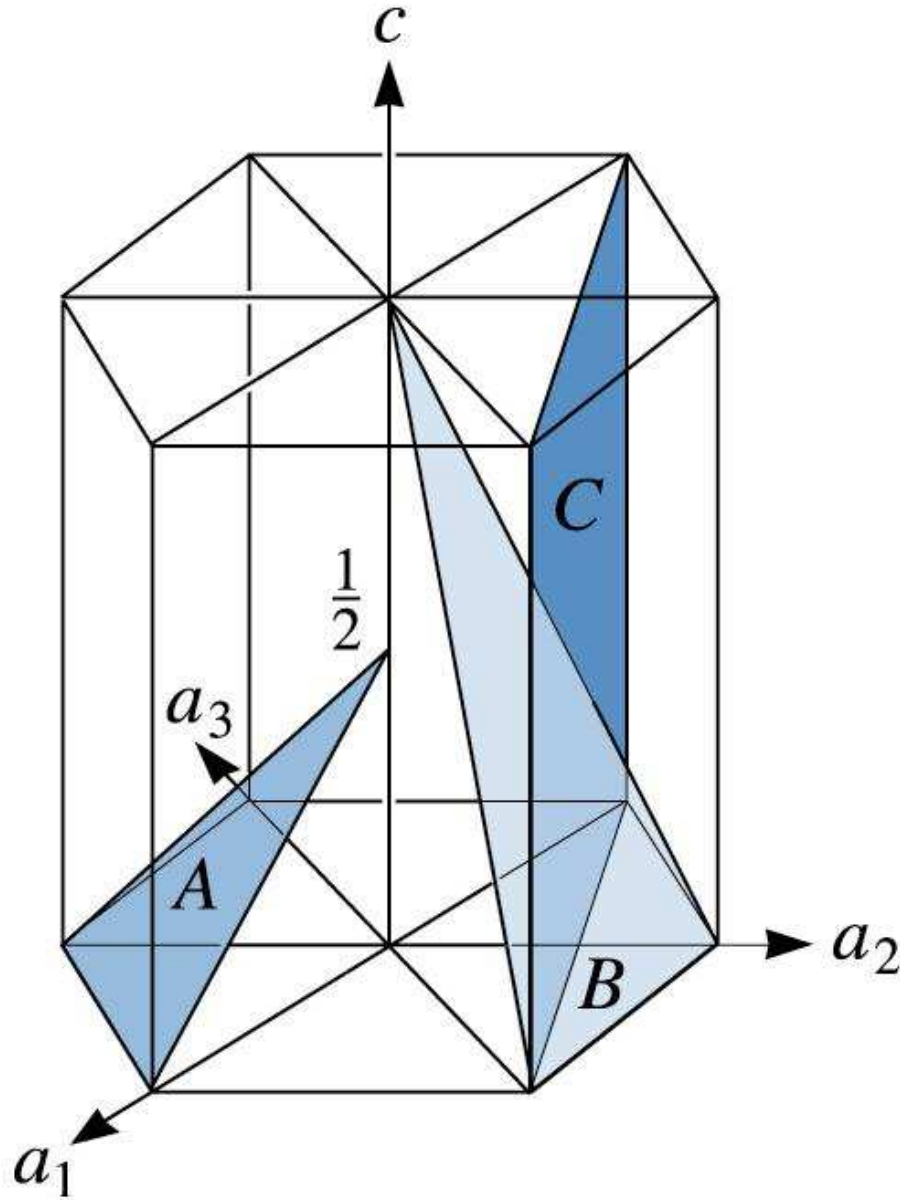
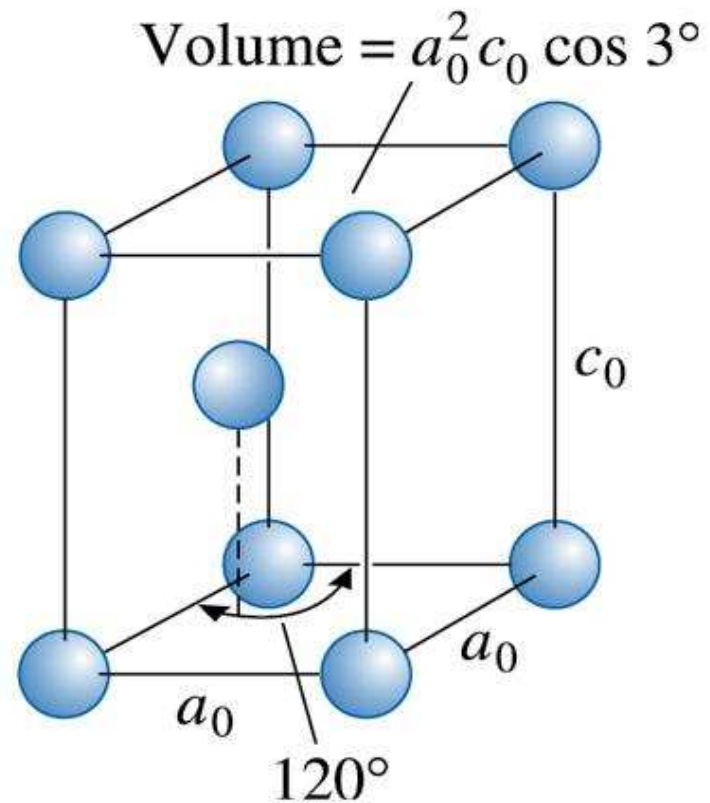
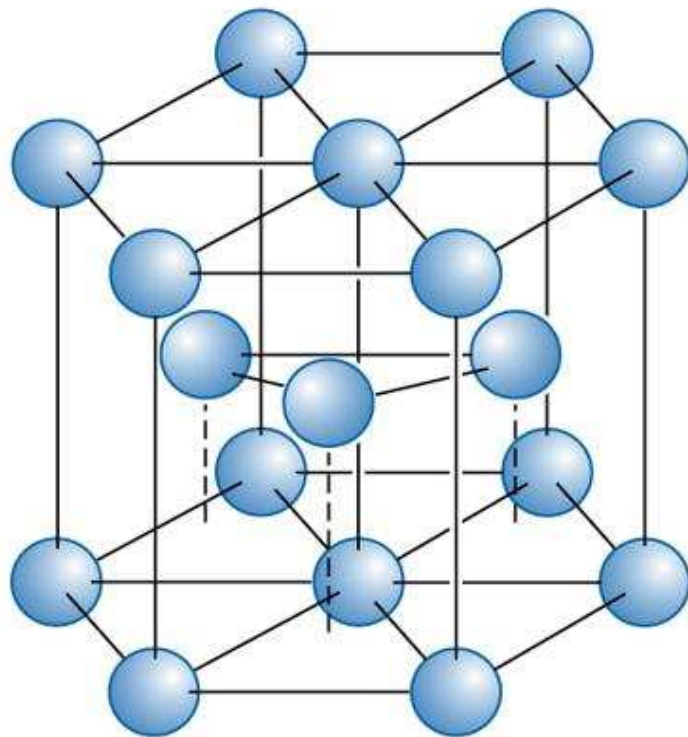

Figure 3.55 Planes in a hexagonal lattice for Problem 3.58.

Estrutura hexagonal compacta (HCP)





HCP (empilhamento de planos)

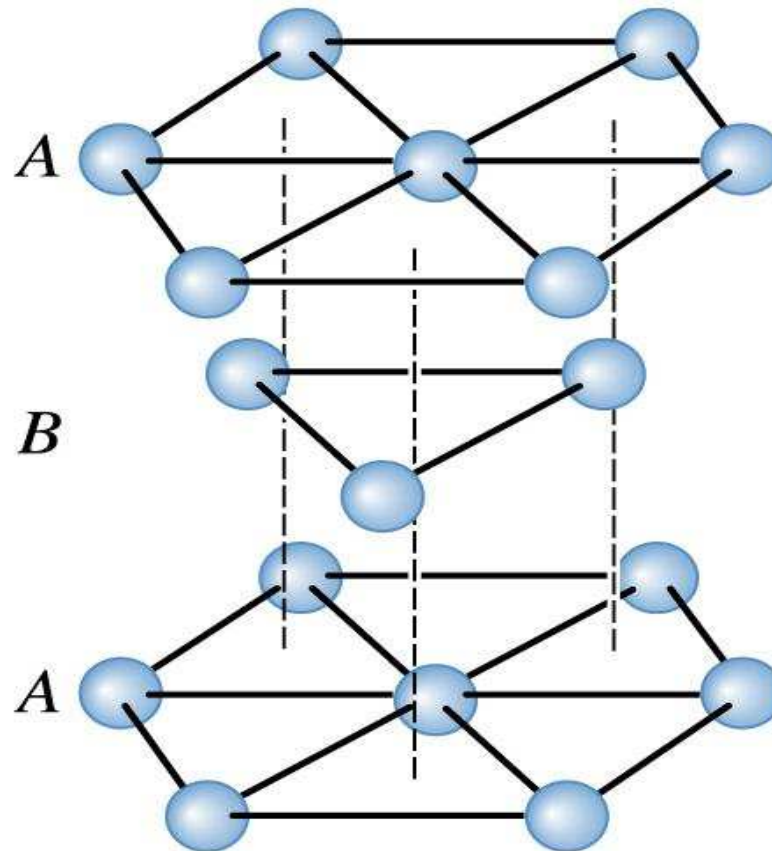

CFC (empilhamento de planos)

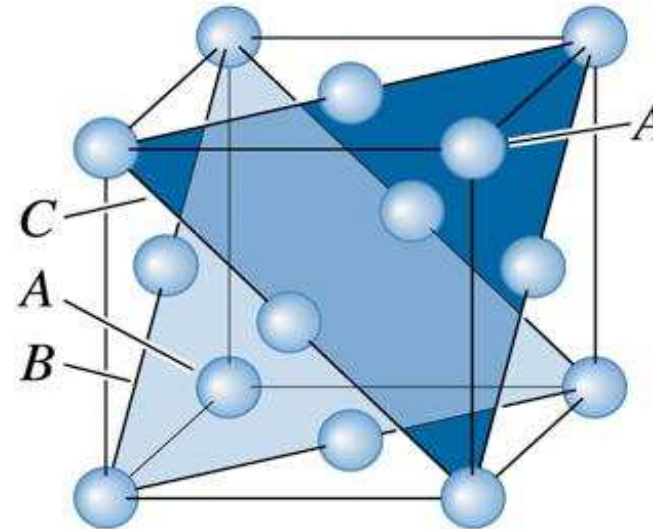
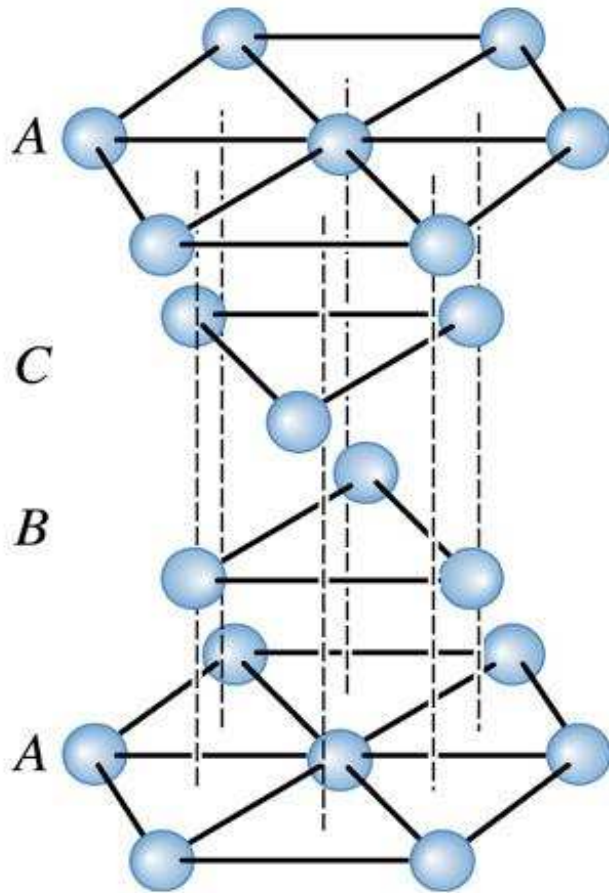

Interstícios

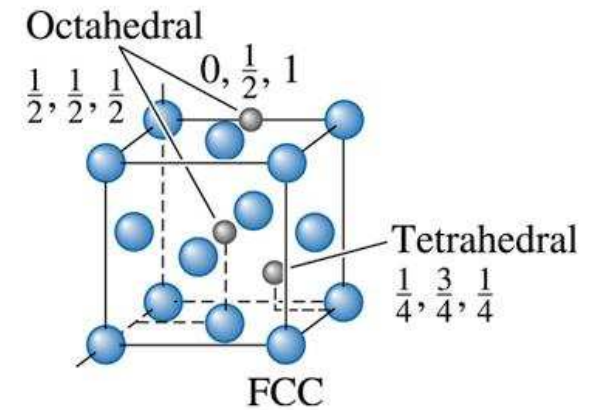
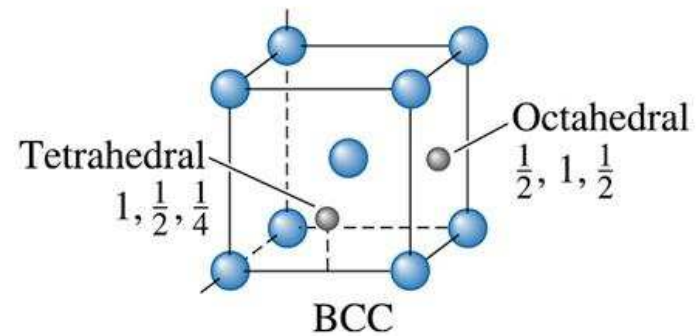
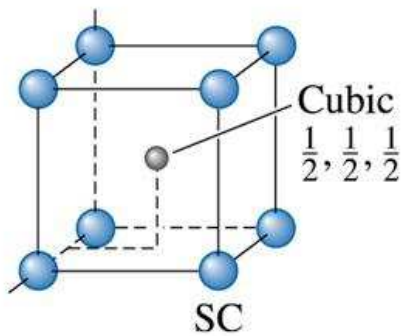

Espalhamento de raios-X pelos átomos

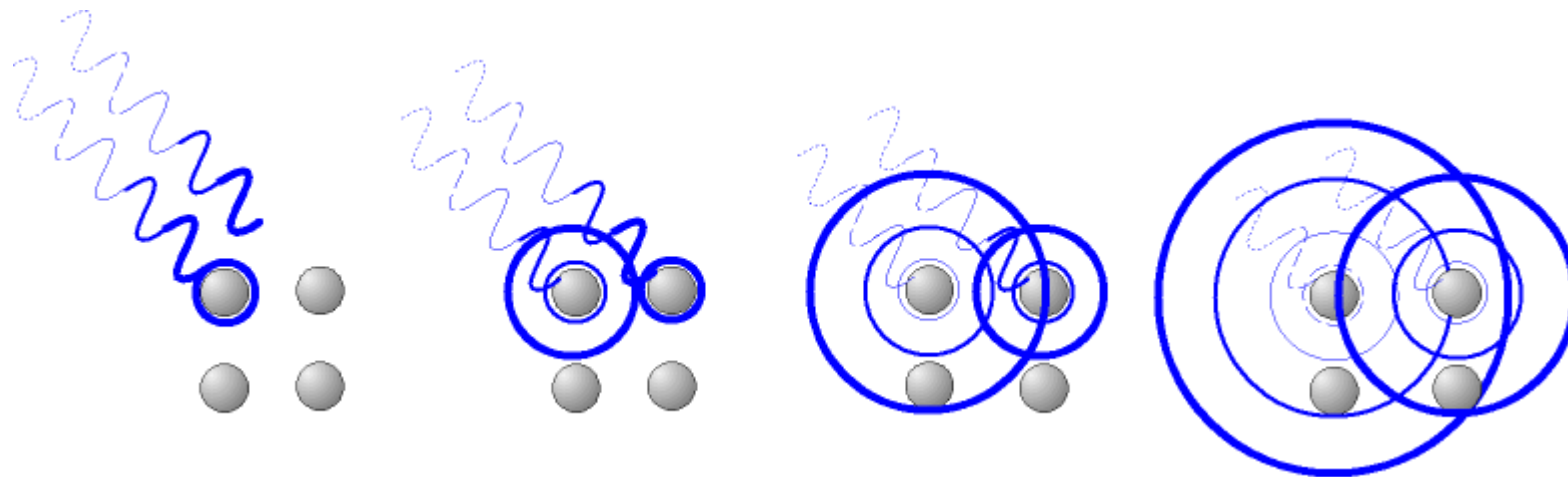

Cada átomo é um centro de espalhamento do raio-X incidente para todas as direções

O fenômeno da Difração

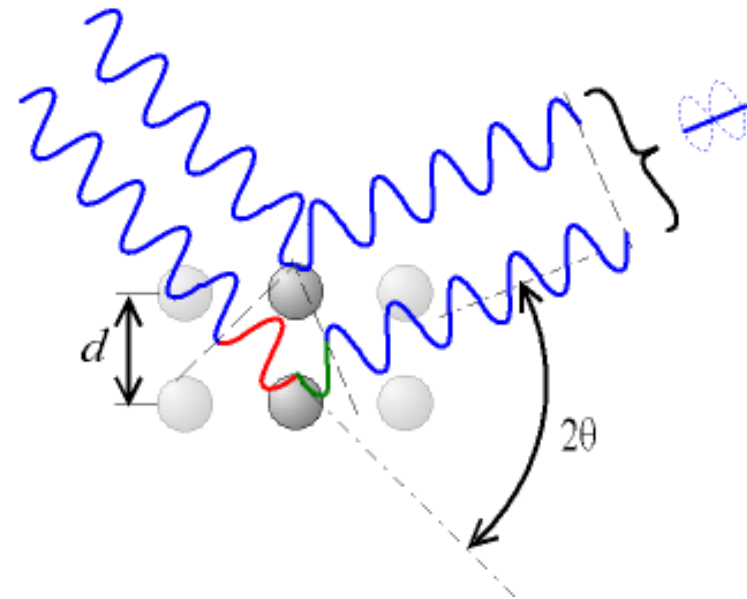
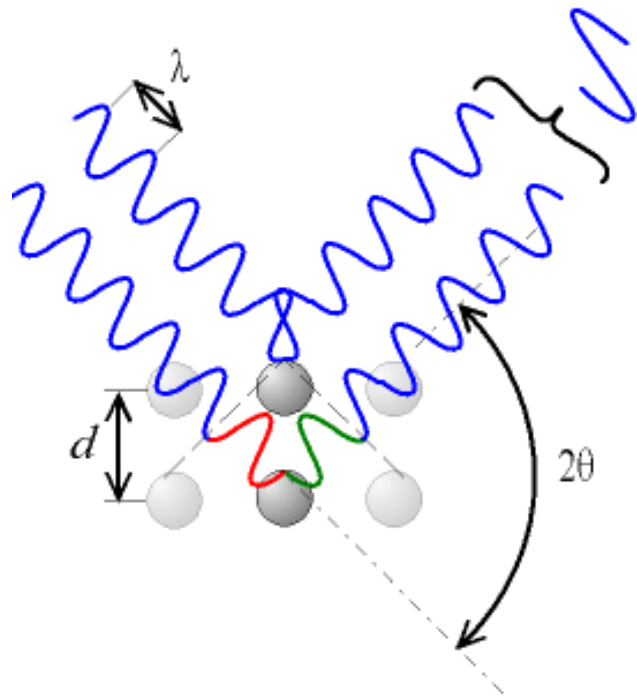

Somente direções específicas produzem interferência construtiva

A Lei de Bragg

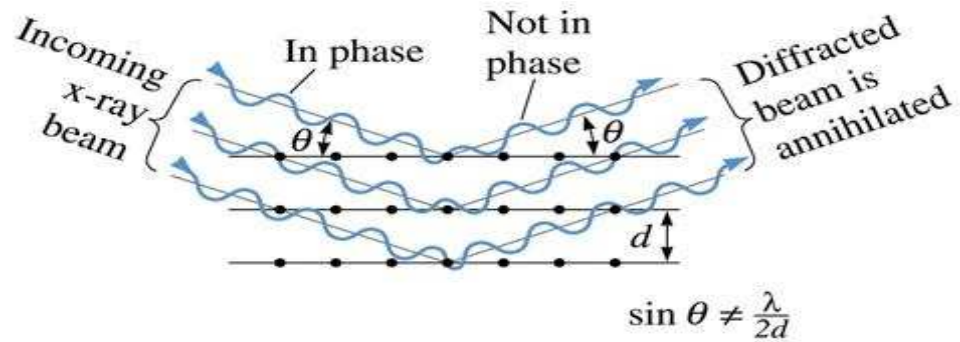

(a)

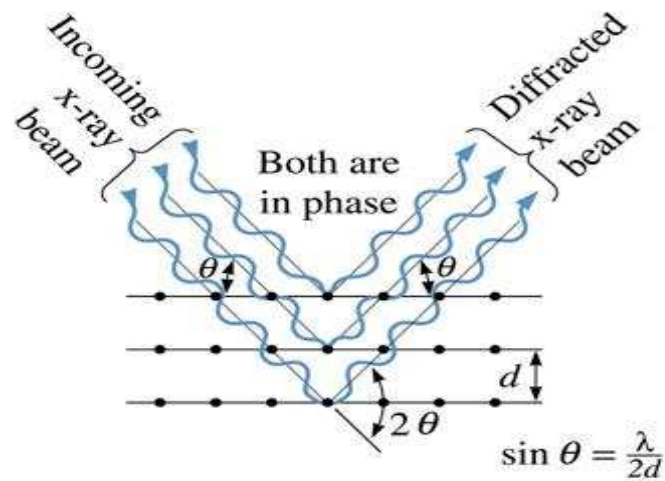

(b)

Lei de Bragg

É necessária mas não suficiente para a difração.



Fator estrutural para a difração

p/ CCC

$$F_{hkl} = \begin{cases} 2f, & h+k+l = \text{par} \\ 0, & h+k+l = \text{ímpar} \end{cases}$$

p/ CFC

$$F_{hkl} = \begin{cases} 4f, & h,k,l \rightarrow \text{ímpares} \\ 4f, & h,k,l \rightarrow \text{pares} \\ 0, & h,k,l \rightarrow \text{mistos} \end{cases}$$

Difratograma

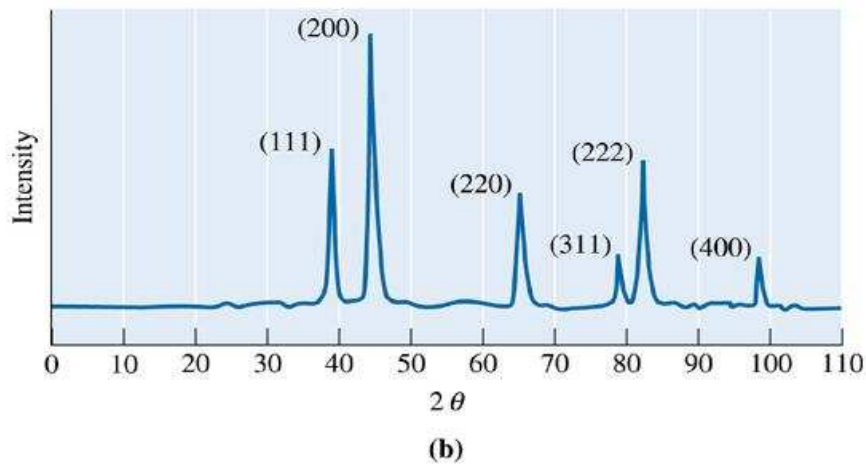
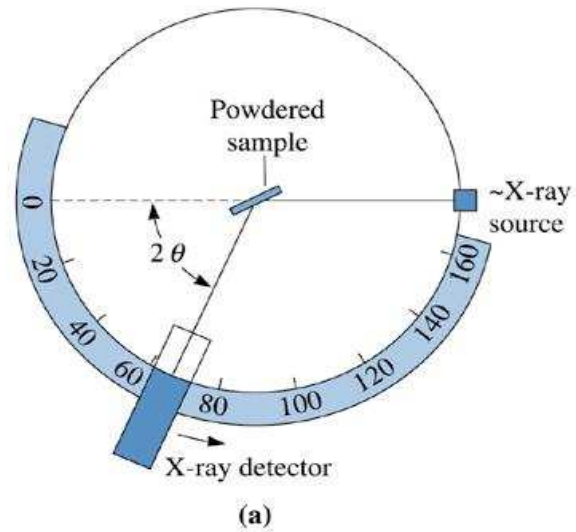



Metais Amorfos

- Exibem somente ordem de curto alcance
- Cristalizam no aquecimento
- Podem apresentar transição vítrea
- Propriedades diferentes com relação aos equivalentes cristalinos, maior RM, menor E, maior dureza, maior resist. à corrosão, etc.