

# Design of High Performance and Low Cost Line Impedance Stabilization Network for University Power Electronics and EMC Laboratories

D. Sakulhirirak\*, V. Tarateeraseth\*\*, W. Khan-ngern\* and N. Yoothanom\*\*\*

\*King Mongkut's Institute of Technology Ladkrabang, Faculty of Engineering, Bangkok, Thailand.

\*\*Srinakharinwirot University, Faculty of Engineering, Ongkharak, Thailand.

\*\*\*Sripatum University, Faculty of Engineering, Bangkok, Thailand.

**Abstract**-- This paper proposes how to analyze and design the Line Impedance Stabilization Network (LISN). The details are described component characteristics and how to design air coil inductors in single and multi layers based on a high self resonant frequency response concept. According to the CISPR 16-1 standard, the stabilized impedance  $50 \Omega$  of LISN at frequency range 150 kHz to 30 MHz is proved by simulation and experimental results. The proposed LISN is successful design the low cost by compare with commercial LISN. Finally, the performance of the proposed LISN is achieved comparing to CISPR standard and also with commercial LISN.

**Index Terms**--LISN, AMN, EMI, EMC

## I. INTRODUCTION

Line Impedance Stabilization Network: LISN or Artificial Mains Network: AMN is an important equipment for measuring the conducted Electromagnetic Interference (EMI) emissions following CISPR 16-1 standard. There are three main functions of LISN or AMN. Firstly to prevent incoming Radio Frequency (RF) disturbance from the mains supply. Secondly, to maintain the specified impedance at the equipment under test (EUT) terminal over the working frequency range and finally to couple RF voltage signal from the EUT to the measuring receiver.

There are two basic types of LISN, the v-network and the delta-network. The LISN v-network can be coupled the unsymmetric voltages: the amplitude of the vector voltage  $V_a$  or  $V_b$  where  $V_a$  is the vector voltage between one of the main terminals and earth and  $V_b$  is vector voltage between the other main terminals and earth. The LISN delta-network can be coupled the symmetric (Differential Mode: DM) and asymmetric (Common Mode: CM) voltages separately [1].

This paper proposes designing of the artificial mains  $50 \Omega / 50 \mu\text{H} + 5 \Omega$  V-network by improved self resonant frequency (SRF) of inductors as in [2] using air gap winding technique. To improve the previous researched work [2], the line/neutral selector switch as shown in Fig. 1 is removed because of two reasons: firstly, two output ports can provide voltage signal from line to ground and neutral to ground simultaneously as shown in equations (1-2), and lastly, this proposed LISN is designed

to apply with other conducted EMI emissions investigated devices such as DM/CM rejection network [3] or Paul-Hardin noise separation network [4] for more advanced research opportunities.

$$V_{\text{Line-Ground}} = 50 \cdot (I_{\text{CM}} + I_{\text{DM}}) \quad (1)$$

$$V_{\text{Neutral-Ground}} = 50 \cdot (I_{\text{CM}} - I_{\text{DM}}) \quad (2)$$

where  $I_{\text{CM}}$  is a common mode current

$I_{\text{DM}}$  is a differential mode current

Fig. 1 shows a suitable circuit with the component values according to CISPR 16-1. These are the recommendable schematic and component values. It may be constructed for use with the current up to 100 A. Moreover, the recommended case dimension following the CISPR is 360x300x180 mm. [1]

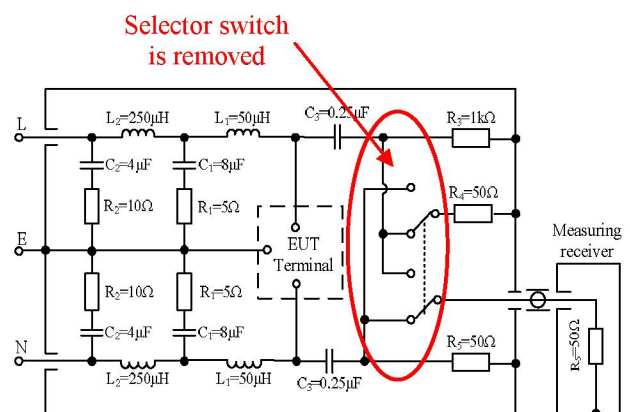

Fig. 1 Artificial mains  $50 \Omega / 50 \mu\text{H} + 5 \Omega$  V-network.

## II. THE PROPOSED SCHEMATIC AND COMPONENT VALUES

Fig. 2 shows proposed schematic of LISN by cut the selector switch off and adding some components such as  $R_7$ - $R_{10}$ ,  $C_7$ - $C_8$  and two BNC type N terminals (female). Table I shows the proposed LISN component values.

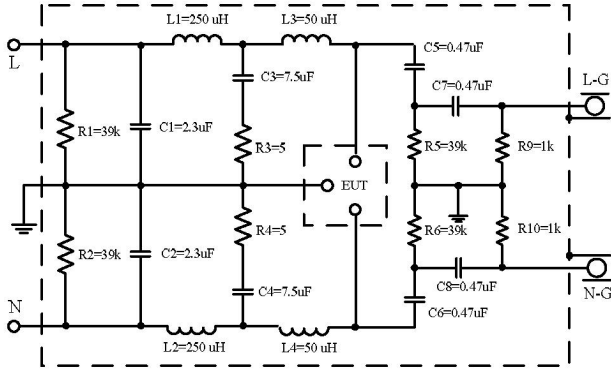

Fig. 2. The proposed schematic of LISN.

TABLE I

PROPOSED LISN COMPONENT VALUES

Component	Value
R <sub>1</sub> , R <sub>2</sub>	39 kΩ (1 W)
R <sub>3</sub> , R <sub>4</sub>	5 Ω (5 W)
R <sub>5</sub> , R <sub>6</sub>	39 kΩ (1 W)
R <sub>7</sub> , R <sub>8</sub>	1,000 Ω (1/2 W)
C <sub>1</sub> , C <sub>2</sub>	2.3 μF
C <sub>3</sub> , C <sub>4</sub>	7.5 μF
C <sub>5</sub> , C <sub>6</sub> , C <sub>7</sub> , C <sub>8</sub>	0.47 μF
L <sub>1</sub> , L <sub>2</sub>	250 μH
L <sub>3</sub> , L <sub>4</sub>	50 μH

L<sub>3</sub>-L<sub>4</sub>, C<sub>3</sub>-C<sub>4</sub>, R<sub>3</sub> and R<sub>5</sub>-R<sub>8</sub> define the impedance; L<sub>1</sub>-L<sub>2</sub>, C<sub>1</sub>-C<sub>2</sub> and R<sub>1</sub>-R<sub>2</sub> provide the isolation to spurious mains signals and mains impedance variations, and C<sub>6</sub>-C<sub>6</sub> decouples the measuring receiver from mains voltage.

### III. THE COMPONENT DETAILS

#### A. Resistors

All resistors are the carbon type and the tolerance should as small as possible. In fact, the resistor, which made from carbon has small response with high frequency.

#### B. Capacitors

The capacitors, C<sub>1</sub>-C<sub>4</sub>, have high capacitance. They should have high rated voltage for the safety reason. Capacitors C<sub>1</sub>-C<sub>4</sub> are the metallized polypropylene. Capacitors C<sub>5</sub>-C<sub>8</sub> are metallized polyester. The SRF of capacitors are provided from manufacturer. The measured self resonant frequency (SRF) response, using impedance analyzer of C<sub>1</sub>-C<sub>2</sub> are about 268 kHz, C<sub>3</sub>-C<sub>4</sub> are about 169 kHz and C<sub>5</sub>-C<sub>8</sub> are about 1 MHz, respectively.

#### C. Case of network

The case of network is mounted on a metal frame, which is then closed by metal lids. The bottom and side

lids are perforated in order to improve the heat dissipation. The dimension of the case is about 300x280x170 mm. This case is smaller than the example case recommended by CISPR 16-1.

#### D. Inductor core and dimension

This is the key point to keep the proposed LISN to cheapest cost. Normally, the solenoidal winding of the inductor is wound on a coil former of an insulating material. Because of the product cost and temperature operation, in this paper, the unplasticized polyvinyl chloride (PVC) pipe is chosen to be as a coil former as shown in Fig. 3 [5].

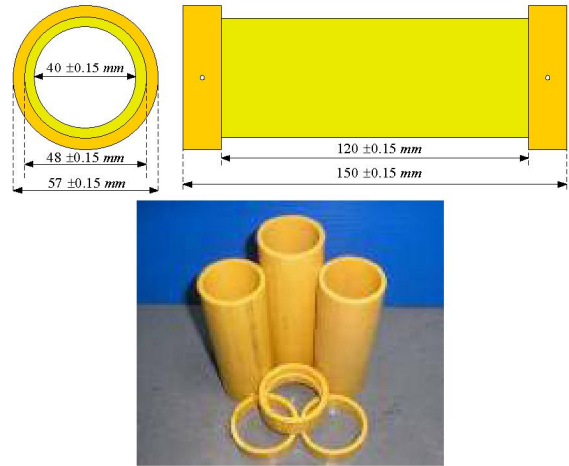

Fig. 3. The coil former of inductors.

### IV. AIR CORE INDUCTOR DESIGN

#### A. Calculations

The inductors, used in proposed LISN, are an air core with solenoidal winding. The unplasticized polyvinyl chloride (PVC) pipe is chosen to be a coil former. The length, diameter and thickness are 120 mm,  $48 \pm 0.15$  mm, and  $1.5 \pm 0.15$  mm, respectively. The maximum operating temperature of PVC pipe is 60 °C [5]. The number of turn and wire size can evaluate by the equations as shown below [2]:

$$a_{wire} = \frac{I}{J} \quad (3)$$

where  $a_{wire}$  is a wire area (mm<sup>2</sup>)  
 $I$  is a rated current (A)  
 $J$  is a current density (A/mm<sup>2</sup>)

The wire size can be evaluated following equation (3). The rated current and current density are defined to be equal to 10 A and 3 A/mm<sup>2</sup>, respectively. The wire diameter is 3.333 mm<sup>2</sup> and AWG 14 is chosen.

$$N = \sqrt{\frac{Ll_m}{A_c \mu_0}} \quad (4)$$

where  $N$  is a total numbers of turn (turns)  
 $L$  is an inductance (H)  
 $l_m$  is a mean magnetic length (m)  
 $A_c$  is a cross section of the core (m<sup>2</sup>)  
 $\mu_0$  is a permeability of air (H/m)

Equation (4) is used specially for calculating the number of turn of  $L_3$  and  $L_4$ . The calculated result is about 52 turns by define  $l_m$  equal to 120 mm.

$L_1$  and  $L_2$  design in multi layer coil using the Wheeler's formula in equations (5-6) [6].

$$L(\mu H) = \frac{0.0315 \cdot N^2 \cdot \left(\frac{r_1 + r_2}{2}\right)^2}{6 \cdot \left(\frac{r_1 + r_2}{2}\right) + 9l_m + 10(r_2 - r_1)} \quad (5)$$

where  $r_1$  is a core inner radius (mm)  
 $r_2$  is an outer radius include the width of wire (mm)

$$N = (N_1 \cdot N_2) - (N_2 / 2) \quad (6)$$

where  $N_1$  is the number of turns per layer (turns)  
 $N_2$  is the number of layers (layers)

Equation (5) is used for designing the number of turn for  $L_1$  and  $L_2$ . The three layers were chosen. The result from equations (5-6) can be found that the number of turns per layer of  $L_1$  and  $L_2$  is about 39 turns per layer.

### B. Winding Techniques

$L_1$  and  $L_2$  are designed in multilayer. To limit interwinding capacitance effect, air gap is added for reducing the turn-to-core and stray capacitance. The turn-to-core capacitance ( $C_{tc}$ ) is equal to two times of total capacitance ( $2C_u$ ). The stray capacitance ( $C_s$ ) is equal to  $C_u/n-1$  [7]. Figs. 4-5 show winding technique applied for  $L_1$  and  $L_2$ . The SRF measurement result is about 960 kHz as shown in Fig. 6.

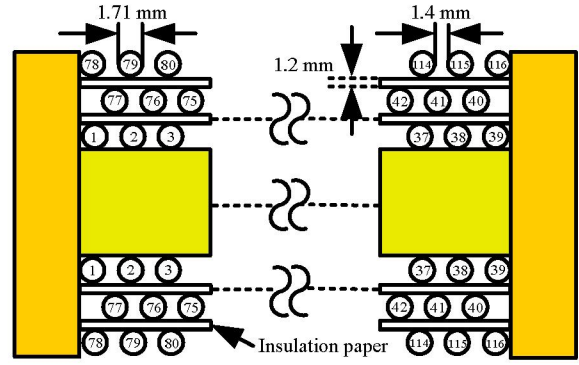

Fig. 4. Model multilayer winding technique of  $L_1$  and  $L_2$ .



Fig. 5. Multilayer winding with air gap of  $L_1$  and  $L_2$ .

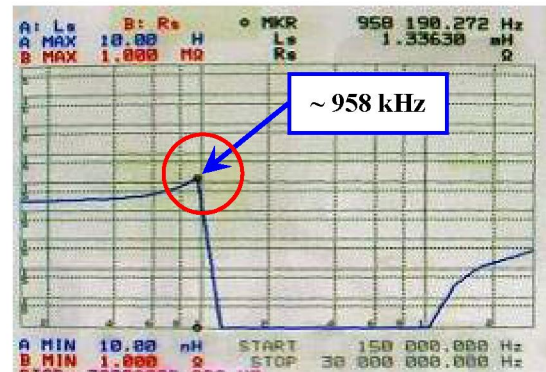

Fig. 6. Measured impedance characteristics of  $L_1$  and  $L_2$ .

$L_3$  and  $L_4$  are single layer with 0.61 mm gap as shown in Fig. 7-8 and the SRF measurement result is about 23 MHz as shown in Fig. 9.

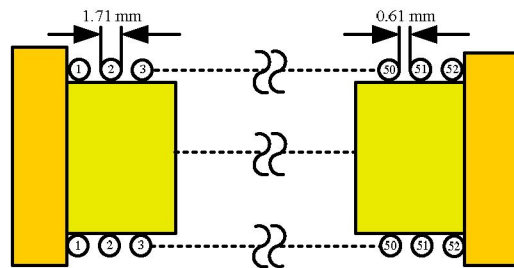

Fig. 7. Model winding technique of  $L_3$  and  $L_4$ .



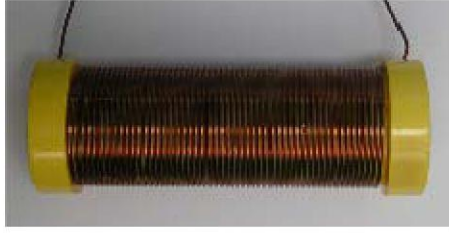

Fig. 8. Single layer winding with air gap of  $L_3$  and  $L_4$ .

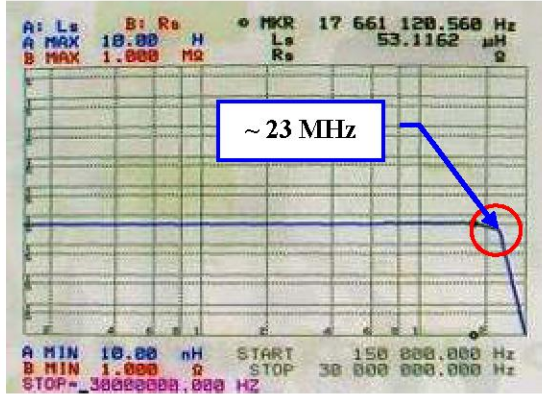

Fig. 9. Measured impedance characteristics of  $L_3$  and  $L_4$ .

Actually, the SRF of  $L_3$  and  $L_4$  are good performance about 17 MHz even though they are not added the air gap. Then the improvement of the SRF also keep the size of core, the small air gap about 0.6 mm is added. But the air gap of  $L_1$  and  $L_2$ , bigger than  $L_3$  and  $L_4$  is chosen to upgrade SRF from about 570 kHz to 960 kHz. Because of the previous research [2], it has some output impedance testing problems at high frequency which could not comply with the CISPR 16-1 requirement.

## V. IMPEDANCE SIMULATION OF PROPOSED LISN

The simulated circuit of proposed LISN, neglected the effect of parasitic elements, is shown in Fig. 10. The AC sweep function of PSpice program is used to simulate the impedance at EUT port.

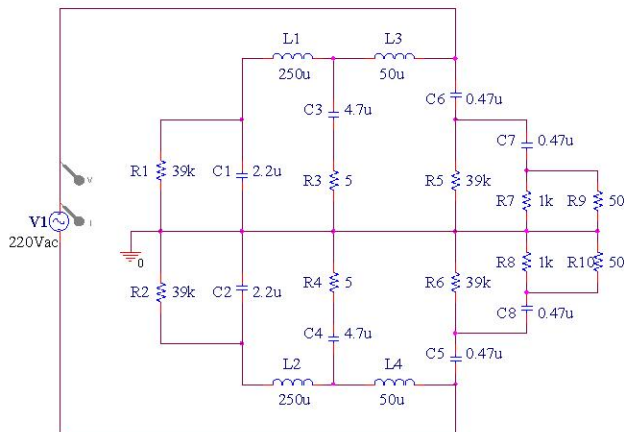

Fig. 10. Simulated circuit by PSpice program.

The simulated result is shown in Fig. 11. The curve increases rapidly in frequency range 30 kHz to 300 kHz and after that the curve provides the stabilized impedance about  $47 \Omega$  until 30 MHz. The simulated result of proposed LISN shows stabilized impedance following standard in frequency range of 150 kHz to 30 MHz.

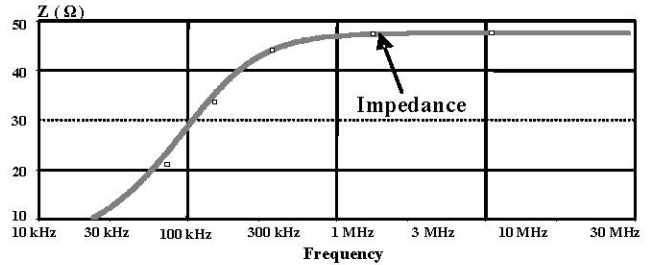

Fig. 11. The impedance at EUT connector.

## VI. EXPERIMENTAL RESULTS

According to CISPR 16-1, the requirements for LISN or AMN testing are the output impedance and the insertion loss. But, due to limitation of equipment in laboratory, the insertion loss can not test. With these reasons, the experiment has divided to three subtopics. The first experiment is to confirm the CISPR 16-1 requirement by measured impedance at EUT terminals of proposed LISN. The second is measured the conducted EMI by using the proposed LISN comparing with commercial LISN. Finally, the temperature of air gap inductor is verified.

### A. Impedance testing method

The impedance measurement, based on CISPR 16-1 methodology, is tested as shown in Fig. 12 [1]. Broadband load  $50 \Omega$  has to connect to BNC RF connector, normally connected to EMI receiver of proposed LISN. The impedance of proposed LISN is measured at EUT terminals between line to ground and neutral to ground respectively.

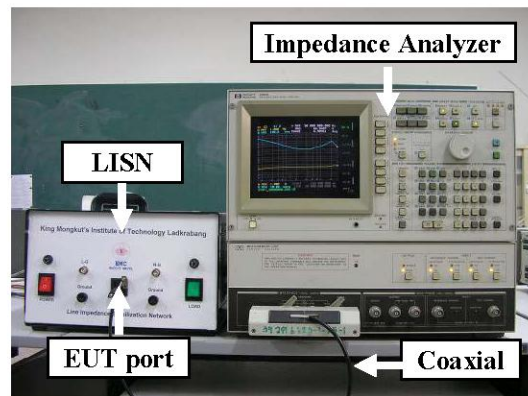

Fig. 12. Impedance testing setup.

The measured impedance from impedance/gain-phase analyzer, as shown in Figs. 13-14, guarantees that the proposed LISN can be provided the impedance about  $50 \Omega$  within  $\pm 20\%$  tolerance at frequency range  $150 \text{ kHz}$ – $30 \text{ MHz}$  for both line to ground and neutral to ground.

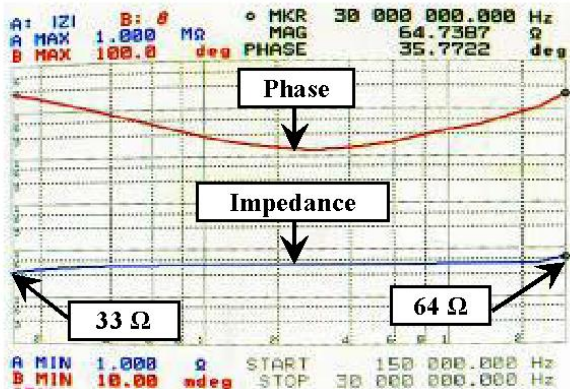

Fig. 13. The measured impedance of proposed LISN at EUT port Line to Ground side.

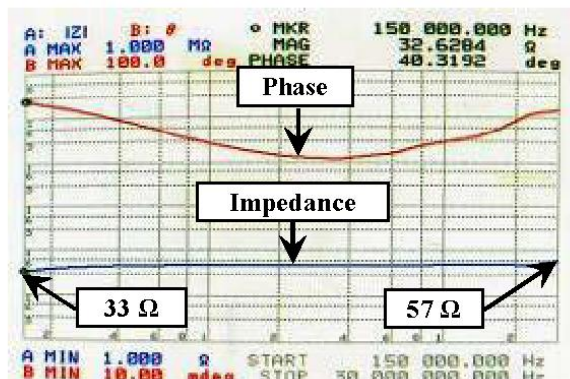

Fig. 14. The measured impedance of proposed LISN at EUT port Neutral to Ground side.

### B. Conducted EMI testing method

In fact, LISN is a device used to transfer energy to load and to detect the conducted EMI to EMI receiver. From these reasons, the proposed LISN has to measure conducted EMI by comparing between the proposed LISN and the commercial LISN. The conditions are the frequency range  $150 \text{ kHz}$ – $30 \text{ MHz}$  following CISPR 22 standard and switching power supply is used as an EUT. Figs. 15-16 show line to ground and neutral to ground noise floor when measured before connecting the EUT. The conducted EMI measured by proposed LISN (blue line) is nearly close to commercial LISN (red line) as shown in Figs. 15-18.

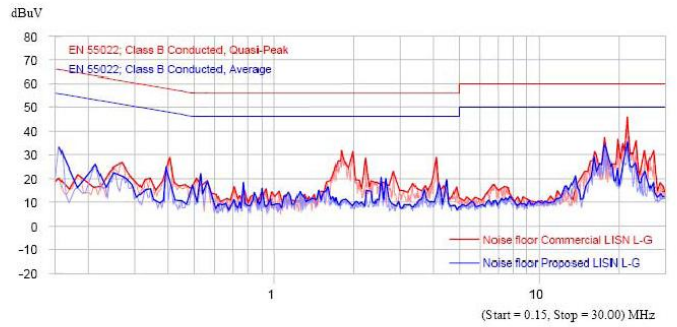

Fig. 15. The measured Line to Ground noise floor.

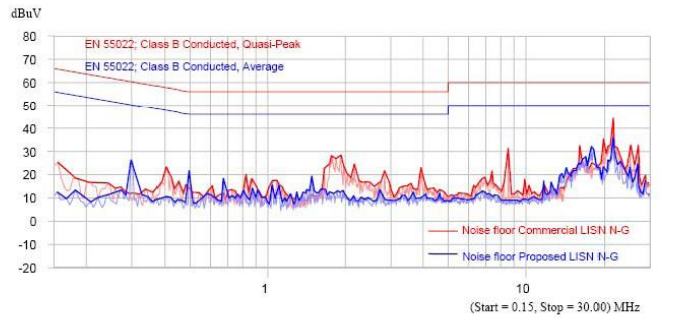

Fig. 16. The measured Neutral to Ground noise floor.

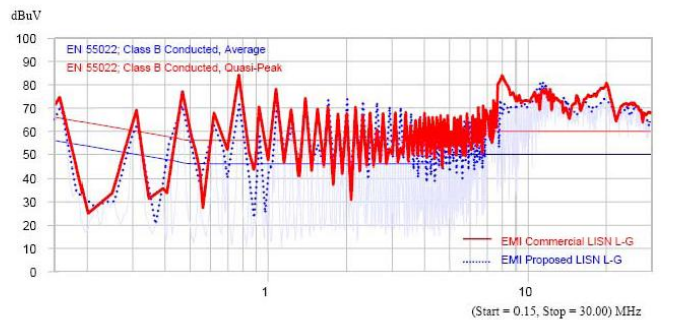

Fig. 17. The measured Line to Ground conducted EMI.

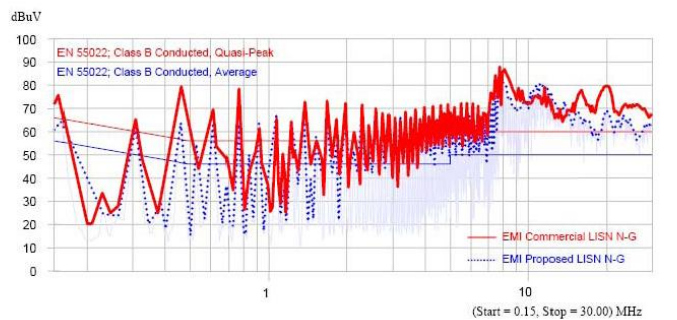

Fig. 18. The measured Neutral to Ground conducted EMI.



### C. Operating temperature testing method

The operating temperature is measured at the middle of core winding of proposed LISN by using infrared thermometer. The testing time period is 60 minutes. The testing conditions are measured in every 5 minutes pass and connecting the continuous 8 A load (incandescent lamp) at EUT connector. From the experimental results as shown in Fig. 19, it can be seen that the operating temperature of proposed LISN is about 10 °C less than maximum temperature limit of PVC cores of proposed LISN.

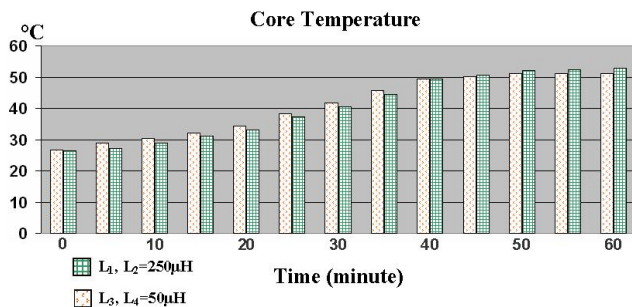

Fig. 19. Temperature measurement

### VII. CONCLUSION

From all of the experimental results, it can be concluded that the proposed LISN can be provided the defined impedance  $50 \Omega \pm 20\%$  and RF coupling signal as the functions of commercial LISN with a cheaper cost due to remove the selector switch and change type of inductor core material from bekalite to PVC. The total cost of the proposed LISN is about 100 US dollars. Finally, the proposed LISN has tested with continuous 8 A load at EUT connector for 60 minutes. The measured temperature at all devices is less than the temperature limit of devices.

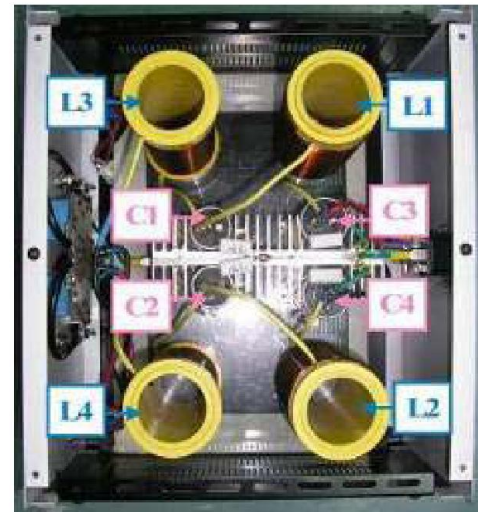

Fig. 20. Top view of the proposed LISN.

### REFERENCES

- [1] C.I.S.P.R. Specification for Radio Disturbance and Immunity Measuring Apparatus and Methods, International Electrotechnical Commission, Geneva, Switzerland, 1999.
- [2] D. Sakulhirirak et al. "An Affordable Line Impedance Stabilization Network Design for Academic Laboratory Institution," ECTI Conf., May 2006, pp 837-840.
- [3] Marco Chiadò Caponet and Francesco Profumo "Devices for the Separation of the Common and Differential Mode Noise: Design and Realization", Applied Power Electronics Conference and Exposition (APEC) Seventeenth Annual IEEE, vol. 1, pp. 100-105, March 2002.
- [4] Clayton R. Paul and Keith B. Hardin "Diagnosis and Reduction of Conducted Noise Emissions", IEEE Trans. on Electromagnetic Compatibility, vol. 30, no. 4, pp. 553-560, Nov 1988.
- [5] Unplasticized polyvinyl chloride pipes for drinking water services, TIS 17-2532, 1989.
- [6] The Magnetic Gun Club. (2002, June 16). Coil Parameter [Online]. Available: <http://mgc314.home.comcast.net/coilparameters.htm>
- [7] A Massarini, M.K. Kazimierczuk and G. Granddi. "Lumped Parameter Models for Single-and Multiple-Layer Inductors," PESC'96, June 1996, vol. 1, pp. 295-301.