

Miniature solutions for voltage isolation

By **Geoff Jones** (Email: gjones@ti.com)

Marketing Manager

The hot growth in distributed-power architecture has fueled the development of miniature low-power (<2-W) DC/DC converters. As their name implies, these devices minimize the impact of the converter onboard space. They provide point-of-use isolated power conversion for analog circuitry in industrial applications and safety-critical applications such as telecommunications and medical equipment. Additionally, miniature DC/DC converters benefit designers who need galvanically isolated output power or noise reduction in analog circuitry.

In most modern noise-sensitive circuitry, system designers often have a small number of components that require total isolation from their input power supply. It is necessary to isolate the load and noise presented to the local power-supply rails from the main-supply rails of the entire system. Mixed-signal integrated circuit (IC) design, for example, frequently leads to nonfunctional devices because of noise problems. Large amounts of digital noise combined with sensitive analog circuitry often results in interference noise.¹

Miniature DC/DC converters with galvanic isolation offer very low output noise and high accuracy. Galvanic isolation helps to reduce system noise by providing a floating ground on the secondary side of the converter.² The input-to-output isolation can then be used to provide a simple, isolated-output power source; or, it could be used to generate different voltage rails, dual-polarity rails, and/or nonstandard voltages. Also, as a noise reduction technique in analog circuitry, the isolation barrier prevents noise from the digital ground bus from affecting the sensitive analog circuits.

The standard brick-type converter is not well suited for this requirement. In addition to its higher cost, the brick's output power is overkill for applications requiring <2 W. What's more, the installed size of a brick is often prohibitive. Designers require miniaturization to save valuable board real estate. Because they are significantly smaller than even the new sixteenth-brick format (0.29 in² vs. 1.17 in²), miniature DC/DC converters are particularly suited to generating onboard voltages in space-constrained designs.

So why not "roll your own" DC/DC power supply? Discrete component onboard converter designs are a low-cost alternative to bricks and off-the-shelf miniature DC/DC converters. However, fewer designers are developing discrete designs because of their disadvantages. Extra functionality, such as

device protection and module-to-module synchronization, are difficult to implement; reliability is often poor; and achieving a small-sized power supply is difficult. In addition, many designers of higher-level products—of which the DC/DC converters are only one component—lack the time to become expert enough in converter design to build their own devices. As a result of these challenges, more and more designers are specifying miniature DC/DC converters for their applications. The converters offer significantly lower risk, much faster time to market, and development-cost savings.

Besides their advantages over bricks and discrete designs, miniature DC/DC converters also provide a compact-sized power solution for point-of-load (POL) power conversion. POL converters enable designers to overcome the challenges caused by the high peak-current demands and low-noise margins of the latest high-performance semiconductor devices. The converters can be placed close to their loads. This minimizes losses caused by voltage drops, helps overcome noise sensitivity and EMI emission issues, and ensures tight regulation under dynamic load conditions.

What's available?

Miniature DC/DC converters offered by C&D Technologies, Texas Instruments, Wall Industries, and others benefit designers who require isolation and output current in the 20- to 500-mA range. The converters are available with 5-, 12-, 15-, or 24-V inputs. Single-output converters are available with voltages from 3.3 to 24 VDC. Dual-output converters with voltages from ± 3.3 to ± 24 VDC are also available.

Miniature DC/DC converters offer regulated or unregulated outputs with input-to-output isolation ratings of 1000, 1500, or 3000 VDC. Operating temperature extends from -40°C to $+100^{\circ}\text{C}$. Due to their high switching frequencies (up to 400 MHz), the converters deliver efficiencies of up to 85%.

Built-in features

For system designers seeking to implement miniature DC/DC converters, the devices offer various built-in features that ease system integration and simplify design. Many of the available products incorporate thermal and short-circuit protection and internal filtering. Some of the more advanced converters allow device-to-device synchronization. If an application uses more than one converter on a PC board,

Figure 1. Self-synchronizing DC/DC converters in distributed-power application

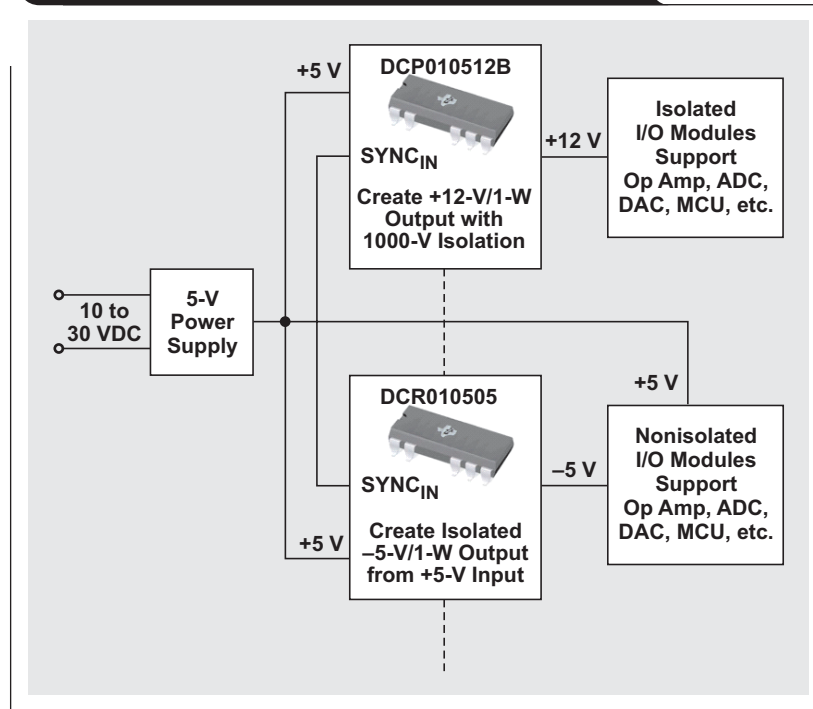

beat frequencies and other electrical interference can be generated. DCP010512B and DCR010505 converters (Figure 1) overcome this problem with a built-in synchronization control that allows multiple converters to be synchronized to one another. The feature makes it easy for designers to synchronize up to eight devices by connecting the SYNC_{IN} pins together. This eliminates electrical interference caused by variations in switching frequencies.

Construction

Today’s DC/DC converter technologies continue to focus on higher densities and efficiencies as well as on smaller packages. One of the more innovative converters is manufactured with the same technology as standard IC packages, including dual-in-line (DIL) and small-outline (SO) styles

(Figure 2). They use an IC lead-frame as the medium to interconnect silicon devices and magnetic components within the IC package (Figure 3). The result is an isolated DC/DC converter that provides high reliability, excellent thermal management, small size, and compatibility with standard board-assembly processes. The standard IC format also allows tape-and-reel assembly, which helps reduce manufacturing costs.

Figure 2. Miniature isolated DC/DC converter in standard IC package

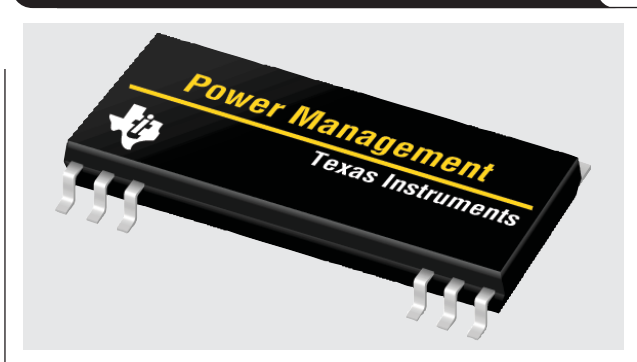
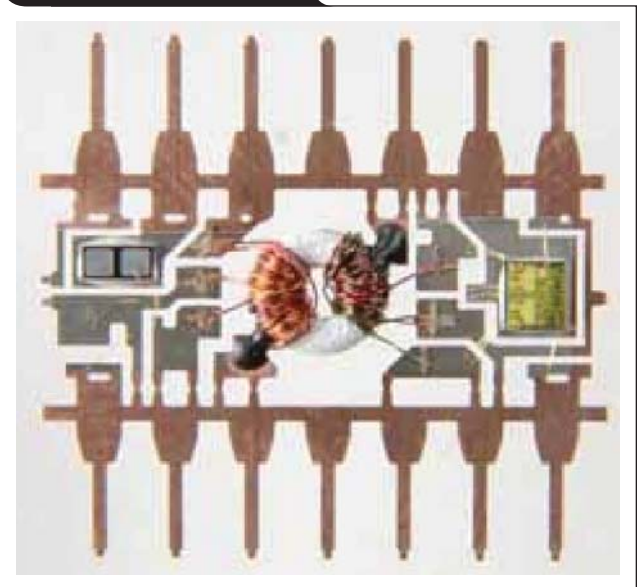

Figure 3. IC lead-frame



Different configurations

The galvanic isolation of the output from a miniature DC/DC converter allows nonstandard voltage rails to be generated by connecting multiple converters in series. This is accomplished by simply connecting the positive output of one converter to the negative output of another. This configuration allows a wide variety of voltage variations to be produced. The outputs on some dual-output converters can also be connected in series to provide two times the magnitude of output voltage. Figure 4 shows a dual $\pm 15\text{-V}$ converter connected to provide a 30-V rail.³

Multiple converters connected in parallel often provide a suitable solution for cases where a single converter is unable to deliver the required output power. When parallel connection is used, it is always a good design practice to use parallel converters of the same type. Figure 5 shows two converters connected in parallel.²

Addressing voltage isolation in low-power applications

Miniature DC/DC converters that provide input-to-output isolation and low output power offer innovative solutions for high-density power-supply designs in a variety of applications. Some typical examples include industrial process control, DC motor drive, test and measurement, power transmission, medical equipment, and data acquisition.

Figure 4. Connecting dual-output converters in series

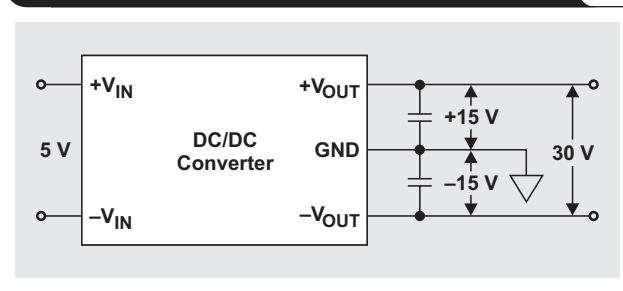

Figures 6-8 show examples of DC/DC converters and operational amplifiers (op amps) used in common power-supply designs.

Positive-to-negative voltage conversion

Positive-to-negative voltage conversion is a popular application for miniature DC/DC converters. Precision op amps are optimized for higher-speed applications. The devices offer very low offset voltage and drift and are commonly found in data acquisition, telecom equipment, professional audio equipment, and portable applications requiring high precision. Some op amps require complementary power-supply

Figure 5. Connecting multiple DC/DC converters in parallel

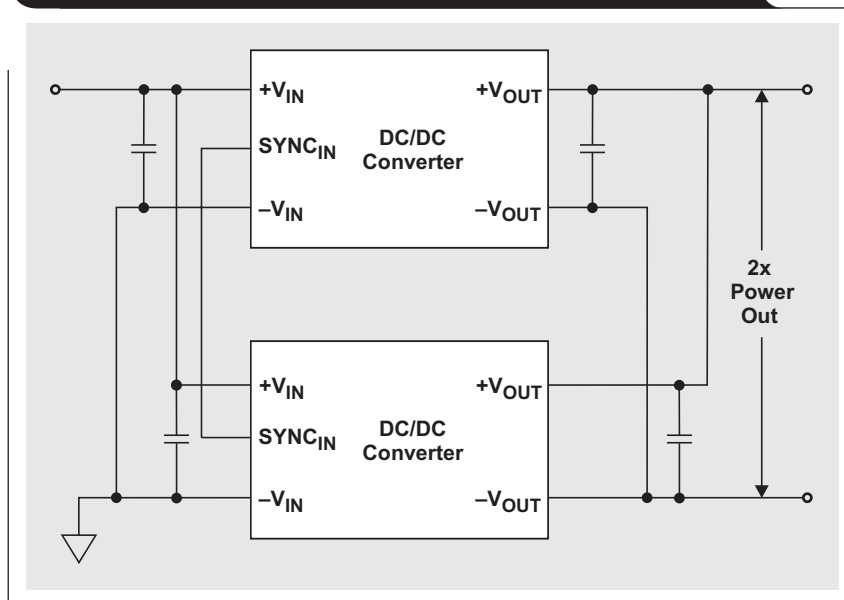

Figure 6. Positive-to-negative voltage from single supply

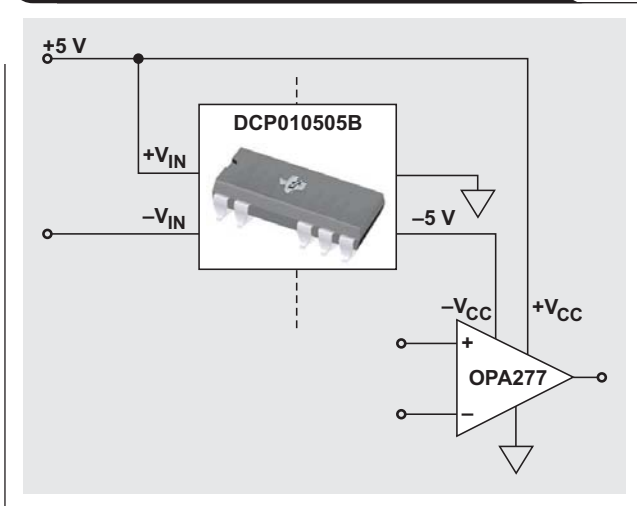
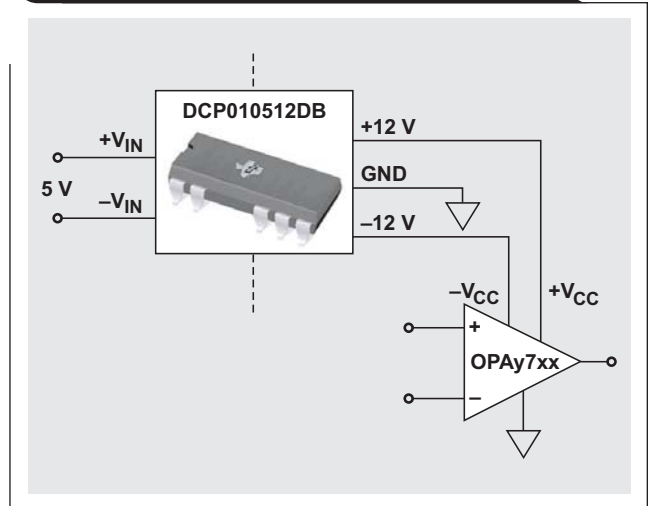

Figure 7. Positive and negative voltage from single supply



rails. The isolated output of the converter in Figure 6 is used to generate a negative supply voltage. The isolated negative output is referenced to the op amp's positive input.

Positive and negative voltage from a single supply

Miniature DC/DC converters in standard IC packaging reduce the board space required to create positive and negative output voltages to an op amp. Figure 7 shows the ability of a single isolated converter to create positive-to-negative output voltages efficiently for a signal conditioning circuit with differential input. The dual-output converter is used to create unregulated output voltages with a magnitude higher than its +5-V input. Operating from an input

voltage range of 4.5 to 5.5 V, the converter performs a boost function that creates a +12-V output and a buck-boost function with a -12-V output.

Power-supply isolation for AC or DC instrumentation amplifier

The challenge for system designers working with signal conditioning circuits in AC or DC instrumentation amplifiers is to eliminate ground loops that can affect measurement accuracy. Miniature isolated DC/DC converters achieve this goal. The circuit in Figure 8 uses a dual-output DC/DC converter to produce an isolated voltage. The converter is used in conjunction with a precision isolation amplifier to

Figure 8. Power-supply isolation for AC or DC instrumentation amplifier

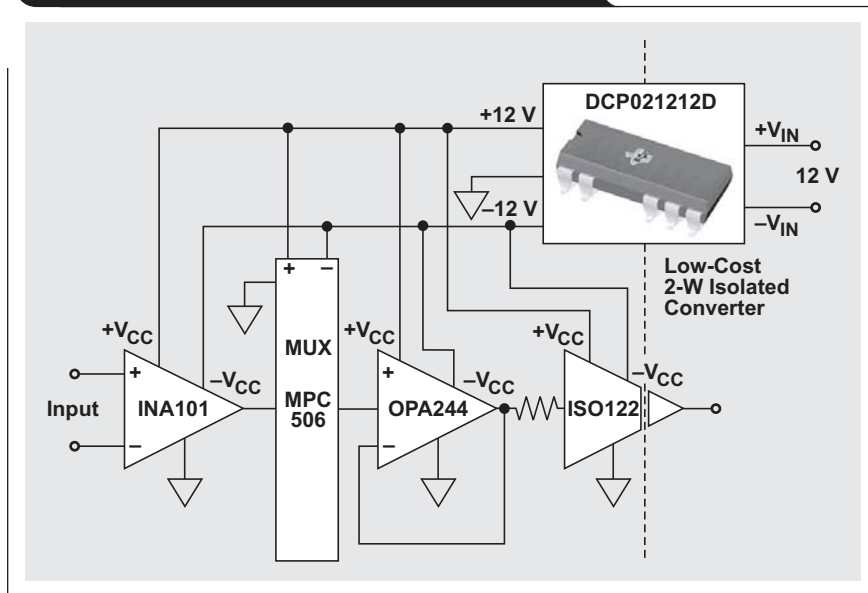

fully isolate the instrumentation from noise generated by other parts of the circuit. The isolation barrier characteristics do not affect the signal integrity, resulting in excellent reliability and good high-frequency immunity across the barrier.

Summary

In most modern noise-sensitive circuitry, system designers often have a small number of components that require total isolation from their input power supply. Miniature DC/DC converters effectively isolate the load and noise presented to the local power-supply rails from the main-supply rails of the entire system.

The off-the-shelf devices use a highly integrated package design that makes them suitable for a wide range of applications in space-constrained board designs. They are smaller and lower-priced than the standard brick-type converters. When compared to discrete designs, miniature DC/DC converters offer lower risk, much faster time to market, and development-cost savings.

References

For more information related to this article, you can download an Acrobat Reader file at www-s.ti.com/sc/techlit/litnumber and replace “*litnumber*” with the **TI Lit. #** for the materials listed below.

Document Title	TI Lit. #
1. “Noise Reduction is Crucial to Mixed-Signal ASIC Design Success,” <i>Electronic Design</i> (October 30, 2000).	—
2. “Packaged DC-DC Converters Solve Distributed Power Dilemmas,” <i>Electronic Design</i> (June 12, 2000).	—
3. “Miniature, 2W Isolated Unregulated DC/DC Converters,” DCP02 Series Datasheetsbvs011	

Related Web sites

power.ti.com

www.ti.com/sc/device/partnumber

Replace *partnumber* with DCP010512B, DCP010512BD, DCP021212D, DCR010505, INA101, ISO122, MPC506, OPA244, or OPA277

IMPORTANT NOTICE

Texas Instruments Incorporated and its subsidiaries (TI) reserve the right to make corrections, modifications, enhancements, improvements, and other changes to its products and services at any time and to discontinue any product or service without notice. Customers should obtain the latest relevant information before placing orders and should verify that such information is current and complete. All products are sold subject to TI's terms and conditions of sale supplied at the time of order acknowledgment.

TI warrants performance of its hardware products to the specifications applicable at the time of sale in accordance with TI's standard warranty. Testing and other quality control techniques are used to the extent TI deems necessary to support this warranty. Except where mandated by government requirements, testing of all parameters of each product is not necessarily performed.

TI assumes no liability for applications assistance or customer product design. Customers are responsible for their products and applications using TI components. To minimize the risks associated with customer products and applications, customers should provide adequate design and operating safeguards.

TI does not warrant or represent that any license, either express or implied, is granted under any TI patent right, copyright, mask work right, or other TI intellectual property right relating to any combination, machine, or process in which TI products or services are used. Information published by TI regarding third-party products or services does not constitute a license from TI to use such products or services or a warranty or endorsement thereof. Use of such information may require a license from a third party under the patents or other intellectual property of the third party, or a license from TI under the patents or other intellectual property of TI.

Reproduction of information in TI data books or data sheets is permissible only if reproduction is without alteration and is accompanied by all associated warranties, conditions, limitations, and notices. Reproduction of this information with alteration is an unfair and deceptive business practice. TI is not responsible or liable for such altered documentation.

Resale of TI products or services with statements different from or beyond the parameters stated by TI for that product or service voids all express and any implied warranties for the associated TI product or service and is an unfair and deceptive business practice. TI is not responsible or liable for any such statements.

Following are URLs where you can obtain information on other Texas Instruments products and application solutions:

Products

Amplifiers	amplifier.ti.com
Data Converters	dataconverter.ti.com
DSP	dsp.ti.com
Interface	interface.ti.com
Logic	logic.ti.com
Power Mgmt	power.ti.com
Microcontrollers	microcontroller.ti.com

Applications

Audio	www.ti.com/audio
Automotive	www.ti.com/automotive
Broadband	www.ti.com/broadband
Digital control	www.ti.com/digitalcontrol
Military	www.ti.com/military
Optical Networking	www.ti.com/opticalnetwork
Security	www.ti.com/security
Telephony	www.ti.com/telephony
Video & Imaging	www.ti.com/video
Wireless	www.ti.com/wireless

TI Worldwide Technical Support

Internet

TI Semiconductor Product Information Center Home Page
support.ti.com

TI Semiconductor KnowledgeBase Home Page
support.ti.com/sc/knowledgebase

Product Information Centers

Americas

Phone	+1(972) 644-5580	Fax	+1(972) 927-6377
Internet/Email	support.ti.com/sc/pic/americas.htm		

Europe, Middle East, and Africa

Phone			
Belgium (English)	+32 (0) 27 45 54 32	Netherlands (English)	+31 (0) 546 87 95 45
Finland (English)	+358 (0) 9 25173948	Russia	+7 (0) 95 7850415
France	+33 (0) 1 30 70 11 64	Spain	+34 902 35 40 28
Germany	+49 (0) 8161 80 33 11	Sweden (English)	+46 (0) 8587 555 22
Israel (English)	1800 949 0107	United Kingdom	+44 (0) 1604 66 33 99
Italy	800 79 11 37		
Fax	+(49) (0) 8161 80 2045		
Internet	support.ti.com/sc/pic/euro.htm		

Japan

Fax			
International	+81-3-3344-5317	Domestic	0120-81-0036
Internet/Email			
International	support.ti.com/sc/pic/japan.htm		
Domestic	www.tij.co.jp/pic		

Asia

Phone			
International	+886-2-23786800		
Domestic	Toll-Free Number		
Australia	1-800-999-084	New Zealand	0800-446-934
China	800-820-8682	Philippines	1-800-765-7404
Hong Kong	800-96-5941	Singapore	800-886-1028
Indonesia	001-803-8861-1006	Taiwan	0800-006800
Korea	080-551-2804	Thailand	001-800-886-0010
Malaysia	1-800-80-3973		
Fax	886-2-2378-6808	Email	tiasia@ti.com
Internet	support.ti.com/sc/pic/asia.htm		ti-china@ti.com

C011905

Safe Harbor Statement: This publication may contain forward-looking statements that involve a number of risks and uncertainties. These "forward-looking statements" are intended to qualify for the safe harbor from liability established by the Private Securities Litigation Reform Act of 1995. These forward-looking statements generally can be identified by phrases such as "TI or its management believes," "expects," "anticipates," "foresees," "forecasts," "estimates" or other words or phrases of similar import. Similarly, such statements herein that describe the company's products, business strategy, outlook, objectives, plans, intentions or goals also are forward-looking statements. All such forward-looking statements are subject to certain risks and uncertainties that could cause actual results to differ materially from those in forward-looking statements. Please refer to TI's most recent Form 10-K for more information on the risks and uncertainties that could materially affect future results of operations. We disclaim any intention or obligation to update any forward-looking statements as a result of developments occurring after the date of this publication.

Trademarks: All trademarks are the property of their respective owners.

Mailing Address: Texas Instruments
Post Office Box 655303
Dallas, Texas 75265

© 2005 Texas Instruments Incorporated