



# PRO3582: Projeto Integrado de Sistemas de Produção

Aula 08 - 2023

Prof. Dr. André Leme Fleury

Prof. Dr. Artur Vilas Boas

---

# Objetivos

Viabilizar aos participantes uma experiência de desenvolvimento de produtos, serviços e experiências “centradas no usuário”:

- Compreender e caracterizar o público alvo
- Identificar necessidades e oportunidades de criação
- Desenvolver integradamente protótipos de produtos e serviços utilizando metodologias ativas

Estabelecer e implementar uma nova abordagem para desenvolvimento de soluções, capaz de resultar em experiências que superam as expectativas dos participantes

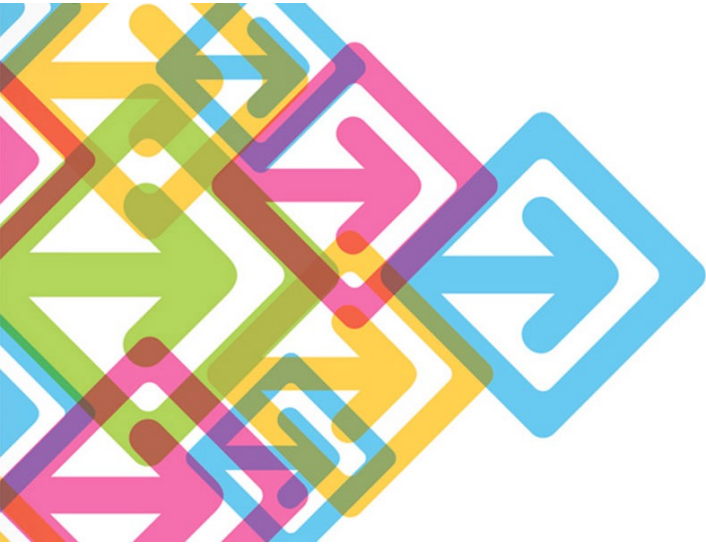

---

Design  
Thinking  
Criação

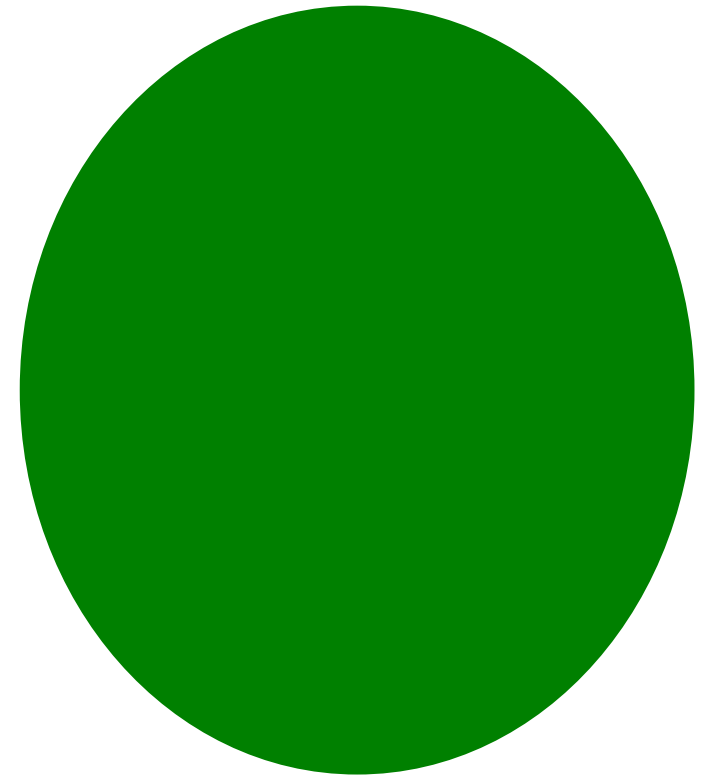



# Método

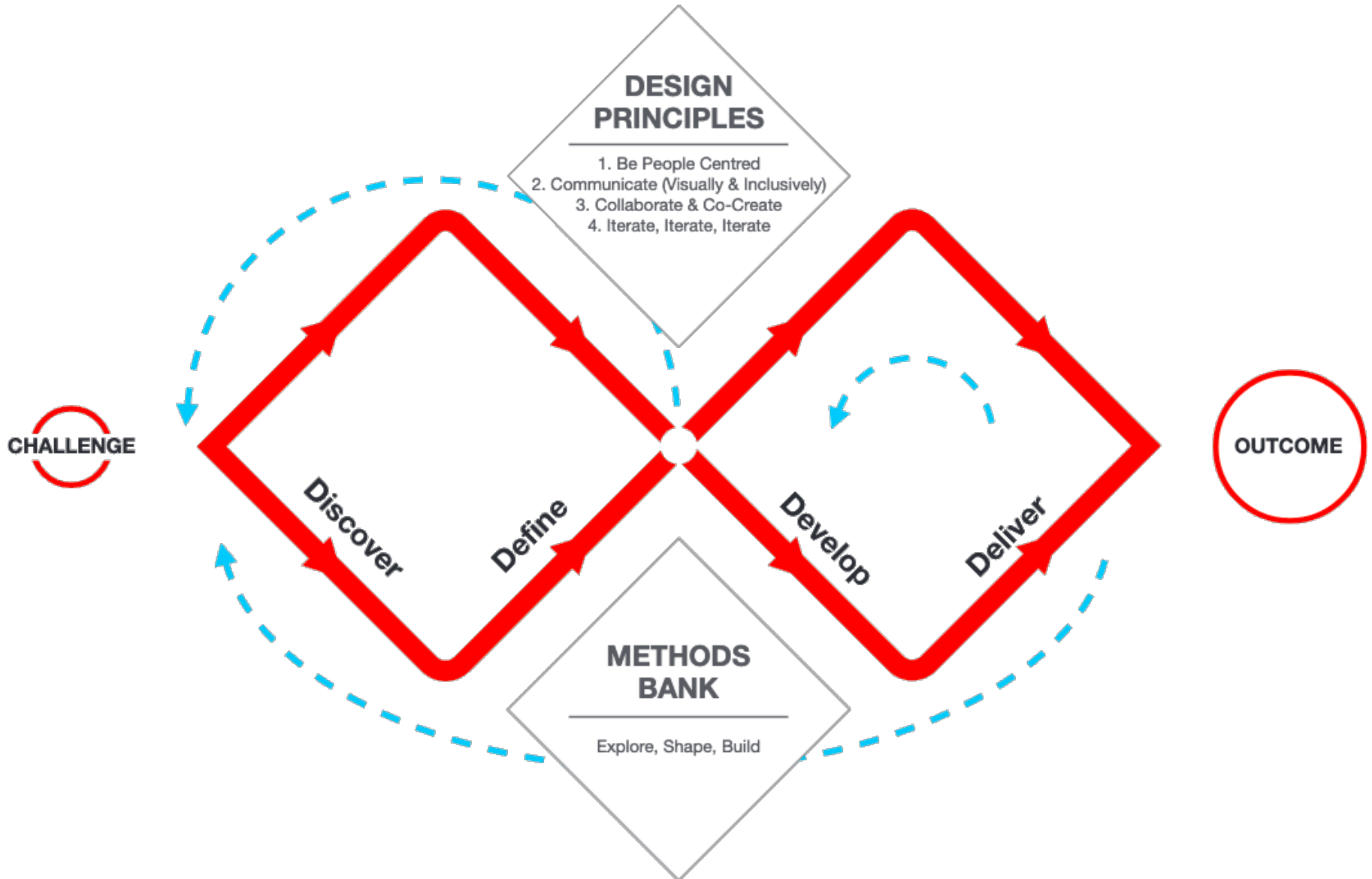

## Como Nós Podemos (CNP)

- Desafio: Redesenhar a experiência dos passageiros na sala de espera de um aeroporto internacional
- POV: A mãe de três crianças, que correm apressadamente pelo aeroporto enquanto aguardam horas no saguão, precisa entreter suas crianças porque as brincadeiras das crianças estão enervando bastante os demais passageiros, já irritados com a longa espera.



# Como Nós Podemos (CNP)

- Amplificar o bom
- CNP usar a energia das crianças para entreter os demais passageiros?
- Remover o mau
- CNP remover as crianças dos demais passageiros?
- Explorar os opostos
- CNP fazer a espera a parte mais excitante da viagem?
- Questionar os pressupostos
- CNP remover inteiramente a espera num aeroporto?
- Buscar adjetivos
- CNP fazer a correria das crianças agradável ao invés de irritante



---

# Como Nós Podemos (CNP)

- Identificar recursos inesperados
- CNP utilizar o tempo livre dos passageiros para agilizar o processo de embarque?
- Criar uma analogia com outra necessidade ou contexto
- CNP fazer o aeroporto como um spa? Como um playground?
- Mudar o desafio do POV
- CNP fazer um aeroporto um local que as crianças desejem ir?
- Quebrar o POV em partes
- CNP entreter as crianças? CNP acalmar a mãe? CNP entreter os demais passageiros?



# Como Nós Podemos (CNP)

- Amplificar o bom
- Remover o mau
- Explorar os opostos
- Questionar os pressupostos
- Buscar adjetivos
- Identificar recursos inesperados
- Criar uma analogia com outra necessidade ou contexto
- Mudar o desafio do POV
- Quebrar o POV em partes



---

# Brainwriting

- Numa mesa com uma folha contendo o problema a ser resolvido no cabeçalho.
- Alguns minutos para cada um escrever as sugestões
- O moderador deve recolher as folhas e misturá-las
- Sem conversa e sem discussão.
- O moderador define o número de vezes que será repetido.

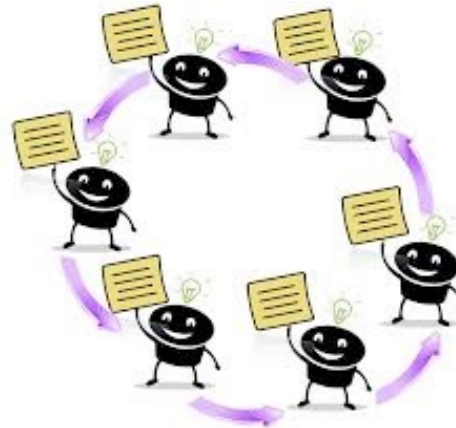

# Crazy 8s

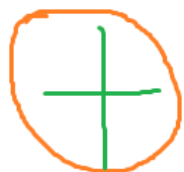

Login  
Cadastro

Esqueci minha senha

Chat

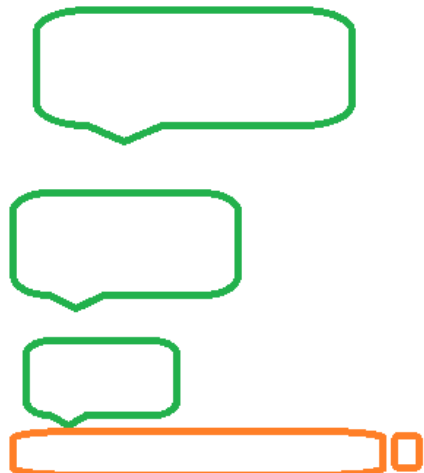

Perfil  Adicionar \$

Auxílio via chat

Atendimento marcado online

Chamada de  
Emergência

Vídeo chamada Emergência



Buscar profissional por  
especialidade.

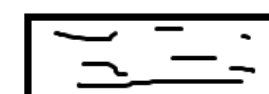
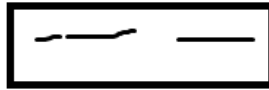

Clinicas



Ficha do veterinário



Atende em tal  
lugar.

especialista em tal coisa.

Atende na região de tal e tal

Chamar

Clinica perto de você

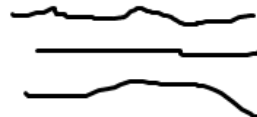
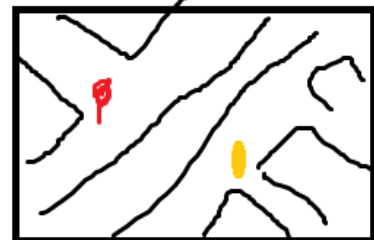

# Brainstorming

- Uma conversa por vez
- Quantidade e não qualidade
- Construa sobre as ideias dos outros
- Encoraje as ideias malucas
- Seja visual
- Mantenha o foco
- “Sim, e...” ao invés de “sim, mas..”
- Não faça “críticas nem julgamentos (não é DR)



# Brainstorming Reverso

- Seleccionem 2 a 3 CNPs
- Façam a pergunta da CNP de forma reversa. Ex:
  - Como podemos melhorar a experiência numa sala de espera de um hospital?
  - Como podemos aborrecer ainda mais as pessoas na sala de espera de um hospital?
  - Ao invés de resolver um problema, queremos criar um problema.

# Escolha das ideias

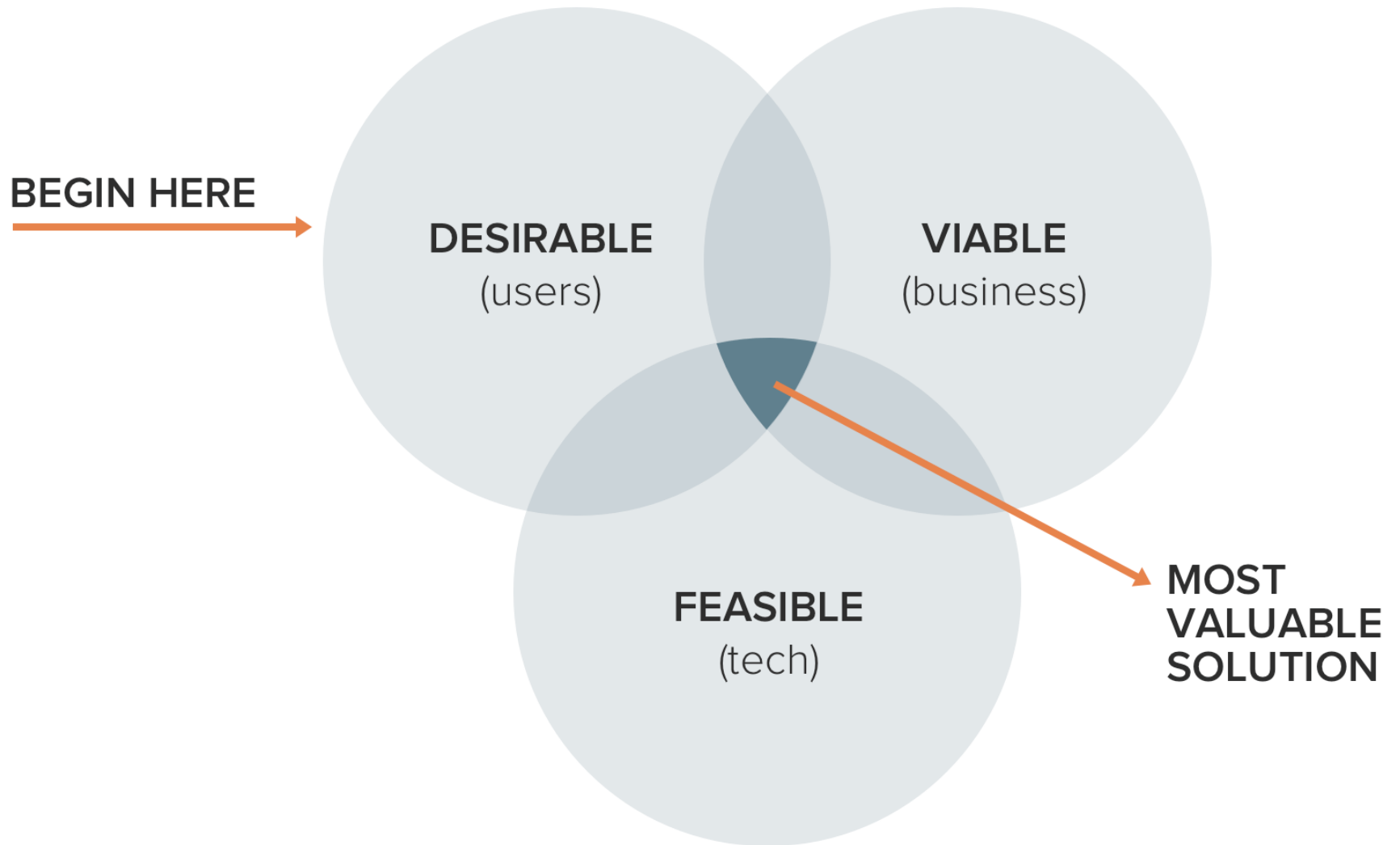

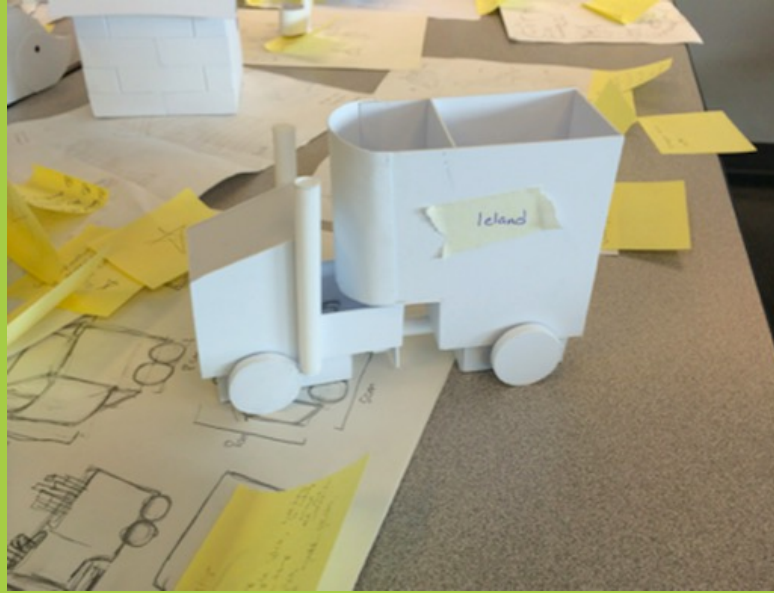

Criação

# ME310

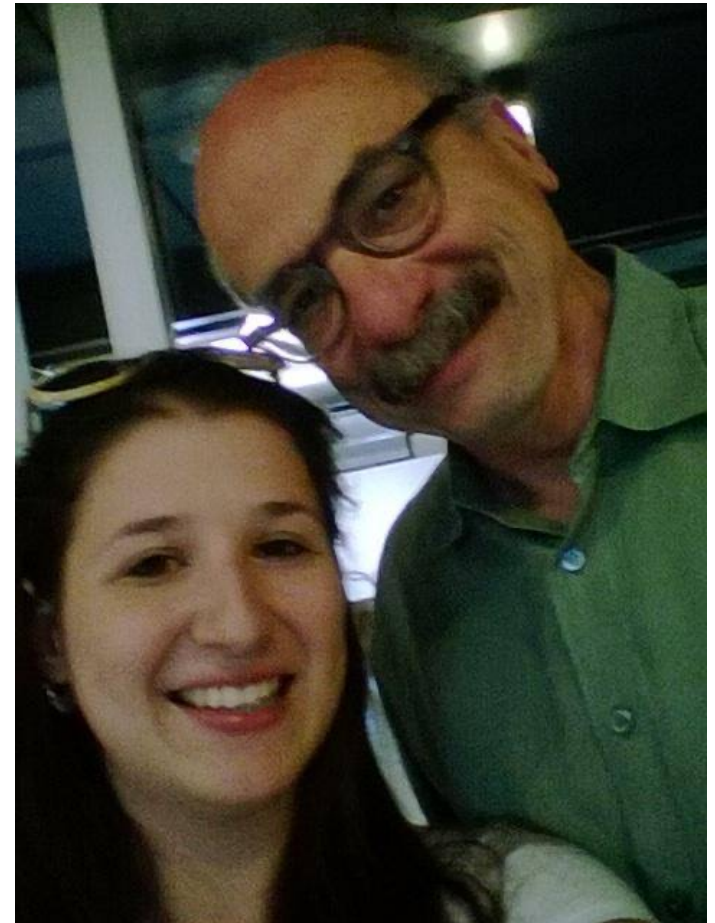
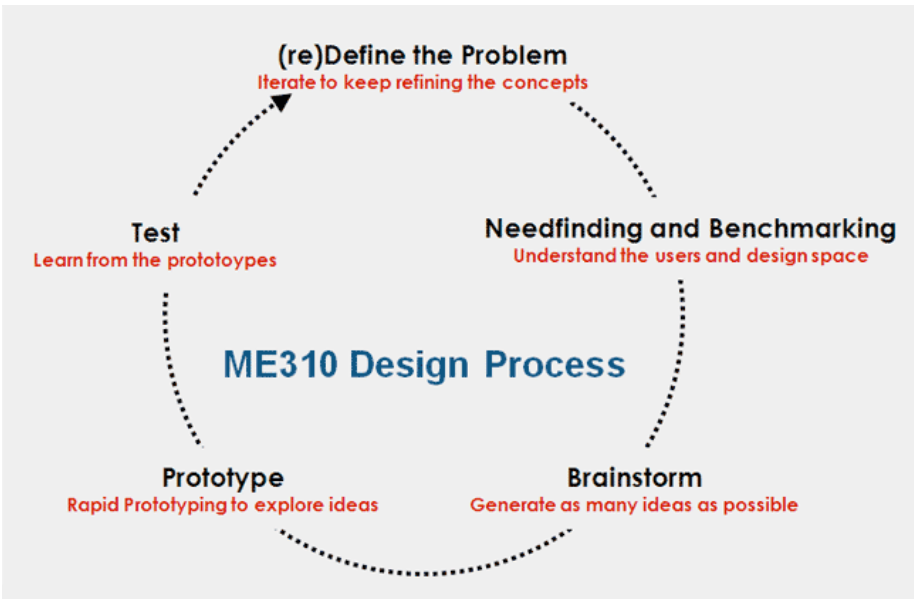

ME310

## Ambientes





# ME310

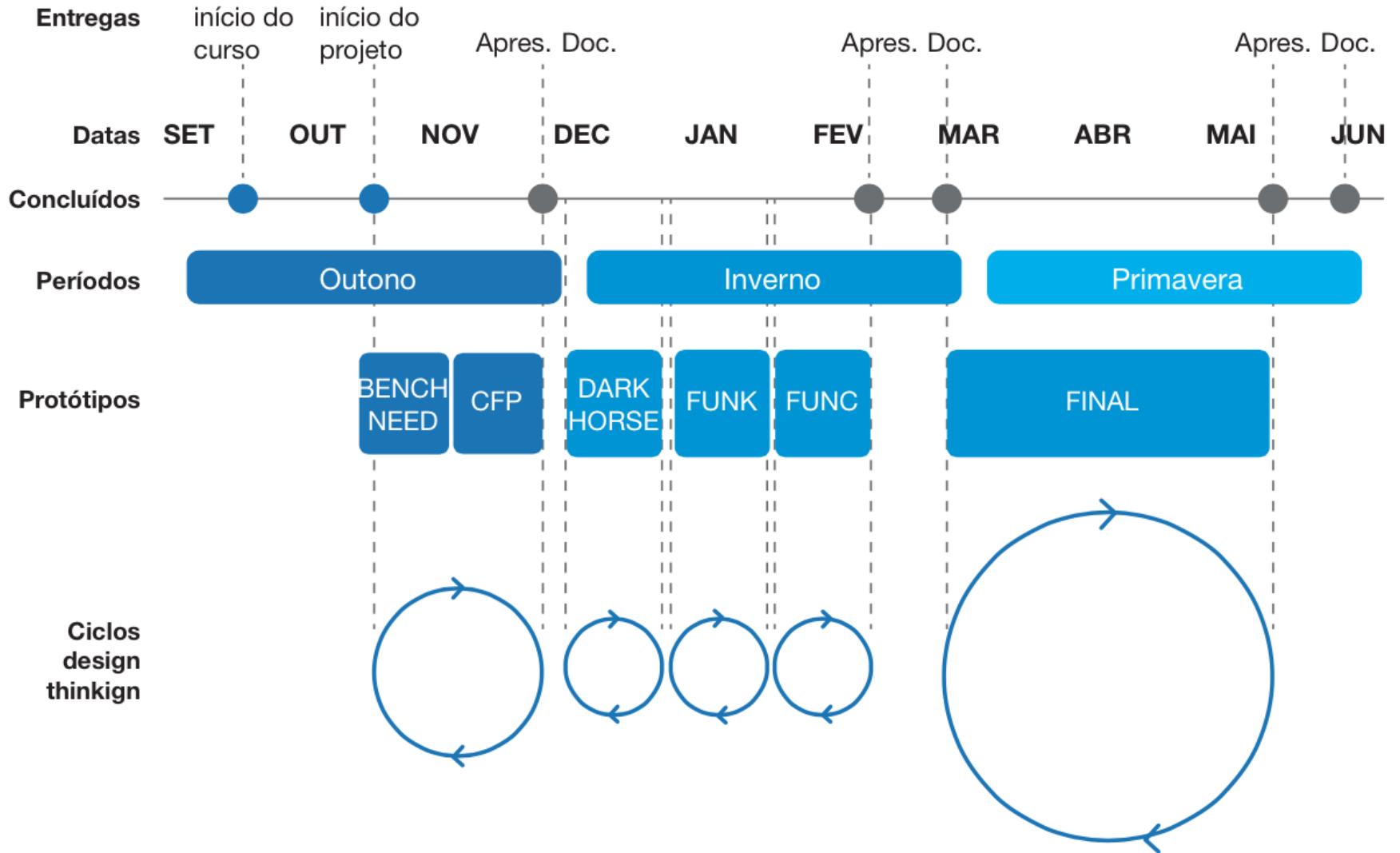

# ME310

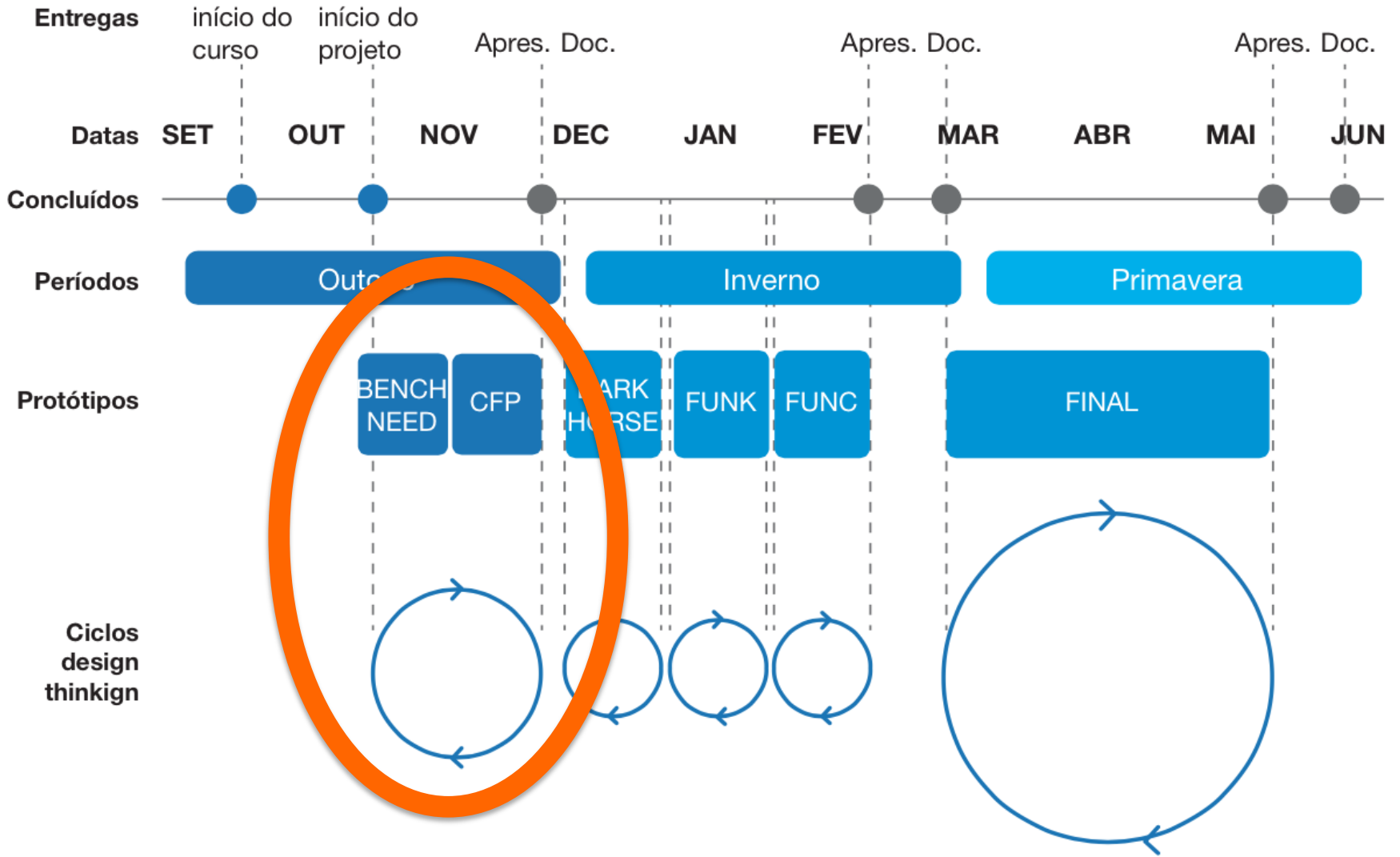



---

ME310

## Benchmarks



---

# ME310

## Benchmarks



# ME310

## Patentes

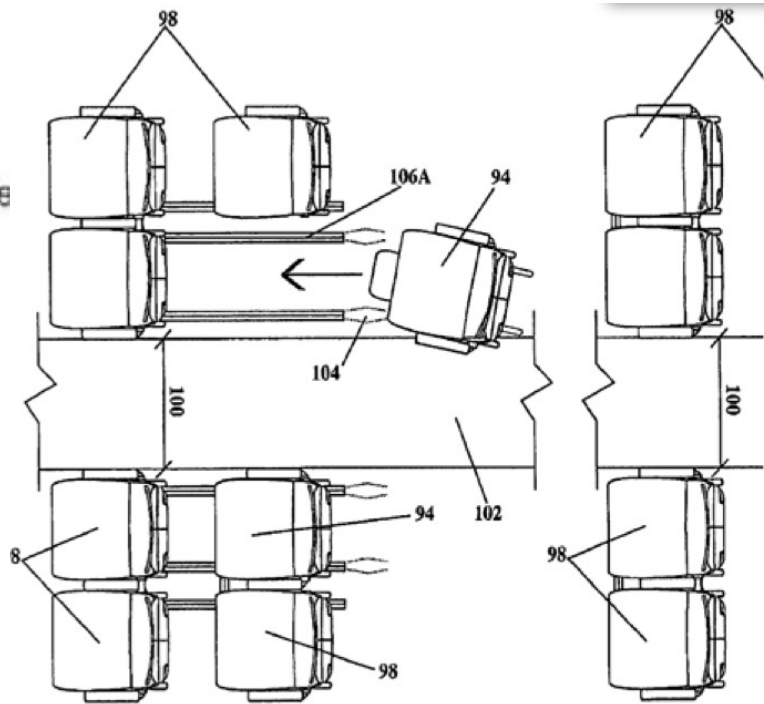
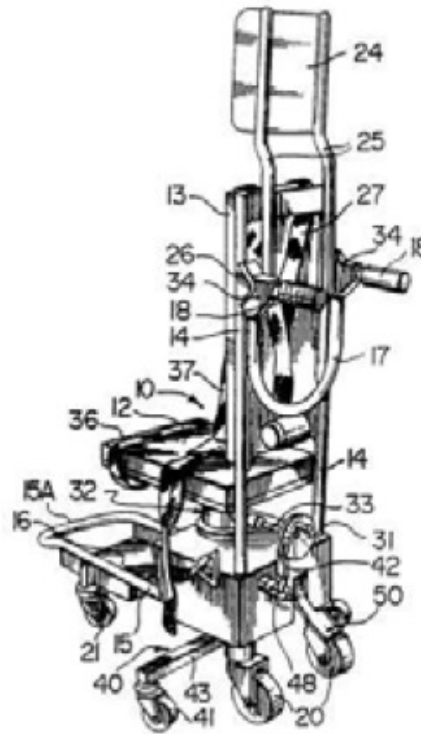
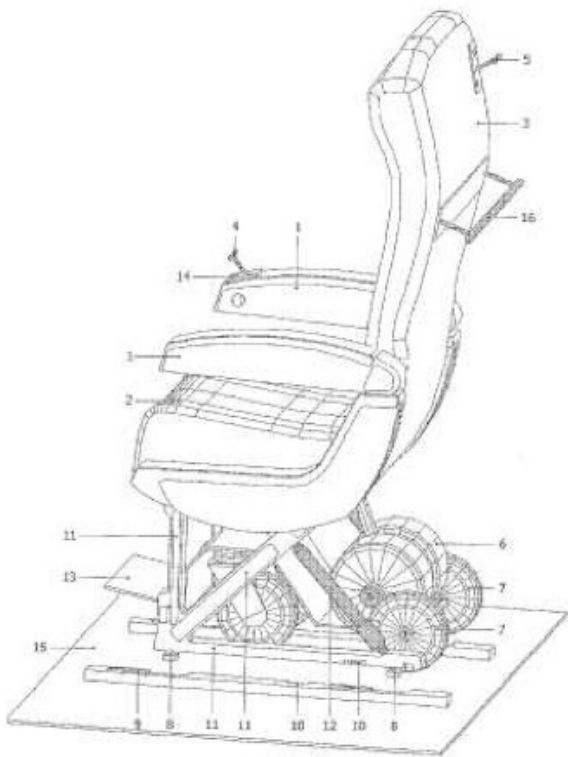

# ME310

## Observações

Aeroporto	check-in	falta de indicação do terminal terminais eletronicos não adaptados balcão alto falta de local de espera antes da segurança
	segurança	desconforto ao remover peças de roupa pressão para ser rápido
	portão	sistema de som ruim longas distancias falta de treinamento dos funcionarios
	assentos	falta de local para lixo não ergonômico
	WC	falta local para espera não adaptado
Avião	sinalização	numeros confusos e pequenos som ruim
	bin	muito auto para pessoas baixas risco da mala cair ao abrir
	cintos	pequeno para pessoas obesas
	comida	bandeja escorregadia
	controles	não acessível para todos pouco intuitivo
Transporte até o aeroporto	trem	falta de locais para segurar sem painéis mostrando a próxima estação poucos locais para malas bilhetes comprados em máquinas não adaptadas sem pessoas auxiliando
	onibus	sem pessoas auxiliando local para por as malas não acessível
	taxi	não existe em cidades pequenas

Primeiras Ideias

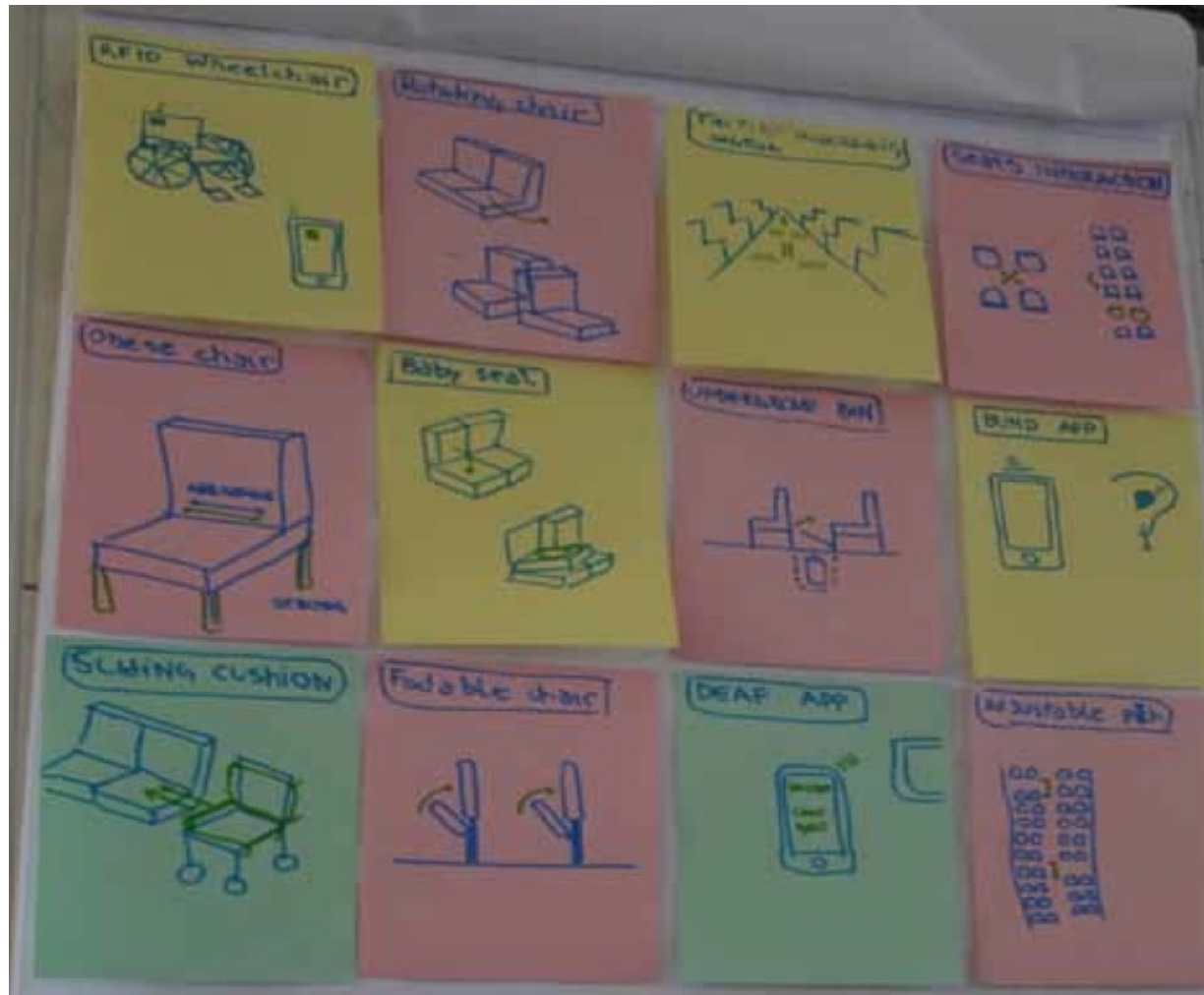



---

ME310

### Protótipo Seat on Rails



ME310

## Protótipo Aplicativo Celular



---

ME310

## Protótipo Robô Bagagem



# ME310

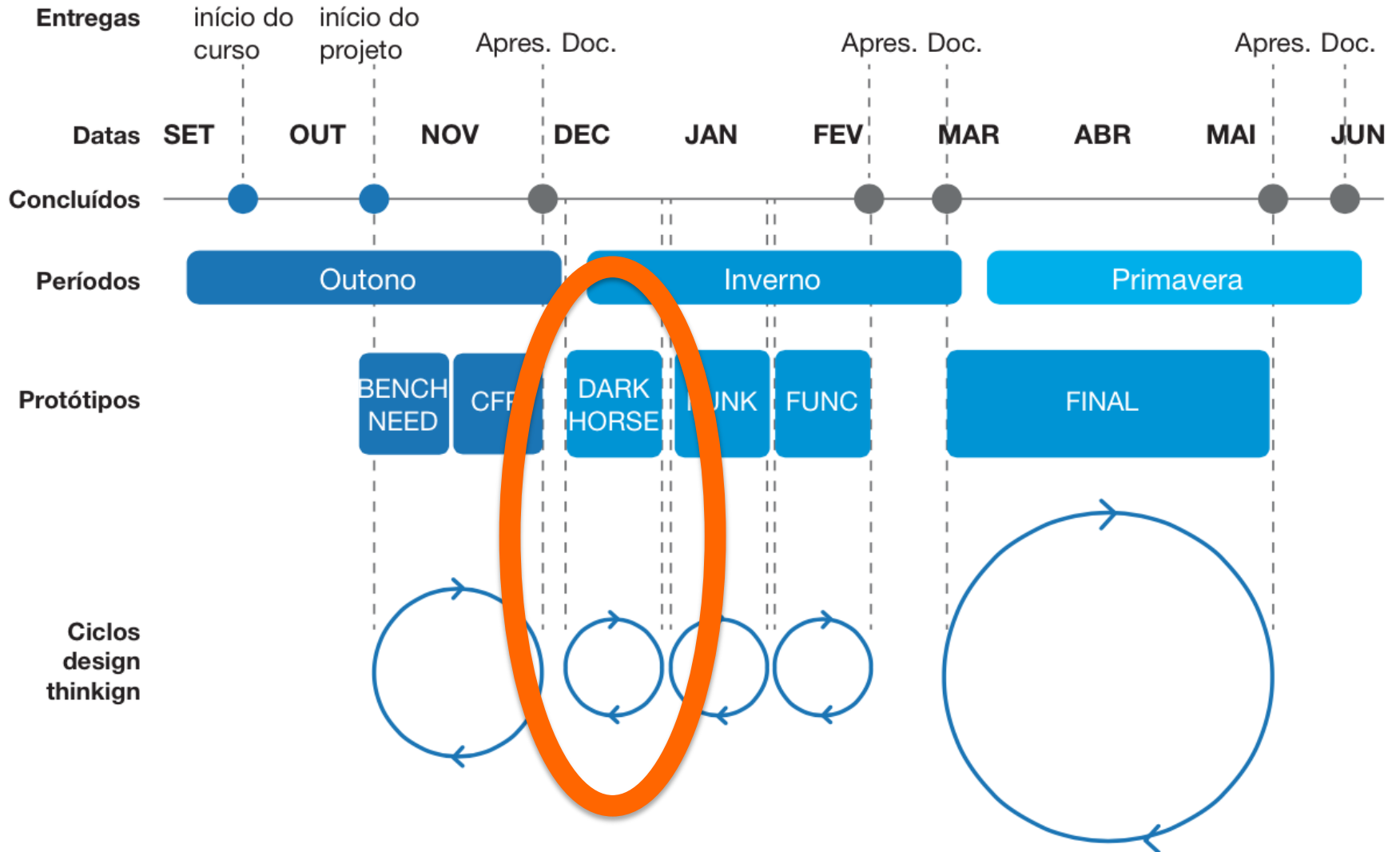

ME310

## Protótipo Toaleta Giratório

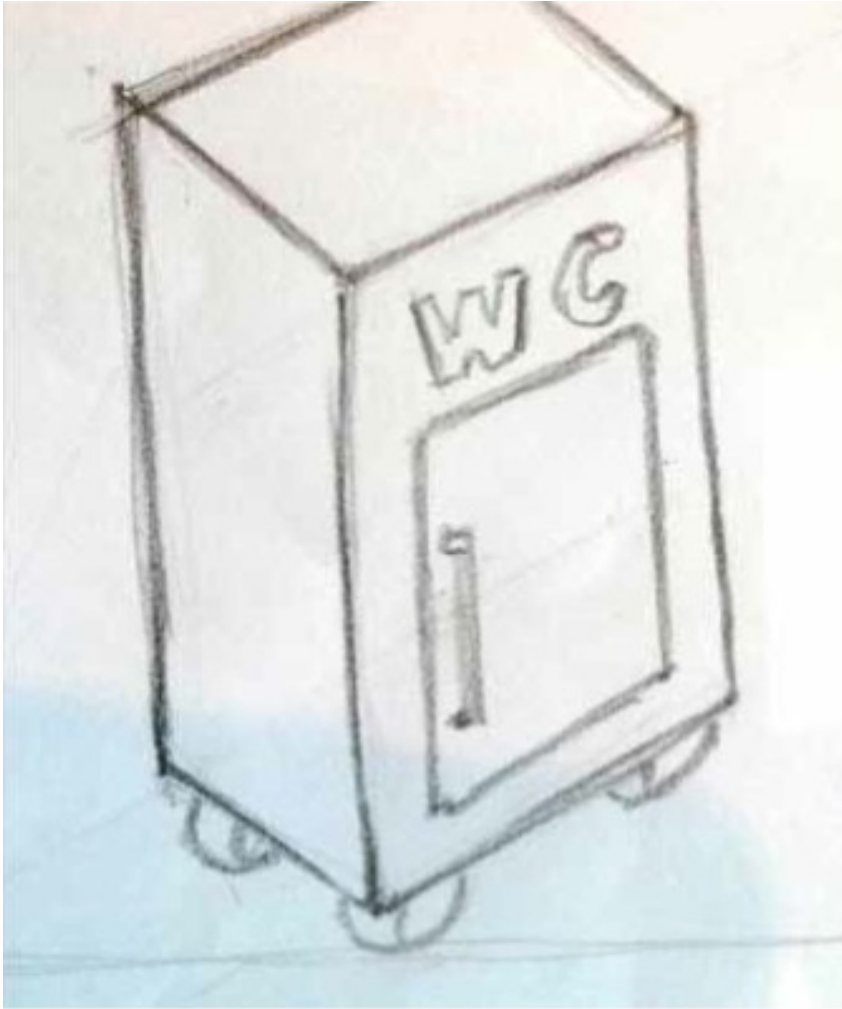

# ME310

## Protótipo Toaleta Giratório

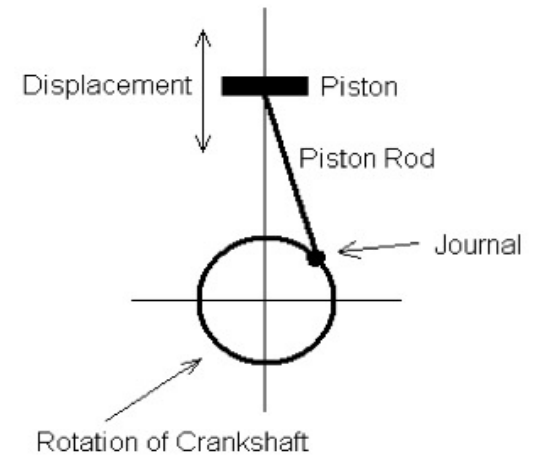

ME310

## Protótipo Toaleta Giratório

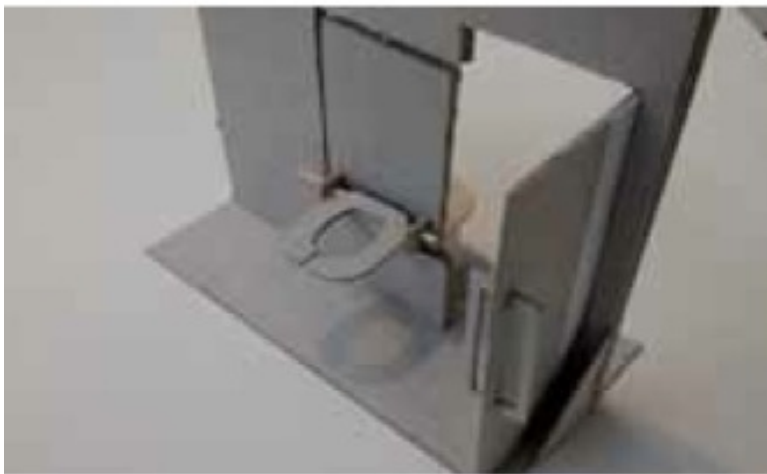

ME310

## Protótipo Toaleta Giratório





# ME310

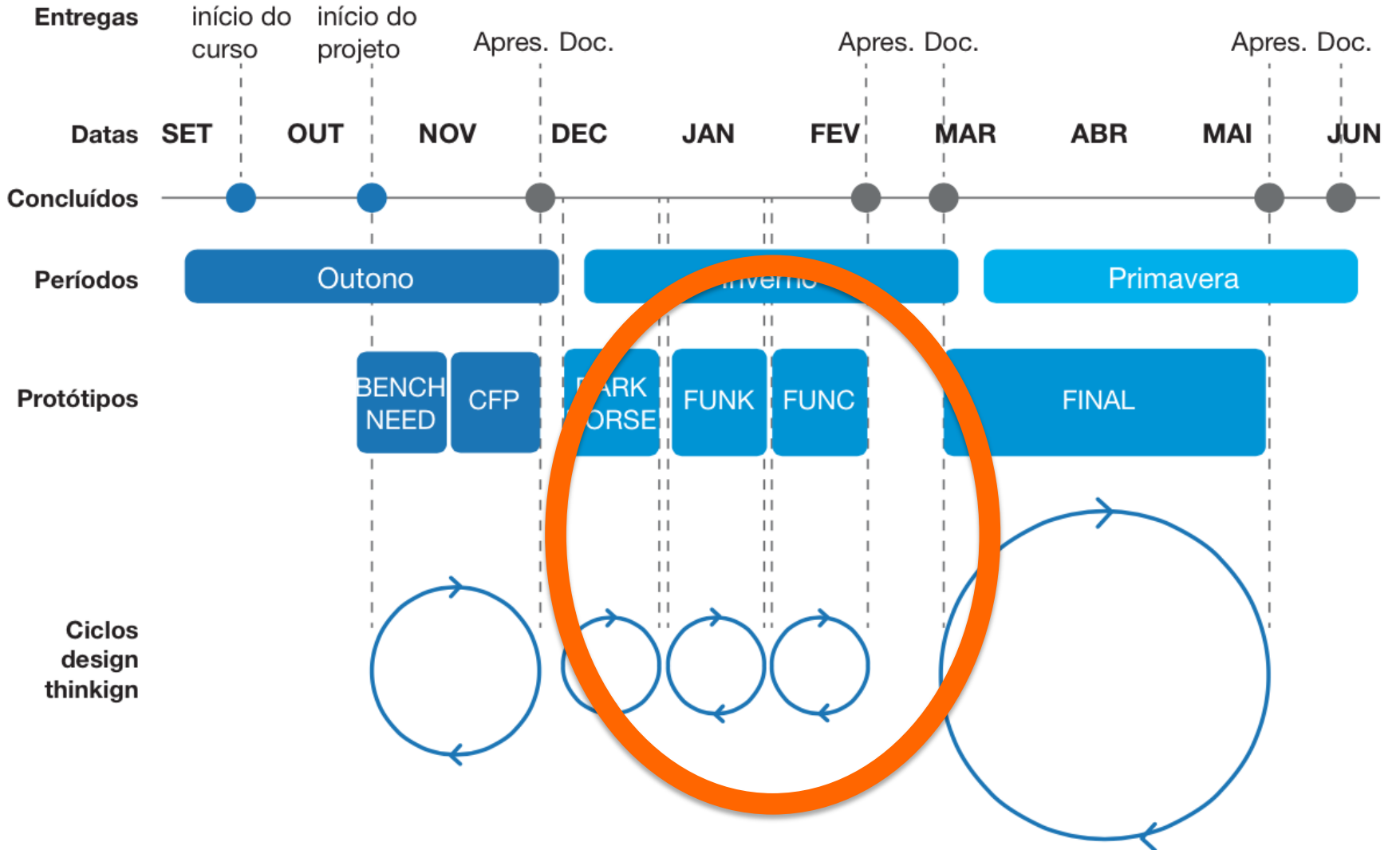

# ME310

## Protótipo Assento Especial



# ME310

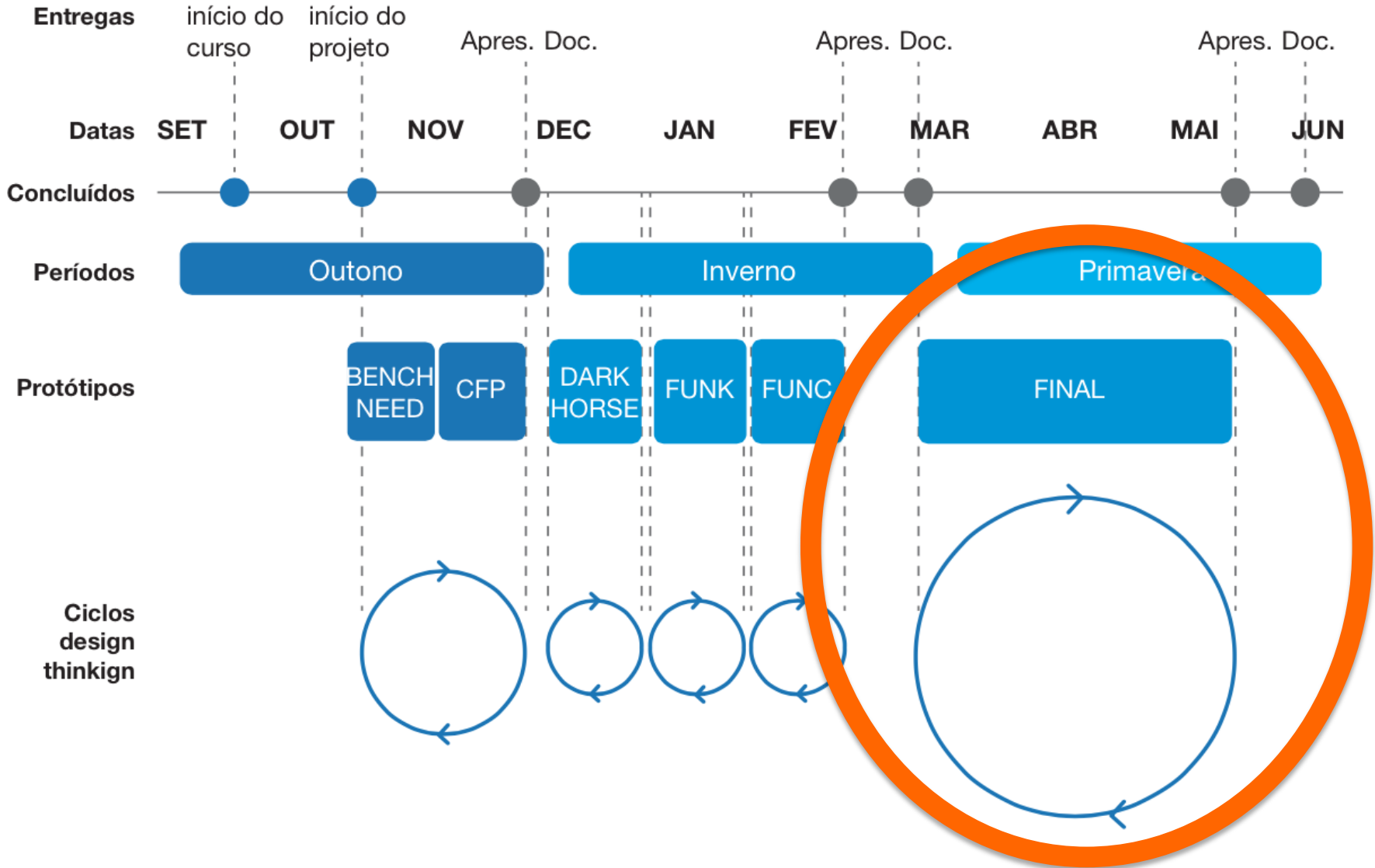

ME310

## Protótipo Assento Especial



ME310

## Protótipo Assento Especial



**Tiras de segurança**

**Alças de direção**

**Apoio frontal**

**Travas da almofada**

**Almofada**

**Mecanismo lateral**

**Estrutura**

**Apoio de pés**

ME310

## Apresentação Final

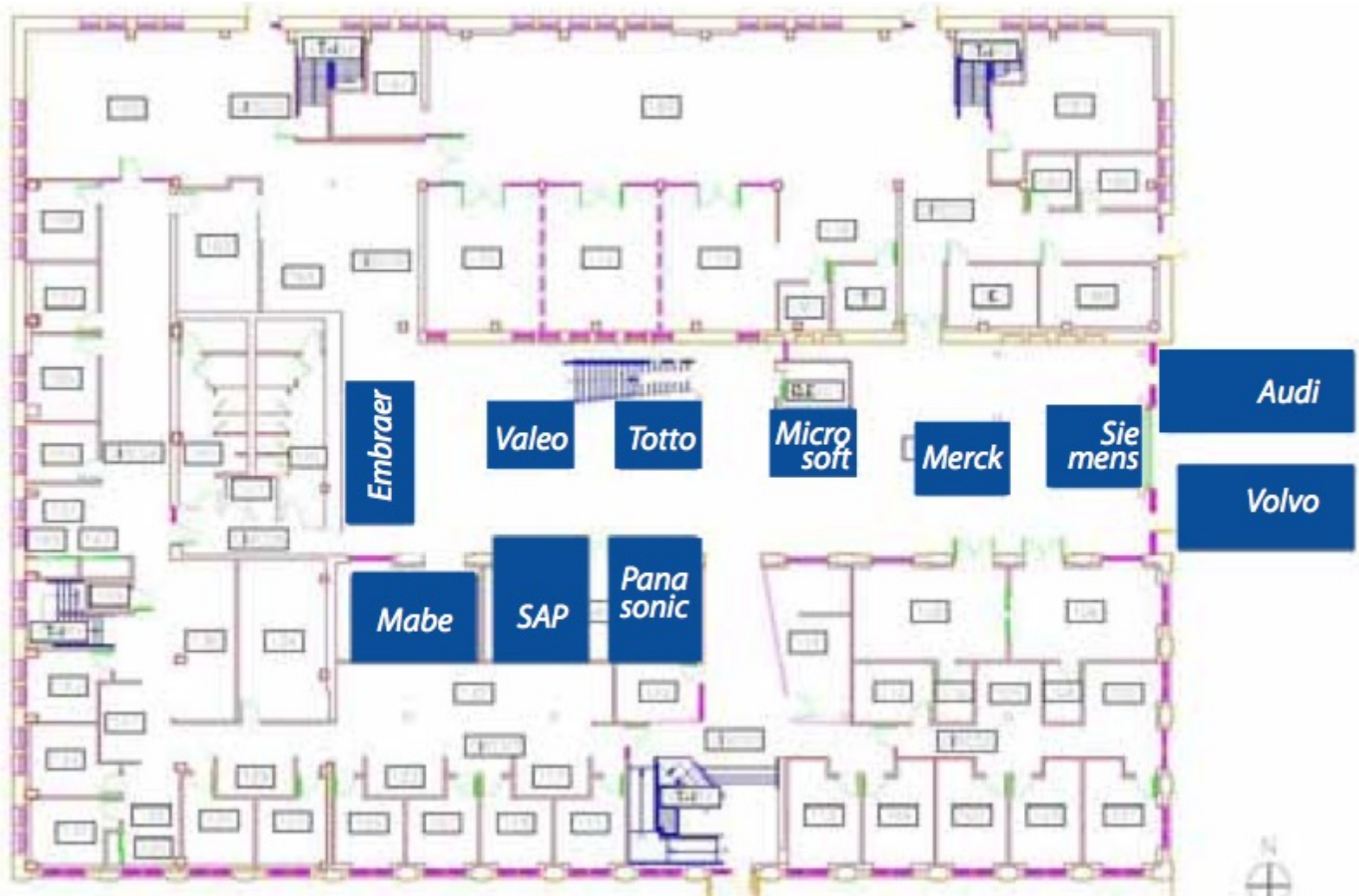

ME310

## Apresentação Final

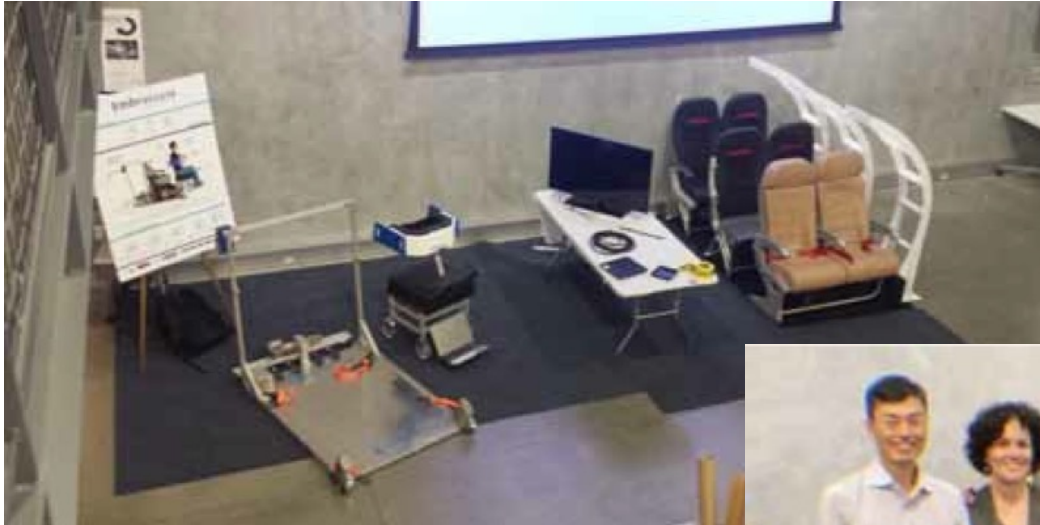

---

# Protótipo de Baixa Resolução

## Transformando ideias em realidade



**Errar cedo**

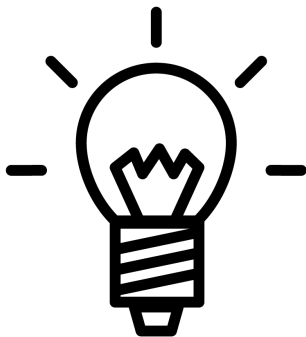

**Construir novas ideias a partir de problemas encontrados**



# Protótipo de Baixa Resolução

## Importância para o sucesso do projeto

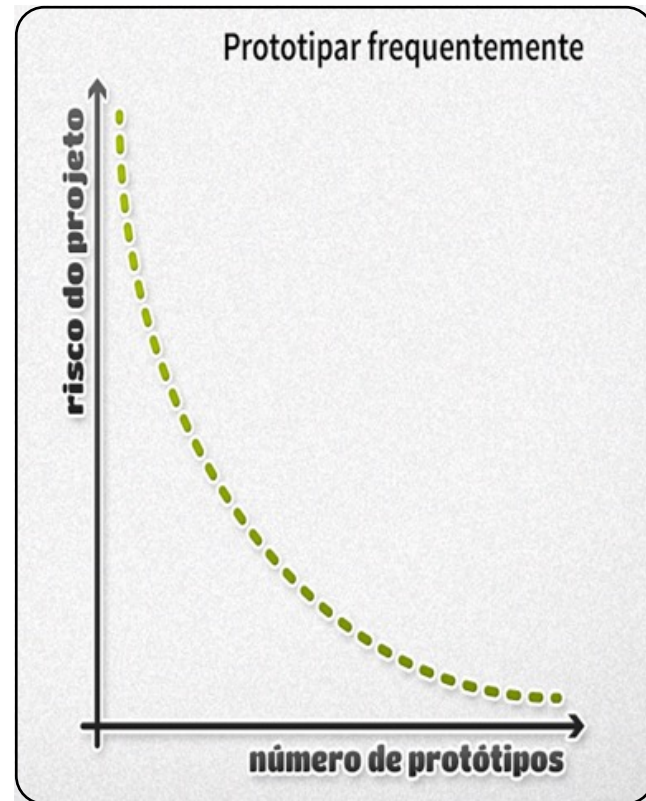
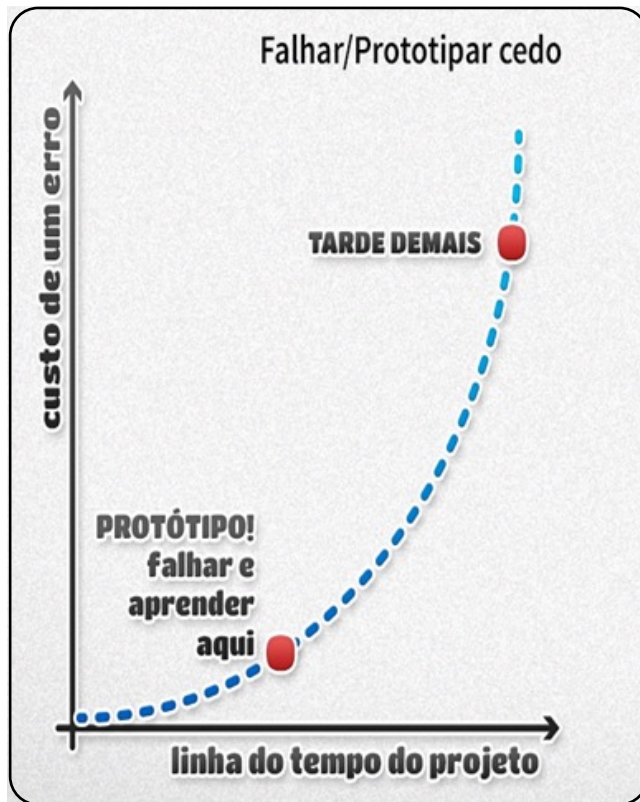

# Protótipo de Baixa Resolução

## O protótipo deve ser

- Simples, rápido e deve acontecer cedo
- Serve para responder perguntas: desejável, útil, fácil de usar, viável, ergonômico, possível?
- Gera mais perguntas
- Cria um diálogo interno sobre um conceito e o processo de projeto (design)

# Protótipos de Produtos



---

# Sketches



# Sketches

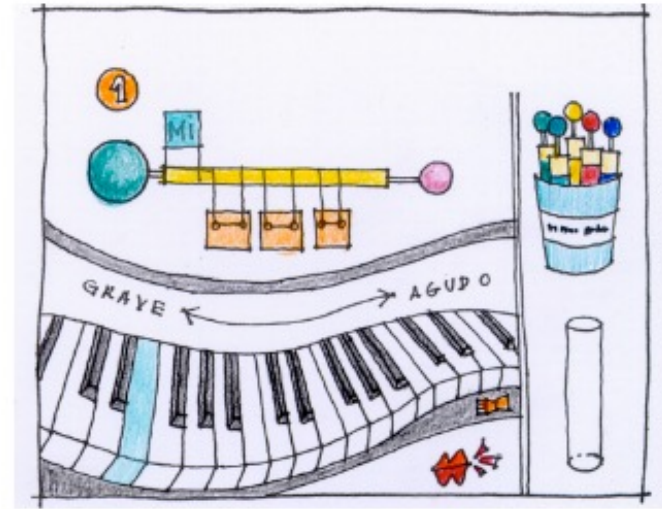
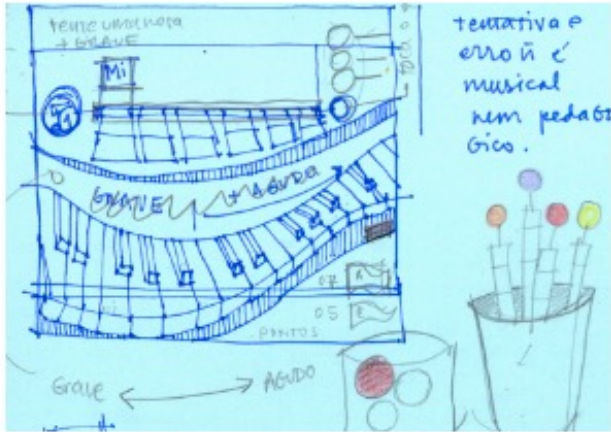

# Sketches

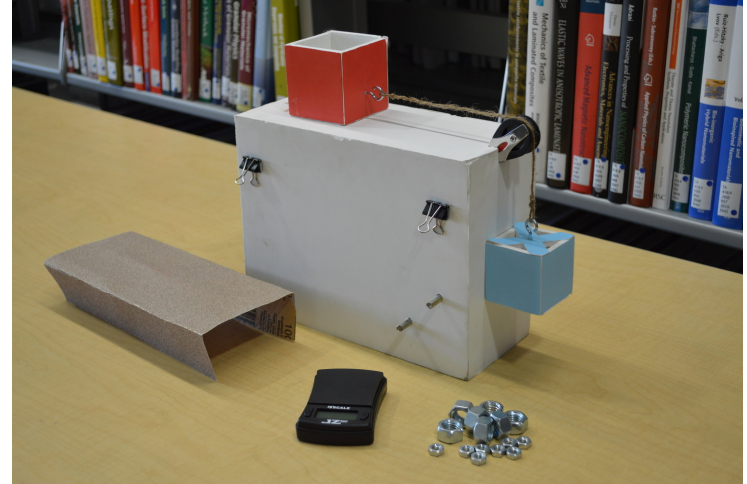
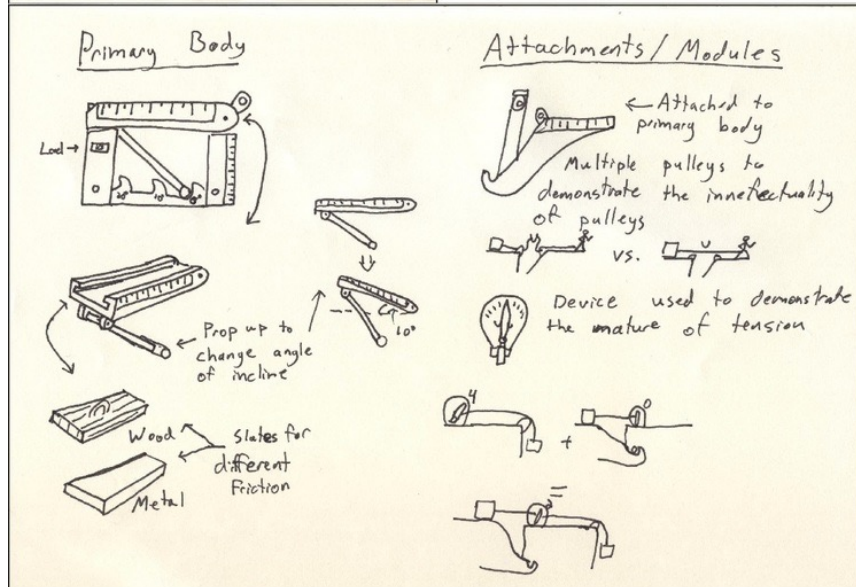
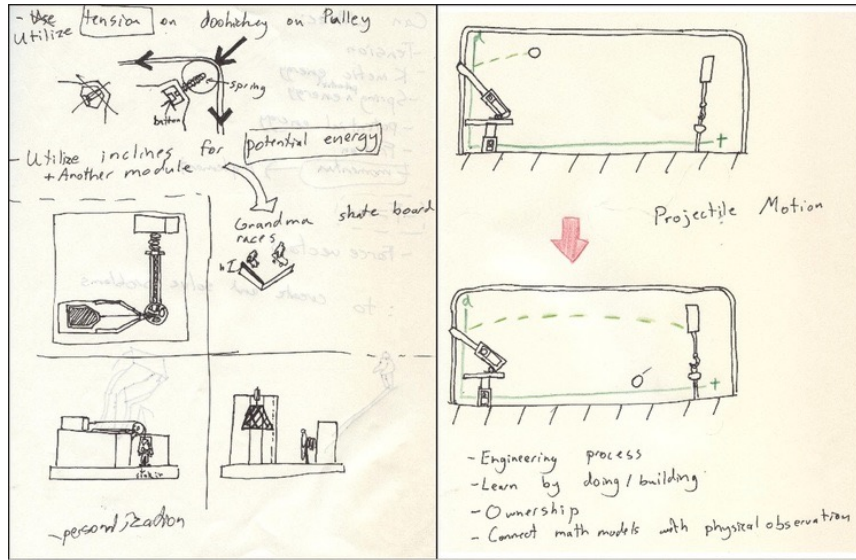

# Modelos



## Modelo em escala reduzida





# Modelo em escala real



Projeto cenografia Nave Catavento Cultural

---

# Protótipos



# Protótipos de Productos



# Protótipos de Serviços - Storyboards

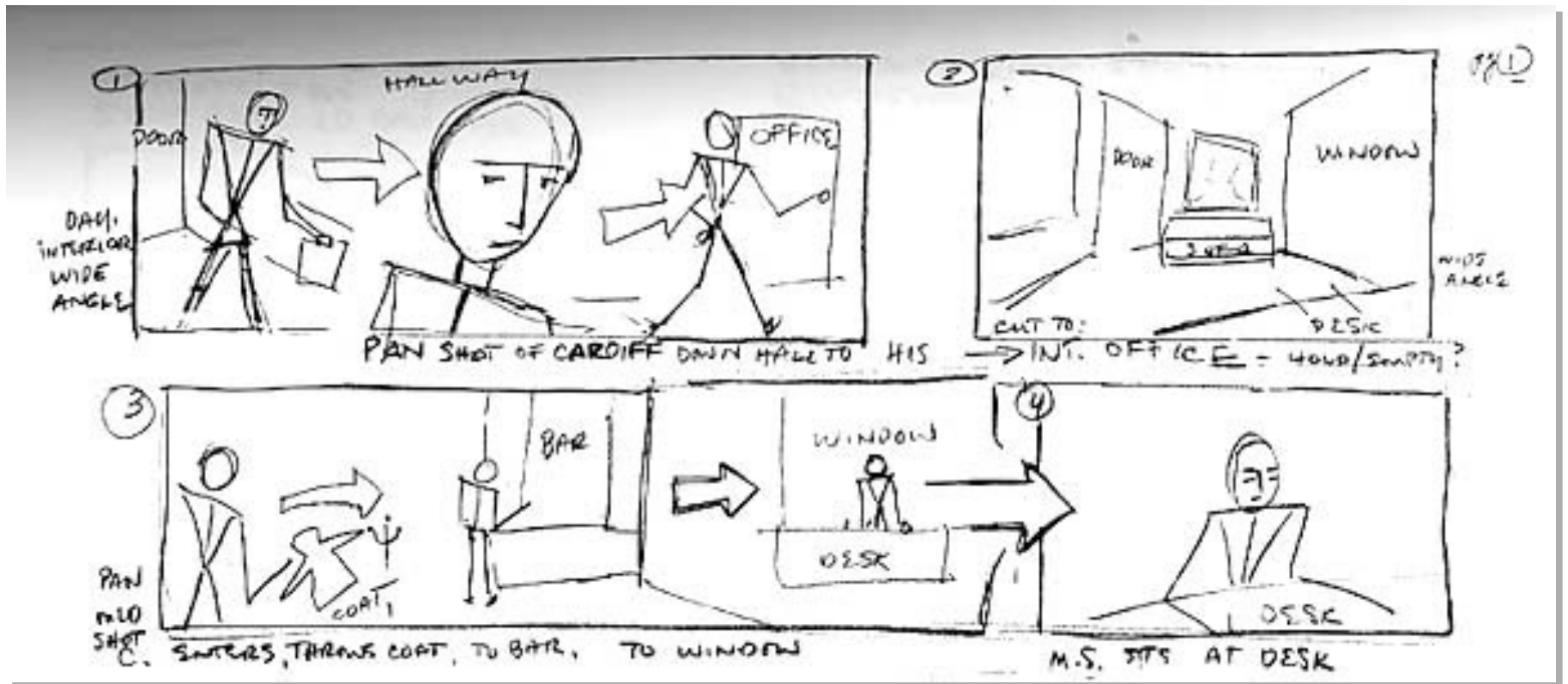

# Protótipos de Serviços – Jornada do Usuário

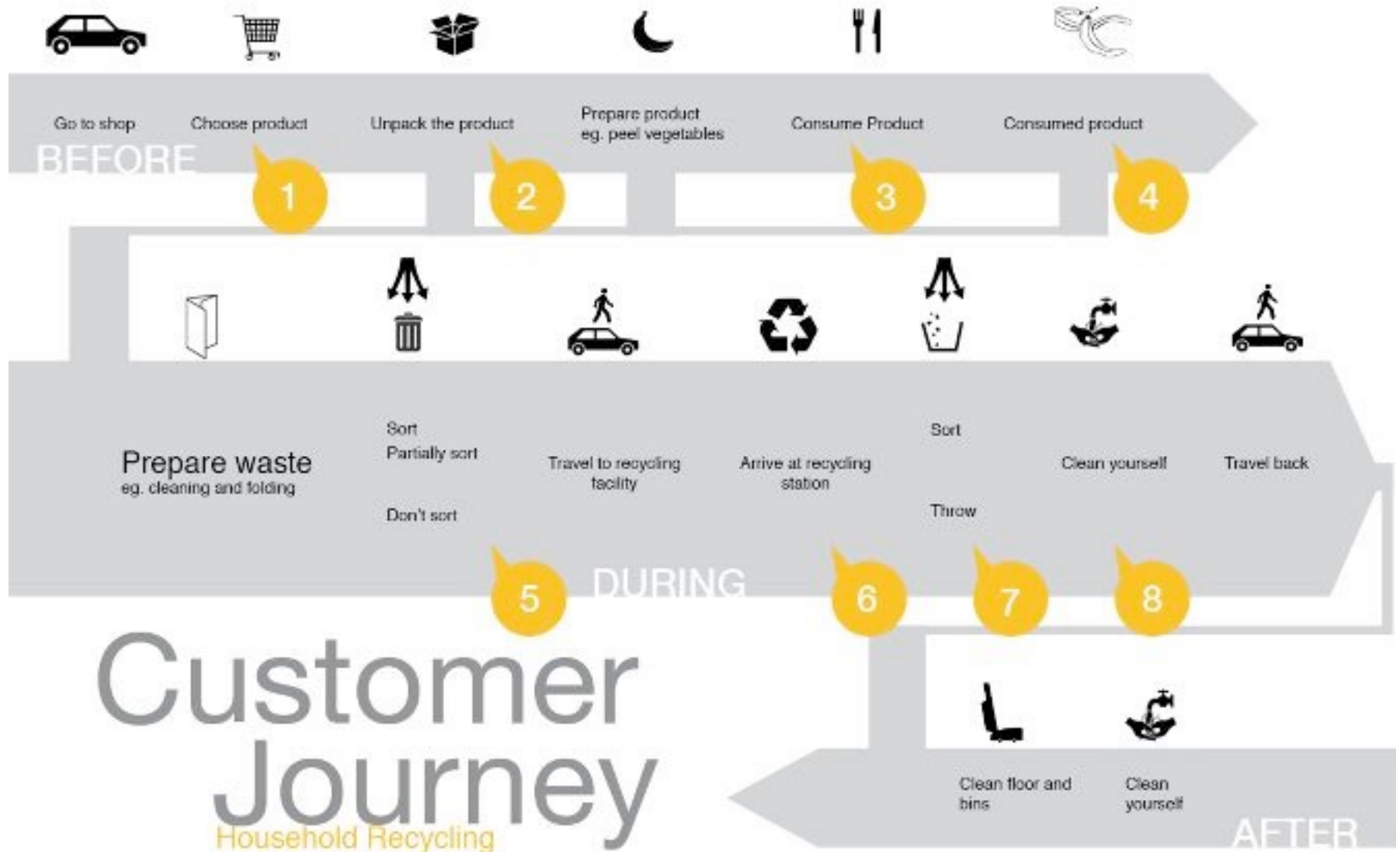

# Protótipos de Serviços – Blueprint do Serviço

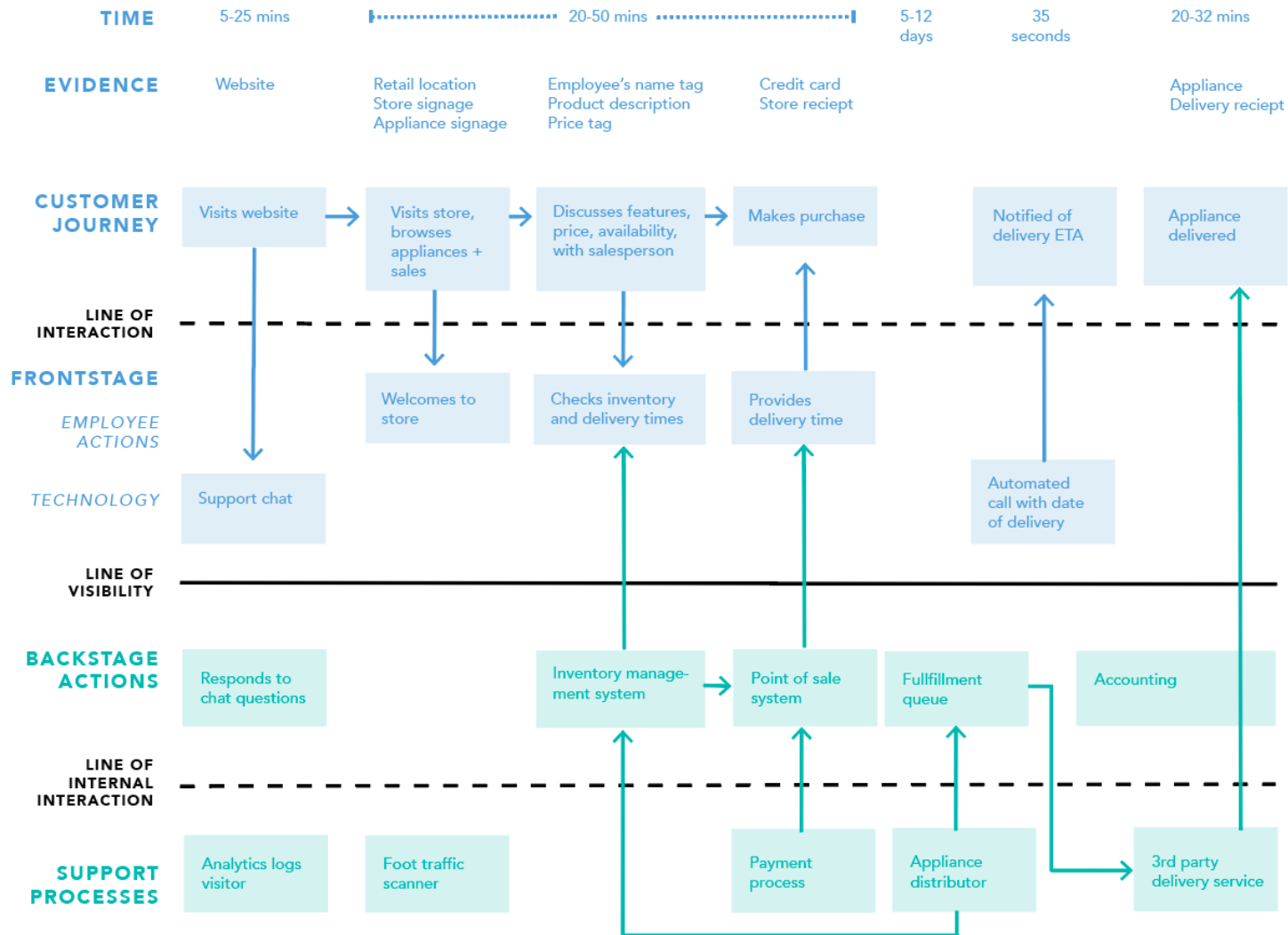

# Protótipos de Serviços – Mindmaps

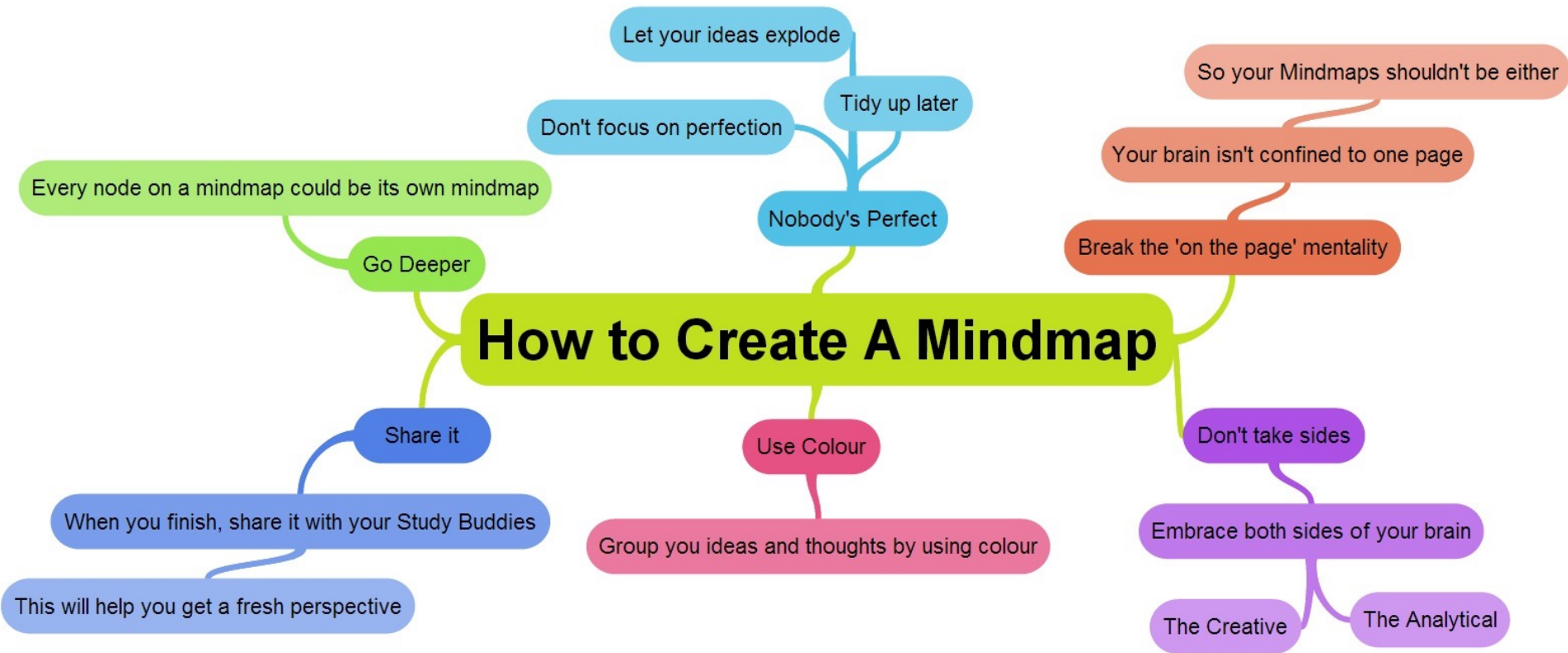





## Protótipos de Serviço – Imagem do Serviço



# Protótipos de Serviço - Pôster

The image displays three posters for the SHAREWAY service, arranged horizontally. Each poster features a black and white photograph of a person, a quote, and the service name in large green letters. Below the name is the slogan 'sempre | sicuramente' and a description of the service as a free, safe transport service for people.

- Post 1:** Features Anna, 65 anni, with the quote 'dove mi pare.' The service name is **REWAY**.
- Post 2:** Features Gino, 72 anni, with the quote 'Ti va un caffè in centro?' The service name is **SHAREWAY**.
- Post 3:** Features a young woman with the quote 'Autostop? No,'. The service name is **SHAREL**.

Each poster includes the following text at the bottom:  
sempre | sicuramente  
un servizio gratuito per il trasporto di persone per dare e ottenere un passaggio in tutta sicurezza  
Tel. +39 02 4322 www.shareway.it

## Protótipos de Serviços – Simulação



## Protótipos de Serviços – Manchetes de Jornais



## Protótipos de Serviços - Experiência



# Protótipos de Aplicativos

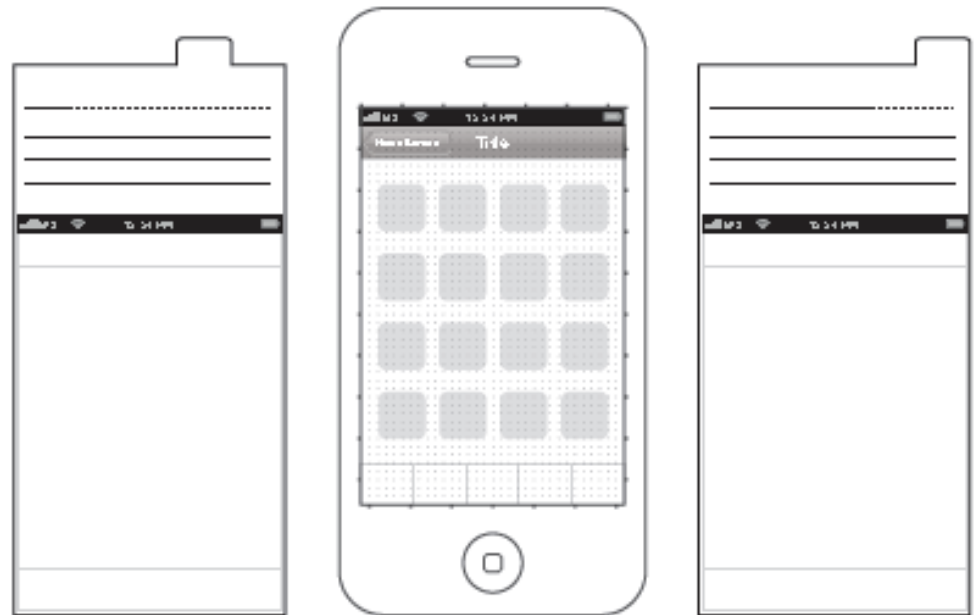

[http://66.media.tumblr.com/da3d8a74f69c6f1dbafbe6f3e1ad0fd5/tumblr\\_n6c9uwgn471qzft56o1\\_250.gif](http://66.media.tumblr.com/da3d8a74f69c6f1dbafbe6f3e1ad0fd5/tumblr_n6c9uwgn471qzft56o1_250.gif)

---

# Teste do protótipo



---

## Teste do protótipo

- Deixe os usuários interagirem com os protótipos
- Observe a experiência
- Conecte-se com os usuários
- Não se apaixone pelas ideias!

**Empatía**



# Feedback do protótipo



O que funcionou



Ideias ...

O que pode ser melhorado...



Perguntas ...



# Elaboração protótipo produto



Elaboração  
Protótipo  
Serviço



# Elaboração protótipo aplicativo

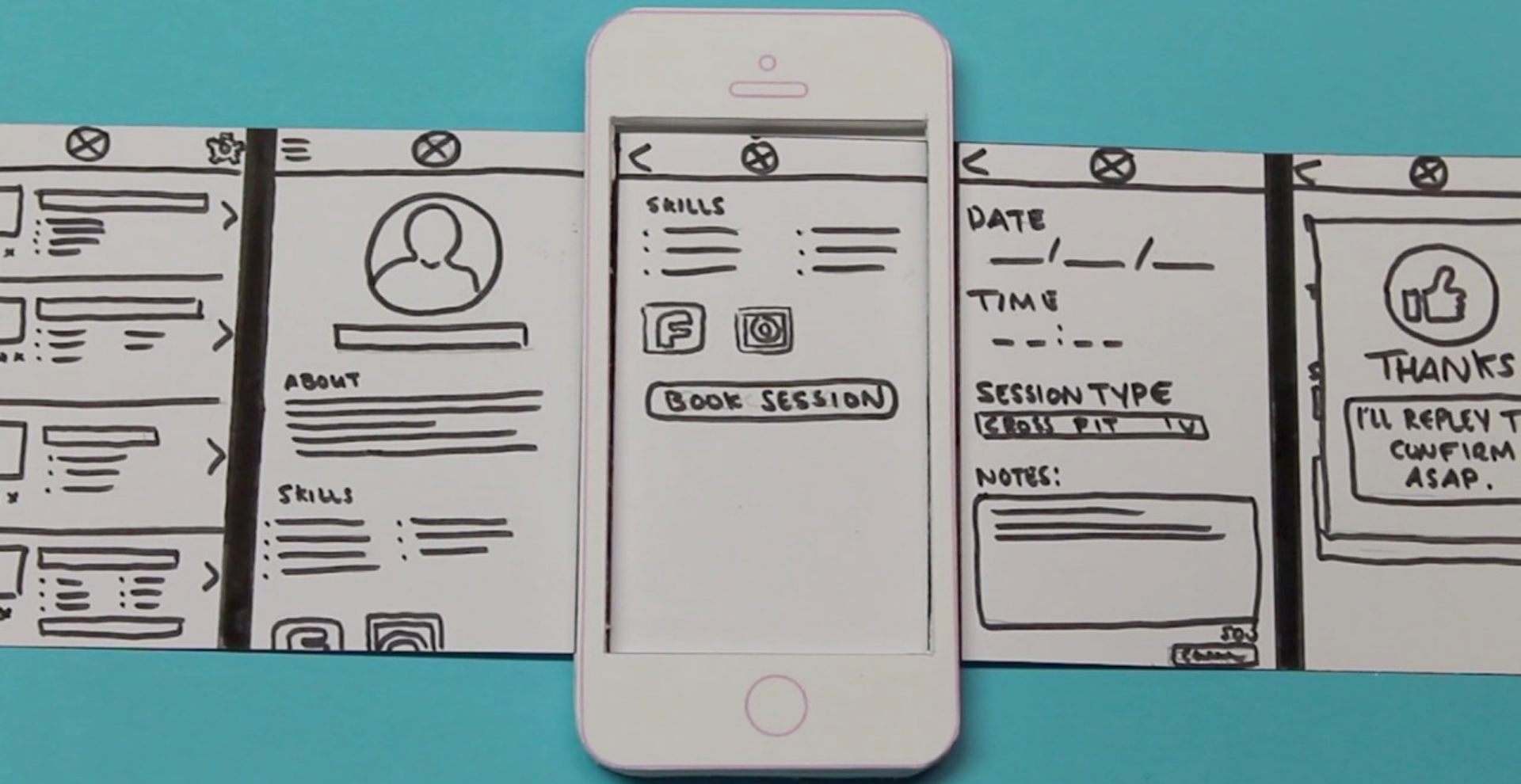

---

## Apresentação dos resultados



# DESIGN THINKING

Obrigado!