

# Regeneração no processo kraft (continuação)

## - recuperação de inorgânicos e produção de energia

Ref. básica para estudo: **Capítulos 12 e 13: Ek M, Gellerstedt G, Henriksson G. *Pulping Chemistry and Technology* (Volume 2). Berlin, Walter de Gruyter, 2009**

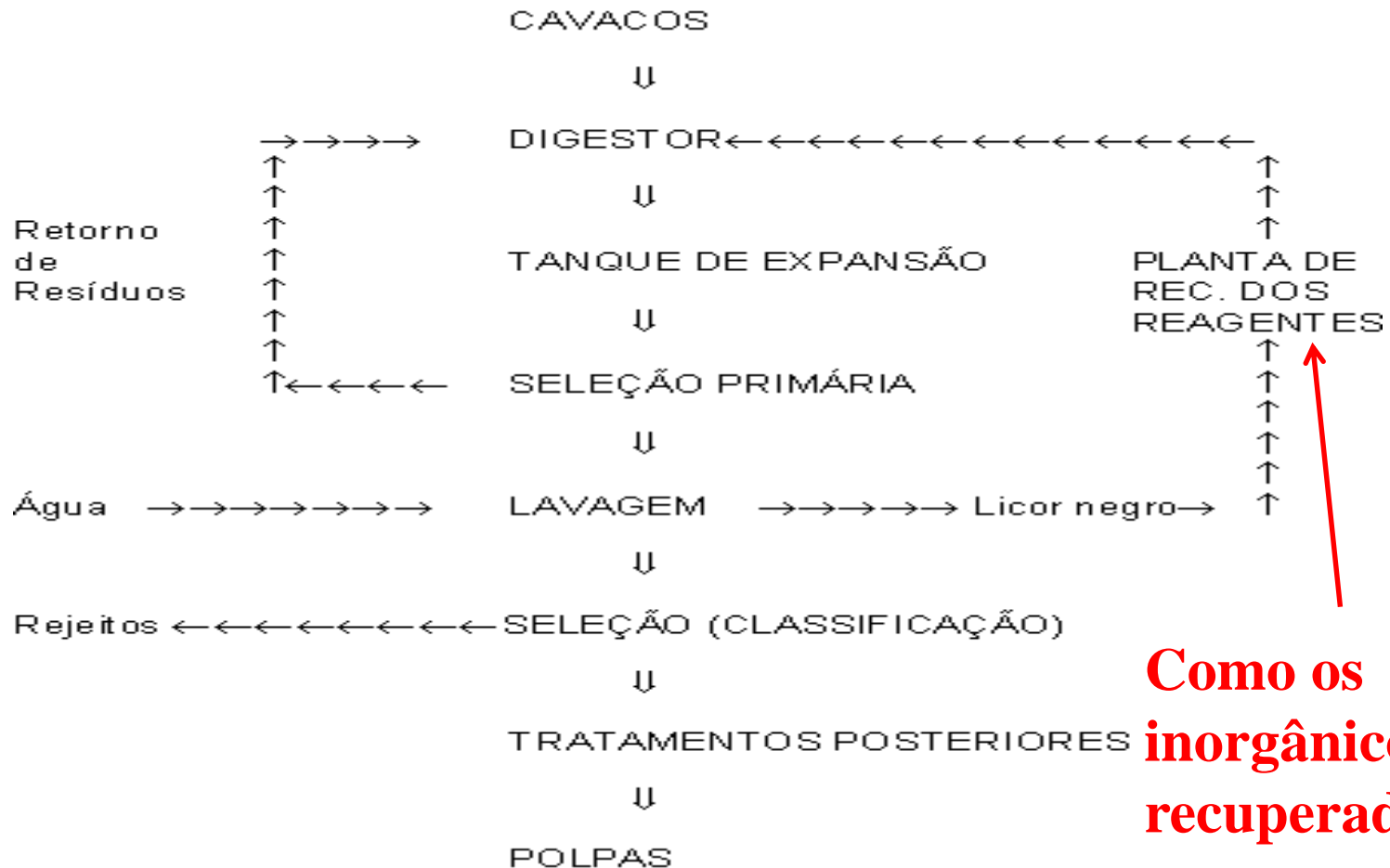

**Como os inorgânicos são recuperados?**

# A planta de recuperação no processo kraft

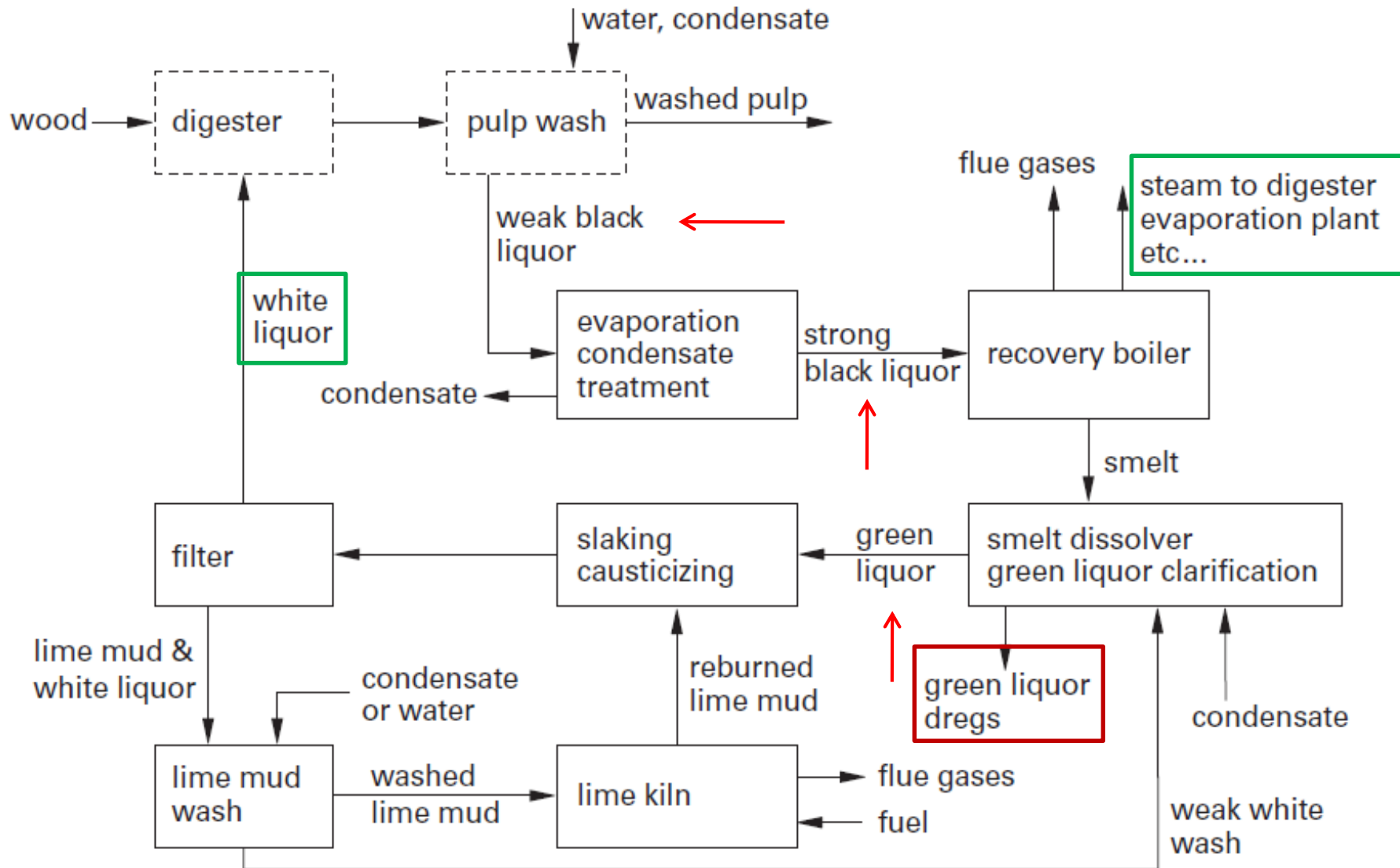

# Evaporadores usados para concentrar o licor negro

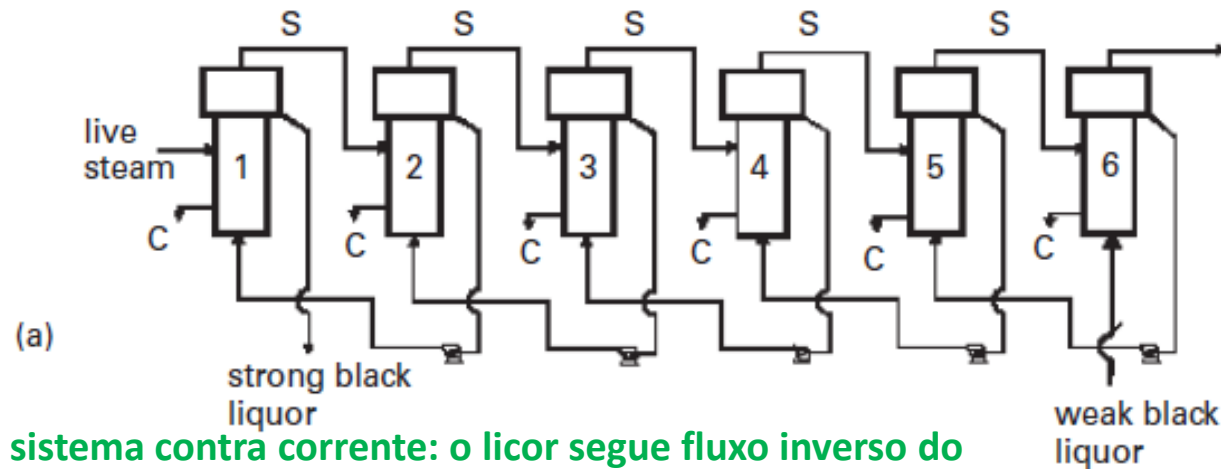

(a) sistema contra corrente: o licor segue fluxo inverso do fluxo de entrada de vapor

Licor negro não concentrado: 15-20% de sólidos (ainda não pode ser queimado, pois há excesso de água)

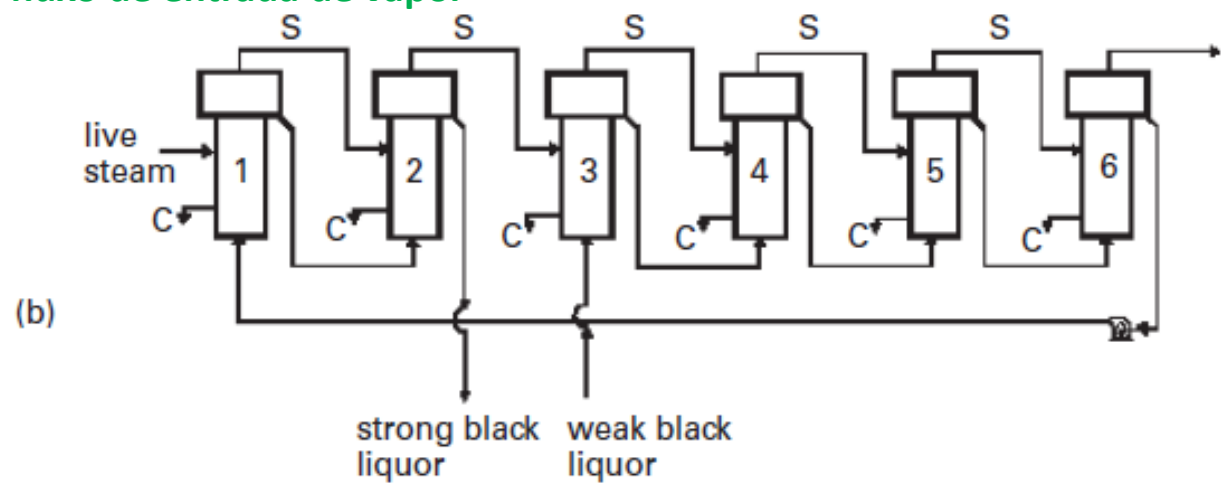

Licor negro concentrado: 70-80% de sólidos

Figure 12.3. Schematic diagram of a counter-current (a), and a mixed co- and counter-current (b), plant respectively. (S is steam and C is condensate).

# Visão detalhada de um tipo de evaporador

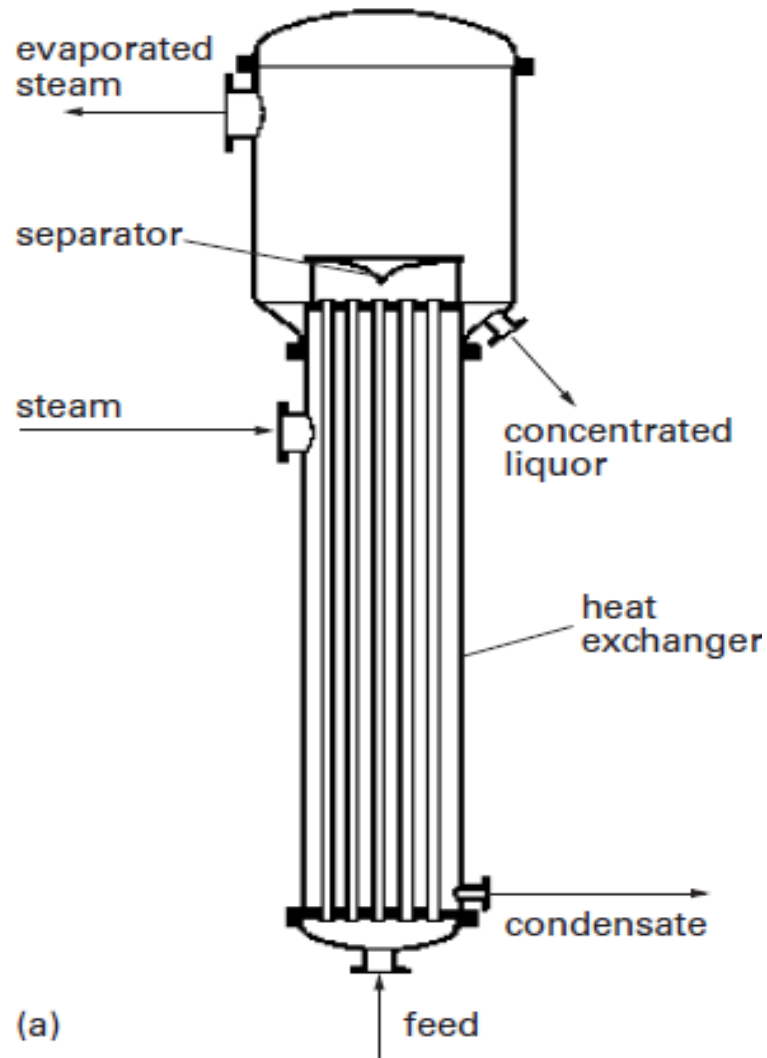

Figure 12.4. Diagram of a Kestner apparatus (A) :

# Visão detalhada de um tipo de evaporador

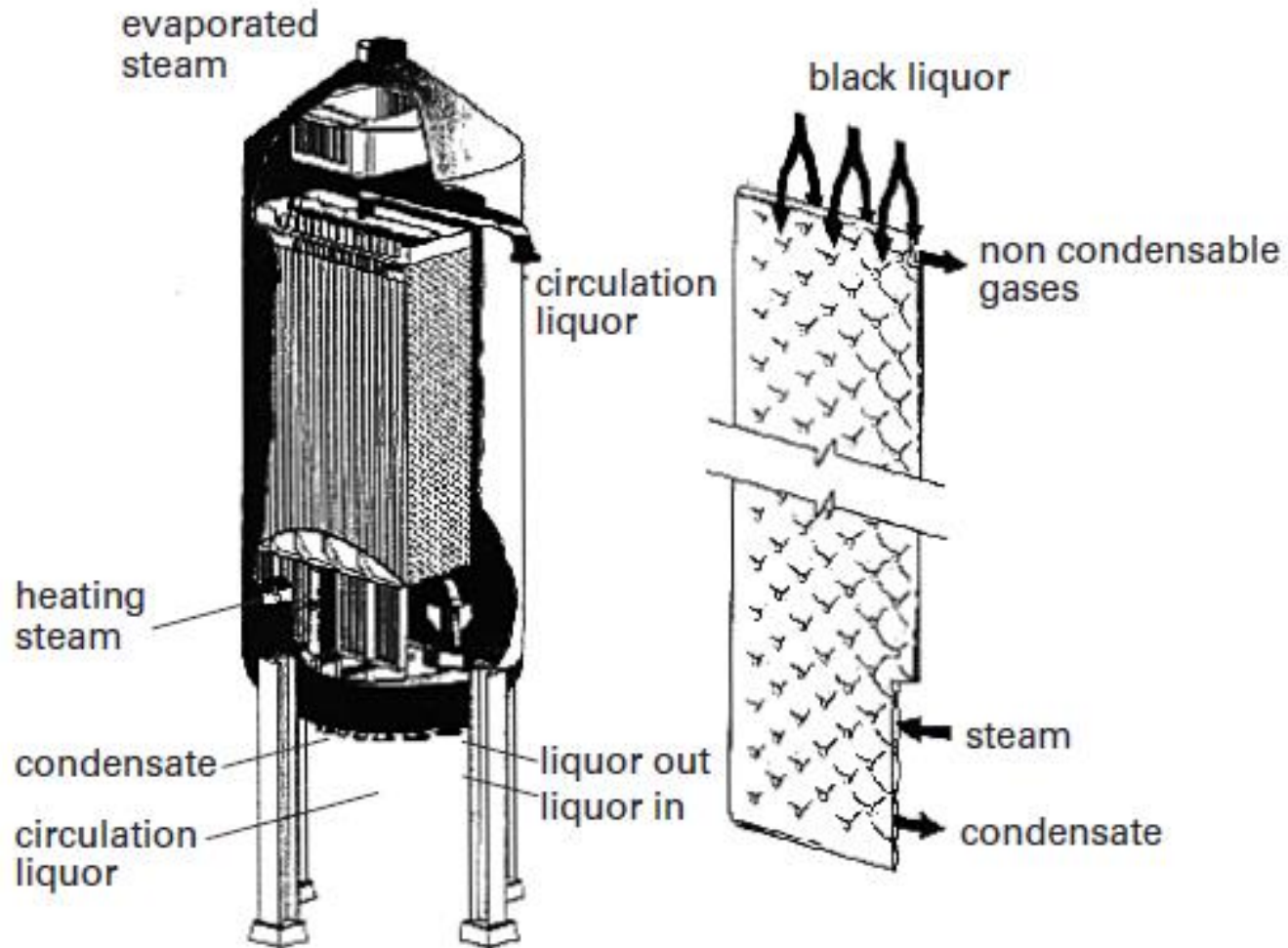
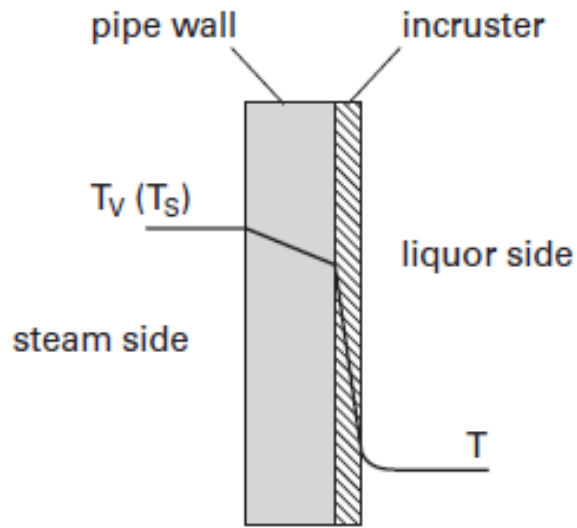

Figure 12.9. Example of an evaporator having plates as the heat exchanger device.



## Problemas de incrustação em evaporadores de licor negro

Figure 12.13. Schematic diagram of the temperature profile of a pipe with scales.

Table 12.3. Different types of scales on the liquor side of the tubes.

### A. Scales formed from insoluble material in the black liquor

- 1) Organic material: fibers etc.
- 2) Inorganic material: rust flakes, sand, etc.

### B. Precipitation of dissolved material in the black liquor

- 1) Organic material
  - i Tall oil soap (at dry contents above 25–30 %)
  - ii Lignin (ph < 11)
- 2) Inorganic material
  - i Calcium carbonate (at temperatures above 120 °C)
  - ii Burkite, a double salt of sodium sulfate and carbonate (dry contents above 50 %)
  - iii Sodium-silicon-aluminum scales (high contents of silicon and/or aluminum)

# Queima do licor concentrado

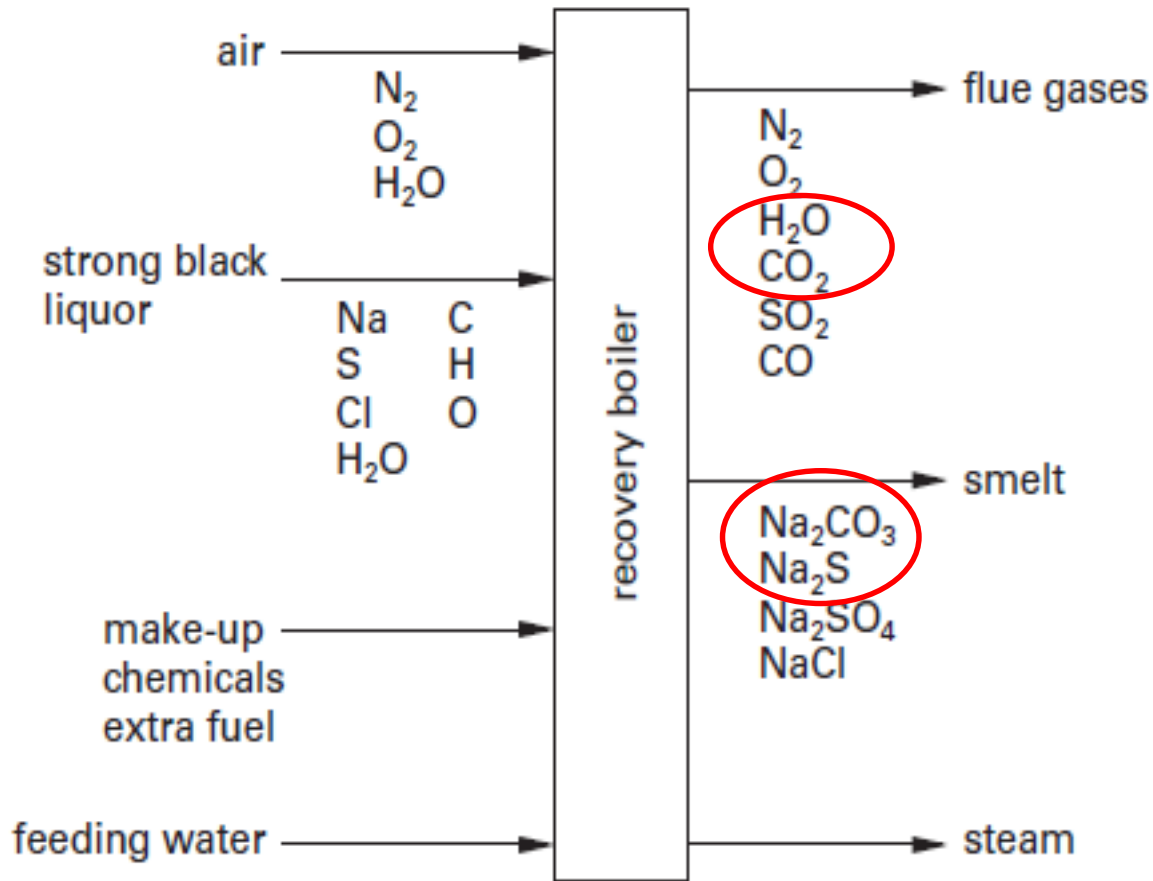

Figure 12.15. Schematic illustration of the chemical processes that take place when black liquor is combusted.

Esquema de um forno de recuperação (queima do licor negro)

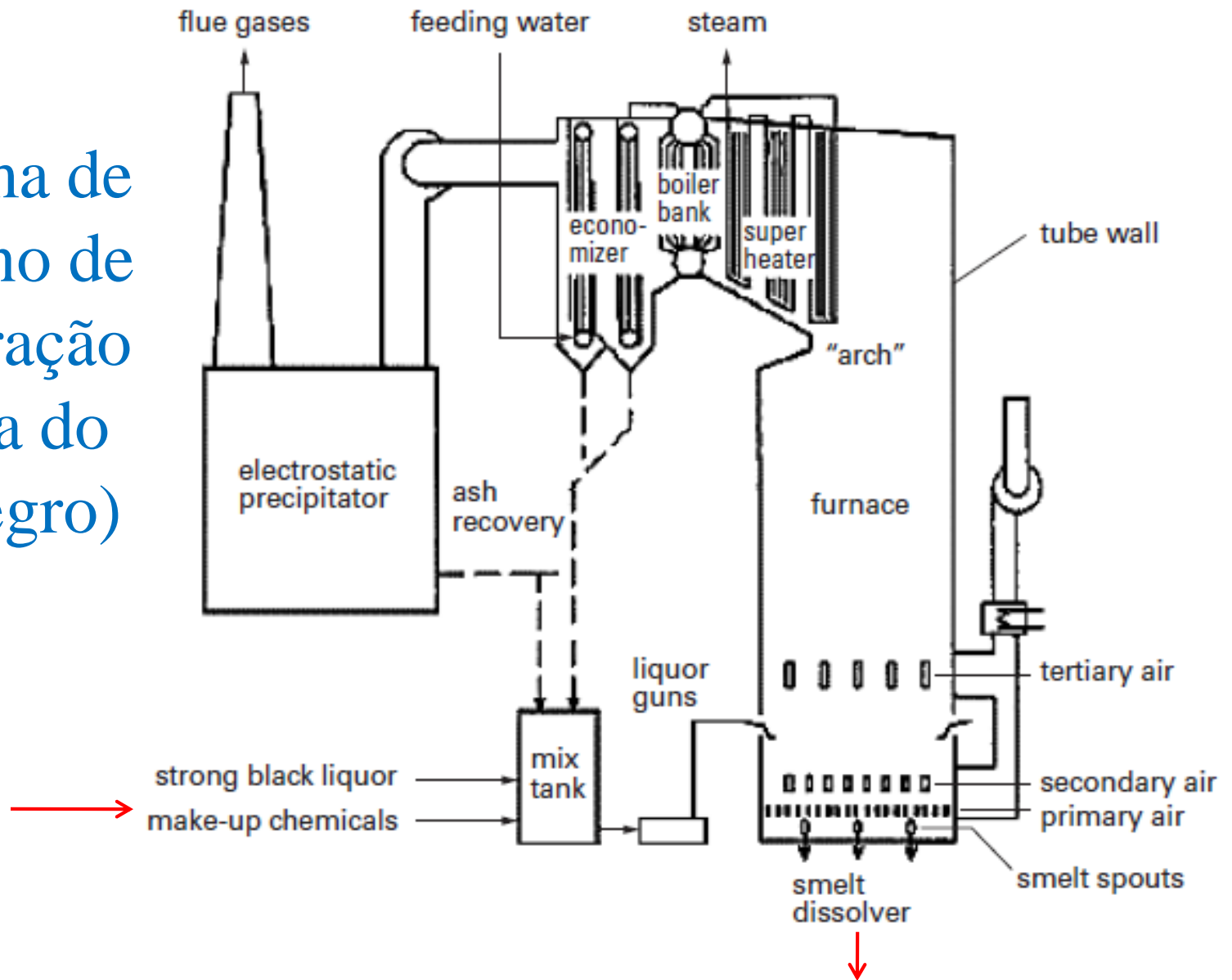
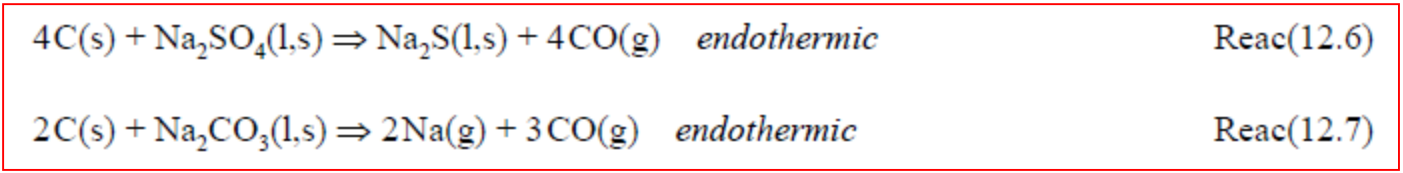
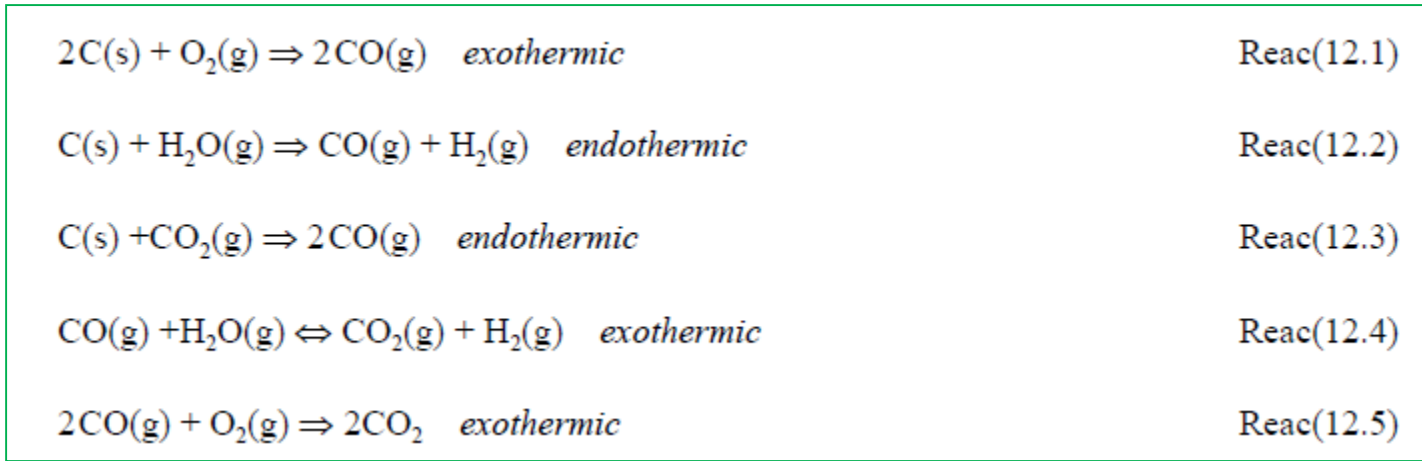

Figure 12.16. A schematic diagram of the recovery boiler.



# Reações que ocorrem durante a queima do licor negro



## Ciclo do S

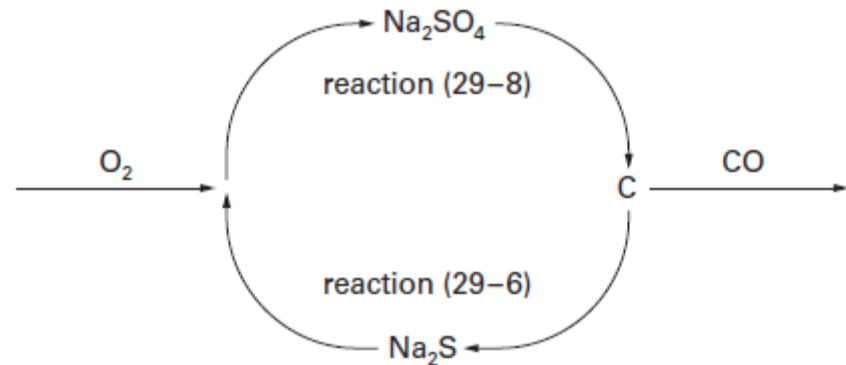
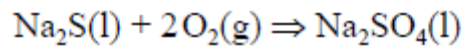
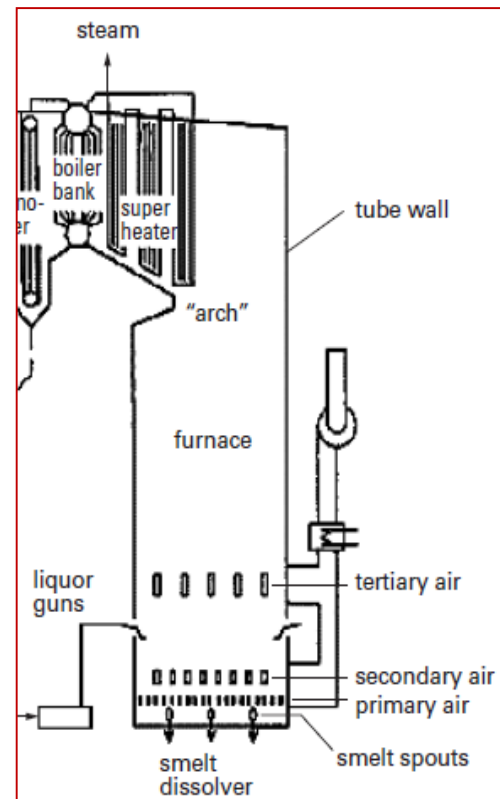
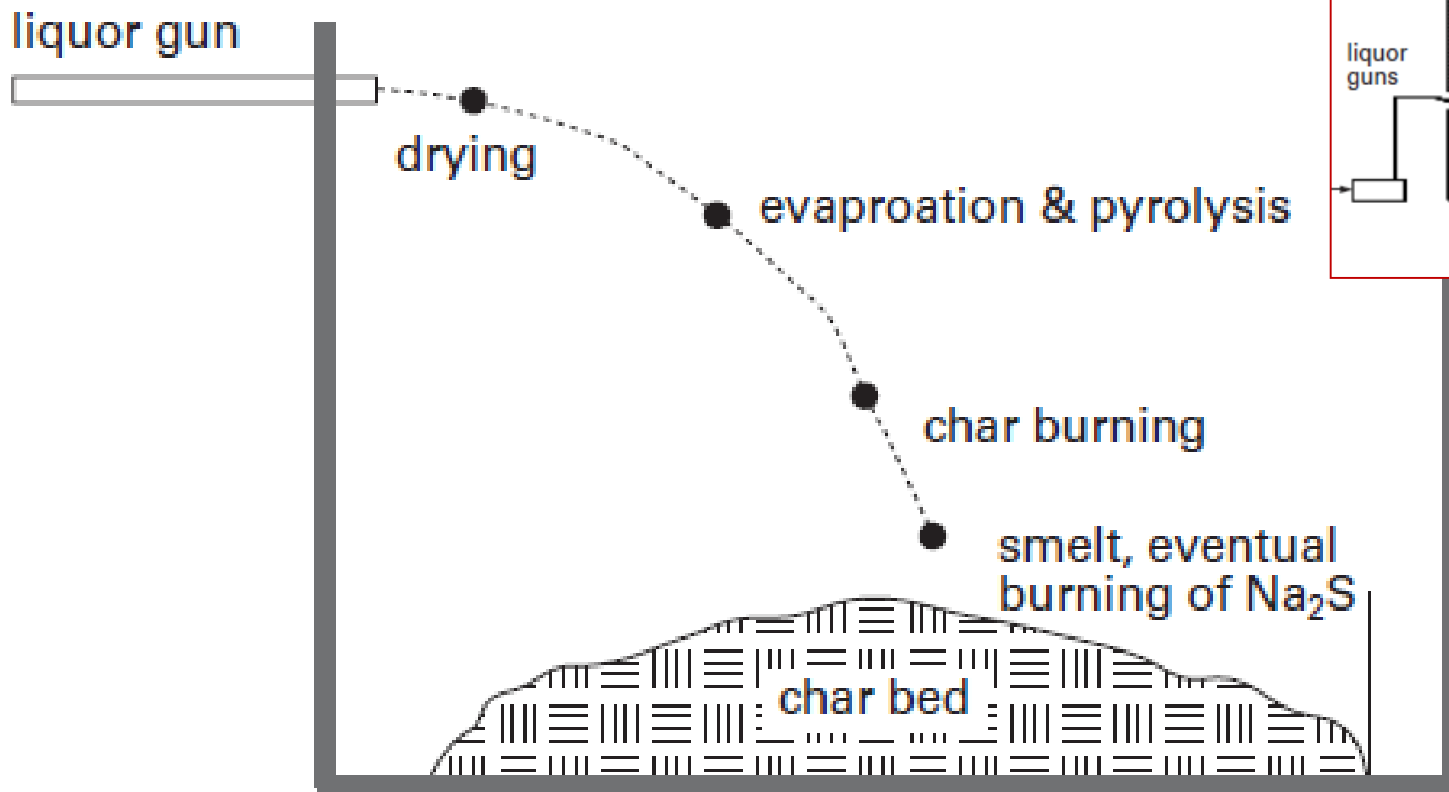

Figure 12.20. The sulfate/sulfide cycle.

## O que ocorre com uma gota de licor dentro do forno de recuperação



# Visão aproximado da zona de queima na parte inferior do forno de recuperação

<https://youtu.be/zz26bPtahUY>

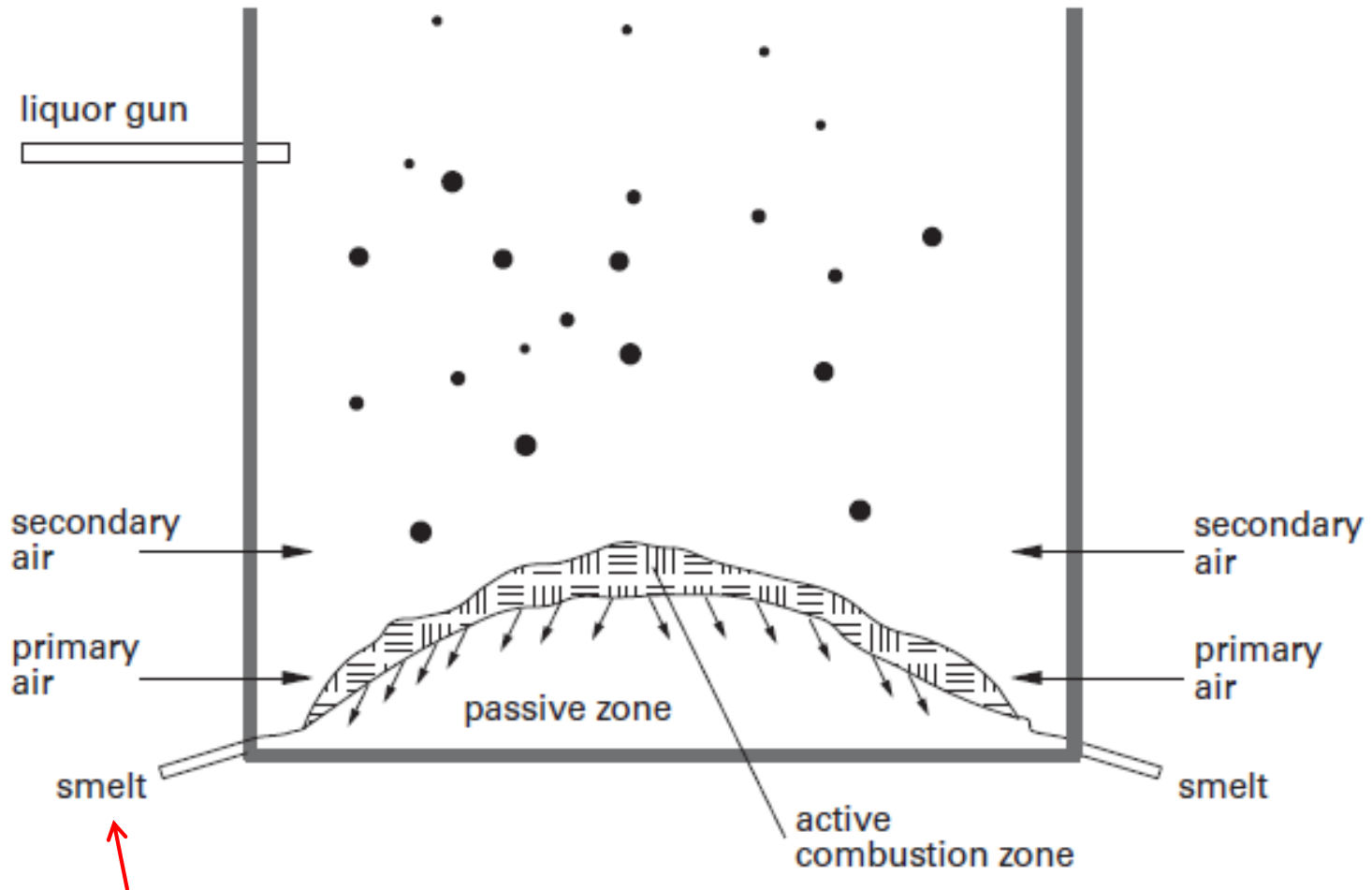

Figure 12.21. A schematic figure of the lower part of the furnace.

Thermal image >>>> <https://www.youtube.com/watch?v=Ti6M2pgIFZI>

# Sumário das reações no interior do forno de recuperação

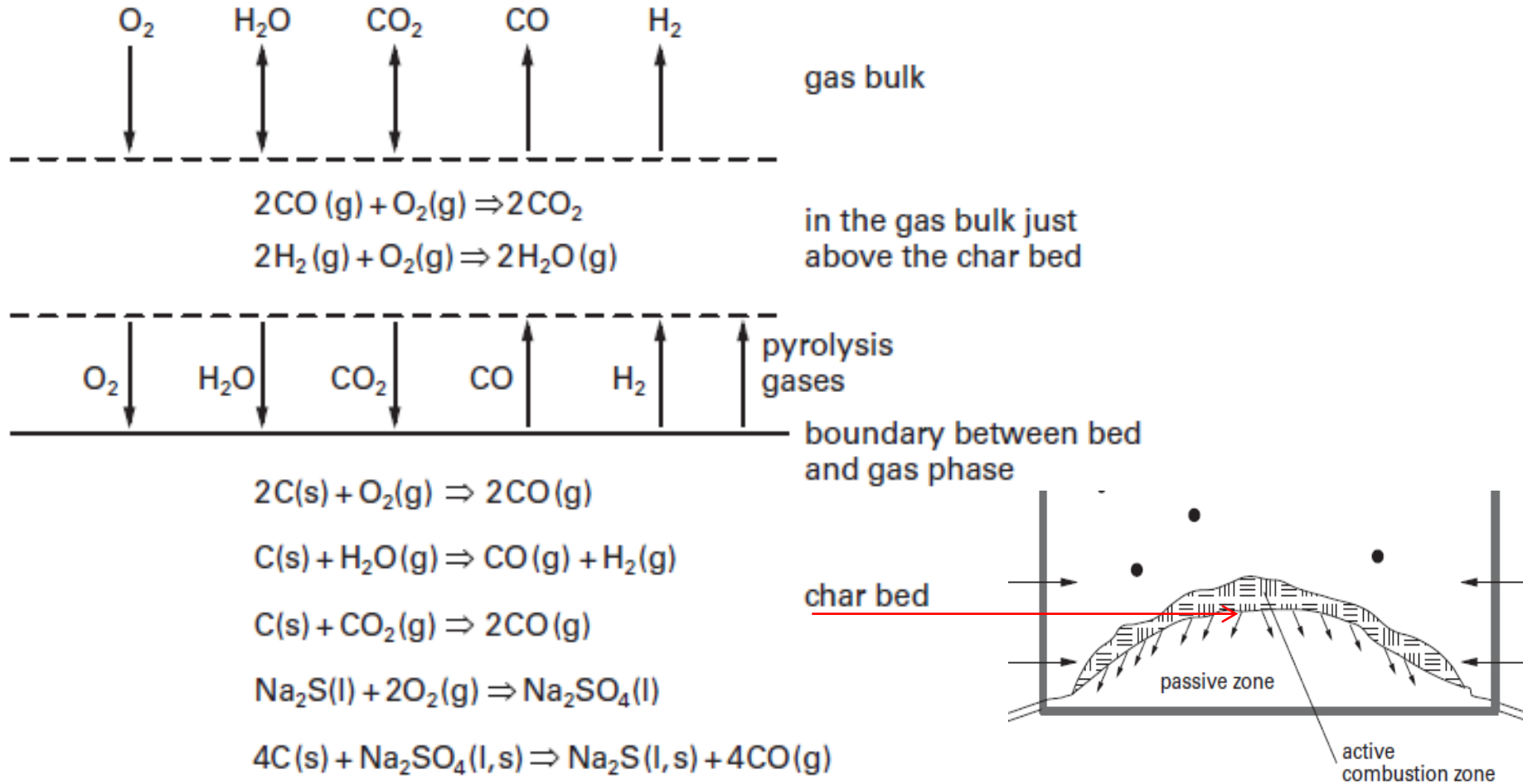
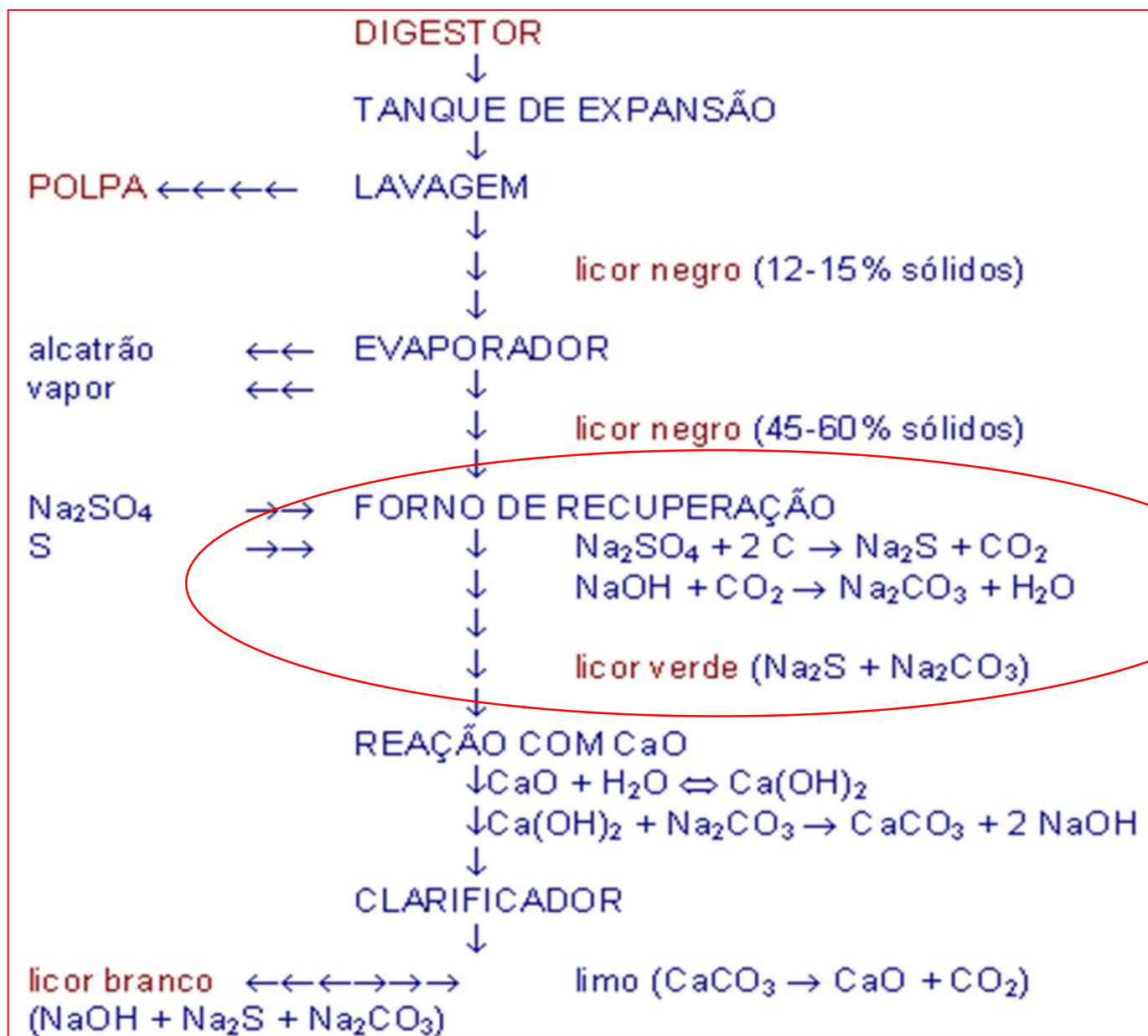

Figure 12.22. Summary of the most important reactions in the char bed, and mass transfer between the bed and the gas bulk.



# Preparação do licor branco (conversão do licor verde em branco)

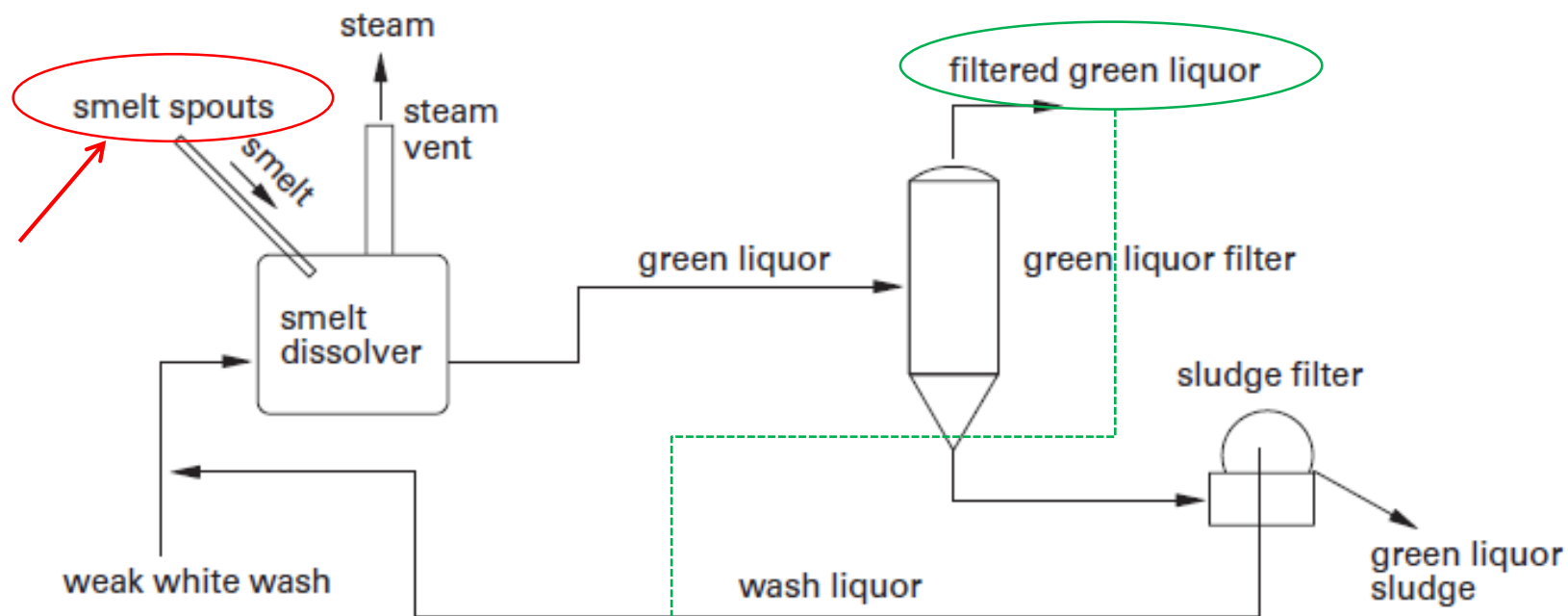

Figure 13.2. Schematic diagram of the green liquor system.

Table 13.2. Approximate concentrations of the main salts in „normal“ green liquor.

Salt/ion	Na	K	Na <sub>2</sub> CO <sub>3</sub>	Na <sub>2</sub> S	NaOH	Na <sub>2</sub> SO <sub>4</sub>	Na <sub>2</sub> S <sub>2</sub> O <sub>3</sub>	NaCl
Conc. (g/kg)	70–95	5–15	100–140	30–60	2–25	1–15	1–10	1–10

## Conversão do licor verde em licor branco

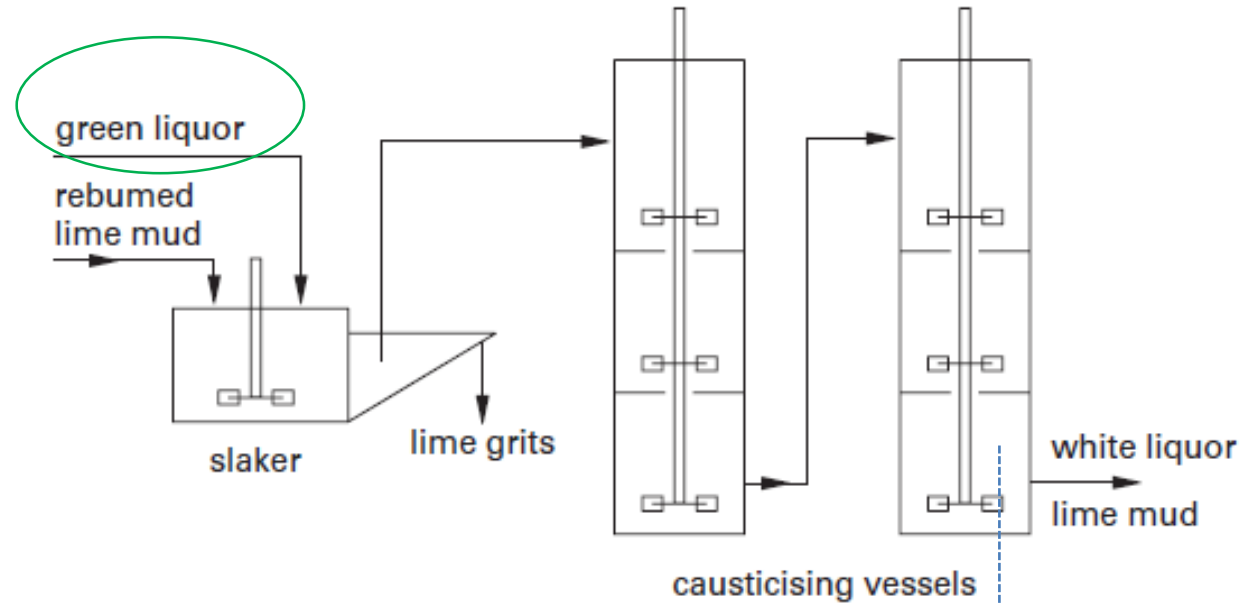
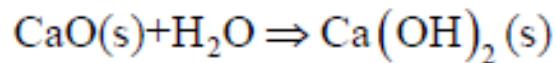
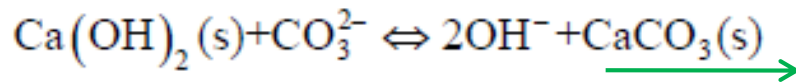

Figure 13.9. A flow sheet of the causticising department.



Reac (13.5)



Reac (13.6)

Table 13.4. Approximate composition of white liquor.

Salt/ion	Na	K	NaOH	Na <sub>2</sub> S	Na <sub>2</sub> CO <sub>3</sub>	Na <sub>2</sub> SO <sub>4</sub>	Na <sub>2</sub> S <sub>2</sub> O <sub>3</sub>	NaCl
Conc. [g/kg]	70–95	5–15	75–100	30–60	20–45	1–15	1–10	1–10

## Composição aproximada do licor branco na saída do sistema de regeneração

Componente	Concentração (g/L) - licor branco
NaOH	65,6
Na <sub>2</sub> CO <sub>3</sub>	25,6
Na <sub>2</sub> S	30,4
Na <sub>2</sub> SO <sub>4</sub>	1,6
Na <sub>2</sub> S <sub>2</sub> O <sub>3</sub>	0,1



# Regeneração de CaO (limo)

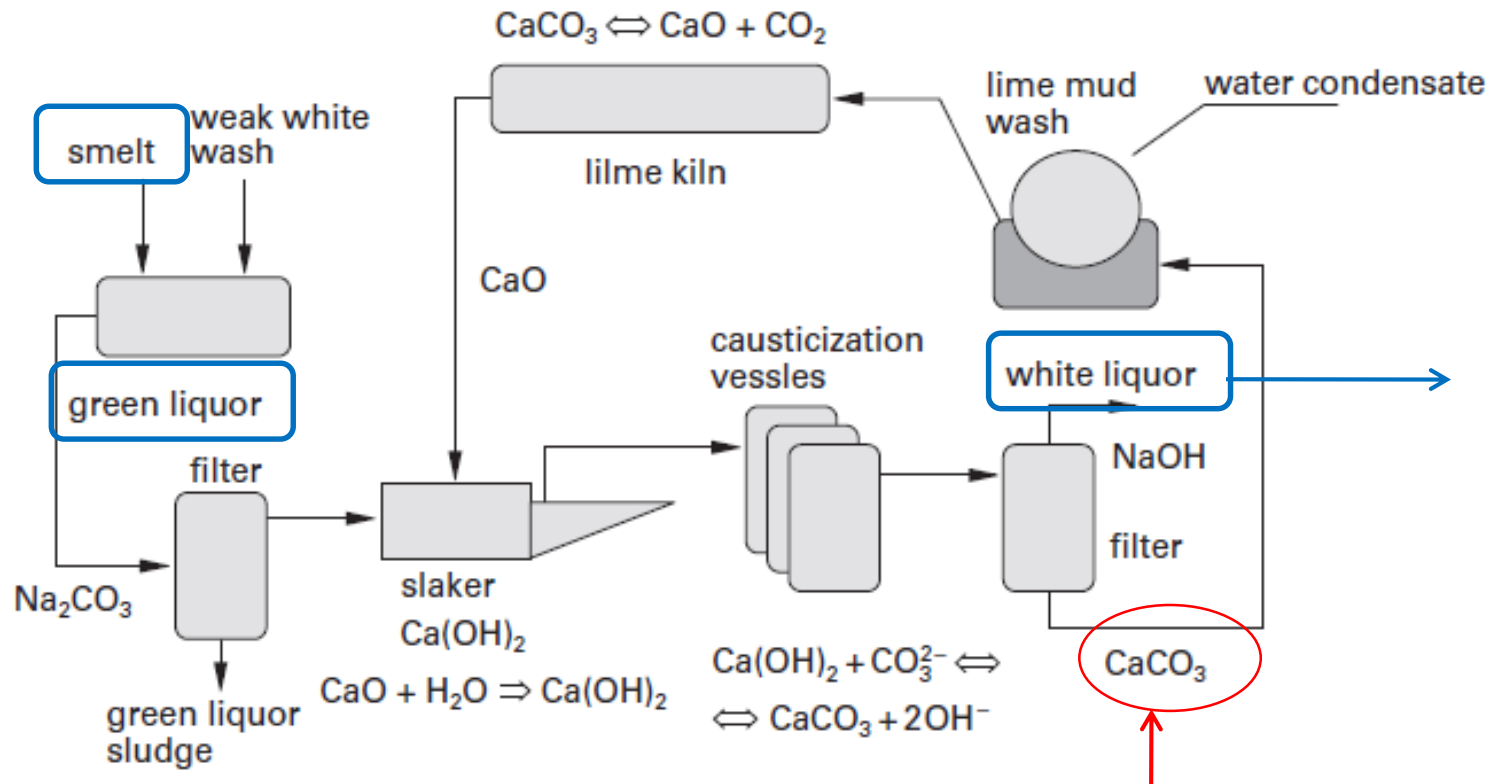

## Etapas:

1. Secagem do limo
2. Aquecimento do limo
3. Calcinação do limo



1. Evaporação do licor negro
2. Queima do licor concentrado
3. Preparação do licor branco (conversão do licor verde em branco)
4. Regeneração de CaO (limo)

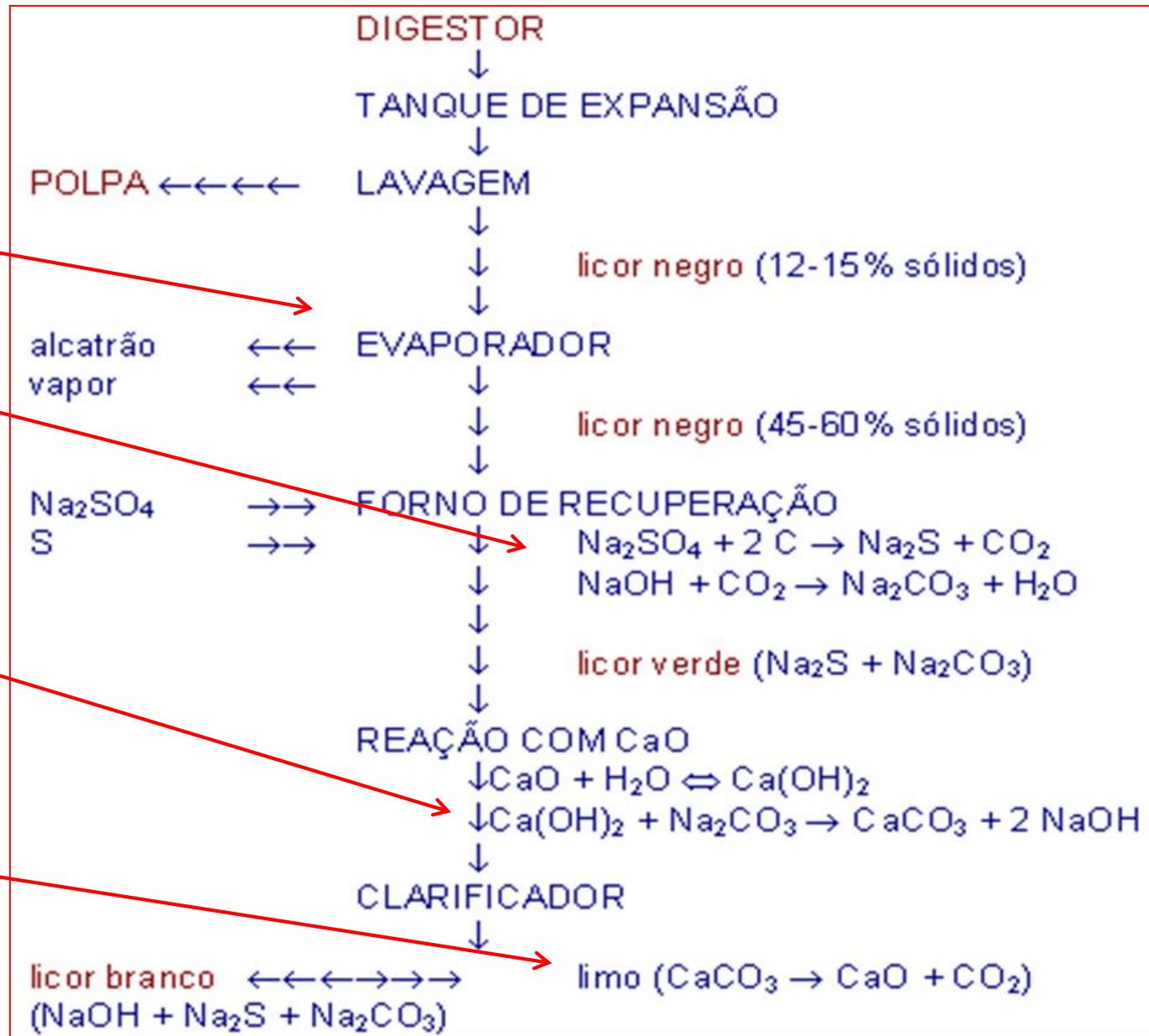

# Diagrama simplificado do processo kraft

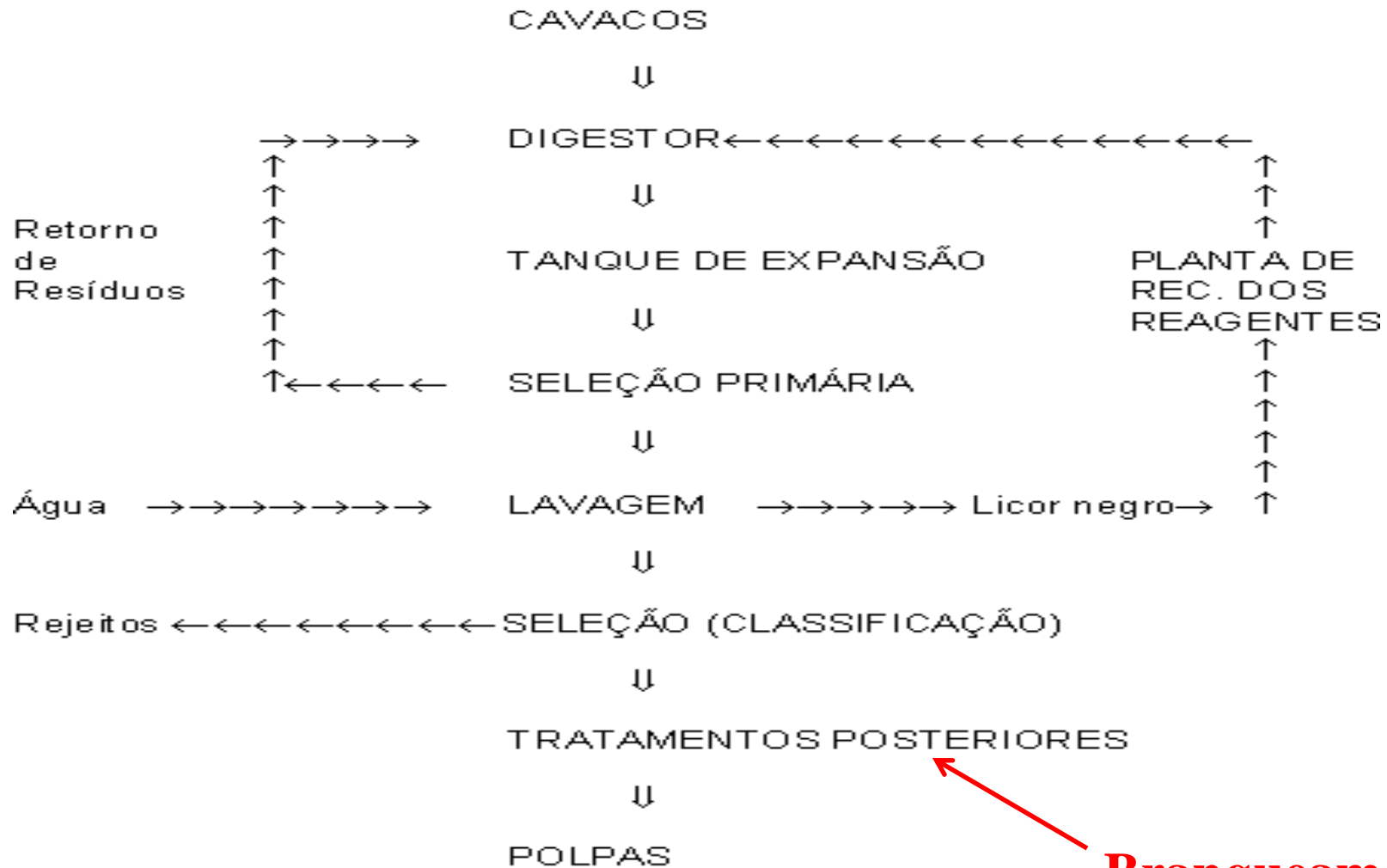

**Branqueamento**

# Branqueamento de polpas celulósicas

Dois tipos básicos:

- a) eliminação de material responsável pela cor - usado em polpas químicas
- b) transformação do material responsável pela cor em substâncias mais claras - usado em polpas mecânicas

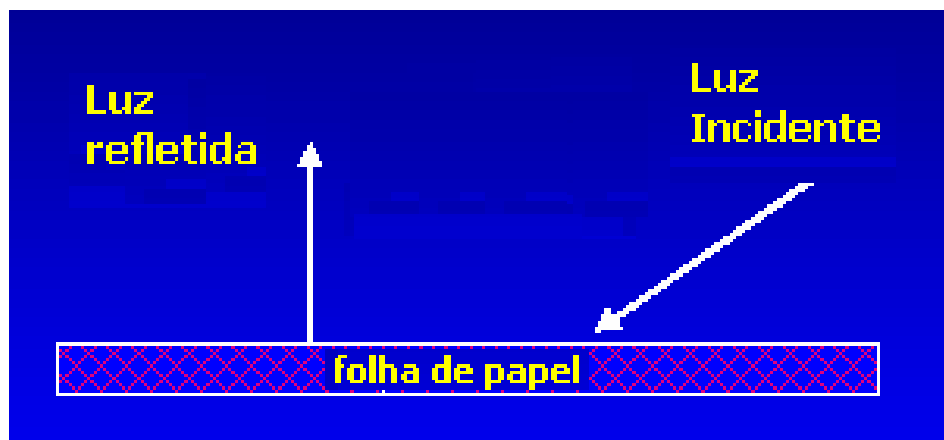

TIPO DE PAPEL	ALVURA %ISO
Impressão/cópia	80-90 ou maior que 90
Jornal	60-70
Embalagem (sacos)	25-30