



Fundamentals of --- CORROSION ---

Mechanisms, Causes,
and Preventative Methods

Philip A. Schweitzer



CRC Press
Taylor & Francis Group

Fundamentals of

CORROSION

Mechanisms, Causes,
and Preventative Methods

Fundamentals of

CORROSION

Mechanisms, Causes,
and Preventative Methods

Philip A. Schweitzer



CRC Press

Taylor & Francis Group

Boca Raton London New York

CRC Press is an imprint of the
Taylor & Francis Group, an **informa** business

CRC Press
Taylor & Francis Group
6000 Broken Sound Parkway NW, Suite 300
Boca Raton, FL 33487-2742

© 2010 by Taylor and Francis Group, LLC
CRC Press is an imprint of Taylor & Francis Group, an Informa business

No claim to original U.S. Government works

Printed in the United States of America on acid-free paper
10 9 8 7 6 5 4 3 2 1

International Standard Book Number: 978-1-4200-6770-5 (Hardback)

This book contains information obtained from authentic and highly regarded sources. Reasonable efforts have been made to publish reliable data and information, but the author and publisher cannot assume responsibility for the validity of all materials or the consequences of their use. The authors and publishers have attempted to trace the copyright holders of all material reproduced in this publication and apologize to copyright holders if permission to publish in this form has not been obtained. If any copyright material has not been acknowledged please write and let us know so we may rectify in any future reprint.

Except as permitted under U.S. Copyright Law, no part of this book may be reprinted, reproduced, transmitted, or utilized in any form by any electronic, mechanical, or other means, now known or hereafter invented, including photocopying, microfilming, and recording, or in any information storage or retrieval system, without written permission from the publishers.

For permission to photocopy or use material electronically from this work, please access www.copyright.com (<http://www.copyright.com/>) or contact the Copyright Clearance Center, Inc. (CCC), 222 Rosewood Drive, Danvers, MA 01923, 978-750-8400. CCC is a not-for-profit organization that provides licenses and registration for a variety of users. For organizations that have been granted a photocopy license by the CCC, a separate system of payment has been arranged.

Trademark Notice: Product or corporate names may be trademarks or registered trademarks, and are used only for identification and explanation without intent to infringe.

Library of Congress Cataloging-in-Publication Data

Schweitzer, Philip A.
Fundamentals of corrosion : mechanisms, causes, and preventative methods / Philip A. Schweitzer.
p. cm.
Includes bibliographical references and index.
ISBN 978-1-4200-6770-5 (hardcover : alk. paper)
1. Building materials--Corrosion. 2. Corrosion and anti-corrosives. I. Title.

TA418.74.S3847 2010
620.1'1223--dc22

2009028737

Visit the Taylor & Francis Web site at
<http://www.taylorandfrancis.com>

and the CRC Press Web site at
<http://www.crcpress.com>

Contents

List of Figures	xv
List of Tables	xix
Preface.....	xxiii
1 Introduction.....	1
1.1 Economic Losses	1
1.2 Indirect Losses.....	2
1.2.1 Shutdown	2
1.2.2 Contamination.....	2
1.2.3 Loss of Product.....	3
1.2.4 Loss of Efficiency	3
1.2.5 Environmental Damage.....	3
1.2.6 Overdesign.....	3
1.3 Conservation Losses.....	3
1.4 Nonmetallic Materials.....	4
1.5 Summary.....	4
2 Corrosion Mechanisms	5
2.1 Cell Potentials	7
2.2 Types of Local Cell Formations.....	8
2.2.1 Dissimilar Electrode Cells	9
2.2.2 Concentration Cells	9
2.2.3 Differential Temperature Cells	10
2.2.4 Oxygen Concentration Cells	11
2.2.5 Metal Ion Concentration Cells	11
2.3 Potential–pH Diagrams.....	11
2.4 Polarization	14
2.4.1 Activation Polarization	15
2.4.2 Concentration Polarization.....	17
2.5 Measuring Polarization.....	19
2.5.1 Anodic Polarization.....	21
2.6 Other Factors Affecting Corrosion	23
2.7 Corrosion Rate Measurement.....	25
2.7.1 Corrosion Rate Expressions.....	25
3 Forms of Metallic Corrosion	27
3.1 General (Uniform) Corrosion	27
3.1.1 Passive Film on Iron	28
3.1.2 Passive Film on Nickel	29
3.1.3 Passive Film on Austenitic Stainless Steel.....	29

3.1.4	Passive Film on Copper.....	29
3.1.5	Passive Film on Aluminum.....	30
3.1.6	Passive Film on Titanium.....	30
3.1.7	Passive Film on Tantalum.....	30
3.1.8	Uniform Corrosion Rates.....	30
3.1.9	Protective Measures.....	31
3.2	Intergranular Corrosion.....	32
3.2.1	Austenitic Stainless Steels.....	32
3.2.2	Ferritic Stainless Steels.....	35
3.2.3	Other Alloys.....	35
3.3	Galvanic Corrosion.....	36
3.3.3	Preventive Measures.....	38
3.4	Crevice Corrosion.....	38
3.4.1	Preventive Measures.....	40
3.5	Pitting Corrosion.....	41
3.5.1	Preventive Measures.....	43
3.6	Erosion Corrosion.....	44
3.6.1	Preventive Measures.....	45
3.7	Stress Corrosion Cracking (SCC).....	46
3.7.1	Preventive Measures.....	49
3.8	Biological Corrosion.....	50
3.8.1	Preventive Measures.....	54
3.9	Selective Leaching.....	55
3.9.1	Preventive Measures.....	57
3.10	Hydrogen Damage.....	57
3.10.1	Sources of Hydrogen.....	58
3.10.2	Types of Hydrogen Damage.....	59
3.10.2.1	Hydrogen Embrittlement.....	59
3.10.2.2	Hydrogen Blistering.....	62
3.10.2.3	Flakes, Fisheyes, and Shatter Cracks.....	63
3.10.2.4	Hydrogen Attack.....	63
3.10.3	Preventive Measures.....	65
3.10.3.1	Hydrogen Blistering.....	65
3.10.3.2	Hydrogen Embrittlement.....	66
3.10.3.3	Hydrogen Attack.....	67
3.11	Liquid Metal Attack.....	68
3.11.1	Liquid Metal Embrittlement (LME).....	69
3.11.1.1	Requirements for Embrittlement.....	69
3.11.1.2	Factors Influencing LME.....	71
3.11.1.3	Delayed Failure.....	72
3.11.1.4	Preventive Measures.....	72
3.11.2	Corrosion by Liquid Metals.....	72
3.12	Exfoliation.....	73
3.12.1	Preventive Measures.....	74
3.13	Corrosion Fatigue.....	74

3.13.1	Preventive Measures	75
3.14	Filiform Corrosion	75
3.14.1	Preventive Measures	76
	References	76
4	Atmospheric Corrosion	77
4.1	Atmospheric Types	78
4.2	Factors Affecting Atmospheric Corrosion.....	79
4.2.1	Time of Wetness	80
4.2.1.1	Adsorption Layers.....	80
4.2.1.2	Phase Layers.....	81
4.2.2	Composition of Surface Electrolyte.....	83
4.2.2.1	Oxygen.....	83
4.2.2.2	SO _x	83
4.2.2.3	NO _x	83
4.2.2.4	Chlorides	84
4.2.2.5	CO ₂	84
4.2.2.6	Concentration of Different Species.....	84
4.2.3	Temperature.....	84
4.2.4	Initial Exposure.....	85
4.2.5	Sheltering	85
4.2.6	Wind Velocity.....	86
4.2.7	Nature of Corrosion Products.....	86
4.2.8	Pollutants Present	87
4.3	Mechanisms of Atmospheric Corrosion of Metals	89
4.3.1	Damp Atmospheric Corrosion (Adsorption Layers)	90
4.3.2	Wet Atmospheric Corrosion (Phase Layers)	92
4.3.2.1	Dew	92
4.3.2.2	Rain	92
4.3.2.3	Fog.....	93
4.3.3	Deposit of Pollutants	93
4.4	Corrosion Products	94
4.5	Specific Atmospheric Corrodents.....	96
4.5.1	Sulfur-Containing Compounds.....	97
4.5.2	Nitrogen-Containing Compounds.....	99
4.5.3	Chlorine-Containing Compounds	100
4.5.4	Carbon Dioxide (CO ₂).....	101
4.5.5	Oxygen (O ₂).....	101
4.5.6	Indoor Atmospheric Compounds	101
4.6	Summary.....	101
4.7	Resistance of Specific Metals and Alloys to Atmospheric Corrosion.....	102
4.7.1	Carbon Steel.....	102
4.7.2	Weathering Steels.....	104
4.7.3	Zinc	106

4.7.4	Zinc and Zinc Alloy Coatings on Steel	109
4.7.4.1	Zinc-Aluminum Hot Dip Coatings.....	111
4.7.4.2	Zinc-Aluminum Thermally Sprayed Coatings	111
4.7.4.3	Zinc-Iron Alloy Coatings	112
4.7.4.4	Cast Zinc Alloys	112
4.7.5	Copper	112
4.7.6	Copper Alloys.....	114
4.7.6.1	Brasses.....	114
4.7.6.2	Bronzes	116
4.7.6.3	Copper-Nickel Alloys	116
4.7.7	Aluminum Alloys.....	116
4.7.7.1	Protective Measures.....	120
4.7.7.2	Applications	121
4.7.8	Stainless Steel	122
4.7.8.1	Austenitic Grades	123
4.7.8.2	Ferritic Grades	124
4.7.8.3	Martensitic Grades	124
4.7.8.4	Duplex Grades	125
4.7.9	Nickel.....	125
4.7.10	Monel Alloy	125
4.7.11	Inconel Alloy 600	125
4.7.12	Inconel Alloy 625, Incoloy Alloy 800, Incoloy Alloy 825.....	126
4.8	Atmospheric Corrosion of Nonmetals.....	126
4.8.1	Plastics.....	126
4.8.1.1	Thermoplastics	127
4.8.1.2	Thermosets	129
4.8.2	Elastomers.....	133
4.8.3	Masonry Materials.....	134
4.8.3.1	Protecting Concrete	137
4.8.3.2	Coating Selection.....	139
4.8.3.3	Polymer Concrete	140
4.8.3.4	Mortars and Grouts.....	140
4.8.4	Ceramics.....	141
4.8.4.1	Forms of Corrosion	143
4.8.4.2	Corrosion of Specific Ceramics	145
4.8.5	Wood.....	145
4.8.5.1	Plywood.....	149
4.8.5.2	Reconstituted Wood Products.....	150
4.8.5.3	Applied Exterior Wood Finishes.....	151
4.8.6	Indoor Atmospheric Corrosion.....	153
	References	154

5	Corrosion of Polymer (Plastic) Materials	157
5.1	Radiation	158
5.2	Permeation	159
5.3	Absorption	163
5.4	Thermoplasts (Thermoplastic Polymers).....	166
5.5	Thermoset Polymers	167
5.6	Environmental Cracking.....	169
6	Corrosion of Linings	171
6.1	Liquid Applied Linings.....	172
6.1.1	Design of the Vessel.....	172
6.1.2	Lining Selection	176
6.1.3	Lining Application.....	181
6.1.4	Cure of the Applied Lining	182
6.1.5	Causes of Coating Failure.....	182
6.2	Sheet Linings	183
6.2.1	Shell Design	184
6.2.2	Considerations in Liner Selection.....	185
6.2.2.1	Bonded Linings	186
6.2.2.2	Unbonded Linings	187
6.2.3	Design Considerations	188
6.2.3.1	Permeation.....	188
6.2.3.2	Absorption.....	190
6.2.4	Inspection of the Lining.....	191
6.2.5	Causes of Lining Failure	192
6.2.5.1	Liner Selection	192
6.2.5.2	Inadequate Surface Preparation	192
6.2.5.3	Thermal Stresses	192
6.2.5.4	Permeation.....	192
6.2.5.5	Absorption.....	193
6.2.5.6	Welding Flaws	193
6.2.5.7	Debonding.....	193
6.2.5.8	Operation.....	193
6.2.5.9	Environmental Stress Cracking	193
6.3	Elastomeric Linings	194
7	Corrosion of Paint	197
7.1	Mechanisms of Protection	198
7.2	Composition of Paint	200
7.2.1	Binder.....	200
7.2.2	Pigments.....	201
7.2.3	Solvents.....	202
7.2.4	Additives	204
7.2.5	Fillers (Extenders)	206
7.3	Causes of Bond and Coating Failures	206

7.3.1	Surface Preparation and Application.....	207
7.3.2	Atmospheric Effects	207
7.3.3	Types of Failures	210
7.3.3.1	Strength of Paint Film.....	210
7.3.3.2	Cohesive Failure	212
7.3.3.3	Stress and Chemical Failures	213
7.4	Types of Corrosion under Organic Coatings	213
7.4.1	Wet Adhesion	214
7.4.2	Osmosis	215
7.4.3	Blistering	215
7.4.4	Cathodic Delamination.....	216
7.4.5	Anodic Undermining.....	217
7.4.6	Filiform Corrosion	217
7.4.7	Early Rusting	218
7.4.8	Flash Rusting.....	218
7.5	Stages of Corrosion	218
7.5.1	First Stages of Corrosion	218
7.5.2	Second Stage of Corrosion.....	219
7.5.3	Third Stage of Corrosion.....	219
7.5.4	Fourth Stage of Corrosion.....	219
7.5.5	Fifth Stage of Corrosion	219
7.5.6	Final Stage of Corrosion.....	220
7.6	Surface Preparation.....	220
7.6.1	Metal Substrate Preparation.....	220
7.6.1.1	Abrasive Cleaning.....	222
7.6.1.2	Detergent Cleaning.....	222
7.6.1.3	Alkaline Cleaning.....	223
7.6.1.4	Emulsion Cleaning.....	223
7.6.1.5	Solvent Cleaning.....	223
7.6.1.6	Vapor Degreasing.....	223
7.6.1.7	Steam Cleaning.....	223
7.6.2	Metal Surface Pretreatment.....	223
7.6.2.1	Aluminum.....	224
7.6.2.2	Copper.....	224
7.6.2.3	Galvanized Steel.....	224
7.6.2.4	Steel	224
7.6.2.5	Stainless Steel.....	224
7.6.2.6	Titanium	224
7.6.2.7	Zinc and Cadmium.....	225
7.6.3	Plastic Substrate Preparation.....	225
7.6.3.1	Solvent Cleaning.....	226
7.6.3.2	Detergent Cleaning	226
7.6.3.3	Mechanical Treatments	227
7.6.3.4	Chemical Treatment.....	227
7.6.3.5	Other Treatments.....	229

7.7	Application of Coatings.....	229
7.7.1	Application Methods.....	230
7.7.1.1	Brushing	231
7.7.1.2	Rolling.....	231
7.7.1.3	Roller Coating	231
7.7.1.4	Spray Painting.....	232
7.7.1.5	Powder Coating	233
7.7.1.6	Electrodeposition of Polymers.....	234
7.7.2	Multilayer Coatings	235
7.7.3	Curing.....	238
7.7.3.1	Air-Drying.....	239
7.7.3.2	Baking	239
7.7.3.3	Force Drying	240
7.7.3.4	Reflowing.....	240
7.7.3.5	Radiation Curing.....	240
7.7.3.6	Vapor Curing.....	240
7.7.4	Inspection.....	240
7.8	Maintenance of the Coating	241
7.9	Selecting a Paint System.....	242
7.9.1	Area 1: Mild Exposure	247
7.9.2	Area 2: Temporary Protection, Normally Dry Interiors	248
7.9.3	Area 3: Normally Dry Exteriors.....	248
7.9.4	Area 4: Freshwater Exposure	250
7.9.5	Area 5: Saltwater Exposure	251
7.9.6	Area 6: Freshwater Immersion.....	251
7.9.7	Area 7: Saltwater Immersion.....	251
7.9.8	Area 8: Acidic Chemical Exposure (pH 2.0–5.0).....	251
7.9.9	Area 9: Neutral Chemical Exposure (pH 5.0–10.0).....	252
7.9.10	Area 10: Exposure to Mild Solvents	252
7.9.11	Area 11: Extreme pH Exposure.....	252
8	Corrosion of Metallic Coatings	255
8.1	Corrosion Cell.....	255
8.2	EMF Control Protection by Noble Metals	264
8.2.1	Mechanism of Control Protection	264
8.2.1.1	Copper Coatings.....	264
8.2.1.2	Gold Coatings	266
8.3	Anodic Control Protection by Noble Metals.....	267
8.3.1	Mechanisms of Control Protection.....	267
8.3.1.1	Nickel Coatings	267
8.3.1.2	Chromium Coatings	271
8.3.1.3	Tin Coatings (Tinplate).....	273
8.3.1.4	Lead Coatings	276
8.4	Cathodic Control by Sacrificial Metal Coatings	277

8.4.1	Mechanism of Control Protection	281
8.4.1.1	Zinc Coatings	281
8.4.1.2	Corrosion of Zinc Coatings	283
8.4.1.3	Zinc-5% Aluminum Hot Dip Coatings	285
8.4.1.4	Zinc-55% Aluminum Hot Dip Coatings	286
8.4.1.5	Zinc-15% Aluminum Thermal Spray	287
8.4.1.6	Zinc-Iron Alloy Coatings	288
8.4.1.7	Aluminum Coatings	289
8.4.1.8	Cadmium Coatings	289
8.4.1.9	Manganese Coatings	290
8.5	Mixed Control Protection	290
8.5.1	Phosphate Coatings	291
8.5.2	Chromate Coatings	292
8.5.3	Oxide Coatings	294
8.5.4	Anodized Coatings	295
8.6	Eclipse Molding Framework (EMF) Control Protection	296
9	Cathodic Protection	297
9.1	Background	297
9.2	Theory	298
9.2.1	Sacrificial Anodes	300
9.2.1.1	Anode Requirements	300
9.2.1.2	Anode Materials and Backfill	303
9.2.2	Impressed Current Systems	303
9.2.2.1	Current Requirements	304
9.2.2.2	Anode Materials and Backfill	304
9.2.2.3	Testing for Completeness of Protection	305
9.3	Use with Coatings	306
9.4	Economics	307
10	Corrosion Inhibitors	309
10.1	Inhibitor Evaluation	310
10.2	Classification of Inhibitors	311
10.2.1	Passivation Inhibitors	311
10.2.1.1	Mechanism of Passivation	311
10.2.2	Organic Inhibitors	315
10.2.3	Precipitation Inhibitors (Cathodic Inhibitors)	317
10.2.4	Vapor-Phase Inhibitors	317
10.3	Inhibition in Acid Solution	318
10.3.1	Physical Adsorption	319
10.3.2	Chemisorption	320
10.3.3	Interactions between Adsorbed Inhibitors	321
10.3.4	Relationships between Inhibitor Reactivity and Efficiency	321
10.4	Inhibition of Near-Neutral Solutions	321

10.5	Inhibition of Alkaline Solutions	323
10.6	Temporary Protection with Inhibitors	323
10.7	Inhibition of Localized Corrosion	324
10.8	Summary	326
	References	326
11	The Equipment Design Process	329
11.1	Understanding the Application	329
11.2	Selecting Materials of Construction	332
11.3	Controlling Corrosion by Design	335
11.3.1	Protection from Atmospheric Corrosion	335
11.3.1.1	General Design Considerations	336
11.3.1.2	Structures	337
11.3.1.3	Electrical Components	339
11.3.1.4	Control Rooms	339
11.3.1.5	Protection of Carbon Steel	340
11.3.2	Corrosion under Insulation	342
11.3.2.1	Selecting a Suitable Insulation Material	342
11.3.2.2	Design Characteristics of Insulation	344
11.3.2.3	Comparison of Jacketing	348
11.3.2.4	Design Requirements for Various Services and Systems	350
11.3.3	Industries and Systems Covered	355
11.3.3.1	Chemical Industry	356
11.3.3.2	Petroleum Refining Industry	358
11.3.3.3	Water Treatment and Supply Systems	363
11.3.3.4	Design Features	370
11.3.5	Gas Industry	371
11.3.5.1	Types of Corrosion in Underground Piping	371
11.3.5.2	Methods of Control	372
11.3.6	Pipeline Industry	372
11.3.6.1	Coatings	372
11.3.6.2	Cathodic Protection	373
11.3.6.3	Internal Corrosion	374
11.3.7	Marine Industry	374
11.3.7.1	Protection of Condensers and Saltwater Exchangers	375
11.3.7.2	Use of Aluminum in Marine Service	375
	Index	379

List of Figures

Figure 2.1	Salt concentration cell	9
Figure 2.2	Differential aeration cell.....	10
Figure 2.3	Potential–pH (Pourbaix) diagram for Fe–H ₂ O system.....	12
Figure 2.4	Polarization of iron in acid.....	15
Figure 2.5	Steps involved in hydrogen reduction reaction	16
Figure 2.6	Activation polarization curve of a hydrogen electrode.....	17
Figure 2.7	(a) Concentration polarization curve for reduction process, and (b) effect of environmental variations on concentration polarization curve.....	18
Figure 2.8	Combined curve of activation and concentration polarizations for reduction process.....	19
Figure 2.9	Anode polarization measurement apparatus	20
Figure 2.10	Anodic and cathodic polarization curve	20
Figure 2.11	Anodic polarization curve for material exhibiting active-passive behavior	21
Figure 2.12	Schematic representation of a material with active-passive behavior in different corrosive environments	22
Figure 2.13	Effects of environment and alloy content on anodic polarization behavior	23
Figure 2.14	Increased corrodent velocity can shift the cathodic polarization curve such that passive behavior can be induced	24
Figure 3.1	Effect of carbon content on carbide precipitation. Carbide precipitation forms in the areas to the right of the various carbon content curves.....	33
Figure 3.2	Formation of pit from break in mill scale	42
Figure 3.3	Loss of ductility in steel as a function of hydrogen content ..	60
Figure 3.4	Schematic of safe operating limits for steel in hydrogen	64
Figure 4.1	Schematic illustration of processes occurring in or at the aqueous layer	95

Figure 4.2	Corrosion products formed on zinc during atmospheric exposure	107
Figure 4.3	Potential-pH diagram, Al-H ₂ O; 25°C, 10 ⁻¹ M Al	117
Figure 4.4	Maximum pit depth vs. exposure time for Al Mn 1.2 in an urban atmosphere.....	118
Figure 6.1	Butt welding preferred rather than lap welding or riveted construction.....	172
Figure 6.2	Remove all weld spatter and grind smooth	173
Figure 6.3	Avoid all pockets or crevices that cannot be properly sandblasted and lined	173
Figure 6.4	All joints must be continuous solid welded and ground smooth	174
Figure 6.5	Grind all sharp edges to a minimum 1/8-in. radius	174
Figure 6.6	Typical vessel outlets	175
Figure 6.7	Stiffening members should be on the outside of the vessel.....	175
Figure 6.8	Potential galvanic action	176
Figure 7.1	Bonding situation at the interface of polymer layer and substrate	212
Figure 7.2	(a) Mechanical, (b) thermal, and (c) chemical bond failure ..	213
Figure 7.3	Blister initiation and propagation under a defective coating (cathodic delamination)	216
Figure 7.4	(a) Anodic and (b) cathodic electrodeposition of paints.....	236
Figure 8.1	Structure of the corrosion cell	256
Figure 8.2	Mechanism of the corrosion cell	257
Figure 8.3	Activation and concentration overpotentials in a typical corrosion process.....	259
Figure 8.4	Four types of corrosion controls	263
Figure 8.5	Data showing that the fractional exposed area of copper in a copper-gold system is linearly related to the corrosion potential at low exposed copper areas.....	266
Figure 8.6	Dissolution of substrate metal in coating defect.....	267
Figure 8.7	Effect of sulfur content on corrosion protection of nickel....	268

Figure 8.8 Corrosion of steel at breaks in a nickel-chromium coating when exposed to the atmosphere	272
Figure 8.9 Duplex nickel electrode deposit to prevent corrosion of steel substrate.....	272
Figure 8.10 Tin acting as both a noble and sacrificial coating.....	275
Figure 8.11 Potential reversal in tinfoot	275
Figure 8.12 Cathodic control protection	278
Figure 8.13 Schematic illustration of galvanic action of sacrificial metal coating	279
Figure 8.14 Seven-year exposure of Galfan and galvanized steel in a severe marine atmosphere.....	286
Figure 8.15 Thirteen-year exposure of Galvalume in marine and industrial atmospheres.....	288
Figure 9.1 Polarization of copper-zinc cell	299
Figure 9.2 Cathodic protection using impressed current on a local action cell	299
Figure 9.3 Plot of Sunde equation.....	302
Figure 10.1 Polarization curves that show effect of passivator concentration on the corrosion of iron.....	312
Figure 10.2 Effect of concentration of organic inhibitors on corrosion rate	316

List of Tables

Table 2.1 Standard Oxidation–Reduction Potentials 25°C, Volts vs. Hydrogen Electrode.....	8
Table 2.2 Conversion Factors from Inches per Year (ipy) to Milligrams per Square Decimeter per Day (mdd)	26
Table 3.1 Galvanic Series of Metals and Alloys in Seawater.....	37
Table 3.2 Critical Crevice Corrosion Temperatures in 10% Ferric Chloride Solution	39
Table 3.3 Pitting Resistance Equivalent Numbers.....	43
Table 3.4 Alloy–Environment Combinations Causing Stress Corrosion Cracking.....	47
Table 3.5 Combinations of Alloys and Environments for Selective Leaching	56
Table 3.6 Summary of Embrittlement Combinations	70
Table 4.1 Characteristics of Selected Gaseous Air Constituents	88
Table 4.2 Concentration of Selected Gaseous Air Constituents	88
Table 4.3 Approximate Number of Water Monolayers on Different Metals vs. Relative Humidity.....	91
Table 4.4 Classification of Hard and Soft Acids and Bases	95
Table 4.5 Atmospheric Corrosion of Various Steels in Different Atmospheric Type.....	106
Table 4.6 Wavelength Regions of the UV.....	127
Table 4.7 Abbreviations Used for Thermoplasts.....	129
Table 4.8 Allowable Temperature Ranges of Thermoplastic Polymers.	130
Table 4.9 Atmospheric Resistance of Thermoplastic Polymers	131
Table 4.10 Operating Temperature Ranges of Thermoset Polymers	132
Table 4.11 Atmospheric Resistance of Fiberglass-Reinforced Thermoset Polymers	132
Table 4.12 ASTM Designation of Elastomers	133
Table 4.13 Resistance of Elastomers to Atmospheric Pollution	135

Table 4.14 Operating Temperature Ranges of Common Elastomers.....	136
Table 4.15 Relative Low-Temperature Flexibility of the Common Elastomers	137
Table 4.16 Brittle Points of Common Elastomers.....	138
Table 4.17 Atmospheric Corrosion Resistance of Monolithic Concrete Surfacing.....	139
Table 4.18 Resistance of Polymer Concretes to Atmospheric Corrosion	141
Table 4.19 Atmospheric Corrosion Resistance of Mortars and Grouts	142
Table 4.20 Atmospheric Corrosion Resistance of Selected Glasses.....	145
Table 4.21 Atmospheric Corrosion Resistance of Selected Ceramics	146
Table 4.22 Relative Resistance to Decay (Heartwood).....	148
Table 4.23 Resistance of Wood to Decay	149
Table 4.24 Painting and Weathering Characteristics of Various Woods	152
Table 5.1 Vapor Permeation into PTFE.....	160
Table 5.2 Vapor Permeation into FEP	161
Table 5.3 Permeation of Gases into PFA.....	161
Table 5.4 Relative Gas Permeation into Fluoropolymers.....	162
Table 5.5 Water Absorption Rates of Polymers	164
Table 5.6 Absorption of Selected Liquids by FEP.....	164
Table 5.7 Absorption of Liquids by PFA	165
Table 6.1 Fluoropolymer Sheet Linings (Fabric Backed).....	187
Table 6.2 Water Absorption Rates for Common Polymers.....	190
Table 6.3 Elastomers Used as Liners.....	195
Table 7.1 Diffusion Data for Water through Organic Films.....	199
Table 7.2 Flux of Oxygen through Representative Free Films of Paint, 100 μm Thick.....	199
Table 7.3 Characteristics of Pigments for Metal Protective Paints.....	203
Table 7.4 Characteristics of Solvent Classes	205
Table 7.5 Relationship of Bond Strength to Exposure Time in 100% Relative Humidity.....	208

Table 7.6	UV Wavelength Region Characteristics	209
Table 7.7	Tensile Properties of Typical Paint Films	211
Table 7.8	Glass Transition Temperature of Organic Films	211
Table 7.9	Summary of Surface Preparation Specifications.....	221
Table 7.10	Parameters of Sulfuric Acid-Dichromate Etch Bath	228
Table 7.11	Application Examples of Multistage Paint Coating Systems for Steel Structures.....	237
Table 7.12	Solvents That Affect Organic Resins	238
Table 7.13	Multilayer Paint Systems Requiring Commercial Blast (SSPC-SP-6) for Surface Preparation	243
Table 7.14	Multilayer Paint Systems Requiring That Surface Be Abrasive Blasted in Accordance with SSPC-SP-10 Near-White Blast	246
Table 7.15	Multilayer Paint Systems Requiring Surface to Be Clean, Dry, and Free of Loose Dirt, Oils, and Chemical Contamination	248
Table 7.16	Multilayer Paint Systems for New, Clean, Surfaces Free of Chemical Contamination.....	249
Table 7.17	Multistage Paint Systems Requiring an Abrasive Blast to the Substrate Surface	250
Table 7.18	Multilayer Paint Systems for Previously Painted Surfaces That Have Had Loose Paint and Rust Removed by Hand Cleaning	250
Table 8.1	Standard Single Potentials, E°	258
Table 8.2	Hydrogen Overpotentials of Various Metals	261
Table 8.3	Corrosion Products Formed on Various Sacrificial Metal Coatings.....	278
Table 8.4	Corrosion Potentials of Sacrificial Metals in 3% NaCl Solution.....	279
Table 8.5	Average Corrosion Losses of Sacrificial Metal Coatings for 10 Years	280
Table 8.6	Five-Year Outdoor Exposure Results of Galfan Coating	286
Table 8.7	Comparison of Cathodic Protection for Galfan and Galvanized Coatings	287
Table 10.1	Effect of Chromate Concentration, Chlorides, and Temperature on Corrosion of Mild Steel	315

Table 10.2 Inhibition Efficiency of Some Pyridinium Derivatives at the Same Molar Concentration (1×10^{-4} M) on Armco Iron in Hydrochloric and Sulfuric Acid Solutions at 12°C	320
Table 11.1 Corrosion of Carbon Steels in Various Types of Atmospheres.....	341
Table 11.2 Selection Table for a Thermal Insulation System.....	343
Table 11.3 Pipe Wall Linings	367
Table 11.4 Water Storage Tank Linings and Coatings	368
Table 11.5 Corrosion Properties of Frequently Used Materials in Water Distribution Systems.....	369

Preface

The purpose of this book is to provide engineers, designers, architects, and all those involved with the selection of construction materials some basic information concerning the causes, prevention, and control of corrosion.

Corrosion is both costly and dangerous. Billions of dollars are spent annually for the replacement of corroded structures, machinery, and components. Premature failure of bridges or structures due to corrosion can also result in human injury, loss of life, and collateral damage.

Taking all these factors into account, it becomes obvious why those persons involved with the design and/or maintenance of structures and equipment should have a basic understanding of the corrosion process.

This book explains the mechanisms and forms of corrosion; the methods of attack on plastic materials; and the causes of failure of protective coatings, linings, and paints. Except for Chapter 4 that deals with atmospheric corrosion, the effect of specific corrodents on a specific material of construction is not covered, although ample sources for this information will be provided. In that chapter the effects of corrodents present in the atmosphere are discussed.

Information is also included to assist in the design and selection of materials of construction to avoid or keep to a minimum the effects of corrosion.

1

Introduction

There are three primary reasons for concern about and study of corrosion: safety, economics, and conservation. Premature failure of bridges or structures due to corrosion can result in human injury or even loss of life. Failure of operating equipment can have the same disastrous results.

Several years ago, the National Institute of Standards and Technology (formerly the National Bureau of Standards) estimated that the annual cost of corrosion in the United States was in the range of \$9 billion to \$90 billion. These figures were confirmed by various technical organizations, including the National Association of Corrosion Engineers.

Included in this estimate was corrosion attributed to chemical processes: to corrosion of highways and bridges from de-icing chemicals; to atmospheric corrosion of steel fences; to atmospheric corrosion of various outdoor structures such as buildings, bridges, towers, automobiles, and ships; and innumerable other applications exposed to the atmospheric environment. It has been further estimated that the cost of protection against atmospheric corrosion is approximately 50% of the total cost of all corrosion protection methods.

These concerns and studies have been responsible for the development of new alloys and many nonmetallic materials of construction, specifically a wide range of plastic materials of the thermoset and thermoplastic varieties, as well as the development of a wide variety of coatings and linings.

When selecting a material of construction for a particular application, that material must have certain physical, mechanical, and corrosion-resistant properties. In the selection process, cost is also an important consideration. Although many alloys may be available to meet the criteria of the application, the cost of these alloys may be prohibitive. As a result, many coating and lining materials have been developed that can be applied to less expensive materials of construction to supply the necessary corrosion protection.

1.1 Economic Losses

Economic losses can be divided into direct and indirect losses. Direct losses are those losses associated with the direct replacement of corroded equipment, components, and structures. Also included are those costs, both of

labor and material, to maintain equipment and structures to prevent corrosion from taking place or to control the rate of corrosion. Falling into this category are such items as painting, application of protective coatings or linings, operating costs for cathodically protected pipelines and structures, and routine inspections or testing of equipment by online corrosion monitoring instruments.

Economic losses are experienced industrially and domestically. Illustrative of domestic losses are replacement of home hot water heaters, rusting of automobile bodies and parts (e.g., mufflers), and failure of domestic water pipes and other miscellaneous items.

Other examples of direct losses include the additional costs incurred by the use of corrosion-resistant metals or alloys instead of less-expensive carbon steel (when carbon steel has adequate mechanical properties but insufficient corrosion resistance), by the application of corrosion-resistant coatings to carbon steel, or by the addition of corrosion inhibitors to water.

1.2 Indirect Losses

Although the causes of indirect losses can be listed, it would be extremely difficult — if not impossible — to place an actual cost on these losses. However, it would be safe to assume that these costs would be some multiple of the direct losses. Typical of these indirect losses are the following examples.

1.2.1 Shutdown

Unplanned shutdowns because of the failure of equipment resulting from corrosion lead to loss of production and consequently loss of profit. Although the actual cost of maintenance work may be minimal, the value of the lost production can be considerable. If this type of occurrence is frequent, the cost is usually added to the cost of the product.

1.2.2 Contamination

During the corrosion of a metal, the fluid being transported, stored, processed, or packaged in a metallic component can pick up metallic salts. This metallic pick-up can be detrimental to the product; with soap products a shortened shelf life, with dyes a color alteration, and in some cases of intermediate products the inability to carry out succeeding process steps. For many years, lead pipes were used to transport water until it was determined that the lead pick-up in the water caused lead poisoning in humans.

1.2.3 Loss of Product

Many times, corrosion is so severe that leakage will develop that permits loss of product. If this leakage occurs in a pipeline, it may go undetected for an extended period, during which time there is a continuous loss of product. If the leaking material itself is a corrosive material, it will attack its surroundings, thus causing additional loss. There have also been cases where leakage from underground tanks, such as gasoline, has contaminated the soil and even in some cases made the water in wells unsuitable for use.

1.2.4 Loss of Efficiency

Corrosion in a piping system can result in the buildup of a scale. This scale can cause a reduction in heat transfer as well as an increase in the power required to pump the fluid through the system. The efficient operation of other mechanical equipment can also be reduced by corrosion. This reduction in efficiency can cause an increase in operating costs as well as result in increased fuel consumption, lubricant loss, and reduced work output.

1.2.5 Environmental Damage

Corrosion of equipment used to control atmospheric pollution resulting from processing operations can result in a decrease in efficiency. Such a decrease permits pollutants from the manufacturing operation to enter the atmosphere.

1.2.6 Overdesign

In many instances when the corrosive effect of the system is known, additional thicknesses of vessel shells will be provided for in the design. This is known as corrosion allowance. Because this thickness is in addition to that required for the design conditions, an extra cost is involved. In some instances, the actual corrosive effect is not known and consequently, for safety reasons, a much thicker shell results.

1.3 Conservation Losses

Conservation losses apply primarily to the loss of raw material metallic resources through wastage resulting from corrosion. Also included in this wastage is the additional loss of energy and water reserves resulting from the manufacturing and fabrication of the metallic components. Additional human energy and resources are also consumed in the replacement and redesign of corroded equipment and components.

1.4 Nonmetallic Materials

Metallic materials do not stand alone in their susceptibility to corrosion. Other materials such as plastics, concrete, paint, coatings, and linings are also subject to corrosion. In the case of paints, coatings, and linings, failure may result from the corrosion of the substrate material due to improper application or the physical properties of the protective material.

In any case, corrosion is at the root of the failure.

1.5 Summary

When all the above factors are considered, it becomes obvious why the potential problem of corrosion should be considered during the early design stage of any project and why it is necessary to constantly monitor the integrity of structures, bridges, machinery, and equipment to prevent premature failure.

To cope with the potential problems of corrosion, it is necessary to understand:

1. Mechanisms of corrosion
2. Forms of metallic corrosion
3. Corrosive attack on nonmetallic materials
4. Corrosion-resistance properties of various materials
5. Proper fabrication and installation techniques
6. Methods to prevent or control corrosion
7. Corrosion testing techniques
8. Corrosion monitoring techniques

It is the intention of this book to deal with items 1, 2, 3, and 6. Ample references for additional reading are provided to cover the remaining items. The subject matter covered in the book includes the basics to the understanding of corrosion and how to eliminate and/or control it.

2

Corrosion Mechanisms

Most commonly used metals are unstable in the atmosphere. These unstable metals are produced by reducing ores artificially, and therefore they tend to return to their original state or to similar metallic compounds when exposed to the atmosphere. Exceptions to this are gold and platinum, which are already in their metal state.

Corrosion by its simplest definition is the process of a metal returning to the material's thermodynamic state. For most materials, this means the formation of the oxides or sulfides from which they originally started when they were taken from the earth before being refined into useful engineering materials.

These changes are electrochemical reactions that follow the laws of thermodynamics. Understanding the interactions of materials with their environment now takes on the added dimension of chemistry and electricity. These concepts help explain why corrosion processes are time and temperature dependent. They also establish that the corrosion reactions, or rates, are affected by ion and corrodent concentrations, and explain why some reactions are reversible or controllable while others are not.

Corrosion in aqueous solutions is the most common of all corrosion processes. Water, seawater, and various process streams in industry provide an aqueous medium. Moisture in the atmosphere and water in the soil account for the aqueous corrosion in these media. In all these cases, water is seldom present in pure form. Rather, various salts and gases remain dissolved in it, and their dissociation renders the water somewhat conducting. For all practical purposes, it acts as an electrolyte. The chemical nature of this electrolyte may be acidic, alkaline, or neutral.

One of the most basic corrosion reactions involves the oxidation of a pure metal when exposed to a strong acid. A familiar case is that of pure iron coming in contact with hydrochloric acid. The resulting chemical reaction is obvious, with the solution beginning to bubble violently. The reaction can be expressed as follows:

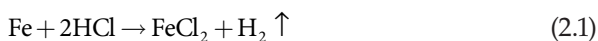

We can see the result of this reaction by the gradual disappearance of the iron and the hydrogen bubbles rising rapidly to the surface. On an electrochemical level, there is also an exchange of electrons taking place:

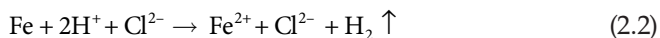

The iron has been converted to an iron ion by giving up two electrons (oxidation), which were picked up by the hydrogen ions. By gaining electrons, the hydrogen ion was reduced and formed hydrogen gas. Note that the chlorine atom does not enter into the reaction itself. The transfer of electrons is taking place on the surface of the metal. Those locations where electrons are being given up are identified as anodes. The sites where electrons are being absorbed are denoted as cathodes. A difference in electrical potential exists between these two areas and a complete electrical circuit develops. Negatively charged electrons flow in the direction of anode to cathode, and positively charged hydrogen ions in the solution move toward the cathode to complete the circuit. The faster the dissolution of the metal (rate of corrosion), the higher the current flow. The sites of the anodes and cathodes can change locations on the surface. In fact, this is exactly what happens when general or uniform corrosion takes place, with the anodic areas moving uniformly over the metal's surface.

Anodic reactions in metallic corrosion are relatively simple. The reactions are always such that the metal is oxidized to a higher valence state. During general corrosion, this will result in the formation of metallic ions of all the alloying elements. Metals that are capable of exhibiting multiple valence states may go through several stages of oxidation during the corrosion process.

It should be noted that although the actual dissolution process of the metal is taking place through anodic reaction, cathodic reaction is equally important in the overall operation. The electrons liberated by anodic reaction are consumed in the cathodic process. A corroding metal does not accumulate any charge. It therefore follows that these two partial reactions of oxidation and reduction must proceed simultaneously and at the same rate to maintain this electroneutrality. Some basic concepts of corrosion control also evolve from this simple electrochemical picture. Retarding the cathodic process can retard metal dissolution; metal dissolution can also be retarded or stopped altogether by the supply of electrons to the corroding metal from any external source. The latter forms the basis of cathodic protection.

Cathodic reactions are more difficult to predict but can be categorized into one of five different types of reduction reactions:

Hydrogen evolution

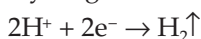

Metal ion reduction

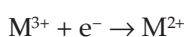

Oxygen reduction-neutral solutions

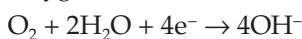

Oxygen reduction in acids

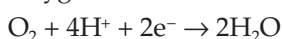

Metal deposition



2.1 Cell Potentials

Understanding electrochemical behavior and possible reactions can help in predicting the possibility and extent of corrosion. A reaction will occur only if there is a negative free energy change (ΔG). For electrochemical reactions, the free energy change is calculated from:

$$\Delta G = -nFE$$

where n is the number of electrons, F is Faraday's constant, and E is the cell potential.

Therefore, for a given reaction to take place, the cell potential is taken as the difference between the two half-cell reactions — the one at the cathode minus the one at the anode. The half-cell potential exists because of the difference in the neutral state compared to the oxidized state, such as Fe/Fe^{2+} , or at the cathode, the difference between the neutral state and the reduced state as in H^+/H_2 . These reduction–oxidation (redox) potentials are measured relative to a standard half-cell potential. The chart in Table 2.1 lists potentials relative to the H^+/H_2 , which is set at zero.

Looking at the example of iron corroding freely in acid, the cell potential is calculated as:

$$E = \text{Cathode half-cell} - \text{Anode half-cell}$$

$$E = E(\text{H}^+/\text{H}_2) - E(\text{Fe}/\text{Fe}^{2+})$$

$$E = 0 - (0.440) = +0.44$$

Because the cell potential is positive, the reaction can take place.

The larger the potential difference, the greater the driving force for the reaction. Whether corrosion does occur and at what rate depends on other factors. For corrosion to occur, there must be a current flow and a completed circuit, which is then governed by Ohm's law: $I = E/R$. The cell potential calculated here represents the peak value for the case of two independent reactions. If the resistance were infinite, the cell potential would remain as calculated but there would be no corrosion at all. If the resistance of the circuit is zero, the potentials of each half-cell would approach the other while the rate of corrosion would be infinite.

TABLE 2.1
Standard Oxidation–Reduction Potentials
25°C, Volts vs. Hydrogen Electrode

Redox Reaction	Oxidation–Reduction Potential
$\text{Au} = \text{Au}^{3+} + 3\text{e}^-$	+1.498
$\text{O}_2 + 4\text{H}^+ + 4\text{e}^- = 2\text{H}_2\text{O}$	+1.229
$\text{Pt} = \text{Pt}^{2+} + 2\text{e}^-$	+1.2
$\text{Pd} = \text{Pd}^{2+} + 2\text{e}^-$	+0.987
$\text{Ag} = \text{Ag}^+ + \text{e}^-$	+0.799
$2\text{Hg} = \text{Hg}_2^{2+} + 2\text{e}^-$	+0.788
$\text{Fe}^{3+} + \text{e}^- = \text{Fe}^{2+}$	+0.771
$\text{O}_2 + 2\text{H}_2\text{O} + 4\text{e}^- = 4\text{OH}^-$	+0.401
$\text{Cu} = \text{Cu}^{2+} + 2\text{e}^-$	+0.337
$\text{Sn}^{4+} + 2\text{e}^- = \text{Sn}^{2+}$	+0.15
$2\text{H}^+ + 2\text{e}^- = \text{H}_2$	0.0000
$\text{Pb} = \text{Pb}^{2+} + 2\text{e}^-$	-0.126
$\text{Sn} = \text{Sn}^{2+} + 2\text{e}^-$	-0.136
$\text{Ni} = \text{Ni}^{2+} + 2\text{e}^-$	-0.250
$\text{Co} = \text{Co}^{2+} + 2\text{e}^-$	-0.277
$\text{Cd} = \text{Cd}^{2+} + 2\text{e}^-$	-0.403
$\text{Fe} = \text{Fe}^{2+} + 2\text{e}^-$	-0.440
$\text{Cr} = \text{Cr}^{3+} + 3\text{e}^-$	-0.744
$\text{Zn} = \text{Zn}^{2+} + 2\text{e}^-$	-0.763
$\text{Al} = \text{Al}^{3+} + 3\text{e}^-$	-1.662
$\text{Mg} = \text{Mg}^{2+} + 2\text{e}^-$	-2.363
$\text{Na} = \text{Na}^+ + \text{e}^-$	-2.714
$\text{K} = \text{K}^+ + \text{e}^-$	-2.925

2.2 Types of Local Cell Formations

Three main types of local cell formations leading to corrosion are encountered in practice:

1. Dissimilar electrode cells
2. Concentration cells:
 - a. Salt concentration cell
 - b. Differential aeration cell
3. Differential temperature cells

2.2.1 Dissimilar Electrode Cells

Dissimilar electrode cells may be formed when two dissimilar metals are in contact or due to the heterogeneity of the same metal surface. The Daniel cell is an example of the former. In practice, a copper pipe connected to a steel pipe or a bronze propeller in contact with the steel hull of a ship provides an example of this type of corrosion cell. This is often referred to as galvanic coupling, in which the less noble metal becomes the anode. Galvanic corrosion is discussed further in Chapter 3. A cold worked metal in contact with the same metal annealed leads to a similar situation (i.e., the cold worked metal remaining anodic). On the same metal surface, such type of cell formation may result from dissimilar phases and impurities, grain boundaries, differentially strained areas, and scratches or abrasions. In a single crystal, the different crystal faces differ in their electrochemical characteristics because of the difference in their atomic orientation and, as a result, one crystal face tends to become anodic compared to the others.

2.2.2 Concentration Cells

Concentration cells are formed when the electrodes are identical but are in contact with solutions of differing composition. A *salt concentration cell* forms when one electrode is in contact with a concentrated solution and the other electrode with a dilute solution. On short-circuiting, the electrode in contact with the dilute solution will be anodic (refer to Figure 2.1). The local variation

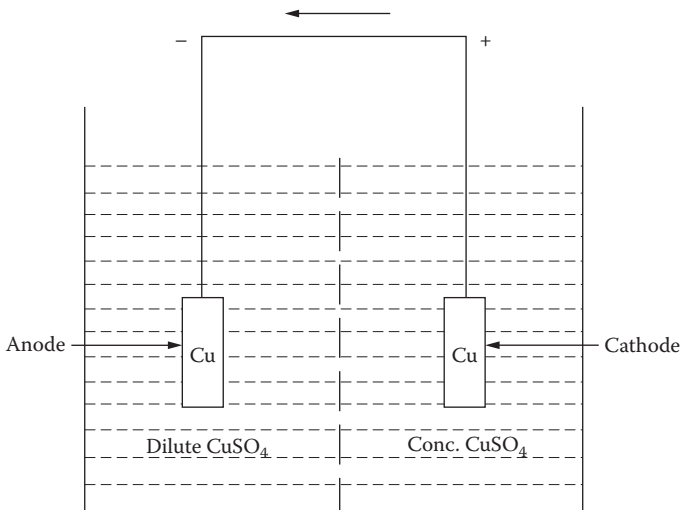

FIGURE 2.1
Salt concentration cell.

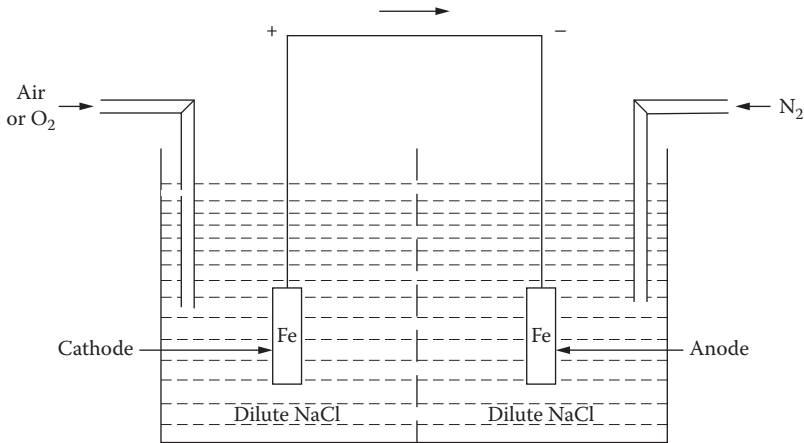

FIGURE 2.2
Differential aeration cell.

of composition of the process stream inside the pipeline in a chemical plant may lead to such a situation in practice.

A *differential aeration cell* forms when the identical electrodes are exposed to solutions of identical chemical composition that differ in oxygen content, which is illustrated in Figure 2.2. The electrode in contact with the less aerated or oxygenated solution will act as the anode.

Differential aeration cell formation is quite common in operation and is very important from the viewpoint of practical corrosion damage. A metallic bucket half filled with water tends to corrode just below the water line because of the lower oxygen concentration compared to the area just above it near the water line. Corrosion damage invariably becomes pronounced underneath a corrosion product or at crevices where oxygen availability is low. Formation of concentration cells of both kinds accounts for the initiation of pits (discussed in Chapter 3) in stainless steels and in some other metals and alloys exposed to seawater.

2.2.3 Differential Temperature Cells

Differential temperature cells are formed when electrodes of the same metal, each of which is at a different temperature, are immersed in an electrolyte of the same initial composition. Such a situation may arise in practice in components of heat exchangers, boilers, and similar heat transfer equipment. Polarity developed in an electrode varies from system to system. For a copper electrode in a copper sulfate solution, the electrode at the higher temperature is the cathode; but for lead, the situation is just the reverse. For iron immersed in dilute aerated sodium chloride solutions, the hot electrode is initially anodic to the colder metal, but the polarity may reverse with the progress of corrosion.

2.2.4 Oxygen Concentration Cells

The oxygen-reduction reaction that occurs in neutral or basic solutions, $O_2 + 2H_2O + 4e^- \rightarrow 4OH^-$, plays a significant role in many corrosion processes. It not only contributes to sustaining a cathodic reaction, but also can induce one. This occurs when substantial differences in dissolved oxygen content exist at one area on the metal surface relative to another. The natural tendency is to equal concentrations, and the means of achieving this by corrosion is to lower the oxygen concentration at the region where it is the highest. The oxygen-reduction reaction accomplishes this but the area where this occurs becomes cathodic to the lower oxygen concentration region. Because of the current flow created by this action, corrosion will occur at the anodic or low oxygen concentration site.

2.2.5 Metal Ion Concentration Cells

Metal ion concentration cells can also develop and fuel the corrosion process. This situation arises when a significant difference in metal ion concentration exists over a metal surface. The tendency is to reach equilibrium ion concentration, and in a corrosive environment this is managed by putting more metal ions into solution at the low-concentration area. This area becomes the anode, and the current flow generated by this process can result in plating out metal ions at the cathodic or high metal ion concentration region.

2.3 Potential–pH Diagrams

Potential–pH diagrams, also known as Pourbaix diagrams, are graphical representations of the stability of a metal and its corrosion products as a function of the potential and pH (acidity or alkalinity) of the aqueous solution. The potential is shown on the vertical axis and the pH on the horizontal axis. Such diagrams are constructed from calculations based on the Nernst equation and the solubility data for various metal compounds. The potential–pH diagram for an Fe–H₂O system is shown in Figure 2.3. In the diagram, the horizontal lines represent pure electron transfer reactions dependent solely on potential, but independent of pH:

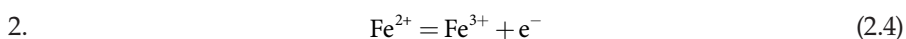
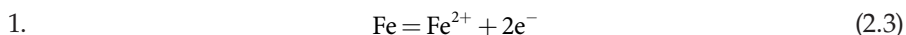

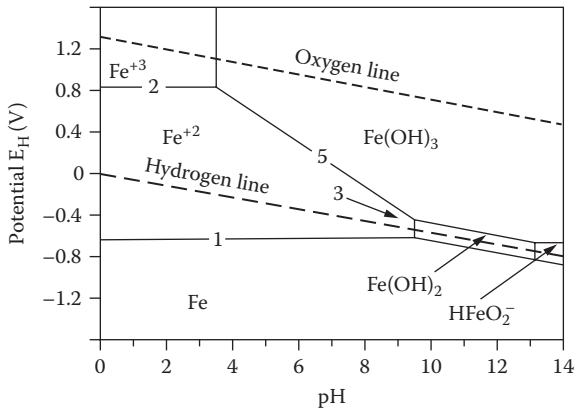
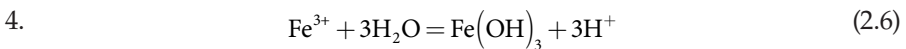
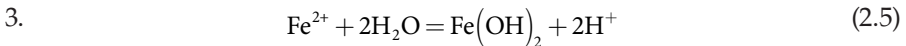

FIGURE 2.3
Potential-pH (Pourbaix) diagram for Fe-H₂O system.

These lines extend across the diagram until the pH is sufficiently high to facilitate the formation of hydroxides, represented by vertical lines, thereby reducing the concentration Fe²⁺ and Fe³⁺ ions. The boundary is often set arbitrarily at the concentration of these ions at 10⁻⁶ g-ions/liter, which is indicative of a negligible dissolution or corrosion of the metal in the medium.

The vertical lines in Figure 2.3 correspond to the reactions:



There is no electron transfer involved and the reactions are solely dependent on pH.

The sloping lines in Figure 2.3 represent equilibria involving both electron transfer and pH; for example:

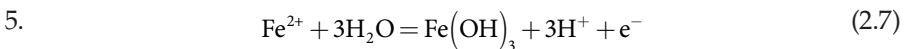

The hydrogen and oxygen are also shown in the diagram by the dotted lines. The hydrogen line represents the equilibria:

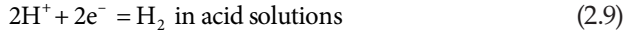

or

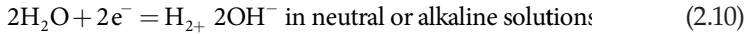

These two reactions are equivalent and their pH dependence of single electrode potential is represented by:

$$E_{\text{H}^+/\text{H}_2} = E_{\text{H}^+/\text{H}_2}^{\circ} - 0.059\text{pH} \quad (2.11)$$

at pH = 0; that is, for $[\text{H}^+] = 1$, $E_{\text{H}^+/\text{H}_2}^{\circ} = 0$ and the slope is -0.059V . Similarly, for oxygen equilibrium with water the corresponding reactions at lower and higher pH are:



and



The pH dependence of single electrode potential is represented by:

$$E_{\text{O}_2/\text{H}_2\text{O}} = E_{\text{O}_2/\text{H}_2\text{O}}^{\circ} - 0.059\text{pH} \quad (2.14)$$

at pH = 0, $E_{\text{O}_2/\text{H}_2\text{O}}^{\circ} = 1.226\text{V}$ and at pH = 1 (i.e., for $[\text{OH}^-] = 1$), $E_{\text{O}_2/\text{H}_2\text{O}}^{\circ} = 0.401\text{V}$. Here again, the slope of the line is -0.059V . Water is stable in the area designated by these two lines. Below the hydrogen line it is reduced to hydrogen gas, and above the oxygen line it is oxidized to oxygen.

The potential–pH diagram shows three clear-cut zones:

1. *Immunity zone.* Under these conditions of potential and pH, iron remains in metallic form.
2. *Corrosion zone.* Under these conditions of potential and pH, iron corrodes, forming Fe^{2+} or Fe^{3+} or HFeO_2^- .

3. *Passive zone.* Under these conditions of potential and pH, protective layers of $\text{Fe}(\text{OH})_3$ form on iron and further corrosion of iron does not take place.

Such diagrams can be used for:

1. Predicting the spontaneous direction of reactions
2. Estimating the stability and composition of corrosion products
3. Predicting environmental changes that will prevent or reduce corrosion

With reference to Figure 2.3, corrosion prevention can be achieved by lowering the electrode potential down to the zone of immunity, raising the electrode potential up to the region of passivity, or raising the pH or alkalinity of the solution so that a passive film is formed.

There are, however, limitations in using such diagrams. The most important of these is that they represent equilibrium conditions and hence cannot be used for predicting the rate of a reaction. The tacit assumption that corrosion products (oxides, hydroxides, etc.) lead to passivity may not always be true because they may not always precipitate on the metal surface. The possibility of precipitation of other ions such as chlorides, sulfates, and phosphates has been ignored. Finally, the pH at the metal surface may vary drastically because of side reactions, and a prediction of corrosion based on the bulk pH of the solution may be misleading.

2.4 Polarization

At an intermediate resistance in the circuit, some current begins to flow and the potentials of both half-cell reactions move slightly toward each other. This change in potential is called *polarization*. The resistance in the circuit depends on a number of factors, including the resistivity of the media, surface films, and the metal itself. The relationships between polarization reactions at each half-cell are represented in Figure 2.4. The intersection of the two polarization lines (curves) closely approximates the corrosion current and the combined cell potentials for the freely corroding situation.

Once the corrosion current is determined, the corrosion density can be calculated by determining the surface area. Using Faraday's laws, a corrosion rate in terms of metal loss per unit time can be determined. However, polarization data can be more useful than just estimating corrosion rates. The extent of polarization can help predict the type and severity of corrosion. As polarization increases, corrosion decreases. Polarization may

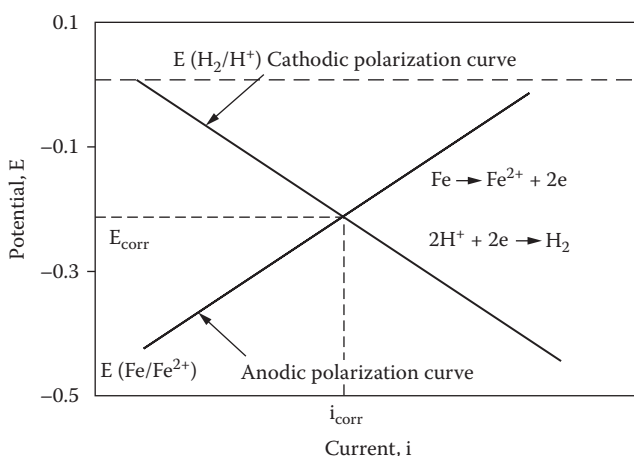

FIGURE 2.4
Polarization of iron in acid.

be preferable to either cathodic or anodic reactions. Understanding the influence of environmental changes on polarization can offer insight into controlling corrosion. For example, in the iron–hydrochloric acid example, hydrogen gas formation at the cathode can actually slow the reaction (increased current resistance) by blocking access of hydrogen ions to the cathode site. This results in cathodic polarization and lowers the current flow and corrosion rate. If oxygen is bubbled through the solution, the hydrogen is removed more rapidly by combining to form water and the corrosion rate increases significantly. Although this is an oversimplified view of the effects of oxygen, it does indicate that the degree of polarization can be affected by changes in the environment, either natural or induced.

There are three basic causes of polarization, termed activation, concentration, and potential drop. Potential drop is the change in voltage associated with effects of the environment and the circuit between the anode and cathode sites. It includes the effects of the resistivity of the media, surface films, corrosion products, etc.

2.4.1 Activation Polarization

Activation polarization arises out of a slow step in the electrode reaction for which an activation energy in the form of an increment in potential is required for the reaction to proceed. This will best be illustrated by the hydrogen evolution reaction.

The hydrogen evolution reaction consists of several steps as shown in Figure 2.5. Either the electron transfer step (step 2) or the formation of

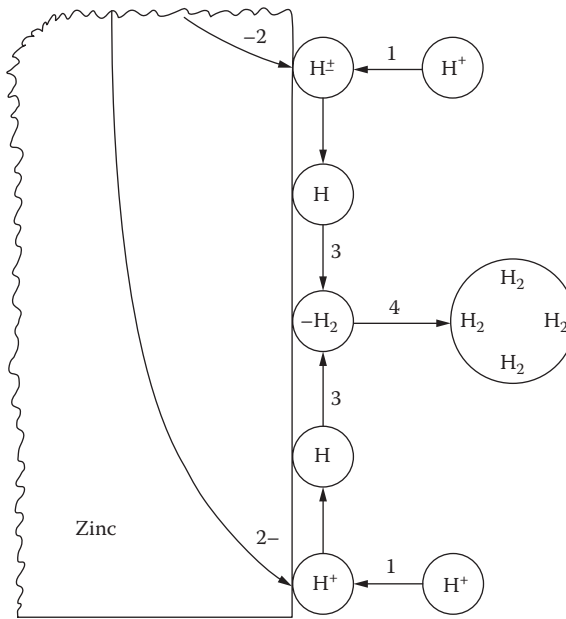

FIGURE 2.5

Steps involved in hydrogen reduction reaction.

hydrogen molecules (step 3) is deemed the slowest step in the reaction sequence, and the rate of overall reaction will depend on how fast or slow it proceeds. Therefore, to have a higher rate of reaction, expressed in terms of increased current density, an increase in potential should be effected. The relationship between reaction rate and change in potential (overvoltage) is expressed by the Tafel equation:

$$\eta_a = \pm \beta \log \frac{i}{i_0} \quad (2.15)$$

where η_a is overvoltage polarization (in volts), and β is a constant, called the Tafel constant (also expressed in volts), and is usually on the order of 0.1V.

A graphical representation of Equation 2.15, as applied to the hydrogen evolution reaction, with a β slope of 0.1V is shown in Figure 2.6. It can be noted from the graph that 0.1V change in overvoltage can effect a tenfold increase or decrease in the reaction rate.

Dissolution reactions (anodic) in corrosion are usually controlled by activation polarization where the solution of ions is the probable rate-controlling step. Hydrogen evolution reactions (cathodic reactions) are controlled by activation polarization when the concentration of hydrogen ions is high.

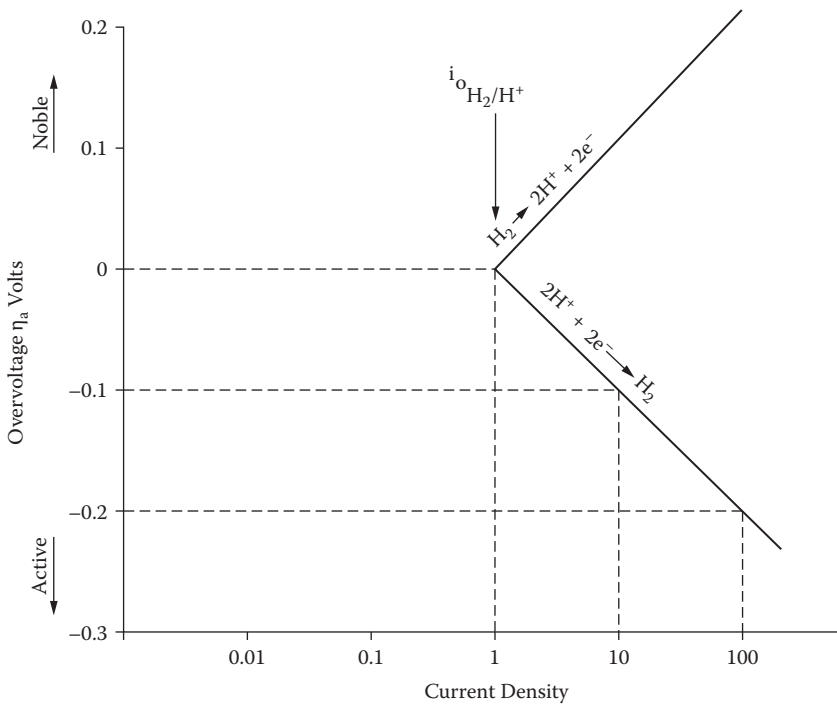

FIGURE 2.6
Activation polarization curve of a hydrogen electrode.

2.4.2 Concentration Polarization

A buildup or depletion of ions at the electrode surface as a result of reaction will change the value of the electrode potential according to the Nernst equation. For example, for a corroding zinc electrode, the concentration of zinc will increase with dissolution in the vicinity of the electrode. The value of a_{oxid} in the equation increases, causing the electrode potential to shift in a positive direction.

For the hydrogen evolution reaction, the higher rate of discharge of hydrogen ions at the electrode surface brings down the value of a_{oxid} and the electrode potential, according to the Nernst equation, shifts in a negative direction. However, the rate of discharge of hydrogen ions at the electrode surface depends on the diffusion of hydrogen ions from the bulk of the solution to the surface:

$$i_1 = \frac{DnFC}{x} \quad (2.16)$$

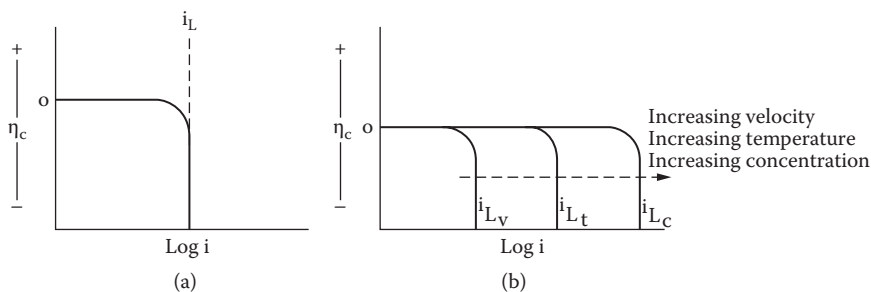
**FIGURE 2.7**

(a) Concentration polarization curve for reduction process, and (b) effect of environmental variations on concentration polarization curve.

where i_l is called the limiting diffusion current density (amp/cm^2), D is the diffusion coefficient for H^+ ion, n is the number of electrons transferred, F is the Faraday number, C is the bulk concentration of H^+ ions in the solution, and x is the thickness of the diffusion layer adjacent to the electrode surface through which the concentration of the reacting species (H^+ ions) changes from C in the bulk to zero at the electrode surface.

A mathematical expression for concentration polarization involves i_l and is given by:

$$\eta_c = \frac{2.3RT}{F} \log \left(1 - \frac{i}{i_l} \right) \quad (2.17)$$

where η_c is overvoltage due to concentration polarization (in volts). A graphical representation of the equation is shown in Figure 2.7.

It can be seen from the graph in Figure 2.7 as well as from Equation 2.17 that as i approaches i_l , η_c tends to infinity. As evident from Equation 2.16, factors such as increasing velocity (smaller x), increasing temperature (higher D), and increasing concentrations will increase the value of i_l , that is, a shift in the vertical position of the curve in Figure 2.7 more toward the right.

There is no question of concentration polarization when the supply of reacting species is abundant. Hence, in metal dissolution reactions, its effect is negligible as the supply of metal atoms for dissolution is unlimited. On the other hand, for a hydrogen evolution reaction, concentration polarization becomes significant in the solutions of low H^+ concentration. More often, the reduction process is controlled by a combined polarization — that is, activation polarization at lower reaction rates and concentration polarization at higher reaction rates — as i approaches i_l . A graphical representation of such combined polarization is shown in Figure 2.8.

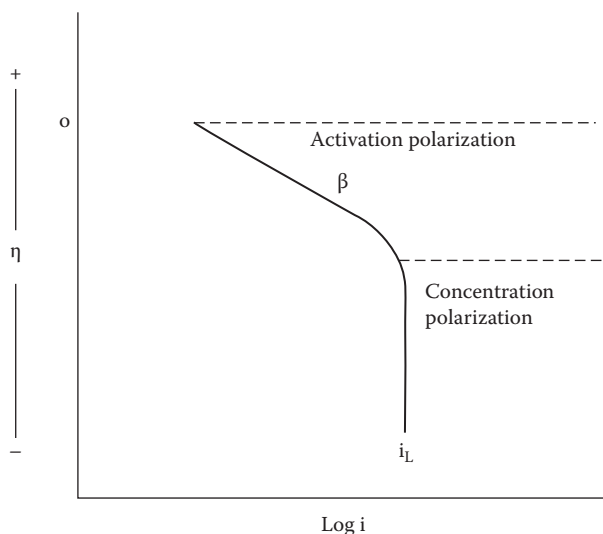
**FIGURE 2.8**

Combined curve of activation and concentration polarizations for reduction process.

2.5 Measuring Polarization

While polarization always leads to lower rates of corrosion, identifying the effects of the environment on polarization of the corrosion circuit is useful in predicting corrosion behavior. Measurement of the corrosion circuit while the corrosion potential is varied is possible with the apparatus shown in Figure 2.9.

Turning to the example of iron corroding in hydrochloric acid solution, if the iron sample is maintained at the natural corrosion potential of -0.2V , no current will flow through the auxiliary electrode. The plot of this data point in the study would equate to that of A or C in Figure 2.10. As the potential is raised, anodically polarized, the current flow will increase and curve AB will approximate the behavior of the true anodic polarization curve. Alternatively, if the potential were lowered below -0.2V , the current measurements would result in the curve CD and approximate the nature of the cathodic polarization curve. By using the straight-line portion of the Tafel regions of these curves, an approximation of the corrosion current can be made.

Most often it is the anodic polarization behavior that is useful in understanding alloy systems in various environments. Anodic polarization tests can be conducted with relatively simple equipment and the scans themselves can be done in a short time. They are extremely useful in studying the active-passive behavior that many materials exhibit. As the name suggests, these

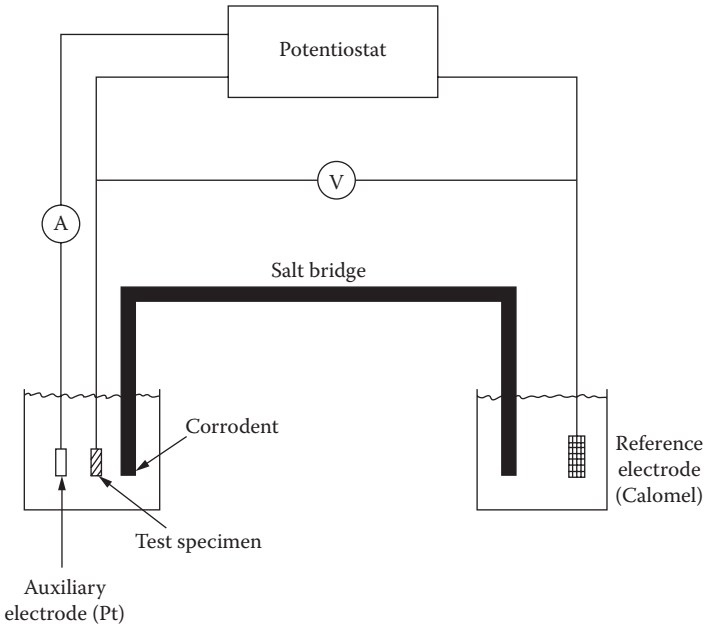

FIGURE 2.9
Anode polarization measurement apparatus.

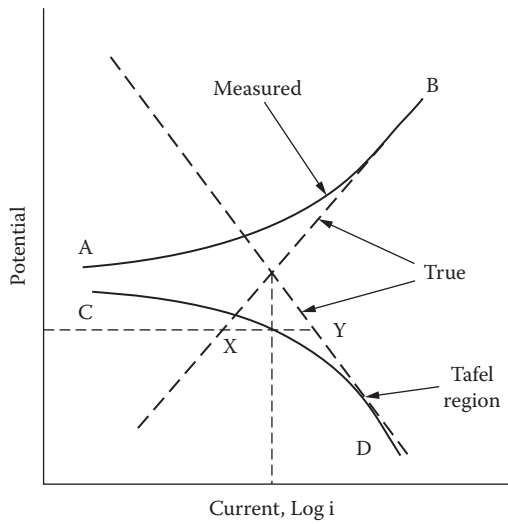

FIGURE 2.10
Anodic and cathodic polarization curve.

materials can exhibit both a highly corrosion-resistant behavior and that of a material that corrodes actively, while in the same corrodent. Metals that commonly exhibit this type of behavior include iron, titanium, aluminum, chromium, and nickel. Alloys of these materials are also subject to this type of behavior.

Active-passive behavior depends on the material–corrodent combination and is a function of the anodic or cathodic polarization effects that occur in that specific combination. In most situations where active-passive behavior occurs, there is a thin layer at the metal surface that is more resistant to the media than the underlying metal. In stainless steels, this layer is composed of various chromium and/or nickel oxides that exhibit substantially different electrochemical characteristics than the underlying alloy. If this resistant, or passive layer is damaged while in aggressive media, active corrosion of the freshly exposed surface will occur. The damage to this layer can be either mechanical or electrochemical in nature.

The behavior of iron in nitric acid underscores the importance of recognizing the nature of passivity. Iron is resistant to corrosion in nitric acid at concentrations around 70%. Once passivated under these conditions, it can also exhibit low rates of corrosion as the nitric acid is diluted. However, if this passive film is disturbed, rapid corrosion will begin and repassivation will not be possible until the nitric acid concentration is raised to a sufficient level.

2.5.1 Anodic Polarization

Active-passive behavior is schematically represented by the anodic polarization curve as shown in Figure 2.11. Starting at the base of the plot, the curve starts out with a gradually increasing current as expected. However,

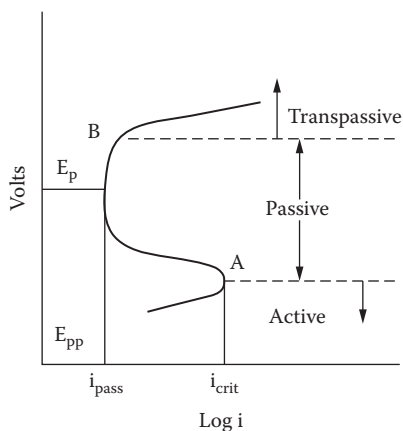

FIGURE 2.11

Anodic polarization curve for material exhibiting active-passive behavior.

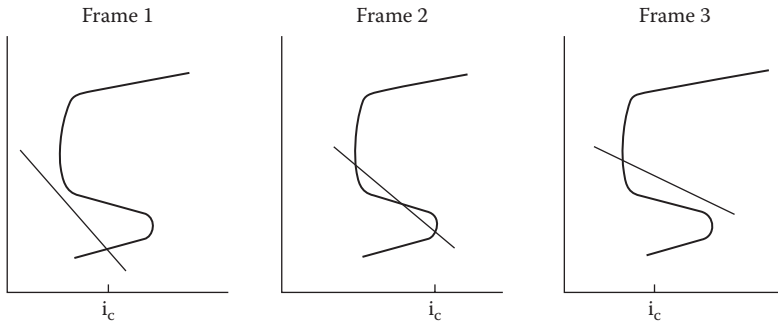

FIGURE 2.12

Schematic representation of a material with active-passive behavior in different corrosive environments.

at point A there is a dramatic polarizing effect that drops the current to a point where corrosion is essentially halted. As this potential is increased further, there is little change in current flow until the next critical stage B, where a breakdown of the passive film occurs and the current again begins to rise.

Even with an established anodic polarization behavior, the performance of a material can vary greatly with relatively minor changes in the corrodent. This is also illustrated in Figure 2.12. Frame 1 illustrates the case where the anodic and cathodic polarization curves intersect much the same as in materials with no active-passive behavior. The anode is actively corroding at a high but predetermined rate.

Frame 2 represents the condition often found perplexing when using materials that exhibit active-passive behavior. With relatively minor changes within the system, the corrosion current could be very low when the material is in the passive state or very high when active corrosion begins.

Frame 3 in Figure 2.12 typifies the condition sought after when using materials in the passive state. In this example, the cathodic polarization curve intersects only in the passive region, resulting in a stable and low corrosion current. This type of system can tolerate moderate upset conditions without the onset of accelerated corrosion.

The anodic polarization technique is also useful in studying the effects of variations in the environment and the benefits of alloy additions. As illustrated in Figure 2.13, temperature increases cause a shift of the curve to higher currents. Increasing chromium content in steel expands the passive region significantly, and adding molybdenum raises the potential required for the initiation of pitting-type attack. The presence of chloride or other strong oxidizing ions will shrink the passive region.

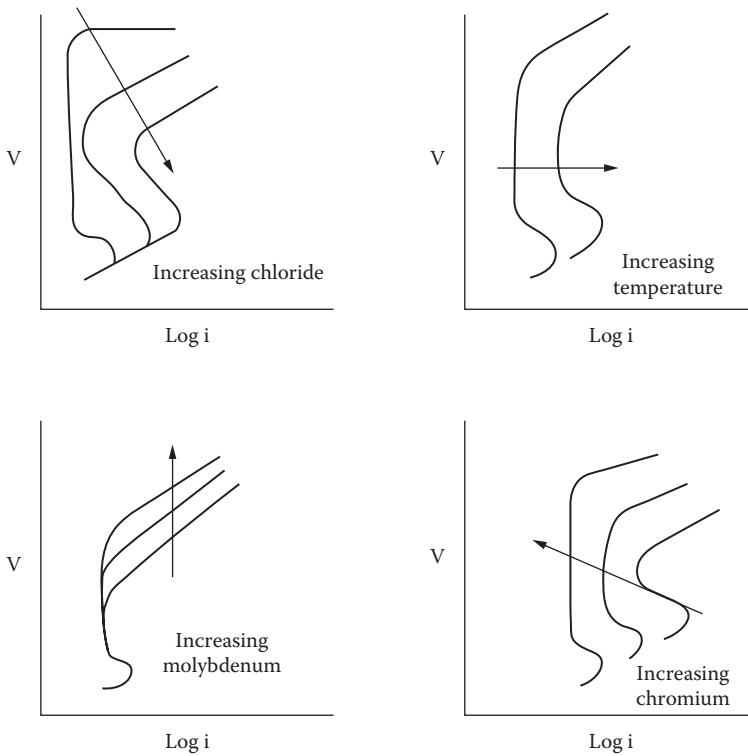

FIGURE 2.13
Effects of environment and alloy content on anodic polarization behavior.

2.6 Other Factors Affecting Corrosion

Temperature can have a significant influence on the corrosion process. This is not unexpected because it is an electrochemical reaction and reaction rates do increase with increasing temperature. There are additional influences on corrosion other than the corrodent itself.

The relative velocities between the component and the media can have a direct effect on the corrosion rate. In some instances, increasing the velocity of the corrodent over the surface of the metal will increase the corrosion rate. When concentration polarization occurs, the increased velocity of the media will disperse the concentrating species. However, with passive materials, increasing the velocity can actually result in lower corrosion rates. This occurs because the increased velocity shifts the cathodic polarization curve such that it no longer intersects the anodic polarization curve in the active corrosion region, as shown in Figure 2.14.

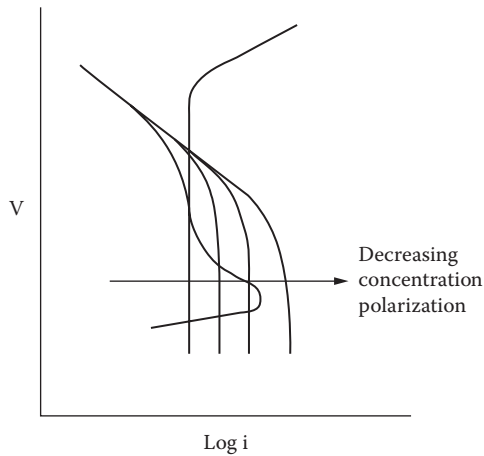

FIGURE 2.14

Increased corrodent velocity can shift the cathodic polarization curve such that passive behavior can be induced.

The surface finish of the component also has an impact on the mode and severity of the corrosion that can occur. Rough surfaces or tight crevices can facilitate the formation of concentration cells. Surface cleanliness can also be an issue, with deposits or films acting as initiation sites. Biological growths can behave as deposits or change the underlying surface chemistry to promote corrosion.

Other variations within the metal surface on a microscopic level influence the corrosion process. Microstructural differences such as secondary phases or grain orientation will affect the way corrosion manifests itself. For corrosive environments where grain boundaries are attacked, the grain size of the material plays a significant role in how rapidly the material's properties deteriorate. Chemistry variations in the matrix of weld deposits are also a factor.

Radiation can have an effect on a material's properties. The effect on metallic materials is very gradual and not very pronounced. Stresses, either residual or applied, impact the mode of corrosion and lower the energy needed for corrosion to begin. Stress is a requirement for stress corrosion cracking (which will be discussed later) or corrosion fatigue, but can also influence the rate of general corrosion.

Finally, time is a factor in determining the severity of corrosion. Corrosion rates are expressed using a time dimension. Some corrosion processes are violent and rapid while most are so slow as to be imperceptible on a day-to-day basis. Equipment is planned to provide a useful service life. A chief goal in understanding corrosion is the proper selection of materials, equipment, processes, or controls to optimize our natural and financial resources.

2.7 Corrosion Rate Measurement

Measurement of corrosion is essential for the purpose of material selection. The compatibility of a metal with its environment is a prime requirement for its reliable performance. Corrosion rate measurement may become necessary for the evaluation and selection of materials for a specific environment, a given definite application, or for the evaluation of a new or old metal or alloys to determine the environments in which they are suitable. Often, the corrosive environment is treated to make it less aggressive, and corrosion rate measurements of a specific material in untreated environments will reflect the efficacy of the treatment. In addition, corrosion rate measurement is also essential in the study of the mechanisms of corrosion.

2.7.1 Corrosion Rate Expressions

Corrosion involves dissolution of metal, as a result of which the metallic part loses its mass (or weight) and becomes thinner. Corrosion rate expressions are therefore based on either weight loss or penetration into the metal.

The most widely used weight expression, based on weight loss, is mg/dm²/day (mdd) and the rate expression on penetration is inch penetration/year (ipy) and mils penetration/year (mpy). One mil is one thousandth of an inch. The last expression is very convenient because it does not involve a decimal point or zeroes. Thus, 0.002 ipy is simply expressed as 2 mpy. The expression is readily calculated from the weight loss of the metal specimen during the corrosion test by the empirical formula:

$$\text{mpy} = \frac{534W}{DA t} \quad (2.18)$$

where W is weight loss (mg), D is density of metal (g/cm³), A is area of specimen (in.²), t is exposure time (h), and mdd and mpy are convertible through the following multiplying factors:

$$\text{mpy} = \frac{1.44 \text{ mdd}}{\text{density}} \quad (2.19)$$

$$\text{mdd} = \text{mpy} (0.696) (\text{density}) \quad (2.20)$$

Conversion factors for the above equations are given in Table 2.2.

TABLE 2.2

Conversion Factors from Inches per Year (ipy) to
Milligrams per Square Decimeter per Day (mdd)

Metal	Density (g/cm³)	0.00144 Density ($\times 10^{-3}$)	696 \times Density
Aluminum	2.72	0.529	1890
Brass (red)	8.75	0.164	6100
Brass (yellow)	8.47	0.170	5880
Cadmium	8.65	0.167	6020
Columbium	8.4	0.171	5850
Copper	8.92	0.161	6210
Copper-nickel (70/30)	8.95	0.161	6210
Iron	7.87	0.183	5480
Duriron	7.0	0.205	4870
Lead (chemical)	11.35	0.127	7900
Magnesium	1.74	0.826	1210
Nickel	8.89	0.162	6180
Monel	8.84	0.163	6140
Silver	10.50	0.137	7300
Tantalum	16.6	0.0868	11550
Titanium	4.54	0.317	3160
Tin	7.29	0.198	5070
Zinc	7.14	0.202	4970
Zirconium	6.45	0.223	4490

Note: Multiply ipy by (696 \times density) to obtain mdd. Multiply
mdd by (0.00144/density) to obtain ipy.

3

Forms of Metallic Corrosion

The mechanisms of metallic corrosion were discussed in Chapter 2. The various mechanisms can result in different forms or types of corrosion, as discussed in this chapter. The primary forms of corrosion are as follows:

- General (uniform) corrosion
- Intergranular corrosion
- Galvanic corrosion
- Crevice corrosion
- Pitting corrosion
- Erosion corrosion
- Stress corrosion cracking
- Biological corrosion
- Selective leaching
- Hydrogen damage
- Liquid metal attack
- Exfoliation
- Corrosion fatigue
- Filiform corrosion

Each form of corrosion and the conditions responsible for its initiation are discussed.

3.1 General (Uniform) Corrosion

Although other forms of attack must be considered in special circumstances, uniform attack is one form most commonly confronting the user of metals and alloys. Uniform (or general) corrosion, which is the simplest form of corrosion, is an even rate of metal loss over the exposed surface. It is generally thought of as metal loss due to chemical attack or dissolution of the metallic component into metallic ions. In high-temperature situations, uniform metal loss is usually preceded by its combination with another element rather than

its oxidation to a metallic ion. Combination with oxygen to form metallic oxides, or scale, results in the loss of material in its useful engineering form; scale ultimately flakes off to return to nature.

A metal resists corrosion by forming a passive film on the surface. This film is formed naturally when the metal is exposed to the air for a period of time. It can also be formed more quickly by chemical treatment. For example, nitric acid, if applied to austenitic stainless steel, will form this protective film. Such a film is actually corrosion but once formed, it prevents further degradation of the metal, provided that the film remains intact. It does not provide an overall resistance to corrosion because it may be subject to chemical attack. The immunity of the film to attack is a function of the film composition, temperature, and the aggressiveness of the chemical. Examples of such films are the patina formed on copper, the rusting of iron, the tarnishing of silver, the fogging of nickel, and the high-temperature oxidation of metals.

There are two theories regarding the formation of this film. The first theory states that the film formed is a metal oxide or other reaction compound. This is known as the oxide film theory. The second theory states that oxygen is adsorbed on the surface, forming a chemisorbed film. However, all chemisorbed films react over a period of time with the underlying metal to form metal oxides. Oxide films are formed at room temperature. Metal oxides can be classified as network formers, intermediates, or modifiers. This division can be related to thin oxide films on metals. The metals that fall into network-forming or intermediate classes tend to grow protective oxides that support anion or mixed anion/cation movement. The network formers are noncrystalline, whereas the intermediates tend to be macrocrystalline at low temperatures.

3.1.1 Passive Film on Iron

Iron in iron oxides can assume a valence of two or three. The former acts as a modifier and the latter as a network former. The iron is protected from the corrosion environment by a thin oxide film 1 to 4 μm in thickness with a composition of $\sqrt{\text{Fe}_2\text{O}_3}/\text{Fe}_3\text{O}_4$. This is the same type of film formed by the reaction of clean iron with oxygen or dry air. The $\sqrt{\text{Fe}_2\text{O}_3}$ layer is responsible for the passivity, while the Fe_3O_4 provides the basis for the formation of a higher oxidation state. Iron is more difficult to passivate than nickel because with iron it is not possible to go directly to the passivation species $\sqrt{\text{Fe}_2\text{O}_3}$. Instead, a lower oxidation state of Fe_3O_4 is required and the film is highly susceptible to chemical dissolution. The $\sqrt{\text{Fe}_2\text{O}_3}$ layer will not form until the Fe_3O_4 phase has existed on the surface for a reasonable period of time. During this time, the Fe_3O_4 layer continues to form.

3.1.2 Passive Film on Nickel

The passive film on nickel can be formed quite readily, in contrast to the formation of the passive film on iron. Differences in the nature of the oxide film on iron and nickel are responsible for this phenomenon. The thickness of the oxide film on nickel is between 0.9 and 1.2 mm, whereas the iron oxide film is between 1 and 4 mm. There are two theories as to what the passive film on nickel is. It is either entirely NiO with a small amount of nonstoichiometry, giving rise to Ni³⁺ cation vacancies, or it consists of an inner layer of NiO and an outer layer of anhydrous Ni(OH)₂. The passive oxide film on nickel, once formed, cannot be easily removed by either cathodic treatment or chemical dissolution.

The passive film on nickel will not protect the nickel from corrosive attack in oxidizing atmospheres, such as nitric acid. When alloyed with chromium, a much improved, stable film results, producing a greater corrosion resistance to a variety of oxidizing media. However, these alloys are subject to attack in environments containing chlorides or other halides, especially if oxidizing agents are present. Corrosion will be in the form of pitting. The addition of molybdenum or tungsten will improve the corrosion resistance.

3.1.3 Passive Film on Austenitic Stainless Steel

The passive film on austenitic stainless steel is duplex in nature, consisting of an inner barrier oxide film and an outer deposit of hydroxide or salt film. Passivation takes place by the rapid formation of surface-absorbed hydrated complexes of metals that are sufficiently stable on the alloy surface that further reaction with water enables the formation of a hydroxide phase that rapidly deprotonates to form an insoluble surface oxide film. The three most commonly used austenite stabilizers — nickel, manganese, and nitrogen — all contribute to the passivity. Chromium, a major alloying ingredient, is in itself corrosion resistant and is found in greater abundance in the passive film than iron, which is the major element in the alloy.

3.1.4 Passive Film on Copper

When exposed to the atmosphere for long periods of time, copper will form a coloration on the surface known as patina. In reality, the coloration is a corrosion product that acts as a protective film against further corrosion. When first formed, the patina exhibits a dark color that gradually turns green. The length of time required to form the patina depends upon the atmosphere because the coloration is given by copper hydroxide compounds. In a marine atmosphere, the compound is a mixture of copper/hydroxide/chloride; in industrial atmospheres, it is copper/hydroxide/sulfate. These compounds will form in approximately 7 years. When exposed in a clean rural atmosphere, tens or hundreds of years may be required to form the patina.

3.1.5 Passive Film on Aluminum

Aluminum forms a thin, compact, adherent oxide film on the surface that limits further corrosion. When formed in air at atmospheric temperatures, it is approximately 5 nm thick. If formed at elevated temperatures or in the presence of water or water vapor, it will be thicker. The oxide film is stable in the pH range from 4 to 9. With a few exceptions, the film will dissolve at lower or higher pH ranges. Exceptions are concentrated nitric acid (pH 1) and concentrated ammonium hydroxide (pH 13). In both cases, the oxide film is stable.

The oxide film is not homogeneous and contains weak points. Breakdown of the film at weak points leads to localized corrosion with increasing alloy content; and on heat-treatable alloys, the oxide film becomes more nonhomogeneous.

3.1.6 Passive Film on Titanium

Titanium forms a stable, protective, strongly adherent oxide film. This film forms instantly when a fresh surface is exposed to air or moisture. Addition of alloying elements to titanium affects the corrosion resistance because these elements affect the composition of the oxide film.

The oxide film of titanium is very thin and is attacked by only a few substances, the most notable of which is hydrofluoric acid. Because of its strong affinity to oxygen, titanium is capable of healing ruptures in this film almost instantly in any environment when a trace of moisture is present.

3.1.7 Passive Film on Tantalum

When exposed to oxidizing or slightly anodic conditions, tantalum forms a thin impervious layer of tantalum oxide. This passivating oxide has the broadest range of stability with regard to chemical attack or to thermal breakdown compared to other metallic films. Chemicals or conditions that attack tantalum, such as hydrofluoric acid, are those that penetrate or dissolve the film.

3.1.8 Uniform Corrosion Rates

When exposed to a corrosion medium, metals tend to enter into a chemical union with the elements of the corrosion medium, forming stable compounds similar to those found in nature. When metal loss occurs in this manner, the compound is referred to as the *corrosion product* and the surface is referred to as having been corroded. An example of such an attack is that of halogens, particularly chlorides. They will react with and penetrate the film on stainless steel, resulting in general corrosion. Corrosion tables were developed to indicate the interaction between a chemical and a metal. This type of attack is called general or uniform corrosion. It is one of the most easily measured and predictable forms of corrosion. Many references exist that

report average or typical rates of corrosion for various metals in common media (see, for example Reference 1).

Because corrosion is so uniform, corrosion rates for materials are often expressed in terms of metal thickness loss per unit of time. The rate of uniform attack is often reported in various units. One common expression is mils per year (mpy). Refer to Chapter 2 for a more complete discussion of the various units used to measure loss.

Because of its predictability, low rates of corrosion are often tolerated and catastrophic failures are rare if planned inspection and monitoring are implemented. For most chemical process equipment and structures, general corrosion rates of less than 3 mpy are considered acceptable. Rates between 3 and 20 mpy are routinely considered useful engineering materials for the given environment. In severe environments, materials exhibiting high corrosion rates, between 20 and 50 mpy, might be considered economically justifiable. Materials that exhibit rates of general corrosion beyond this are usually unacceptable. It should be remembered that not only must the metal loss be considered, but where the metal is going must also be considered. Contamination of product, even at low concentrations, can be more costly than the replacement of the corroded component.

Examples of uniform or general corrosion are illustrated by a steel tank or steel roof rusting in the atmosphere, or a piece of zinc dissolving in hydrochloric acid.

Atmospheric corrosion is also an example of uniform corrosion, and takes place under damp or wet conditions. A more detailed discussion of atmospheric corrosion is found in Chapter 4.

3.1.9 Protective Measures

The single most important protective measure is the selection of the proper material of construction. Many corrosion-resistant alloys have been developed, of which the most widely used are the stainless steels. However, these are not a cure-all. To provide protection where the stainless steels are unable to resist the corrosion, other alloys and/or metals have been developed to fill the voids. For example, to prevent the atmospheric corrosion of steel, special weathering steels have been developed. These are steels containing small amounts of copper or micro-alloyed steels containing copper, phosphorus, nickel, or chromium. The rust formed on these steels is adherent and protective.

In some cases, a less expensive material of construction may be used when a protective coating or lining is applied to provide protection against the corrosive media.

Another option is to provide a *corrosion allowance*. If a vessel showing a corrosion rate of 6 mpy is to have a 10-year life, an additional wall thickness of 60 mils (or 0.06 inch) will be provided above what is required to meet the operating conditions of pressure, temperature, and stress.

It is common practice for the prevention of uniform corrosion to make use of such measures as the application of protective coatings or linings, the use of inhibitors, and the use of cathodic or anodic protection.

3.2 Intergranular Corrosion

This is a specialized type of attack that takes place at the grain boundaries of a metal. Little or no attack is observed on the main body of the grain. The grain boundary material, which is a limited area, acts as an anode, and the larger area of grains acts as cathodes. This results in the flow of energy from the small anode area to the large cathode area, which causes rapid attack penetrating deeply into the metal.

The grain boundary region is an area of crystallographic mismatch between the orderly structures within the adjacent grains. Because of this, it is slightly chemically more active than the grain area. Under certain conditions, the grain boundaries remain very reactive; and under corrosive conditions, the attack along the grain boundaries results in intergranular corrosion (IGC).

The following factors contribute to the increased reactivity of the grain boundary areas:

1. Segregation of specific elements or compounds, as in aluminum alloys or nickel-chromium alloys
2. Enrichment of one of the alloying elements at the grain boundary, as in brass
3. Depletion of the corrosion-resistant element at the grain boundary, as in stainless steels

All the factors that lead to intergranular corrosion are the result of the thermal exposure of the metals, such as in welding, stress relief, and other heat treatments.

3.2.1 Austenitic Stainless Steels

When austenitic stainless steels are heated or cooled through the temperature range of about 800 to 1650°F (427 to 899°C), the chromium along the grain boundaries tends to combine with carbon to form chromium carbides. Called sensitization, or carbide precipitation, the effect is a depletion of chromium and the lowering of corrosion resistance in the areas adjacent to the grain boundary. This is a time-temperature phenomenon, as in Figure 3.1.

Slow cooling from annealing temperature, stress relieving in the sensitization range, or welding may cause carbide precipitation. The sensitization of

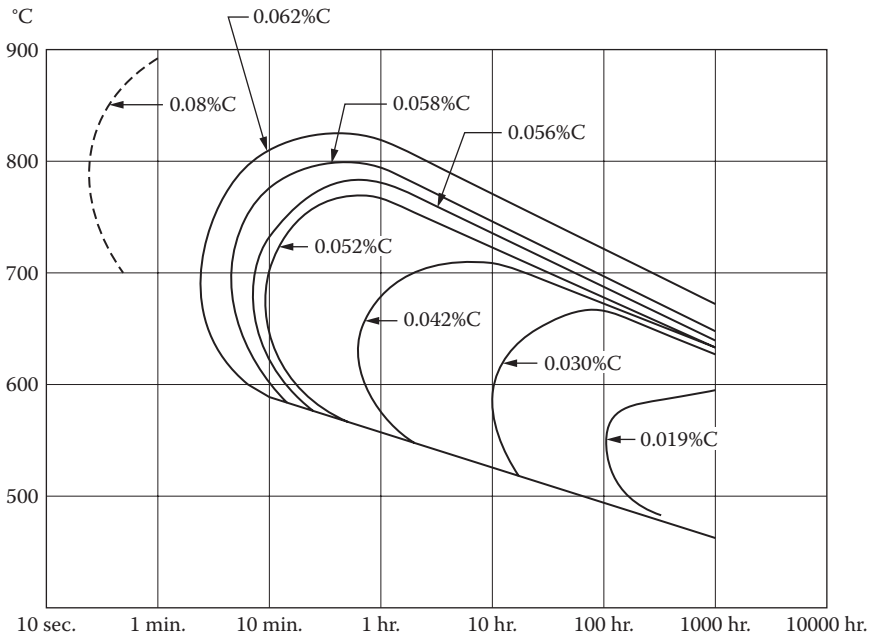

FIGURE 3.1

Effect of carbon content on carbide precipitation. Carbide precipitation forms in the areas to the right of the various carbon content curves.

stainless steel during welding is known as *weld decay*. The affected zone is usually a band in the parent plate somewhat removed from the weld bead. When exposed to corrosive environments, intergranular corrosion takes place in this zone and the attack gives a granular appearance. During welding, this area remains in the sensitizing temperature range for a sufficient length of time to permit carbide precipitation, whereas at the weld pool and its adjacent areas the temperature is high enough and the time insufficient for the precipitation to take place. Areas further away from this weld decay zone do not reach the sensitizing temperature and therefore carbide precipitation does not occur.

Due to the longer times at the temperature of annealing or stress relieving, it is possible that the entire piece of material will be sensitized, whereas shorter times at welding temperature can result in sensitization of a band usually 1/8 to 1/4 in. wide, adjacent to but slightly removed from the weld. This region is known as the heat-affected zone (HAZ).

Intergranular corrosion depends on the magnitude of the sensitization and the aggressiveness of the environment to which the sensitized material is exposed. Many environments do not cause intergranular corrosion in sensitized stainless steels.

For this form of attack to occur, there must be a specific environment. Many environments do not cause intergranular corrosion in stainless steels. Acids containing oxidizing agents, such as phosphoric acid containing ferric or cupric ions and nitric acid, as well as hot organic acids such as acetic and formic acids, are highly specific for this type of attack. Seawater and other high chloride waters cause severe pitting in sensitized areas, but low chloride waters (e.g., potable water) do not, except in specific situations such as might occur under the influence of microbiological corrosion.

If the carbon content is held to less than 0.030%, chromium carbide precipitation can still occur upon sensitization, but in such small amounts that no significant chromium depletion occurs. Such low carbon grades are practically immune to weld decay. However, sensitization can occur under prolonged heating in the critical temperature range, such as during service at elevated temperatures, or during very prolonged thermal stress relief. Refer to Figure 3.1. For all practicality, the low carbon grades can be welded, hot formed, and even thermally stress relieved without sensitizing occurring.

Sensitization can also be prevented using stabilized stainless steels. These are stainless steels to which titanium, columbium (niobium), or niobium-titanium mixtures have been added.

Titanium and niobium additions equal to five or ten times the carbon content, respectively, permit the carbon to precipitate as titanium or niobium carbides during a sensitizing heat treatment. The carbon precipitation does not reduce the chromium content at the grain boundaries.

Three problems are presented by this approach. First, titanium-stabilized grades, such as type 321, require a stabilizing anneal to tie up the carbon in the form of titanium carbide before welding. Second, titanium does not transfer well across a welding arc and thus loses much of its effectiveness in multipass or cross-welding. Third, although niobium does not have this drawback, the niobium carbides (as can the titanium carbides) can be redissolved by the heat of welding. Consequently, multipass or cross-welding can first redissolve titanium or niobium carbide and then permit carbide precipitation in the fusion zone (not the HAZ). This can cause a highly localized form of intergranular corrosion known as knife-line attack, seen particularly in alloys such as type 347, alloy 20Cb3, and alloy 825.

Titanium and niobium carbides precipitate at higher temperatures than chromium carbides. For example, niobium carbide precipitates in the temperature range of 1498 to 2246°F (815 to 1230°C) where chromium carbide dissolves. During stabilization (cooling down from the melt), niobium carbide will form in this temperature range, leaving no carbon to form chromium carbide at temperatures below 1498°F (815°C). However, above 2246°F (1230°C), niobium carbide dissolves. When a stabilized steel is heated above 2246°F (1230°C), all carbides are dissolved, and a rapid cooling to room

temperature prevents the carbides from precipitating. This is what occurs in the area adjacent to the weld. When the weldment is stress relieved at 932 to 1472°F (500 to 800°C), or is in service in this temperature range, chromium carbide forms and sensitization takes place; even if niobium is present in the alloy, it cannot prevent chromium carbide from forming because niobium carbide requires a higher temperature to form. The same is true for titanium-stabilized alloys.

3.2.2 Ferritic Stainless Steels

Ferritic stainless steels are also subject to sensitization and intergranular corrosion as a result of chromium depletion. However, there are differences between the sensitization of the austenitic stainless steels and the ferritic stainless steels. Because the solubility of nitrogen is low in austenitic stainless steels, the percentage of chromium nitride is not a prime factor for sensitization. However, this is a prime factor in ferritic stainless steels for sensitization. A second difference lies in the temperature range of sensitization, which is above 1696°F (925°C), where the solubility of carbon and nitrogen is significant in ferrite. As a result of this difference in the sensitizing temperature range, the zone of intergranular corrosion differs. The attack in ferritic steels occurs at areas adjacent to the weld or in the weld itself.

By heating the sensitized steel between 1201 and 1498°F (650 and 815°C), immunity to intergranular corrosion is restored.

3.2.3 Other Alloys

Nickel-based alloys can also be subjected to carbide precipitation of intermetallic phases when exposed to temperatures lower than their annealing temperatures. As with austenitic stainless steels, low-carbon-content alloys are recommended to delay precipitation of carbides. In some alloys, such as alloy 625 niobium (columbium), titanium, or tantalum is added to stabilize the alloy against precipitation of chromium or molybdenum carbides. These elements combine with carbon instead of chromium or molybdenum.

Precipitation-hardenable nickel alloys such as Inconel X-750 are susceptible to intergranular corrosion in hot caustic solutions, in boiling 75% nitric acid, and in high-temperature water containing low concentrations of other salts. Inconel 600 is also susceptible in the same media when thermally treated in the range of 1004 to 1400°F (540 to 760°C).

Copper alloy 260 (70–30 brass) is subject to intergranular corrosion in dilute aqueous solutions of H_2SO_4 , Fe_2SO_4 , BiCl_3 , and other electrolytes.

Red-fuming nitric acid at room temperature will cause intergranular corrosion of titanium. Addition of 1% NaBr will inhibit the attack.

3.3 Galvanic Corrosion

This form of corrosion is sometimes referred to as dissimilar metal corrosion, and is found in unusual places, often causing professionals the most headaches. Galvanic corrosion is often experienced in older homes where modern copper piping is connected to the older existing carbon steel piping. The coupling of the carbon steel to the copper causes the carbon steel to corrode. The galvanic series of metals provides details of how galvanic current will flow between two metals and which metal will corrode when they are in contact or near each other and an electrolyte is present (e.g., water). Table 3.1 lists the galvanic series.

When two different metallic materials are electrically connected and placed in a conductive solution (electrolyte), an electric potential exists. This potential difference will provide a stronger driving force for the dissolution of the less noble (more electrically negative) material. It will also reduce the tendency for the more noble metal to dissolve. Notice in Table 3.1 that the precious metals gold and platinum are at the higher potential (more noble or cathodic) end of the series (protected end), while zinc and magnesium are at the lower potential (less noble or anodic) end. It is this principle that forms the scientific basis for using such materials as zinc to sacrificially protect the stainless steel drive shaft on a pleasure boat. When placed alone in corrosive media, both members may corrode, but at different rates. The metal having the higher corrosion rate will become the corroding member in the couple (anode). The other member becomes the cathode. The cathode may suffer from hydrogen damage while galvanic corrosion is taking place on the cathode.

Note that several materials are shown in two places in the galvanic series being indicated as either active or passive. This is the result of the tendency of some metals and alloys to form surface films, especially in oxidizing environments. This film shifts the measured potential in the noble direction. In this state, the material is said to be passive.

The particular way in which a metal will react can be predicted from the relative positions in the galvanic series. When it is necessary to use dissimilar metals, two materials should be selected that are relatively close in the galvanic series. The farther apart the metals are in the galvanic series, the greater the rate of corrosion. The rate of corrosion is also affected by the relative areas between the anode and cathode. Because the flow of current is from the anode to the cathode, the combination of a large cathodic area and a small anodic area is undesirable. Corrosion of the anode can be 100 to 1000 times greater than if the two areas were equal. Ideally, the anodic area should be larger than the cathodic area.

The passivity of stainless steel is the result of a corrosion-resistant oxide film on the surface. In most material environments, it will remain in the passive state and tend to be cathodic to ordinary iron or steel. When

TABLE 3.1

Galvanic Series of Metals and Alloys in Seawater

Active Corroded End			
	Magnesium	Copper	
	Magnesium alloys	Aluminum bronze	
	Zinc	Composition G bronze	
	Beryllium	90–10 nickel	
	Alchid 3S	70–30 copper-nickel; low iron	
	Aluminum 3S	70–30 copper nickel; high iron	
	Aluminum 61S	Nickel	
	Aluminum 63S	Inconel, nickel-chromium	
	Aluminum 52	alloy 600 (passive)	
	Low-carbon steel	Silver	
	Alloy carbon steel	Type 410 (passive)	
	Cast iron	Type 430 (passive)	
	Type 302, 303, 321, 347, 310, 416 (active)	Type 304 (passive)	
		Type 316, (317 (passive)	
	Type 430 (active)	Monel, nickel-copper	
	Type 304 (active)	alloy 400	
	Type 316 (active)	Hastelloy alloy C	
	Ni-Resist	Titanium	
	Muntz metal	Zirconium	
	Hastelloy B (active)	Graphite	
	Yellow brass	Gold	
	Admiralty brass	Platinum	
	Aluminum brass		
	Red brass		
			Noble protected end

chloride concentrations are high, such as in seawater or in reducing solutions, a change to the active state will usually take place. Oxygen starvation also causes a change to the active state. This occurs when there is no free access to oxygen, such as in crevices and beneath contamination of partially fouled surfaces.

Differences in soil concentrations, such as moisture content and resistivity, can be responsible for creating anodic and cathodic areas. Where there is a difference in concentrations of oxygen in the water or in moist soils in contact with metal at different areas, cathodes will develop at high oxygen concentrations, and anodes will develop at points of low oxygen concentration. Strained portions of metals tend to be anodic and unstrained portions tend to be cathodic.

Sometimes, nonmetallic conductors can act as cathodes in galvanic couples. Both carbon brick in vessels made of common structural metals and impervious graphite in heat exchanger applications are examples. Conductive films, such as mill-scale (Fe_2O_3) or iron sulfide on steel, or lead sulfate on lead, are cathodic to the base metal or to some metallic components in their contact.

The galvanic series is an arrangement of metals and alloys according to their actual measured corrosion potentials in a given environment.

It should be noted that alloys have been included in the series as has graphite, a nonmetallic of electrochemical interest. Note that different positions in the series are occupied by active-passive metals and alloys.

It is common practice to predict galvanic behavior in various environments based on the galvanic series in seawater. However, caution must be exercised. Changes in temperature and electrolyte composition can change the electrode potential, thereby causing a change in position in the galvanic series.

Ideally, there should be a galvanic series for each environment, which would require an infinite number of tests, which would not be practicable.

3.3.3 Preventive Measures

Preventive measures that may be taken include:

1. When joining two dissimilar metals together, galvanic corrosion can be prevented by insulating the two materials from each other. For example, when bolting flanges of dissimilar metals together, plastic washers can be used to separate the two metals.
2. Do not couple metals that are far apart in the galvanic series.
3. Avoid small anode–large cathode combinations. Fasteners should be cathodic to the parts being fastened.
4. Any coating being applied should be applied to the cathodic member and not to the anodic member. This is to prevent an unfavorable anode/cathode ratio should any discontinuity in the coating occur.
5. Anodic parts may be made thicker to provide a longer life.
6. A sacrificial metal may be installed that would be anodic to both metals.

3.4 Crevice Corrosion

Crevice corrosion is a localized type of corrosion occurring within or adjacent to narrow gaps or openings formed by metal-to-metal or metal-to-nonmetal contact. It results from local differences in oxygen concentrations, associated

deposits on a metal surface, gaskets, lap joints, or crevices under a bolt or around rivet heads where small amounts of liquid can collect and become stagnant.

Crevice corrosion may take place on any metal and in any corrosive environment. However, metals such as aluminum and stainless steels that depend on their surface oxide film for corrosion resistance are particularly prone to crevice corrosion, especially in environments such as seawater that contains chloride ions.

The gap defining a crevice is usually large enough for the entrapment of a liquid but too small to permit flow of liquid. The width is on the order of a few thousandths of an inch, but not exceeding 3.18 mm.

The material responsible for forming the crevice need not be metallic. Wood, plastic, rubber, glass, concrete, asbestos, wax, and living organisms have all been reported to have caused crevice corrosion. After the attack begins within the crevice, its progress is very rapid. It is frequently more intense in chloride environments.

The critical corrosion temperature of an alloy is the temperature at which crevice corrosion is first observed when immersed in a ferric chloride solution. Table 3.2 lists the critical crevice corrosion temperatures of several alloys in 10% ferric chloride solution.

In a corrosive environment, the areas inside the crevice and outside the crevice undergo corrosion in the same manner. In a neutral chloride solution, the anodic dissolution is supported by the cathodic reduction of oxygen:



TABLE 3.2

Critical Crevice Corrosion
Temperatures in 10% Ferric
Chloride Solution

Alloy	Temperature (°F/°C)
Type 316	27/-3
Alloy 825	27/-3
Type 317	36/2
Alloy 904L	59/15
Alloy 220S	68/20
E-Brite	70/21
Alloy G	86/30
Alloy 625	100/38
A1-6XN	100/38
Alloy 276	130/55

Source: From Reference 2.

As the reactions proceed, the dissolved oxygen in the small volume of stagnated solution inside the crevice is consumed. However, this does not prevent the dissolution reaction inside the crevice because the electrons reach outside the crevice through the metal, where there is plenty of oxygen available for reduction. A concentration cell (differential aeration) is set up between the crevice area and the area outside the crevice.

When chloride ions are present, the situation is further aggravated. The accumulated cations inside the crevice attract the negatively charged chloride ions from the bulk solution. Hydroxide anions also migrate but they are less mobile than the chloride ions. The metal chloride formed hydrolyzes to produce metal hydroxide and hydrochloric acid:

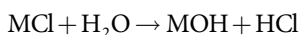

The nascent hydrochloric acid destroys the passive film and accelerates the rate of dissolution of the metal inside the crevice. The cathodic reduction remains restricted to the areas outside the crevice that remain cathodically protected.

3.4.1 Preventive Measures

Prevention can be accomplished by proper design and operating procedures, including:

1. Proper design, avoiding crevices, will control crevice corrosion. If lap joints are used the crevices caused by such joints should be closed by either welding or suitable caulking compound designed to prevent corrosion. Nonabsorbent gasketing should be used at flanged joints, while fully penetrated butt-welded joints are preferable to threaded, bolted, or riveted joints.
2. Porous gaskets should be avoided. Use an impervious gasket material. During long shutdown periods, wet packing materials should be removed.
3. The use of alloys resistant to crevice corrosion should be considered. The resistance of stainless steel to crevice corrosion can be improved by increasing the chromium, nickel, molybdenum, and nitrogen content. For example, type 316 stainless steel containing 2 to 3% molybdenum is fairly resistant, whereas nickel alloys are more resistant than stainless steels.
4. Reduction of crevice corrosion can be accomplished, when possible, by reducing the temperature, decreasing the chloride content, or decreasing the acidity.

5. The gaps along the periphery of tanks mounted on masonry platforms should be closed with tar or bitumen to avoid seepage of rainwater. Vessels and tanks should be designed to provide complete drainage, thereby preventing the buildup of solid deposits in the bottom.
6. Regular inspections and removal of deposits should be scheduled.

3.5 Pitting Corrosion

Pitting corrosion is in itself a corrosion mechanism but is also a form of corrosion often associated with other types of corrosion mechanisms. It is characterized by a highly localized loss of metal. In the extreme case, it appears as a deep, tiny hole in an otherwise unaffected surface. The initiation of a pit is associated with the breakdown of the protective film on the metal surface.

The depth of a pit eventually leads to a through penetration or a massive undercut of the thickness of a metal part. The width of the pit may increase with time but not to the extent to which the depth increases. Most often, the pit opening remains covered with the corrosion product, making it difficult to detect during inspection. This, along with a negligible loss in weight or absence of apparent reduction in the overall wall thickness, gives little evidence as to the extent of the damage. Pitting may result in the perforation of a water pipe, making it unusable even though a relatively small percentage of the total metal has been lost due to rusting.

Pitting can also cause structural failure from localized weakening effects even though there is considerable sound material remaining. Pits may also assist in brittle failure, fatigue failure, environment-assisted cracking like stress corrosion cracking (SCC), and corrosion fatigue by providing sites of stress concentration.

The main factor that causes and accelerates pitting is electrical contact between dissimilar metals, or between what are termed “concentration cells” (areas of the same metal where oxygen or conductive salt concentrations in water differ). These couples cause a difference of potential that results in an electric current flowing through the water or across the moist steel, from the metallic anode to the nearby cathode. The cathode may be brass or copper, mill scale, or any other portion of the metal surface that is cathodic to the more active metal areas. However, when the anodic area is relatively large compared with the cathodic area, the damage is spread out and is usually negligible. When the anodic area is relatively small, the metal loss is concentrated and may be serious. For example, it can be expected when large areas of the surface are generally covered by mill scale, applied coatings, or deposits of various kinds, but breaks exist in the continuity of the protective

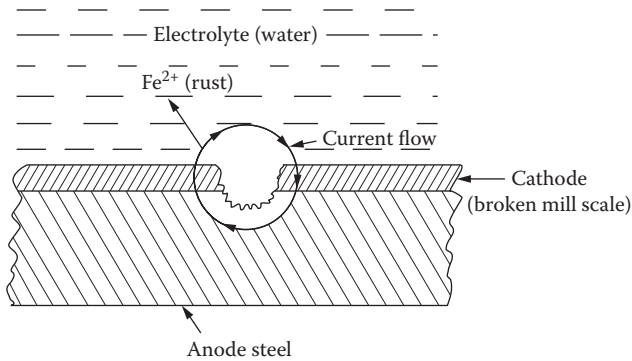
**FIGURE 3.2**

Formation of pit from break in mill scale. (Source: From Reference 5.)

material. Pitting may also develop on bare, clean metal surfaces because of irregularities in the physical or chemical structure of the metal. Localized dissimilar soil conditions at the surface of the steel can also create conditions that promote pitting. Figure 3.2 shows how a pit forms when a break in mill scale occurs.

If an appreciable attack is confined to a small area of metal acting as an anode, the developed pits are defined as deep. If the area of attack is relatively large, the pits are called shallow. The ratio of deepest metal penetration to average metal penetration, as determined by weight loss of the specimen, is known as the pitting factor. A pitting factor of 1 represents uniform corrosion. Pitting corrosion is characterized by the following features:

1. The attack is spread over small discrete areas. Pits are sometimes isolated and sometimes close together, giving the area of attack a rough appearance.
2. Pits usually initiate on the upper surface of the horizontally placed parts and grow in the direction of gravity.
3. Pitting usually requires an extended initiation period before visible pits appear.
4. Conditions prevailing inside the pit make it self-propagating without any external stimulus. Once initiated, the pit grows at an ever-increasing rate.
5. Stagnant solution conditions lead to pitting.
6. Stainless steels, aluminum, and their alloys are particularly susceptible to pitting. Carbon steels are more resistant to pitting than stainless steels. Most failures of stainless steels occur in neutral-to-acid chloride solutions. Aluminum and carbon steels pit in alkaline chloride solutions.

- Most pitting is associated with halide ions (chlorides, bromides) and hypochlorites, which are particularly aggressive. Cupric, ferric, and mercuric halides are extremely aggressive because their cations are cathodically reduced and sustain attack.

Performance in the area of pitting and crevice corrosion is often measured using critical pitting temperature (CPT), critical crevice temperature (CCT), and pitting resistance equivalent number (PREN). As a general rule, the higher the PREN, the better the resistance. The PREN is determined by the chromium, molybdenum, and nitrogen contents:

$$\text{PREN} = \% \text{Cr} + 3.3 (\% \text{Mo}) + 30 (\% \text{N})$$

Table 3.3 lists the PREN values for various austenitic stainless steels.

The CPT of an alloy is the temperature of a solution at which pitting is first observed. These temperatures are usually determined in ferric chloride (10% $\text{FeCl}_3 \cdot 6\text{H}_2\text{O}$) and acidic mixtures of chlorides and sulfates.

3.5.1 Preventive Measures

Preventive measures that may be taken:

- Solution aggressiveness can be reduced by eliminating chlorides or by decreasing their concentration.
- Stagnation of the solution should be avoided.
- Addition of passivating inhibitors helps in reducing or eliminating pitting attack. However, it is important that inhibitors are used in sufficient concentration to ensure complete passivation. Incomplete passivation can cause increased attack.

TABLE 3.3
Pitting Resistance Equivalent Numbers

Alloy	PREN	Alloy	PREN
654	63.09	316LN	31.08
31	54.45	316	27.90
25-6MO	47.45	20Cb3	27.26
A1-6XN	46.96	348	25.60
20MO-6	42.81	347	19.0
317LN	39.60	331	19.0
904L	36.51	304N	18.3
20Mo-4	36.20	304	18.0
317	33.2		

4. The use of a sacrificial anode, which has been found to prevent pitting in marine operations, or cathodic protection by means of an impressed current, is another possible preventative measure. In more aggressive solutions, this may not provide protection.
5. The most practical solution, if economically feasible, would be to use a metal or alloy having a higher resistance to pitting. Table 3.3 can be used as a guide. Titanium and its alloys provide excellent pitting resistance in most aggressive media, such as those containing ferric or cupric chloride. In seawater, type 316 stainless steel is far superior to type 304 stainless steel. Going up the scale, nickel alloys such as Hastelloy® are even better.

3.6 Erosion Corrosion

The term “erosion” applies to deterioration due to mechanical force. When the factors contributing to erosion accelerate the rate of corrosion of a metal, the attack is called *erosion corrosion*. Erosion corrosion is usually caused by an aqueous or gaseous corrodent flowing over the metal surface or impinging upon it. The mechanical deterioration may be aggravated by the presence of a corrodent, as in the case of fretting or corrosive wear.

The attack takes the form of grooves, that is, scooped out rounded areas, horseshoe-shaped depressions, gullies or waves, all of which often show directionality. At times, attack may be an assembly of pits. Ultimate perforation due to thinning or progressive pits, and rupture due to failure of the thinned wall to resist the internal fluid pressure are common. All equipment exposed to flowing fluid is subject to erosion corrosion, but piping systems and heat exchangers are the most commonly affected.

Erosion corrosion is affected by velocity, turbulence, impingement, the presence of suspended solids, temperature, and prevailing cavitation conditions. Acceleration of the attack is due to the destruction or removal of the protective film by mechanical forces, thus exposing fresh metal surfaces that are anodic to the uneroded neighboring film. A hard, dense, adhering film, such as on stainless steel, is more resistant than a soft brittle film, such as that on lead. The nature of the protective film depends largely on the corrosive itself.

In most metals and alloys, corrosion rates increase with increased velocity, but a marked increase is experienced only when a critical velocity is reached.

Turbulence is caused when the liquid flows from a larger area to a small diameter pipe, as in the inlet ends of tubing in heat exchangers. Internal deposits in the pipes, or any obstruction to the flow inside a pipe by foreign bodies, such as a carried-in pebble, can also cause turbulence.

Impingement (i.e., direct contact of the corrodent on the metal surface) occurs at bends, elbows, and tees in a piping system and causes intense attack. Impingement is also encountered on the surface of impellers and turbines, in areas in front of inlet pipes in tanks, and in many other situations. The attack appears as horseshoe-shaped pits with a deep undercut and the end pointing in the direction of flow.

An additional subset of erosion corrosion is the case of cavitation that is prevalent in pump impellers. This form of attack is caused by the formation and collapse of tiny vapor bubbles near a metallic surface in the presence of a corrodent. The protective film is again damaged, in this case by the high pressure caused by the collapse of the bubbles.

When two metal surfaces are in contact and experience a very slight relative motion that results in damage to one or the other surfaces, *fretting corrosion*, a special form of erosion corrosion, takes place. The movement causes mechanical damage to the protective film. This can lead to erosion corrosion if a corrodent is present. This corrosion usually takes the form of pitting attack. Attack is further aggravated at higher temperatures and with solutions containing solids in suspension. Steam carrying water condensate droplets provides an aggressive medium for corrosion of steel and cast iron piping. The impingement of water droplets at the return bends destroys the protective oxide film and accelerates attack on the substrate.

Soft and low-strength metals, such as copper, aluminum, and lead, are especially susceptible to erosion corrosion, as are the metals and alloys that are inherently less corrosion resistant, such as carbon steels.

Stainless steels, of all grades, are generally resistant to erosion corrosion. The addition of nickel, chromium, or molybdenum further improves their performance. Stainless steels and chromium steels are resistant as the result of their tenacious surface films.

As a rule, solid solution alloys provide better resistance than alloys hardened by heat treatment because the latter are heterogeneous in nature.

Cast iron usually performs better than steel. Alloy cast irons containing nickel and chromium exhibit better performance. Duriron, containing 14.5% silicon, gives excellent performance under severe corrosive conditions.

3.6.1 Preventive Measures

Changing the design can minimize or completely eliminate erosion corrosion. For example, the shape or geometry of the component has an effect. Increasing wall thickness at the affected areas will extend the life of the component. Other factors such as reducing velocity, reducing or eliminating turbulence, and the proper design of the piping system or heat exchangers will also reduce or eliminate erosion corrosion. Selecting a harder material of construction is another alternative.

Impingement attack can be avoided by increasing pipe diameters, and installing baffles will restrict the impact of the fluid.

Cavitation damage can be minimized by the proper choice of materials. Titanium alloys, austenitic stainless steels, nickel-chromium and nickel-chromium-molybdenum alloys can be used in extremely severe conditions. Hard facing of the surface with a resistant alloy is also beneficial. Cavitation can also be combated by applying a resilient coating of rubber or other resilient elastomeric material to the surface. The softer coating reflects the shock waves and reduces the damage on metallic parts.

3.7 Stress Corrosion Cracking (SCC)

SCC is defined as the delayed failure of alloys by cracking when exposed to certain environments in the presence of static tensile stress. The importance of a conjoint action of corrosion and stress is reflected in the definition; an alternate application of stress and corrosive environment will not produce SCC. The stress level at which failure occurs is well below the stress required for a mechanical failure in the absence of corrosion. The minimum stress below which SCC will occur is called the “threshold stress,” but this may be as low as 10% of the yield stress in some systems. Corrosion alone in the absence of stress does not cause SCC.

SCC occurs at points of stress. Usually, the metal or alloy is free of corrosion over most of its surface, yet fine cracks penetrate through the surface at the points of stress. Depending on the alloy system and corrodent combination, the cracking can be intergranular or transgranular. The rate of propagation can vary greatly and is affected by stress levels, temperature, and concentration of the corrodent. This type of attack takes place in certain media. All metals are potentially subject to SCC. The conditions necessary for stress corrosion are:

1. Suitable environment
2. Tensile stress
3. Sensitive metal
4. Appropriate temperature and pH values

The first report of SCC took place in the beginning of the twentieth century. It was reported as “season cracking” of brass cartridge cases in ammonia-bearing atmospheres. Another classic example of SCC reported in the early part of the twentieth century was that of “caustic embrittlement” of riveted boiler plates in the early steam-driven locomotives. In this case, the cause of SCC was the residual stress developed during the riveting operations and the presence of concentrated sodium hydroxide in the areas of the residual stress.

Over the years, many alloy–environment combinations have been discovered that have led to SCC. Practically all alloys used for engineering purposes are subject to SCC. However, all alloys are not susceptible to SCC in all environments. Table 3.4 provides a list of alloy–environment combinations that exhibit stress corrosion cracking. However, note that this list is not all-

TABLE 3.4

Alloy–Environment Combinations Causing Stress Corrosion Cracking

Alloy	Environment
Aluminum alloys	Air with water Potable waters Seawater, NaCl solutions NaCl-H ₂ O ₂ solutions
Carbon steels	Caustic NaOH solutions HCN solutions Calcium, ammonium, and sodium nitrate solutions Acidified H ₂ S solutions Anhydrous liquid ammonia Carbonate/bicarbonate CO/CO ₂ solutions Seawater
Copper alloys	Ammoniacal solutions Amines Nitrates
Nickel alloys	Caustic alkaline solutions High-temperature chloride solutions High-purity steam Hydrofluoric acid Acidic fluoride solutions
<i>Stainless Steels</i>	
Austenitic	Hot acid chloride solutions NaCl-H ₂ O ₂ solutions NaOH-H ₂ S solutions Seawater Concentrated caustic solutions Neutral halides, Br, I, F ⁻
Austenitic (sensitized)	Polythionic acids Sulfurous acid Pressurized hot water containing 2 ppm dissolved oxygen
Ferric	H ₂ S, NH ₄ Cl, NH ₄ NO ₃ , hypochlorite solutions
Martensitic	Caustic NaOH solutions
Titanium alloys	Red-fuming nitric acid Hot salts, molten salts N ₂ O ₄ Methanol/halide

Source: From Reference 3.

inclusive; newer combinations and newer environments that cause SCC in a particular alloy are constantly being discovered and are being added to the list.

An ammonia environment can induce SCC in copper-containing alloys whereas with low-alloy austenitic stainless steels, a chloride-containing environment is necessary. It is not necessary to have a high concentration of corrodent to cause SCC. A solution containing only a few parts per million of the critical ion is all that is necessary. Temperature and pH are also factors. There is usually a threshold temperature below which SCC will not take place and a minimum or maximum pH value before cracking will start.

The alloy content of stainless steel, particularly nickel, determines the sensitivity of the metal to SCC. Ferritic stainless steel, which is nickel-free, and the high-nickel alloys are not subject to SCC. An alloy with a nickel content greater than 30% is immune to SCC. The most common grades of stainless steel (304, 304L, 316, 316L, 321, 347, 303, and 301) have nickel contents in the range of 7 to 10% and are the most susceptible to SCC.

Examples of SCC include the cracking of austenitic stainless steels in the presence of chlorides, caustic embrittlement cracking of steel in caustic solutions, cracking of cold-formed brass in ammonia environments, and the cracking of monel in hydrofluorosilicic acid.

In severe combinations such as type 304 stainless steel in a boiling magnesium chloride solution, extensive cracking can be generated in a matter of hours.

Unalloyed titanium with an oxygen content of less than 2% (ASTM grades 1 and 2) is susceptible to SCC in absolute methanol and higher alcohols, certain liquid metals such as cadmium and possibly mercury, red-fuming nitric acid, and nitrogen tetroxide. The presence of halides in the alcohol accelerates cracking tendencies. The presence of water (<2%) tends to inhibit SCC in alcohols and red-fuming nitric acid. Titanium is not recommended for use in these environments under any anhydrous conditions.

Fortunately, in most industrial applications, the progress of SCC is much slower. However, because of the nature of the cracking, it is difficult to detect until extensive corrosion has developed, which can lead to unexpected failure.

Normally, SCC will not occur if the part is in compression. Fatigue is triggered by a tensile stress that must approach the yield stress of the material. The stresses may be induced by faulty installation or they may be residual stresses from welding, straightening, bending, or accidental denting of the equipment. Pits, which act as stress concentration sites, will often initiate SCC.

Tensile stresses can lead to other corrosion processes, such as the simple mechanical fatigue process. Corrosion fatigue is difficult to differentiate from simple mechanical fatigue but it is recognized as a factor when the environment is believed to have accelerated the normal fatigue process. Such systems can also have the effect of lowering the endurance limit so that fatigue will occur at a stress level below which it would be normally expected.

It is important that any stresses that may have been induced during the fabrication be removed by an appropriate stress-relief operation. Care should

be taken so as not to induce a stress as a result of the installation. The design should also avoid stagnant areas that could lead to pitting and the initiation of stress concentration sites.

Operations such as cold-forming, rolling, deep drawing, thermal processing like welding, solidification of casting with large differences in section thickness, or severe quenching operations are all capable of producing residual stresses of as high as 70% of the yield strength. Design stress raisers may aggravate the situation. These stress raisers may be notches related to the design, inclusions, welding strikes, rough machining marks, etc. They may also result from localized corrosion attack such as pitting, intergranular corrosion, or selective leaching.

Thermal stresses of very high magnitude may be caused by exposing the metal parts to high and low temperatures, which results in nonuniform heating rates and sharp thermal gradients. This is often found in heat exchangers. When the environment on the cold side of the heat exchanger is conducive to stress corrosion, cracking will be produced by these thermal stresses.

Corrosion products that accumulate in fissures or tightly joined parts may produce a wedging action with sufficiently high stress to cause SCC.

Because stress corrosion environments usually are relatively mildly corrosive from the viewpoint of general corrosion, the surface of a stress-corroded component will exhibit only faint signs of corrosion, while fine cracks penetrate deeply into the part. The cracks proceed in a direction perpendicular to the stresses and can be either transgranular or intergranular.

One type of cracking is usually more prevalent in a specific alloy. For example, austenitic stainless steels crack transgranularly in boiling magnesium chloride solution while carbon steels crack intergranularly in nitrate solutions.

Depending on the environment, cold work, metallurgical conditions, or alloy composition, it is possible to have a transition from one type of cracking to the other.

Stress corrosion cracks have the appearance of a brittle mechanical fracture, which is readily seen in a scanning electron microscope, whether transgranular or intergranular.

3.7.1 Preventive Measures

The most effective measure is to remove or prevent the application of tensile stresses. By proper design and installation techniques, many tensile stresses can be avoided.

When tensile stresses are present as a result of manufacturing/fabrication procedures, these stresses should be removed. Removal can be accomplished by annealing or by shot peening. When annealing is not practical, as in the case of some stainless steels that sensitize and become susceptible to intergranular attack, shot peening may be employed. However, shot peening

must be applied uniformly; it will not be effective if pitting occurs on the compressive layer.

The use of inhibitors may reduce or even eliminate SCC by moving the corrosion potential outside the range of cracking. For example, the addition of a small amount of nitrates to concentrated NaOH prevents SCC of steel. Substances such as H_3PO_4 , Na_2O_4 , and $\text{CO}(\text{NH}_2)_2$ retard or prevent the cracking of iron in nitrates.

Another option, when practical and economically feasible, is to select a different material of construction — one that is not susceptible to SCC in the particular environment.

3.8 Biological Corrosion

Biologically influenced corrosion refers to the degradation of metals caused by the activity of living organisms. Contributing to the corrosion are both micro- and macroorganisms in a variety of environments, including domestic and industrial fresh waters, soils, groundwater, seawater, natural petroleum products, and oil-emulsion cutting fluids. Biologically influenced corrosion does not represent a special form of corrosion but rather the aggravation of corrosion under environmental conditions in which corrosion rates are expected to be low.

Corrosive conditions can be developed by living microorganisms as a result of their influence on anodic and cathodic reactions. The metabolic activity can directly or indirectly cause deterioration of a metal by the corrosion process; this activity can:

1. Produce a corrosive environment
2. Create electrolytic cells on the metal surface
3. Alter the resistance of surface films
4. Have an influence on the rate of anodic or cathodic reactions
5. Alter the environmental composition

Because this form of corrosion gives the appearance of pitting, it is first necessary to diagnose the presence of bacteria. This is also referred to as microbial-induced corrosion (MIC).

The term “microorganism” covers a wide variety of life forms, including bacteria, blue-green cyanobacteria, algae, lichens, fungi, and protozoa. All microorganisms may be involved in the biodeterioration of metals. Pure cultures never occur under natural conditions; rather, mixed cultures prevail. Of the mixed cultures, only a few actually become involved in the process of corrosion. The other organisms support the active ones by adjusting the environmental conditions to support their growth. For example, in

the case of metal corrosion caused by sulfate-reducing bacteria (SRB), the accompanying organisms remove oxygen and produce simple carbon compounds, such as acetic acid and/or lactic acid, as nutrients for SRB.

Bacteria are the smallest living organisms on this planet. Some can only live with, and others only without oxygen. Some can adapt to changing conditions and live with either, aerobically or anaerobically. There is wide diversity with regard to their metabolisms. They are classified as to their source of metabolic energy as follows:

Energy Source	Classification
Light	Phototrophs
Chemical reactors	Chemotrophs
Inorganic hydrogen donators	Lithotrophs
Organic hydrogen donators	Organotrophs
Carbon dioxide (cell source)	Autotrophs
Organic molecules (cell source)	Heterotrophs

These six terms may be combined to easily describe the nutritional requirements of bacteria. For example, if energy is derived from inorganic hydrogen donators and biomass are derived from organic molecules, they are microtrophs (chemo-litho-organotrophs).

An important feature of microbial life is the ability to degrade any naturally occurring compound. Exceptions to the rule are a few manmade materials such as highly polymerized and halogenated compounds.

In addition to energy and carbon sources, nitrogen, phosphorus, and trace elements are needed by microorganisms. Nitrogen compounds may be inorganic ammonium nitrate as well as organically bound nitrogen (e.g., amino acids, nucleotides). With the help of an enzyme called nitrogenase, bacteria are able to fix nitrogen from atmospheric nitrogen, producing ammonia that is incorporated into cell constituents.

Phosphorus is taken in as inorganic phosphate or as organically bound phosphoroxylated compounds such as phosphorus-containing sugars and liquids. Phosphorus, in the form of adenosine triphosphate (ATP), is the main energy-storing compound.

For many of the metabolic purposes, trace elements are needed. Cobalt aids in the transfer of methyl groups from/to organic or inorganic molecules. Vitamin B₁₂, cobalamin, is involved in the methylation of heavy metals such as mercury. Iron, as Fe²⁺ or Fe³⁺, is required for the electron transport system, where it acts as an oxidizable/reducible central atom in cytochrome of nonhemo-iron-sulfur proteins. Magnesium acts in a similar manner in the chlorophyll molecule. Copper is an essential part of a cytochrome that, at the terminal end of the electron transport system, is responsible for the reduction of oxygen to water.

Because life cannot exist without water, water is an essential requirement for microbial life and growth. Requirements differ as to the amount of water needed. A solid material is surrounded by three types of water: hygroscopic, pellicular, and gravitational. Only gravitational and pellicular water are biologically available and can be used by microorganisms. The biologically available water is usually measured as the water activity:

$$a_w = \frac{V_s}{P_w}$$

where V_s is the vapor pressure of the solution and P_w is the vapor pressure of pure water at the same temperature. Most bacteria require an a_w value in excess of 0.90.

Hydrogen ion concentration is another important factor affecting growth. Microorganisms are classified as to their ability to grow under acidic, neutral, or alkaline conditions, being given such titles as acidophiles or alkalophiles. Most microorganisms thrive in the neutral pH range of 6 to 8.

Microbial growth is also affected by redox potential. Under standard conditions, hydrogen is assumed to have a redox potential of -42 nV and oxygen has a redox potential of 820 nV. Metabolism can take place within that range.

Available oxygen is another factor influencing microbial growth. Microbial growth is possible under aerated as well as under totally oxygen-free conditions.

Those organisms living with the amount of oxygen contained in the air are called aerobes, whereas those that perform their metabolism without any trace of oxygen are called anaerobes. The latter are able to use bound oxygen (sulfate, carbon dioxide) or to ferment oxygen compounds.

Temperature is another important factor affecting microbial growth. Microbial life is possible within the range of 21 to 230°F (-5 to 110°C). Microorganisms are also classified as to the temperature range in which they thrive, as in the following table:

Microorganism	Temperature Range	
	$^\circ\text{C}$	$^\circ\text{F}$
Psychrophiles	-5 to 20	21 to 28
Psychotrophs	55 to 30	41 to 86
Mesophiles	20 to 45	69 to 110
Moderate thermophiles	40 to 55	104 to 131
Thermophiles	55 to 85	131 to 185
Extreme thermophiles	up to 110	up to 230

Most organisms live in the mesophilic range of 69 to 110°F (20 to 45°C), which corresponds to the usual temperature range of the Earth.

MIC may occur for metallic materials in many industrial applications. It has been reported in the following industrial applications:

Industry	Location of MIC
Chemical processing	Pipelines, stainless steel tanks, flanged joints, welded areas, after hydro-testing with natural river or well water
Nuclear power generating	Copper-nickel, brass, stainless steel, and aluminum-bronze cooling water pipes, carbon and stainless steel piping and tanks
Underground pipeline	Water-saturated clay-type soils of near-neutral pH with decaying organic matter and a source of self-reducing bacteria
Metalworking	Increased wear from breakdown of machine oils and emulsions
On-shore and offshore oil and gas plants	Mothballed and flooded systems, oil- and gas-handling systems, particularly in environments soured by SRB-produced sulfides
Water treatment, sewage handling and treatment	Heat exchangers and piping, concrete and concrete-reinforced structures
Highway maintenance	Culvert piping
Aviation	Aluminum integral wiring, tanks, including fuel storage tanks

The methods by which microorganisms increase the rate of corrosion of metals and/or their susceptibility to localized corrosion in an aqueous environment are:

1. *Production of metabolites.* Bacteria may produce organic acids, inorganic acids, sulfides, and ammonia, all of which may be corrosive to metallic materials.
2. *Destruction of protective layers.* Organic coatings may be attacked by various microorganisms, leading to the corrosion of the underlying metal.
3. *Hydrogen embrittlement.* By acting as a source of hydrogen and/or through the production of hydrogen sulfide, microorganisms may influence hydrogen embrittlement of metals.
4. *Formation of concentration cells at the metal surface and, in particular, oxygen concentration cells.* A concentration cell may be formed when a biofilm or bacterial growth develops heterogeneously on the metal surface. Some bacteria may tend to trap heavy metals such as copper and cadmium within the extracellular polymeric substance, causing the formation of ionic concentration cells. These lead to localized corrosion.

5. *Modification of corrosion inhibitors.* Certain bacteria may convert nitrite corrosion inhibitors used to protect aluminum and aluminum alloys from nitrate and ammonia.
6. *Stimulation of electrochemical reactors.* An example of this type is the evolution of cathodic hydrogen from microbially produced hydrogen sulfide.

MIC can result from:

1. Production of sulfuric acid by bacteria of the genus *Thiobacillus* through the oxidation of various inorganic sulfur compounds; the concentration of sulfuric acid may be as high as 10 to 12%
2. Production of hydrogen sulfide by sulfate-reducing bacteria
3. Production of organic acids
4. Production of nitric acid
5. Production of ammonia

As mentioned previously, macrobiological organisms are also capable of causing corrosion as well as fouling. These organisms consist of shells, mollusks, barnacles, etc. In most cases, fouling presents more of a problem than corrosion. Because these organisms remain attached to the metal surface, their accumulation on the bottom of a ship's hull increases the drag and power requirement. Such accumulations in heat exchangers impair heat transfer and fluid flow, while in pipelines they may clog the pipeline as well as impair fluid flow. Stagnation and low flow rates are conducive to biofouling.

As the organisms attach themselves to the metal, the underlying metal is sheltered from dissolved oxygen and a crevice condition is created. The metabolic by-products of these organisms are often acidic and therefore corrosive. In addition, the anaerobic conditions underneath the macroorganisms can favor the growth of anaerobic bacteria, which in turn accelerates the corrosion of the metal.

3.8.1 Preventive Measures

There are many approaches that can be used to prevent or to minimize MIC. Among the choices are:

1. Material change or modification
2. Environmental or process parameter modification
3. Use of organic coatings
4. Cathodic protection
5. Use of biocides

6. Microbiological methods

7. Physical methods

Before any remedial action can be taken, it is necessary to identify the type of bacteria involved in the corrosion. Aeration of water in a closed recirculating system reduces the activity of anaerobic bacteria. Chlorination and treatment with biocides help control populations of some bacteria, although they are not effective in all cases. Also, the bacteriocides fail to reach the areas underneath deposits where the bacteria thrive. Coating a buried structure with tar, enamel, plastic, or the like is often an effective means to preclude bacteria from the metal surface. Cathodic protection in combination with coatings can be used to prevent or arrest MIC.

During storage or after hydrotesting, water should not be allowed to stand for a long period of time. Complete drainage and drying is advised. Inhibitors may be used in stagnating water and cutting-oil fluids. Periodic cleaning of pipelines is also essential. In most affected soils, steel pipes may be replaced by plastic pipes to avoid microbiological corrosion.

In areas where macrofouling may occur, these options can reduce or prevent fouling. The application of antifouling paints is probably the most effective and widely used means of preventing biofouling in seawater. Ships and piers are coated with specially formulated paints containing compounds toxic to the organisms. Copper compounds are often used because their released copper ions poison the growth of barnacles and other marine organisms. Periodic cleaning of the surfaces of structures and the inside of pipelines helps reduce the growth of crevice sites. In closed systems, fouling can be mitigated by chlorination and periodic injection of suitable biocides, including copper compounds.

The approach to follow depends on the type of bacteria present. A technique that has gained importance, in addition to the preventive method, is that of a simulation of biogenic attack. A quick-motion effect can be produced that will allow materials to be tested for their compatibility for a specific application. To conduct the simulation properly, it is necessary that a thorough knowledge of all the processes and participating microorganisms be known. The situation may be modified under conditions that will be optimal for the microorganisms, resulting in a reduced time span for the corrosion to become detectable.

3.9 Selective Leaching

The removal of one of the components of an alloy by corrosion is termed "selective leaching." Dezincification is the term used to describe the leaching

of zinc from brass, which is the most common example of selective leaching. The less noble component of an alloy is usually the element that is removed, such as zinc in brass.

“Graphite corrosion” is the term used to describe the selective leaching of iron from gray cast iron. The process of selective leaching also takes place in other alloy systems. Table 3.5 provides information regarding other alloys that are susceptible to selective leaching.

Dezincification of brasses takes place in either localized areas on the metal (called “plug type”) or uniformly over the surface (called “layer type”). Low-zinc alloys favor plug type while layer-type attack is more prevalent in high-zinc alloys. The nature of the environment seems to have a greater effect in determining the type of attack. Uniform attack takes place in slightly acidic water, low salt content, and at room temperature. Plug-type attack is found in neutral or alkaline water, high salt content, and above room temperatures. Crevice conditions under a deposit of scale or salt tend to aggravate the condition.

TABLE 3.5

Combinations of Alloys and Environments for Selective Leaching

Alloy	Environment	Element Removed
Aluminum	Hydrofluoric acid, acid chloride solutions	Aluminum
Bronzes, brasses	Many waters	Zinc
Cupronickels	High heat flux and low water velocity (in refinery condenser tubes)	Nickel
Gray iron	Soils, many waters	Iron
Gold alloys	Nitric, chromic, and sulfuric acids, human saliva	Copper or silver
High-nickel alloys	Molten salts	Chromium, iron, molybdenum, tungsten,
Iron-chromium alloys	High-temperature oxidizing atmospheres	Chromium
Medium- and high-carbon steels	Oxidizing atmospheres, hydrogen at high temperatures	Carbon
Monel	Hydrogen and other acids	Copper in some acids, nickel in others
Nickel-molybdenum alloys	Oxygen at high temperatures	Molybdenum
Silicon bronzes	High-temperature steam, acidic solution	Silicon
Tin bronzes	Hot brine, steam	Tin

Source: From Reference 2

A plug of dezincified brass may fall out, leaving a hole; whereas a water pipe having layer-type dezincification may split open. Conditions that favor selective leaching are:

1. High temperatures
2. Stagnant solutions, especially if acidic
3. Porous inorganic scale formation

Brasses that contain 15% or less zinc are usually immune. Dezincification can be suppressed by alloying additions of tin, aluminum, arsenic, or phosphorus.

Selective leaching of aluminum takes place in aluminum bronze exposed to hydrofluoric acid or acid containing chlorides. Copper-aluminum alloys containing more than 80% aluminum are particularly susceptible. Severe leaching of tin in tin bronzes in hot brine or steam, and of silicon from silicon bronzes in high-temperature steam are other examples.

Selective leaching of iron in gray cast iron is observed in gray cast iron pipes buried in soil or manhole covers exposed to mildly corrosive waters. Iron leaches out selectively, leaving behind graphite flakes as a porous mass on the metal surface. The entire structure is weakened although there is little change in metal thickness. Being weakened, fluid pressure from within or impact from outside will result in failure. Graphite corrosion does not occur in ductile iron or malleable iron. This form of corrosion is sometimes referred to as "graphitization."

3.9.1 Preventive Measures

Preventive measures that may be taken include:

1. Use a more resistant alloy. This is the more practical approach. Red brass with less than 15% zinc is almost immune. Cupro nickels provide a better substitute in severely corrosive conditions.
2. Periodically remove scales and deposits from the inside surfaces of pipelines.
3. Remove the stagnation of corrosives, particularly acidic ones.
4. Use cathodic protection.

3.10 Hydrogen Damage

The degradation of the physical and mechanical properties resulting from the action of hydrogen is known as *hydrogen damage*. The hydrogen may be

initially present in the metal or it may accumulate through absorption. In most cases, the damage is associated with residual or applied stresses. The damage may be in the form of:

1. Loss of ductility and tensile strength
2. Sustained propagation of defects at stresses well below those required for mechanical failure
3. Internal damage due to defect formation
4. Macroscopic damage, such as internal flaking, blistering, fissuring, and cracking

Hydrogen damage has occurred in many metals and alloys. High-strength steels are particularly vulnerable, and there have been many instances of failure of oil drilling and other equipment made of high-strength steels working in "sour" oil fields as a result of hydrogen damage. All types of stainless steels, aluminum, copper, nickel, and their alloys; titanium and zirconium alloys; and refractory materials such as tungsten, niobium, vanadium, and tantalum are subject to hydrogen damage.

3.10.1 Sources of Hydrogen

Metals are capable of absorbing hydrogen from various sources. Atomic hydrogen, rather than molecular hydrogen, is considered responsible for the damage. However, atomic hydrogen may be absorbed from a molecular hydrogen gas atmosphere. Hydrogen is readily available in environments such as water, water vapor, moist air, acids, hydrocarbons, hydrogen sulfide, and various liquids and gases utilized in chemical process operations.

Hydrogen damage may be produced during several stages of equipment manufacture even before the equipment is placed into service. Hydrogen can be introduced into the lattice of the metal during welding, heat treating in hydrogen-containing furnace atmospheres, acid pickling, or electroplating operations.

Underbead cracking is an embrittlement phenomenon associated with hydrogen pick-up during welding operations. Hydrogen entry into metal results from moisture in electrode coatings, high humidity in the atmosphere, and organic contaminants on the surface of prepared joints. Upon rapid cooling of the weld, entrapped hydrogen can produce internal fissuring and other damage.

During acid pickling or electroplating, and as a result of corrosion in service, atomic hydrogen is generated on the metal surface as a cathodic reduction product that diffuses into the bulk material. When the material is stressed, the diffusion rate is particularly high. In the pickling of steel, the level of hydrogen absorption depends on both the bath temperature and the nature of the acid.

Liquids or gases containing hydrogen sulfide can embrittle certain high-strength steels. Wet hydrogen sulfide environments are considered one of the most effective in promoting hydrogen entry. In these cases, hydrogen sulfide reacts with the steel to form atomic hydrogen:

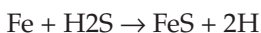

The chemisorbed sulfur particularly poisons the hydrogen recombination reaction and promotes hydrogen absorption; when the pH of the solution is above 8, a protective iron sulfide film forms on the metal surface, which protects the steel and stops the corrosion. If cyanides are present, the protective film will be destroyed. The unprotected steel corrodes rapidly and hydrogen damage results. Only a few parts per million (ppm) of hydrogen sulfide are sufficient to cause embrittlement or cracking in steel. Hydrogen stress cracking is a serious problem in petrochemical equipment used to store and handle the sour or hydrogen-sulfide-containing fuels.

Exposure to process fluids containing hydrogen, as in catalytic cracking, can result in hydrogen entry into the material. Exposure to hydrogen gas, or molecular hydrogen under high pressure and temperature, enhances hydrogen entry and induces damage in iron alloys, nickel alloys, and titanium alloys. Hydrogen gas, even at 1 atmosphere, is capable of causing cracking in high-strength steel.

Regardless of the source of the hydrogen, the effect on the metal is the same.

3.10.2 Types of Hydrogen Damage

The specific types of hydrogen damage are as follows:

1. Hydrogen embrittlement, which may be further divided as:
 - a. Loss in ductility
 - b. Hydrogen stress cracking
 - c. Hydrogen environment embrittlement
 - d. Embrittlement due to hydride formation
2. Hydrogen blistering
3. Flakes, fisheyes, and shatter cracks
4. Hydrogen attack

3.10.2.1 Hydrogen Embrittlement

3.10.2.1.1 Loss of Ductility

The entry of hydrogen into a metal results in decreases in elongation and reduction in area without the formation of any visible effects, chemical products, or cracking. The loss of ductility is only observed during slow-strain rate testing and concentrated tensile tests. Tensile strength is also affected

but there is no loss in impact strength. Consequently, impact tests cannot be used to determine whether or not embrittlement is present. The degree of loss of ductility is a function of hydrogen content of the metal, as seen in Figure 3.3. The loss of ductility is temporary and can be restored by driving the hydrogen out of the metal, by heating the metal. The rate of recovery depends on time and temperature. The higher the temperature, the shorter the time period required. However, the temperature should not exceed 598°F (315°C) because of the risk of high-temperature hydrogen attack.

3.10.2.1.2 Hydrogen Stress Cracking

Hydrogen stress cracking (HSC) refers to the brittle fracture of a normally ductile alloy under a substantial load in the presence of hydrogen. Carbon and low-alloy steels, stainless steels, nickel alloys, and aluminum alloys are susceptible to HSC. Hydrogen stress cracking is also referred to as hydrogen-induced cracking (HIC), hydrogen-assisted cracking (HAC), delayed fracture, and static fatigue. The cracking of high-strength steels in hydrogen sulfide environments, known as sulfide stress cracking, is a special case of HSC.

The cracking of embrittled metal is caused by static external stresses, transformation stresses (e.g., as a result of welding), internal stresses, cold working, and hardening. In the absence of a sharp initial crack, the hydrogen-induced fracture often starts at subsurface sites where triaxial stress is highest. If a sharp crack is present, the hydrogen cracking may start at the tip of the preexisting crack. High hydrogen concentrations ahead of the crack tip help the crack grow. A total hydrogen content as low as 0.1 to 10 ppm is sufficient to induce cracking. However, local concentrations of hydrogen are usually greater than average bulk values.

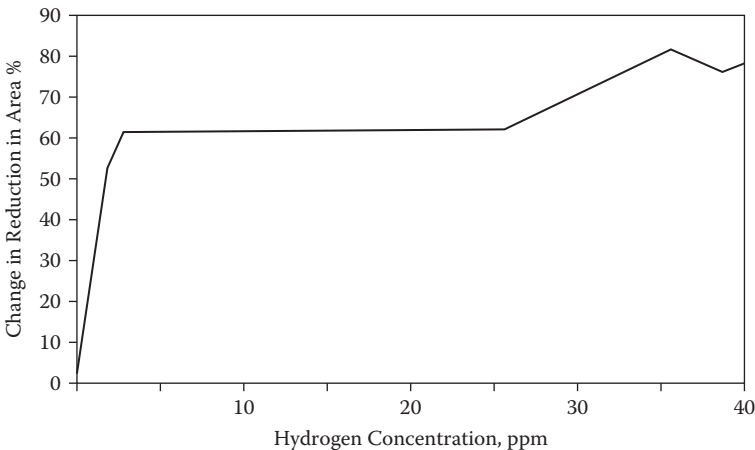

FIGURE 3.3

Loss of ductility in steel as a function of hydrogen content. (Source: From Reference 6.)

A feature of HSC is that the occurrence of the fracture is delayed, indicating that hydrogen diffusion in the metal lattice is important for the buildup of sufficient hydrogen concentrations at the regions of triaxial stresses for crack nucleation or at the crack tip for its propagation.

The susceptibility to cracking therefore depends on hydrogen gas pressure and temperature, factors that influence the diffusion process. Increasing the hydrogen pressure reduces the threshold intensity for crack propagation and increases the crack growth rate for specific stress intensity values. The threshold stress intensity and crack growth rate are a function of the specific hydrogen environment.

The susceptibility of steels to embrittlement depends to a large extent on their microstructure. A highly tempered martensitic structure with equiaxial ferritic grains and spheroidized carbides evenly distributed throughout the matrix has maximum resistance to embrittlement compared with normalized steels at equivalent strength levels. The resistance also increases with decreasing prior austenitic grain size. The presence of refined austenite is helpful because it either absorbs hydrogen or slows down crack growth. The effect of individual alloying elements on cracking susceptibility is associated with their effect on the heat treatment, microstructure, and strength of the steels. In general, carbon, phosphorus, sulfur, manganese, and chromium increase susceptibility and titanium decreases the sensitivity to HSC by decreasing the amount of hydrogen available for cracking.

The behavior of stainless steels in hydrogen environments depends on their strength levels. Because of the low hardness of ferritic stainless steels, they are extremely resistant to HSC. However, in the as-welded or cold-worked condition, they are susceptible. As a result of the higher strength of the martensitic and precipitation-hardening stainless steels, they are the most susceptible to HSC. In the annealed or highly cold-worked condition, the austenitic stainless steels are highly resistant to hydrogen cracking.

Although hydrogen stress cracking and stress corrosion cracking (SCC) are similar, there are certain distinguishing features between the two cracking processes:

1. The "specific ion" effect necessary for SCC is absent in HSC.
2. The application of cathodic potential or current, which retards or stops SCC, increases the intensity of HSC.
3. Stress corrosion cracks generally originate at the surface, while hydrogen embrittlement failures originate internally.
4. HSC usually produces sharp, singular cracks in contrast to the branching of cracks observed in SCC.

3.10.2.1.3 Hydrogen Environment Embrittlement

Hydrogen environment embrittlement is the embrittlement encountered in an essentially hydrogen-free material when it is plastically deformed or mechanically tested in gaseous hydrogen. This phenomenon has been observed in ferritic steels, nickel alloys, aluminum alloys, titanium alloys, and some metastable stainless steels in hydrogen gas, pressures ranging from 35 to 70 MPa. Embrittlement appears to be most severe at room temperature. The degree of embrittlement is maximum at low strain rates and when the gas purity is high. These characteristics are the same as those observed for HSC. Because of this, there is some question as to whether or not this should be treated as a separate class of embrittlement. However, there is one exception. While nickel alloys are very susceptible to hydrogen environment embrittlement, they are relatively unsusceptible to HSC.

3.10.2.1.4 Embrittlement due to Hydride Formation

Embrittlement and cracking of titanium, zirconium, tungsten, vanadium, tantalum, niobium, uranium, thorium, and their alloys are the result of hydride formation. Significant increases in strength and large losses in tensile ductility and impact strength are found. The brittleness is associated with the fracture of the hydride particle or its interface.

The solubility of hydrogen in these metals is 10^3 to 10^4 greater than that of iron, copper, nickel, and aluminum and increases with a decrease in temperature. The solubility tends toward saturation at low temperatures and at atmospheric pressure. The composition of the solution approaches that of a finite compound hydride or a pseudo-hydride. The crack gets stopped at the ductile matrix or continues to grow by ductile rupture of the regions between the hydrides. For some metal-hydrogen systems, the application of stress increases hydride formation. In these cases, the stress-induced hydride formation at the crack tip leads to a contained brittle fracture propagation. Titanium and zirconium form stable hydrides under ambient conditions and hydrogen is absorbed in excess of 150 ppm. Absorption of hydrogen by these metals increases rapidly if the protective oxide film normally present on the metal is damaged mechanically or by chemical reduction. Surface contaminants (e.g., iron smears) enhance hydrogen intake, and the absorption is accelerated at temperatures exceeding 160°F (70°C). Hydrogen is rapidly picked up during melting or welding, and hydride formation takes place during subsequent cooling. When sufficient hydrogen is present, the cracking is attributed to the strain-induced formation of hydrides.

3.10.2.2 Hydrogen Blistering

This type of damage is prevalent in low-strength, unhardened steels as a result of the pressure generated by the combination of atomic hydrogen to form molecular hydrogen.

Hydrogen blistering literally means the formation of surface bulges resembling a blister. The generation of hydrogen gas in voids or other defect sites located near the surface can lead to such a condition. The blisters often rupture, producing surface cracks. Internal hydrogen blistering along grain boundaries (fissures) can lead to hydrogen-induced stepwise cracking.

Killed steels are more susceptible to blistering than semi-killed steels because of greater hydrogen intake after deoxidation, but the nature and size of inclusion are overriding factors. Rimmed steels are highly susceptible because of the inherent presence of voids. Sulfur-bearing steels are also especially prone because sulfur favors hydrogen entry by acting as a cathodic poison.

Hydrogen blistering is encountered mostly during acid pickling operations. Corrosion-generated hydrogen causes blistering of steel in oil-well equipment and petrochemical storage and refining equipment.

3.10.2.3 Flakes, Fisheyes, and Shatter Cracks

Flaking refers to small internal fissures that occur in steels when cooled from temperatures on the order of 2012°F (1100°C) in hydrogen atmospheres. These are also described as fish eyes, shatter cracks, or snowflakes, and are common hydrogen damage found on forgings, weldments, and castings.

The extent of the damage depends on the time of exposure in a hydrogen-containing environment. The cracks produced are readily detectable by radiographic or ultrasonic inspection, or by visual and microscopic observation of traverse sectors.

3.10.2.4 Hydrogen Attack

Hydrogen attack is a form of damage that occurs in carbon and low-alloy steels exposed to high-pressure gas at high temperatures for extended periods of time. The damage may result in the formation of cracks and fissures or loss in strength of the alloy. This condition is prevalent above 392°F (200°C). The reaction takes place between absorbed hydrogen and the iron carbide or the carbon in solution forming hydrocarbons:

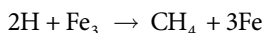

The methane produced does not dissolve in the iron lattice, and internal gas pressures lead to the formation of cracks or fissures. The strength and ductility of the steel may be lowered by the generated defects of the decarburization, which may take place internally or at the surface. In the latter case, the decarburized layer grows to increasing depths as the reaction continues. Cracking may develop in the metal under tensile stress. Temperature and hydrogen partial pressures determine the extent of the damage. Surface decarburization takes place at temperatures above 1004°F (540°C) and

internal decarburization above 342°F (200°C). Hydrogen attack can take several forms within the metal structure, depending upon the severity of the attack, stress, and the presence of inclusions in the steel.

When stress is absent, a component may undergo a general surface attack. Areas of high-stress concentrations are often the initiation point of hydrogen attack. Isolated decarburized and fissured areas are often found adjacent to weldments. Severe hydrogen attack may also result in laminations and the formation of blisters.

The stability of carbides determines the resistance of steels to hydrogen attack. Alloying with carbide-stabilizing elements such as chromium, molybdenum, vanadium, and titanium has beneficial effects. Austenitic stainless steels are not subject to hydrogen attack.

Hydrogen attack was first recognized as a major problem in the petrochemical industry in 1940 and 1949. Nelson published a classic paper on that subject, entitled "Hydrogenation Plant Steel," in the *Proceedings of the American Petroleum Institute, Refining Division*. The purpose of Nelson's study was to define practical limits for plant operations based on the operating hydrogen pressure and the temperature of service. These operating limits were based on service experience. The resulting empirical plots separated the service conditions into safe and unsafe areas. Figure 3.4 schematically represents this separation. Specific curves are developed for specific carbon steels from data received from various oil companies. Such curves defining the operating limits of these steels are referred to as Nelson curves.

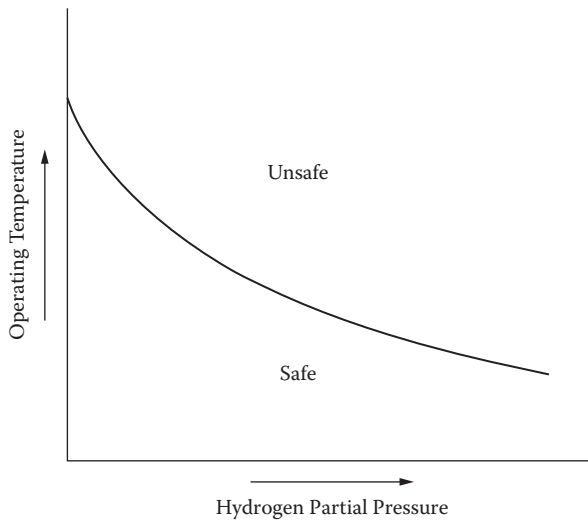

FIGURE 3.4

Schematic of safe operating limits for steel in hydrogen.

Decarburization has also been reported in nickel alloys during heat treatment at 2012°F (1100°C) in hydrogen atmospheres. Damage may also be caused in other materials as the result of hydrogen reacting at high temperature with foreign elements other than carbon in the matrix. Examples include the formation of steam in welded steels, copper, nickel, and silver by reacting with oxygen; and formation of ammonia in molybdenum by reaction with nitrogen. The disintegration of oxygen-containing copper in the presence of hydrogen is a typical example of hydrogen attack.

3.10.3 Preventive Measures

3.10.3.1 Hydrogen Blistering

Preventive measures for hydrogen blistering include:

1. *Material selection.* Corrosion-generated hydrogen blistering can be minimized using metals that are chemically resistant to the environment. Nickel-containing steels, including austenitic stainless steels and nickel-based alloys, have very low hydrogen diffusion rates and are often recommended to prevent hydrogen blistering.

On the other hand, rimmed steels contain numerous voids and are very prone to blistering and flaking. Killed steels show much less susceptibility. Silicon-killed steels are preferable to aluminum-killed steels. However, all these latter steels are subject to hydrogen blistering.

2. *Removal of poisons.* The incidence of hydrogen blistering can be greatly reduced by removing such hydrogen evolution poisons as sulfides, arsenic compounds, and phosphorus-containing ions from the environment. These poisons are very prevalent in petroleum process streams. The basic approach to reduction of corrosion-induced hydrogen blistering in catalytic cracking units is to reduce the concentration of sulfur and bisulfide ions in water condensate.
3. *Control of inclusions in steel.* Inclusion-free steels are recommended because inclusions are responsible for blistering or flaking in steel. Particularly harmful are elongated inclusions because they induce lamination. Because hydrogen evolution is reduced at low sulfur or sulfide levels, the use of low-sulfur, calcium-treated, or argon-blown steels is recommended. Treatment with synthetic slag or the addition of rare earth metals can favor the formation of less detrimental globular sulfides. On the same basis, hot-rolled steel or annealed steel is preferable to cold-rolled steel.
4. *Use of coatings.* Hydrogen blistering on the inside of steel tanks or containers can be avoided by installing a liner that is resistant to the medium and impervious to hydrogen penetration. The coatings

- may be organic, inorganic, or metallic. A rubber lining on steel, or the cladding of steel with austenitic stainless steel or nickel, are approaches that have been used.
5. *Use of inhibitors.* Inhibitors can minimize corrosion-generated hydrogen blistering because the cathodic reduction of hydrogen ions is also retarded. However, inhibitors must be used in closed-circuit systems in order to be economical.
 6. *Improvements in design.* Careful consideration must be given before modifications in design can improve the performance. For example, external support pads should not be continuously welded to the vessel itself, if blistering is expected, in order to prevent hydrogen entrapment at the interface
 7. *Proper heat-treating procedure.* The decreased solubility of hydrogen in bcc structural steel compared to the fcc structure leads to flaking and fish-eye formation in steels when they are cooled in hydrogen atmospheres from high temperatures (above 2012°F [1100°C]). The damage is aggravated if the cooling is rapid because this results in hydrogen-sensitive martensitic microstructure. A reduced cooling rate inhibits the formation of martensite and also allows hydrogen to be slowly released from the steel, thereby eliminating the damage.

3.10.3.2 Hydrogen Embrittlement

Preventive measures against hydrogen embrittlement include:

1. *Material selection.* The susceptibility of steel to hydrogen embrittlement increases with the tensile strength of the material. The threshold tensile strength is 1000 MPa, which can be lower in acidic environments. The most aggressive environment in promoting hydrogen entry is wet hydrogen sulfide. Common metals and alloys are graded according to strength level and/or heat treatment in terms of their resistance to hydrogen-induced cracking. The steels are generally restricted to a maximum hardness of 22 HRC (35 HRC for other alloys).
2. *Heat treatment.* For the same stress level, the susceptibility to hydrogen embrittlement of steels depends on their microstructure. Untempered martensite is the most susceptible phase. Quenched and tempered microstructures are more resistant than normalized and tempered. Accordingly, the heat treatment procedure may be selected.

The removal of hydrogen in steels can be carried out by heat treatment at temperatures up to 392°F (200°C), a process known as baking. In the absence of irreversible damage inside the material, a baking

treatment can restore the mechanical properties almost to normal levels.

Hydrogen can be removed from titanium, zirconium, and their alloys by annealing in vacuum.

3. *Alloying additions.* The susceptibility of steels can be reduced by alloying with strong hydride-forming elements such as titanium, molybdenum, and vanadium. The concentration of the alloying element is a factor. For example, molybdenum up to about 0.75% reduces susceptibility of AISI 4130 steel to sulfide stress cracking. Beyond this concentration, a tempering treatment at and above 932°F (500°C) leads to the precipitation of Mo_2C and the resistance to sulfide stress cracking decreases.
4. *Proper plating conditions and coatings.* Hydrogen pick-up can be controlled during plating operations by proper regulation of the bath composition and plating current; hydriding of titanium can be minimized by anodizing or thermal oxidizing treatments to increase the thickness of the protective film. Very-high-strength steels should not be subjected to cadmium plating or hot dip galvanizing.
5. *Use of inhibitors.* Pickling operations are a source of hydrogen pick-up by steel. Reducing corrosion of the base metal by the addition of inhibitors can largely decrease hydrogen pick-up.
6. *Proper welding practice.* Hydrogen embrittlement problems resulting from welding can be controlled by employing recommended welding procedures, which include proper cleaning and degreasing procedures for prepared weld joints, the use of dry electrodes, and the maintenance of dry conditions during welding. Also recommended is the use of an appropriate preheat before welding and a postweld heat treatment. To minimize hydrogen pickup of titanium, zirconium, and their alloys during welding, inert gas shielding should be employed.
7. *Oxygen addition.* The embrittlement of steel in gaseous environments can be inhibited by adding 0.4 to 0.7 vol.% oxygen. However, such additions are not effective in preventing cracking in hydrogen sulfide gas.

3.10.3.3 Hydrogen Attack

Preventive measures against hydrogen attack include:

1. *Use of Nelson curves.* The operating limits of various steels in high-temperature, high-pressure hydrogen service can be determined from the Nelson curves. These curves have been developed from data resulting from long-term refinery experience. The curves are

revised periodically by the American Petroleum Institute; therefore, the latest data should be used for the proper selection of steel.

2. *Material selection.* Steels containing 1 to 2.25% Cr and Mo are recommended for use in hydrogen atmospheres at high temperatures because carbide-forming elements such as chromium and molybdenum increase the resistance of steel to hydrogen attack. Conversely, the carbon content should be kept low because increased carbon decreases the resistance of steel to hydrogen attack.

Stainless steels, particularly austenitic stainless steels, are immune to hydrogen attack. However, atomic hydrogen will diffuse through these steels when used as a cladding material and the steel substrate will be prone to attack.

3.11 Liquid Metal Attack

Metallic components may come in contact with liquid metal during operations such as brazing, soldering, or galvanizing and in some applications such as the use of molten sodium as a coolant in fast-breeding nuclear reactors. Liquid metal may corrode the solid metal component or there may be diffusion-controlled intergranular penetration of liquid metal in the solid metal. The most drastic form of liquid metal attack is the instantaneous fracture of the solid metal in the presence of stress, a condition described as “liquid metal embrittlement” (LME). The flow behavior of the solid metal is not sufficiently affected but a significant reduction in fracture stress or strain is encountered.

The attack of solid metals by liquid metals may take place in the following forms:

1. Instantaneous failure of a solid metal under applied or residual stresses when in contact with a liquid metal
2. When a solid metal is in contact with a liquid metal at a static stress below the tensile strength of the metal, a delayed failure will occur
3. Stress-independent grain boundary penetration of a solid metal by a liquid metal
4. High-temperature corrosion of a solid metal by a liquid metal

The first two types are generally referred to as liquid metal embrittlement (LME) or liquid metal-induced embrittlement (LMIE).

3.11.1 Liquid Metal Embrittlement (LME)

The failure of a solid metal under stress in contact with a liquid metal is known as liquid metal embrittlement (LME). It is also known as liquid metal cracking. The loss of ductility of a normally ductile metal is manifested as a reduction in fracture stress, or strain, or both. Normally there is a change in fracture mode from ductile to brittle intergranular or brittle transgranular (cleavage).

The failure resulting from LME may be instantaneous or it may take place after a lapse of time following the exposure of the stressed metal to a liquid environment. The former is the classical LME while the latter is often referred to as “delayed failure” or “static fatigue.” In either case, the presence of stress is necessary. The stress may be shear, tensile, or torsional in nature — but not compressive. LME and SCC are similar in that stress must be present; however, the propagation of fracture is much faster in LME than in SCC. If sufficient time is allowed, intergranular penetration of liquid metal may render a solid metal brittle, even if stress is absent.

The elongation and reduction in area of the metal or alloy are lowered as the result of LME. The fracture stress is also reduced and, in the cases of severe embrittlement, may be less than the yield stress of the material. However, there is no change in the yield strength and strain hardening behavior of the solid metal. The liquid metal acts only to limit the total ductility before fracture or the stress at fracture if failure occurs before the normal yield point. The failure of mild steel in lithium occurs at only 2 to 3% elongation, but the lower yield point, upper yield point, and the yield point elongation remain unaffected.

As with SSC, all liquid metals do not embrittle all solid metals. For example, liquid mercury embrittles zinc but not cadmium; liquid gallium embrittles aluminum but not magnesium. Table 3.6 lists the known embrittlement combinations.

3.11.1.1 Requirements for Embrittlement

The general requirements for LME to occur in a ductile metal are as follows:

1. There must be a wetting or intimate contact of the solid metal by the liquid metal.
2. The solid metal must be stressed to the point of producing plastic deformation.
3. There must be an adequate supply of liquid metal.

The most critical condition for LME is intimate contact between the solid metal and the liquid metal. This is required in order to initiate embrittlement and guarantee the presence of liquid metal at the tip of the propagating crack to cause brittle failure. An adequate supply of liquid metal is necessary to absorb at the propagating crack tip. The total amount need not be large; a

TABLE 3.6
Summary of Embrittlement Combinations

Solid Metal	Liquid Metal																														
	Hg		Cs		Ga		Na		In		Li		Sn		Bi		Ti		Cd		Pb		Zn		Te		Sb		Cu		
	P	A	P	A	P	A	P	A	P	A	P	A	P	A	P	A	P	A	P	A	P	A	P	A	P	A	P	A	P	A	P
Sn	P	x																													
P																															
Bi	P	x																													
P																															
Cd	P	x																													
P																															
Zn	P	x																													
P																															
Mg	CA																														
Al	P	x																													
P																															
CA	x																														
Ge	P	x																													
P																															
Ag	P	x																													
P																															
CP	x																														
P																															
CA	x																														
P																															
Ni	P	x																													
P																															
CA	x																														
Fe	P	-																													
P																															
CA	x																														
Pd	P																														
P																															
CA	x																														
Ti	CA	x																													
P																															

Note: P = normally pure element, A = alloy, C = commercial, x = embrittlement combination.
Source: From Reference 4.

few monolayers of liquid atoms are all that is necessary for LME. Even a few micrograms of liquid can cause LME.

3.11.1.2 Factors Influencing LME

There are several factors that influence liquid metal embrittlement (LME), including:

- *Grain size.* The yield stress and fracture stress of a metallic material normally bear a linear relationship with the inverse square root of grain diameter. The same relationship holds true for LME. A linear decrease in fracture strength as a function of the square root of the average grain diameter has been observed for copper and iron in molten lithium, 70–30 brass in mercury, and zinc in mercury, indicating that coarse-grained materials are more susceptible to LME. The grain size dependence of LME is indicative of a reduction in cohesive strength of the material rather than an effect of the penetration or dissolution of liquid into the grain boundary.
- *Temperature.* Except for a few cases of embrittlement caused by the vapor phase, LME takes place at temperatures above the melting point of the liquid metal. In the vicinity of the melting point of the liquid metal, LME is relatively temperature insensitive. At high temperatures, brittle-to-ductile transition occurs in many systems over a temperature range, and the ductility is restored. The brittle-to-ductile transition temperature depends on the presence of a notch, grain size, and strain rate. The transition temperature increases in the presence of notches. An increase in strain rate and a decrease in grain size increase the transition temperature.
- *Strain rate.* In addition to its effect on the brittle-to-ductile transition temperature, the strain rate may be an important factor for the occurrence of LME. The effect of strain rate appears to be related to the increase in yield strength, and this corresponds to an increase in LME susceptibility.
- *Alloying.* Some metals are embrittled in their pure state (such as zinc by mercury, and aluminum by liquid gallium). On the other hand, pure iron is not embrittled by mercury, and pure copper is relatively immune in liquid mercury (coarse-grained copper is embrittled). However, iron becomes susceptible to embrittlement in mercury when alloyed with more than 2% silicon, 4% aluminum, or 8% nickel. When copper is alloyed with zinc, aluminum, silicon, or gallium, its susceptibility to LME significantly increases. The same occurs when zinc is alloyed with a small amount of copper or gold in mercury. The increase in yield strength of the metal on alloying is considered responsible for the increased susceptibility. The high-strength alloys

are more severely embrittled than low-strength alloys, based on the same metal. In iron, a nickel addition greater than 8% gives rise to martensite with coarse slip lines. In precipitation-hardening aluminum and copper alloys, maximum susceptibility to LME coincides with the peak strength of the alloys. All of these point to the generation of stress concentrations as a result of alloying.

3.11.1.3 Delayed Failure

Delayed failure refers to those failures taking place under a sustained load after a period of time. In liquid metal environments, the embrittlement and failure of some metals are time dependent.

Aluminum-copper and copper-beryllium in liquid mercury exhibit delayed failure, as does AISI 4130 steel in molten lithium. Age-hardened alloys exhibit the lowest time of fracture in the maximum hardened state. The susceptibility increases with prior strain or cold-work.

3.11.1.4 Preventive Measures

Liquid metal embrittlement can be prevented or a reduction in occurrence can be achieved by the following measures:

1. Introduction of impurity atoms in the solid metal. Examples are the addition of phosphorus to monel to reduce embrittlement in liquid mercury, or the addition of lanthanides to leaded steels.
2. In some cases the addition of a second metal to the embrittling liquid decreases the embrittlement.
3. An effective barrier between the solid metal and the liquid metal. This may be a ceramic or covalent coating.
4. Cladding with a soft, high-purity metal such as zinc alloy clad with pure zirconium to resist embrittlement in liquid cadmium.
5. Elimination of the embrittling metal.
6. Reduction in the level of applied or residual stress below the static endurance limit.

3.11.2 Corrosion by Liquid Metals

Corrosion by liquid metals becomes a matter of concern when they have to remain in contact with the solid metal over a long period of time. Because of their excellent heat transfer properties, liquid metals are being used extensively in nuclear power generation plants and in heat transfer systems making use of heat pipes containing liquid metals. Examples include liquid

sodium in fast-breeding reactors, and lithium, sodium, or sodium-potassium liquid metals as the working fluid in heat transfer systems.

Liquid metal corrosion can take place through any one or a combination of the following processes:

1. *Direct dissolution.* Direct dissolution is the release of atoms of the containment material into the molten metal. As the liquid metal becomes saturated with the dissolving metal, the dissolution reaction decreases or stops altogether. However, in a nonisothermal liquid metal system, this may not occur because of the convection from hotter to colder regions. Under this condition, the dissolved metal from the "hot leg" is carried to the "cold leg" where it gets deposited. Plugging of the coolant pipes results. Then dissolution results. The dissolution may be uniform or selective. The selective leaching may proceed to such an extent that voids are left in the steel.
2. *Corrosion product formation.* At times, the corrosion or reaction products form protective layers on the containment metal surface, thereby reducing further attack. For example, the addition of aluminum or silicon to steel helps in forming such a protective layer. The addition of zirconium to liquid bismuth or mercury has an inhibiting effect on the corrosion of steel in these liquid metals. The nitrogen present in steel forms a surface layer of ZnN, a very stable compound and an effective diffusion barrier.
3. *Elemental transfer.* Elemental transfer refers to the net transfer of impurities to or from a liquid metal. In such a case, the liquid metal atoms do not react with the atoms of the containment metal atoms. Carburization of refractory metals and of austenitic stainless steels has been observed in liquid sodium contaminated with carbon. Decarburization of iron-chromium-molybdenum steels in liquid sodium or lithium is another example of elemental transfer.
4. *Alloying.* An alloying action can be observed between the atoms of the liquid metals and the constituents of the material. Systems that form alloys or stable intermetallic compounds (nickel in molten aluminum) should be avoided.

3.12 Exfoliation

When intergranular corrosion takes place in a metal with a highly directional grain structure, it propagates internally, parallel to the surface of the metal. The corrosion product formed is about five times as voluminous as the metal consumed, and it is trapped beneath the surface. As a result, an

internal stress is produced that splits off the overlying layers of metal, hence the name exfoliation.

This is a dangerous form of corrosion because the splitting off of uncorroded metal rapidly reduces load-carrying ability. The splitting action continually exposes film-free metal, so the rate of corrosion is not self-limiting.

Exfoliation requires elongated (parallel-shaped) grains, a susceptible grain boundary condition, and a relatively severe environment. Exfoliation corrosion is mostly found in certain alloys and tempers of aluminum. The most damaging natural environments are those with high chloride ion content, such as de-icing salts or a seacoast atmosphere. The presence or absence of an applied stress has no significant effect. Coatings can delay exfoliation but the best procedure is that of resistant temper.

3.12.1 Preventive Measures

Exfoliation can be minimized by the use of extended aging cycles for aluminum-copper alloys, the use of organic and sprayed metal coatings, by avoiding graphite-bearing lubricants that act as cathodes, and by promoting an equiaxed grain structure at the surface and throughout the alloy.

3.13 Corrosion Fatigue

Corrosion fatigue is the cracking of a metal or alloy under the combined action of a corrosive environment and repeated or fluctuating stress. As in stress corrosion cracking (SCC), successive or alternate exposure to stress and corrosion does not lead to corrosion fatigue.

Metals and alloys fail by cracking when subjected to cyclic or repetitive stress, even in the absence of a corrosive medium. This is known as fatigue failure. The greater the applied stress, the fewer the number of cycles required and the shorter the time to failure. In steels and other ferrous metals, no failure occurs for an infinite number of cycles at or below a stress level called the endurance limit (also called the fatigue limit). In a corrosive medium, failure occurs at any applied stress if the number of cycles is sufficiently large. Corrosion fatigue can therefore be defined as the reduction in fatigue life of a metal in a corrosive environment. Unlike SSC, corrosion fatigue is equally prevalent in pure metals and their alloys, and is not restricted to specific environments. Any environment causing general attack in a metal or alloy is capable of causing corrosion fatigue. For steels, the minimum corrosion rate required is approximately 1 mpy.

Corrosion fatigue increases almost proportionately with the increase of general aggressiveness of the corrodent. Consequently, an increase in

temperature, a decrease in pH, or an increase in the concentration of the corrodent leads to aggravation of corrosion fatigue.

3.13.1 Preventive Measures

Corrosion fatigue can be reduced or eliminated by:

1. Lowering of the stress
2. Controlling the environment
3. Use of coatings
4. Cathodic protection
5. Shot peening

3.14 Filiform Corrosion

Metals with semipermeable coatings or films may undergo a type of corrosion resulting in numerous meandering threadlike filaments of corrosion beneath the coatings or films. The essential conditions for this form of corrosion to develop are generally high humidity (65 to 95% relative humidity at room temperature), sufficient water permeability of the film, stimulation by impurities, and the presence of film defects (mechanical damage, pores, insufficient coverage of localized areas, air bubbles, salt crystals, or dust particles).

The threadlike filaments of corrosion spread in a zig-zag manner. The filaments are 0.1 to 0.5 mm wide and grow steadily, but do not cross each other. Each filament has an active head and an inactive tail. If an advancing head meets another filament, it gets diverted and starts growing in another direction.

On steel, the tail is usually red-brown and the head is blue, indicating the presence of Fe_2O_3 or $\text{Fe}_2\text{O}_3 \cdot n\text{H}_2\text{O}$ at the tail and Fe^{2+} ions in the head as corrosion product. The growth formation is explained by the formation of a differential aeration cell. The head absorbs water from the atmosphere because of the presence of a relatively concentrated solution of ferrous salts, and hydrolysis creates an acidic environment (pH 1 to 4). Oxygen that diffuses through the film tends to accumulate more at the interface between the head and the tail. Lateral diffusion of oxygen serves to keep the main portion of the filament cathodic to the head.

Filiform corrosion has been observed on aluminum, steel, zinc, and magnesium, usually under organic coatings such as paints and lacquers. It has also been found under tin, enamel, and phosphate coatings. The attack does not damage the metal to any great extent but the coated surface loses its appearance. Filiform corrosion is always shallow in depth and causes loss

of product integrity only when it occurs on thin sheets (~0.05 mm or thinner) and foil (defined as ≤ 0.15 mm in thickness (e.g., food containers, or a foil moisture barrier on insulation board or on foil-laminated paper packaging).

On thicker painted sheet, as for aircraft and automobiles, filiform corrosion is primarily a cosmetic problem, but it causes loss of paint adhesion and can act as a site initiation of pitting or other forms of corrosion.

3.14.1 Preventive Measures

Filiform corrosion can be prevented by reducing the humidity of the environment to below 65%. Films having a very low permeability will also provide protection. Other important factors that can determine whether this form of corrosion will occur include preparation of the metal surface for coating; surface cleanliness; coating flexibility, thickness, and adherence; and the absence of voids.

References

1. Schweitzer, P.A., 2004, *Corrosion Resistance Tables, 5th edition*, Vols. 1–4, New York: Marcel Dekker.
2. Schweitzer, P.A., 2004, *Encyclopedia of Corrosion Technology, second edition*, New York: Marcel Dekker, p. 197.
3. Schweitzer, P.A., 2004, *Encyclopedia of Corrosion Technology, second edition*, New York: Marcel Dekker, p. 570–571.
4. Schweitzer, P.A., 2004, *Encyclopedia of Corrosion Technology, second edition*, New York: Marcel Dekker, p. 326.
5. Schweitzer, P.A., 2004, *Encyclopedia of Corrosion Technology, second edition*, New York: Marcel Dekker, p. 444.
6. Schweitzer, P.A., 2004, *Encyclopedia of Corrosion Technology, second edition*, New York: Marcel Dekker, p. 298.

4

Atmospheric Corrosion

Atmospheric corrosion, although not a separate form of corrosion, has received considerable attention because of the staggering costs that result. With the large number of outdoor structures such as buildings, fences, bridges, towers, automobiles, ships, and innumerable other applications exposed to the atmospheric environment, there is no wonder that so much attention has been given to the subject.

Atmospheric corrosion is a complicated electrochemical process taking place in corrosion cells consisting of base metal, metallic corrosion products, surface electrolytes, and the atmosphere. Many variables influence the corrosion characteristics of the atmosphere. Relative humidity, temperature, sulfur dioxide content, chlorine content, amount of rainfall, dust, and even the position of the exposed metal exhibit a marked influence on corrosion behavior. Geographic location is also a factor.

Because this is an electrochemical process, an electrolyte must be present on the surface of the metal for corrosion to occur. In the absence of moisture, which is the common electrolyte associated with atmospheric corrosion, metals corrode at a negligible rate. For example, carbon steel parts left in the desert remain bright and tarnish-free over long periods of time. Also, in climates where the air temperature is below the freezing point of water or of aqueous condensation on the metal surface, rusting is negligible because ice is a poor conductor and does not function effectively as an electrolyte.

Atmospheric corrosion depends not only on the moisture content present, but also on the dust content and the presence of other impurities in the air, all of which have an effect on the metal surface and the resulting corrosiveness. Air temperature can also be a factor.

All types of corrosion can take place, depending on the specific contaminants present and the materials of construction. General corrosion is the predominant form encountered because of the large quantities of steel used. However, localized forms such as pitting, intergranular attack, and stress corrosion cracking may be encountered with susceptible alloys. Because the electrolyte available consists only of a thin film of condensed or absorbed moisture, the possibility of galvanic corrosion is somewhat minimized. However, this cannot be relied upon and galvanic corrosion must always be considered in design for atmospheric exposures.

Synthetic materials as well as metals are also subject to atmospheric corrosion, depending on the specific synthetic material and the conditions of exposure. Synthetic materials, plastics and elastomers, can be subject to

degradation as a result of the action of ozone, oxygen, and sunlight. These three weathering agents can greatly affect the properties and appearance of a large number of synthetic materials. Surface cracking, discoloration of colored stock, and serious loss of tensile strength are the result of this attack. Elastomeric materials may also suffer loss of elongation and other rubber-like properties.

4.1 Atmospheric Types

Because corrosion rates are affected by local conditions, atmospheres are generally divided into the following categories:

- Rural
- Industrial
- Marine

Additional subdivisions such as urban, arctic, and tropical (wet or dry) can also be included. However, of main concern are the three major categories.

For all practical purposes, the more rural the area, with little or no heavy manufacturing operations, the less will be the problem of atmospheric corrosion.

In industrial atmospheres, all types of contamination by sulfur in the form of sulfur dioxide or hydrogen sulfide are important. The burning of fossil fuels generates a large amount of sulfur dioxide, which is converted to sulfuric and sulfurous acid in the presence of moisture. Combustion of these fossil fuels and hazardous waste products should produce only carbon dioxide, water vapor, and inert gas as combustion products. This is seldom the case. Depending on the impurities contained in the fossil fuel, the chemical composition of the hazardous waste materials incinerated, and the combustion conditions encountered, a multitude of other compounds may be formed.

In addition to the most common contaminants previously mentioned, pollutants such as hydrogen chloride, chlorine, hydrogen fluoride, and hydrogen bromide are produced as combustion products from the burning of chemical waste. When organophosphorous compounds are incinerated, corrosive phosphorus compounds are produced. Chlorides are also a product of municipal incinerators.

Road traffic and energy production lead to the formation of NO_x , which may be oxidized to HNO_3 . This reaction has a very low rate; therefore, in the vicinity of the emission, the contents of HNO_3 and nitrates are very low. The antipollution regulations that have been enacted do not prevent the escape into the atmosphere of quantities of these materials sufficiently to prevent

corrosion problems. The corrosivity of an industrial atmosphere diminishes with increasing distance from the city.

Marine environments are subject to chloride attack resulting from the deposition of crystals formed by the evaporation of spray that has been carried by the wind from the sea. The quantity of chloride deposition from marine environments is directly proportional to the distance from the shore. The closer to the shore, the greater the deposition and corrosive effect. The atmospheric test station at Kure Beach, North Carolina, shows that steels exposed 80 ft from the ocean corrode 10 to 15 times faster than steels exposed 800 ft from the ocean. In addition to these general air contaminants, there may also be specific pollutants found in a localized area. These may be emitted from a manufacturing operation on a continuous basis and can result in a much more serious corrosion problem than that caused by the presence of general atmospheric pollutants.

Because of these varying conditions, a material that is resistant to atmospheric corrosion in one area may not be suitable in another area.

To compound the problem, there is no clear line of demarcation between these atmospheric types. In many cases, there is no "pure" rural or urban area. Contamination from industrial or marine areas can find its way into these areas based on the prevailing winds and other atmospheric conditions.

Indoor atmospheres might be free of corrosion in "clean rooms" or subject to severe corrosion, as around a pickling bath in a steel mill.

Atmospheric conditions should be defined in terms of temperature, humidity, and contaminants, as well as their corrosivity to specific materials of construction being considered. In addition to the general atmospheric condition, special conditions such as cooling tower drift or spray, spills, or releases of water or chemicals should not be overlooked and must be taken into account.

4.2 Factors Affecting Atmospheric Corrosion

Atmospheric corrosion is an electrochemical process and as such depends on the presence of an electrolyte. The usual electrolyte associated with atmospheric corrosion is water resulting from rain, fog, dew, melting snow, or high humidity. Because an electrolyte is not always present, atmospheric corrosion is considered a discontinuous process. Corrosion takes place only during the time of wetness. It can be described by the equation:

$$K = \sum_L^h t_n V_k(n)$$

where K is the accumulated corrosion effect, t_n is the time of wetness (the period with an electrolyte layer on the surface), and V_k is the average corrosion rate during the individual periods of wetness, the composition of the electrolyte, and the temperature determine the corrosion rate. Factors affecting the time of wetness and the composition of the electrolyte film are discussed later.

In addition to the above, there are other factors that affect the corrosion rate. Included are initial exposure conditions, sample mass, orientation, extent of sheltering, wind velocity, nature of the corrosion products formed, and pollutants present (both known and unknown).

4.2.1 Time of Wetness

The term "time of wetness" refers to the length of time during which the metal surface is covered by a film of water that renders significant atmospheric corrosion possible. The actual time of wetness will vary with climatic conditions at the location. It depends on the relative humidity of the atmosphere (being greatest when the relative humidity is greater than or equal to 80%); the temperature of the air and the metal surface above 32°F (0°C); the duration and frequency of rain, fog, dew, and melting snow; as well as the hours of sunshine and wind speed.

Moisture on the surface of the metal resulting from high humidity of the atmosphere and the chemical and physical properties of the corrosion products produces an adsorption layer of water. Phase layers of water are the result of rain, fog, wet or melting snow, or dew formed by condensation on cold metallic surfaces.

The total time of wetness (T_{tw}) can be divided into the periods when the metal is moistened due to adsorption of water vapor on the surface (T_{ad}) and the periods when the surface is covered by a phase layer of water (T_{ph}) resulting from rain, fog, dew, or wet or melting snow:

$$T_{tw} = T_{ad} + T_{ph}$$

It is difficult to distinguish experimentally between the two periods of time of wetness because there is no sharp boundary.

4.2.1.1 Adsorption Layers

The amount of water adsorbed on a metal surface depends on the relative humidity of the atmosphere and on the chemical and physical properties of the corrosion products. The metal surface may be wetted if hygroscopic salts, deposited or formed by corrosion, absorb water from the atmosphere.

For such adsorption to take place, the relative humidity must be above a certain relative value known as the critical relative humidity. This value

depends on the specific metal and the surface contaminants. When the relative humidity exceeds the value at which the salt starts to absorb water and dissolve, the corrosion increases sharply. The critical relative humidity corresponds to the vapor pressure above a saturated solution of the salt present. The corrosion rate is directly affected by the amount of water present on the corroding surface.

4.2.1.2 Phase Layers

Phase layers may arise from precipitation of rain, fog, or wet or melting snow, or from dew formed by condensation on cold metallic surfaces.

4.2.1.2.1 Dew

Dew formation occurs when the temperature of the metal surface is below the dew point of the atmosphere. This may occur outdoors during the night, when the surface temperature may decrease by radiant heat transfer between the structure and the sky. Another reason for dew formation may be the conditions in the early morning, when the temperature of the air increases faster than the temperature of the metal, especially if the mass, and thus the heat capacity, of the metal is great. Dew may also form when metal products are brought into warm storage after cold transport.

Dew is a very important cause of corrosion, particularly under sheltered conditions. Compared to the amount of water on surfaces covered by adsorption layers, the amount of water on the surface resulting from dew is considerably greater. Because the washing effect is usually slight or negligible, periods of dew are considered very corrosive.

One factor responsible for the high corrosivity of dew is the large content of atmospheric contaminants present in dew. In heavily polluted industrial atmospheres, pH values lower than 3 have been reported. This applies to inert substrates, such as painted surfaces on which dry deposition between periods of rain can lead to the accumulation of fairly acidic corrosive pollutants.

4.2.1.2.2 Rain

Rain creates even thicker layers of electrolyte on the surface than dew. The thickness of the water layer retained on the surface has been estimated to be approximately 100 g/m². Precipitation in the form of rain affects corrosion by giving rise to a phase layer of moisture on the material surface and by adding corrosion stimulators in the form of, for example, H⁺ and SO₄²⁻. On the other hand, rain washes away pollutants deposited on the surface during the dry period. Whereas the first two processes promote corrosion, the third — at least in the case of steel — decreases corrosion. The significance of the two latter processes is dependent on the ratio between the dry and wet deposition periods.

In a strongly polluted atmosphere, corrosion on the skyward side of steel plates is substantially lower than on the downward side. In a strongly

polluted atmosphere, where dry deposition is considerably greater than the deposition of sulfur pollutants, the washing effect of rain dominates. In a less polluted area, the situation is reversed, which indicates that the corrosive action of rain, in this case, is more important.

The pH value of precipitation seems to be significant for metals whose corrosion resistance may be ascribed to a protective layer of basic carbonates or sulfates, as on zinc or copper. If the pH of rainwater falls to values close to 4 or even lower, this may lead to accelerated dissolution of the protective coatings.

4.2.1.2.3 Fog

Especially high acidity and high concentrations of sulfates and nitrate can be found in fog droplets in areas of high air pollution. In California, the pH of fog water has been found to be in the range of 2.2 to 4.0. The processes controlling fog water chemistry appear to be condensation of water vapor on and its evaporation from preexisting aerosol and scavenging of gas-phase nitric acid.

4.2.1.2.4 Dust

On a weight basis in many locations, dust is the primary air contaminant. When in contact with metallic surfaces and combined with moisture, dust can promote corrosion by forming galvanic or differential cells that, because of their hygroscopic nature, form an electrolyte on the surface. Suspended particles of carbon and carbon compounds, metal oxides, sulfuric acid, ammonium sulfate, sodium chloride, and other salts will be found in industrial atmospheres. It is these materials, when combined with moisture, that initiate corrosion.

The settled dust may promote corrosion by absorbing sulfur dioxide and water vapor from the air. Hygroscopic salts such as chlorides or sulfates form a corrosive electrolyte on the surface. Carbonaceous particles can start the corrosion process by forming cathodes in microcells with a steel surface.

Dust-free air is less likely to cause corrosion.

4.2.1.2.5 Measurement of Time of Wetness

For practical purposes, the time of wetness is usually determined on the basis of meteorological measurements of temperature and relative humidity. The period when the relative humidity is $\geq 80\%$ at temperatures greater than 32°F (0°C) is often used for estimating the actual time of wetness. The time of wetness determined by this method may not necessarily be the same as the "actual" time of wetness because wetness is influenced by the type of metal, the pollution in the atmosphere, the presence of corrosion products, and the degree of coverage against rain. The expression for time of wetness mentioned above, although not based on a detailed theoretical model, usually shows good correlation with corrosion data from field tests under outdoor conditions. This implies that this parameter corresponds to the kinetically decisive time periods during which corrosion proceeds. Under sheltered and

indoor conditions, however, other criteria seem to be valid, but have not yet been fully clarified.

The time of wetness can also be measured directly with electrochemical cells. The cell consists of thin metal electrodes (0.5 to 1 mm) separated from each other by thin insulation (0.1 to 0.2 mm). When the surface becomes wetted, a current starts to flow and the time of wetness is defined as the time when the cell current or the electromotive force exceeds a certain value. Not even the direct electrochemical measurement of the time of wetness will give an unambiguous value, because the result depends — among other factors — on the type of cell, its dimensions, the presence of corrosion products, and the definition of the threshold value of current or voltage that is considered the lower limit for the time of wetness. Most electrochemical techniques indicate mainly the time of wetness caused by phase layers of electrolyte, and they usually give lower values than calculations from meteorological data. Values between 1000 and 2700 hours per year (h/yr) are often reported from sites in the temperate climatic zone.

4.2.2 Composition of Surface Electrolyte

The electrolyte film on the surface will contain various species deposited from the atmosphere or originating from the corroding metal. The composition of the electrolyte is the determining factor of the corrosion process. The following provides a brief survey of the origin, transformation reactions, deposition mechanisms, and pollutants.

4.2.2.1 Oxygen

Oxygen is readily absorbed from the air, so that at least the outer region of the thin water film on the metal surface may be considered saturated with oxygen.

4.2.2.2 SO_x

The main part of anthropogenic SO_x pollution is caused by combustion of fossil fuels (i.e., oil and coal in industrial regions), which can cover less than 5% of the Earth's surface.

Most of the sulfur derived from the burning of fossil fuels is emitted in gaseous form as SO_2 . Both the chemical composition and the physical state of the pollutants change during their transport in the atmosphere. SO_2 is oxidized on moist particles or in droplets of water to sulfuric acid (H_2SO_4).

4.2.2.3 NO_x

Emissions of NO_x originate primarily from different combustion processes, road traffic, and energy production. Since 1940, the atmospheric emission of

NO_x relative to SO_2 (in equivalents) has increased markedly, which stresses the importance of NO_x emissions.

In combustion processes, most of the nitrogen oxides are emitted as NO.

4.2.2.4 Chlorides

Chlorides are deposited mainly in the marine atmosphere as droplets or as crystals formed by the evaporation of spray carried by the wind from the seas. Other sources of chloride emission are coal-burning and municipal incinerators. Most coals have a chloride content of 0.09 to 0.15%. In high-chlorine coals, values of 0.7% are found. In the burning of coal, most of the chlorine is emitted as gaseous HCl.

4.2.2.5 CO_2

Carbon dioxide (CO_2) occurs in the atmosphere in a concentration of 0.03 to 0.05% by volume, varying slightly with the time of day and the season of the year due to its cycle in nature.

4.2.2.6 Concentration of Different Species

The concentrations of the various species in the electrolyte on the surface vary greatly with respect to such parameters as deposition rates, corrosion rate, intervals between rain washings, the presence of rain shelter, and drying conditions.

It would be expected that the concentration in the electrolyte film will be low during a rainy period, while a highly concentrated solution may form after a long period without washing.

The pH of the water film is difficult to specify. A moisture film in contact with an atmosphere highly polluted with SO_x may initially have a pH value as low as 2. Due to the acid rain or fog, the moisture film may also have a low pH value. Because of reaction with the metal and the corrosion products, the pH value will usually increase. When a steady state has been reached, the pH is generally on the order of 5 to 6.

4.2.3 Temperature

The overall effect of temperature on corrosion rates is complex. During long-term exposure in a temperate climatic zone, the temperature appears to have little or no effect on the corrosion rate. As the temperature increases, the rate of corrosive attack will increase as a result of an increase in the rate of electrochemical and chemical reactions as well as the diffusion rate. Consequently, under constant humidity conditions, a temperature increase will promote corrosion; conversely, an increase in temperature can cause a decrease in the corrosion rate by causing a more rapid evaporation of the

surface moisture film created by rain or dew. This reduces the time of wetness, which in turn reduces the corrosion rate. In addition, as the temperature increases, the solubility of oxygen and other corrosive gases in the electrolyte film is reduced.

When the air temperature falls below 32°F (0°C), the electrolyte film might freeze. As freezing occurs, there is a pronounced decrease in the corrosion rate, which is illustrated by the low corrosion rates in the sub-arctic and arctic regions.

In general, temperature is a factor that influences corrosion rates but it is of little importance except under extreme conditions.

4.2.4 Initial Exposure

Atmospheric corrosion rates proceed through three stages or periods: the induction period, the transition period, and the stationary period. During the induction period, the metal is covered with a spontaneously formed oxide and the aqueous layer. This oxide provides some degree of protection, depending on the metal and the aggressiveness of the atmosphere. During the transition period, the oxide layer transforms into a fully developed layer of corrosion products. The final or stationary period is characterized by the surface being fully covered by corrosion product and eventually reaching constant properties with respect to chemical composition and stationary corrosion rates. The more aggressive the exposure conditions, the shorter the two initial periods (i.e., induction and transition). For example, in a benign (indoor) atmosphere, these initial periods for steel will last for years; but in highly polluted industrial areas, these initial periods might last only a few months.

Initial exposure conditions have a marked influence on the subsequent corrosion rate. During the first days of exposure, wet conditions (caused by high relative humidity or rainfall) cause higher corrosion rates than dry conditions. These effects will vary from one material to another. For example, zinc is more sensitive than steel. Differences are explained by the fact that different materials form different corrosion products with different protective properties. A wide variety of structurally related corrosion products can be found on zinc, the nature of which depends on initial exposure conditions. The seasonal dependence on the concentrations of peroxide and ozone in the atmosphere might also be a contributing factor.

During the third period of exposure, a constant corrosion rate is established — and thus the terminology “stationary period.”

4.2.5 Sheltering

The design of the installation should eliminate all possible areas where water, dirt, and corrosion products can accumulate. The degree of shelter from particle fallout and rainfall can affect the initial and ultimate corrosion

rates. When pockets are present, the time of wetness increases, which leads to corrosive conditions. The design should make maximum use of exposure to the weather. Sheltering from rain should be avoided.

4.2.6 Wind Velocity

Wind speed and type of wind flow have pronounced effects on the atmospheric corrosion rate. This is illustrated by the dry deposition velocity, which is defined as the ratio of deposition rate of any gaseous compound and the concentration of that compound in the atmosphere.

4.2.7 Nature of Corrosion Products

The atmospheric corrosion rate is influenced by many parameters, one of the more important being the formation and protective ability of the corrosion products formed. The composition of the corrosion products depends on the participating dissolved metal ions and the access to anions solved in the aqueous layer. The eventual thickening of the film of corrosion products can be described in a sequence of consecutive steps — dissolution → coordination → reprecipitation — where the dissolution step is acid dependent, the coordination is based on the hard and soft acid–base (HSAB) principle, and reprecipitation depends on the activities of the species involved.

Depending on the rate of crystallation and the rate of formation, the corrosion products may be amorphous or crystalline. If the former is rate determining, one expects amorphous phases to form. From colloid chemistry it is known that aging, or slow growth, of amorphous phases can result in a transition from the amorphous to the crystalline state, a process that may occur through slow transformation in the solid state or through the dissolution–reprecipitation process.

The corrosion products formed are the composition of the metal or alloy and the contaminants present in the atmosphere. For example, carbon steel does not have the ability to form its own protective coating except in a dry, clean atmosphere. Under this condition, a thick oxide film will form that prevents further oxidation. Initiation of corrosion is the result of the presence of solid particles on the surface. This settled airborne dust promotes corrosion by absorbing SO_2 and water vapor from the air. Even greater corrosive effects result when particles of hygroscopic salts, such as chlorides or sulfates, settle on the surface and form a corrosive electrolyte.

When small amounts of copper, chromium, nickel, phosphorus, silicon, manganese, or various combinations thereof are added to conventional carbon steel, low-alloy carbon steel results. These steels are known as weathering steels. The corrosion resistance of these steels depends on climatic conditions, pollution levels, the degree of sheltering from the atmosphere, and the specific composition of the steel. Upon exposure to most atmospheres, the corrosion rate becomes stabilized within 3 to 5 yr. A dark brown to violet

patina, or protective film, develops over this period. This patina is a rust formation that tightly adheres to the surface and cannot be wiped off. In rural areas with little or no pollution, a longer period may be required to form this film. In areas that are highly polluted with SO_2 , the weathering steels exhibit a much higher corrosion rate and loose rust particles form. Under these conditions, the film formed offers little or no protection.

Additional information regarding weathering steels and other metals or alloys as to their resistance to atmospheric corrosion can be found in the section dealing with the specific material.

4.2.8 Pollutants Present

One of the most important factors affecting atmospheric corrosion is the presence of specific pollutants. In areas having low atmospheric pollution, corrosion rates are correspondingly low. The presence of atmospheric pollutants such as the various oxides of nitrogen, sulfur-containing compounds, chlorine-containing compounds, and other, less common pollutants will stimulate corrosion.

It has been proven that the following gaseous constituents are of significant importance in contributing to atmospheric corrosion: O_2 , H_2O_2 , SO_2 , H_2S , COS , NO_2 , HNO_3 , NH_3 , HCl , HCHO , and HCOOH . Typical ranges of these materials found under outdoor and indoor conditions are given in Tables 4.1 and 4.2. They may be present as the result of either natural or anthropogenic processes, and may undergo a variety of chemical changes during transport in the atmosphere.

All of the species are reactive and as such have a certain average lifetime that is limited by their ability to react with atmospheric oxidizers, primarily the hydroxyl radicals OH^- and O_3 . OH^- is generated by photoinduced dissociation of O_3 (ozone) and the subsequent reaction of the electronically excited, energy-rich oxygen atom $\text{O} (^1\text{D})$ and water vapor:

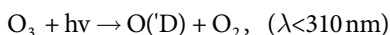

It is possible for the OH^- molecules to oxidize several of the species, such as SO_2 , H_2S , and NO . However, a large portion of the OH^- molecules is consumed through reactions with hydrocarbon molecules producing an end product of HO_2 (the hydroperoxyl radical). This radical converts to hydrogen peroxide (H_2O_2) and O_2 according to:

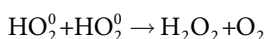

TABLE 4.1

Characteristics of Selected Gaseous Air Constituents

Gas	H	M/atm	Eq. Conc. (μM)		Deposition Velocity (cm/s)		Deposition Rate (ng/cm^2)	
			Outdoor	Indoor	Outdoor	Indoor	Outdoor	Indoor
O ₃	1.8	(-2)	2.3 (-4)	1.7 (-4)	0.05-1	0.036	5.8 (-3)	6.8 (-4)
H ₂ O ₂	2.4	(5)	4.2 (3)	1.2 (3)	—	0.07	—	5.0 (-4)
SO ₂	1.4	—	1.1 (-2)	2.9 (-3)	0.1-1.2	0.05	7.5 (-3)	2.7 (-4)
H ₂ S	1.5	(-1)	6.1 (-4)	4.0 (-5)	0.38	0.03	2.2 (-3)	1.1 (-5)
NO ₂	7.0	(-3)	1.9 (-4)	3.8 (-5)	0.2-0.8	0.006	2.0 (-2)	6.2 (-5)
HNO ₃	9.1	(4)	2.9 (2)	2.7 (2)	0.1-30	0.07	1.4 (-2)	5.5 (-4)
NH ₃	1.0	(1)	1.1 (-1)	5.8 (-1)	0.3-2.6	0.05	6.6 (-3)	2.1 (-3)
HCl	2.0	(1)	1.5 (-2)	1.9 (-3)	—	0.04	—	5.8 (-6)
Cl ₂	6.2	(-2)	1.2 (-6)	1.4 (-7)	1.8-2.1	—	1.1 (-4)	—
HCHO	1.4	(4)	1.1 (2)	1.4 (2)	—	0.005	—	6.3 (-5)
HCOOH	3.7	(3)	3.3 (1)	7.4 (1)	—	0.006	—	2.3 (-4)

Note: The equilibrium solution concentration and deposition rate values were based on correlations from Table 4.3, and using geometric mean values for the intervals, 1.8 (-2) means $1.8 \cdot 10^{-2}$.

Source: From Reference 25.

TABLE 4.2

Concentration of Selected Gaseous Air Constituents

Gas	Concentration (ppb)	
	Outdoor	Indoor
O ₃	4-42	3-30
H ₂ O ₂	10-30	5
SO ₂	1-65	0.3-14
H ₂ S	0.7-24	0.1-0.7
NO ₂	9-78	1-29
HNO ₃	1-10	3
NH ₃	7-16	13-259
HCl	0.18-3	0.05-0.18
Cl ₂	<0.005-0.08 ^a	0.001-0.005
HCHO	4-15	10
HCOOH	4-20	20

^a Corresponding to 5 wt% HCl.

Source: From Reference 24.

H₂O₂ is highly soluble in aqueous environments and is a powerful oxidizing agent.

However, the degree to which these pollutants will affect the corrosion rate will be influenced by other factors that also have an influence on the corrosion rate. The corrosive effect of these pollutants will depend on the specific material with which they come into contact. Succeeding sections deal with the mechanisms of corrosion of these pollutants and their effect on specific materials.

4.3 Mechanisms of Atmospheric Corrosion of Metals

Atmospheric corrosion takes place by means of an electrochemical process occurring in corrosion cells. A corrosion cell must have the following essential components:

1. A metal anode
2. A metal cathode
3. A metallic conductor between the anode and cathode
4. An electrolyte (water containing conductive salts) in contact with the anode and cathode but not necessarily of the same composition at the two locations

In addition, oxygen will usually be present as a depolarizing agent. For the cell to function, there must be a difference in potential between the anode and cathode. The difference in potential is mainly due to contact between dissimilar metallic conductors or differences in concentration of the solution, generally related to dissolved oxygen in natural waters. Almost any lack of homogeneity on the metal surface or in its environment may initiate attack by causing a differential in potentials that results in more or less localization of corrosion.

Atmospheric corrosion differs from the action that occurs in water or underground in that a plentiful supply of oxygen is always present. In this case, the formation of insoluble films, and the presence of moisture and deposits from the atmosphere, become the controlling factors. The presence of contaminants such as sulfur compounds and salt particles also affects the corrosion rate. Nevertheless, atmospheric corrosion is mainly electrochemical, rather than a direct chemical attack by the elements. The anodic and cathodic areas are usually quite small and close together, so that corrosion is apparently uniform rather than in the form of severe pitting as in soil or water. Anodes and cathodes exist on all steel surfaces. Surface imperfections, grain orientation, lack of homogeneity of the metal, variation in the environment, localized shear and torque during manufacture, mill scale, and existing iron rust will

produce anodes and cathodes. It is a relatively complicated system consisting of a metal, corrosion products, surface electrolyte, and the atmosphere.

For electrochemical reaction to proceed, two or more electrode reactions must take place: the oxidation of the metal (anodic partial reaction) and the reduction of an oxidizing agent (cathodic partial reaction). For the electrode reactions to take place, it is necessary that an electrolyte be present.

Most metals, if exposed to the atmosphere at room temperature with virtually no humidity present, will form an oxide film. If the oxide film is stable, the growth rate stops and the oxide film reaches a maximum thickness of 1 to 5 mm, protecting the metal.

Atmospheric corrosion falls into two categories: (1) "damp" atmospheric corrosion, which takes place in the presence of water vapor and traces of pollutants; and (2) "wet" atmospheric corrosion, which occurs when rain or other forms of bulk water are present, with pollutants. For atmospheric corrosion to proceed, water of some sort must be present.

Damp atmospheric corrosion occurs when water is present on the surface of the metal as an aqueous-phase layer, as caused by humidity, dew, or fog. Wet atmospheric corrosion occurs when bulk water is present, such as rain.

4.3.1 Damp Atmospheric Corrosion (Adsorption Layers)

Aqueous-phase layers consist of water adsorbed on the metal surface. The amount formed depends on the relative humidity of the atmosphere and the chemical and physical properties of the corrosion products.

Water may be adsorbed from the atmosphere and wet the metal surface if hygroscopic salts are deposited or formed by corrosion. This adsorption will take place when the relative humidity exceeds the critical relative humidity. The value of the critical relative humidity depends on the specific metal and the specific contaminants. When the relative humidity exceeds the value at which the salt starts to adsorb water and dissolve, the corrosion rate increases sharply. This critical relative humidity corresponds to a vapor pressure above a saturated solution of the salt present. Adsorption layers of electrolyte on the surface of the metal may also be the result of capillary condensation.

The corrosion rate is directly influenced by the amount of water present on the corroding surface. Laboratory studies have shown that the corrosion rate above the critical value sharply increases with increasing relative humidity. The amount of water present on a metal surface has been roughly estimated as follows:

Conditions	Amount of Water (g/m ²)
Critical relative humidity	0.01
100% Relative humidity	1
Covered by dew	10
Wet from rain	100

Atmospheric corrosion resulting from the reaction of water vapor with a metal surface is a serious problem. Most clean metal surfaces will permit the bonding of water in molecular form. The oxygen atom bonds to the metal surface and acts as a Lewis base (donating an electron pair), because the bonding is connected with a net charge transfer from the water molecule to the surface. The water adsorbs on electron-deficient sites.

It is also possible for water to bond in dissociated form. In this case, the driving force is the formation of metal–oxygen or metal–hydroxyl bonds. The end-products formed as a result of the water adsorption are adsorbed hydroxyl, atomic oxygen, and atomic hydrogen. When metal oxides are present, water may adsorb in either molecular or dissociative form. Lattice defect sites seem to facilitate dissociation, as observed, for instance, on monocrystalline TiO_2 , NiO , and $\infty\text{-Fe}_2\text{O}_3$. The dissociation of water forms a monomolecular thick film of surface hydroxyl groups that is relatively protective and reduces the subsequent reaction rate of water. The first monolayer of water adsorbed to the hydroxylated oxide surface is highly immobile, whereas the second and third layers are more randomly oriented and less immobile.

Many different metals adsorb water in similar manners, forming metal oxyhydroxides. The exact nature of the oxyhydroxide formed seems to have only a minor influence on the water adsorption phenomena. The quantity of reversibly adsorbed water increases with relative humidity and time. Refer to Table 4.3 for the approximate number of monolayers of water at 77°F (25°C) and steady-state conditions, as experimentally determined by the quartz crystal microbalance method on a number of metals.

Gaseous constituents of the atmosphere dissolve in the aqueous layers formed. Corrosive attack is generally found in areas where water adsorption is favored, permitting easy dissolution of the gaseous molecules such as SO_2 and NO_2 . The properties of wet atmospheric corrosion are approached when the aqueous films are greater than approximately three monolayers. At this point the relative humidity is close to the critical relative humidity. At values above the critical relative humidity, atmospheric corrosion rates increase

TABLE 4.3

Approximate Number of Water Monolayers
on Different Metals vs. Relative Humidity

Relative Humidity (%)	Number of Monolayers
20	1
40	1.5–2
60	2–5
80	3–10

Source: From Reference 24.

appreciably, whereas below this value, atmospheric corrosion is negligible. The critical relative humidity varies for different metals and pollutants.

4.3.2 Wet Atmospheric Corrosion (Phase Layers)

Wet atmospheric corrosion results from repeated wet and dry cycles, the presence of pollutants, and the formation of an aqueous layer in which the atmospheric pollutants dissolve. The wet cycles result from dew, fog, rain, or snow. In many cases, the dew, fog, rain, or snow may already contain the dissolved corrodent, which then deposits on the surface.

4.3.2.1 Dew

Dew is an important source of atmospheric corrosion — more so than rain — and particularly under sheltered conditions. Dew forms when the temperature of the metal surface falls below the dew point of the atmosphere. This can occur outdoors during the night when the surface temperature of the metal is lowered as a result of radiant heat transfer between the metal and the sky. It is also common for dew to form during the early morning hours when the air temperature rises more quickly than the metal temperature. Dew may also form when metal products are brought into warm storage after cold shipment.

Under sheltered conditions, dew is an important cause of corrosion. The high corrosivity of dew is a result of several factors:

1. Relatively speaking, the concentration of contaminants in dew is higher than in rainwater, which lowers the pH values. Heavy industrialized areas have reported pH values of dew in the range of 3 or lower.
2. The washing effect that occurs with rain is usually slight or negligible with dew.

With little or no run-off, the pollutants remain in the electrolyte and continue their corrosive action. As the dew dries, these contaminants remain on the surface to repeat their corrosive activity with subsequent dew formation.

4.3.2.2 Rain

Depending on the conditions, rain can either increase or decrease the effects of atmospheric corrosion. Corrosive action is caused by rain when a phase layer of moisture is formed on the metal surface. Rain causes thicker layers of electrolyte on the surface than dew. The corrosive activity is increased when the rain washes corrosive promoters such as H^+ and SO_4^- from the air (acid rain). Rain has the ability to decrease corrosive action on the surface of

a metal as a result of washing away the pollutants deposited during the dry spell.

Whether the rain will increase or decrease the corrosive action depends on the ratio of deposition between the wet and dry contaminants. When the dry period deposition of pollutants is greater than the wet period deposition of surface compounds, the washing effect of the rain will dominate and the corrosive action will decrease.

In areas where the air is less heavily polluted, the corrosive action of the rain will assume much greater importance because it will increase the corrosion rate.

Another factor affecting the relative corrosion rate resulting from rain is the orientation of the metal surface. In areas of heavy industrial pollution, skyward-facing metal surfaces benefit from rain. In those areas where dry deposition is considerably greater than wet deposition of sulfur pollutants, the washing effect of rain predominates, and the corrosion rate decreases. In areas having less pollution, the situation is reversed and the corrosive action of the rain predominates.

4.3.2.3 Fog

In areas having a high degree of air pollution, high acidity and high concentrations of sulfate and nitrate can be found in fog droplets. The pH of fog water has been found to be in the range of 2.2 to 4 in highly contaminated areas.

4.3.3 Deposit of Pollutants

Atmospheric pollutants can be deposited into the aqueous layer by either wet or dry deposition. For wet deposition to take place, it is necessary for the rain, fog, dew, or snow to be present; whereas for dry deposition, precipitation of any kind is not involved. Dry deposition is considered predominant indoors or in highly polluted areas close to emission sources. It is difficult to determine the relative importance of wet deposition because of the incidental nature of the precipitation.

Dry deposition is controlled by two factors: (1) aerodynamic processes and (2) surface processes. Aerodynamic processes relate to the actual depletion of the gaseous constituent in the atmosphere (e.g., SO_2), in the atmospheric region adjacent to the aqueous phase, and the ability of the system to add new SO_2 into this region. Whether or not new SO_2 can be introduced into the region depends on the actual wind speed, type of wind flow, and shape of the sample. The ability of the surface layer to accommodate the gaseous constituent (SO_2) is a phenomenon of the aqueous layer, which is a surface process. Greater amounts of gaseous constituents (SO_2) can be accommodated with increases in the thickness of the aqueous layer, resulting from increased relative humidity, the pH of the solution, and the alkalinity of the solid surface.

The dry deposition velocity is defined as the ratio of deposition rate, or surface flux, of any gaseous compound and the concentration of the same compound in the atmosphere. It can be expressed as the inverse of the sum of two resistances, namely, aerodynamic resistance and surface resistance:

$$V_d = \frac{1}{R_a + R_s}$$

where V_d is the dry deposition velocity, R_a is the aerodynamic resistance, and R_s is the surface resistance. In general, the dry deposition velocity will be the combined effect of both resistances. However, at highly turbulent air flow conditions, $R_a = 0$ and the dry deposition velocity depends only on the surface processes. Alkaline surfaces such as lead peroxide or triethanolamine are ideal absorbers of SO_2 for which $R_s = 0$. In this case, the dry deposition velocity depends on the aerodynamic processes. Typical ranges for dry deposition velocities onto various materials under outdoor and indoor conditions are given in Table 4.1

In outdoor conditions subject to wet-dry cycles, the actual concentration of most corrosion-stimulating gases under many conditions is not at equilibrium between the gas in the atmosphere and the same gas in the aqueous layer. Even so, thermodynamic considerations have been used for predicting the formation of different corrosion end-products and their stability. Figure 4.1 provides a schematic illustration of processes occurring in or at the aqueous layer.

4.4 Corrosion Products

One of the most important factors influencing the corrosion rate is the formation and protective ability of the corrosion products formed. The specific corrosion products formed depend on the participating dissolved metal ion and the access to anions solved in the aqueous layer. Formation of the film of corrosion products takes place in a sequence of consecutive steps — dissolution, coordination, reprecipitation. When the dissolution step is acid dependent, coordination is based on the hard and soft acid–base principle (i.e., hard acids preferably coordinate with hard bases and soft acids preferably coordinate with soft bases). Acids or bases with tightly held valence electrons that are not easily distorted are hard acids and bases. Acids or bases having valence electrons that are easily polarized or removed are considered soft acids or bases.

Based on experience with atmospheric corrosion, Table 4.4 indicates that hard acids like Cr^{3+} and Ti^{4+} form oxygen-containing films, whereas soft

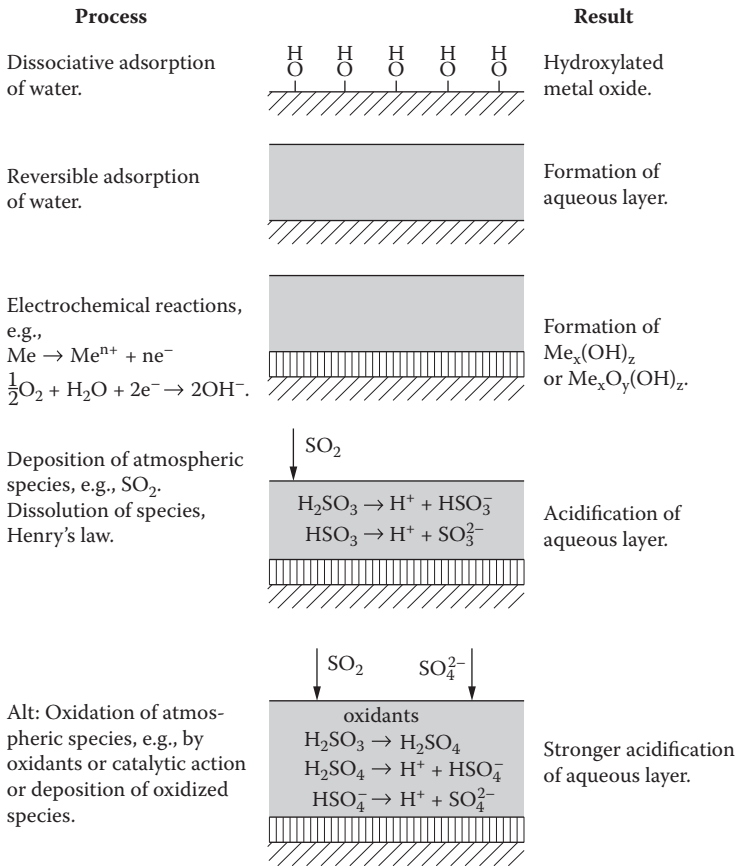

FIGURE 4.1
Schematic illustration of processes occurring in or at the aqueous layer. (Source: From Reference 1.)

TABLE 4.4

Classification of Hard and Soft Acids and Bases

Hard	Intermediate	Soft
<i>Acids:</i>		
$H^+, Na^+, Mn^{2+}, Al^{3+}$ $Cu^{3+}, Fe^{3+}, T, 4^+$	$Fe^2, Ni^{2+}, Cu^{2+}, Zn^{2+}+Pb^{2+}$	Cu^+, Ag^+
<i>Bases:</i>		
$H_2O, OH^-, O^{2-}, SO_4^{2-}, NO_3^-, Cu_3^{2-}$	SO_3^{2-}, NO_2^-	R_2S, RSH, RS

Source: From Reference 3.

acids such as Cu^+ and Ag^+ coordinate with reduced sulfur compounds. Intermediate acids such as Fe^{2+} , Cu^{2+} , and Zn^{2+} would be expected to coordinate with a broader range of bases.

The corrosion products formed may be amorphous or crystalline, depending on the rate of crystallization and formation. It is known that slow growth or aging of amorphous phases may result in a change to the crystalline state. This process can occur through slow transformation in the solid state or through dissolution–reprecipitation processes. Such is the case in the transformation from amorphous to crystalline state of nickel sulfates, with the former being less corrosion resistant than the latter.

4.5 Specific Atmospheric Corrodents

The atmospheric region closest to Earth is known as the troposphere and contains nitrogen (N_2), oxygen (O_2), and the rare gases neon (Ne), krypton (Kr), helium (He), and xenon (Xe). Of all the molecules involved, these make up 99.9% by weight and of these, only oxygen plays a part in atmospheric corrosion. The remaining constituents, nitrogen and the rare gases, due to their inability to react with metal surfaces, are not of significant importance to atmospheric corrosion.

Oxygen, because of its ability to accept electrons and its involvement in chemical transformations of the atmosphere, is particularly important to atmospheric corrosion. Other materials present in the troposphere that play a part in atmospheric corrosion are water and carbon dioxide. Water acts as an electrolyte; and carbon dioxide, which has a concentration of approximately 330 ppm and is highly soluble in water, contributes to the acidity of the aqueous layer.

Other trace gases present with a total concentration of less than 10 ppm, and also of importance in atmospheric corrosion, are O_3 , H_2O_2 , SO_2 , H_2S , COS , NO_2 , HNO_3 , NH_3 , HCl , Cl_2 , HCHO , and HCOOH . Either natural or anthropogenic processes are responsible for their presence, and they may undergo a variety of chemical changes during their presence in the troposphere. All species are reactive and exhibit a specific average lifetime, which is limited by their ability to react with important atmospheric oxidizers, specifically the hydroxyl radical OH^- and O_3 . The hydroxyl radical is formed by the photoinduced dissociation of ozone and the subsequent reaction of the electronically excited, energy-rich oxygen ion $\text{O}(\text{D})$ and water vapor:

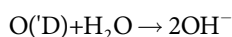
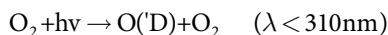

While it is possible for OH^- radicals to oxidize several of the corrosion-stimulating materials such as SO_2 , H_2S , and NO_2 , a large portion of the hydroxyl radicals are consumed through reactions with hydrocarbon molecules, producing the hydroperoxyl radical HO_2 , which disproportionates into hydrogen peroxide (H_2O_2) and oxygen (O_2) according to:

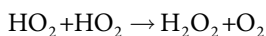

Hydrogen peroxide is a powerful oxidizing agent that is highly soluble in water.

4.5.1 Sulfur-Containing Compounds

The most important corrosive contaminant found in industrial atmospheres is sulfur dioxide (SO_2), which results from the combustion of sulfur-containing coal and oil, and emission from metal, petrochemical, and pulp and paper industries. Once in the atmosphere, SO_2 undergoes physical and chemical state changes. Depending on the environment, SO_2 is capable of being oxidized in one or more of the following ways:

GM

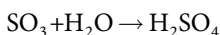
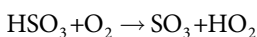
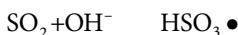

where GM represents another gaseous molecule, such as nitrogen or oxygen, that collides with an HSO_3 molecule and removes some of the excess energy released.

In the aqueous phase:

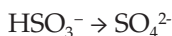
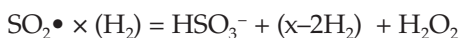
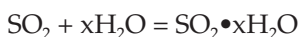

On moist particles or in droplets of water, the SO_2 can be oxidized to sulfuric acid:

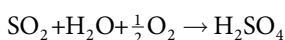

SO₂ has a lifetime in the atmosphere of 0.5 to 2 days. This limits the distance that SO₂ can be transported to a few hundred kilometers. During this period, the sulfuric acid may be partially neutralized, particularly with ammonia that results from the biological decomposition of organic matter. When this occurs, particles containing ammonium sulfate, (NH₄)₂SO₄, and different forms of acid ammonium sulfate, such as NH₄HSO₄ and (NH₄)₃H(SO₄)₂, are formed.

Atmospheric corrosion results from the deposition of these various materials on metal surfaces. Deposition of sulfur compounds can be accomplished by:

1. Dry deposition:
 - a. Adsorption of gas (SO₂) on metal surfaces
 - b. Impaction of sulfur particles
2. Wet deposition:
 - a. Removal of gas from the atmosphere by precipitation in the form of rain or fog

The primary cause of atmospheric corrosion is dry deposition, which consists mainly of the adsorption of SO₂. The amount deposited is proportional to the concentration in the atmosphere. Different materials are subject to different deposition rates. Rusty steel surfaces will adsorb SO₂ quantitatively at high relative humidities, whereas the deposition on copper, and particularly aluminum is much less. The rate of dry deposition of other sulfur compounds is less than that of SO₂.

Sulfates are deposited primarily by wet deposition and experience a lifetime of 3 to 5 days. This permits these particles to be transported a distance on the order of 1000 km. Sulfate concentrations are usually less than SO₂ concentrations close to the emission source.

The primary cause of atmospheric corrosion is the dry deposition of SO₂ on metallic surfaces. This type of corrosion is usually confined to areas having a large population, many structures, and severe pollution. Therefore, the atmospheric corrosion caused by sulfur pollutants is usually related to an area close to the source.

Under these conditions, dry deposition of SO₂ is considered the most important sulfur deposition process for the corrosion of structural metals.

As previously stated, the deposition rate depends on the concentration in the air. Because this concentration can vary considerably, it is difficult to give ranges. Order of magnitude deposition rates for SO₂ in various types of atmospheres are as follows:

Type of Atmosphere	Deposition Rate (mg SO ₂ /m ² -day)
Rural	<10
Urban	10–100
Industrial	Up to 200

Another atmospheric stimulant is hydrogen sulfide (H_2S). Natural biological sources (such as volcanoes, moss, or damp swamp areas) and anthropogenic sources (such as pulp and paper industries, catalytic converters in motor vehicles, sewage plants, garbage dumps, animal shelters, and geothermal plants) are responsible for the emission of H_2S . Hydrogen sulfide can cause the tarnishing of silver and copper by the formation of tarnish film. It can react with OH^- to form SO_2 as follows:

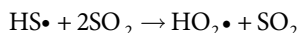
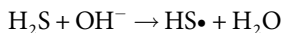

4.5.2 Nitrogen-Containing Compounds

High-temperature combustion processes such as in power plants, vehicles, etc. produce NO and NO_2 . The combustion gas produced has a much higher percentage of NO and NO_2 ; however, the NO is rapidly converted to NO_2 according to:

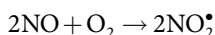

At distances further from the emission source, the NO may also form NO_2 through the influence of ozone (O_3) as follows:

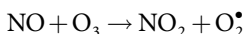

The primary nitrogen pollutant near the emission source is nitrogen dioxide (NO_2). The ratio of NO_2 to NO in the atmosphere varies with time and distance from the emission source and is usually between 10 and 100. NO_2 can be oxidized to nitric acid according to:

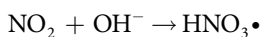

In addition, NO can be oxidized to nitric acid according to the overall reaction:

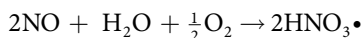

Because this reaction has a very low rate, the concentrations of HNO_3 and nitrates in the immediate area of the emission source are low.

NO_2 , by absorbing solar light and the subsequent formation of ozone through:

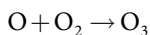
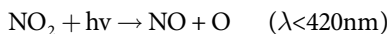

plays an important part in atmospheric chemistry.

The mechanisms by which nitrogen compounds are deposited are not completely understood. Wet deposition seems to be the primary mechanism at long distances from the emission source, while in the immediate area of the emission source, dry deposition of nitrates appears to dominate. This is due to the fact that NO and NO₂ have a low solubility in water whereas HNO₃, which is highly soluble in water, has not yet formed.

Ammonia (NH₃) is emitted primarily from animal shelters, cleaning detergents, and fertilizer production. Ammonia in the aqueous phase establishes equilibrium with NH₄⁺,

which results in increased pH. NH₃ affects atmospheric corrosion chemistry by neutralizing acidifying pollutants, and forming particulate ammonium sulfate ((NH₄)₂SO₄) and acid ammonium sulfates such as NH₄HSO₄ and (NH₄)₃H(SO₄)₂.

4.5.3 Chlorine-Containing Compounds

In marine environments, chlorine deposition is in the form of droplets or crystals formed by evaporation of spray that has been carried by wind from the sea. As the distance from the shore increases, this deposition decreases as the droplets and crystals are filtered off when the wind passes through vegetation or when the particles settle by gravity.

Other important sources of chloride emission are coal-burning municipal incinerators, and de-icers and dust binders on roads. Most coals have a chlorine content of 0.09 to 0.15%. Values as high as 0.7% have been found in high-chlorine coals. The combustion of these coals produces an emission of gaseous hydrogen chloride (HCl) that is highly soluble in water and strongly acidifies the aqueous phase.

Many industrial processes, such as bleaching plants in pulp and paper industries, certain metal production facilities, and cleaning detergents, emit chlorine (Cl₂). Cl₂ can photodissociate into chlorine radicals that react with organic compounds (RH) to form HCl:

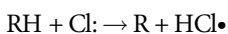
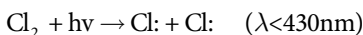

4.5.4 Carbon Dioxide (CO₂)

Carbon dioxide (CO₂) occurs naturally in the atmosphere in concentrations of 0.03 to 0.05% by volume. This concentration varies with the time of day and the season of the year. The above percentages correspond to a concentration of the order 10⁻⁵ mol/L when at equilibrium in the water film, if the pH value is 6 or lower.

4.5.5 Oxygen (O₂)

Oxygen is a natural constituent of air and is readily absorbed from the air into a water film on the metal surface, which is considered saturated, thereby promoting any oxidation reaction.

4.5.6 Indoor Atmospheric Compounds

Formaldehyde (HCHO) and formic acid (HCOOH) are important indoor corrosion stimulants that can originate from tobacco smoke, combustion of biomass, adhesives, and plastics. In general, the concentration of these stimulants is lower indoors than outdoors, except for ammonia and the organic species, which usually have a higher concentration indoors than outdoors. This higher level is the result of anthropogenic activity.

4.6 Summary

The concentrations of pollutants found in both indoor and outdoor atmospheres can vary greatly as a result of the type of atmosphere and/or the geographic location. It is almost impossible to provide a specific range for a specific location unless air samples are taken and analyzed. Listed below are some typical indoor and outdoor ranges of inorganic pollutants as found in the United States.

Pollutant	Outdoor Range (µg/m ³)	Indoor Range (µg/m ³)
SO ₂	3–185	1–40
NO ₂	20–160	3–60
H ₂ S	1–36	0.2–1
O ₃	10–90	7–65
HCl	0.3–5	0.08–0.3
NH ₃	6–12	10–150
Cl ₂	<5% of HCl levels except where local source exists	0.004–0.015

4.7 Resistance of Specific Metals and Alloys to Atmospheric Corrosion

The factors affecting the mechanisms of atmospheric corrosion have been discussed. However, these factors and mechanisms have different effects and react in different manners with different metals and alloys. Each metal or alloy forms its own protective film of corrosion products, some of which have greater protection than others.

These protective films tend to reduce the corrosion rate with time; eventually the corrosion rate reaches a steady state and changes very little upon further exposure. This is characteristic of all metals and alloys. The average atmospheric corrosion rate of various metals (in mils/year; mpy) are shown below:

Metal	Atmosphere					
	Urban/Industrial		Marine		Rural	
	10 Years	20 Years	10 Years	20 Years	10 Years	20 Years
Aluminum	0.032	0.029	0.028	0.025	0.001	0.003
Copper	0.047	0.054	0.032	0.050	0.023	0.017
Lead	0.017	0.015	0.016	0.021	0.019	0.013
Nickel	0.128	0.144	0.004	0.006	0.006	0.009
Monel	0.053	0.062	0.007	0.006	0.005	0.007
Zinc, 99.9%	0.202	0.226	0.063	0.069	0.034	0.044

4.7.1 Carbon Steel

Carbon steel is the most widely used material of construction. It is the primary material of choice for bridges, towers, various types of structures, and other outdoor types of construction.

Up until the last 25 or so years, atmospheric corrosion of steel was believed to be a process of general corrosion proceeding in cells with microscopic anodes and cathodes. More recent studies have determined that the corrosion process, which is electrochemical in nature, takes place in cells of microscopic dimensions with very distinct anodic and cathodic areas.

Atmospheric corrosion of steel is a function of location. In country air, the products of corrosion are either oxides or carbonates. In industrial atmospheres, sulfuric acid is present, and near the ocean some salt is in the air. Corrosion is more rapid in industrial areas because of the presence of the acid, and it is higher both near cities and near the ocean because of the higher electrical conductivity of the rain and the tendency to form soluble chloride or sulfate, which cause the removal of protective scale.

When steel is exposed in a clean, dry atmosphere, the surface is covered with a 20- to 50-Å-thick oxide film consisting of an oxide layer of Fe_2O_3 . This film practically prevents further corrosion. If small amounts of water vapor are present, FeOOH may also form.

In noncontaminated atmospheres, the initiation of corrosion on a clean metal surface is a very slow process, even if the atmosphere is saturated with water vapor. Under these conditions, initiation of corrosion may occur at surface inclusions of MnS , which dissolve when the surface becomes wet. However, the presence of solid particles on the surface is a more important factor for the start of corrosion. Airborne dust that has settled on the steel surface may prompt corrosion by absorbing SO_2 and water vapor from the atmosphere. Of greater significance are particles of hygroscopic salts, such as sulfates or chlorides, that form a corrosive electrolyte on the surface. Cathodes in microcells may also be formed by carbonaceous particles settling on the steel surface. Cathodes may also be formed by residues of mill scale on the surface, initiating corrosion when the surface becomes wet. Rusting is rapidly initiated in SO_2 polluted atmospheres at high humidity, even in the absence of any particles on the surface.

Because carbon steel is not capable of developing its own protective coating in corrosive atmospheres, unalloyed steel used in outdoor applications is usually protected with a coating of antirust paint, or zinc or aluminum. For the paint coating to be effective, surface preparation prior to painting is extremely important.

The environment to which the steel will be exposed will determine the proper method of surface preparation as well as the proper type of paint coating to apply. Milder environments, such as building interiors, require a less thorough surface preparation than do surfaces that will be exposed to more severe environments. The following table provides the general surface preparation requirements based on the environment to which the steel will be exposed.

Environment	Recommendation
1. Dry interior: building interior or outside exposure in an arid climate	Minimal hand or power tool cleaning; painting for color, aesthetics only
2. Normally dry but exposed to weather: some bridges, building, steel, etc.	Hand or power tool cleaning
3. Frequently wet or exposure to high humidity: bridges, tanks, topside of ships, steel in paper mills, sewage treatment plants, etc.	Blast clean or pickle

More specific details referring to surface preparation and paint selection can be found in Schweitzer, P.A., 2006, *Paint and Coatings, Application and Corrosion Resistance* (CRC Press, Taylor and Francis Group LLC, Boca Raton, FL).

4.7.2 Weathering Steels

Weathering steels are steels to which small amounts of copper, chromium, nickel, phosphorus, or various combinations thereof have been added. This results in a low-alloy carbon steel that has improved corrosion resistance in rural areas exhibiting low pollution levels. Factors that affect the corrosion resistance of these steels are:

- Climatic conditions
- Pollution levels
- Degree of sheltering from the atmosphere
- Specific composition of the steel

Exposure to most atmospheres results in a corrosion rate that becomes stabilized in 3 to 5 years. Over this period of time, a protective film or patina, dark-brown to violet in color, forms. This patina is a tightly adhering rust formation on the surface of the steel that cannot be wiped off. Because the formation of this film depends on the pollution in the air, in rural areas where there may be little or no pollution, a longer time may be required to form this film. In areas that have a high level of SO_2 , loose rust particles are formed with a much higher corrosion rate. This film of loose particles offers little or no protection against continued corrosion.

When chlorides are present, such as in a marine environment, the protective film will not form. Under these conditions, the corrosion rates of the weathering steels are equivalent to that of unalloyed carbon steel.

To form the patina, a series of wet and dry periods is required. If the steel is installed in such a manner as to be sheltered from the rain, the dark patina does not form. Instead, a rust lighter in color forms that provides the same resistance. The corrosion rates of the weathering steels will be the same as the corrosion rate of the unalloyed steel when it is continuously exposed to wetness such as in water or soil.

Because the dark brown patina formed has a “pheasant” appearance, the weathering steels can be used without the application of any protective coating of antirust paint, zinc, or aluminum. This is particularly true in urban and rural areas.

To receive the maximum benefit from the weathering steels, consideration must be given to the design. The design should eliminate all possible areas where dirt, water, and corrosion products can accumulate. When pockets are present, the time of wetness increases, which leads to the development of corrosive conditions. The design should make maximum use of exposure to the weather. Sheltering from rain should be avoided.

While the protective film is forming, rusting will proceed at a relatively high rate, during which time rusty water will be produced. This rusty water may stain masonry, pavements, and the like. Consequently, steps should be taken

to prevent detrimental staining, effects such as coloring the masonry brown, so that any staining will not be obvious. The ground area exposed to staining can be covered with an easily exchangeable material, such as gravel.

The corrosion mechanism for weathering steels is similar to that of unalloyed carbon steels. The rust forms a more dense and compact layer on the weathering steels than on unalloyed carbon steels. The rust layer more effectively screens the steel surface from the corrosive environments of the atmosphere. The corrosion process may be affected in several ways by this rust layer. The cathodic reaction may be affected by the low diffusion rate of oxygen, whereas the anodic reaction may be retarded by limiting the supply of water and corrosion-stimulating ions that can reach the surface of the steel. In addition, the increased electrolyte resistance may also decrease the corrosion rate.

Each of the alloying ingredients reacts in a different manner to improve the resistance of the weathering steels to atmospheric corrosion.

Copper has the most pronounced effect of any of the individual elements in decreasing the corrosion rate. An increase in the copper content from 0.01 to 0.4% decreases the corrosion rate by up to 70%. Only a slight improvement in the corrosion resistance results from an increase in copper in the range of 0.2 to 0.5%. Several theories have been proposed regarding the mechanism by which copper improves the corrosion resistance. One theory is that the beneficial effect is due to the formation of a surface coating of metallic copper that acts as either protection in itself or promotes anodic passivation by supporting the cathodic reaction. Another theory is that copper ions dissolved from the base metal are able to precipitate sulfide ions originating either from sulfide inclusions in the steel or from atmospheric pollution, and thus eliminate their detrimental effect. The most probable theory is that copper forms basic sulfates with low solubility, which precipitate within the pores of the rust layer, thereby decreasing their porosity. Weathering steels usually contain 0.2 to 0.5% copper.

When added in combination with copper, chromium and nickel further increase the resistance of weathering steels. Chromium is usually added in a content of 0.4 to 1%, whereas nickel is usually added up to 0.065%. Chromium appears to be more effective than nickel. The mechanical properties of the steel are improved by both elements.

Chromium is enriched in the inner rust layer together with copper and phosphorus. They promote the formation of a dense layer of amorphous FeOOH next to the steel surface. This layer acts as a barrier to the transport of water, oxygen, and pollutants. Nickel is supposed to act by forming insoluble basic sulfates in pores of the rust layer.

Phosphorous also helps to improve the corrosion resistance of weathering steels. By increasing the phosphorous content from less than 0.01% to 0.1%, a 20 to 30% improvement in the corrosion resistance of copper-bearing steels is realized. Phosphorus may form layers of insoluble phosphates in the rust, acting as transportation barriers in the same manner as the

TABLE 4.5

Atmospheric Corrosion of Various Steels in Different Atmospheric Types

Atmospheric Type	Exposure Time (yr)	Carbon Steel	Average Reduction in Thickness (mil)	
			A242 (K11510) Cu-P Steel	A558 (K11430) Cr-V-Cu Steel
Urban	3.5	3.3	1.3	1.8
Industrial	7.5	4.1	1.5	2.1
Rural	3.5	2.0	1.1	1.4
	7.5	3.0	1.3	1.5
Severe marine 80 ft (25 m) from ocean	0.5	7.2	2.2	3.8
	2.0	36.0	3.3	12.2
	3.5	57.0	—	28.7
	5.0	Destroy	19.4	38.8

Source: From Reference 4.

basic sulfates previously mentioned. A comparison of the corrosion rates of carbon steel, a copper-phosphorus low-alloy steel, and a chromium-vanadium-copper low-alloy steel is provided in Table 4.5.

4.7.3 Zinc

Zinc is more resistant to atmospheric corrosion than carbon steel. The rate of corrosion of zinc is influenced primarily by the time of wetness and the presence of pollution in the air, specifically CO_2 , SO_2 , and Cl^- .

Zinc is a relatively basic metal. Atmospheric corrosion of zinc starts with the instantaneous formation of a film of zinc hydroxide, which may occur in different crystal structures, and the subsequent formation of basic zinc carbonate $\text{Zn}_3(\text{CO}_3)_2(\text{OH})_6$. The pH of the aqueous layer controls the stability of initial corrosion products and results in the dissolution of Zn^{2+} .

The corrosion process appears to proceed according to the following mechanism (refer to Figure 4.2). Zinc is oxidized to form zinc hydroxide in moist outdoor environments:

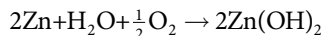

This reaction, being electrochemical, involves the anodic oxidation of zinc and the cathodic reduction of oxygen.

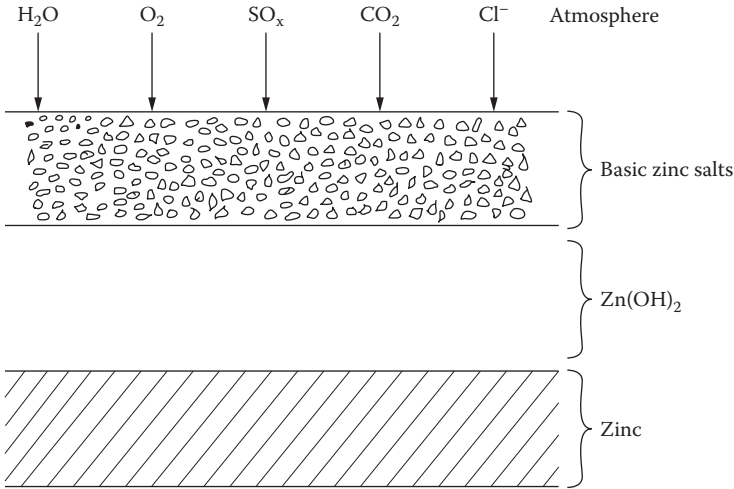
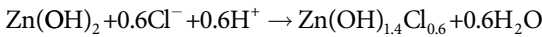
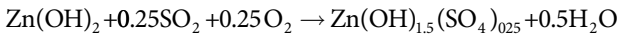
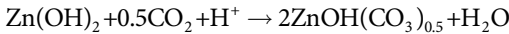
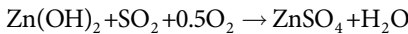
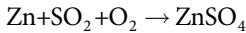

FIGURE 4.2 Corrosion products formed on zinc during atmospheric exposure. (Source: From Reference 5.)

If the pH value of the surface moisture is sufficiently high, the zinc hydroxide formed reacts with pollutants present (e.g., CO₂, SO₂, and O₂) to form the corresponding zinc salts, at the hydroxide/air interface.



The zinc hydroxide and the basic zinc salts form the zinc patina that protects the surface from further attack as long as the pH remains high. If, due to heavy air pollution with SO_x or from acid rain, the pH of the surface moisture has a low value, no zinc hydroxide or basic salt is formed. In addition, any of the basic products previously formed may be dissolved.



Zinc sulfate is soluble in water and may be washed away by rain, leaving the zinc unprotected and producing a high corrosion rate. The protective coating may also be damaged by abrasion and erosion.

As can be seen, the composition of the atmosphere will be a determining factor in the corrosion product formed and will determine whether or not the corrosion product will have protective properties. Shown below are the various corrosion products that may be formed, depending on the type of atmosphere present.

Atmospheric Type	Corrosion Products
Urban or industrial	$Zn \rightarrow Zn(OH)_2 \rightarrow ZnOH(CO_3)_{0.5}$
	$Zn \rightarrow Zn(OH)_2 \rightarrow ZnOH(CO_3)_{0.5} \rightarrow ZnSO_4$
	$Zn \rightarrow Zn(OH)_2 \rightarrow Zn(OH)_{1.5} (SO_4)_{0.25}$
	$Zn \rightarrow Zn(OH)_2 \rightarrow Zn(OH)_{1.5} (SO_4)_{0.25} \rightarrow ZnSO_4$
	$Zn \rightarrow ZnSO_4$
Marine	$Zn \rightarrow Zn(OH)_2 \rightarrow Zn(OH)_{1.4} Cl_{0.6}$
Rural	$Zn \rightarrow Zn(OH)_2 \rightarrow ZnOH(CO_3)_{0.5}$

Because of this, the prolonged exposure of zinc can follow a number of different reaction path sequences, depending on the actual deposition rates of the atmospheric pollutants.

Basic zinc carbonate may continue to grow slowly in a rural atmosphere relatively free of pollutants or it may be followed by the formation of a protective basic zinc sulfate ($Zn_4SO_4(OH)_6 \cdot H_2O$).

When higher amounts of Cl^- than of SO_2 are deposited, as in a marine atmosphere, islands of a less protective basic zinc chloride ($Zn_5Cl_2(OH)_8 \cdot H_2O$) are formed within days of exposure. These islands grow laterally and coalesce. A more protective basic zinc chlorosulfate ($NaZn_4Cl(OH)_6 SO_4 \cdot 6H_2O$) may form within weeks of exposure.

When higher amounts of SO_2 than Cl^- are deposited, as in an urban environment, the basic zinc sulfate, $Zn_4SO_4(OH)_6 \cdot H_2O$, is formed within weeks of exposure. This is followed eventually by the formation of another basic zinc sulfate ($Zn_4Cl_2(OH)_4SO_4 \cdot 5H_2O$) in highly polluted industrial atmospheres.

In rural and urban atmospheres, the penetration depth is generally reported to be an approximately linear function of the exposure time. However, it has been determined that this holds true only for skyward-exposed surfaces. Groundward surfaces in urban atmospheres, as well as groundward and skyward surfaces in marine atmospheres, show nonlinear relations with time in accordance with the power law:

$$p = kt^n$$

where the values of the constants k and n vary with exposure conditions.

Zinc is also susceptible to a high corrosion rate when so-called white rust is formed in crevices where moisture collects. The white color is due to the formation of zinc carbonate, which does not form a corrosion-limiting

protective film on the base metal. Due to the lack of protective film formation, white rust corrosion will continue until the protective zinc coating is entirely removed from the underlying steel, which is then subjected to accelerated corrosion and premature failure. White rust will occur whenever zinc or galvanized steel is exposed to water that has a pH value above 8.2. The corrosion rate is governed by the alkalinity of the water and the presence of any accelerating agents. Why the basic zinc carbonate cannot form has not been established. It may be due to long-lasting moistening or to a poor supply of CO_2 . White rust is more prevalent during rainy seasons. It may also form on moist zinc surfaces in contact with mineral wool, which prevents access of air and drying. This condition may happen in heat-insulated wall structures containing galvanized steel members.

In years gone by, zinc coating of steel (galvanizing) was considered a satisfactory corrosion-resistant material for structures in outdoor atmospheres. The corrosion rate was only 0.5 to 1.0 $\mu\text{m}/\text{yr}$. However, the corrosion rate has been increasing in many urban or industrial areas as a result of increasing pollution by SO_2 . Corrosion rates have reached 5 $\mu\text{m}/\text{yr}$ or more in many areas. Because of this, it is often necessary to apply to galvanized steel a coat of anticorrosion paint for added protection.

4.7.4 Zinc and Zinc Alloy Coatings on Steel

Galvanized steel is steel that has been coated with zinc. The galvanizing process is widely used to protect steel from atmospheric corrosion. Structures, sheet steel, wire, and piping are all forms that are protected by galvanizing.

The protection afforded in rural areas is greater than that in urban or industrial atmospheres. In the latter areas there is a greater concentration of industrial pollutants. The air in these areas is contaminated with various sulfur compounds, which together with the moisture in the air convert the normally impervious corrosion-resistant zinc carbonate and zinc oxide layer into zinc sulfate and zinc sulfite. These water-soluble compounds have poor adhesion to the zinc surface and therefore are washed away relatively easily by rain. This exposes the underlying surface to attack by oxygen in the air.

A galvanized steel coating normally corrodes in the same manner as solid zinc. In areas where the zinc coating is defective, the exposed steel, under most conditions, is cathodically protected. Because of the iron-zinc alloy present in most galvanized coatings, galvanized surfaces have a higher corrosion resistance than zinc in neutral and acid conditions. Zinc coatings on steel exposed to air corrode in the same manner as solid zinc, and there is an approximate linear relationship between weight loss and time. In industrial atmospheres, the purity of the coating has little effect on the corrosion rates.

Protection of galvanized surfaces from atmospheric corrosion is due to the formation of basic salts, primarily carbonate. The most widely accepted formula is $\text{Zn}_5(\text{OH})_6(\text{CO}_3)_2$. The galvanized surface of zinc is rapidly attacked when environmental conditions lead to the formation of soluble film. One of

the most important factors affecting the corrosion of zinc in the atmosphere is the duration and frequency of moisture contact.

Because a thin film of moisture with a high oxygen concentration promotes corrosion, the rate of drying time is an important factor. Under normal exposure conditions, the films dry rapidly, and it is only in sheltered areas that drying times are so slow that the attack of zinc is accelerated.

The effect of atmospheric humidity on the corrosion of zinc is related to the conditions that may cause condensation of moisture on the metal surface and to the frequency and duration of the moisture contact. Moisture is deposited when the air temperature drops below the dew point. The quantity of dew deposited is influenced by the thickness of zinc, and its surface roughness and cleanliness. When the temperature of the metal surface falls below the air temperature in a humid atmosphere, moisture condenses on the metal. If the water evaporates quickly, corrosion is not severe and a protective film forms on the surface. If water from rain or snow remains in contact with zinc, when access to air is restricted and the humidity is high, the resulting corrosion can appear to be severe because the formation of a protective basic zinc carbonate is prevented.

Atmospheric corrosion of zinc is roughly proportional to the time of wetness in a particular location, provided the nature and quantity of environmental pollution do not change. A high relative humidity, which can cause condensation, increases corrosion.

Time of wetness is normally secondary to the effect of atmospheric pollutants, primarily sulfur dioxides and other acid forming pollutants, which have a direct effect and can also make rain more acidic. In less corrosive areas, time of wetness assumes a greater proportional significance.

Sulfur dioxide is a primary pollutant leading to the atmospheric corrosion of zinc. It controls the corrosion rate when the relative humidity is in the area of 70% or above. Sulfur oxides and other air pollutants are deposited on zinc surfaces either by dry or wet deposition. Regardless of the method of deposition, the sulfur dioxide deposited on the zinc surface forms sulfurous or other strong acids, which react with the protective zinc oxide, hydroxide, or basic carbonate film to form zinc sulfate. The film of protective corrosion products is destroyed by the acids, which reforms from the underlying metal, causing the continuous corrosion by an amount equivalent to the film dissolved, and hence to the amount of sulfur dioxide absorbed. Corrosion rates increase even further when the relative humidity exceeds 85%.

Atmospheric chlorides will lead to the corrosion of zinc, but to a lesser degree than the corrosion of steel, except in brackish water and flowing seawater. Any salt deposit should be removed by washing. Chlorides also have a much smaller effect on the corrosion rate of zinc than sulfur compounds. The salt content of the atmosphere will usually decrease rapidly inland further away from the coast. Corrosion also decreases with distance from the coast but the change is more gradual and erratic because chloride is not the primary pollutant affecting zinc corrosion. Chloride is most harmful when

combined with acidity resulting from sulfur gases, as would be found in highly industrialized coastal areas.

Other pollutants also have an effect on the corrosion of galvanized surfaces. Deposits of soot or dust can be detrimental, both because of their specific nature and because they have the potential to increase the risk of condensation on the surface and hold more water in position. This is prevalent on upward-facing surfaces. Soot (carbon) absorbs large quantities of sulfur, which are released by rainwater.

In rural areas, over-manuring of agricultural land tends to increase the ammonia content in the air. The presence of normal atmospheric quantities of ammonia does not accelerate zinc corrosion, and petrochemical plants where ammonium salts are present show no accelerated attack on galvanized steel. However, ammonia will react with atmospheric sulfur oxides, producing ammonium sulfate, which accelerates paint film corrosion as well as zinc corrosion.

When ammonium reacts with NO_x compounds in the atmosphere, ammonium nitrite and nitrate are produced. Both compounds increase the rate of zinc corrosion, but less so than SO_2 and SO_3 .

4.7.4.1 Zinc-Aluminum Hot Dip Coatings

Combinations of zinc and aluminum are the most important series of alloys. These have been developed to improve the atmospheric corrosion resistance of galvanized coatings. The two primary hot dip coatings are Galfan, which is a zinc-5% aluminum alloy, and Galvalume, which is a zinc-55% aluminum-1.5% silicon alloy. Galfan coatings have a corrosion resistance up to three times that of galvanized steel. The main difference between these two coatings lies in the degree of cathodic protection they afford.

Galfan finds application in a mild urban-industrial atmosphere and in a marine atmosphere. This latter application is particularly important because the corrosion rate slows after about 4 yr, whereas conventional galvanized steel shows rust in 5 yr. This slower rate of corrosion is evidence that the zinc-5% aluminum coatings provide full cathodic protection to cut edges over a longer period of time.

Galvalume provides good protection in urban-industrial atmospheres but at the expense of reduced cathodic protection. The corrosion rate of these coatings also tends to diminish after a year or two.

4.7.4.2 Zinc-Aluminum Thermally Sprayed Coatings

Zinc-15% aluminum coatings are available as thermally sprayed coatings. These coatings have a two-phase structure consisting of a zinc-rich and an aluminum-rich phase. The oxidation of the zinc-rich phase takes place within the more inert aluminum-rich phase. The oxidation products formed are encapsulated in the porous layer formed by the latter and do build up a continuous surface layer as with pure zinc coatings. As a result, no thickness

or weight loss is observed even after several years of exposure in atmospheric field testing.

4.7.4.3 Zinc-Iron Alloy Coatings

Compared with pure zinc coatings, the zinc-iron alloy coatings provide increased corrosion resistance in acidic atmospheres but slightly reduced corrosion resistance in alkaline atmospheres.

4.7.4.4 Cast Zinc Alloys

All the zinc-rich aluminum (ZA) alloys with an 8 to 29% aluminum content corrode less than 99.99% zinc. ZA-4 (zinc-4% aluminum) castings resist atmospheric corrosion in much the same manner as pure zinc. One advantage is that more zinc may be lost than with zinc coatings without affecting the performance.

In general, corrosion resistance is improved by the addition of higher amounts of aluminum. While ZA-8 (zinc-8% aluminum) and ZA-12 (zinc-12% aluminum) exhibit only modest improvements over the standard 4% alloy, ZA-27 (zinc-27% aluminum) with its significantly larger amount of aluminum-rich phase is much superior.

In plant atmospheres contaminated with either acidic or alkaline fumes, the ZA alloys perform better than pure zinc; whereas in alkaline-contaminated atmospheres, both zinc and the ZA alloys are more suitable than aluminum.

The addition of copper to zinc provides a slight improvement in corrosion resistance.

4.7.5 Copper

For centuries, copper has been used as an architectural material. Copper roofs are still in existence on many castles and monumental buildings that are hundreds of years old.

When exposed to the atmosphere over long periods of time, copper forms a coloration on the surface known as patina, which in reality is a corrosion product that acts as a protective film against further corrosion. The length of time required to form the patina depends on the atmosphere because the color is due to the formation of copper hydroxide compounds. Initially the patina has a dark color, which gradually turns green. This is also known as verdigras, which is French for green-gray. In urban or industrial atmospheres, the compound is a mixture of copper/hydroxide/sulfate and in marine atmospheres a mixture of copper/hydroxide/chloride. It takes approximately 7 years for these compounds to form. When exposed to clean or rural atmospheres, tens or hundreds of years might be required to form the patina, or protective film.

To be classified as copper, the compound must contain a minimum of 99.9% copper. Elements such as silver, arsenic, antimony, phosphorus, tellurium, nickel, cadmium, lead, sulfur, zirconium, magnesium, boron, and bismuth may be present singularly or in combination.

Copper is noble to hydrogen in the electromotive force (emf) series and thermodynamically stable with no tendency to erode in water and in non-oxidizing acids free of oxygen. With copper and its alloys, the predominant cathode reaction is the reduction of oxygen to form hydroxide ions. Therefore, the presence of oxygen or other oxidizing agents is necessary for corrosion to take place.

The coating of corrosion products forming the so-called patina has a complex composition that varies from one location to another. Primary components are generally copper oxide and one or more basic copper salts:

Basic sulfate: $\text{Cu(OH)}_{1.5}(\text{SO}_4)_{0.25}$, $\text{Cu(OH)}_{1.33}(\text{SO}_4)_{0.33}$

Basic chloride: $\text{Cu(OH)}_{1.5}\text{Cl}_{0.5}$

Basic carbonate: $\text{CuOH}(\text{CO}_3)_{0.5}$, $\text{Cu(OH)}_{1.33}(\text{CO}_3)_{0.33}$, $\text{CuOH}_{0.67}(\text{CO}_3)_{0.6}$

Basic nitrate: $\text{Cu(OH)}_{1.5}(\text{NO}_3)_{0.5}$

Basic sulfate is predominant in urban atmospheres and basic chloride in marine atmospheres, whereas in rural atmospheres the primary ingredient is usually basic sulfate. At times, basic carbonate is found. The presence of basic copper nitrate indicates that the water film on the metal surface contains appreciable amounts of nitrate.

In most cases, the first products formed are Cu_2O and CuO . These copper oxides react slowly with pollutants in the air such as SO_x , Cl^- , CO_2 , and NO_2 forming the basic salts. For this reaction to proceed, the pH value of the surface moisture must be sufficiently high:

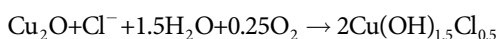
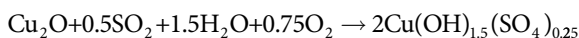

Corrosion rates for copper in various atmospheres have been determined as follows:

Atmosphere	Corrosion Rate ($\mu\text{m}/\text{yr}$)
Rural	1
Urban and industrial	1–3
Marine	1–2

The low corrosion rate and interesting patina formation of copper have been responsible for its use in building structures such as roofs, facades, and gutters. The blue-green patina forms after several years when conditions are favorable in outdoor atmospheres. Initially it may take on a mottled appearance but after 6 to 12 months, the surface usually turns a uniform dark brown color and remains as such for several years. It can take 5 to 10 yr before a green patina begins to appear on sloping surfaces in urban or marine atmospheres. Because vertical surfaces have a much shorter time of wetness, they remain black much longer. In a marine atmosphere, the surface facing the sea acquires a green patina sooner than the other surface as a result of a greater supply of chlorides from the sea winds.

In areas of very low pollution, the patina could conceivably take hundreds of years to form because of the small supply of anions to form the copper salt. When the temperature is very low or the exposure conditions are very dry, the patina may not form at all.

Under acidic conditions, the green patina will not form. Such conditions can occur near chimneys where acid smoke strikes the roof. Under these conditions, the corrosion products are soluble.

Traces of dissolved copper will usually be found in rainwater running off of copper-bearing surfaces. This takes place predominately in urban and industrial areas that are highly polluted with SO_2 . Such rainwater can cause blue staining on masonry, stonework, etc.

4.7.6 Copper Alloys

To increase the strength and general usefulness of copper, it is alloyed with other elements such as zinc, aluminum, nickel, tin, silicon, etc. The various alloy families are as follows:

Principal Alloying Element	Alloy Family
Zinc	Brasses
Tin, aluminum, or silicon	Bronzes
Nickel	Copper nickels

There are other alloy families but these are of little importance in the field of corrosion resistance and will not be discussed.

4.7.6.1 Brasses

Brasses contain zinc as their principal alloying ingredient. Other alloying ingredients include lead, tin, and aluminum. Lead is added to improve machinability and not to improve corrosion resistance. The addition of approximately 1% tin increases the de-alloying resistance of the alloys. Aluminum is

added to stabilize the protective surface film. Alloys containing in excess of 15% zinc are susceptible to de-alloying in acid or alkaline environments.

There is a type of corrosion in which brass dissolves as an alloy and the copper constituent redeposits from solution onto the surface of the brass as a metal in porous form. The zinc constituent may be deposited in place of an insoluble compound or carried away from the brass as a soluble salt. The corrosion can take place uniformly or locally. Uniform corrosion is more likely to take place in acidic environments, while local corrosion is more apt to take place in alkaline, neutral, or slightly acidic environments. The addition of tin or arsenic will inhibit this form of corrosion. Conditions of the environment that favor dezincification are high temperature, stagnant solutions (especially of acid), and porous inorganic scale formation. Other factors that stimulate the process are increasing zinc concentrations, and the presence of both cuprous and chloride ions. As the de-alloying proceeds, a porous layer of almost pure copper is left behind. This reaction layer is of poor mechanical strength. The dezincification process on copper-zinc alloys is therefore very detrimental.

High-zinc brasses are also susceptible to season cracking, which is a form of stress cracking. The term originates from early in the twentieth century when cartridge shells made of 70% copper and 30% zinc were found to crack over a period of time. It was later realized that ammonia from decaying organic matter in combination with residual stresses in the brass was responsible for the cracking of these shells. This phenomenon was called season cracking because the presence of high humidity during warm, moist climates (or seasons) promoted the stress corrosion cracking.

Stress corrosion of brass commonly occurs when brass is subjected to an applied or residual stress or while in contact with a trace of ammonia or amine in the presence of moisture and oxygen. The risk of stress corrosion cracking in brasses is greatest in industrial and urban atmospheres, characterized by high contents of sulfur dioxide and ammonia. The stress corrosion susceptibility is markedly lower in marine atmospheres. The relative resistance to stress corrosion cracking of the brasses is as follows:

- Low resistance:
 - Brasses containing more than 15% zinc
 - Brasses containing more than 15% zinc and small amounts of lead, tin, or aluminum
- Intermediate resistance:
 - Brasses containing less than 15% zinc

The admiralty and the naval brasses are resistant to de-alloying as a result of the addition of tin. High-zinc brasses resist sulfides better than low-zinc brasses.

Alloys containing 15% or less zinc resist de-alloying and are generally more resistant to stress corrosion cracking than the high-zinc alloys. Red brass is a typical alloy of this group; it contains 15% zinc. Dissolved air, oxidizing materials, and compounds that form copper complexes (e.g., ammonia) are corrosive to the low-zinc brasses.

4.7.6.2 *Bronzes*

Copper-tin alloys are known as tin bronzes or phosphor bronzes. Phosphorus is always present in small amounts even though tin is the principal alloying ingredient. Phosphorus is used as an oxidizer and generally has a concentration of less than 0.5%

These alloys date back to the Bronze Age and probably are the oldest alloys known. Many of the artifacts produced during the Bronze Age are still in existence. Items such as bells, statues, vases, and swords have survived hundreds of years of exposure to a wide variety of environments, proving the corrosion resistance of these materials.

Copper-aluminum alloys are known as aluminum bronzes. They are complex alloys containing iron, nickel, silicon, manganese, and other elements as well as aluminum.

As with copper, the aluminum bronzes find many architectural applications. A special aluminum bronze alloy designated C-61500 has been specifically developed for architectural use. It is reported to have a film resistance 20 times that of copper C-11000. These are suitable for marine atmospheres.

4.7.6.3 *Copper-Nickel Alloys*

The copper-nickel alloys are referred to as cupronickels and have nickel as the principal alloying ingredient. Of all the copper alloys, the cupronickels are the most resistant to stress corrosion cracking in ammonia and ammoniacal environments. These alloys do not find many applications to resist atmospheric corrosion because of their cost. They would be most suitable for marine atmospheres.

4.7.7 *Aluminum Alloys*

The resistance to atmospheric corrosion of aluminum is due to the rapid formation of a thin, compact, adherent oxide film over the surface that limits corrosion. This surface film, when formed in air, is approximately 10 to 20 nm thick. It is thicker when formed in the presence of water or water vapor. This oxide film is stable (insoluble) in the pH range of approximately 4 to 9, which includes many atmospheric environments.

Pourbaix potential-pH diagrams can be used to predict the regions of oxide stability and of uniform corrosion in atmospheric types, as shown in Figure 4.3. Note that aluminum is thermodynamically stable only at low

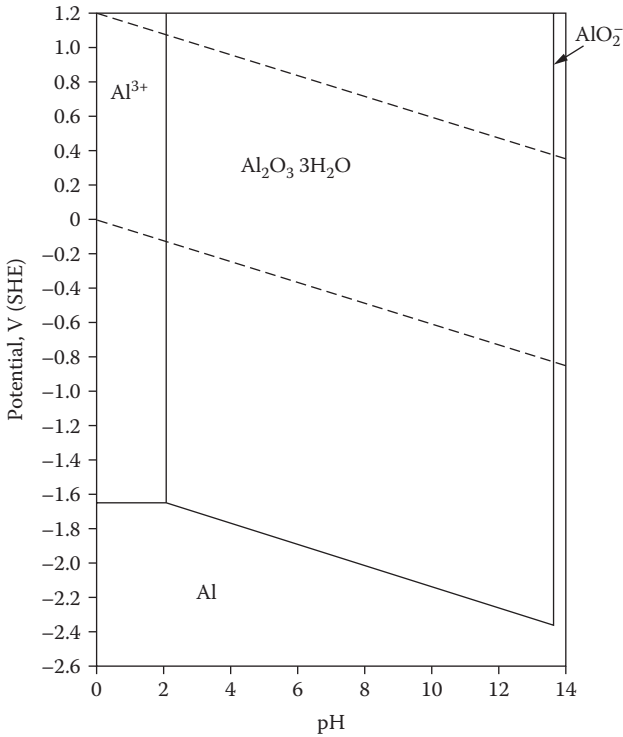

FIGURE 4.3 Potential-pH diagram, Al-H₂O; 25°C, 10⁻¹ MAI. (Source: From Reference 6.)

potentials. Because of its property of developing a protective coating of alumina, it can be used in the presence of water. At an Al³⁺ activity of 10⁻¹ μ, the stability range of the oxide extends down to pH 2.5.

Corrosion products that form during the outdoor corrosion of aluminum are amorphous Al(OH)₃, or ∞-Al(OH)₃ (bayerite), and γ-Al₂O₃, the latter with varying amounts of water in the lattice.

A 10- to 20-mm thick amorphous oxide protective coating forms when a fresh aluminum surface is exposed to dry air. In a moist atmosphere, the oxide coating will thicken. The coating consists of one dense, protective barrier layer next to the metal and an outer, more permeable bulk layer.

Water-soluble salts such as Al₂(SO₄)₃ may be formed when anions (e.g., SO₄²⁻ and Cl⁻) are deposited on the oxide surface and react with the oxide film. They may also be incorporated into the lattice to form a variety of basic salts and complexes.

In urban atmospheres, the oxide coating is protective against SO₂ pollution, producing a relatively low pH value in the moisture film. If high SO₂ pollution exists, a very low pH value of the moisture film is produced, which leads to the dissolution of the protective film.

In the presence of chloride ions, pitting may be initiated. It is believed that the chloride ions migrate to the oxide layer and lower its resistance to outward migration of Al^{3+} . During the propagation stage, aluminum is dissolved anodically to Al^{3+} ions within the pit. A cathodic reaction takes place either inside the pit, close to the mouth, or outside the pit and consists of the reduction of oxygen or H^+ ions. The passivating oxide layer has low electronic conductivity but the cathode reaction may locally destroy the protective oxide layer due to alkalization. This lowers the electrode potential and may even make hydrogen liberation possible. Acid conditions are created within the pit by hydrolysis of the Al^{3+} ions, and a cap of $\text{Al}(\text{OH})_3$ and/or Al_2O_3 forms over the mouth of the pit. The corrosion products finally block the operation of the pit.

Aluminum retains its shiny appearance for years in clean outdoor atmospheres. Small pits, which are barely visible to the naked eye, develop in polluted outdoor atmospheres. These pits become covered with crusts of aluminum oxide and aluminum hydroxide. During the first few years of exposure, the growth rate of the maximum pit depth is relatively high. This growth rate decreases gradually, so that the pit depth approaches a nearly constant value (see Figure 4.4).

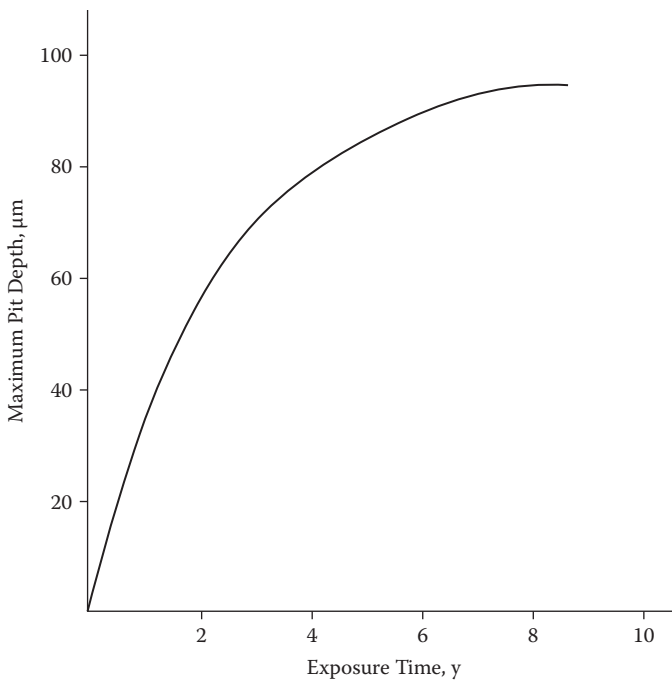

FIGURE 4.4

Maximum pit depth vs. exposure time for Al Mn 1.2 in an urban atmosphere.

The corrosion resistance of aluminum is reduced by most alloying constituents in clean or slightly polluted atmospheres. Urban or industrial atmospheres are those atmospheres that are high in CO and CO₂, sulfates and sulfites, and possibly various N_xO gases. The corrosion rate is largely the same for unalloyed aluminum as with most conventional aluminum alloys (alloys with zinc, magnesium, silicon, and/or manganese). Aluminum alloys with copper will exhibit corrosion rates 4 to 20 times higher. When the SO₂ concentration is less than 0.01% by volume, the atmospheric corrosion rate even at a relative humidity of 98% is negligibly affected by the presence of SO₂. This is probably due to the low adsorption tendency for SO₂ on aluminum surfaces. When the SO₂ concentration exceeds 0.01% by volume, severe corrosion effects occur.

Some highly urban areas, such as the greater Chicago area, have been found to cause exfoliation, whereas other cities such as Los Angeles, which have high N_xO gases, are capable of causing increased susceptibility to stress corrosion cracking. However, in general, most urban/industrial areas do not cause exfoliation and the need for protection is to:

1. Retain aesthetic appearance
2. Prevent pitting formation of their parts
3. Avoid failure by stress corrosion cracking

The aesthetic problem of discoloration can be caused by excessive smoke emissions. That was a major problem before regulations on smoke emissions were enacted. The discoloration problem is not limited to aluminum; it also occurs on other metals, masonry, and stone.

Practically all the aluminum alloys, at least with appropriate protective measures, will provide satisfactory corrosion resistance in urban/industrial areas. Consequently, the choice of alloy can be based on other engineering considerations.

The most damaging natural atmosphere for aluminum is that of a seacoast, with the severest corrosion taking place within 0.5 mi (0.8 km) of the shoreline. Corrosive effects will be greatly reduced at distances of 2 to 5 miles (3 to 8 km) from the shore. Prevailing wind directions and the roughness of the surf determine the extent of the corrosive effect, and control how far inland actual salt mist will be carried. To maintain the shiny metallic surface of aluminum in a seacoast atmosphere, pure aluminum as well as some aluminum alloys must be protected with a coat of clear lacquer or an anodized coating.

Alloys of the 2XXX and 7XXX with tempers that are susceptible to intergranular corrosion, exfoliation, or stress corrosion cracking should not be used in seacoast atmospheres. Thin products should be afforded protection against perforation even if they are only susceptible to pitting corrosion.

For alloys whose tempers are resistant to exfoliation and stress corrosion cracking, the need for protection depends on two factors:

1. The desire to retain a pleasing appearance
2. Whether the application is fatigue-critical (if so, the depth of pitting corrosion might cause sufficient stress to initiate a crack)

Structural products about 12 mm or more in thickness that are used for nonfatigue-critical structural applications will darken and have the surface stained as a result of weathering. Pitting corrosion will roughen the surface to a maximum depth of approximately 0.15 mm. However, the loss in residual tensile strength and load-carrying ability will be negligible.

The higher strength alloys such as 5XXX and 6XXX do not require any preventative coating because they have sufficient inherent corrosion resistance. These alloys will darken and their surface will undergo a slight roughening but they are capable of surviving 20 or more years of exposure without appreciable degradation.

Until recently, rural atmospheres were considered noncorrosive to aluminum alloys. However, airborne pollution from coal-burning power plants located upwind have produced an acid rain that falls over a widespread area. This has resulted in staining and darkening of the aluminum surfaces but has not resulted in more severe forms of corrosion. Acid rainfalls in rural areas have caused greater corrosion problems on steel than on aluminum.

4.7.7.1 Protective Measures

Proper design of the product along with the selection of the proper alloy are the first steps that should be taken toward protection of the finished product. When necessary, there are various coatings that can be applied.

Anodic coatings. It is possible to apply an anodic coating to aluminum alloy products. The coating can be a spray coating of zinc, pure aluminum, or a more anodic aluminum alloy.

Alclad coatings. Alclad coatings consist of a metallurgical bond between two pure aluminum sheets forming a sandwich on either side of an aluminum alloy sheet, which is referred to as the core. The cladding process provides a barrier layer of a more resistant material than the core. Should the barrier layer become damaged by inadvertent dings or scratches, or accidentally penetrated by drilling or sawing, or if natural pitting corrosion of the cladding reaches the core, the electrochemical nature of the cladding takes over. Any further corrosion spreads laterally, confining itself to the cladding rather than penetrating the core. Cladding is one of the few surface protection methods that provides effective protection even when a break or flaw exists in the coating.

Barrier coatings. Barrier coatings are of two types. The first consists of a thin surface layer of a more resistant metal. This can be accomplished by

roll bonding (e.g., stainless steel to non-heat-treatable aluminum alloys), by chrome plating, or by vapor deposition or ion deposition of a variety of metals. The latter methods are expensive and have size limitations. Unlike Alclad coatings, metal barrier coatings do not provide any electrochemical protection at a break in the coating.

Conversion coatings and paint coatings are the more conventional barrier coatings.

Anodized coatings. Anodized coatings are produced by an electrolyte process. The surface of the aluminum is immersed in an acidic bath and made the anode, and a direct current is applied. Oxidation of the surface produces a hard, porous film of aluminum oxide that is bound as tenaciously to the alloy as the natural oxide film but is much thicker. Most anodized coatings are produced using either a sulfuric acid, chromic acid, or phosphoric acid bath. Other solutions can also be used (e.g., boric acid, oxalic acid). The porous oxide film is sealed by immersion in boiling water, which imparts impermeability to the film. The porous film may be dyed to impart color before sealing.

The anodized surfaces are shinier and more wear resistant than the natural oxide surface and are easier to keep clean. Eventually they will wear or roughen through use. The primary attributes of anodizing are in decorative appearance and ease of cleaning.

Anodized coatings are not resistant in most environments having a pH outside the range of 4 to 9. Within this range, the corrosion resistance is improved by an order of magnitude or more. Atmospheric weather tests show that the number of pits that develop in the base metal decrease exponentially with the thickness of the coating. As a general rule, anodized coatings do not provide sufficient protection to make aluminum alloys suitable for environments where without the coatings, the alloys themselves are unsuitable because of their poor resistance in them.

Anodized surfaces are excellent for subsequent painting but usually less expensive treatments are used for this purpose.

Paints. Aluminum is painted for both decorative and protective purposes. As with any metal, surface preparation is extremely important. Conversion coatings, either of the chromate or phosphate type, are recommended for the preparation of aluminum alloys. In environments containing chlorides, a chromated primer should be applied first. Water-based paints are particularly suitable for use with aluminum alloys.

4.7.7.2 Applications

Aluminum and aluminum alloys find applications in such outdoor atmospheres as roofing, building facades, and window frames. They are particularly useful in SO₂-polluted atmospheres because of their relatively good resistance. After decades of exposure, aluminum structures in urban atmospheres have been reported to be in excellent condition.

The shiny metal appearance will gradually disappear and the surface will roughen under the formation of a gray patina of corrosion products. If soot is present in the atmosphere, it will be absorbed by the corrosion products and give the patina a dark color. If the surface has been anodized, the shiny metal appearance will be retained. Except in highly polluted atmospheres, the low penetration rate and shallow pitting do not usually affect the mechanical properties of the aluminum.

Dust and other pollutants may collect in rain-sheltered positions and accelerate corrosion by disturbing the formation of a protective oxide coating. These rain-sheltered areas will often show staining as a result of the corrosion. When possible, these rain-sheltered areas should be eliminated during the design stage.

Aluminum and its alloys are also suitable for use in marine atmospheres. Care must be taken in the design because under these conditions, the aluminum is susceptible to bimetallic corrosion when in contact with copper or carbon steel. If the chloride concentration is high, the aluminum may be susceptible to crevice corrosion.

4.7.8 Stainless Steel

Stainless steel is probably the most widely known material that is used for corrosion resistance. However, stainless steel is not a singular material as the name might imply, but rather a broad group of alloys each of which exhibits its own physical and corrosion-resistant properties.

Stainless steels are alloys of iron to which a minimum of 11% chromium has been added to provide a passive film to resist rusting when the material is exposed to the weather. The film is self-forming and self-healing in environments where the stainless steel is resistant. Improved corrosion resistance is achieved as more chromium is added to the alloy. Consequently, there are stainless steels with chromium contents of 15%, 17%, 20%, and higher. Other ingredients are added to further improve corrosion resistance and mechanical strength.

As a result of these alloying possibilities, more than 70 stainless steels are available. They can be divided into four major categories depending on their microstructure:

1. Austenitic
2. Ferritic
3. Martensitic
4. Duplex

Resistance to atmospheric corrosion was one of the earliest characteristics of the chromium-bearing alloys. When compared to iron and steel, their resistance prompted the name "stainless."

Although atmospheric corrosion of ferrous metals is related first to the amount of moisture in the air (relative humidity), atmospheric moisture alone has no influence on the corrosion of stainless steel. Of primary importance are the effects of such atmospheric contaminants as particulate chlorides and iron-based dust. Sulfur-based acids will promote corrosion while oxides of nitrogen improve the resistance. Contaminants such as hydrocarbons, ammonia, and the oxides of carbon have no effect.

4.7.8.1 Austenitic Grades

Of all the stainless steels, the austenitic grades are the most widely used for corrosion resistance. By adding substantial quantities of nickel to high-chromium alloys, the austenite is stabilized at room temperature. This group of alloys contains 16 to 26% chromium and 6 to 22% nickel, while the carbon content is kept low (0.08%) to minimize carbide precipitation. The types of stainless steels that make up the austenitic group are as follows:

201	304N	316SF	20Cb3
202	305N	316L	904L
205	308	316N	20Mo4
301	309	317L	20Mo6
302	309S	317LN	Al-6XN
302B	310N	321	25-6Mo
303	310S	330	Alloy 31
304	314S	347	Alloy 654
304L	316	348	

The corrosion resistance of the austenitic stainless steels is the result of the formation of an oxide film on the surface of the metal. Consequently, they perform best under oxidizing conditions. Reducing conditions and chloride ions destroy the film by causing rapid attack.

Types 304 and 304L stainless steels are normally used in atmospheric exposures. In industrial or marine environments, types 316 and 316L are usually selected because of their greater resistance to chloride contamination as a result of the addition of molybdenum.

Any of the austenitic stainless steels can be used in rural or other uncontaminated atmospheres. Under these conditions, they will serve indefinitely without changes in appearance or losses in strength, even if the relative humidity approaches 100%. Selections for such applications would be based on cost, availability in the sizes and shapes required, mechanical properties, ease of fabrication, and appearance.

In industrial or marine atmospheres, or from contamination with highway de-icing salts, chloride pitting may occur. If the contamination is severe, overall rusting can occur rather than localized pitting.

Design of the installation in an industrial atmosphere is important. If the stainless steel is partly sheltered so that deposits are not washed away by rain, and the deposits are hygroscopic and corrosive, some attack may take place that should not otherwise be encountered. In tests, exposed specimens were virtually unattacked, whereas for specimens in a sheltered location under a roof, only those containing molybdenum (types 316 and 316L) remained unattacked.

In marine atmospheres, types 304 and 304L stainless steels may develop substantial staining in the form of scattered patches of yellow-brown films. There is little evidence of attack beneath the films. The discoloration will develop during the first few months of exposure, after which it does not appear to develop further. Even after exposure of 10 yr or more, the stain may easily be removed, revealing a bright surface with little evidence of attack. If the staining is unacceptable, a more highly alloyed stainless steel such as type 309 will evidence a greatly reduced amount of staining. The use of type 316 will practically eliminate all staining.

As the distance from the shoreline increases, the intensity of the staining will decrease. However, the type 316 alloy remains free from staining for long periods of time even when exposed as close as 80 ft from the shoreline.

Any of the austenitic stainless steels can be used in a marine atmosphere if they are cleaned periodically. If cleaning is not practical, then type 316 alloy will provide the greatest resistance to staining.

4.7.8.2 Ferritic Grades

The ferritic grades contain 15 to 30% chromium with a low carbon content (0.1%). Resistance to atmospheric corrosion of the ferritic grades will depend on the chromium content as well as the condition of exposure.

Types 405 and 409 have approximately the same resistance to chloride pitting as type 410, whereas higher alloyed types such as 430 are more resistant.

Rural atmospheres are less corrosive to the ferritic grades than marine atmospheres, while the corrosiveness of industrial atmospheres depends on the nature of the contaminants.

Type 430 will rust in a sheltered location when exposed to an industrial atmosphere. If exposed to washing by rain, the rusting can be reduced or eliminated.

4.7.8.3 Martensitic Grades

The martensitic grades normally contain 11 to 13% chromium. Martensite has a body-centered tetragonal structure that provides increased strength vs. the annealed stainlesses with other lattice structures. Sufficient carbon is added

to permit martensite formation with rapid cooling. Other elements such as nickel or molybdenum may be added for improved corrosion resistance.

The corrosion resistance of the martensitic stainless steels is inferior to that of the austenitic steels. These alloys are usually used in mildly corrosive applications such as atmospheric.

Alloy 17-7PH is a semi-austenitic stainless steel. In annealed condition, it is austenitic but in the aged condition, it is martensitic.

In rural and mild industrial atmospheres, it has excellent resistance to general corrosion, being equivalent to type 304 stainless steel. In marine atmospheres, alloy 17-7PH will gradually develop a slight rusting and pitting in all heat-treated conditions. It is almost equal to type 304 in these applications.

4.7.8.4 Duplex Grades

The duplex stainless steels are alloys whose microstructures are a mixture of austenite and ferrite. Type 32550 and related alloys containing molybdenum have an atmospheric corrosion resistance superior to type 316 in high-chloride environments. The duplex grade would be used when the greater strength of these alloys is required for application in a marine atmosphere.

4.7.9 Nickel

Nickel outdoors becomes dull and acquires a thin adherent corrosion-resistant film that is usually a sulfate. The rate of corrosion is extremely slow; however, the rate increases with an increase in the sulfur dioxide content of the atmosphere. Nickel 200 has a very low corrosion rate in both rural and marine atmospheres.

4.7.10 Monel Alloy

Monel is a nickel alloy containing 30 to 33% copper. The corrosion of monel is negligible in all types of atmospheres. When exposed to rain, a thin gray-green patina develops. In a sulfurous atmosphere, a smooth brown adherent film forms. Because of its low corrosion rate and the pleasant patina that forms, Monel 400 is used for architectural applications such as roofs, gutters, and flashings.

4.7.11 Inconel Alloy 600

Inconel 600 is a nickel-chromium-iron alloy having approximately 16.0% chromium and 7.0% iron. In rural atmospheres, the alloy remains bright for many years. When exposed to an industrial atmosphere containing sulfur, a slight tarnish may develop. It is preferable for Inconel 600 to be exposed to the atmosphere rather than be sheltered. This will permit rain to wash the surface, and the sun and wind to dry the surface.

4.7.12 Inconel Alloy 625, Incoloy Alloy 800, Incoloy Alloy 825

Inconel alloy 625 is a nickel-chromium-molybdenum-columbium alloy, Incoloy 800 is a chromium-nickel-iron alloy, and Incoloy 825 is a chromium-nickel-iron alloy similar to alloy 800 but having a higher nickel content. These alloys remain bright and tarnish-free in rural and industrial atmospheres. Alloy 800 develops a very thin oxide film after prolonged exposure in marine atmospheres, whereas alloys 625 and 825 remain bright.

4.8 Atmospheric Corrosion of Nonmetals

Atmospheric corrosion has been defined as an electrochemical reaction requiring the presence of an electrolyte. This is true of a metallic material. However, there are other materials of construction that do not corrode by electrochemical mechanisms. Among these are such materials as plastics, elastomers, masonry materials, ceramics, and wood.

4.8.1 Plastics

Plastics are, in reality, polymers. The term “plastics” is defined in the dictionary as “capable of being easily molded,” such as putty or clay. The term “plastics” was originally adopted to describe early polymeric materials because they could be easily molded. Unfortunately, many of today’s polymers are quite brittle and once formed cannot be molded.

There are two distinct groups of plastics: the thermoplasts and the thermosets. The thermoplasts can be melted, cooled, and remelted without destroying the physical or mechanical properties of the polymer. The thermosets begin as a powder or liquid that is reacted with a second material, or which through catalyzed polymerization results in a new product that has properties differing from those of either starting material.

Polymeric materials in outdoor applications are exposed to weather extremes that can be deleterious to the material. The most harmful weather component, exposure to UV radiation, can cause embrittlement, fading, surface cracking, and chalking. Most plastics, after being exposed to direct sunlight for a period of years, exhibit reduced impact resistance, lower overall mechanical performance, and a change in appearance.

The electromagnetic energy from sunlight is normally divided into ultraviolet (UV) light, visible (VIS) light, and infrared (IR) energy. IR energy consists of wavelengths longer than the VIS red wavelengths and starts above 760 nm. VIS light is defined as radiation between 400 and 760 nm. UV light consists of radiation below 400 nm. The UV portion of the spectrum is further

TABLE 4.6

Wavelength Regions of the UV

Region	Wavelength (nm)	Characteristics
UV-A	400–315	Causes polymer damage
UV-B	315–280	Includes the shortest wavelengths at the Earth's surface Causes severe polymer damage Absorbed by window glass
UV-C	280–100	Filtered by Earth's atmosphere Found only in outer space

Source: From Reference 7.

divided into UV-A, UV-B, and UV-C. The effects of the various wavelength regions are shown in Table 4.6.

Because UV is easily filtered by air masses, cloud cover, pollution, and other factors, the amount and spectrum of natural UV exposure is extremely variable. Because the sun is lower in the sky during the winter months, it is filtered through a greater air mass. This creates two important differences between summer and winter sunlight: changes in the intensity of the light and in the spectrum. During the winter months, much of the damaging short-wavelength UV light is filtered out. For example, the intensity of UV at 320 nm changes by about 8 to 1 from summer to winter. In addition, the short-wavelength solar cutoff shifts from about 295 nm in summer to about 310 nm in winter. As a result, materials sensitive to UV below 320 nm would degrade only slightly, if at all, during the winter months.

Photochemical degradation is caused by photons of light breaking chemical bonds. For each type of chemical bond, there is a critical threshold wavelength of light with enough energy to cause a reaction. Light of any wavelength shorter than the threshold can break the bond, but longer wavelengths of light cannot break it regardless of their intensity (brightness). Therefore, the short-wavelength cutoff of a light source is of critical importance. If a particular polymer is sensitive only to UV light below 295 nm (the solar cutoff point), it will never experience photochemical degradation outdoors.

The ability to withstand weathering varies with the polymer type and with the grade of the particular resin. Most resin grades are available with UV-absorbing additives to improve weatherability. However, the higher-molecular-weight grades of a resin generally exhibit better weatherability than lower-molecular-weight grades with comparable additives. In addition, some colors tend to weather better than others.

4.8.1.1 Thermoplastics

The periodic table provides a means whereby the general differences in the corrosion resistance of the thermoplasts can be determined. In the periodic

table, the basic elements of nature are placed into classes with similar properties, that is, elements and compounds that exhibit similar behavior. These classes are alkali metals, alkaline earth metals, transition metals, rare earth series, nonmetals, and noble (inert) gases.

Of particular importance and interest, in the case of thermoplasts, is the category known as halogens. The elements included in this category are fluorine, bromine, chlorine, and iodine. Because these are the most electronegative elements in the periodic table, they are the most likely to attract an electron from another element and become a stable structure. Of all the halogens, fluorine is the most electronegative, permitting it to bond strongly with carbon and hydrogen atoms, but not well with itself. The carbon–fluorine bond is predominant in polyvinylidene fluoride (PVDF) and is responsible for the important properties of these materials. These are among the strongest known organic compounds. The fluorine acts as a protective shield for other bonds of lesser strength within the main chain of the polymer. The carbon–hydrogen bond, of which such plastics as polyethylene (PE) and polypropylene (PP) are composed, is considerably weaker. The carbon–chlorine bond, a key bond in polyvinyl chloride (PVC), is still weaker.

The arrangement of the elements in the molecule, the symmetry of the structure, and the degree of branching of the polymer chains are as important as the specific elements contained in the molecule. Plastics containing carbon–hydrogen bonds (such as PE and PP) and the carbon–chlorine bonds (such as PVC, ethylenechlorotrifluoroethylene (ECTFE), and chlorotrifluoroethylene (CTFE)) are different in the important property of chemical resistance from a fully fluorinated plastic such as polytetrafluoroethylene (PTFE). Table 4.7 lists the abbreviations used for the thermoplasts. In considering these polymers for outdoor use, the surrounding atmospheric temperatures must be considered, as well as the operating temperatures. Certain geographic areas may have ambient temperatures at times that will be outside the allowable range of some of the polymers. Table 4.8 provides the allowable operating temperatures for the basic polymers.

It must be remembered that all thermoplastic polymers are compounded and in many instances other materials are added to enhance specific properties. In almost all cases, this enhancement of a specific property results in a corresponding reduction in another property. One of the properties most often affected is that of corrosion resistance. Consequently, care must be exercised in specifying thermoplastic polymers. Check with the manufacturer to verify the specific application.

Table 4.9 lists the atmospheric resistance of the basic polymers. Some additives enhance resistance to atmospheric corrosion, resulting in enhanced protection from UV degradation and increased moisture resistance.

TABLE 4.7
Abbreviations Used for Thermoplasts

Abbreviation	Thermoplast
ABS	Acrylonitrile-butadiene-styrene
CPVC	Chlorinated polyvinyl chloride
CTFE	Chlorotrifluorethylene
ECTFE	Ethylene chlorotrifluorethylene
ETFE	Ethylene tetrafluorethylene
FEP	Fluorinated ethylene propylene
HDPE	High-density polyethylene
PA	Polyamide
PAI	Polyamideimide
PB	Polybutylene
PC	Polycarbonate
PCTFE	Polychlorotrifluorethylene
PE	Polyethylene
PEEK	Polyetheretherketone
PEI	Polyetherimide
PEK	Polyetherketone
PES	Polyethersulfone
PF	Phenol formaldehyde
PFA	Polyfluoralkoxy
PI	Polyimide
PP	Polypropylene
PPS	Polyphenylene sulfide
PSF	Polysulfone
PTFE	Polytetrafluorethylene
PVC	Polyvinyl chloride
PVDC	Polyvinylidene chloride
PVDF	Polyvinylidene fluoride
UHMWPE	Ultrahigh-molecular-weight polyethylene

Source: From Reference 8.

4.8.1.2 Thermosets

Thermosets, or thermosetting polymers, are derived from low-molecular-weight precursors known as monomers or oligomers. When allowed to polymerize (chemically react), they form continuous network polymers of very large molecular weights that are crosslinked to the extent that the network is infusible and insoluble.

TABLE 4.8

Allowable Temperature Ranges of Thermoplastic Polymers

Polymer	Allowable Temp. (°F/°C)	
	Minimum	Maximum
ABS	-40/-40	140/60
CPVC	0/-18	180/82
ECTFE	-105/-76	340/171
ETFE	-370/-223	300/149
FEP	-50/-45	400/205
HDPE	-60/-51	180/82
PA	-60/-51	300/149
PAI	<-310/<-190	500/260
PB	—	200/93
PC	-200/-129	250-275/120-135
PCTFE	-105/-76	380/190
PEEK	-85/-65	480/250
PEI	<-310/<-190	500/260
PES	—	340/170
PFA	-310/-190	500/260
PI	<-310/<-190	500-600/260-315
PP	32/0	215/102
PPS	—	450/230
PSF	-150/-101	300/149
PTFE	-20/-29	500/260
PVC	0/-18	140/60
PVDC	0/-18	175/80
PVDF	-50/-45	320/160
UHMWPE	40/4	200/93

Note: Temperature limits may have to be modified, depending on the corrodent if in direct contact.

Source: From Reference 9.

Because of the need for strength in structural applications, thermoset polymers are usually used with fiber reinforcement, the most common of which is fiberglass. Because there are now several different materials forming the composite, degradation of the composite can be complex because each material can degrade separately or simultaneously. In addition, there are concerns about the degradation of the interface between the polymer and the reinforcement.

Cure plays an important part in the corrosion resistance of a thermoset polymer, as does the construction of the laminate itself and the type of glass

TABLE 4.9

Atmospheric Resistance of Thermoplastic Polymers

Polymer	UV Degradation	Moisture Absorption ^a	Weathering	Ozone	SO ₂	NO _x	H ₂ S
ABS	RS	0.30	R	X	R ^b		R ^b
CPVC	R	0.03	R	R	R		R ^b
ECTFE	R	<0.1	R	R	R	R	R
ETFE	R	<0.029	R	R	R	R	R
FEP	R	<0.01	R	R	R	R	R
HDPE	RS		R	R	R		R
PA	R	0.6–1.2	R	X	R ^c		X
PC	RS	0.15	L	R			
PCTFE	R		R	R	R	R	R
PEEK	RS	0.50	L	R	R		R
PEI	R	0.25	R	R			
PES	RS				X		R
PF					R		R
PFA	R	<0.03	R	R	R	R	R
PI	R		R	R			
PP	RS	0.02	L	L	R	R	R
PPS	R	0.01	R		R		R ^b
PSF	R	0.30	R	R			
PTFE	R	<0.01	R	R	R	R	R
PVC	R	0.05	R	R	R ^d	X	R
PVDC	R		R	R	R	R	R
PVDF	R	<0.04	R	R	R	R	R
UHMWPE	RS	<0.01	R	R	R		R

Note: R = resistant; RS = resistant only if stabilized with a UV protector; X = not resistant; and L = limited resistance.

^a Water absorption rate 24 h at 73°F/23°C (%).

^b Dry only.

^c Wet only.

^d Type 1 only.

Source: From Reference 10.

or reinforcing material used. Certain environments may weaken primary and/or secondary polymer linkages, with resulting depolymerization. Other environments may cause swelling or microcracking, whereas still others may hydrolyze ester groupings or linkages. Extraction can occur in certain environments, while in other environments repolymerization can take place with a resulting change in structure. Simple solvent action may occur or absorption or attack at the interface between the glass and the resin will result in weakening. The mechanisms involved are complicated and not well understood.

Table 4.10 lists the operating temperature ranges of thermoset polymers and Table 4.11 provides the atmospheric resistance of the thermoset polymers.

TABLE 4.10

Operating Temperature Ranges of Thermoset Polymers

Polymer	Allowable Temp. (°F/°C)	
	Minimum	Maximum
Epoxy	-423/-252	300/150
Polyesters:		
Bisphenol A – fumarate		250–300/120–150
Halogenated		250–300/120–150
Hydrogenated bisphenol A – bisphenol A		250–300/120–150
Isophthalic		150/70
Terephthalic		250–300/120–150
Vinyl ester		200–280/98–140
Furan		300–400/150–200
Phenolic		230/110
Silicone	-423/-252	500/260

Note: Temperatures might have to be modified, depending on the corrodent.

Source: From Reference 11.

TABLE 4.11

Atmospheric Resistance of Fiberglass-Reinforced Thermoset Polymers

Polymer	UV Degradation	Moisture Absorption ^a	Weathering	Ozone	SO ₂	NO _x	H ₂ S
Epoxy	R	0.03	R	R	R	R	R
Polyesters:							
Bisphenol A – fumarate	RS	0.20	R	R	R	R	R
Halogenated	RS	0.20	R	R	R	R	R
Hydrogenated bisphenol A – bisphenol A	RS	0.20	R	R	R ^b	R	
Isophthalic	RS	0.20	R	R	R	R	R
Teraphthalic	RS	0.20	R	R	R	R	R
Vinyl ester	R	0.20	R	R	R	R	R
Furan	R	2.65	R	R	R	R	R
Phenolic			R				R
Silicone	R	0.02–0.06	R	R	R	R	

Note: R = resistant; RS = resistant only if stabilized with UV protector; and X = not resistant.

^a Water absorption rate 24 h at 73°F/23°C (%).

^b SO₃ will cause severe attack.

Source: Reference 12.

4.8.2 Elastomers

An elastomer is considered any material, either natural or synthetic, that is elastic or resilient, and in general resembles rubber in feeling and appearance. Basically, an elastomer is a rubber-like material that can be or already is modified to a state exhibiting little plastic flow and quick and nearly complete recovery from an extending force. These materials are sometimes referred to as rubbers. Before modification, an elastomer is referred to as a raw or crude rubber or a basic high polymer. Table 4.12 provides the ASTM designation of elastomers.

TABLE 4.12
ASTM Designation of Elastomers

ASTM Designation	Elastomer
ABR	Acrylate-butadiene
Butyl IIR	Butyl rubber; GR-1
XNBR	Carboxylic acrylonitrile-butadiene
FPM	Perfluoroelastomers; Chemraz ¹ ; Kalrez ¹
CIIR	Chlorobutyl rubber
EA	Ethylene-acrylic
ECTFE	Ethylene-chlorotrifluoroethylene; Halar ¹
EPDM	Ethylene-propylenediene; Nordel ¹
EPT	Ethylene-propylene terpolymer
FKM	Fluoroelastomers; Viton ¹ ; Fluorel ¹ ; Technoflon ¹
IR	Isoprene
NR	Natural rubber
Nitrile NBR	Buna N
BR	Polybutadiene
PE	Polyester; Hytrel ¹
EU	Polyether urethane
AU	Polyurethane
SBR-styrene	Buna S; styrene-butadiene rubber
CR	Polychloroprene; neoprene ¹
CSM	Chlorosulfonated polyethylene; Hypalon ¹
ACM	Acrylate ester-acrylic halide
SBS	Styrene-butadiene-styrene
SEBS	Styrene-ethylene-butylene-styrene rubber
TPE	Thermoplastic elastomer
SI	Silicone rubber
FSI	Fluorosilicone rubber
HFP	Vinylidene fluoride; PVDF
ETFE	Ethylene-tetrafluoroethylene
T	Polysulfide rubber

¹ Registered trademark

Source: From Reference 13.

Elastomers in outdoor use are exposed to the deteriorative agents mostly considered in the category, which are sunlight, heat, oxygen, stress with atmospheric ozone, atmospheric moisture, and atmospheric nitrous oxide. Table 4.13 provides the resistance of elastomers to atmospheric pollution. Crosslinkage or chain growth usually decreases elongation and increases hardness and tensile strength, whereas chain rupture will have the opposite effect. Some elastomers will continue to harden and some to soften, whereas others will show an initial hardening followed by softening. All are irreversible reactions.

The operating temperature ranges of the common elastomers are shown in Table 4.14. The low-temperature properties of an elastomer must also be taken into account when used in outdoor service. With many elastomers, crystallization takes place, at which time the elastomer is brittle and will fracture easily. Table 4.15 gives the relative low-temperature flexibility of the more common elastomers. Table 4.16 gives the brittle points of the common elastomers.

4.8.3 Masonry Materials

Concrete and cement-based products are widely used construction materials. The primary ingredient is Portland cement, which is also used to produce building block. Although concrete and all cement-based products are inherently weak in tension, they are strong in compression. To overcome the weakness in tension, steel rods (reinforcing rods) are placed in the uncured mix. The reinforcing steel can be plain, prestressed, or poststressed. Stressed steel places the concrete in compression (its strong point). Any tensile load placed on the structure must overcome the compressive load due to the prestressed steel before the concrete will be placed in the tensile load mode. Micro- and macrocracking of the concrete results from the weakness in tensile loading ability, which reduces the life expectancy in a corrosive environment. Corrosion gains access to the interior of the concrete through these cracks. If this results in the rusting of the embedded steel, then the volume of the excess iron oxide cannot be accommodated. Because of the poor tensile strength of the concrete, spalling of the cement mass will take place.

The resistance of concrete to corrosion is the result of its nonoxidizable structure (resistance to water and hydrogen). Steel that has been embedded in the mix is passivated as a result of the hardened materials' pH of 12.5. Concrete will resist degradation as long as nothing in the environment dissolves the cement matrix or reduces its ability to passivate the embedded steel.

The alkalinity of the concrete is provided by the presence of calcium oxide (lime). Any material that will cause the calcium oxide or hydroxide to be removed, thereby lowering the pH, will prove detrimental and cause solution of the cement hydrates. Organic acids can be generated when organic materials ferment.

When carbon dioxide dissolves in water that may be present on the concrete, weak carbonic acid is produced. The weak carbonic acid lowers the pH

TABLE 4.13

Resistance of Elastomers to Atmospheric Pollution

Elastomer	UV Degradation	Resistance to Water Absorption	Pollutant				
			Weathering	Ozone	SO ₂	NO _x	H ₂ S
NR, natural rubber	P	E	P	P	X		R ^b
IR, isoprene rubber	P	E	P	P	X		R ^b
CR, neoprene rubber	E	G	E	GE	X	X	R
SBR, Buna S	P	GE	P	P			
NBR, Buna N	P	FG	F	P	R ^a	X	R ^b
IIR, butyl rubber	G	G	E	E	R		R
CIIR, chlorobutyl	G	G	F	E			
CSM, Hypalon	E	GE	E	E	X	X	R
BR, polybutadiene	P	G	G	P			R ^b
EA, ethylene-acrylic	E	G	G	E			
ABR, acrylate-butadiene	E	G	E	E			
Acrylic, ester-acrylic halide	G	G	F	E			
EPDM, ethylene-propylene	E	GE	E	E	R	R	R ^b
SBS, styrene-butadiene-styrene	P	E	F	P			
SEBS, styrene-ethylene-butylene-styrene	G	E	G	E			
ST, polysulfide	E	G	E	E			
FA, polysulfide	E		E	E			
AU, urethane	P	G	G	E			
PA, polyamides	P	G	E	E	R		X
PE, polyester	G	G	G	E			R
TPE, thermoplastic elastomer	G	E	E	E			
SI, silicone rubber	E	G	E	E			
FSL, fluorosilicone rubber	E	G	E	E			-
HFP, hexafluoroprene	E	G	E	E			
FKM, fluoroelastomers	GE	GE	E	E	X	X	R ^a
ETFE, ethylene-tetrafluorethylene	E	G	E	E	R	R	R
ECTFE, ethylene-chlorotrifluorethylene	E	E	E	E	R	R	R
FPM, perfluoroelastomers	E	G	E	E	R	R	R

Note: E = excellent; G = good; F = fair; P = poor; R = resistant; X = not resistant.

^a Wet only

^b Dry only.

Source: From Reference 14.

TABLE 4.14
Operating Temperature Ranges of Common Elastomers

Elastomer	Temp. (°F)		Temp. (°C)	
	Min	Max	Min	Max
NR, natural rubber	-59	175	-50	80
IR, isoprene rubber	-59	175	-50	80
CR, neoprene rubber	-13	203	-25	95
SBR, Buna-S	-66	175	-56	80
NBR, nitrile rubber, Buna-N	-40	250	-40	105
IIR, butyl rubber	-30	300	-34	149
CIIR, chlorobutyl rubber	-30	300	-34	149
CSM, Hypalon	-20	250	-30	150
BR, polybutadiene rubber	-150	200	-101	93
EA, ethylene-acrylic rubber	-40	340	-40	170
ABR, acrylate-butadiene rubber	-40	340	-40	170
EPDM, ethylene-propylene diene monomer	-65	300	-54	149
SBS, styrene-butadiene-styrene		150		65
SEBS, styrene-ethylene-butylene-styrene	-102	220	-75	105
ST, polysulfide	-50	212	-45	100
FA, polysulfide	-30	250	-35	121
AU, polyurethane	-65	250	-54	121
Polyamides	-40	300	-40	149
PE, polyesters	-40	302	-40	150
TPE, thermoplastic elastomer	-40	277	-40	136
SI, silicone	-60	450	-51	232
FSI, fluorosilicone	-100	375	-73	150
PVDF, polyvinylidene fluoride hexafluoropropene	-40	450	-40	232
FKM, fluoroelastomers	-10	400	-18	204
ETFE, ethylene-tetrafluorethylene	-370	300	-223	150
ECTFE, ethylene chlorotrifluorethylene	-105	340	-76	171
FPM, perfluoroelastomer	-58	600	-50	316

Source: From Reference 15.

of the cement solution, allowing the embedded steel to corrode. This sometimes is referred to as the carbonation of cement.

Sulfates will also cause concrete to deteriorate. In addition to being able to produce sulfuric acid, which is highly corrosive to concrete, sulfates are also reactive with some aggregates used in concrete mixes. Sulfate ions react with tricalcium aluminate to form sulfoaluminate hydrate with a large crystallized water content.

TABLE 4.15

Relative Low-Temperature Flexibility of the Common Elastomers

Elastomer	Relative Flexibility
NR, natural rubber	G-E
IIR, butyl rubber	F
EPDM, ethylene-propylene rubber	E
EA, ethylene-acrylic	P-F
FKM, fluoroelastomer	F-G
FSL, fluorosilicone	E
CSM, Hypalon (chlorosulfonated polyethylene)	F-G
CR, neoprene (polychloroprene)	F-G
NBR, Buna N (nitrile rubber)	F-G
BR, polybutadiene	G-E
IR, polyisoprene	G
Polysulfide T	F-G
SBR, Buna S (butadiene-styrene)	G
SI, silicone rubber	E
AU, polyurethane	G
EU, polyether urethane	G

Note: E = excellent; G = good; F = fair; P = poor.

Source: From Reference 16.

4.8.3.1 Protecting Concrete

Several steps can be taken to prolong the life of concrete. The first is to protect the reinforcing steel from corrosion by applying a rust preventative to the surface prior to embedding in the concrete mix. This keeps the steel from rusting if contacted by water and causing spalling of the concrete. In the past few years there has been a tendency in some instances to use stainless steel reinforcing rods to eliminate this potential problem.

A second approach is to provide a coating for the concrete. Before selecting an appropriate coating, consideration must be given to the condition of the concrete and the environment to which the concrete will be exposed. Proper surface preparation is essential. Surface preparations can be different for freshly placed concrete and for old concrete.

When concrete is poured, it is usually held in place by means of steel or wood forms that are removed when the concrete is still in its tender state. To facilitate their removal, release agents are applied to the forms prior to pouring. Oils, greases, and proprietary product release agents are left on the surface of the poured concrete. They must be removed if they will interfere with the adhesion of subsequent coatings.

TABLE 4.16
Brittle Points of Common Elastomers

Elastomer	Brittle Point	
	(°F)	(°C)
NR, IR	-68	-56
CR	-40	-40
SBR	-76	-60
NBR	-32 to -40	-1 to -40
CSM	-40 to -80	-40 to -62
BR	-68	-56
EA	-75	-60
EPDM, EPT	-90	-68
SEBS	-58 to -148	-50 to -100
Polysulfide SF	-60	-51
Polysulfide FA	-30	-35
AU	-85 to -100	-65 to -73
Polyamide No. 11	-94	-70
PE	-94	-70
TPE	-67 to -70	-55 to -60
SI	-75	-60
FSI	-75	-60
HFP	-80	-62
FKM	-25 to -75	-32 to -59
ETFE	-150	-101
ECTFE	-105	-70
FPM	-9 to -58	-23 to -50

Source: From Reference 17.

Quite often, curing compounds are applied to fresh concrete as soon as practical after the forms have been removed. These are liquid membranes based on waxes, resins, chlorinated rubber, or other film formers, usually in a solvent. Pretesting is necessary to determine whether or not they will interfere with the coating to be applied.

Generally, they are added to concrete mixes in order to speed up or slow down the cure, add air to the mix, or obtain other special effects that will not interfere with surface treatments to improve durability. The concrete supplier can furnish specific data regarding the admixtures. If in doubt, try a test patch of the coating material to be used.

4.8.3.2 Coating Selection

The coating to be selected will depend on the atmospheric conditions to be encountered. Not only will the normal atmospheric pollutants have to be considered but any special local pollutants will also have to be taken into account. Also to be considered are the local weather conditions, which will result in minimum and maximum temperatures as the seasons change. There are many monolithic surfacings or coatings from which to choose. Any selection must be based on the resistance required, life expectancy, maintenance costs, and initial costs, including necessary surface preparation.

The most common monolithic surfacings are formulated from the following resins:

1. Epoxy, including epoxy novalac
2. Polyester
3. Vinyl ester, including vinyl ester novalac
4. Acrylic
5. Urethane

Monolithic surfacings are installed at thicknesses of 1/16 in. (1.5 mm) to 1/2 in. (13 mm). Refer to Table 4.17 for the atmospheric corrosion resistance of monolithic concrete surfacings.

TABLE 4.17

Atmospheric Corrosion Resistance of Monolithic Concrete Surfacings

Surfacing	Atmospheric Pollutant							
	NO _x	H ₂ S	SO ₂	CO ₂	UV	Chloride Salt	Weather	Ozone
Epoxy–bisphenol A Aromatic amine hardener	R	X	X	R	R	R	R	R
Epoxy novalac	R	X	X	R	R	R	R	R
Polyesters:								
Isophthalic	R	R	X	R	RS	R	R	R
Chlorendic	R	R	X	R	RS	R	R	R
Bisphenol A fumurate	R	R	X	R	RS	R	R	R
Vinyl esters	R	R	R	R	R	R	R	R
Acrylics	R		R	R	R	R	R	R
Urethanes	R		X		R	R		

Note: R = resistant; X = not resistant; and RS = resistant when stabilized.

Source: From Reference 18.

4.8.3.3 Polymer Concrete

Polymer concrete is a chemically resistant synthetic concrete consisting of low-viscosity binders and inert aggregates, which when combined and thoroughly mixed produces a synthetic material that can be precast or poured in place. It can also be used as a concrete surfacing. When applied in thicknesses greater than 1/2 in. (13 mm), it is considered a polymer concrete. When applied in lesser thickness, the material is referred to as a surfacing or coating.

Polymer concretes are not the same as polymer-modified Portland cement concrete. Polymer concretes are composed totally of synthetic resin compounds with fillers. They do not contain any Portland cement. Polymerized Portland cement concrete can use some of the same generic resins as used in polymer concrete, but with different results.

The primary resins used to formulate polymer concretes include:

1. Furan
2. Epoxy, including novalac
3. Polyester
4. Vinyl ester, including vinyl ester novalac
5. Acrylics
6. Sulfur

Before pouring polymer concrete mixes, a liquid-tight membrane should be placed over the substrate. Such a membrane will act as a liquid barrier and separate the polymer concrete from the surface below it, allowing it to move as a unit. The substrate must be smooth, and penetrations through the polymer concrete should be centered between joints.

Depending on the service, polymer concrete is cast in thicknesses from 1/2 in. (13 mm) to several inches, either with or without reinforcing. Castable polymer concretes are mixed and cast in a manner similar to that of Portland cement concrete, being poured into forms to harden. Troweled applications are generally thin coatings of less than 3/4 in. (20 mm) and are troweled in place with or without reinforcement.

Like all cementitious materials, polymer concretes are inflexible and tend to brittleness. Refer to Table 4.18 for the resistance of polymer concretes to atmospheric corrosion.

4.8.3.4 Mortars and Grouts

Chemically resistant mortars and grouts are based on organic and inorganic chemistry. They consist of a liquid resin or an inorganic binder; fillers such as silica, carbon, or combinations of the same; and a hardener or

TABLE 4.18

Resistance of Polymer Concretes to Atmospheric Corrosion

Polymer Concrete	Atmospheric Pollutant							
	NO _x	H ₂ S	SO ₂	CO ₂	UV	Chlorides	Weather	Ozone
Furan	X	R	R	R		R	R	
Epoxy-bisphenol A with aromatic amine hardener	R	X	X		R	R	R	R
Epoxy novalac	R	X	X		R	R	R	R
Polyester resins:								
Chlorendic type	R	R	X	R	RS	R	R	R
Bisphenol A fumarate type	R	R	X	R	RS	R	R	R
Acrylics	R		R	R	R	R	R	R
Sulfur	R	X	R	R	R	R		

Note: R = resistant; RS = resistant when stabilized; and X = not resistant.

Source: From Reference 19.

catalyst system that may be incorporated in the filler or added as a separate component.

A mortar is a material having a heavy consistency that can support the weight of a brick or tile without being squeezed from between the joints while curing.

A grout is a thin or "soupy" mortar used for filling joints between previously laid brick or tile. Chemically resistant machinery grouts contain larger aggregates than tile grout and have a different resin viscosity.

The effectiveness and workability of a mortar or grout depends on the proper selection of fillers, particle size, resin viscosity, reactivity of catalysts and hardeners. Hardener systems must be formulated for application in the temperature range of approximately 60 to 90°F (15 to 32°C). The lower the temperature, the slower the set; the higher the temperature, the faster the set.

Carbon, silica, or combinations of the two are the most popular fillers used. Carbon is the most inert of the fillers and therefore is the one most often selected. The most popular resin systems are some of the same used for monolithic surfacing. Refer to Table 4.19 for their atmospheric corrosion resistances.

4.8.4 Ceramics

As with metals, the corrosion of ceramics can take place by one or a combination of mechanisms. In general, a corrodent will attack a ceramic and form a corrosion product. Whether the reaction product is a gas or a solid will determine if the product remains on the surface or is a fugitive. Reaction products may be gas, liquid, solid, or any combination thereof. If the reaction

TABLE 4.19

Atmospheric Corrosion Resistance of Mortars and Grouts

Mortar/Grout	Atmospheric Pollutant							
	NO _x	H ₂ S	SO ₂	CO ₂	UV	Chloride Salt	Weather	Ozone
Epoxy with aromatic amine hardener	R	X	X	R	R	R	R	R
Furans	X	R	R	R		R	R	
Phenolics	X	R	R	R		R		
Polyesters	R	R	X	R	RS	R	R	R
Vinyl esters	R	R	R	R	R	R	R	R
Sulfur	R	X	R	R	R	R	R	
Sodium silicate:								
Normal	X	R	X		R	R		
Water-resistant	R	R	R		R	R	R	
Potassium silicate with setting agent:								
Organic	X	X	X	R	R	R		
Inorganic	R	R	R	R	R	R	R	
Silica	R	R	R	R	R	R	R	

Note: R = resistant; RS = resistant when stabilized; and X = not resistant.

Source: From Reference 20.

product formed is a solid, it can form a protective layer against further corrosion. When the reaction product is a combination of a solid and a liquid, the reaction layer can be removed.

The fundamental concepts of chemistry can assist in understanding the corrosion of ceramics. A ceramic having a basic character tends to be attacked by an environment with an acidic character, whereas a ceramic having an acidic character tends to be attacked by an environment basic in character. Also, ionic materials tend to be soluble in polar solvents, whereas covalent materials tend to be soluble in nonpolar solvents, and the vapor pressure of covalent materials is generally greater than that of ionic materials and therefore covalent materials tend to vaporize or sublime more quickly.

The resistance of ceramics to corrosion is due to one of three basic behaviors: immunity, passivation, or kinetically limited corrosion. When a ceramic is thermodynamically incapable of spontaneous reaction with its environment, it is referred to as having *immunity*. When the necessary thermodynamic data are available, this type of corrosion resistance can be predicted by calculation. Metals, except for the precious metals such as gold, do not exhibit immunity.

For corrosion to occur without input of energy from outside the reaction, it must be thermodynamically and kinetically possible. It is possible to calculate whether a specific corrosion reaction can occur spontaneously, providing sufficient thermodynamic data are available. If on the basis of the available thermodynamic data it is determined that a given corrosion reaction cannot take place, then it is reasonable to assume that the particular corrosion reaction is not a practical problem. If the thermodynamic data predict that a given corrosion reaction can occur, it still may not be a practical problem if the reaction is kinetically limited.

The primary problem in thermodynamically predicting corrosion lies in the ability to find adequate and complete thermodynamic data and considering all the possible corrosion reactions that could be important for complex ceramic compositions and structures, the use of thermodynamic data must be carefully applied and full consideration given to the impact of kinetic limitations.

4.8.4.1 Forms of Corrosion

Ceramics are subject to many of the same forms of corrosion as metals. However, there are some important differences in the corrosion mechanisms.

Uniform corrosion. For uniform corrosion to take place in a metal, a galvanic cell must be formed. This is not possible in a ceramic because ceramics are insulators and no conductor is present — a requirement for a galvanic cell.

Uniform corrosion in a ceramic takes place as a result of chemical dissolution. The corrosion product formed is nonprotective, being either poorly adherent, soluble, or a good transport medium for the corrodent to the ceramic face. This is a predictable form of corrosion based on test data or experience.

Crevice corrosion. The mechanism of crevice corrosion for ceramics is similar to that of metals. Crevice corrosion develops in an occluded area of a corroding material. Once corrosion has started within the crevice, corrosion rates within the occluded area will increase with time as a result of either (1) depletion of a passivating component within the crevice, or (2) increasing acidity within the crevice, or (3) a combination of both.

However, there is a difference in the mechanism for ceramics vs. metals. Increasing activity within the crevice area of a ceramic occurs only if the ceramic is electrically conductive.

Pitting. Pitting is a form of highly localized corrosion. Pits are the result of damage to a protective film. The damage might be the result of a corrosive attack of the protective film, or the result of mechanical abrasion of the film, or from inclusions or pockets of a susceptible phase. In the latter cases, attack takes place at the damaged site, which causes a hole to develop in the surface. Pitting can be detrimental to the function of the ceramic component since it may decrease the effective strength of the ceramic.

Cavitation. Cavitation, per se, is not a form of corrosion; however, it is closely related. Cavitation is mechanical in nature. It is the mechanical removal of material resulting from the implosion of vapor bubbles in the liquid. In so

doing, the protective film is removed, which permits corrosion to take place, primarily in the form of pitting. There is also the possibility that corrosion will promote cavitation damage by dissolving a matrix phase that holds hard particles. Once these hard particles are loosened cavitation can take place.

Erosion corrosion. Erosion corrosion is similar to erosion but the mechanics are somewhat different. In erosion corrosion the fluid or moving particle removes a corrosion product on the ceramic surface. When this occurs the ceramic forms additional corrosion product, which would otherwise be protective, followed by removal of this protective product by erosion. As the cycle repeats, localized ceramic loss occurs.

Ordinary erosion is the direct removal of a ceramic or component by mechanical means with no resulting corrosion.

Galvanic corrosion. The general principles of galvanic corrosion of metals apply to the galvanic corrosion of ceramics. Basic requirements for galvanic corrosion to proceed are as follows:

1. There must be two electrically conductive but galvanically different ceramics in electrical contact with each other.
2. There must be a corrosive electrolyte in contact with both materials.

As with metallic galvanic corrosion, the greater the galvanic difference between the two ceramics, the greater will be the galvanic effect.

Selective leaching. Ceramics consisting of multiphases are subject to selective leaching. When a phase is significantly less resistant to a specific corrodent, the susceptible phase will be dissolved from the matrix while the other phases remain unaffected.

Specific ions, rather than entire phases, may also be leached. What ions are dissolved is specific to the corrosive and the ceramic.

Weatherability, hardness, and other aspects of performance are affected by the leaching of small phases or specific ions.

Intergranular corrosion. Selective leaching and intergranular corrosion are related but intergranular corrosion is unique in that it takes place along the grain boundaries. Corrosion results from impurities and additives that tend to segregate along the grain boundaries under attack.

Corrosion-assisted cracking. Stress corrosion cracking (SCC) of ceramics is generally recognized as a type of subcritical crack growth. Relative humidity is an important factor in (SCC) crack growth for many ceramics. Water generally increases SCC crack growth rates.

SCC occurs as a result of the combined action of internal or external stresses and an aggressive environment.

Summary. As can be seen from the foregoing, ceramics are susceptible to the same general forms of corrosion as metals, although in some cases the mechanisms may be different. Atmospheric corrosion of ceramics can take

TABLE 4.20

Atmospheric Corrosion Resistance of Selected Glasses

Type of Glass	Atmospheric Pollutant								
	Weathering	Chloride	SO ₂	NO _x	H ₂ S	CO ₂	UV	Ozone	Water
Sodium silicate	2	1	1			2	1		2
Alumina silicate	1	3	3	3	3	3	1		1
Borosilicate	1	1	1	1	1	1	1	1	1
Lead glasses	2	2	2	2			1		2
Fluoride glasses	1	1	1				1		1
96% Silica	1	1	1				1		

Note: 1 = negligible effect; 2 = some attack; and 3 = not recommended.

Source: From Reference 21.

place through any or all of these forms, depending on the specific ceramic and the elements of the atmosphere.

The same factors that promote the atmospheric corrosion of metals — that is, time of wetness, atmospheric types, initial exposure conditions, sheltering, wind velocity, and the nature of corrosion products — also affect the atmospheric corrosion of ceramics.

The porosity of ceramic materials is another factor that affects their corrosion resistance. Voids present in the ceramics provide a greater surface area for attack and allow retention of the corrosion product, which results in mechanical failure due to the formation of voluminous corrosion products in pores.

4.8.4.2 Corrosion of Specific Ceramics

The primary problem facing ceramics in relation to atmospheric corrosion is that of attack by atmospheric water vapor. This attack is time dependent and degrades the mechanical properties of the ceramic. This form of attack is referred to as weathering and is essentially attack by water vapor, CO₂, and SO₂. Many ceramics are immune to this form of attack at ambient temperatures. Table 4.20 lists the atmospheric corrosion of selected glasses, and Table 4.21 does likewise for other selected ceramics.

4.8.5 Wood

Wood, when exposed outdoors, undergoes a number of physical and chemical phenomena. These are caused by moisture influences, sunlight, and temperature. Wood is also subject to attack by insects and fungi. All of these stress factors have an effect on the wood, as shown:

Stress Factor	Weathering Factor
Photo-irradiation	Photochemical degradation
Moisture changes	Dimensional changes, deformation, cracking, leaching, hydrolysis
Wind, rain, hail, dust, pollution	Erosion
Microorganisms	Discoloration

All the stress factors are influenced by the following:

1. Conditions of weather exposure
2. Time factors
3. Wood properties
4. Quality of design
5. Properties and application of finish
6. Maintenance

The natural weathering process of wood creates a simple finish. The wood surfaces gradually change in color and texture, and then remain unaltered for a long period of time providing that the wood does not decay. Normally, the light-colored woods will become darker and the dark-colored woods will become lighter. During the continuing weathering process, all woods become gray, accompanied by photodegradation and a gradual loss of wood cells at the surface. Because of this, exposed unfinished wood will slowly wear away by erosion.

TABLE 4.21

Atmospheric Corrosion Resistance of Selected Ceramics

Material	Resistance to:			
	CO ₂	CO	NH ₃	SO ₂
Zircon	A	A	A	A
Bonded 99% alumina	A	A	A	A
Fused cast alumina	A	A	A	A
Zirconia, stabilized	A	A	E	A
Silicon carbide	B	B	A	A
Magnesite	A	B-C	A	C-D

Note: A = no reaction; B = slight reaction, material suitable; C = reaction, material suitable under certain conditions; D = reaction, material not suitable unless tested under operating conditions; and E = rapid attack, material unsuitable.

Source: From Reference 22.

The weathering process is a slow-acting surface phenomenon. Most soft woods erode at an average rate of approximately 1/4 in. per century, whereas dense hardwoods erode at a rate of only 1/8 in. per century. In cold northern climates, erosion rates of as low as 1/32 in. per century have been reported. Western red cedar, which is a typical very-low-density softwood, may erode at a rate as high as 1/2 in. per century.

Several factors affect the physical loss of wood substance from the wood surface during weathering. These factors include not only wood species and density, but also

1. Growth rate
2. Ring orientation
3. Wind
4. Degree of exposure
5. Amount of irradiation
6. Rain action

Swelling and shrinkage stresses, caused by fluctuations in moisture content, accompany the loss of wood from the surface. Grain raising, surface roughening, differential swelling of earlywood and latewood bands, and the formation of small parallel cracks and checks are the result. In addition, warpage might occur, and larger and deeper cracks might develop.

The growth of dark-colored spores and micelia of fungi or mildew on the surface usually accompanies the weathering process. These impart a dark gray, uneven, and unsightly appearance to the wood. In such species as redwood and Western red cedar, highly colored wood extractives add to the color of the weathered wood. In areas where the wood is not exposed to the sun and where the extractives are not washed away by rainwater, the dark brown color of the extractives may persist for a long time.

Wood deteriorates due to two principal causes: chemical and biological attack. The chemical resistance of the wood depends on the ability of the wood cells to resist chemical action and the extent to which the chemical penetrates into the wood.

Wood is most resistant to chemical attack in the pH range of 2 to 9. It is resistant to weak acids but concentrated mineral acids tend to hydrolyze the cellulose and hemicellulose constituents. Oxidizing agents such as ozone attack the grain in the wood, which tends to bind the fibers together. The cellulose can also be oxidized by strong oxidizing agents such as nitric acid. Aqueous solutions of nitric acid, sulfuric acid, sodium hydroxide, and hydrochloric acid can cause the most damage because swelling and degradation are simultaneous.

Decay resistance of timbers varies greatly, depending on the type of tree and the type of wood. Hardwood is more resistant than softwood because

TABLE 4.22
Relative Resistance to Decay (Heartwood)

Trees Having:	
High Natural Decay Resistance	Moderate Decay Resistance
Northern white cedar	Douglas fir
Southern cypress	Eastern white pine
Western red cedar	Southern yellow pine
Redwood	Western larch
Chestnut	White oak
Black locust	Red gum
Black walnut	
Black cherry	

Source: From Reference 23.

of the lower permeability and presence of toxic substances. Table 4.22 shows the relative resistance to decay of the heartwood of various tree species. Table 4.23 provides a more comprehensive listing. Those not shown have little or no resistance without being treated.

Wood-destroying fungi are primitive forms of plant life. They make use of lignin (white rots) or the cellulose (brown rots) of the wood for food. The metabolic process can be halted by controlling moisture, air, or temperature. Optimum conditions for growth are 10 to 25% moisture content, 20% of wood volume as air, and a temperature range of 75 to 95°F (23 to 35°C). Freezing of the wood does not kill the fungus; it only causes dormancy. Fungus growth can be inhibited by impregnation of the wood.

Wood is also subject to attack by insects, the most serious of which in the United States are termites of the subterranean type. These insects remove the wood internally, leaving few signs of their activity. The cellulose in the wood is acted on by protozoa in the insect's intestine and converted to sugar for food. Control can be achieved by following construction techniques that prevent the termites from gaining entry into the structure. Because termites live underground, their entry can be prevented by the installation of metal strips between the wood and the foundation material. The U.S. Department of Agriculture has several publications available describing construction features to prevent termite entry. Termites can also be controlled by poisoning the soil or pressure-treating the lumber with toxic chemicals.

Another insect that can cause extensive damage is the wood-boring beetle. Small surface holes and piles of sawdust are indications of the presence of this insect. Thorough surface coatings of paint or varnish are the best control measures.

TABLE 4.23
Resistance of Wood to Decay

Softwoods		Hardwoods	
Bald cypress	E	Ash	P
Douglas fir	F-G	Aspen	VP
Hemlock, western	P	Balsa	P
Larch, western	F	Beech, American	P
Pine, ponderosa	F	Birch, yellow	G
Redwood, virgin	E	Cherry, black	E
Spruce, Sitka	F	Chestnut, American	E
White cedar	E	Cottonwood, eastern	VP
		Elm, American	F
		Elm, rock	F
		Hickory, shayback	G
		Magnolia, southern	P
		Mahogany	G
		Maple, sugar	P
		Maple, silver	P
		Oak, red	G
		Oak, white	G
		Sycamore	P
		Sweetgum	F
		Walnut, black	E
		Poplar, yellow	P

Note: E = excellent; G = good; F = fair; P = poor; and VP = very poor.

Source: From Reference 23.

4.8.5.1 Plywood

Wood layers or plies of veneer, or veneer and lumber in which alternate plies are laid with the grain at right angles, are given the name *plywood*. By alternating the grain direction of each ply, in adjacent plies, the two face directions are equalized in strength, stiffness, and dimensional changes. Plywood is produced as either interior or exterior type. Exterior-type plywood is designed to retain its shape and strength when repeatedly wetted and dried under adverse conditions and be suitable for permanent outdoor exposure. It is sometimes referred to as *marine plywood*. Exterior plywood is usually bonded with hot-pressed phenol resins.

4.8.5.2 Reconstituted Wood Products

Reconstituted wood products are produced by the formation of small pieces of wood into large sheets. The finished product can be classified as *fiberboard* or *particle board*, depending on the nature of the basic wood component.

Fiberboards are produced from mechanical pulps. Hardwood is a relatively heavy type of fiberboard that is designed for exterior exposure.

Some reconstituted wood products can be factory primed with paint and some may have a factory-applied topcoat to protect the wood from fungi and insects; treatment with toxic chemicals provides the necessary protection. A variety of materials can be used but oil and oil-borne preservatives predominate. The most widely used is coal tar creosote, which is a by-product distilled from the coal tar produced by the high-temperature carbonization of bituminous coal. It is a heterogeneous mixture of liquid and solid hydrocarbons. To increase penetration and reduce the coat, coal tar solutions and creosote-petroleum solutions are used extensively. Solutions as high as 50% have been used. A disadvantage to this type of treatment is the inability to apply paint.

When cleanliness and paintability are required, pentachlorophenol in volatile petrochemical carriers is used. Concentrations of not less than 5% are used. These solutions are in the same price range as coal tar emulsions and provide the same degree of protection.

Water-borne solutions of inorganic salts are also used. These have the advantages over the oils of greater ease of penetration and freedom from fire hazards and odor. The disadvantage is that they cause swelling and some react with metal. The primary preservative used is chromated zinc chloride. Other typical salts used include:

1. Acid cupric chromate
2. Ammonial copper arsenate
3. Chromated copper arsenate
4. Chromated zinc arsenate
5. Copperized chromated zinc chloride

Wood can be treated with preservatives in several ways, including:

1. Under pressure in closed vessels
2. Dipping
3. Hot and cold soak
4. Diffusion

Of the four methods listed, treatment under pressure in closed vessels is the predominant method employed for lumber used in engineering structures.

4.8.5.3 Applied Exterior Wood Finishes

There are a variety of finishes that can be applied to wood that is to be exposed to the weather and atmospheric conditions. The finish selected will depend on the appearance and degree of protection desired and on the species of wood to be protected. In addition, different finishes provide varying degrees of protection; therefore, the type, quality, quantity, and application method of the finish must be considered when selecting and planning the finishing of wood and wood products. Table 4.24 shows the relative painting and weathering properties of various woods. The classification of paintability results from the nature of the specific wood. The higher the rating, the greater the care that must be taken in applying the finishes.

Paints. Paint coatings on wood provide the most protection because they block the damaging ultraviolet light rays from the sun. They may be either oil based or latex based. Either type is available in a wide range of colors. Oil or alkyd paints are borne by an organic solvent, whereas latex-based paints are water-borne. The three primary reasons for using paints are to protect the wood surface from weathering, to conceal certain defects, and for aesthetic purposes.

Paints do not penetrate the wood surface too deeply. A surface film is formed while obscuring the wood grain. Paints perform best on smooth, edge-grained lumber of lightweight species. If the wood becomes wet, the paint film blisters or peels.

A nonporous paint film provides the most protection for wood against surface erosion and the largest selection of colors of any of the wood finishes. Paint accomplishes this by retarding the penetration of moisture, and reducing the problem of discoloration by wood extractives, paint peeling, and warping of the wood. However, paint is not a preservative. It does not prevent decay if conditions are favorable for fungi growth. Wood preservatives must be used for this purpose.

Water-repellent preservatives. Water-repellent preservatives contain a fungicide or mildewcide (the preservative), a small amount of wax for water repellence, a resin or drying oil, and a solvent such as mineral spirits or turpentine. A water-repellent preservative can be used as a natural finish. These preservatives do not usually contain coloring pigments. The type of wood determines the color of the resulting finish. The mildewcide prevents wood from darkening.

During the first few years of application, the water-repellent preservative has a short life. Additional applications are usually required each year. Once the wood has weathered to a uniform color, the treatments are more durable and refinishing is required only when the surface starts to become unevenly colored by fungi.

Special color effects can be achieved by adding inorganic pigments to the water-repellent preservatives. The addition of pigment to the finish helps stabilize the color and increase the durability of the finish. Colors that match the natural color of the wood and extractives are usually preferred.

TABLE 4.24
Painting and Weathering Characteristics of Various Woods

Woods	Ease of Keeping Painted	Resistance to Weathering
<i>Softwoods</i>		
Cedar	1	A
Cypress	1	A
Redwood	1	A
Pine, ponderosa	3	B
Fir	3	B
Hemlock	3	B
Spruce	3	B
Douglas fir	4	B
Larch	4	B
<i>Hardwoods</i>		
Aspen	3	B-A
Basswood	3	B
Cottonwood	3	D-B
Magnolia	3	B
Yellow poplar	3	B-A
Beech	4	D-B
Birch	4	D-B
Gum	4	D-B
Lauan (plywood)	4	B
Maple	4	B
Chestnut	5-3	C-B
Walnut	5-3	C-B
Elm	5-4	D-B
Hickory	5-4	D-B
Oak, white	5-4	D-B
Oak, red	5-4	D-B

Note: 1 = easiest to keep well painted; 5 = most difficult. A = most resistant to weathering; D = least resistant to weathering.

Source: From Reference 24.

Water-repellent preservatives can also be used on bare wood prior to priming and painting or in areas where old paint has peeled, exposing bare wood. This treatment prevents rain or dew from penetrating into the wood, particularly at joints and end-grain, thereby reducing the swelling and shrinking of wood. This reduces the stress placed on the paint film, thus extending its service life.

Water repellents. Water repellents are water-repellent preservatives with the fungicide, mildewcide, and preservatives omitted. They are not effective natural finishes by themselves but are used as a stabilizing treatment prior to priming and painting.

Solid color stains. Solid color stains provide an opaque finish and are available in a wide range of colors. They contain a much higher concentration of pigment than the semitransparent stains. Solid color stains totally obscure the natural color and grains of the wood. Oil-based and latex-based solid color stains form a film similar to a paint film and as such can peel loose from the substrate. Both of these stains are similar to thinned paint and can usually be applied over old paint or stains, providing the old finish is securely bonded.

Semitransparent penetrating stains. Semitransparent penetrating stains are moderately pigmented and do not hide the wood grain. They do not form a surface film, are porous to water vapor, and penetrate the surface. Because they do not form a surface film, they do not blister or peel. Penetrating stains are alkyd or oil based, and may contain a fungicide or mildewcide as well as a water repellent. Latex-based stains are also available but do not penetrate the wood surface as do the oil-based stains.

These stains are not effective when applied over a solid color stain or over old paint. They are not recommended for use on hardwood but provide an excellent finish on weathered wood.

Transparent coatings. Conventional spar or marine varnishes produce a film-forming finish and are not generally recommended for exterior use on wood. Shellac or lacquers should never be used outdoors because they are brittle and very sensitive to water. Exposure to sunlight causes varnish coatings to become brittle and to develop severe cracking and peeling, often in less than 2 years.

4.8.6 Indoor Atmospheric Corrosion

Atmospheric corrosion poses a problem indoors as well as outdoors. As can be expected, there are obvious differences between outdoor and indoor exposure conditions that lead to a difference between outdoor and indoor corrosion behaviors.

Under outdoor exposure conditions, the aqueous layer is influenced by seasonal and daily changes in humidity and by precipitation (dew, fog, or snow), whereas indoors the aqueous layer is apt to be governed by relatively constant humidity conditions. In this situation, for all practical purposes, there will be an absence of wet-dry cycles, and therefore the effect of indoor humidity will introduce a time-of-wetness factor.

In general, most gaseous pollutants found outdoors have considerably lower levels of concentration indoors, with the exception of NH_3 and HCHO . Pollutants such as HCHO and HCOOH are important indoor corrosion

stimulants. They originate from adhesives, tobacco smoke, combustion of biomass, and plastics.

Another factor contributing to a decreased indoor corrosion rate is the decreased levels of indoor atmospheric oxidants, many of which are photochemically produced.

As discussed previously, not only the concentration of pollutants but also the air velocity determines the dry deposition velocity of corrosion stimulants. Because the air velocity is decreased indoors, significantly lower dry deposition velocities will take place.

Based on the differences between the indoor and outdoor factors affecting atmospheric corrosion rates, it follows that the corrosion rate of many metals is lower indoors than outdoors. This has been verified by examining the corrosion rates of copper, nickel, cobalt, and iron in eight indoor locations. In all cases, they exhibited a lower corrosion rate indoors than outdoors.

These factors do not eliminate the possibility of indoor atmospheric corrosion of materials. Designs must take into account the possibility of indoor atmospheric corrosion.

In an uncontaminated atmosphere at constant temperature, and with the relative humidity below 100%, corrosion of metals would not be expected. However, this is never the case because there are always normal temperature fluctuations: as the temperature decreases, the relative humidity increases; and because of hygroscopic impurities in the atmosphere or in the metal itself, the relative humidity must be reduced to a much lower value than 100% in order to ensure that no water condenses on the surface. For all metals there is a critical relative humidity below which corrosion is negligible. These critical relative humidities fall between 50 and 70% for steel, copper, nickel, and zinc.

In design, areas where dust particles can accumulate should be eliminated, as well as any crevices or pockets. Even in indoor atmospheres, carbon steel should be protected from corrosion by means of rust preventatives, painting, galvanizing, or other protective coatings, depending on the conditions of exposure. The use of low-alloy steel also helps to reduce or eliminate corrosion. Atmospheric corrosion is reduced when steel is alloyed in small concentrations with copper, potassium, nickel, and chromium.

References

1. Schweitzer, P.A., 1999, *Atmospheric Degradation and Corrosion Control*, New York: Marcel Dekker, p. 20.
2. Schweitzer, P.A., 1999, *Atmospheric Degradation and Corrosion Control*, New York: Marcel Dekker, p. 17.

3. Schweitzer, P.A., 1999, *Atmospheric Degradation and Corrosion Control*, New York: Marcel Dekker, p. 22, 23.
4. Schweitzer, P.A., 1999, *Atmospheric Degradation and Corrosion Control*, New York: Marcel Dekker, p. 42.
5. Kucera, V. and Mattsen, E., 1989, Atmospheric Corrosion, in Mansfield, F., Ed., *Corrosion Mechanisms*, New York: Marcel Dekker, p. 258.
6. Kucera, V. and Mattsen, E., 1989, Atmospheric Corrosion, in Mansfield, F., Ed., *Corrosion Mechanisms*, New York: Marcel Dekker, p. 266.
7. Schweitzer, P.A., 1999, *Atmospheric Degradation and Corrosion Control*, New York: Marcel Dekker, p. 117.
8. Schweitzer, P.A., 1999, *Atmospheric Degradation and Corrosion Control*, New York: Marcel Dekker, p. 119.
9. Schweitzer, P.A., 1999, *Atmospheric Degradation and Corrosion Control*, New York: Marcel Dekker, p. 132.
10. Schweitzer, P.A., 1999, *Atmospheric Degradation and Corrosion Control*, New York: Marcel Dekker, p. 133.
11. Schweitzer, P.A., 1999, *Atmospheric Degradation and Corrosion Control*, New York: Marcel Dekker, p. 137.
12. Schweitzer, P.A., 1999, *Atmospheric Degradation and Corrosion Control*, New York: Marcel Dekker, p. 136.
13. Schweitzer, P.A., 1999, *Atmospheric Degradation and Corrosion Control*, New York: Marcel Dekker, p. 150.
14. Schweitzer, P.A., 1999, *Atmospheric Degradation and Corrosion Control*, New York: Marcel Dekker, p. 145.
15. Schweitzer, P.A., 1999, *Atmospheric Degradation and Corrosion Control*, New York: Marcel Dekker, p. 144.
16. Schweitzer, P.A., 1999, *Atmospheric Degradation and Corrosion Control*, New York: Marcel Dekker, p. 146.
17. Schweitzer, P.A., 1999, *Atmospheric Degradation and Corrosion Control*, New York: Marcel Dekker, p. 147.
18. Schweitzer, P.A., 1999, *Atmospheric Degradation and Corrosion Control*, New York: Marcel Dekker, p. 172.
19. Schweitzer, P.A., 1999, *Atmospheric Degradation and Corrosion Control*, New York: Marcel Dekker, p. 176.
20. Schweitzer, P.A., 1999, *Atmospheric Degradation and Corrosion Control*, New York: Marcel Dekker, p. 179.
21. Schweitzer, P.A., 1999, *Atmospheric Degradation and Corrosion Control*, New York: Marcel Dekker, p. 193.
22. Schweitzer, P.A., 1999, *Atmospheric Degradation and Corrosion Control*, New York: Marcel Dekker, p. 193.
23. Schweitzer, P.A., 1999, *Atmospheric Degradation and Corrosion Control*, New York: Marcel Dekker, p. 198.
24. Schweitzer, P.A., 1999, *Atmospheric Degradation and Corrosion Control*, New York: Marcel Dekker, p. 201.
25. Leygraf, Atmospheric Corrosion in P. Marcus, J. Oudar, Eds., *Corrosion Mechanisms in Theory and Practice*, New York: Marcel Dekker, p. 423.

5

Corrosion of Polymer (Plastic) Materials

As discussed previously, metallic materials undergo a specific corrosion rate as a result of an electrochemical reaction. Because of this, it is possible to predict the life of a metal when in contact with a corrodent under a given set of conditions. This is not the case with polymeric materials. Plastic materials do not experience a specific corrosion rate. They are usually completely resistant to chemical attack or they deteriorate rapidly. They are attacked either by chemical reaction or by solvation. Solvation is the penetration of the plastic by a corrodent, which causes softening, swelling, and ultimate failure. Corrosion of plastics can be classified in the following ways as to the attack mechanism:

1. Disintegration or degradation of a physical nature due to absorption, permeation, solvent action, or other factors
2. Oxidation, where chemical bonds are attacked
3. Hydrolysis, where ester linkages are attacked
4. Radiation
5. Thermal degradation involving depolymerization and possibly repolymerization
6. Dehydration (rather uncommon)
7. Any combination of the above

Results of such attacks will appear in the form of softening, charring, crazing, delamination, discoloration, dissolving, or swelling.

The corrosion of polymer matrix composites is also affected by two other factors: the nature of the laminate and, in the case of the thermoset resins, the cure. Improper or insufficient cure time will adversely affect the corrosion resistance, whereas proper cure time and procedures will generally improve the corrosion resistance.

All polymers are compounded. The final product is produced to certain specific properties for a specific application. When the corrosion resistance of a polymer is discussed, the data referred to are that of the pure polymer. In many instances, other ingredients are blended with the polymer to enhance certain properties, which in many cases reduce the ability of the polymer to resist attack of some media. Therefore it is essential to know the makeup of any polymer prior to its use.

5.1 Radiation

Polymeric materials in outdoor applications are exposed to weather extremes that can be extremely deleterious to the material, the most harmful of which is exposure to ultraviolet (UV) radiation, which can cause embrittlement, fading, surface cracking, and chalking. Most plastics, after being exposed to direct sunlight for a period of years, exhibit reduced impact resistance, lower overall mechanical performance, and a change in appearance.

The electromagnetic energy from sunlight is normally divided into UV light, visible light, and infrared energy. Infrared energy consists of wavelengths longer than the visible red wavelengths, and starts above 760 nm. Visible light is defined as radiation between 400 and 760 nm. UV light consists of radiation below 400 nm. The UV portion of the spectrum is further subdivided into UV-A, UV-B, and UV-C. The effects of the various wavelength regions are shown below:

Ultraviolet Wavelength Regions

Region	Wavelength (nm)	Characteristics
UV-A	400–315	Causes polymer damage
UV-B	315–280	Includes the shortest wavelengths at the Earth's surface Causes severe polymer damage Absorbed by window glass
UV-C	280–100	Filtered by the Earth's atmosphere Found only in outer space

Because UV is easily filtered by air masses, cloud cover, pollution, and other factors, the amount and spectrum of natural UV exposure is extremely variable. Because the sun is lower in the sky during the winter months, it is filtered through a greater air mass. This creates two important differences between summer and winter sunlight: changes in the intensity of the light and in the spectrum. During the winter months, much of the damaging shortwavelength UV light is filtered out. For example, the intensity of UV at 320 nm changes about 8 to 1 from summer to winter. In addition, the shortwavelength solar cut-off shifts from about 295 nm in summer to about 310 nm in winter. As a result, materials sensitive to UV below 320 nm would degrade only slightly, if at all, during the winter months.

Photochemical degradation is caused by photons of light breaking chemical bonds. For each type of chemical bond there is a critical threshold wavelength of light with enough energy to cause a reaction. Light of any wavelength

shorter than the threshold can break the bond, but longer wavelengths of light cannot break it, regardless of their intensity (brightness). Therefore, the short-wavelength cutoff of a light source is of critical importance. If a particular polymer is sensitive only to UV light below 295 nm (the solar cutoff point), it will never experience photochemical degradation outdoors.

The ability to withstand weathering depends on the polymer type and which grades of a particular resin. Many resin grades are available with UV-absorbing additives to improve weatherability. However, the higher-molecular-weight grades of a resin generally exhibit better weatherability than lower-molecular-weight grades with comparable additives. In addition, some colors tend to weather better than others. The resistance to UV degradation of selected polymers is shown below:

Polymer	UV Degradation	Polymer	UV Degradation	Polymer	UV Degradation
ABS	RS	PEEK	RS	UHMWPE	RS
CPVC	R	PEI	R	Epoxy	R
ECTFE	R	PES	RS	Polyesters:	
ETFE	R	PFA	R	Bis A–fum	RS
FEP	R	PI	R	Halogenated	RS
HDPE	RS	PP	RS	Bis A–Bis A	RS
PA	R	PPS	R	Isophthalic	RS
PC	RS	PSF	R	Teraphthalic	RS
PCTFE	R	PTFE	R	Vinyl ester	R
PVDC	R	PVC	R	Furan	R
				Silicone	R

Note: R = resistant, RS = resistant if stabilized with UV protector.

5.2 Permeation

All materials are somewhat permeable to chemical molecules, but plastic materials tend to be an order of magnitude greater in their permeability than metals. Gases, liquids, or vapors will permeate polymers.

Permeation is a molecular migration through microvoids either in the polymer (if the polymer is more or less porous) or between polymer molecules. In neither case is there any attack on the polymer. This action is strictly a physical phenomenon. However, permeation can be detrimental when a polymer is used to line piping or equipment. In lined equipment, permeation can result in:

1. Failure of the substrate due to corrosive attack
2. Bond failure and blistering resulting from the accumulation of fluids at the bond when the substrate is less permeable than the liner, or from corrosion/reaction products if the substrate is attacked by the permeant
3. Loss of contents through substrate and liner as a result of the eventual failure of the substrate (in unbonded linings it is important that the space between the liner and the support member be vented to the atmosphere, not only to allow minute quantities of permeant vapors to escape, but also to prevent expansion of entrapped air from collapsing the liner)

Permeation is a function of two variables, one relating to diffusion between molecular chains and the other to the solubility of the permeant in the polymer. The driving force of diffusion is the partial pressure of gases and the concentration gradient of liquids. Solubility is a function of the affinity of the permeant for the polymer.

All polymers do not have the same rate of permeation; in fact, some polymers are not affected by permeation. The fluoropolymers are particularly affected. Table 5.1 depicts vapor permeation into PTFE, and Table 5.2 shows the vapor permeation into FEP. Table 5.3 provides permeation data for various gases into PFA and Table 5.4 gives the relative gas permeation into fluoropolymers.

TABLE 5.1
Vapor Permeation into PTFE^a

Gases	Permeation (g/100 in. ² /24 h/mil)	
	73°F/23°C	86°F/30°C
Carbon dioxide		0.66
Helium		0.22
Hydrogen chloride, anh.		<0.01
Nitrogen		0.11
Acetophenone	0.56	
Benzene	0.36	0.80
Carbon tetrachloride	0.06	
Ethyl alcohol	0.13	
Hydrochloric acid, 20%	<0.01	
Piperidine	0.07	
Sodium hydroxide, 50%	5×10^{-5}	
Sulfuric acid, 98%	1.8×10^{-5}	

^a Based on PTFE having a specific gravity of 2.2.

TABLE 5.2
Vapor Permeation into FEP

	Permeation (g/100 in. ² /24 h/mil) at		
	73°F/23°C	93°F/35 °C	122°F/50°C
<i>Gases:</i>			
Nitrogen	0.18		
Oxygen	0.39		
<i>Vapors:</i>			
Acetic acid		0.42	
Acetone	0.13	0.95	3.29
Acetophenone	0.47		
Benzene	0.15	0.64	
n-Butyl ether	0.08		
Carbon tetrachloride	0.11	0.31	
Decane	0.72		1.03
Ethyl acetate	0.06	0.77	2.9
Ethyl alcohol	0.11	0.69	
Hexane		0.57	
Hydrochloric acid, 20%	<0.01		
Methanol			5.61
Sodium hydroxide	4×10^{-5}		
Sulfuric acid, 98%	8×10^{-6}		
Toluene	0.37		2.93

TABLE 5.3
Permeation of Gases into PFA

Gas	Permeation at 77°F/25°C
	(cc/mil thickness /100 in. ² /24 h/atm)
Carbon dioxide	2260
Nitrogen	291
Oxygen	881

TABLE 5.4
Relative Gas Permeation into Fluoropolymers^a

Gas	PVDF	PTFE	FEP	PFA
Air	27	2,000	600	1,150
Oxygen	20	1,500	2,900	—
Nitrogen	30	500	1,200	—
Helium	600	35,000	18,000	17,000
Carbon dioxide	100	15,000	4,700	7,000

^a Permeation through a 100- μ m film at 73°F/23°C. Units = cm³/m² deg bar.

There is no relationship between permeation and the passage of materials through cracks and voids, although in both cases migrating chemicals travel through the polymer from one side to the other.

Some control can be exercised over permeation, which is affected by:

1. Temperature and pressure
2. The permeant concentration
3. The thickness of the polymer

Increasing the temperature will increase the permeation rate because the solubility of the permeant in the polymer will increase and, as the temperature rises, polymer chain movement is stimulated, permitting more permeant to diffuse among the chains more easily. The permeation rate of many gases increases linearly with the partial pressure gradient, and the same effect is experienced with the concentration gradient of liquids. If the permeant is highly soluble in the polymer, the permeability increases may not be linear. The thickness will generally decrease permeation by the square of the thickness.

The density of the polymer as well as the thickness will have an effect on the permeation rate. The greater the density of the polymer, the fewer voids through which permeation can take place. A comparison of the density of sheets produced from different polymers does not provide any indication of the relative permeation rates. However, a comparison of the density of sheets produced from the same polymer will provide an indication of the relative permeation rates. The denser the sheet, the lower the permeation rate.

The thickness of a lining affects the permeation rate. For general corrosion resistance, thicknesses of 0.010 to 0.020 inches are usually satisfactory, depending on the combination of the lining material and the specific corrodent. When mechanical factors such as thinning to cold flow, mechanical abuse, and permeation rates are a consideration, thicker linings may be required.

Increasing the lining thickness will normally decrease permeation by the square of the thickness. Although this would appear to be the approach to

follow to control permeation, there are disadvantages. First, as thickness increases, the thermal stresses on the boundary increase, which can result in bond failure. Temperature changes and large differences in coefficients of thermal expansion are the most common causes of bond failure. Thickness and modulus of elasticity are two of the factors that influence these stresses. Second, as the thickness of a lining increases, installation becomes difficult with a resulting increase in labor costs.

The rate of permeation is also affected by the temperature and temperature gradient in the lining. Lowering these will reduce the rate of permeation. Lined vessels, such as storage tanks, that are used under ambient conditions provide the best service.

Other factors affecting permeation consist of these chemical and physiochemical properties:

1. Ease of condensation of the permeant: chemicals that condense readily will permeate at higher rates.
2. The higher the intermolecular chain forces (e.g., van der Waals hydrogen bonding) of the polymer, the lower the permeation rate.
3. The higher the level of crystallinity in the polymer, the lower the permeation rate.
4. The greater the degree of crosslinking within the polymer, the lower the permeation rate.
5. Chemical similarity between the polymer and the permeant: when the polymer and the permeant have similar functional groups, the permeation rate will increase.
6. The smaller the molecule of the permeant, the greater the permeation rate.

5.3 Absorption

Polymers have the potential to absorb varying amounts of corrodents with which they come into contact, particularly organic liquids. This can result in swelling, cracking, and penetration to the substrate of a lined component. Swelling can cause softening of the polymer, introduce high stresses, and cause failure of the bond on lined components. If the polymer has a high absorption rate, permeation will probably take place. An approximation of the expected permeation and/or absorption of a polymer can be based on the absorption of water. These data are usually available. Table 5.5 provides the water absorption rates for the more common polymers, Table 5.6 gives the absorption rates of various liquids by FEP, and Table 5.7 provides the absorption rates of representative liquids by PFA.

TABLE 5.5
Water Absorption Rates of Polymers

Polymer	Water Absorption 24 h at 73°F/23°C (%)
PVC	0.05
CPVC	0.03
PP (Homo)	0.02
PP (Co)	0.05
EHMWPE	<0.01
ECTFE	<0.01
PVDF	<0.04
PVDC (Saran)	nil
PFA	<0.03
ETFE	0.029
PTFE	<0.01
FEP	<0.01

TABLE 5.6
Absorption of Selected Liquids by FEP^a

Chemical	Temp. (°F/°C)	Range of Weight Gains (%)
Aniline	365/185	0.3–0.4
Acetophenone	394/201	0.6–0.8
Benzaldehyde	354/179	0.4–0.5
Benzyl alcohol	400/204	0.3–0.4
n-Butylamine	172/78	0.3–0.4
Carbon tetrachloride	172/78	2.3–2.4
Dimethyl sulfide	372/190	0.1–0.2
Nitrobenzene	410/210	0.7–0.9
Perchloroethylene	250/121	2.0–2.3
Sulfuryl chloride	154/68	1.7–2.7
Toluene	230/110	0.7–0.8
Tributyl phosphate	392/200 ^b	1.8–2.0

^a Exposure for 168 h at their boiling points.

^b Not boiling.

TABLE 5.7
Absorption of Liquids by PFA

Liquid ^a	Temp. (°F/°C)	Range of Weight Gains (%)
Aniline	365/185	0.3–0.4
Acetophenone	394/201	0.6–0.8
Benzaldehyde	354/179	0.4–0.5
Benzyl alcohol	400/204	0.3–0.4
n-Butylamine	172/78	0.3–0.4
Carbon tetrachloride	172/78	2.3–2.4
Dimethyl sulfoxide	372/190	0.1–0.2
Freon 113	117/47	1.2
Isooctane	210/99	0.7–0.8
Nitrobenzene	410/210	0.7–0.9
Perchloroethylene	250/121	2.0–2.3
Sulfuryl chloride	154/68	1.7–2.7
Toluene	230/110	0.7–0.8
Tributyl phosphate ^b	392/200	1.8–2.0
Bromine, anh.	–5/–22	0.5
Chlorine, anh.	248/120	0.5–0.6
Chlorosulfonic acid	302/150	0.7–0.8
Chromic acid, 50%	248/120	0.00–0.01
Ferric chloride	210/100	0.00–0.01
Hydrochloric acid, 37%	248/120	0.00–0.03
Phosphoric acid, conc.	212/100	0.00–0.01
Zinc chloride	212/100	0.00–0.03

^a Samples were exposed for 168 h at the boiling point of the solvent. Exposure of the acidic reagents was for 168 h.

^b Not boiling.

The failure due to absorption can best be understood by considering the “steam cycle” test described in ASTM standards for lined pipe. A section of lined pipe is subjected to thermal and pressure fluctuations. This is repeated for 100 cycles. The steam creates a temperature and pressure gradient through the liner, causing an absorption of a small quantity of steam, which condenses to water within the inner wall. Upon pressure release or on introduction of steam, the entrapped water can expand to vapor, causing an original micropore. The repeated pressure and thermal cycling enlarges the pores, ultimately producing visible water-filled blisters within the liner.

In an actual process, the polymer may absorb process fluids, and repeated temperature or pressure cycling can cause blisters. Eventually, a corrodent may find its way to the substrate.

Related effects can occur when process chemicals are absorbed that may later react, decompose, or solidify within the structure of the polymer. Prolonged retention of the chemicals may lead to their decomposition within the polymer. Although it is unusual, it is possible for absorbed monomers to polymerize.

Several steps can be taken to reduce absorption. Thermal insulation of the substrate will reduce the temperature gradient across the vessel, thereby preventing condensation and subsequent expansion of the absorbed fluids. This also reduces the rate and magnitude of temperature changes, keeping blisters to a minimum. The use of operating procedures or devices that limit the ratio of process pressure reductions or temperature increases will provide added protection.

5.4 Thermoplasts (Thermoplastic Polymers)

A general rule as to the differences in the corrosion resistance of the thermoplasts can be derived from the periodic table. In the periodic table, the basic elements of nature are organized by atomic structure as well as by chemical nature. The elements are placed into classes with similar properties, that is, elements and compounds that exhibit similar behavior. These classes are the alkali metals, alkaline earth metals, transition metals, rare earth series, other metals, nonmetals, and noble (inert) gases.

The category known as halogens is of particular importance and interest in the case of thermoplasts. These elements include fluorine, chlorine, bromine, and iodine. They are the most electronegative elements in the periodic table, making them the most likely to attract an electron from another element and become a stable structure. Of all the halogens, fluorine is the most electronegative, permitting it to bond strongly with carbon and hydrogen atoms but not well with itself. The carbon–fluorine bond is predominant in PVDF and is responsible for the important properties of these materials. These are among the strongest known organic compounds. The fluorine acts like a protective shield for other bonds of lesser strength within the main chain of the polymer. The carbon–hydrogen bond, of which plastics such as PE and PP are composed, is considerably weaker. The carbon–chlorine bond, a key bond in PVC, is even weaker.

The arrangement of the elements in the molecule, the symmetry of the structure, and the degree of branching of the polymer chain are as important as the specific elements combined in the molecule. Plastics containing the carbon–hydrogen bonds such as PP and PE, and carbon–chlorine bonds such as PVC, ECTFE, and CTFE, are different in the important property of chemical resistance from fully fluorinated plastics such as PTFE.

The fluoroplastic materials are divided into two groups: (1) fully fluorinated fluorocarbon polymers such as PTFE, FEP, and PFA, called perfluoropolymers;

and (2) partially fluorinated polymers such as ETFE, PVDF, and ECTFE, called fluoropolymers. The polymeric characteristics within each group are similar but there are important differences between the groups.

5.5 Thermoset Polymers

Once formed, thermoset polymers, unlike the thermoplasts, cannot be heated to change their shape. Consequently, they cannot be recycled. These resins are initially liquid at room temperature and then by adding a catalyst or accelerator, they are changed into a rigid product that sets or cures into its final shape. The thermoset resins are high-molecular-weight polymers that are reinforced with glass or other suitable material to provide mechanical strength. The most commonly used resins are the vinyl esters, epoxies, polyesters, and furans.

For reinforcing these polymers, fibrous glass in the F and C grades is the most commonly used. Other reinforcing materials used include boron nitride, carbon fiber, ceramic fibers, graphite jute, Kevlar, metallic wire or sheet, monoacrylic fiber, polyester fiber, polypropylene fiber, quartz, sapphire whiskers, and S-grade glass.

The advantages of the thermosets are many; they

1. Are less expensive than the stainless steels
2. Have a wide range of corrosion resistance
3. Are light in weight
4. Do not require painting
5. May be formulated to be fire retardant

Unreinforced, unfilled thermoset polymers can corrode by several mechanisms. The type of corrosion can be divided into two main categories: physical and chemical.

Physical corrosion is the interaction of a thermoset polymer with its environment so that its properties are altered but no chemical reactions take place. The diffusion of a liquid into the polymer is an example. In many cases, physical corrosion is reversible; once the liquid is removed, the original properties are restored.

When a polymer absorbs a liquid or a gas resulting in plasticization or swelling of the thermoset network, physical corrosion has taken place. For a crosslinked thermoset, swelling caused by solvent absorption will be at a maximum when the solvent and polymer solubility parameters are exactly matched.

Chemical corrosion takes place when the bonds in the thermoset are broken by means of a chemical reaction with the polymer's environment. There

may be more than one form of chemical corrosion taking place at the same time. Chemical corrosion is usually not reversible.

As a result of chemical corrosion, the polymer itself may be affected in one or more ways. For example, the polymer may be embrittled, softened, charred, crazed, delaminated, discolored, dissolved, blistered, or swollen. All thermosets will be attacked in essentially the same manner. However, certain chemically resistant types suffer negligible attack or exhibit significantly lower rates of attack under a wide range of severely corrosive conditions. This is the result of the unequal molecular structure of the resins, including built-in protection of ester groups.

Curing the resin plays an important part in the chemical resistance of the thermoset. Improper curing will result in a loss of corrosion-resistant properties. Construction of the laminate and the type of reinforcing used also affect the corrosion resistance of the laminate. The degree and nature of the bond between the resin and the reinforcement also play an important role.

The various modes of attack affect the strength of the laminate in different ways, depending on the environment, other service conditions, and the mechanism or combination of mechanisms at work.

Some environments may weaken primary and/or secondary polymer linkages with resulting depolymerization. Other environments may cause swelling or microcracking, while still others may hydrolyze ester groupings or linkages. In certain environments, repolymerization can occur, with a resultant change in structure. Other results may be chain scission and decrease in molecular weight or simple solvent action. Attack or absorption at the interface between the reinforcing material and the resin will result in weakening.

In general, chemical attack on thermoset polymers is a go/no-go situation. With an improper environment, attack on the reinforced polyester will occur in a relatively short time. Experience has indicated that if an installation has operated successfully for 12 months, in all probability it will continue to operate satisfactorily for a substantial period of time.

Thermoset polymers are not capable of handling concentrated sulfuric acid (93%) and concentrated nitric acid. Pyrolysis or charring of the resin quickly occurs, so that within a few hours the laminate is destroyed. Polyesters and vinyls can handle 70% sulfuric acid for long periods of time.

The attack of aqueous solutions on reinforced thermosets occurs through hydrolysis, with water degrading bonds in the backbone of the resin molecules. The ester linkage is the most susceptible.

The attack by solvents is of a different nature. The solvent penetrates the resin matrix of the polymer through spaces between the polymer chains. Penetration between the polymer chains causes the laminate surface to swell, soften, and crack.

Organic compounds with carbon-carbon unsaturated double bonds, such as carbon disulfide, are powerful swelling solvents and show greater swelling action than their saturated counterparts. Smaller solvent molecules can penetrate a polymer matrix more effectively. The degree of similarity

between solvent and resin is important. Slightly polar resins, such as polyesters and vinyl esters, are attacked by mildly polar solvents.

Generally, saturated long-chain organic molecules, such as the straight-chain hydrocarbons, are handled well by the polyesters.

Orthophthalic, isophthalic, bisphenol, and chlorinated or brominated polyesters exhibit poor resistance to such solvents as acetone, carbon disulfide, toluene, trichloroethylene, trichloroethane, and methyl ethyl ketone. The vinyl esters show improved solvent resistance. Heat-cured epoxies exhibit better solvent resistance. However, the furan resins offer the best all-around solvent resistance.

Stress corrosion is another factor to consider. The failure rate of glass-reinforced composites can be significant. This is particularly true of composites exposed to the combination of acid and stress.

Under stress, an initial fiber fracture occurs, which is a tensile type of failure. If the resin matrix surrounding the failed fiber fractures, the acid is allowed to attack the next available fiber, which subsequently fractures. The process continues until total failure occurs.

5.6 Environmental Cracking

Stress cracks develop when a tough polymer is stressed for an extended period of time under loads that are small relative to the polymer's yield point. Cracking will occur with little elongation of the material. The higher the molecular weight of the polymer, the less likelihood of environmental stress cracking, other things being equal. Molecular weight is a function of the length of individual chains that make up the polymer. Longer chain polymers tend to crystallize less than polymers of lower molecular weight or shorter chains, and they also have a greater load-bearing capacity.

Crystallinity is an important factor affecting stress corrosion cracking. The less crystallization that takes place, the less likelihood of stress cracking. Unfortunately, the lower the crystallinity, the greater the likelihood of permeation.

Resistance to stress cracking can be reduced by the absorption of substances that chemically resemble the polymer and will plasticize it. In addition, the mechanical strength will also be reduced. Halogenated chemicals, particularly those consisting of small molecules containing fluorine or chlorine, are especially likely to be similar to the fluoropolymers and should be tested for their effect.

The presence of contaminants in the fluid may act as an accelerator. For example, polypropylene can safely handle sulfuric or hydrochloric acids, but iron or copper contamination in concentrated sulfuric or hydrochloric acid can result in the stress cracking of polypropylene.

6

Corrosion of Linings

On many occasions, lining, coating, and paint terminologies are used interchangeably. Technically, linings and paints are both coatings. Usually, a coating is referred to as a lining when subjected to immersion, such as the interior of a vessel, and paints refer to protective materials used to guard against atmospheric corrosion. This chapter deals with coatings that are used to protect the interior of a vessel and will be subject to immersion.

Of the various coating applications, the most critical is that of a tank lining application. The material must be resistant to the corrodent and be free of pinholes through which corrosives might penetrate and reach the substrate. The severe attack that many corrosives have on the bare tank emphasizes the importance of using the correct material and the correct procedure in lining a tank to obtain a perfect coating. It is also essential that the tank be designed and constructed in the proper manner to permit the application of a perfect lining.

In a tank lining there are usually four areas of contact with the stored product that may lead to different types of corrosion. These areas are the vapor phase (the area above the liquid level), the interphase (the area where the vapor phase meets the liquid phase), the area always immersed, and the bottom of the tank (where moisture and other contaminants of greater density may settle). Each of these areas can, at one time or another, be more severely attacked than the rest, depending on the type of material contained, the impurities present, and the amounts of oxygen and water present. In view of this, it is necessary to understand the corrosion resistance of the coating material under consideration, and not just the immersed condition.

Other factors that have an effect on the performance of the coating material are vessel design, vessel preparation prior to coating, application techniques of the coating material, curing of the coating, inspection, operating instructions, and temperature limitations. In general, the criteria for tank linings are:

1. Design of the vessel
2. Lining selection
3. Shell construction
4. Shell preparation
5. Lining application
6. Cure of the lining material

7. Inspection of the lining
8. Safety
9. Causes of failure
10. Operating instructions

6.1 Liquid Applied Linings

Liquid applied linings are coatings that can be applied by spraying or by troweling. As mentioned previously, if a tank lining is going to provide the corrosion protection desired, it is essential that the:

1. Vessel is properly designed
2. Correct coating is specified for the application
3. Vessel shell is properly prepared
4. Coating is properly applied and inspected

6.1.1 Design of the Vessel

All vessels to be lined should be of welded construction. Riveted tanks will expand or contract, thus damaging the lining and causing leakage. Butt-welding is preferred but lap welding may be used, providing a fillet weld is used and all sharp edges are ground smooth (see Figure 6.1). Butt welds need not be ground flush but they must be ground to a smooth, rounded contour. A good way to judge a weld is to run your finger over it. Sharp edges can be detected easily. All weld spatter must be removed (see Figure 6.2).

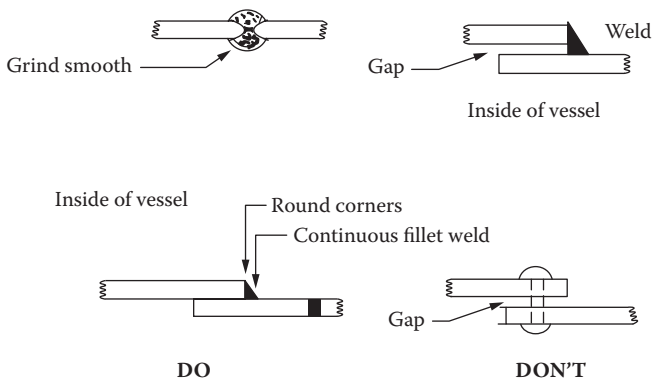

FIGURE 6.1

Butt welding preferred rather than lap welding or riveted construction.

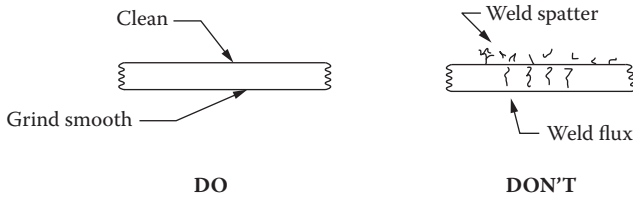

FIGURE 6.2
Remove all weld spatter and grind smooth.

Any sharp prominence may result in a spot where the film thickness will be inadequate and noncontinuous, thus causing premature failure.

If possible, avoid the use of bolted joints. Should it be necessary to use a bolted joint, it should be made of corrosion-resistant materials and sealed shut. The mating surface of steel surfaces should be gasketed. The lining material should be applied prior to bolting.

Do not use construction that will result in the creation of pockets or crevices that will not drain or that cannot be properly sandblasted and lined (Figure 6.3).

All joints must be continuous and solid welded. All welds must be smooth with no porosity, holes, high spots, lumps, or pockets (Figure 6.4).

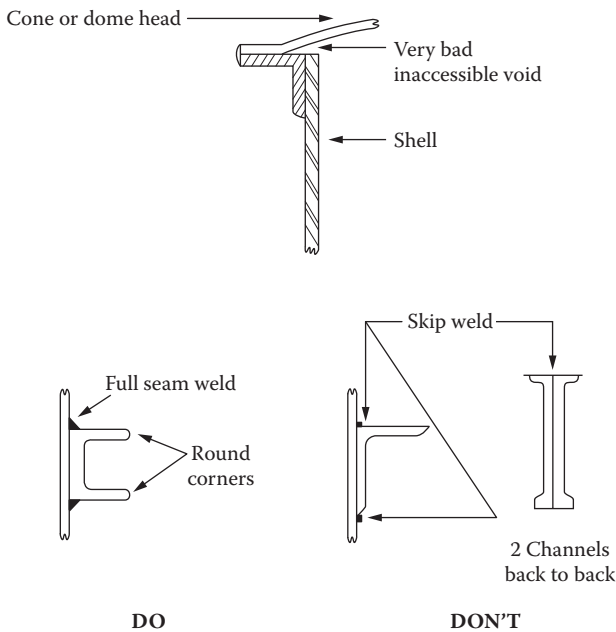
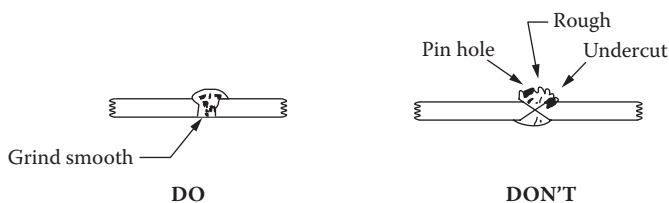

FIGURE 6.3
Avoid all pockets or crevices that cannot be properly sandblasted and lined.

**FIGURE 6.4**

All joints must be continuous solid welded and ground smooth.

All sharp edges must be ground to a minimum of 1/8-in. radius (Figure 6.5).

Outlets must be of flanged or pad type rather than threaded. If pressure requirements permit, use slip-on flanges, as the inside diameter of the attaching weld is readily available for radiusing and grinding. If pressure dictates the use of weld neck flanges, the inside diameter of the attaching weld is in the throat of the nozzle. It is therefore more difficult to repair surface irregularities such as weld undercutting by grinding (see Figure 6.6).

Stiffening members should be placed on the outside of the vessel rather than on the inside (Figure 6.7).

Tanks larger than 25 ft in diameter may require three manways for working entrances. Usually, two are located at the bottom (180° apart) and one at the top. The minimum opening is 20 in., but 30 in. is preferred.

On occasion, an alloy is used to replace the steel bottom of a vessel. Under these conditions, galvanic corrosion will take place. If a lining is applied to the steel and for several inches (usually 6 to 8 in.) onto the alloy, any discontinuity in the lining will become anodic. Once corrosion starts, it progresses rapidly because of the bare exposed alloy cathodic area. Without the lining, galvanic corrosion would cause the steel to corrode at the weld area, but at a much lower rate. The recommended practice therefore is to line the alloy

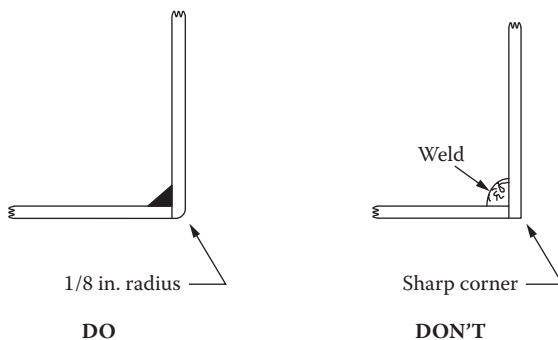
**FIGURE 6.5**

Grind all sharp edges to a minimum 1/8-in. radius.

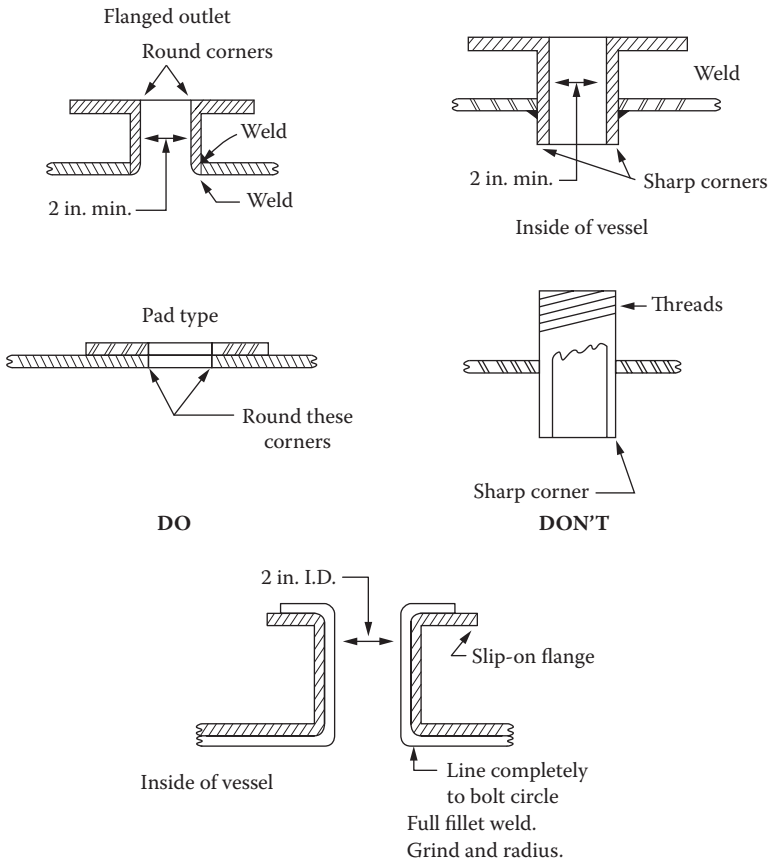

FIGURE 6.6
Typical vessel outlets.

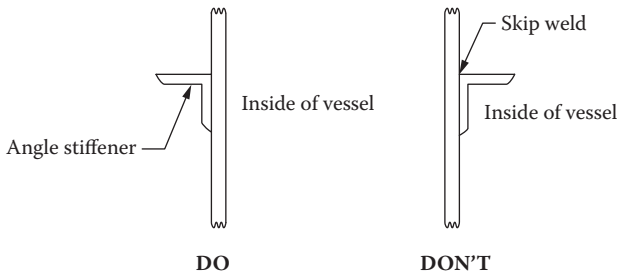

FIGURE 6.7
Stiffening members should be on the outside of the vessel.

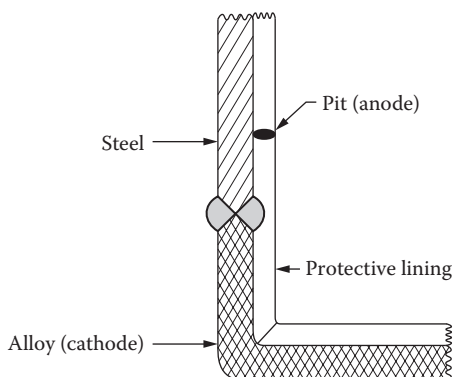

FIGURE 6.8
Potential galvanic action.

completely as well as the steel, thereby eliminating the possible occurrence of a large-cathode-to-small-anode area (see Figure 6.8).

It is important that the processing liquor is not directed against the side of the tank, but rather toward the center. Other appurtenances inside the tank must be located for accessibility of lining. Heating elements should be placed with a minimum clearance of 6 in. Baffles, agitator base plates, pipe, ladders, and other items can either be lined in place or detached and lined before installation. The use of complex shapes such as I-beams should be avoided. Sharp angles should be ground smooth and they should be fully welded. Spot welding or intermittent welding should not be permitted. Gouges, hackles, deep scratches, slivered steel, or other surface flaws should be ground smooth.

Concrete tanks should be located above the water table. They require special lining systems. Unless absolutely necessary, expansion joints should be avoided. Small tanks do not normally require expansion joints. Larger tanks can make use of a chemical-resistant joint such as polyvinyl chloride (PVC). Any concrete curing compound used must be compatible with the lining material or removed before application. Form joints must be made as smooth as possible. Adequate steel reinforcement must be used in a strong, dense, concrete mix to reduce movement and cracking. The lining manufacturer should be consulted for special instructions. Concrete tanks should be lined only by a licensed applicator.

6.1.2 Lining Selection

The primary function of a lining system is to protect the substrate. An equally important consideration is product purity protection. The purity of the liquid must not be contaminated with by-products of corrosion or leachate from the coating itself. Selection of a lining material for a stationary storage tank

dedicated to holding one product at more or less constant time and temperature conditions is relatively easy because such tanks present predictable conditions for coating selection. Conversely, tanks that see intermittent storage of a variety of chemicals or solvents, such as product carriers, present a more difficult problem because the parameters of operation vary. Consideration must be given to the effect of cumulative cargoes. In addition, abrasion resistance must be considered if the product in the tank is changed regularly with complete cleaning required between loadings. Workers and equipment will abrade the lining.

When selecting a coating system, it is necessary to determine all the conditions to which the lining will be subjected. The conditions to consider fall into two categories:

1. Chemicals to which the lining will be exposed
2. Conditions of operation

As a result, it is necessary to verify that the chemical resistance and physical/mechanical properties of the lining are suitable for the application.

To specify a lining material, it is necessary to know specifically what is being handled and under what conditions. The following information must be known about the material being handled:

1. What are the primary chemicals being handled, and at what concentrations?
2. Are there any secondary chemicals? And if so, at what concentrations?
3. Are there any trace impurities or chemicals present? This is extremely important because concentrations in the ppm range can cause serious problems.
4. Are there any solids present? And if so, what are the particle sizes and concentrations?
5. Will there be any agitation?
6. What are the fluid purity requirements?
7. What will be present in the vapor phase above the liquor?

The answers to these questions will narrow the selection to those coatings that are compatible. Following are the more common lining materials and their general area of application:

- *High-bake phenolics*: excellent resistance to acids, solvents, food products, beverages, and water; most widely used lining material but has poor flexibility compared to other lining materials.

- *Modified air-dry phenolics (catalyst required)*: nearly equal in resistance to high-bake phenolics; may be formulated for excellent resistance to alkalis, solvents, salt water, deionized water, fresh water, and mild acids: excellent for dry products.
- *Modified PVC polyvinyl chloroacetals, air-cured*: excellent resistance to strong mineral acids and water; most popular lining for water storage tanks; used in water immersion service (potable and marine) and beverage processing.
- *PVC plastisols*: acid resistant; must be heat cured.
- *Hypalon*: chemical salts.
- *Epoxy (amine catalyst)*: good alkali resistance; fair to good resistance to solvents, mild acids, and dry food product; finds application in covered hopper car linings and nuclear containment facilities.
- *Epoxy polyamide*: good resistance to water and brines; used in storage tanks and nuclear containment facilities; poor acid resistance and fair alkali resistance.
- *Epoxy polyester*: good abrasion resistance; used for covered hopper car linings; poor solvent resistance.
- *Epoxy coal tar*: excellent resistance to mild acids, mild alkalies, salt water, and fresh water; poor solvent resistance; used for crude oil storage tanks, sewage disposal plants, and water works.
- *Coal tar*: excellent water resistance; used for water tanks.
- *Asphalts*: good acid and water resistance.
- *Neoprene*: good acid and flame resistance; used for chemical processing equipment.
- *Polysulfide*: good water and solvent resistance.
- *Butyl rubber*: good water resistance.
- *Styrene-butadiene polymers*: finds application in food and beverage processing and in the lining of concrete tanks.
- *Rubber latex*: excellent alkali resistance; finds application in caustic tanks (50–73%), at 180 to 250°F (82 to 121°C).
- *Urethanes*: superior abrasion resistance; excellent resistance to strong mineral acids and alkalis; fair solvent resistance; used to line dishwashers and washing machines.
- *Vinyl ester*: excellent resistance to strong acids and better resistance up to 350 to 400°F (193 to 204°C), depending on thickness.
- *Vinyl urethanes*: finds application in food processing, hopper cars, and wood tanks.
- *Fluoropolymers*: high chemical resistance and fire resistance; used in SO₂ scrubber service.

- *Vinylidene chloride latex*: excellent fuel oil resistance.
- *Alkyds, epoxy esters, oleoresinous primers*: water immersion applications and as primers for other topcoats.
- *Inorganic zinc, water-based postcure, and water-based self-cure*: Jet fuel storage tanks and petroleum products.
- *Inorganic zinc, solvent-based self-curing*: excellent resistance to most organic solvents (aromatics, ketones, and hydrocarbons); excellent water resistance; difficult to clean; may be sensitive to decomposition products of materials stored in tanks.
- *Furan*: most acid-resistant organic polymer; used for stack linings and chemical treatment tanks.

Answers to the next set of questions will narrow the selection to those materials that are compatible, as well as to those coating systems that have the required physical and/or mechanical properties:

1. What is the normal operation temperature and temperature range?
2. What peak temperatures can be reached during shutdown, startup, process upset, etc.?
3. Will any mixing areas exist where exothermic heat of mixing may develop?
4. What is the normal operating pressure?
5. What vacuum conditions and range are possible during operation, startup, shutdown, and upset conditions?

The size of the vessel must also be considered in coating selection. If the vessel is too large, it may not fit in a particular vendor's oven for curing of the coating. Also, nozzle diameters 4 in. and less are too small to spray-apply a liquid coating. When a coating is to be used for corrosion protection, it is necessary to review the corrosion rate of the immersion environment on the bare substrate. Assuming that the substrate is carbon steel with a corrosion rate of less than 10 mil per year (mpy) at the operating temperature, pressure, and concentration of the corrodent, then a thin film lining of less than 20 mil can be used. For general corrosion, this corrosion rate is not considered severe. However, if a pinhole should be present through the lining, a concentration of the corrosion current density occurs as a result of the large ratio of cathode to anode area. The pitting corrosion rate will rapidly increase above the 20-mpy rate and through-wall penetration will occur in months.

When the substrate exhibits a corrosion rate in excess of 10 to 20 mpy, a thick film coating exceeding 20 mil thickness is used. These thicknesses are less susceptible to pinholes.

Thin linings are used for overall corrosion protection as well as for combating localized corrosion such as pitting and stress cracking of the substrate. Thin fluoropolymer coatings are used to protect product purity and to provide nonstick surfaces for easy cleaning.

Among the materials available for thin coatings are those based on epoxy and phenolic resins that are 0.15 to 0.30 mm (0.006 to 0.012 in.) thick. They are either chemically cured or heat baked. Baked phenolic coatings are used to protect railroad tank cars transporting sulfonic acid. Tanks used to store caustic soda (sodium hydroxide) have a polyamide cured epoxy coating.

Thin coatings of sprayed and baked FEP, PFA, and ETFE are also widely used. They are applied to primed surfaces as sprayed water-borne suspensions or electrostatically charged powders sprayed on a hot surface.

Each coat is baked before the next is applied. Other fluoropolymers can also be applied as thin coatings. These coatings can be susceptible to delamination in applications where temperatures cycle frequently between ambient and steam. Fluoropolymer thin coatings can also be applied as thick coatings.

When the corrosion rate of the substrate exceeds 10 mpy, thick coatings exceeding 25 mil (0.025 in.) are recommended. One such coating is vinyl ester reinforced with glass cloth or woven roving. Coatings greater than 125 mil (0.125 in.) thick can be sprayed or troweled. Maximum service temperature is 170°F (73°C). These coatings can be applied in the field and are used in service with acids and some organics.

Another thick coating material for service with many acids and bases is plasticized PVC. This has a maximum operating temperature of 150°F (66°C).

Sprayed and baked electrostatic powder coatings of fluoropolymers, described under thin coatings, can be applied as thick coatings. One such coating is PVDF and glass or carbon fabric.

Manufacturers and other corrosion engineers should be consulted for case histories of identical applications. Included in the case history should be the name of the applicator who applied the coating, application conditions, type of equipment used, degree of application difficulty, and other special procedures required. A coating with superior chemical resistance will fail rapidly if it cannot be properly applied, so it is advantageous to learn from the experience of others.

To maximize sales, coating manufacturers formulate their products to meet as broad a range as possible of chemical and solvent environments. Consequently, a tank coating may be listed as suitable for in excess of 100 products with varying degrees of compatibility. However, there is a potential for failure if the list is viewed only from the standpoint of the products approved for service.

If more than one of these materials listed as being compatible with the coating is to be used, consideration must be given to the sequence of use in which the chemicals or solvents will be stored or carried in the tank. This is particularly critical when the cargo is water miscible (e.g., methanol or cellosolve) and is followed by a water blast. A sequence such as this creates

excessive softening of the film and makes recovery of the lining more difficult, and thus prone to early failure.

Certain tank coating systems may have excellent resistance to specific chemicals for a given period of time, after which they must be cleaned and allowed to recover for a designated period of time in order to return to their original resistance level. Thirty days is a common period of time for this process between chemicals, such as acrylonitrile and solvents such as methanol.

In some cases, the density of cure can be increased by loading a hot, mildly aggressive solvent at a later date. Ketamine epoxy is such an example. There have been cases where three or four consecutive hot, mild cargoes have increased the density of the lining to such an extent that the ketamine epoxy lining was resistant to methanol. Under normal circumstances, ketamine is not compatible with methanol.

When case histories are not available, or manufacturers are unable to make a recommendation, it will be necessary to conduct tests. This can occur in the case of a proprietary material being handled or if a solution might contain unknown chemicals. Sample panels of several coating systems should be tested for a minimum of 90 days, with a 6-month test being preferable. Because of normal time requirements, 90 days is standard.

The test must be conducted at the maximum operating temperature to which the coating will be subjected and should simulate actual operating conditions, including washing cycles, cold wall, and effects of insulation.

Other factors to consider in coating selection are service life, maintenance cycles, operating cycles, and the reliability of the coating. Different protective coatings provide different degrees of protection for different periods of time at a variety of costs. Allowable downtime of the facility for inspection and maintenance must also be considered, in terms of frequency and length of time.

Once the coating system has been selected, recommendations from the manufacturer as to a competent applicator should be requested and contact made with previous customers.

6.1.3 Lining Application

The primary concern in applying a lining to a vessel is to deposit a void-free film of a specific thickness on the surface. Any area that is considerably less than the specified thickness may leave a noncontinuous film. Additionally, pinholes in the coating may cause premature failure.

Films that exceed the specified thickness always pose the danger of entrapping solvents, which can lead to poor adhesion, excessive brittleness, improper cure, and subsequent poor performance. Avoid dry-spraying of the coating material, as this causes the coating to be porous. If thinners, other than those recommended by the manufacturer are used, poor film formation

may result. Do not permit application to take place below the temperature recommended by the manufacturer.

6.1.4 Cure of the Applied Lining

Proper curing is essential if the lining is to provide the corrosion protection for which it was selected. Each coat must be cured using proper air circulation techniques. To obtain proper air circulation, it is necessary that the tank has at least two openings, one at the top and one at the bottom.

Because most solvents used in lining materials are heavier than air, the fresh air intake will be at the top of the vessel and the exhaust at the bottom. The temperature of the fresh air intake should be higher than 50°F (10°C) with a relative humidity of less than 8%. If possible, the fresh air intake should be fed by forced-air fans.

A faster and more positive cure will be accomplished using a warm, forced-air cure between coats and as a final cure. This will produce a dense film and tighter crosslinking, which provides superior resistance to solvents and moisture permeability.

Before placing the vessel in service, the lining should be washed down with water to remove any overspray. For linings in contact with food products, a final warm, forced-air cure and water wash is essential.

It is important that sufficient time be allowed to permit the lining to obtain a final cure. This usually requires 3 to 7 days. Do not skimp on this time.

When the tank is placed in service, operating instructions should be prepared and should include the maximum temperature to be used. The outside of the tank should be labeled "Do not exceed X°F/X°C. This tank has been lined with Y. It is to be used only for Z service."

6.1.5 Causes of Coating Failure

Most types of failure are the result of the misuse of the tank coating, which results in blistering, cracking, hardening or softening, peeling, staining, burning, and/or undercutting. A frequent cause of failure is overheating during operation. When a heavily pigmented surface or thick film begins to shrink, stresses are formed on the surface and that results in cracks. These cracks do not always expose the substrate and may not penetrate. Under these conditions, the best practice is to remove those areas and recoat according to standard repair procedures.

Aging or poor resistance to the corrosive can result in hardening or softening. As the coating ages, particularly epoxy and phenolic amines, it becomes brittle and may chip from the surface. Peeling can result from improperly cured surfaces, poor surface preparation, or a wet or dirty surface. Staining results when there is a reaction of the corrosive on the surface of the coating or slight staining from impurities in the corrosive. The true cause must be determined by scraping or detergent-washing the surface. If

the stain is removed and softening of the film is not apparent, failure has not occurred.

Any of the above defects can result in undercutting. After the corrosive penetrates to the substrate, corrosion will proceed to extend under the film areas that have not been penetrated or failed. Some coatings are more resistant than others to undercutting or underfilm corrosion. Usually if the coating exhibits good adhesive properties, and if the primer coat is chemically resistant to the corrosive environment, underfilm corrosion will be greatly retarded.

In addition, a tank coating must not impart any impurities to the material contained within it. The application is a failure if any taste, color, smell, or other contamination is imparted to the product, even if the coating is intact. Such contamination can be caused by the extraction of impurities from the coating, leading to blistering between coats or to metal.

If the coating is unsuited for the service, complete failure may occur by softening, dissolution, and finally complete disintegration of the coating. This type of problem is prevalent between the interphase and bottom of the tank. At the bottom of the tank and throughout the liquid phase, penetration is of great concern.

The vapor phase of the tank is subject to corrosion from concentrated vapors mixed with any oxygen present and can cause extensive corrosion.

6.2 Sheet Linings

Designers of tanks and process vessels face the problem of choosing the most reliable material of construction at a reasonable cost. When handling corrosive materials, a choice must often be made between using an expensive material of construction or using a relatively low-cost material from which to fabricate the shell and then installing a corrosion-resistant lining. Carbon steel has been, and still is, the material predominantly selected although there has been a tendency over the past few years to use a fiberglass-reinforced plastic shell. This latter choice has the advantage of providing atmospheric corrosion protection to the shell exterior.

For many years, vessels have been successfully lined with various rubber formulations, both natural and synthetic. Many such vessels have given over 20 years of reliable service.

With the development of newer elastomeric and plastic materials, the variety of lining materials has greatly increased.

The newer materials, particularly the fluorocarbons, have greatly increased the ability of linings to protect substrates from corrosive chemicals. However, for these linings to provide maximum protection, it is important that the vessel shell be properly designed and prepared and the lining properly installed. Unless these precautions are taken, premature failure is likely to occur.

As with any material, the corrosion resistance, allowable operating values, and cost vary with each. Care must be taken when selecting the lining material so that it is compatible with the corrodent being handled at the operating temperatures and pressures required.

6.2.1 Shell Design

The design of the vessel shell is critical if the lining is to perform satisfactorily. For the lining to be installed properly, the vessel must meet certain design configurations. Although these details may vary slightly depending upon the specific lining material used, there are certain design principles that apply in all cases:

1. The vessel must be of butt-welded construction.
2. All internal welds must be ground smooth.
3. All weld spatter must be removed.
4. All sharp corners must be ground to a minimum of 1/8-in. radius.
5. All outlets must be of flanged or pad type. Certain lining materials require that nozzles be not less than 2 in. (51 mm) in diameter.
6. No protrusions are permitted inside the vessel.

Once the lining has been installed, there should be no welding permitted on the exterior of the vessel.

After completing the fabrication, the interior surface of the vessel must be prepared to accept the lining. This is a very critical step. Unless the surface is properly prepared, proper bonding of the lining to the shell will not be achieved. The basic requirement is that the surface be absolutely clean. To ensure proper bonding, all surfaces to be lined should be abrasive-blasted to white metal, in accordance with SSPC specification Tp5-63 or NACE specification 1. A white metal surface condition is defined as being one where all rust, paint, scales, and the like have been removed and the surface has a uniform gray-white appearance. Streaks or stains of rust or other contaminants are not allowed. A near-white, blast-cleaned finish equal to SSPC SP 10 is allowed on occasion. This is a more economical finish. In any case, it is essential that the finish be as the lining contractor has specified. Some lining contractors will fabricate the vessel as well as prepare the surface. When the total responsibility is placed on the lining contractor, the problem is simplified, and a better product will usually result.

When a vessel shell is fabricated from a reinforced thermosetting plastic (RTP), several advantages are realized. The RTPs generally have a wider range of corrosion resistance, but relatively low allowable operating temperatures. When a fluoropolymer-type lining is applied to an RTP shell, the temperature

to which the backup RTP is exposed has been reduced in addition to preventing the RTP from being exposed to the chemicals in the process system. An upper temperature limit for using RTP dual laminates is 350°F (177°C).

The dual laminate construction lessens the problem of permeation through liners. If there is a permeation, it is believed to pass through the RTP structure at a rate equal to or greater than through the fluoropolymer itself, resulting in no potential for collection of permeate at the thermoplastic-to-thermoset interface. If delamination does not occur, permeation is not a problem.

6.2.2 Considerations in Liner Selection

Before selecting a lining material, give careful consideration to several broad categories, specifically materials being handled, operating conditions, and conditions external to the vessel.

The following information must be known about the materials being handled:

1. What are the chemicals being handled and at what concentrations?
2. Are there any secondary chemicals, and if so, at what concentration?
3. Are there any trace impurities or chemicals?
4. Are there any solids present? And if so, what are their particle sizes and concentrations?
5. If a vessel, will there be any agitation, and to what degree? If a pipeline, what are the flow rates (minimum and maximum)?
6. What are the fluid purity requirements?

The answers to the above questions will narrow the selection to those materials that are compatible. This next set of questions will narrow the selection further by eliminating the materials that do not have the required physical or mechanical properties.

1. What is the normal operating temperature and temperature range?
2. What peak temperatures can be reached during shutdown and startup, process upset, etc.?
3. Will any mixing areas exist where exothermic or heat-of-mixing temperatures can develop?
4. What is the normal operating pressure?
5. What vacuum conditions and range are possible during operation, startup, shutdown, or upset conditions?
6. Will there be temperature cycling?
7. What cleaning methods will be used?

Finally, consideration must be given to conditions external to the vessel or pipe:

1. What are the ambient temperature conditions?
2. What is the maximum surface temperature during operation?
3. What are the insulation requirements?
4. What is the nature of the external environment? This can dictate finish requirements and/or affect the selection of the shell material.
5. What are the external heating requirements?
6. Is grounding necessary?

Armed with the answers to these questions, an appropriate selection of liner and shell can be made.

6.2.2.1 Bonded Linings

Bonded linings have several advantages over loose or unbonded linings, including:

1. They have superior performance in vacuum service, resisting collapse to full vacuum if designed properly.
2. During thermal or pressure cycling, bonded linings follow the movement of the structural wall, avoiding stress concentrations at nozzles and other anchor points.
3. There is less permeation for bonded linings than for unbonded linings because permeate must pass through the liner and the substrate.

The construction of adhesive bonded sheet linings on steel substrate consists of fabric-backed sheets bonded to steel vessel walls with neoprene- or epoxy-based adhesive. Liners may be installed in the field or in the shop.

To protect the liner from delamination, a differential expansion or buffer layer is used. This is the bonding layer between the vessel wall and the fabric backing of the liner. Delamination is due primarily to the difference in expansion rates between the structural wall and the lining.

The linear coefficient of a liner free to move would typically be approximately twice that of the structural wall. In any case, the relative stresses set up by the differential expansion of the materials must be determined and the allowable physical properties must not be exceeded.

For process applications that require a lining that will resist harsh chemicals, usually one of the fluoropolymers is selected. Because these linings are expensive, representing 80% of the cost of the vessel, a fabricator must be

TABLE 6.1
Fluoropolymer Sheet Linings (Fabric Backed)

Fluoropolymer	Thickness (mm / mil)
Fluorinated ethylene propylene (FEP)	1.5 / 60
	2.3 / 90
Perfluoroalkoxy (PFA)	1.5 / 60
	2.3 / 90
Ethylene trifluorethylene copolymer (ETFE)	1.5 / 60
	2.3 / 90
Ethylene chlorotrifluorethylene copolymer (ECTFE)	1.5 / 60
	2.3 / 90
Polyvinylidene fluoride (PVDF)	3 / 120
	4 / 160
	5 / 200
	9 / 360

Note: All polymers listed are 1 m wide.

selected that is experienced and knowledgeable in the handling, welding, and forming of the specific fluoropolymer sheet.

Special equipment is also required, such as machines that fuse flat sheets in limited widths into massive sheets, heated forming tools for flanges and fittings, and forming machines that make heads with a minimum number of seams from large sheets. Table 6.1 lists fluoropolymers and the thickness of sheets available.

Seams are fabricated by hot gas welding, extrusion welding, or by butt fusion. It requires considerable skill to hand-fabricate using a rod and hot gas, so the vendor's welders should be checked as to their qualifications. Seams should be minimized. This can be done by using the widest sheet available (3 ft or wider) and by using thermoforming heads instead of pre-formed sections.

6.2.2.2 Unbonded Linings

Loose linings are produced by welding fluoropolymer sheets into lining shapes, folding, and slipping into the housing. The lining is flared over body and nozzle flanges to keep it in place. Weep holes must be provided in the substrate to permit the release of permeants. Vacuum is permitted for diameters up to 12 in. (305 mm). Large vessels cannot tolerate vacuum.

The performance of loose linings in large vessels has only been fair, but they have proven very successful in lined piping.

6.2.3 Design Considerations

In addition to selecting a lining material that is resistant to the corrodent being handled, there are other factors to consider in the design: permeation, absorption, and environmental stress cracking. Permeation and absorption can cause:

1. Bond failure and blistering, resulting from the accumulation of fluids at the bond when the substrate is less permeable than the liner or from corrosion products if the substrate is attacked by the permeant.
2. Failure of the substrate from corrosive attack.
3. Loss of contents through the substrate and lining as the result of the eventual failure of the substrate. In unbonded linings, it is important that the space between the liner and the substrate be vented to the atmosphere, not only to allow minute quantities of permeant vapor to escape, but also to prevent expansion of entrapped air from collapsing the liner.

6.2.3.1 Permeation

All materials are somewhat permeable to chemical molecules but plastic materials tend to be an order of magnitude greater than metals in their permeability. Polymers can be permeated by gases, liquids, or vapors. Permeation is strictly a physical phenomenon; there is no chemical attack on the polymer. It is a molecular migration through either microvoids in the polymer (if the structure is more or less porous) or between polymer molecules.

Permeation is a function of two variables: one relating to diffusion between molecular chains and the other to the solubility of the permeant in the polymer. The driving forces of diffusion are the concentration gradients in liquids and the partial pressure gradient for gases. Solubility is a function of the affinity of the permeant for the polymer.

Material passing through cracks and voids is not related to permeation. These are two distinct happenings. They are not related in any way. Permeation is affected by the following factors:

1. Temperature and pressure
2. Permeant concentration
3. Thickness of the polymer

An increase in temperature will increase the permeation rate because the solubility of the permeant in the polymer will increase, and as the temperature rises, the polymer chain movement is stimulated, permitting more permeants to diffuse among the chain more easily. For many gases, the

permeation rates increase linearly with the partial pressure gradient, and the same effect is experienced with concentration gradients of liquids. If the permeant is highly soluble in the polymer, the permeability increase may not be linear.

The thickness of the polymer affects the permeation. An increase in thickness will generally decrease the permeation by the square of the thickness. However, there are disadvantages to this approach. First, as the lining thickness is increased, thermal stresses on the bond are increased, resulting in bond failure. Temperature changes and large differences in coefficients of thermal expansion are the most common causes of bond failure. The thickness and modulus of elasticity of the lining material are two of the factors that influence these stresses. In addition, as the thickness of the sheet lining material increases, it becomes more difficult to form, and heat may have to be supplied. Also, the thicker sheets are also more difficult to weld. A third factor is cost. As the thickness of the material increases, not only does the material cost more, but the labor cost also increases because of the greater difficulty of working with the material. If polymers such as fluorinated ethylene propylene (FEP), polyvinylidene fluoride (PVDF), or polytetrafluorethylene (PTFE) are being used, the cost may become prohibitive.

The density of the polymer in addition to its thickness will also have an effect on the permeation rate. The higher the specific gravity of the sheet, the fewer the voids that will be present through which permeation can take place. A comparison of the specific gravity between two different polymers will not give an indication of the relative permeation rates. However, a comparison of two liners of the same polymer will provide the difference in the relative permeation rates. The liner having the greater density will have the lower permeation rate.

Other chemical and physiochemical properties affecting permeation are:

1. Ease of condensation of the permeant. Chemicals that readily condense will permeate at higher rates.
2. The higher the intermolecular chain forces (e.g., van der Waals hydrogen bonding) of the polymer, the lower the permeation rate.
3. The higher the level of crystallinity in the polymer, the lower the permeation rate.
4. The greater the degree of crosslinking within the polymer, the lower the permeation rate.
5. Chemical similarity between the polymer and the permeant. When the polymer and the permeant both have similar functional groups, the permeant rate will increase.
6. The smaller the molecule of the permeant, the greater the permeation rate.

The magnitude of any of the effects will be a function of the combination of permeant and polymer in actual service.

6.2.3.2 Absorption

Polymers have the potential to absorb varying amounts of corrodents that they come in contact with, particularly organic liquids. This can result in swelling, cracking, and penetration to the substrate. Swelling can cause softening of the polymer, introduce high stresses, and precipitate failure of the bond. If the polymer has a high absorption rate, permeation will probably take place. An approximation of the expected permeation and/or absorption of the polymer can be based on the absorption of water. This data is usually available. Table 6.2 provides the absorption rates for the more common polymers used for linings.

Failure because of absorption can best be understood by considering the "steam cycle" test described in the ASTM standards for lined pipe. A section of lined pipe is subjected to thermal and pressure fluctuations. This is repeated for 100 cycles. The steam creates a temperature and pressure gradient through the liner, causing absorption of a small quantity of steam that condenses to water within the inner wall. Upon pressure release, or on reintroduction of steam, the entrapped water can expand to vapor, causing an original micropore. The repeated pressure and thermal cycling enlarges the micropores, ultimately producing visible water-filled blisters within the liner.

TABLE 6.2
Water Absorption Rates for Common
Polymers

Polymer	Water Absorption Rate (24 h at 73°F/23°C) (%)
PVC	0.05
CPVC	0.03
PP (Homo)	0.02
PP (Co)	0.03
EHMWPE	<0.01
ECTFE	<0.1
PVDF	<0.04
PFA	<0.03
ETFE	0.029
PTFE	<0.01
FEP	<0.01

In an actual process, the polymer may absorb the process fluids, and repeated temperature or pressure cycling can cause blisters. Eventually, the corrodent may find its way to the substrate.

Related effects can occur when process chemicals are absorbed that may later react, decompose, or solidify within the structure of the plastic. Prolonged retention of the chemicals may lead to their decomposition within the polymer. Although unusual, it is possible for absorbed monomers to polymerize.

Several steps can be taken to reduce absorption. For example, thermal insulation of the substrate will reduce the temperature gradient across the vessel, thereby preventing condensation and subsequent expansion of the absorbed fluids. This also reduces the rate and magnitude of temperature changes, keeping blisters to a minimum. The use of operating procedures or devices that limit the ratio of process pressure reductions or temperature increases will provide additional protection.

6.2.4 Inspection of the Lining

Scheduling the inspection of the liner and installation in the vessel should be arranged so that timely inspections can be made at various stages. The following items should be inspected:

1. Liner fit-up and preparation for welding. Fusion welded seams may be made prior to application of the liner to the mold in the case of an RTP shell.
2. In the case of an RTP structural shell, the liner welds should be inspected on the mold prior to application of the RTP shell. All welds should be checked visually and with a spark tester. If the mold is not of metal construction, conductive back-up material must be placed on the mold behind the seams.
3. If the structural shell is to be of RTP construction, it is necessary that conductive resin ground strips be placed over the back side of the seams so that the liner can be spark tested after the structural laminate has been applied. The resin ground strips are made from resin, filled with carbon powder applied as a putty, or are resin reinforced with carbon cloth laid up over the seams. This provides sufficient electrical conductivity to create a ground for the spark. When a steel shell is to be used, the strips are unnecessary because the steel shell will act as a ground for the spark.
4. Application of the prime coat to the back of the liner.
5. With an RTP shell, fit-up of the components of the vessel. This includes head-to-shell, nozzles to heads and shell, and shell joints. Alignment is more critical in a lined vessel than in an unlined one.

6. When butt fusion joints are to be used inside the shell, the preparation for these welds should be inspected.
7. Hydrostatic and thermal cycling tests.
8. Halide tests.
9. Final spark testing of the seams prior to shipping.

Additional inspections may be required if the vessel has special features such as internal support ledges or pipe supports that may require hand welding of components.

When preparing for shipment, flange covers should be shipped in place. Flanges or pads that do not have covers should be protected with temporary covers securely fastened in place.

6.2.5 Causes of Lining Failure

Linings, if properly selected, installed, and maintained, and if the vessel has been properly designed, fabricated, and prepared to accept the lining, promise many useful years of service. However, on occasion, there have been lining failures that can be attributed to one or more of the following causes.

6.2.5.1 Liner Selection

Selection is the first step. Essential to this step is a careful analysis of the materials being handled, their concentrations, and operating conditions as outlined in the beginning of this chapter. Consideration must also be given to the physical and mechanical properties of the liner to ensure that it meets the specified operating conditions. If there is any doubt, corrosion testing should be undertaken to guarantee the resistance of the liner material.

6.2.5.2 Inadequate Surface Preparation

Surface preparation is extremely important. All specifications for surface preparation must be followed. If not done properly, poor bonding can result and/or mechanical damage to the liner is possible.

6.2.5.3 Thermal Stresses

If not properly designed for, thermal stresses produced during thermal cycling can eventually result in bond failure.

6.2.5.4 Permeation

Certain lining materials are subject to permeation when in contact with specific corrodents. When the possibility of permeation exists, an alternate

lining material should be selected. Permeation can result in debonding resulting from corrosion products or fluids accumulating at the interface between liner and substrate. In addition, corrosion of the substrate can result, leading to leakage problems and eventual failure of the substrate.

6.2.5.5 Absorption

As with permeation, absorption of the corrodent by the liner material can result in swelling of the liner, cracking, and eventual penetration to the substrate. This can lead to high stresses and debonding.

6.2.5.6 Welding Flaws

It is essential that qualified personnel perform the welding and that only qualified, experienced contractors be used to install linings. A welding flaw is a common cause of lining failure.

6.2.5.7 Debonding

Debonding can occur as a result of the use of the wrong bonding agent. Care should be taken that the proper bonding agent is employed for the specific lining being used.

6.2.5.8 Operation

Lined vessels should be properly identified when installed with the allowable characteristics of the liner posted to avoid damage to the liner during clean-up or repair operations. Most failures from this cause result while vessels are being cleaned or repaired. If live steam is used to clean the vessel, allowable operation temperatures may be exceeded. If the vessel is solvent cleaned, then chemical attack may occur.

6.2.5.9 Environmental Stress Cracking

Stress cracks develop when a tough polymer is stressed for an extended period of time under loads that are small relative to the polymer's yield point. Cracking will occur with little elongation of the material. The higher the molecular weight of the polymer, the less likelihood of environmental stress cracking, other things being equal. Molecular weight is a function of the length of individual chains that make up the polymer. Longer chain molecules tend to crystallize less than polymers of lower molecular weight or shorter chains, and they also have a greater load-bearing capacity.

Crystallinity is an important factor affecting stress corrosion cracking. The less crystallization that takes place, the less the likelihood of stress crack-

ing. Unfortunately, the lower the crystallinity, the greater the likelihood of permeation.

Resistance to stress cracking can be reduced by the absorption of substances that chemically resemble the polymer and will plasticize it. In addition, the mechanical strength will also be reduced. Halogenated chemicals, particularly those consisting of small molecules containing chlorine or fluorine, are especially likely to be similar to the fluoropolymers and should be tested for their effect.

The presence of contaminants in a fluid may act as an accelerator. For example, polypropylene can safely handle sulfuric or hydrochloric acids, but iron or copper contamination in concentrated sulfuric or hydrochloric acids can result in the stress cracking of polypropylene.

6.3 Elastomeric Linings

Elastomers, sometimes referred to as rubbers, have given many years of service in providing protection to steel vessels. Each of these materials can be compounded to improve certain of its properties. Because of this, it is necessary that a complete specification for a lining using these materials includes specific properties that are required for the application. These include resilience, hysteresis, static or dynamic shear and compression modulus, flex fatigue and cracking, creep resistance to oils and chemicals, permeability, and brittle point, all in the temperature range to be encountered in service. This will permit a competent manufacturer to propose the proper lining material for the application.

Elastomeric linings are sheet-applied and bonded to the steel substrate. The choice of bonding material to be used depends on the specific elastomer to be installed. Repair of these linings is relatively simple. Many older vessels with numerous repair patches are still operating. The same general rules apply for the design, fabrication, and preparation of the steel shell for lining that apply for other sheet linings.

The most common elastomers used for lining applications, along with their operating temperature range, are given in Table 6.3.

Elastomeric materials can fail as the result of chemical action and/or mechanical damage. Chemical deterioration occurs as the result of a chemical reaction between an elastomer and the medium or by the absorption of the medium into the elastomer. This attack results in the swelling of the elastomer and a reduction in its tensile strength.

The degree of deterioration is a function of the temperature and the concentration of the corrodent. In general, the higher the temperature and the higher the concentration of the corrodent, the greater will be the chemical attack. Elastomers, unlike metals, absorb varying quantities of the material they are

TABLE 6.3

Elastomers Used as Liners

Elastomer	Temperature Range			
	°F		°C	
	Minimum	Maximum	Minimum	Maximum
Natural rubber, NR	-39	175	-50	80
Butyl rubber, IR	-30	300	-34	149
Chlorobutyl rubber, CIIR	-30	300	-34	149
Neoprene, CR	-13	203	-25	95
Hypalon, CSM	-20	250	-30	121
Urethane rubber, AU	-65	250	-54	121
EPDM rubber	-65	300	-54	149
Nitrile rubber, NBR, Buna-N	-40	250	-40	121
Polyester elastomer, PE	-40	302	-40	150
Perfluoroelastomers, FPM	-58	600	-50	316
Fluoroelastomers, FKM	-10	400	-18	204

in contact with, especially organic liquids. This can result in swelling, cracking, and penetration to the substrate of an elastomeric-lined vessel. Swelling can cause softening of the elastomer, and in a lined vessel, introduce high stresses and failure of the bond. If an elastomeric lining has high absorption, permeation will probably result. Some elastomers, such as the fluorocarbons, are easily permeated but have very little absorption. An approximation of the expected permeation and/or absorption of an elastomer can be based on the absorption of water. These data are usually available.

7

Corrosion of Paint

Organic coatings are widely used to protect metal surfaces from corrosion. The effectiveness of such coatings depends not only on the properties of the coatings that are related to the polymeric network, and possible flaws in the network, but also on the character of the metal substrate, the surface pre-treatment, and the application procedures. Therefore, when considering the application of a coating, it is necessary to take into account the properties of the entire system.

There are three broad classes of polymeric coatings: lacquers, varnishes, and paints. Varnishes are materials that are solutions of either a resin alone in a solvent (spirit varnishes) or an oil and resin together in a solvent (oleo-resinous varnishes). A lacquer is generally considered a material whose basic film former is nitrocellulose, cellulose acetate-butylate, ethyl cellulose, acrylic resin, or another resin that dries by solvent evaporation. The term "paint" is applied to more complex formulations of a liquid mixture that dries or hardens to form a protective coating.

Paints or coatings, if used primarily for corrosion protection, are something that everyone is familiar with to some degree. Paint can be seen no matter where one looks. Paint can be seen on furniture, houses, automobiles, trucks, ships, airplanes, bridges, chemical plants, nuclear power plants, literally everywhere. Paint is used for a variety of purposes; for example, in the house alone, paints can be used to provide an aesthetically appealing interior and a protective durable exterior, to provide mildew and rot resistance to wood, to seal masonry from water, and to seal the substrate and improve sanitation and cleanup in such places as the bathroom and kitchen.

The reason for the widespread use of paint and coatings is the fact that they are relatively inexpensive; provide good gloss, color, and decorative effects; while also providing protection from the effects of the environment. Also important is the fact that paints are readily available and can be applied by a variety of methods, ranging from simple brush and roller to the rather sophisticated automated finishing lines employing electrostatic spray, fluidized bed (for powder coatings), oil coating and baking lines, and other technically complex application methods. Of all the corrosion protection methods employed, painting and protection by coatings is the most widely used.

Coating for corrosion protection should be considered an engineering function, consisting of design considerations, selection of a suitable coating system, surface preparation requirements, coating application considerations (including control of ambient conditions during application), certain special

considerations (such as thickness variances for application condition, substrate condition), and finally scheduled inspection and maintenance.

Organic coatings can protect metal structures against a specific or otherwise corrosive environment in a relatively economical way. The degree of protection depends on a number of properties of the total coated system, which consists of paint film, metal substrate, and its pretreatment.

Paints and coatings are based on naturally occurring compounds, synthetic materials, or a mixture of both. The natural type systems are based on asphaltic, bituminous materials or on natural oils, such as those produced from rice, fish, etc. The latter group is composed of the original "oleo-resinous" paints although the term has a much broader meaning today. The older systems are much more tolerant of poor surface preparation and contamination than the more modern synthetic paints.

Painting systems are classified according to the generic type of binder or resin, and are grouped according to the curing or hardening mechanism inherent in that generic type. Although the resin or organic binder of the coating material has the predominant effect on the resistances and properties of the paint, the type and quantity of pigments, solvents, and additives have an influence on the application properties and protective ability of the applied film. In addition, systems can be formulated that are crosses between categories. For example, the acrylic monomer or prepolymer can be incorporated with practically any other generic resin to produce a product having properties that are a compromise between the acrylic and original polymer.

Modern synthetic coatings are based on a variety of chemistries. They usually require more sophisticated surface preparation and application than the natural type systems.

Today's paints and coatings must be in compliance with volatile organic compound (VOC) restrictions and U.S. OSHA regulations. Some states and local municipalities have imposed even stricter limits.

7.1 Mechanisms of Protection

Organic coatings provide protection either by formation of a barrier action from the layer or from active corrosion inhibition provided by pigments in the coating. In actual practice, the barrier properties are limited because all coatings are permeable to water and oxygen to some extent. The average transmission rate of water through a coating is about 10 to 100 times larger than the water consumption rate of a freely flowing surface, and in normal outdoor conditions, an organic coating is saturated with water at least half of its service life. For the remainder of the time, it contains a quantity of water comparable to its behavior in an atmosphere of high humidity. Table 7.1 shows the diffusion data for water through organic films.

TABLE 7.1

Diffusion Data for Water through Organic Films

Polymer	Temperature (°C)	P × 10 ⁹ (cm ² /sec cmHg)	D × 10 ⁹ (cm ² /s)
Epoxy	25	10–44	2–8
	40	—	5
Phenolic	25	166	0.2–10
Polyethylene (low density)	25	9	230
Polymethylmethacrylate	50	250	130
Polyisobutylene	30	7–22	—
Polystyrene	25	97	—
Polyvinyl acetate	40	600	150
Polyvinyl chloride	30	13	16
Vinylidene chloride/ acrylonitrile copolymer	25	1.7	0.32

P = permability coefficient

D = diffusion coefficient

Source: From Leidheiser Jr., H., 1987, *Coatings in Corrosion Mechanisms*, Mansfield, F., Ed., New York: Marcel Dekker, p. 165–209.

It has also been determined that in most cases, the diffusion of oxygen through the coating is large enough to allow unlimited corrosion. Taking these factors into account indicates that the physical barrier properties alone do not account for the protective actions of coatings. Table 7.2 shows the flux of oxygen through representative free films of paint 100- μ m thick.

TABLE 7.2Flux of Oxygen through Representative Free Films of Paint, 100 μ m Thick

Paint	J (mg/cm ² ·day)
Alkyd (15% PVC Fe ₂ O ₃)	0.0069
Alkyd (35% PVC Fe ₂ O ₃)	0.0081
Alkyl melamine	0.001
Chlorinated rubber (35% PVC Fe ₂ O ₃)	0.017
Cellulose acetate	0.026 (95% RH)
Cellulose nitrate	0.115 (95% RH)
Epoxy melamine	0.008
Epoxy coal tar	0.0041
Epoxy polyamide (35% PVC Fe ₂ O ₃)	0.0064
Vinyl chloride/vinyl acetate copolymer	0.004 (95% RH)

Source: From Leidheiser Jr., H., 1987, *Coatings in Corrosion Mechanisms*, Mansfield, F., Ed., New York: Marcel Dekker, p. 165–209.

Additional protection may be supplied by resistance inhibition, which is also a part of the barrier mechanism. Retardation of the corrosion action is accomplished by inhibiting the charge transport between cathodic and anodic sites. The reaction rate may be reduced by an increase in the electrical resistance and/or the ionic resistance in the corrosion cycle. Applying an organic coating on a metal surface increases the ionic resistance. The electronic resistance can be increased by the formation of an oxide film on the metal. This is the case for aluminum substrates.

Corrosion of a substrate beneath an organic coating is an electrochemical process that follows the same principles as corrosion of an uncoated substrate. It differs from crevice corrosion because the reactants often reach the substrate through a solid. In addition, during the early stages of corrosion, small volumes of liquid are present, resulting in extreme values of pH and ion concentrations.

The total corrosion process takes place as follows:

1. Migration through the coating of water, oxygen, and ions
2. Development of an aqueous phase at the coating/substrate interface
3. Activation of the substrate surface for the anodic and cathodic reactions
4. Deterioration of the coating/substrate interfacial bond

7.2 Composition of Paint

Paints are broadly classified as primers and topcoats. Primers are applied directly to a metal surface. They contain pigments of zinc and perform the primary job of corrosion protection. Topcoats are applied over the primer mainly for the sake of appearance. However, they also provide a diffusion barrier and close the pores in the primary coat. Pores, or “holidays,” are the starting point of paint failures. The application of topcoat minimizes these potential points of failure. Three to five topcoats are often recommended for industrial and marine atmospheres.

The composition of a coating (paint) determines the degree of corrosion protection that will be supplied. A paint formulation is made up of four general classes of ingredients: vehicle (binder, resin component), pigment, filler, and additive. It is the combination of these ingredients that imparts the protective properties to the coating.

7.2.1 Binder

The binder (or resin) forms the matrix of the coating, the continuous polymeric phase in which all other components can be incorporated. The resin is

the film-forming agent of the paint. Its density and composition are primarily responsible for determining the permeability, corrosion resistance, and ultraviolet (UV) resistance of the coating.

A continuous film is formed either by physical curing, chemical curing, or a combination of the two. A typical physical curing process is the sintering of thermoplastic powder coatings. Prior to application, this type of paint consists of a large number of small binder particles. After depositing these particles on a metal surface, they are baked in an oven to form a continuous film by sintering.

Chemical curing involves film formation through chemical reaction. These reactants can either be reactive curing or oxidative curing. In reactive curing, a polymer network is formed through polycondensation or polyaddition reactions. This may be the case with multicomponent coatings where the binder reacts with crosslinkers. In oxidative curing, oxygen from the atmosphere reacts with the binder monomers, causing polymerization.

It is not uncommon for both physical and chemical curing to take place, as in the case with the film formation of thermosetting powders. At elevated temperatures, physical sintering of the particles takes place, followed by chemical reaction between different components in the powder. Another example is film formation of solvent-based reactive coatings, such as common house paints. With these paints, the solvent physically evaporates from the curing film, causing the binder molecules to coalesce and start chemical polymerization reactions.

7.2.2 Pigments

The addition of pigments serves two purposes. First, pigments provide color to the coating system to improve its aesthetic appeal, and second, they can be added to improve the corrosion-protection properties of the coating. This latter improvement can be obtained, for example, by incorporating flake-shaped pigments parallel to the substrate surface. When a large volume concentration is used, the flakes will hinder the permeation of corrosive media into the coating by elongating their diffusion pathways.

Alternatively, anti-corrosion pigments can be added that will provide active protection against corrosive attack. These pigments tend to dissolve slowly in the coating and provide protection by covering corrosion-sensitive sites under the coating by sacrificially corroding themselves, thereby protecting the substrate metal, or by passivating the surface.

Blocking pigments can adsorb at the metal surface, thereby reducing the active area for corrosion and forming a transport barrier for ionic species to and from the substrate. Typical of this type is a group of alkaline pigments such as lead carbonate, lead sulfate, and zinc oxide. These can form soaps via interaction with organic oils.

Galvanic pigments are metal particles that are not noble related to the metal substrate. On exposure, these particles (zinc dust on steel) corrode

preferentially, while at the original metal surface only the cathodic reaction takes place.

Passivating pigments reconstruct and stabilize the oxide film on the exposed metal substrate. Chromates (e.g., zinc chromate, strontium chromate) with limited water solubility are used for this purpose. In aqueous systems, they may cause anodic passivation of a metal surface with a very stable chromium and oxygen containing layer.

Color or hiding pigments are selected to provide aesthetic value, retention of gloss and color, as well as help with film structure and impermeability. Examples include iron oxides, titanium dioxide, carbon or lampblack, and others.

Pigments must be compatible with the resin and should also be somewhat resistant to the environment; for example, calcium carbonate, which is attacked by acid, should not be used in an acidic environment. Water-soluble salts are corrosion promoters, so that special low-salt-containing pigments are used as primers for steel.

For special protective properties, primers contain one of three kinds of pigments:

1. *Inert or chemically resistant pigment.* These are for use in barrier coatings in severe environments, such as conditions below an acidity of pH 5 or above an alkalinity of pH 10, or as a nonreactive extender, hiding or color pigments in neutral environments.
2. *Active pigment.* Leads, chromates, or other inhibitive pigments are used in linseed oil/alkyd primers.
3. *Galvanically sacrificial pigment.* Zinc is employed at high concentrations to obtain electrical contact for galvanic protection in environments between pH 5 and 10.

Types and characteristics of these pigments are presented in Table 7.3.

7.2.3 Solvents

The purpose of a solvent is to reduce the viscosity of the binder and other components so as to enable their homogeneous mixing. In addition, the reduced viscosity makes it possible to apply the coating as a thin, smooth, continuous film on a specific surface. The roles of a solvent in a coating prior to application and after application are contradictory. In the liquid state, before application, paint should form a solution or a stable dispersion or emulsion of binder, pigments, and additives in the solvent. All solid components should remain more or less homogeneously distributed in the liquid phase. This requires high compatibility between solvents and components and the presence of repulsive forces between solvents and components to avoid clustering. In contrast, after applying the paint, a major attractive force

TABLE 7.3

Characteristics of Pigments for Metal Protective Paints

Pigment	Specific Gravity	Color	Opacity	Specific Contribution to Corrosion Resistance
<i>Active Pigments</i>				
Red lead	8.8	Orange	Fair	Neutralizes film acids Insolubilizes sulfates and chlorides Renders water noncorrosive
Basic silicon lead chromate	3.9	Orange	Poor	Neutralizes film acids Insolubilizes sulfates and chlorides Renders water noncorrosive
Zinc yellow (chromate)	3.3	Yellow	Fair	Neutralizes film acids Anodic passivator Renders water noncorrosive
Zinc oxide (French process)	5.5	White	—	Neutralizes film acids Renders water noncorrosive
Zinc dust at low concentration in coatings for steel	7.1	Gray	Good	Neutralizes film acids
<i>Galvanically Protective Pigments</i>				
Zinc dust sacrificial at high concentrations	7.1	Gray	Good	Makes electrical contact Galvanically sacrificial
<i>Barrier Pigments</i>				
Quartz	2.6	Nil	Translucent	Inert Compatible with vinyl ester additives
<i>Extenders</i>				
Mica	2.8	Nil	Translucent	Impermeability and inertness
Talc	2.8	Nil	Translucent	Impermeability and inertness
Abestine	2.8	Nil	Translucent	Impermeability and inertness
Baytes	4.1	Nil	Translucent	Impermeability and inertness
Silica	2.3	Nil	Translucent	Impermeability and inertness
Iron oxide	4.1	Red	—	Impermeability and inertness
Iron oxide	4.1	Ochre	—	Impermeability and inertness
Iron oxide	4.1	Black	—	Impermeability and inertness
Titanium dioxide	4.1	White	Excellent	Impermeability and inertness
Carbon black	1.8	Black	Good	Impermeability and inertness

Note: Titanium dioxide has better "hiding" than any other pigment.

Source: Tator, K.B., 1989, Coating, in *Corrosion and Corrosion Protection Handbook*, 2nd. ed., Schweitzer, P.A., Ed., New York: Marcel Dekker, p. 466–467.

between the components is necessary for the formation of a continuous film. The interaction with the solvent should decrease to enable the solvent to evaporate from the curing film. To achieve optimum storage and application properties, a correct choice of additives is vital. Correct material selection for coating formulation is often a complicated operation where elaborate practical experience is a requirement.

Organic solvents (water is considered either a solvent or an emulsifier) usually are required only to apply the coating and, after the application, are designed to evaporate from the wet paint film. The rate at which the solvents evaporate strongly influences the application characteristics of the coating; and if the solvents are partially retained and do not completely evaporate, quite often the coating will prematurely fail due to blistering and pinholing. As a general rule, the synthetic resins (vinyls, epoxies, chlorinated rubbers, etc.) are more polar and therefore more readily dissolve in polar solvents. However, polar solvents are more apt to be retained by a polar resin system and therefore, when using such resins, particularly in immersion service, it is imperative that sufficient time is allowed for the coating to dry. Because these resins depend more on solvents for penetration and flow, they require a greater degree of surface preparation than do oleoresinous or oil-modified coatings.

Coatings usually are formulated to be applied at ambient conditions of approximately 75°F (24°C) and 50% relative humidity. If ambient conditions are considerably higher or lower than these optimum ranges, then the solvent balance should be modified to provide for better coating application and solvent release. In colder weather, faster evaporating solvents should be used; and conversely, in hot weather, slower evaporating solvents are required. Classes and characteristics of some common solvents are given in Table 7.4.

In some cases, organic paint can be mixed and applied without the presence of solvents. These paint systems are referred to as "solvent free." Examples of these are low-viscosity, two-component epoxies and powder coatings. The application and curing of powder coatings were discussed previously. The epoxy coatings can be mixed and applied without the use of a solvent, as the two components typically have low viscosity. Mixing and application of these coatings are often done at elevated temperatures to reduce the viscosity as much as possible.

7.2.4 Additives

Most additives are formulated into paint often in trace amounts to provide a specific function. For example, cobalt and manganese naphthanates are used as dryers for alkyds and oil-based coatings to facilitate surface and thorough drying. These drying additives are added to the paint in amounts usually less than 0.01%.

Other additives are incorporated into the formula for different purposes. For example, zinc oxide can be added to retard deterioration of the resin by

TABLE 7.4
Characteristics of Solvent Classes

Class	Solvent Name	Strength/ Solventy	Polarity	Specific Gravity	Boiling Range (°F)	Flash Point of TCC	Evaporation Rate ^a
Aliphatic	VM & P naphtha	Low (32 KB) ^b	Nonpolar	0.74	246–278	52	24.5
	Mineral spirits	Low (28 KB)	Nonpolar	0.76	351–395	128	9.0
Aromatic	Toluene	High (105 KB) ^c	Intermediate	0.87	230–233	45	4.5
	Xylene	High (95 KB)	Intermediate	0.87	280–288	80	9.5
Ketone	High solventy	High (90 KB)	Intermediate	0.87	360–400	140	11.6
	Methyl ethyl ketone (MEK)	Strong	High	0.81	172–176	24	2.7
	Methyl isobutyl ketone (MIBK)	Strong	High	0.80	252–266	67	9.4
	Cyclohexanone	Strong	High	0.95	313–316	112	4.1
Ester	Ethyl acetate	Intermediate	Intermediate	0.90	168–172	26	2.7
Alcohol	Ethanol	Weak	Intermediate	0.79	167–178	50	6.8
	Unsaturated aromatic	Strong	Intermediate	0.90			
Glycol ethers	Styrene	Strong	High	0.93	273–277	110	0.3
	Cellosolve	Strong	High	0.90	336–343	137	0.06
	Butyl cellosolve	Strong	High	0.90			

^a Butyl acetate equals 1.

^b KB, Kauri-Butanol, a measure of solvent power of petroleum thinners (milliliters of thinner required to produce cloudiness when added to 20 g of a solution of karigum in butyl alcohol).

^c TCC-TAE closed cup.

Source: Schweitzer, Philip A., 2006, *Paints and Coatings*, Boca Raton, FL: Taylor & Francis, p. 94.

heat and actinic rays of the sun. Mildew inhibitors (phenylmercury, zinc, and cuprous compounds) are commonly added to oil-based and latex paints. Latex paints (water emulsion) invariably have a number of additives acting as surfactants, coalescing aids, emulsion stabilizers, etc. Vinyl paints often have a 1% carboxylic acid (generally maleic acid) modification to the vinyl resin to promote adhesion to metals. Conversely, hydroxyl modification (generally an alcohol) aids in adhesion of vinyls to organic primers. The use of a particular additive can be critical to the performance of the paint; and because additives are usually added in trace amounts, they may be most difficult to detect upon analysis of the paint.

7.2.5 Fillers (Extenders)

The primary function of fillers in organic coatings is to increase the volume of the coating through the incorporation of low-cost materials such as chalk or wood dust. They may also be used to improve coating properties such as impact and abrasion resistance and water permeability.

In addition to lowering the cost, extenders also provide sag resistance to the liquid paint so that the edges remain covered. When the paint has dried, they reduce the permeability to water and oxygen and provide reinforcing structure within the film. Talc and mica are used extensively as extenders. Mica is limited to approximately 10% of the total pigment. Both talc and mica, but particularly mica, reduce permeability through the film as plate-like particles block permeation, forcing water and oxygen to seek a longer path through the binder around the particle.

7.3 Causes of Bond and Coating Failures

Bond and coating failures can result from any one or a combination of the following causes:

1. Poor or inadequate surface preparation and/or application of the paint to the substrate
2. Atmospheric effects
3. Structural defects in the paint film
4. Stresses between the bond and the substrate
5. Corrosion

7.3.1 Surface Preparation and Application

Coating failures typical of surface preparation and application problems include:

1. *Cracking, chalking, alligating.* These types of failure develop with the aging of the paint film. Shrinkage within the film during aging causes cracking and checking. Alligating is a film rupture, usually caused by application of a hard, brittle film over a more flexible film.
2. *Peeling, flaking, delamination.* These failures are caused by poor adhesion. When peeling or flaking occurs between coats, it is called delamination.
3. *Rusting.* Failure of a coated surface may appear as (a) spot rusting in minute areas, (b) pinhole rusting in minute areas, (c) rust nodules breaking through the coating, or (d) underfilm rusting, which eventually causes peeling and flaking of the coating.
4. *Lifting and wrinkling.* When the solvent of a succeeding coat of paint too rapidly softens the previous coat, lifting results. Rapid surface drying of a coating without uniform drying throughout the rest of the film results in a phenomenon known as wrinkling.
5. *Failures around weld areas.* Coating adhesion can be hampered by weld flux, which can also accelerate corrosion under the film. Relatively large projections of weld spatter cause possible gaps and cavities that may not be coated sufficiently to provide protection.
6. *Edge failures.* Edge failures usually take the form of rusting through the film at the edge where the coating is usually the thinnest. This is usually followed by eventual rust seepage under the film.
7. *Pinholing.* These are tiny holes that expose the substrate, and are caused by improper spray atomization or segregation of resin in the coating. If practical during application, brush out the coating. After application and proper care, apply additional coating.

7.3.2 Atmospheric Effects

Polymeric coatings are exposed to environmental constituents. The primary factors promoting degradation are thermal, mechanical, radiant, and chemical in nature. Polymers can also be degraded by living organisms such as mildew. Any atmospheric environment is subject to dry and wet cycles. Because water and moisture have a decided effect on the degradation of a coating, the duration of wetness of a coating is important. Moisture and water that attack organic films derive from rain, fog, dew, snow, and water vapors in the atmosphere. Relative humidity is a particularly important factor. As expo-

TABLE 7.5

Relationship of Bond Strength to Exposure Time in 100% Relative Humidity

Exposure Time (hr)	Bond Strength (psi)		
	Epoxy Ester	Polyurethane	Thermosetting Acrylic
Initial	4790	3410	5700
24	1640	1500	3650
48	1500	1430	3420
128	—	1390	2400
195	1400	1130	1850
500	1390	670	480

sure time is increased in 100% relative humidity, the bond strength of the paint coating is reduced. This is shown in Table 7.5.

Temperature fluctuations and longer durations of wetness tend to produce clustered water, which increases the acceleration of degradation of the organic film, particularly in a marine atmosphere. The most severe natural atmosphere for a paint film is that of a seashore environment.

The mode of degradation may involve depolymerization, generally caused by heating, splitting out of constituents in the polymer, chain scission, cross-linking, oxidation, and hydrolysis. Polymers are subject to cracking upon application of a tensile force, particularly when exposed to certain liquid environments. This phenomenon is known as environmental stress cracking or corrosion cracking.

Polymeric materials in outdoor applications are exposed to weather extremes that can be deleterious to such materials. The most harmful weather component, exposure to ultraviolet (UV) radiation, can cause embrittlement, fading, surface cracking, and chalking. After exposure to direct sunlight for a period of years, most polymers exhibit reduced impact resistance, lower overall mechanical performance, and a change in appearance.

The electromagnetic energy of sunlight is normally divided into ultraviolet (UV) light, visible light, and infrared energy. Infrared energy consists of wavelengths longer than visible red wavelengths and starts above 760 nanometers (nm). UV light consists of radiation below 400 nm. The UV portion of the spectrum is further subdivided into UV-A, UV-B, and UV-C. The effects of various wavelengths are shown in Table 7.6.

Because UV light is easily filtered by air masses, cloud cover, pollution, and other factors, the amount and spectrum of natural UV exposure is extremely variable. Because the sun is lower in the sky during the winter months, it is filtered through greater air masses. This creates two important

TABLE 7.6

UV Wavelength Region Characteristics

Region	Wavelength (nm)	Characteristics
UV-A	400–315	Causes polymer damage
UV-B	315–200	Includes the shortest wavelengths found at the Earth's surface Causes severe polymer damage Absorbed by window glass
UV-C	280–100	Filtered out by the Earth's atmosphere Found only in outer space

differences between summer and winter daylight hours. During the winter months, much of the damaging short-wavelength UV light is filtered out. For example, the intensity of UV light at 320 nm changes about 8 to 1 from summer to winter. In addition, that short-wavelength solar cutoff shifts from approximately 295 nm in summer to approximately 310 nm in winter. As a result, materials sensitive to UV below 320 nm would degrade only slightly, if at all, during the winter months.

Photochemical degradation is caused by photons or light breaking chemical bonds. For each type of chemical bond, there is a critical threshold wavelength of light with enough energy to cause a reaction. Light of any wavelength shorter than the threshold can break a bond, but longer wavelengths of light cannot break it. Therefore, the short-wavelength cutoff of a light source is of critical importance. If a particular polymer is sensitive only to light below 295 nm (the solar cutoff point), it will never experience photochemical deterioration outdoors.

The ability to withstand weathering varies with the polymer type and within grades of a particular resin. Most resin grades are available with UV-absorbing additives to improve weatherability. However, the higher-molecular-weight grades of a resin generally exhibit better weatherability than the lower-molecular-weight grades with comparable additives. In addition, some colors tend to weather better than others.

Several artificial light sources have been developed to simulate direct sunlight. In the discussion of accelerated weathering light sources, the problems of light stability, the effects of moisture and humidity, the effects of cycles, or the reproducibility of results are not taken into account. Simulations of direct sunlight should be compared to what is known as the solar maximum condition — global moon sunlight on the summer solstice at normal incidence. The most severe condition that can be encountered in outdoor service is the solar maximum, which controls the failure of materials. It is misleading to compare light sources against “average optimum sunlight,” which is an average of the much less damaging March 21 and September 21 equinox readings.

7.3.3 Types of Failures

Factors in the atmosphere that cause corrosion or degradation of the coating include UV light, temperature, oxygen, ozone, pollutants, and wind. The types of failures resulting from these causes include:

1. *Chalking*. UV light, oxygen, and chemicals degrade the coating, resulting in chalk. This can be corrected by providing an additional topcoat with the proper UV inhibitor.
2. *Color fading or color change*. This can be caused by chalk on the surface or by breakdown of the colored pigments. Pigments can be decomposed or degraded by UV light or reaction with chemicals.
3. *Blistering*. Blistering may be caused by:
 - a. Inadequate release of solvent during both application and drying of the coating system
 - b. Moisture vapor that passes through the film and condenses at a point of low paint adhesion
 - c. Poor surface preparation
 - d. Poor adhesion of the coating to the substrate or poor intercoat adhesion
 - e. A coat within the paint system that is not resistant to the environment
 - f. Application of a relatively fast drying coating over a relatively porous surface
 - g. Failure due to chemical or solvent attack (when a coating is not resistant to its chemical or solvent environment, there is apparent disintegration of the film)
4. *Erosion (coating worn away)*. Loss of coating due to inadequate erosion protection

7.3.3.1 Strength of Paint Film

Paint films require hardness, flexibility, brittleness resistance, mar resistance, and sag resistance. Paint coatings are formulated to provide a balance among these mechanical properties. The mechanical strength of a paint film is described by the words "hardness" and "plasticity," which correspond to the modulus of elasticity and to the elongation at break obtained from the stress-strain curve of a paint film. Typical paint films have tensile properties as shown in Table 7.7. The mechanical properties of paint coatings vary, depending on the type of pigment, baking temperatures, and aging times. As baking temperatures rise, the curing of paint films is promoted and elongation is reduced. Tensile strength is improved by curing and the elongation at breaks is reduced with increased drying time.

TABLE 7.7

Tensile Properties of Typical Paint Films

Paints	Tensile Strength (g/mm)	Elongation at Break (%)
Linseed oil	14–492	2–40
Alkyd resin varnish (16% PA)	141–1206	30–50
Amino-alkyd resin varnish (AW = 7/3)	2180–2602	—
NC lacquer	844–2622	2–8
Methyl-n-butyl-meta-acrylic resin	1758–2532	19–49

Structural defects in a paint film cause failures that are determined by environmental conditions such as thermal reaction, oxidation, photooxidation, and photochemical reaction. An important factor in controlling the physical properties of a paint film is the glass transition temperature, T_g . In the temperature range higher than T_g , the motion of the resin molecules becomes active, such that the hardness, plasticity, and permeability of water and oxygen vary greatly. Table 7.8 lists the glass transition temperatures of organic films.

Deterioration of paint films is promoted by photolysis, photooxidation, or photothermal reaction as a result of exposure to natural light. As explained previously, UV light ($\lambda = 40\text{--}400\text{ nm}$) decomposes some polymer structures. Polymer films such as vinyl chloride resins are gradually decomposed by absorbing the energy of UV light. The T_g of a polymer is of critical importance in the photolysis process. Radicals formed by photolysis are trapped

TABLE 7.8

Glass Transition Temperature of Organic Films

Organic Film	Glass Transition Temperature, T_g (°C)
Phthalic acid resin	50
Acrylic lacquer	80–90
Chlorinated rubber	50
Bake-type melamine resin	90–100
Anionic resin	80
Cationic resin	120
Epoxy resin	80
Tar epoxy resin	70
Polyurethane resin	40–60
Unsaturated polyester	80–90
Acrylic powder paint	100

in the matrix but they diffuse and react at temperatures higher than T_g . The principal chains of polymers with ketone groups form radicals:



The resultant radicals accelerate the degradation of the polymer and, in some cases, HCl (from polyvinyl chloride) or CH_4 is produced.

7.3.3.2 Cohesive Failure

In chemical terms, there is a similarity between paints on one side and adhesives or glue on the other (see Figure 7.1). Both materials appear in the form of organic coatings. A paint coating is, in essence, a polymer consisting of more or less crosslinked macromolecules and certain amounts of pigments and fillers. Metals, woods, plastics, paper, leather, concrete, or masonry, to name only the most important materials, form a substrate for the coating.

It is important to keep in mind that these substrate materials can exhibit a rigidity higher than that of the coating. Under these conditions, fracture will occur within the coating if the system experiences an external force of sufficient intensity. Cohesive failure will result if the adhesion at the interface exceeds the cohesion of the paint layer. Otherwise, adhesive failure is the result, indicating a definite separation between the coating and the substrate.

Both types of failures are encountered in practice. The existence of cohesive failure indicates the attainment of an optimal adhesion strength.

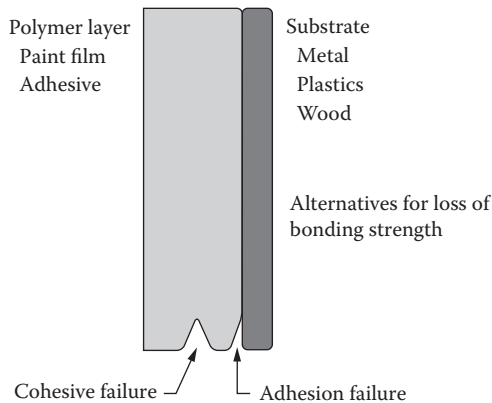

FIGURE 7.1

Bonding situation at the interface of polymer layer and substrate.

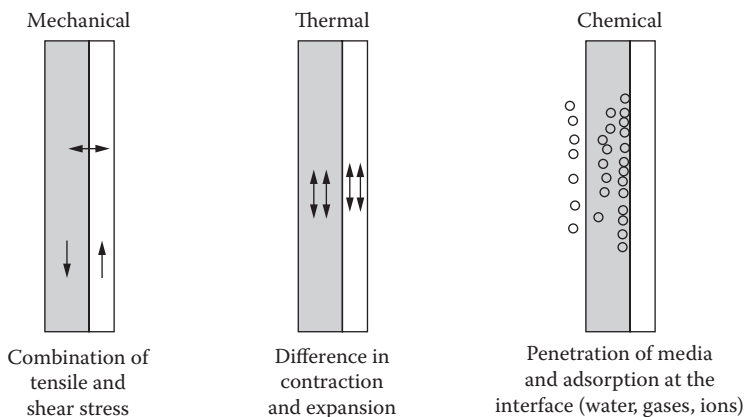

FIGURE 7.2
(a) Mechanical, (b) thermal, and (c) chemical bond failure.

7.3.3.3 Stress and Chemical Failures

Several external factors can induce stress between the bond and the coating, causing eventual failure. These factors can act individually or in combination (see Figure 7.2).

First may be regular mechanical stress, which not only affects the bulk of the materials, but also the bond strength at the interface. The stress may be tensile stress that acts perpendicular to the surface, or shear stress that acts along the plane of contact.

Because coatings can undergo changes in temperature, and sometimes rapidly, any difference in the coefficient of expansion can cause stress concentrations at the interface. These stresses may be of such magnitude that the paint film detaches from the substrate. Temperature effects tend to be less obvious than mechanical and chemical factors.

In certain environments, the presence of a chemical can penetrate the coating and become absorbed at the interface, causing loss of adhesion.

Any testing done to measure the adhesion of a coating should take into account these effects so that the method employed will reproduce the end-use conditions.

7.4 Types of Corrosion under Organic Coatings

For corrosion to take place on a metal surface *under* a coating, it is necessary to establish an electrochemical double layer. For this to take place, it is necessary to break the adhesion between the substrate and coating. This permits a

separate thin water layer to form at the interface from water that has permeated the coating. As mentioned previously, all organic coatings are permeable to water to some extent.

The permeability of a coating is often given in terms of the permeation coefficient P . This is defined as the product of the solubility in water in the coating (S , kg/cm³), the diffusion coefficient of water in the coating (D , m²/s), and the specific mass of water (p , kg/m²). Therefore, different coatings can have the same permeation coefficient, although the solubility and diffusion coefficient, both being material constants, are very different. This limits the usefulness of the permeation coefficient.

Water permeation takes place under the influence of several driving forces, including:

1. A concentration gradient during immersion or during exposure to a humid atmosphere resulting in true diffusion through the polymer
2. Capillary forces in the coating resulting from poor curing, improper solvent evaporation, bad interaction between binder and additives, or entrapment of air during application
3. Osmosis due to impurities or corrosion products at the interface between the metal and the coating

Given sufficient time, a coating system that is exposed to an aqueous solution or a humid atmosphere will be permeated. Water molecules will eventually reach the coating/substrate interface. Saturation will occur after a relatively short period of time (on the order of 1 h), depending on the values of D and S and the thickness of the layer. Typical values for D and S are 10^{-13} m²/s and 3%, respectively. Periods of saturation under atmospheric exposure are determined by the actual cyclic behavior of the temperature and humidity. In any case, situations will develop in which water molecules reach the coating/metal surface interface where they can interfere with the bonding between the coating and the substrate, eventually resulting in loss of adhesion and corrosion initiation, providing that a cathodic reaction can take place. A constant supply of water or oxygen is required for the corrosion reaction to proceed. Water permeation can also result in the buildup of high osmotic pressures, resulting in blistering and delamination.

7.4.1 Wet Adhesion

Adhesion between the coating and the substrate can be affected when water molecules have reached the coating/substrate interface. The degree to which permeated water can change the adhesion properties of a coated system is referred to as wet adhesion. Two different theories have been proposed for the mechanism for the loss of adhesion due to water:

1. *Chemical disbondment* resulting from the chemical interaction of water molecules with covalent hydrogen, or polar bonds between polymer and metal (oxide)
2. *Mechanical or hydrodynamic disbondment* as a result of forces caused by accumulation of water and osmotic pressure

For chemical disbondment to take place, it is not necessary that there be any sites of poorly bonded coating. This is not the case for mechanical disbonding, where water is supposed to condense at existing sites of bad adhesion. The water volume at the interface may subsequently increase due to osmosis. As the water volume increases under the coating, hydrodynamic stresses develop. These stresses eventually result in an increase in the non-adherent area.

7.4.2 Osmosis

Osmotic pressure can develop from one or more of the following:

1. Pressure of soluble salts as contaminants at the original metal surface
2. Inhomogeneities in the metal surface such as precipitates, grain boundaries, or particles from blasting pretreatment
3. Surface roughness due to abrasion

Once corrosion has started at the interface, the corrosion products produced can be responsible for the increase in osmotic pressure.

7.4.3 Blistering

Various phenomena can be responsible for the formation of blisters and the start of underfilm corrosion. These include the presence of voids, wet adhesion problems, swelling of the coating during water uptake, gas inclusions, impurity ions in the coating, poor general adhesion properties, and defects in the coating.

When a coating is exposed to an aqueous solution, water vapor molecules and some oxygen diffuse into the film and end up at the substrate interface. Eventually, a thin film of water may develop at the sites of poor adhesion or at the site where wet adhesion problems arise. A corrosion reaction can start with the presence of an aqueous electrolyte with an electrochemical double layer, oxygen, and the metal. This reaction will cause the formation of macroscopic blisters. Depending on the specific materials and circumstances, the blisters may grow out because of the hydrodynamic pressure in combination with one of the chemical propagation mechanisms such as cathodic delamination and anodic undermining.

7.4.4 Cathodic Delamination

When cathodic protection is applied to a coated metal, loss of adhesion between the substrate and the paint film, adjacent to defects, often takes place. This loss of adhesion is known as *cathodic delamination*. Such delamination can also occur in the absence of applied potential. Separate anodic and cathodic reaction sites under the coating result in a driving force, as during external polarization. The propagation of a blister due to cathodic delamination under an undamaged coating on a steel substrate is illustrated in Figure 7.3. Under an intact coating, corrosion may be initiated locally at sites of poor adhesion.

A similar situation develops in the case of corrosion under a defective coating. When there is a small defect in the coating, part of the substrate is directly exposed to the corrosive environment. Corrosion products are formed immediately that block the damaged site from oxygen. The defect in

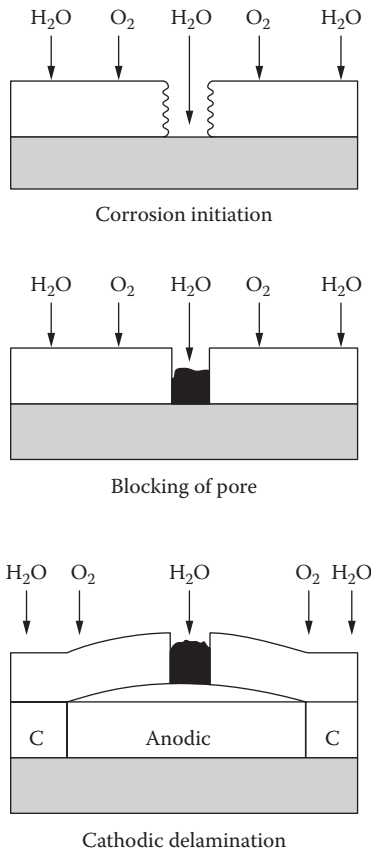

FIGURE 7.3

Blister initiation and propagation under a defective coating (cathodic delamination).

the coating is sealed by corrosion products, after which corrosion propagation takes place according to the same mechanism as for the initially damaged coating. See Figure 7.3 for the sequence of events.

7.4.5 Anodic Undermining

Anodic undermining results from the loss of adhesion caused by anodic dissolution of the substrate metal or its oxide. In contrast to cathodic delamination, the metal is anodic at the blister edges. Coating defects may cause anodic undermining, but in most cases it is associated with a corrosion-sensitive site under the coating, such as a particle from a cleaning or a blasting procedure, or a site on the metal surface with potentially increased corrosion activity (e.g., scratches). These sites become active once the corrodent has penetrated to the metal surface. The initial corrosion rate is low. However, an osmotic pressure is caused by the soluble corrosion products that stimulate blister growth. Once formed, the blisters will grow due to a type of anodic corrosion at the edge of the blister.

Coated aluminum is very sensitive to anodic undermining, while steel is more sensitive to cathodic delamination.

7.4.6 Filiform Corrosion

Metals with semipermeable coatings or films may undergo a type of corrosion resulting in numerous thread-like filaments of corrosion beneath the coatings or films. Conditions that promote this type of corrosion include:

1. High relative humidity (60 to 95% at room temperature)
2. Coating is permeable to water
3. Contaminants (salts, etc.) are present on or in the coating, or at the coating/substrate interface
4. Coating has defects (e.g., mechanical damage, pores, insufficient coverage of localized areas, air bubbles)

Filiform corrosion under organic coatings is common on steel, aluminum, magnesium, and zinc (galvanized steel). It has also been observed under electroplated silver plate, gold plate, and phosphate coatings.

This form of corrosion is more prevalent under organic coatings on aluminum than on other metallic surfaces, it being a special form of anodic undermining. A differential aeration cell is the driving force. The filaments have considerable length but little width and depth, and consist of two parts: a head and a tail. The primary corrosion reactions, and subsequently the delamination process of the paint film, take place in the active head, while the tail is filled with the resulting corrosion products. As the head of the filiform moves, the tail grows in length.

7.4.7 Early Rusting

When a latex paint is applied to a cold steel substrate under high moisture conditions, a measles-like appearance may develop immediately when the coating is touch-dry. This corrosion takes place when the following conditions exist:

1. The air humidity is high.
2. The substrate temperature is low.
3. A thin (up to 40 μm) latex coating is applied.

7.4.8 Flash Rusting

Flash rusting refers to the appearance of brown stains on a blasted steel surface immediately after applying a water-based primer. Contaminants remaining on the metal surface after blast cleaning are responsible for this corrosion. The grit on the surface provides crevices or local galvanic cells that activate the corrosion process as soon as the surface is wetted by the water-based primer.

7.5 Stages of Corrosion

To prevent excessive corrosion, good inspection procedures and preventative maintenance practices are required. Proper design considerations are also necessary, as well as selection of the proper coating system. Regular inspections of coatings should be conducted. Because corrosion of substrates under coatings takes place in stages, early detection will permit correction of the problem, thereby preventing ultimate failure.

7.5.1 First Stages of Corrosion

The first stages of corrosion are indicated by rust spotting or the appearance of a few small blisters. Rust spotting is the very earliest stage of corrosion and in many cases is left unattended. Standards have been established for evaluating the degree of rust spotting and these can be found in ASTM 610–68 or Steel Structures Painting Council Vis-2. One rust spot in 1 square foot may provide a 9+ rating but three or four rust spots drop the rating to 8. If the rust spots go unattended, a mechanism for further corrosion is provided.

Blistering is another form of early corrosion. Frequently, blistering occurs without any external evidence of rusting or corrosion. The mechanism of blistering is attributed to osmotic attack or a dilution of the coating film at the interface with the steel under the influence of moisture.

Water and gases pass through the film and dissolve some ionic material from either the film or the substrate, causing an osmotic pressure greater than that of the external face of the coating. This produces a solution concentration gradient, with water building up at these sites until the film eventually blisters. Visual blistering standards are found in ASTM D-714-56.

Electrochemical reactions also assist in the formation of these blisters. Water diffuses through a coating also by an electro-osmotic gradient. Once corrosion starts, moisture is pulled through the coating by an electrical potential gradient between the corroding areas and the protected areas that are in electrical contact. Therefore, osmosis starts the blistering, and once corrosion begins, electro-endosmotic reactions accelerate the corrosion process. The addition of heat and acidic chemicals increases the rate of breakdown. Temperatures of 150 to 200°F (66 to 93°C) accelerate the chemical reaction. Under these conditions, steel will literally dissolve in a chemical environment. Moisture is always present and afterward condenses on the surface behind the blister. This condensation offers a solute for gaseous permeants to dissolve. When the environment is acidic, the pH of the water behind the blister can be as low as 1.0 or 2.0, thus subjecting the steel to severe attack.

7.5.2 Second Stage of Corrosion

After observing the initial one or two rust spots, or after having found a few blisters, a general rusting in the form of multiple rust develops. This rusting is predominantly Fe_2O_3 , a red rust. In atmospheres lacking oxygen, such as in sulfur dioxide scrubbers, a black FeO develops. Once the unit has been shut down and more oxygen becomes available, the FeO will eventually convert to Fe_2O_3 .

7.5.3 Third Stage of Corrosion

This advanced stage of corrosion is the total disbondment of the coating from the substrate, exposing the substrate directly to the corrodents. Corrosion can occur at an uninhibited rate because the coating is no longer protecting the steel.

7.5.4 Fourth Stage of Corrosion

Attack of the metal substrate after removal of the coating is not usually of a uniform nature but rather that of a localized attack, resulting in pitting.

7.5.5 Fifth Stage of Corrosion

Deep pits formed in the substrate during the fourth stage of attack can eventually permeate completely to cause holes. Within the corrosion cell, pitting

has occurred to such a degree that undercutting, flaking, and delamination of the substrate take place. As the small hole develops, the electrolyte has access to the reverse side and corrosion now takes place on both sides of the substrate.

7.5.6 Final Stage of Corrosion

Corrosion is now taking place at its most rapid and aggressive rate. Large gaping holes are formed, causing severe structural damage.

7.6 Surface Preparation

Surface preparation, which includes cleaning and pretreatment, is the most important step in any coating operation. For coatings to adhere, surfaces must be free from oily soils, corrosion products, and loose particles. While new wood surfaces may be coated without cleaning, old wood surfaces must be cleaned to remove any loose, flaky coatings and oily soils. Chemicals are used to remove mold release from plastics. Metals are cleaned using solvents, or aqueous chemicals, or by media blasting, sanding, and brushing. The choice of cleaning method depends on the substrate and the size and shape of the object.

To remove coating adhesion, pretreatments are applied after cleaning. In the case of metals, these pretreatments also provide some corrosion resistance. Wood surfaces may require the priming of knots and the filling of nail holes. Acids are used to remove loosely adhering contaminants and to passivate cementitious and masonry surfaces. Some plastic surfaces may be painted after cleaning to remove mold release, but others may require additional pretreatments to ensure coating adhesion.

A detailed discussion of the cleaning and pretreatment of various substances follows.

7.6.1 Metal Substrate Preparation

Initially, a “pre-surface-preparation inspection” should be made. This inspection is to determine if additional work should be done by other crafts before the start of surface preparation for painting. Such other work might include grinding and rounding of edges and welds; removal of weld spatter, heavy deposits of oil, grease, cement spatter, or other contaminants; moving equipment out of the work area; masking or otherwise protecting equipment or items not to be painted in the work area; and other such preliminary activities. Only after this is done can the painters begin to work effectively.

Oily soils must be removed before any other surface preparation is undertaken. Otherwise these soils might spread over the surface. These soils can also contaminate abrasive cleaning media and tools. Oily soils can be removed faster using liquid cleaners that impinge on the surface or in agitation immersion baths. It is often necessary to heat liquid cleaners to facilitate soil removal.

Coating application, in the most basic terms, is the preparation of the surface to receive the paint and the application of the paint in the proper manner to the specified thickness. The surface preparation specified is predicated by the coating system to be applied. It is usually a good idea to specify a "standard" surface preparation method. The most common standard methods are those defined by the Steel Structures Painting Council (SSPC). Table 7.9 summarizes the SSPC surface preparation methods. These standards, and others prepared by the National Association of Corrosion Engineers, the Society of Naval Architects and Marine Engineers, various highway departments, and private corporations, are almost always final appearance standards. These standards give the desired end product but do not describe in detail the

TABLE 7.9

Summary of Surface Preparation Specifications

SSPC Specification	Description
SP 1 Solvent cleaning	Removal of oil, grease, dirt soil, salts, and contaminants by cleaning with solvent, vapor, alkali, steam or emulsion
SP 2 Hand-tool cleaning	Removal of loose rust, mill scale, and paint to the degree specified by hand chipping, scraping, and wire brushing
SP 3 Power-tool cleaning	Removal of loose rust, mill scale, and paint to the degree specified by power tool chipping, descaling sanding, wire brushing, and grinding
SP 5 White-metal blast cleaning	Removal of all visible rust, mill scale paint, and foreign matter by blast cleaning by wheel or nozzle (wet or dry), using sand, grit, or shot (for very corrosive atmospheres where high cost of cleaning is warranted)
SP 6 Commercial blast cleaning	Blast cleaning until at least two thirds of the surface area is free of all visible residues (for rather severe conditions of exposure)
SP 7 Brush-off blast cleaning	Blast cleaning of all except tightly adhering residues of mill scale, rust, and coatings, exposing numerous evenly distributed flecks of underlying metal
SP 8 Pickling	Complete removal of rust and mill scale by acid pickling, duplex pickling, or electrolytic pickling
SP 10 Near-white blast cleaning	Blast cleaning to near-white cleanliness until at least 95% of the surface area is free of all visible residues (for high humidity, chemical atmosphere, marine, or other corrosive environments)

means to achieve this end. It is important, therefore, that the painter or the person doing the surface preparation be knowledgeable. It is important that the various pieces of equipment be sized properly; that air and abrasives (if used) be cleaned, graded, and free of moisture, oil, and other contaminants; and that ambient conditions be controlled, or at least closely monitored.

Surface preparation techniques have changed drastically. Silica sand has been banned in all Western countries except the United States and Canada (although there is a strong movement to ban it in these countries as well) as a blast-cleaning abrasive. To prevent environmental damage caused by the leaching into water supplies of lead, chromate, and other toxic paint pigments removed during the course of blast cleaning, many localities require the safe containment and disposal of spent blast-cleaning abrasives. Although a paint layer over a properly cleaned surface still acts as a barrier against a corrosive environment, in many cases the components that form the barrier have changed considerably.

In some environments, certain surface preparation and coating application techniques are not permissible. For example, many companies do not permit open blast cleaning where there is a prevalence of electric motors or hydraulic equipment. Refineries, as a general rule, do not permit open blast cleaning — or for that matter, any method of surface preparation that might result in the possibility of a spark, static electricity buildup, or an explosion hazard. During the course of construction or erection, many areas requiring protection are enclosed or covered, or so positioned that access is difficult or impossible. Consideration must be given to painting these structures prior to installation.

Some methods of coating must be done at a specialized facility because the equipment used is not readily transportable to field sites. Typical methods include most chemical cleaning, including pickling and acid etching; automatic rotary wheel blasting; and automatic spraying, electrostatic, or high-speed roller coating application.

7.6.1.1 Abrasive Cleaning

Abrasive cleaning is undertaken after oily soils have been removed. Rust and corrosion are removed by media blast, hand or power sanding, and hand or power blasting. Media blasting is accomplished by propelling, under pressure, materials such as sand, metallic shot, nut shells, plastic pellets, or dry ice crystals so that they impinge on the surfaces to be cleaned. High-pressure water jet cleaning is similar to media blasting.

7.6.1.2 Detergent Cleaning

Aqueous solutions of detergents are used to remove oily soils. They are applied to metals by immersion or spray. After cleaning, the surfaces are rinsed with clean water to remove the detergent. Detergents will not remove rust and corrosion.

7.6.1.3 Alkaline Cleaning

Aqueous solutions of alkaline phosphates, borates, and hydroxides are used to remove oily soils in much the same way as detergents. After cleaning, they are washed away with clear water.

7.6.1.4 Emulsion Cleaning

Aqueous emulsions of organic solvents such as mineral spirits and kerosene are used to remove heavy oily soils and greases. After dissolving the oily soils, the emulsions are flushed away with hot water. Any remaining oily residue is removed using clean solvent, detergent, or alkaline cleaners.

7.6.1.5 Solvent Cleaning

Organic solvents are effective in removing oily soils. Hand wiping, spraying, or immersion methods may be employed. The solvents and wipers will become contaminated with these soils and therefore must be changed frequently to prevent oily residues from remaining on the surface. Because of the hazardous nature of these solvents, safe handling practices must be employed.

7.6.1.6 Vapor Degreasing

Boiling solvent condenses on the cool surface to be cleaned and flushes away oily soils but does not remove particulates. Although once very popular, the use of this process is declining. The process employs chlorinated solvents that are under regulatory scrutiny by governmental agencies.

7.6.1.7 Steam Cleaning

The application of detergents and alkaline cleaners using steam cleaners is an effective degreasing method. Heavy greases and waxes are dissolved and flushed away by the impingement of steam and the action of the chemicals. Hot-water spray cleaning using chemicals is almost as effective as steam cleaning.

7.6.2 Metal Surface Pretreatment

Because abrasive cleaning removes corrosion, it is also considered a pretreatment. The impingement of blasting media and the action of brushes and abrasive pads roughen the substrate and thereby improve adhesion. The other cleaning methods that remove oily soils do not generally remove rust and corrosion from the substrates.

Other pretreatments use aqueous chemical solutions that are applied by immersion or spray techniques. These chemicals prepare the substrate surface to accept the coating and to improve adhesion. Different metals are treated in different ways.

7.6.2.1 Aluminum

After the aluminum substrate has been treated to remove oily soils and corrosion products, it is pretreated using chromate conversion coating and anodizing. A phosphoric-acid-activated vinyl wash primer, which is also a pretreatment, must be applied directly to the metal and not over other pretreatments.

7.6.2.2 Copper

After cleaning by solvents and chemicals, the surface is abraded to remove corrosion; bright dipping in acids will also remove corrosion. Chromates and vinyl wash primers are used to pretreat the cleaned surfaces.

7.6.2.3 Galvanized Steel

To prevent white corrosion, the mill applies oil and wax to the galvanized steel surface, which must be removed. After cleaning, chromates and phosphates are used to pretreat the surface. If no other pretreatment has been utilized, a vinyl wash primer can be used.

7.6.2.4 Steel

Phosphate pretreatment is usually applied to steel to provide corrosion resistance after cleaning to remove rust and oily soils. Chromates and wash primers are possible alternative pretreatments.

7.6.2.5 Stainless Steel

Under normal circumstances, stainless steel is not usually coated because of its corrosion resistance. If it is to be coated, oily soils must be removed and the surface abraded to produce roughness. Wash primers will improve adhesion.

7.6.2.6 Titanium

Cleaned titanium is pretreated the same as stainless steel (see above).

7.6.2.7 Zinc and Cadmium

Zinc and cadmium substrates are treated the same as galvanized steel (see above).

7.6.3 Plastic Substrate Preparation

As with metallic substrates, surface preparation has the greatest impact on film adhesion. Film adhesion to a plastic is primarily a surface phenomenon and requires intimate contact between the substrate surface and the coating. Without appropriate conditioning and cleaning, intimate contact with the plastic surface is not possible.

Plastic surfaces present a number of unique problems. Many plastics, such as polyethylene and fluorinated polymers, have a low surface energy, which means that few materials will readily adhere to the surface. Plastic materials are often formulations of one or more polymer types, or have various amounts of inorganic fillers. In addition, the coefficient of thermal expansion is usually quite high for plastic compounds and can vary widely, depending on polymer blend, filler content, and filler type. The flexibility of plastic materials puts more stress on the coating, and serious problems can develop if film adhesion is low as a result of poor surface preparation.

Surface preparation, depending on the polymer, is required to:

1. Remove process oils, dirt, grime, waxes, mold release agents, and poorly retained plasticizers.
2. Match the finish on the plastic to the coating viscosity for improved film adhesion.
3. Convert the surface of the plastic to provide an interface that is more like, or compatible with, the chemical structure of the coating.
4. Promote oxide formation to produce a higher level of surface activity.
5. Control absorbed water, which can interfere with adhesion.

There are as many procedures for cleaning and preparing plastic surfaces as there are polymer types. Most plastic types have recommended procedures for achieving the best finish for coating. Many polymers can be blended together to achieve specific properties. Fillers and plasticizers are also included in the resin matrix to yield certain characteristics. The same preparation procedure may not be suitable in each of these cases.

Advice as to the appropriate surface preparation procedure to use should be available from the manufacturer of both the plastic and the coating. However, because of the possible unique needs of the user, even the manufacturer may not have a definite answer. Experimentation may be required to identify the most suitable technique for a specific application.

The procedures described concentrate on the technique and not the plastic. In some cases, certain techniques are recommended for specific polymers.

It must be noted that many of the surface preparation processes involve the use of hazardous, corrosive, toxic, flammable, and/or poisonous chemicals. It is essential that appropriate control procedures and safe handling methods be employed to minimize risk in the work environment.

7.6.3.1 Solvent Cleaning

The easiest and most common procedure used to remove surface contamination is by means of solvent action, which removes surface contamination by dissolving the unwanted substance. Organic solvents and water are used for this purpose.

Organic solvents may be flammable or nonflammable. The most commonly used are acetone, methyl ethyl ketone, toluol, 1,1,1-trichloroethane, naphtha, and, on occasion, Freon (either by itself or blended with another solvent).

Although water is inexpensive and plentiful, it often has trace levels of impurities that can contaminate surfaces. Consequently, distilled or deionized water is recommended. Water is frequently used as a rinse for other surface preparation procedures.

These solvents can be applied in one of several methods, including simple wiping with a dampened cloth, immersion in a swirling bath with heat applied to speed the solvent action, and spray cleaning. Spray cleaning has the advantage of flushing off the contamination with the force of the spray. Vapor degreasing is also employed. In this case, the plastic part is suspended over a boiling tank of solvent. As the vapors condense on the part, the constant flow over the surface washes it clean. High-frequency vibration from sonic waves in a solvent bath is also used to remove contaminants.

Before use, the compatibility of the solvent with the plastic must be verified. Regardless of the process used, frequent changing or filtering of the solvent is recommended to prevent buildup and recontamination. When using heat to dry the parts after washing, care must be taken because heat can very easily distort plastics.

7.6.3.2 Detergent Cleaning

Emulsification of oils, greases, and some mold releases is easily achieved in either hot- or cold-water solutions of detergents or soaps. Recommended materials include Ivory soap, Ajax cleanser, Borax (sodium borate), and trisodium phosphate (TSP) in various cleaning operations.

Unless the plastic is water sensitive, an immersion wash is effective. Scouring with a medium-to-stiff brush works quite well for dislodging many contaminants.

Because soap can act as a contaminant, it is essential that a thorough rinse be applied using clean water. Thorough drying at elevated temperatures is

recommended. Detergent cleaning is often used as a preliminary step to mechanical treatments.

7.6.3.3 Mechanical Treatments

A solvent or detergent cleaning process must precede a mechanical treatment to prevent scrubbing surface contaminants into the roughened surface. Physical scrubbing of plastic surfaces removes oxides and contaminated layers.

A commonly used procedure is either wet or dry sanding, using a grit of 40 to 400. The grit size depends on the amount of surface to be removed and the surface finish desired. Softer plastics are more susceptible to damage.

Grit blasting, either wet or dry, and wire brushing are appropriate techniques to use on parts that have complex configurations. Grit size and type can be varied to obtain the proper finish.

Regardless of the method employed, the roughened surface should be vacuumed or air-blasted to remove residual dust or grit. It is recommended that this be followed by a solvent wipe or water rinse, followed by elevated drying.

7.6.3.4 Chemical Treatment

A chemical etch of the plastic to be coated is, in general, the most effective surface preparation technique. Both physical and chemical characteristics of the plastic can be modified to improve wet-out and film adhesion. To reduce surface contamination and to obtain optimum interaction between the chemical and the substrate, one or more of the cleaning operations must be employed prior to the chemical treatment.

Chemical treatment involves the surface being washed or immersed in a bath containing an acid, base, oxidizing agent, chlorinating agent, or other highly active chemical. Regardless of the agent being used, it is necessary to control the parts by weight of the active ingredient, the temperature of the solution, and the elapsed time of immersion. Some procedures have a wide range of ingredient ratios, while others are quite specific. The temperature of the solution is inversely proportional to the time of immersion — the higher the temperature, the shorter the immersion time. It is important that solution strength be monitored and renewed as required.

All chemical etch techniques require a water rinse and elevated temperature drying.

- *Sulfuric acid etch.* The sulfuric acid-dichromate etch is recommended for use on acrylonitrile-butyladiene-styrene (ABS), acetal, melamine, or urea, polyolefins, polyphenylene oxide, polystyrene, polysulfone, and styrene-acrylonitrile (SAS). A different ingredient ratio, immersion temperature, and immersion time is recommended for each plastic. Table 7.10 shows the parameters of the sulfuric acid-dichromate etch.

TABLE 7.10

Parameters of Sulfuric Acid-Dichromate Etch Bath

Ingredient	Parts (by weight)	Range
Potassium or sodium dichromate	5	0.5–10.0
Concentrated sulfuric acid	85	65.0–96.5
Water	10	0–27.5
Time	10 sec–90 min	
Temperature	Room temperature to 160°F (71°C)	

- *Sodium etch.* Highly reactive chemicals must be used to etch difficult surfaces to coat as the various fluoroplastics and some thermoplastic polyesters. A typical solution used contains 2 to 4 parts metallic sodium dispersed in a mixture of 10 to 12 parts naphthalene and 85 to 87 parts tetrahydrofuran.

Immersion time is 15 min at ambient temperatures, followed by a thorough rinsing with a kerosene solvent and rinsing with water.

- *Sodium hydroxide etch.* Thermoplastic polyesters, polyamides, and polysulfone can be effectively treated using a mixture of 20 parts by weight of sodium hydroxide and 80 parts by weight of water. The plastic is immersed in the 175 to 200°F (24 to 93°C) bath for a period of 2 to 10 min.
- *Satinizing.* DuPont developed this process for the treatment of its homo-polymer-grade acetal (U.S. Patent 3,235,426). A heated solution of dioxane, *para*-toluene sulfonic acid, perchlorethylene, and a thickening agent is prepared, into which parts are dipped. After the dip cycle, parts are heat-treated, rinsed, and dried in accordance with a prescribed procedure.
- *Phenol etch.* An 80% solution of phenol is used to etch nylon. The solution is brushed onto the surface at room temperature and then allowed to dry for approximately 20 min at 150°F (66°C).
- *Sodium hypochlorite etch.* The newer thermoplastic rubbers and several of the thermoplastic polymers can be chlorinated on the surface by applying the following solution (parts by weight):

15% sodium hypochlorite	2–3 parts by weight
Concentrated hydrochloric acid	1–2 parts by weight
Water	95–97 parts by weight

7.6.3.5 Other Treatments

Procedures have been developed specifically for plastic processing to overcome the low surface activity of many of these materials. Prior removal of surface contamination by solvent or detergent cleaning is necessary in most cases to achieve optimum results.

- *Primers.* The application of a primer coating is used to develop better adhesion of the final coating to the plastic substrate. A variety of chemical types can be used as primers, including urethane polymers, silicones, nitriles, phenolics, vinyls, or isocyanates. The primer is applied to the surface as soon as possible after other surface preparation procedures have been completed in order to protect the surface from recontamination.
- *Flame treatment.* The surface of many plastics, such as acetals, polyolefins, fluoropolymers, and polycarbonates, are oxidized by the impingement of a flame. The oxidation provides a higher level of surface energy and better film adhesion. This process is particularly effective on complex shapes and molded parts. Superheated air at 1000°F (538°C) is just as effective.
- *Exposure to UV radiation.* An ionized or highly polar surface results after exposure to high-intensity UV radiation.
- *Drying.* Over-drying can be effective on plastic formulations that absorb atmospheric moisture.
- *Plasma treatment.* Plasma treatments are effective for most plastics. Parts are exposed to gases such as neon, helium, oxygen, and moisture vapor, which are ionized by radio-frequency or microwave discharge. Although very effective in improving surface conditions that promote better film adhesion, this process is limited to smaller components and parts because of equipment size.
- *Corona discharge.* Surface tension can be improved by passing film or thin-gauge plastics between two electrodes. This treatment is suitable for high-speed operations.

7.7 Application of Coatings

Over the years there have been many changes in the formulation of coatings that have affected the methods by which they are applied to a substrate. Several of these changes have resulted from governmental regulations.

The Occupational Safety and Health Administration (OSHA) and the Toxic Substances Control Act (TSCA) regulate the environment in the workplace

and limit workers' contact with hazardous materials. OSHA and the TSCA make it necessary to use alternate coating materials and to modify application procedures in order to comply.

In the late 1940s, smoke control laws were enacted to reduce airborne particulates that led to air pollution. During this period, a condition known as "photochemical fog" developed as a result of increased automobile usage and industrial expansion. The fog was created by the reaction of chemicals in the atmosphere to sunlight. Los Angeles County officials, recognizing that automobile exhaust and VOC (volatile organic compound) emissions were major sources of smog, enacted an air pollution regulation called Rule 66. Under Rule 66, specific solvents that produce photochemical smog were banned from use. At the same time, they published a list of acceptable solvents that could be used in coatings. The EPA conducted additional studies that indicated that these so-called "acceptable" solvents, given enough time, would also produce photochemical smog in the atmosphere.

The EPA established national air quality standards (in its Clean Air Act of 1970 and its 1990 amendments) that regulate the amounts of solvents that can be emitted. Many local standards are more stringent than the national standard. Consequently, specific coatings may not comply with regulations in all areas. Waterborne, powder, high-solids, electropheric, and radiation-cured coatings will comply in all areas.

In addition, certain types of paints, primarily those containing lead and asbestos, have been outlawed by federal and local jurisdictions. Potentially harmful pigments or other constituents are causing the restriction of other paints containing these ingredients.

It is important that, during the application of any coating, adequate ventilation for the removal of solvents be provided, as well as suitable and safe access to the work being painted.

7.7.1 Application Methods

The method of application of a corrosion-resistant paint will depend on the:

1. Purpose for which coated product will be used
2. Environment to which the coating will be exposed
3. Type of paint
4. Shape and size of the object to be painted
5. Period of application process
6. Cost

Application methods vary from the traditional paint brush or roller to various spray techniques, powder coating, and electrodeposition. Exact procedures will depend on the specific coating used and the object to be coated.

7.7.1.1 Brushing

Brushing is an effective, relatively simple method of paint application, particularly with primers, because of the ability to work the paint into pores and surface irregularities. Because brushing is slow, it is used primarily for smaller jobs, surfaces with complex configurations (edges, corners, cuts, etc.), or where overspray might cause a serious problem.

Brushing was once the main coating method but, at the present, spray coating is more widely used. Brush coating has the following advantages:

1. Applicators are simple and inexpensive.
2. Complicated forms and shapes can be coated.
3. Thick films are obtained with one coat.
4. Particularly useful in applying an anti-rust coating.

The disadvantage of brushing results from the nonuniformity of coating layers, especially coating layers of rapidly drying paints.

7.7.1.2 Rolling

The advantage of using rollers is found when used on large, flat areas that do not require the smoothness or uniformity that can be obtained by spraying. They are also used in interior areas, where overspray presents a cleaning and masking problem. Because of the difficulty of penetrating pores, cracks, and other surface irregularities, the use of a brush is preferred when applying primers. When using a roller, air mixes with the paint and leaves points where moisture can penetrate the cured film. Rolling is best when used to apply a topcoat over a primer that has been applied by some other method.

7.7.1.3 Roller Coating

Roller coating is a process to coat coils and sheets by passing them through two preset rollers. The quantity of paint consumed is reduced by approximately 50% of that used with other coating methods. The thickness of the film is controlled by adjusting the rollers. One-side or both-side coatings are possible.

7.7.1.4 Spray Painting

A more uniform and smoother surface can be achieved with spray painting than with brushing or rolling because the latter methods tend to leave brush or stipple marks with irregular thickness. The most common methods of spray painting are conventional and airless.

The conventional spray method relies on air for paint atomization. Jets of compressed air, introduced into the stream of paint at the nozzle, break the stream into tiny droplets that are carried to the surface by the air current. Paint losses from bounce-back or overspray can be high because large amounts of air are mixed with the paint during application. Such losses have been estimated to be as much as 30 to 50%.

Some of the disadvantages of conventional air spray applications include:

1. It is slower than airless application.
2. More overspray results than from other methods.
3. It is difficult to coat corners, crevices, etc., because of blowback.

An airless spray system consists of:

1. A plunger pump that supplies high pressure to the paint
2. An airless spraygun
3. A high-pressure-resistant hose

High-viscosity paints are warmed before spraying. This technique has the following advantages over an air spray system:

1. The sticking rate of paint is increased by 24 to 40%.
2. A thicker film can be applied.
3. The running of paint on the substrate is reduced.
4. Because there is only one hose, it is easier for the operator to use.
5. Higher viscosity paints can be applied.
6. Clean-up is easier.

Because the airless spray process is more efficient than brushing, it is suitable for coating steel structures and bridge girders in the factory. However, paint loss using the airless spray process is 30 to 40% greater than that of brushing. The disadvantages of the airless spray system include:

1. Reliance on dangerous high pressure
2. Fan pattern is not adjustable
3. Additional working parts that can cause difficulty

4. Higher initial cost than other spraying techniques
5. A need to exercise extra care to avoid excessive buildup of paint that causes solvent entrapment, pinholes, runs, sags, and wrinkles

7.7.1.5 Powder Coating

Powder coatings have grown in popularity as anti-pollution coatings because of the absence of solvents. Coating thicknesses of 25 to 250 μm can be obtained.

Automotive bodies, electric components, and housing materials, wire and cables make use of this process. Polyethylene and epoxy resins are the predominant types of paints used. At the present time, the following procedures are used:

1. Pouring method (flock coating)
2. Rotational coating of pipes
3. Fluidized bed
4. Dipping in nonfluidizing powders
5. Centrifugal casting
6. Rotational molding
7. Electrostatic powder spraying
8. Electrostatic fluidized bed
9. Pouring or flowing of fluidized powder
10. Electrogas dynamics powder spraying
11. Flame spraying of thermoplastic powders

Powder coating was developed in the 1950s and is a method for applying finely divided, dry, solid, resinous coatings by dipping products in a fluidized bed or by spraying them electrostatically. The fluidized bed is essentially a modified dip tank. During the electrostatic spraying method, charged particles adhere to grounded parts until fused and cured. In all cases, the powder coating is heated to its melt temperature, where a phase change occurs, causing it to adhere to the product and fuse to form a continuous coating.

The fluidized bed powder coating is a dipping process using dry, finely divided plastic materials; a tank having a porous bottom plate forms the fluidized bed. The plenum below the porous plate uniformly supplies low-pressure air across the plate, which suspends the finely divided plastic powder particles. Products that are preheated above the melt temperature of the material are dipped into the bed where the powder melts and fuses into a continuous coating. Thermosetting powders often require additional heat to cure the film on the product.

Fluidized bed powder coating has the advantage of producing a uniform and reproducible film thickness. It also has the advantage of producing a heavy coating in one dip. The disadvantage of this method is the 3-mil minimum film thickness required to form a continuous coating.

An electrostatic fluidized-bed coater is essentially a fluidized bed with a high-voltage DC grid installed above the porous plate to charge the finely divided particles. The charged particles repel the grid and each other, forming a cloud. These particles are attracted to and coat products that are at ground potential. Film thicknesses of 1.5 to 5 mil are possible on cold parts and 20 to 25 mil are possible on heated parts.

The advantage of this method is that small parts such as electrical components can be coated uniformly and quickly. The disadvantage is that the product size is limited and inside corners have low film thickness.

Electrostatic spray coating is a method for applying finely divided, electrostatically charged particles to products that are at ground potential. A powder/air mixture from a small fluidized bed in a powder reservoir is supplied by hose to a spray gun that has a charged electrode in the nozzle fed by a high-voltage DC power pack. The spray guns can be manual or automatic and mounted in a conveyORIZED spray booth. Film thicknesses of 1.5 to 5 mil can be obtained on cold substrates. A 20- to 25-mil thickness can be obtained on heated substrates. The advantage of this method is that coatings using many resin types can be achieved in thicknesses of 1.5 to 3 mil, with no VOC emissions. Disadvantages include the difficulty in obtaining a continuous coating of less than 1 mil; and because of complex powder reclaiming systems, color changes are more difficult to make than with liquid spray systems.

7.7.1.6 Electrodeposition of Polymers

The electrodeposition of polymers is an extension of painting techniques into the field of plating and, like plating, is a dip coating process. In the case of ionizable polymers, the deposition reaction is:

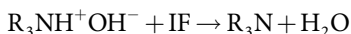

or the conversion of water-dispersed ammonium-type ions into ammonia-type, water-insoluble polymers known as cathodic deposition. Alternatively, a large number of installations utilize the anodic deposition process:

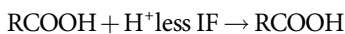

where R symbolizes any of the widely used polymers (such as acrylics, epoxies, alkyds, etc.). The electrodeposition process is defined as the utilization of synthetic, water-dispersed, electrodepositable macroions.

Metal ions, typically 0.5Ni^{2+} , show an electrical equivalent weight equal to approximately 29.5 g while the polymeric ions typically used for electrodeposition exhibit a gram equivalent weight (GEW) of approximately 1600. Therefore, IF plates out 30 g nickel and deposits 1600 g macroions.

The formation of uniformly thick coats on all surfaces of a formed work piece, including the extreme recesses, such as the inside of car doors, is probably the reason for the rapid industrial growth of this process. The ability to extend coats into recesses is known as "throwing power."

Another advantage is the very small emission of volatile organic compounds (VOCs), making electrodeposition with powder coating and radiation cure the least polluting coating process.

The anodic deposition process for paint coating systems was introduced in the early 1960s, and the cathodic deposition process in 1972. Electrodeposition processes are widely used because they possess the advantages of unmanned coating, automation, energy savings, and lower environmental pollution. This process is used to apply coatings to automotive bodies and parts, domestic electrical components, machine parts, and architectural such as window frames. Schematic illustrations of anodic and cathodic electrodeposition of paints are shown in Figure 7.4.

The primary paints used in the electrodeposition process are anionic-type resins with a carboxyl group (RCOOH polybutadiene resin) and cationic-type resins (R-NH₂ epoxy resin). Hydrophilic groups and neutralizing agents are added to the water-insoluble or undispersed prepolymer to convert them to soluble or dispersed materials.

The dissolution of metal substrate in the cathodic process is much less than that in the anodic process. The primary resins used in the cathodic process are epoxy; and because epoxy resins provide good water and alkali resistance as well as adhesion, cationic paint coatings are superior to anodic paint coatings.

7.7.2 Multilayer Coatings

The thicker a coating, the better the protective ability. However, the thickness of a single coat is restricted because thick paint films tend to crack as a result of the internal stress. When a product is to be used for an extended period of time in a severe environment, multilayer paint coating systems are usually employed. Automotive bodies and steel structures are typical products receiving multilayer coatings. A two- or three-coat system is employed for automotive bodies, and a general or heavy-duty coating system is adopted for steel structures. A typical paint coating system for an automotive body is as follows:

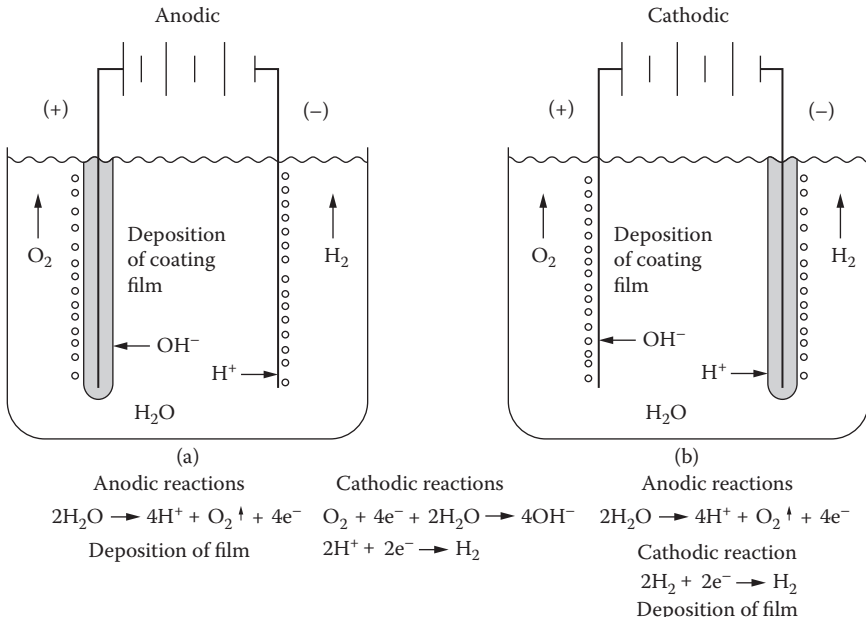
**FIGURE 7.4**

(a) Anodic and (b) cathodic electrodeposition of paints.

1. Pretreatment (degreasing and phosphating) by dipping or spraying
2. Primer coating by cathodic electrodeposition
3. Sealing by blow gun or undercoating by air spray
4. Surface conditioning by flattening
5. Intermediate spray coating by auto-electrostatic powder process or spraying
6. Surface conditioning by flattening and wax injection
7. Top paint coating by auto-electrostatic powder process, as by spray

The paint system for auto bodies is composed of a combination of various types of paint and effective coating processes, thereby providing optimal corrosion protection and decorative appearance.

The paint system for a steel structure is selected based on the required service life and environmental conditions under which the steel structure must exist. Structures in mild environments are commonly coated with general coating systems. Those in severe environments are treated with heavy-duty coating systems. Typical paint coating systems for steel structures are given in Table 7.11.

TABLE 7.11

Application Examples of Multistage Paint Coating Systems for Steel Structures

General Coating System				
	A	B	C	
1st coat	Etching primer	Etching primer	Zinc-rich primer	
2nd coat	Oil corrosion preventive paint	Oil corrosion preventive paint	Chlorinated rubber system primer	
3rd coat	Oil corrosion preventive paint	Oil corrosion preventive paint	Chlorinated rubber system primer	
4th coat	Long-oil alkyd resin paint	Phenolic resin system M10 paint	Chlorinated rubber system paint	
5th coat	Long-oil alkyd resin paint	Chlorinated rubber system paint	Chlorinated system rubber paint	
6th coat		Chlorinated rubber system paint		
Heavy Coating System				
	D	E	F	G
1st coat	Zinc spray or zinc-rich paint	Thick-type zinc-rich paint	Thick-type zinc-rich paint	Zinc-rich primer
2nd coat	Etching primer	Thick-type vinyl or chlorinated rubber system paint	Thick-type epoxy primer	Tar epoxy resin paint
3rd coat	Zinc chromate primer	Thick-type vinyl or chlorinated system rubber paint	Thick-type epoxy primer	Tar epoxy resin paint
4th coat	Phenolic resin system M10 paint	Vinyl or chlorinated rubber system paint	Epoxy resin system paint	Tar epoxy paint
5th coat	Chlorinated rubber system paint	Vinyl or chlorinated rubber system paint	Epoxy or polyurethane resin system paint	
6th coat	Chlorinated rubber system paint			

7.7.3 Curing

For a coating to be effective, it must be properly cured. Unless this is allowed to take place, the coating will not provide the protection required nor have the expected lifetime.

Most organic resins are liquid, which cure or dry to form solid films. They are classified as thermoplastic or thermosetting. Thermoplastic resins dry by solvent evaporation and will soften when heated and harden when cooled. Thermosetting resins will not soften when heated after they are cured. Most organic resins are affected by solvents. Table 7.12 lists organic resins and solvents that affect them.

Coatings are also classified by their various film-forming mechanisms, such as solvent evaporation, coalescing, phase change, and conversion. Additionally, they are classified as room-temperature curing (sometimes called air-drying) or heat curing (generally referred to as baking or forced drying), which uses elevated temperatures to accelerate drying. Thermoplastic and thermosetting coatings can be both air-drying and baking.

TABLE 7.12

Solvents That Affect Organic Resins

Resin	Heat-Distortion	
	Point (°F)	Solvents that Affect Surface
Acetal	338	None
Methyl methacrylate	169–195	Ketones, esters, aromatics
Modified acrylic	170–190	Ketones, esters, aromatics
Cellulose acetate	110–209	Ketones, some esters
Cellulose propionate	110–250	Ketones, esters, aromatics, alcohols
Cellulose acetate butyrate	115–227	Ketones, esters, aromatics, alcohols
Nylon	260–360	None
Polyethylene:		
High density	140–180	None
Medium density	120–150	None
Low density	105–121	None
Polypropylene	210–230	None
Polycarbonate	210–290	Ketones, esters, aromatics
Polystyrene (G.P. high heat)	150–195	Some aliphatics, ketones, esters, aromatics
Polystyrene (impact, heat resistant)	148–200	Ketones, esters, aromatics, some aliphatics
ABS	165–225	Ketones, esters, aromatics, alcohol

7.7.3.1 Air-Drying

Air-drying coatings cure at room temperatures, forming films. The films are formed by one of three mechanisms:

1. *Solvent evaporation.* Shellac and lacquers such as nitrocellulose, acrylic, styrene-butadiene, and cellulose acetate thermoplastic resins form films by solvent evaporation.
2. *Conversion.* As solvents evaporate, films are formed that are cured by oxidation, catalysis, or crosslinking. Thermosetting coatings crosslink to form films at room temperature by catalysis or oxidation. The addition of catalysts will accelerate the oxidative curing of drying oils and oil-modified resins. Monomeric materials can form films and cure by crosslinking with polymers in the presence of catalysts, as in the case of styrene monomers and polyester resins. Epoxy resins will crosslink with polyamine resins to form films and cure. Airborne moisture starts a reaction in the vehicle of polyurethane resin coating systems, resulting in film formation and cure.
3. *Coalescing.* Emulsion or latex coatings, such as styrene-butadiene, acrylic ester, and vinyl acetate acrylic, form films by coalescing and dry by solvent evaporation.

7.7.3.2 Baking

Coatings requiring baking will form films at room temperature but require elevated temperatures of 300 to 372°F (150 to 200°C) to cure. Curing is either by conversion or phase change.

- *Conversion.* Heating accelerates the cure of many oxidative thermosetting coatings. In resin systems such as thermosetting acrylics and alkyd melamines, the reactions will not take place below a temperature of 275°F (135°C). Coatings that require heat for curing are generally tougher than air-drying coatings. In some cases, the cured films are so hard that they must be modified with other resins.
- *Phase change.* Polyolefins, waxes, and polyamides are thermoplastic coatings that form films by phase changes — generally from solid to liquid, then back to solid. Plastics and organosols undergo phase changes during film formation. Fluidized-bed powder coatings, both thermoplastic and thermosetting, also undergo changes during film formation and cure.

7.7.3.3 Force Drying

The cure rate of many thermoplastic and thermosetting coatings can be accelerated by exposure to elevated temperatures that are below those considered as baking temperatures.

7.7.3.4 Reflowing

Certain thermoplastic coating films will soften and flow, becoming smooth and glossy at elevated temperatures. The automotive industry uses this technique on acrylic lacquers to eliminate buffing.

7.7.3.5 Radiation Curing

Bombardment with ultraviolet and electron-beam radiation with little increase in temperature will form and cure films. However, infrared radiation increases the surface temperature and it therefore is considered a baking process.

7.7.3.6 Vapor Curing

This method is used for two-component coatings. The substrate is coated with one component of the coating in the conventional manner. It is then placed in an enclosure filled with the other component — a curing agent in vapor form — where the catalysis or crosslinking conversion takes place.

7.7.4 Inspection

The most important part of a coating operation is to guarantee that the coating has been properly applied. It is better to have a less effective coating applied properly than the best coating applied poorly.

There are a wide variety of aids, standards, and inspection instruments available to check the quality of the coating system. These include devices for checking the cleanliness of a prepared surface, the depth of a blast-cleaning anchor pattern or profile, and various magnetic, eddy current, and nondestructive thickness gauges (capable of measuring the total thickness or the thickness of each coat in a multicoat system). In addition, there are instruments available to monitor temperature, humidity, and dew point on a continuous basis.

After application, adhesion tests and holiday tests (for pinholes and other discontinuities) can also be specified.

It is also important to realize that even if properly applied, the coating does not last forever. During the first 6 to 12 months after application, visual inspection will be able to detect inadvertent misses, thin spots, or weak areas in the coating. Repair, if required, should be done at this time.

As time passes, the coating will break down and deteriorate as a result of the environment. Because of this, scheduled inspections should be conducted. Localized areas of failure should be touched up before deterioration of the entire surface occurs.

If a scheduled maintenance program of periodic touch-up, followed occasionally by a full coat over the entire area, is followed, the expensive costs of total surface preparation (such as complete media blasting for removal of all old coating) can be avoided, sometimes for 30 years or more.

Corrosion protection by coatings can be economically achieved for long periods of time if the entire coating procedure is followed from beginning to end, starting with a definition of the environment, selection of the proper coating system, proper surface preparation and application, inspection, and periodic maintenance and repair.

7.8 Maintenance of the Coating

Any paint job, even if properly done, does not last forever. Over a period of time, the coating will break down and deteriorate as a result of the effect of the environment. Scheduled inspections should be made to determine the extent and rate of coating breakdown. Spot touch-up repair should be made at localized areas of failure before deterioration of the entire coated surface has taken place. Extensive costs of total surface preparation can be avoided if a planned maintenance approach of periodic spot touch-up and an occasional recoat of the entire surface is followed.

Many coatings that provide good long-term protection are more difficult to touch up or repair in the event of physical damage or localized failure. This is particularly true of the thermosetting and zinc-rich coatings. Application of a subsequently applied paint coat to an older-aged epoxy, urethane, or other catalyzed coating often results in reduced adhesion that leads to peeling.

Thermoplastic coatings do not usually present this problem. Solvents of freshly applied thermoplastic coatings soften and allow for intermolecular mixing of the new and old coatings with good intercoat adhesion.

Heavily pigmented coatings, such as zinc-rich, require agitated pots to keep the pigment in suspension during application. Because of this, touch-up and repair of large areas is not recommended using zinc-rich coatings unless it is done by spray using an agitated pot.

For the most part, oil-based coatings (alkyds, epoxy esters, and modifications thereof) have a greater tolerance for poor surface preparation and an ability to wet, penetrate, and adhere to poorly prepared surfaces or old coatings. Consequently, these coatings are often specified for these purposes, although they do not provide as long a term of corrosion protection.

7.9 Selecting a Paint System

The first step in selecting a paint system for corrosion protection is to determine the environment around the structure or item to be painted. Is the environment predominantly a weathering environment subject to heat, cold, daily or seasonal temperature changes, precipitation, wind (flexing), exposure to sunlight, or detrimental solar rays? If the structure or item is located outdoors, are there chemical plants nearby, or pulp and paper mills, or other industrial facilities that are apt to discharge airborne pollutants? Is color, gloss, and overall pleasing effect more important than corrosion protection, or are the normal grays, whites, and pastels of the more corrosion-resistant paints satisfactory? If located in a chemical facility, what specific chemicals are used nearby? Is there any chance of a chemical spill on the painted surface?

Because surface preparation is an important factor in the selection of a paint system, the suitability or availability of the surface for specific preparation techniques must be known. In some instances, certain types of surface preparation may not be permitted or practical. For example, many companies do not permit open blast cleaning where there is a prevalence of electric motors or hydraulic equipment. Refineries, in general, do not permit open blast cleaning or any other method of surface preparation that might result in the possibility of a spark, static electricity buildup, or an explosion hazard.

If a new facility is being constructed, it is possible that during erection many areas may become enclosed or covered or so positioned that access is difficult or impossible. These structures must be painted prior to installation.

When all this information has been collected, appropriate paint systems may be selected. In most instances, it will not be practical or possible to select one single coating system for the entire plant. There will be areas requiring systems to provide protection from aggressive chemicals, whereas other areas may require coating systems simply for aesthetics. If an area is a combination of mild and aggressive conditions, a coating system should be selected that will be resistant to the most aggressive condition.

Several typical industrial areas have been illustrated that coating systems may be exposed to, with recommendations for paint systems to be used in these areas. The paint systems are shown in Table 7.13 through Table 7.18 with the appropriate surface preparation. These tables have been arranged based on surface preparation. Each coating system shown in a particular table requires the same surface preparation.

TABLE 7.13

Multilayer Paint Systems Requiring Commercial Blast (SSPC-SP-6) for Surface Preparation

System A Inorganic-Zinc/Epoxy Mastic

Paint Layers:

- One coat inorganic zinc: 2–3 mil dft (50–75 μm)
- One coat epoxy mastic: 4–6 mil dft (100–150 μm)

Properties:

Zinc primer provides outstanding corrosion resistance and undercutting resistance
 A barrier protection for the zinc primer is provided by the finish coat of epoxy, which also provides a color coat for appearance
 Suitable for use on carbon steel only

Limitations:

A relatively high level of applicator competence required for the primer

System B Inorganic Zinc/Epoxy Primer/Polyurethane Finish

Paint Layers:

- One coat inorganic zinc: 2–3 mil dft (50–75 μm)
- One coat epoxy primer: 4–6 mil dft (100–150 μm)
- One coat polyurethane finish: 2–4 mil dft (50–100 μm)

Properties:

Zinc primer provides outstanding corrosion resistance and undercutting resistance
 The zinc primer is protected by a barrier coating of epoxy primer, while the finish coat of polyurethane provides color and gloss retention
 This is a premium industrial finish for steel surfaces
 Can only be used on carbon steel

Limitations:

A relatively high level of applicator competence required for the primer

System C Inorganic Zinc/Acrylic Finish

Paint Layers:

- One coat inorganic zinc: 2–3 mil dft (50–75 μm)
- One coat acrylic finish: 2–3 mil dft (50–15 μm)

Properties:

Zinc primer provides outstanding corrosion resistance and undercutting resistance
 Water-based single-package finish has excellent weathering and semigloss appearance

Limitations:

A relatively high level of applicator competence required for the primer
 The finish coat has low temperature curing restrictions

—continued

TABLE 7.13 (continued)

Multilayer Paint Systems Requiring Commercial Blast (SSPC-SP-6) for Surface Preparation

System D Aluminum Epoxy Mastic/Epoxy Finish

Paint Layers:

One coat aluminum epoxy mastic: 4–6 mil dft (100–150 μm)

One coat epoxy finish: 4–6 mil dft (100–150 μm)

Properties:

Can be used on tight rust and marginally prepared surface

The epoxy finish coat is available in a variety of colors and has good overall chemical resistance

May be used on carbon steel or concrete

Concrete must be clean, rough, and cured at least 28 days

Hand or power tool cleaning, including water blasting, may be used for surface preparation

System E Aluminum epoxy mastic/acrylic finish

Paint Layers:

One coat aluminum epoxy mastic: 4–6 mil dft (100–150 μm)

One coat acrylic finish: 2–3 mil dft (50–75 μm)

Properties:

May be used on tight rust and marginally prepared surfaces

The acrylic finish coat is available in a variety of colors and has good overall chemical resistance

This is an excellent maintenance system

Normally used on carbon steel and concrete

System F Epoxy Mastic/Epoxy Mastic

Paint Layers:

One coat epoxy mastic: 4–6 mil dft (100–150 μm)

One coat epoxy mastic: 4–6 mil dft (100–150 μm)

Properties:

May be used on tight rust and marginally prepared surfaces

The substrate is protected by the formation of a tight barrier stopping moisture from reaching the surface

Normally used on steel or concrete

Concrete must be clean, rough, and cured at least 28 days

If necessary, hand or power tools may be used for cleaning

System G Epoxy Primer/Epoxy Finish

Paint Layers:

One coat epoxy primer: 4–6 mil dft (100–150 μm)

One coat epoxy finish: 4–6 mil dft (100–150 μm)

—continued

TABLE 7.13 (continued)
Multilayer Paint Systems Requiring Commercial Blast (SSPC-SP-6) for Surface Preparation

Properties:

An easily applied two coat high build barrier protection is provided with ease of application
Used on carbon steel or concrete

Limitations

Because these are two-component materials, they must be mixed just prior to application
They require additional equipment and more expertise to apply than a single-packed product
Many epoxy finish coats will chalk, fade, and yellow when exposed to sunlight

System H Epoxy Primer

Paint layers:

One coat epoxy primer: 4–6 mil dft (100–150 μm)

Properties:

Normally applied to carbon steel or concrete in protected areas such as the interiors of structures, behind walls and ceilings, or for temporary protection during construction

Limitations:

This is a two-component material requiring mixing just prior to application

System I Epoxy Novalac/Epoxy Novalac

Paint Layers:

One coat epoxy novalac: 6–8 mil dft (150–200 μm)

One coat epoxy novalac: 6–8 mil dft (150–200 μm)

Properties:

An exceptional industrial coating for a wide range of chemical resistance and physical abuse resistance

Has a higher temperature resistance than standard epoxy

May be used to protect insulated piping or for secondary containment

Normally used on carbon steel and concrete surfaces

TABLE 7.14

Multilayer Paint Systems Requiring That Surface Be Abrasive Blasted in Accordance with SSPC-SP-10 Near-White Blast

System A Aluminum-Epoxy Mastic/Aluminum-Epoxy Mastic
<i>Paint Layers:</i>
One coat aluminum-epoxy mastic: 4–6 mil dft (100–150 μm)
One coat aluminum-epoxy mastic: 4–6 mil dft (100–150 μm)
<i>Properties:</i>
Tolerates poorly prepared surfaces and provides excellent barrier protection
A third coat may be added for additional protection
Can be used on carbon steel and concrete
Concrete must be clean, rough, and cured at least 28 days
If necessary, this system can be applied to surfaces that are pitted or cannot be blasted, but the service life will be reduced
System B Epoxy Phenolic Primer/Epoxy Phenolic Finish/Epoxy Phenolic Finish
<i>Paint Layers:</i>
One coat epoxy phenolic primer: 8 mil dft (200 μm)
One coat epoxy phenolic finish: 8 mil dft (200 μm)
One coat epoxy phenolic finish: 8 mil dft (200 μm)
<i>Properties:</i>
Because of this system's outstanding chemical resistance, it is often used in areas subject to frequent chemical spills
The finish coats are available in a limited number of colors
Normally used on carbon steel and concrete. Concrete must be clean, rough, and cured at least 28 days
System C Epoxy Phenolic Primer/Epoxy Phenolic Lining/ Epoxy Phenolic Lining
<i>Paint Layers:</i>
One coat epoxy phenolic primer: 8 mil dft (200 μm)
One coat epoxy phenolic lining: 8 mil dft (200 μm)
One coat epoxy phenolic lining: 8 mil dft (200 μm)
<i>Properties:</i>
Because of this system's overall chemical resistance, it is suitable for lining areas subject to flowing or constant immersion in a variety of chemicals
Normally used on carbon steel and concrete
When used on concrete, the surface must be clean, rough, and cured at least 28 days
System D Epoxy/Epoxy
<i>Paint Layers:</i>
One coat epoxy: 4–6 mil dft (100–150 μm)
One coat epoxy: 4–6 mil dft (100–150 μm)

—continued

TABLE 7.14 (continued)

Multilayer Paint Systems Requiring That Surface Be Abrasive Blasted in Accordance with SSPC-SP-10 Near-White Blast

Properties:

Two coats of the same product are applied, providing a high build protection
 Can be used in immersion service without the addition of corrosion inhibitors
 When used in potable water systems, the product must meet Federal Standard 61
 A third coat may be added for additional protection
 Normally used on carbon steel and concrete

System E Coal Tar Epoxy/Coal Tar Epoxy

Paint Layers:

One coat coal tar epoxy: 8 mil dft (200 μm)
 One coat coal tar epoxy: 8 mil dft (200 μm)

Properties:

Provides excellent barrier protection and is the most economical of the water lining systems for water immersion
 Normally used on carbon steel and concrete

System F Solventless Elastomeric Polyurethane

Paint Layers:

One coat solventless elastomeric polyurethane: 20–250 mil dft (500–6250 μm)

Properties:

Excellent barrier protection
 Normally used on carbon steel and concrete

Limitations:

Must be applied by a knowledgeable contractor

7.9.1 Area 1: Mild Exposure

This is an area where structural steel is embedded in concrete, encased in masonry, or protected by noncorrosive type fire-proofing. In many instances, no coating will be applied to the steel. However, it is a good idea to coat the steel substrate with a protective coating to protect it during construction and in case it ends up being intentionally or unintentionally exposed.

A good practice would be to apply a general-use epoxy primer, 3 to 5 mil dry film thickness (dft) (75 to 125 μm). If the surface cannot be abrasive-blasted, a surface-tolerant epoxy mastic may be used.

Recommended systems are found in Table 7.16, systems A and C.

TABLE 7.15

Multilayer Paint Systems Requiring Surface to Be Clean, Dry, and Free of Loose Dirt, Oils, and Chemical Contamination

System A Aluminum Epoxy Mastic/Polyurethane Finish

Paint Layers:

One coat aluminum epoxy mastic: 4–6 mil dft (100–150 μm)

One coat polyurethane finish: 2–4 mil dft (50–100 μm)

Properties:

Excellent over tight rust

Tolerant of minimally prepared steel

May be applied to a wide range of surfaces, but normally used on carbon steel and concrete

This is a premium system to use when cleaning must be minimal

Limitations:

To cure properly, temperature must be above 50°F (10°C)

For lower temperature requirements, other aluminum epoxy/urethane mastics may be substituted

7.9.2 Area 2: Temporary Protection, Normally Dry Interiors

This area consists of office space or dry storage areas (warehouses) or other locations exposed to generally mild conditions or areas where oil-based paints presently last for 10 or more years. If located in an industrial environment, there is the possibility of exposure to occasional fumes, splashing, or spillage of corrosive materials. Because of this, it is suggested that an industrial-grade acrylic coating system or a single coat of epoxy be applied.

This recommendation is not suitable for interior surfaces that are frequently cleaned or exposed to steam cleaning. Refer to Area 4. Recommended for this area are systems A and C in Table 7.16.

7.9.3 Area 3: Normally Dry Exteriors

This includes such areas as parking lots, water storage tanks, exterior storage sheds, and lighting or power line poles that are exposed to sunlight in a relatively dry location. Under these conditions, oil-based paints should last 6 or more years. Those materials that are resistant to UV rays and are normally rated for exterior use include acrylics, alkyds, silicones, and polyurethanes.

Epoxies will lose gloss, normally chalk, and fade rapidly when exposed to UV rays. Recommended systems include A in Table 7.15, C in Table 7.16, A in Table 7.17, and A in Table 7.18.

TABLE 7.16

Multilayer Paint Systems for New, Clean, Surfaces Free of Chemical Contamination

System A Epoxy Mastic
<i>Paint Layers:</i>
One coat epoxy mastic: 3–5 mil dft (75–125 μm)
<i>Properties:</i>
Good color selection, excellent chemical resistance, and good physical characteristics, ease of maintenance
Used on carbon steel, concrete masonry units, masonry block (a filler is recommended), sheet rock (a sealer is required), wood, polyvinyl chloride, galvanized steel, and other surfaces
<i>Limitations:</i>
This is a two-component material that is mixed just prior to application
Additional equipment is required and more expertise to apply than a single-packaged product
Epoxy solvents may be objectionable to some people
System B Acrylic Primer/Acrylic Intermediate/Acrylic Finish
<i>Paint Layers:</i>
One coat acrylic primer: 2–3 mil dft (50–75 μm)
One coat acrylic intermediate: 2–3 mil dft (50–75 μm)
One coat acrylic finish: 2–3 mil dft (50–75 μm)
<i>Properties:</i>
A single-package, water-based, low-odor, semigloss paint
Possesses excellent weathering and acid resistance
Can be used on most surfaces including carbon steel, concrete, concrete masonry units, masonry block (a block filler is recommended), sheet rock (a sealer is required), wood, polyvinyl chloride, galvanized steel, stainless steel, copper, and fabric
May be applied over existing coatings of any type, including inorganic zinc
<i>Limitations:</i>
Must be protected from freezing during shipping and storage
For application, temperature must be above 60°F (16°C) and will remain so for 2–3 hours after application
System C Acrylic Primer/Acrylic Finish
<i>Paint Layers:</i>
One coat acrylic primer: 2–3 mil dft (50–75 μm)
One coat acrylic finish: 2–3 mil dft (50–75 μm)
<i>Properties:</i>
Excellent weathering and acidic chemical resistance, with good color selection
<i>Limitations:</i>
For best performance, metallic surfaces should be abrasive blasted
For mild conditions, hand or power cleaning may be sufficient
Paint must be applied when temperature exceeds 60°F (16°C)

TABLE 7.17

Multistage Paint Systems Requiring an Abrasive Blast to the Substrate Surface

System A Epoxy Primer/Polyurethane Finish*Paint Layers:*One coat epoxy primer: 3–5 mil dft (75–125 μm)One coat polyurethane finish: 2–3 mil dft (50–75 μm)*Properties:*

Two-coat protection is provided with excellent high-gloss finish and long-term color gloss retention

Normally applied to carbon steel and concrete

Limitations:

Because these are two-component materials, they must be mixed just prior to application and require additional equipment and more expertise to apply

TABLE 7.18

Multilayer Paint Systems for Previously Painted Surfaces That Have Had Loose Paint and Rust Removed by Hand Cleaning

*Paint Layers:*One coat oleoresin: 2–4 mil dft (50–100 μm)*Properties:*

This very slow-drying material penetrates and protects existing surfaces that cannot be cleaned properly with a single coat

Provides long-term protection without peeling, cracking, and other such problems

Easy to apply by spray, brush, roller, or glove

Normally used on carbon steel and weathering galvanized steel

Limitations:

This material is designed to protect steel that will not see physical abuse

It also stays soft for an extended period of time

7.9.4 Area 4: Freshwater Exposure

Under this category, the surface to be protected is frequently wetted by freshwater from condensation, splash, or spray. Included are interior or exterior areas that are frequently exposed to cleaning or washing, including steam cleaning.

The systems used for these surfaces make use of inorganic zinc as a primer. Inorganic zinc is the best coating that can be applied to steel because it provides the longest term of protection. In some instances, it may be necessary to substitute an organic zinc (an organic binder such as epoxy or polyurethane with zinc added) for the inorganic zinc.

Recommended systems are B, C, and E in Table 7.15.

7.9.5 Area 5: Saltwater Exposure

This area includes interior or exterior locations on or near a seacoast or industrial environments handling brine or other salts. Under these conditions, the surfaces are frequently wetted by saltwater and include condensation, splash, or spray.

Conditions in this area are essentially the same as for freshwater and the comments for Area 4 apply here. Because of the more severe conditions, it is recommended that two coats of the primer be applied for system E in Table 7.13 and system A in Table 7.15.

Recommended systems are B, C, and E in Table 7.13 and A in Table 7.15.

7.9.6 Area 6: Freshwater Immersion

Wastewaters are also a part of this area. Included are all areas that remain underwater for periods longer than a few hours at a time. Potable and nonpotable water, sanitary sewage, and industrial waste liquids are all included.

If the systems recommended are to be used as tank linings, it is important that the application be performed by experienced workers. In addition, if the coating to be applied will be in contact with potable water, it is important that the material selected meets the necessary standards and is approved for use by the health department. Two coats of epoxy (system D in Table 7.14) are frequently used in this service.

Recommended systems are F in Table 7.13 and A, D, and E in Table 7.14.

7.9.7 Area 7: Saltwater Immersion

Areas that remain underwater in a coastal environment or industrial area or that are constantly subjected to flowing salt or brine-laden water are included in this category. Because of the increased rate of corrosion, a third coat may be added to system F in Table 7.13 and systems A and E in Table 7.14 as additional protection against this more severe corrosion.

System D in Table 7.13 and systems A, E, and F in Table 7.14 are recommended for this service.

7.9.8 Area 8: Acidic Chemical Exposure (pH 2.0–5.0)

In the chemical process industries, this is one of the most severe environments encountered. When repainting, it is important that all surfaces are clean of any chemical residue. Inorganic zinc and zinc-filled coatings are not recommended for application in this area.

The system selected will be based on the quality of surface preparation, length of chemical exposure, and housekeeping procedures. Decreased

cleanup and longer exposure times require a more chemical-resistant coating system such as system I in Table 7.13.

Other recommendations for this area include systems D, G, and I in Table 7.13 and system B in Table 7.16.

7.9.9 Area 9: Neutral Chemical Exposure (pH 5.0–10.0)

This is an area that is not subject to direct chemical attack, but may be subject to fumes, spillage, or splash. Under these conditions, more protection is required than will be provided by a standard painting system. This would include such locations as clean rooms, packaging areas, hallways, enclosed process areas, instrument rooms, electrical load centers, and other similar locations.

A list of potential chemicals that may contact the coating aids in the coating selection. Knowledge of cleanup procedures will also prove helpful. It may be possible to use systems requiring less surface preparation, such as system D in Table 7.13, system A in Table 7.15, system A in Table 7.16, and system A in Table 7.17.

Recommendations for Area 9 are systems A and D in Table 7.13, system A in Table 7.15, systems A and C in Table 7.16, and system A in Table 7.17.

7.9.10 Area 10: Exposure to Mild Solvents

This is intended for locations subject to intermittent contact with aliphatic hydrocarbons such as mineral spirits, lower alcohols, glycols, etc. Such contact can be the result of splash, spillage, or fumes.

Crosslinked materials, such as epoxies, are best for this service because solvents will dissolve single-package coatings. A single coat of inorganic zinc is an excellent choice for immersion service in solvents or for severe splashes and spills.

The gloss of a coating system is often reduced as a result of solvent splashes or spills. However, that is a surface effect that usually does not affect the overall protective properties of the coating.

Recommended systems for use in this location are A, D, and G in Table 7.13.

7.9.11 Area 11: Extreme pH Exposure

This covers locations that are exposed to strong solvents, extreme pH, oxidizing chemicals, or combinations thereof with high temperatures. The usual choices for coating these areas are epoxy novalacs, epoxy phenolics, and high-build polyurethanes. Other special coatings such as the polyesters and vinyl esters may also be considered. However, these systems require special application considerations.

Regardless of which coating system is selected, surface preparation is important. An abrasive blast, even on concrete, is required. In addition, all

surface contaminants must be removed. When coating concrete, a thicker film is required. System F in Table 7.14 is recommended for optimum protection.

Recommended for this location is system I in Table 7.13, and systems B, C, and F in Table 7.14.

The foregoing have been generalizations as to what environmental conditions may be encountered, along with suggested coating systems to protect the substrate. Data presented will act as a guide in helping the reader select the proper coating system. Keep in mind that the surface preparation is critical and should not be skimmed on.

8

Corrosion of Metallic Coatings

Metallic coatings on a metal substrate are applied for several purposes, including improved appearance, improved wear resistance, influence on the solderability of materials, and corrosion resistance. The selection of the type of metal coating and the application method both depend on the properties required for the application. This chapter is primarily concerned with the application of metallic coatings for the purpose of corrosion protection. Because metallic corrosion almost always proceeds electrochemically in the material environment, the electrochemical principle of corrosion protection by coatings is discussed.

Commonly used corrosion-resistant coatings are classified into five categories on the basis of electrochemical principles:

1. Eclipse Molding Framework (EMF) control protection
2. Cathodic control protection
3. Anodic control protection
4. Mixed control protection
5. Resistance control protection

Theories of these protective abilities can be explained by the mechanisms of the corrosion cell.

8.1 Corrosion Cell

In a natural environment, the corrosion of most metals occurs and proceeds electrochemically. That is, the corrosion cell is formed on a metal surface in an atmosphere in which oxygen and water are present, as shown in Figure 8.1. The electrochemical reactions in the corrosion cell are written in the general form:

Anodic reaction: $M \rightarrow M^{n+} + ne^{-}$ (M = metal)

Cathodic reaction:

in acidic solution: $2H^{+} + 2e^{-} \rightarrow H_2$

in neutral and alkaline solutions: $O_2 + 2H_2O + 4e^{-} \rightarrow 4OH^{-}$

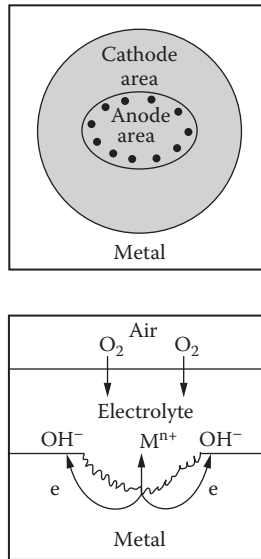

FIGURE 8.1
Structure of the corrosion cell.

The mechanism of the corrosion cell is represented in Figure 8.2 using the Evans diagram. In the Evans diagram, the cathodic current is expressed in the same direction as the anodic current.

In Figure 8.2, E_a shows the single potential for metal/metal ion equilibria at the anode, and E_c shows the single potential for H_2/H^+ , or for O_2/OH^- equilibria at the cathode. The single potential is given by the Nernst equation, that is,

$$E = E^\circ + \frac{RT}{nF} \ln a$$

where E is the single potential, E° is the standard single potential, R is the gas constant, T is the absolute temperature, n is the charge on the ion, F is the Faraday constant, and a is the activity of the ion. E is equal to E° when a is equal to 1. The standard single potential is E° and it shows the degree of activity of, for example, metal and gas.

Table 8.1 shows the standard single potential of various metal and non-metal reactants. The arrangement of metals in order of electrode potential is called the electrochemical series: the more negative the single potential, the more active the metal. When the corrosion circuit is formed, that is, when the electromotive force ($E_c - E_a$) is supplied, the current flows between the anode and the cathode. The anode electrode potential is shifted to the noble direction, the cathodic electrode potential is also shifted, but to the less noble

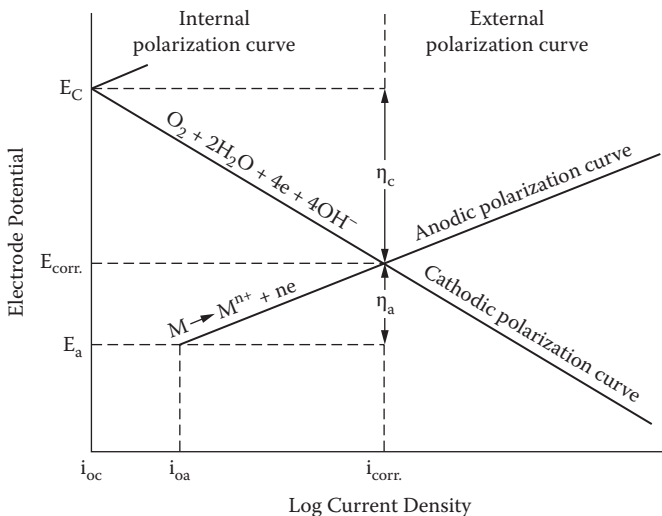

FIGURE 8.2
Mechanism of the corrosion cell.

direction. The behaviors of these electrode potentials are called anodic and cathodic polarization. Each reaction-rate curve ($E-i$ curve) is also called an anodic or cathodic polarization curve.

The intersection of anodic and cathodic polarization curves shows the corrosion potential, E_{corr} , and the corrosion current i_{corr} . Thus, the anodic and cathodic electrodes react at the same rate in the corrosion process.

The polarization curves in the current density range $<i_{corr}$ are called internal polarization curves and those in the current density range $>i_{corr}$ are called external polarization curves. The external polarization curve can be determined by sweeping the electrode potential from the corrosion potential to the anodic or cathodic direction. On the other hand, the internal polarization curve cannot be measured directly by the electrochemical technique because it is impossible to pick up the current separately from the anode and the cathode, which exist in an electrode. The internal polarization curves are determined by analysis of metallic ions dissolved and oxidizer reaction.

The difference in potential between E_{corr} and E_a or between E_{corr} and E_c is called anodic overpotential or cathodic overpotential, and is expressed by η_a or η_c ; that is,

$$\eta_a = E_{corr} - E_a \quad (\eta_a > 0)$$

$$\eta_c = E_{corr} - E_c \quad (\eta_c < 0)$$

TABLE 8.1
Standard Single Potentials, E°

Active		Inert	
Electrode (V, SHE, 25°C)	E°	Electrode (V, SHE, 25°C)	E°
Li/Li ⁺	-3.01	Mo/Mo ³⁺	-0.2
Rb/Rb ⁺	-2.98	Sn/Sn ²⁺	-0.140
Cs/Cs ⁺	-2.92	Pb/Pb ²⁺	-0.126
K/K ⁺	-2.92	H ₂ /H ⁺	±0
Ba/Ba ²⁺	-2.92	Bi/BiO ⁺	+0.32
Sr/Sr ²⁺	-2.89	Cu/Cu ²⁺	+0.34
Ca/Ca ⁺	-2.84	Cu/Cu ⁺	+0.52
Na/Na ⁺	-2.71	Rh/Rh ²⁺	+0.6
Mg/Mg ²⁺	-2.38	Hg/Hg ⁺	+0.798
Th/Th ⁴⁺	-2.10	Ag/Ag ⁺	+0.799
Ti/Ti ²⁺	-1.75	Pd/Pd ²⁺	+0.83
Be/Be ²⁺	-1.70	Ir/Ir ³⁺	+1.0
Al/Al ³⁺	-1.66	Pt/Pt ²⁺	+1.2
V/V ²⁺	-0.5	Au/Au ³⁺	+1.42
Mn/Mn ²⁺	-1.05	Au/Au ⁺	+1.7
Zn/Zn ²⁺	-0.763	O ₂ /OH ⁻	+0.401
Cr/Cr ³⁺	-0.71	I ² /I ⁻	+0.536
Fe/Fe ²⁺	-0.44	Br ₂ /Br ⁻	+1.066
Cd/Cd ²⁺	-0.402	Cl ₂ /Cl ⁻	+1.356
In/In ³⁺	-0.34	F ₂ /F ⁻	+2.85
Ti/Ti ⁺	-0.355	S/S ²⁻	-0.51
Co/Co ²⁺	-0.27	Se/Se ²⁺	-0.78
Ni/Ni ²⁺	-0.23	Te/Te ²⁺	-0.92

η_a/i_{corr} or η_c/i_{corr} represent the anodic or the cathodic reaction resistance. The corrosion reaction starts as soon as the cell circuit is formed. That is,

$$E_c - E_a = \left| \eta_c \right| + \eta_a + i_{\text{corr}} R$$

where R is the resistance of the electrolyte between the anode and cathode. Thus, the electromotive force of a corrosion cell is dissipated as the corrosion current passes through three processes: the anodic process, the cathodic process, and the transit process in the electrolyte.

In general, when the electrode is polarized, the overpotential η observed is composed of the activation overpotential η^a and the concentration overpotential η^c (Figure 8.3.) That is,

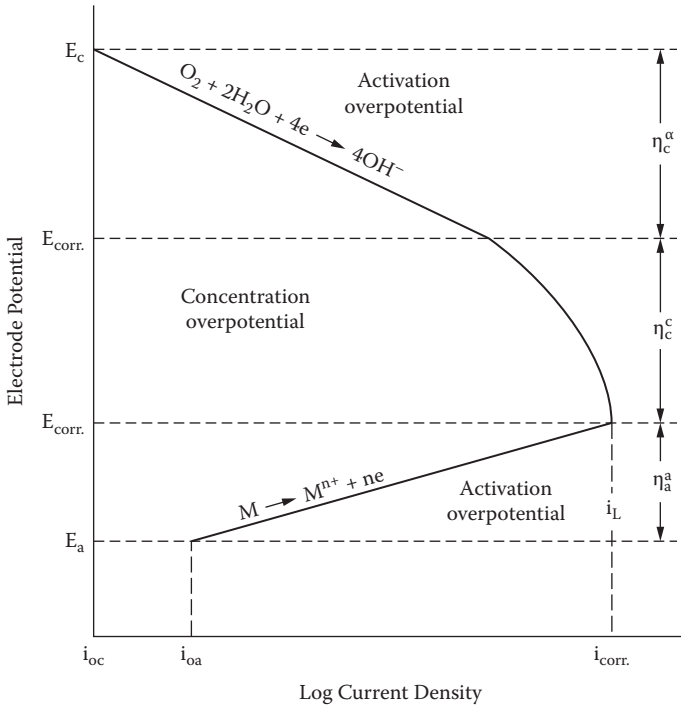

FIGURE 8.3 Activation and concentration overpotentials in a typical corrosion process.

$$\eta = \eta^a + \eta^c$$

The activation overpotential- η^w results from the potential energy barrier to overcome for a charge to cross the electrical double layer at the interface (that is, $M \leftrightarrow M^{n+} + ne^-$) and is given as follows:

In the anodic reaction,

$$\eta_a^a = \beta_a \log \frac{i_a}{i_{oa}}$$

$$\beta_a = 2.3 \frac{RT}{\alpha nF}$$

In the cathodic reaction,

$$\eta_c^a = \beta_c \log \frac{i_c}{i_{oc}}$$

$$\beta_c = \frac{2.3RT}{(1-\alpha)nF}$$

where η_a^a and η_c^a are the activation overpotentials in the anodic and cathodic reactions, β_a and β_c are the anodic and cathodic Tafel coefficients, α is the transfer coefficient, i_a and i_c are the anodic and cathodic current densities, and i_{oa} and i_{oc} are the exchange current densities of the anodes and cathodes, respectively. The energy transfer factor, α , indicates the degree of contribution of electrical energy for the activation energy in the electrode reaction ($0 < \alpha < 1$). In most cases, α is 0.3 to 0.7. The exchange current density, i_{oa} or i_{oc} , is the flux of charge that passes through the electrical double layer at the single-equilibrium potential, E_a or E_c . Other factors have been mentioned already. There is a linear relationship between η^a and $\log i_a$ or i_c . Tafel coefficient β_a or β_c is the slope, $d\eta^a/d(\log i_a \text{ or } i_c)$, of the polarization curve, so that β is one of the important factors that control the corrosion rate.

Generally, activation overpotential controls the electrode reaction at the low reaction rate. The cathodic reaction $2H^+ + 2e^- \rightarrow H_2$ is, in the acid solution, one of the processes controlled by the activation overpotential. Table 8.2 shows hydrogen overpotentials of various metals. The activation overpotential varies with the kind of metal and the electrolytic condition. In most cases, metal dissolution and metal-ion deposition are controlled by the activation overpotential.

Therefore, the anodic overpotential η_a is usually given by:

$$\eta_a = \beta_a \log \frac{i_a}{i_{oa}}$$

On the other hand, the concentration overpotential becomes the controlling factor in the electrode reaction at high reaction rate; in this case the electrode reaction is controlled by the mass transfer process, that is, the diffusion rate of reactive species. According to the diffusion layer concept, the diffusion current is given as:

$$i = \frac{nFD(C - C_o)}{\delta} \quad (8.1)$$

TABLE 8.2

Hydrogen Overpotentials of Various Metals

Metal	Temperature (°C)	Solution	Hydrogen Overpotential	Tafel Coefficient	Exchange Current Density
			$ \eta_c $ (V/mA/cm ²)	$ \beta_c $ (V)	$ i_{oc} $ (A/cm ²)
Pt (smooth)	20	1 N HCl	0.00	0.03	10 ⁻³
Mo	20	1 N HCl	0.12	0.04	10 ⁻⁶
Au	20	1 N HCl	0.15	0.05	10 ⁻⁶
Ag	20	0.1 N HCl	0.30	0.09	5 × 10 ⁻⁷
Ni	20	0.1 N HCl	0.31	0.10	8 × 10 ⁻⁷
Bi	20	1 N HCl	0.40	0.10	10 ⁻⁷
Fe	16	1 N HCl	0.45	0.15	10 ⁻⁶
Cu	20	0.1 N HCl	0.44	0.12	2 × 10 ⁻⁷
Al	20	2 N H ₂ SO ₄	0.70	0.10	10 ⁻¹⁰
Sn	20	1 N HCl	0.75	0.15	10 ⁻⁸
Cd	16	1 N HCl	0.80	0.20	10 ⁻⁷
Zn	20	1 N H ₃ SO ₄	0.94	0.12	1.6 × 10 ⁻¹¹
Pb	20	0.01–8 N HCl	1.16	0.12	2 × 10 ⁻¹³

where i is the current density, D is the diffusion coefficient, C is the concentration of reactive species in the bulk solution, C_o is the concentration of the reactive species at the interface, and δ is the thickness of diffusion layer. When the concentration of reactive species at the interface is zero ($C_o = 0$), the current density shows some critical values, i_L (called the limiting current density); that is,

$$i_L = \frac{nFDC}{\delta} \quad (8.2)$$

From Equations 8.1 and 8.2,

$$\frac{C_o}{C} = 1 - \frac{i}{i_L} \quad (8.3)$$

while the concentration overpotential η^c is given as:

$$\eta^c = \left(2.3 \frac{RT}{nF} \right) \log \left(\frac{C_o}{C} \right) \quad (8.4)$$

From Equations 8.3 and 8.4,

$$\eta^c = \frac{2.3RT}{nF} \log \left(1 - \frac{i}{i_L} \right) \quad (8.5)$$

Equation 8.5 shows that the concentration overpotential increases rapidly as i approaches i_L , as shown in Figure 8.3.

In general, the cathodic reaction is controlled by the activation overpotential η_c^a and the concentration overpotential η_c^c . The cathodic overpotential is

$$\eta_c = \eta_c^a + \eta_c^c \quad (8.6)$$

Therefore, from Equations 8.4 and 8.5 the cathodic overpotential is written in the general form:

$$\eta_c = \beta_c \log \frac{i_c}{i_{oc}} + \frac{2.3RT}{nF} \log \left(1 - \frac{i_c}{i_{cl}} \right) \quad (8.7)$$

In most cases, the importance of anodic and cathodic overpotentials is to determine the corrosion rate. That is, the rate-determining process is determined by the slopes of two polarization curves. Figure 8.3 shows the schematic illustration of activation and concentration overpotentials in the typical corrosion process.

Corrosion control processes are classified into four types by the patterns of anodic and cathodic polarization curves: anodic, mixed, cathodic, and resistance controls, as shown in Figure 8.4.

The role of a coating is to isolate the substrate from the atmosphere. The isolating action is based on two characteristics of coating materials: (1) the corrosion resistance or the stability of coating material when coating is formed by the defect-free continuous layer, and (2) the electrochemical action of the coating material when the coating has some defect, such as pore and crack. This action for a coating layer can be explained by applying the mechanism of the corrosion cell. For better understanding, the equation

$$E_c - E_a = |\eta_c| + \eta_a + i_{\text{corr.}} R$$

is rewritten as

$$I_{\text{corr.}} = \frac{(E_c - E_a) - |\eta_c| - \eta_a}{R} \quad (8.8)$$

although η_a and η_c are functions of the current.

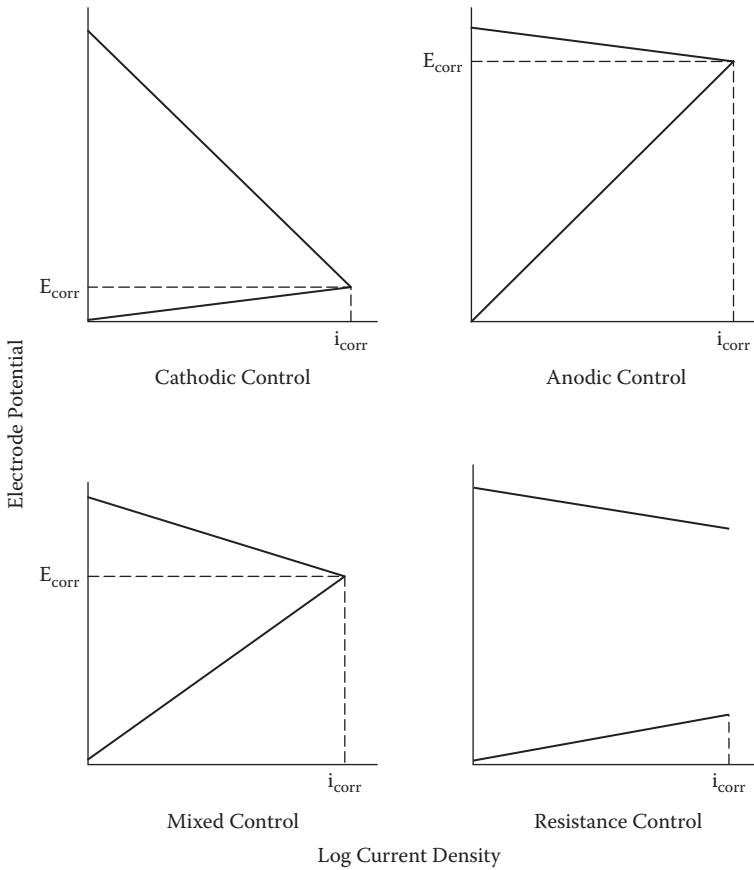
**FIGURE 8.4**

Four types of corrosion controls.

Therefore, a corrosion-resistant coating is achieved by considering five surface treatment methods to decrease i_{corr} on the basis of Equation 8.8. Specifically,

1. Decrease in electromotive force ($E_C - E_a$): EMF control protection
2. Increase in cathodic overpotential: $|\eta_c|$ cathodic control protection
3. Increase in anodic overpotential: η_a anodic control protection
4. Increases in both anodic and cathodic overpotential: η_a and $|\eta_c|$, mixed control protection
5. Increase in resistance of corrosion cell: R resistance control protection.

8.2 EMF Control Protection by Noble Metals

Noble coating metals that provide corrosion protection by means of EMF control include copper, silver, platinum, gold, and their alloys. The standard single potentials of these metals are more noble than those of hydrogen (refer to Table 8.2). Therefore, the oxidizer in corrosion cells formed on these metals in a natural environment, containing no other oxidizers, is dissolved oxygen. Consequently, the electromotive force that causes corrosion is so small that coating with noble metals is an effective means of providing corrosion protection. With the exception of copper, the other members of this group are precious metals and are used primarily for electrical conduction and decorative appearance.

8.2.1 Mechanism of Control Protection

8.2.1.1 Copper Coatings

Although copper is soft, it has many engineering applications in addition to its decorative function. One such application is the corrosion protection of steel. It can be used as an alternative to nickel to prevent fretting and scaling corrosion. Copper can be deposited electrochemically from various aqueous solutions. The properties of the deposit will depend on the chosen bath and the applied procedures. The hardness of the layers varies from 40 to 160 HV.

Because copper is very noble, it causes extreme galvanically induced local corrosion of steel and aluminum substrates. Because of this, extreme care must be taken to produce well-adhering nonporous layers.

The corrosion protection provided by copper coating is twofold, consisting of an original barrier action of the coating layer and a secondary barrier action of corrosion products. The low EMF of copper is responsible for the formation of the original barrier action. The electrochemical reactions in the corrosion cell on copper are as follows:

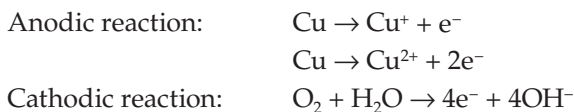

Chloride ions in a natural environment stabilize cuprous ions. Cupric ions are more stable. Because the EMF of corrosion on copper is less than that on iron, the reactivity of a steel surface decreases by coating it with copper.

Over a period of time, corrosion products gradually build up a secondary layer against corrosion. Initially, a cuprous layer is formed, followed by the copper surface covered with basic copper salts. Pollutants in the atmosphere determine the formation of basic copper salts as follows:

Mild atmosphere:	Malachite $\text{CuCO}_3 \cdot \text{Cu(OH)}_2$
SO_x atmosphere:	Brochonite $\text{CuSO}_4 \cdot 3\text{Cu(OH)}_2$
Chloride atmosphere:	Atacamite $\text{CuCl}_2 \cdot 3\text{Cu(OH)}_2$

In most coastal areas, the amount of sulfates in the atmosphere exceeds the amount of chlorides. As a layer of copper salt grows on the surface of the corrosion product layer, the protective ability of the corrosion layer increases. As the exposure time increases, the average corrosion rate of copper gradually decreases. After 20 years, the corrosion rate of copper is reduced to half the value of the first year as a result of the secondary barrier of corrosion products.

The initial corrosion rate of a copper coating depends on atmospheric conditions such as time of wetness, and type and amount of pollutants. Time of wetness is the most important factor affecting the corrosion rate of copper. The corrosion rate of copper usually obeys parabolic law:

$$M^2 = kt$$

where M is the mass increase, k is a constant, and t is the exposure time.

Accordingly, the average corrosion rate decreases with increased exposure time, which means that the surface of the copper is covered with basic salts by degrees and thereafter the corrosion rate approaches a constant value.

Twenty-year exposure tests found the average corrosion rate of copper to be as follows:

- 0.0034 mil/yr in dry rural atmospheres
- 0.143 mil/yr in rural atmospheres
- 0.0476–0.515 mil/yr in industrial atmospheres
- 0.0198–0.0562 mil/yr in marine atmospheres

Until the base metal is exposed, the corrosion process of a copper-coated layer is similar to that of copper plate. Galvanic corrosion of copper-coated steel is induced when the steel substrate is exposed. However, in the case of copper-coated stainless steel, the occurrence of galvanic action depends on the composition of the stainless steel.

In chloride atmospheres, galvanic pitting takes place at the pores in copper layers and galvanic tunneling at cut edges on types 409 and 430 stainless steels; whereas in SO_x atmospheres, uniform corrosion takes place on the copper coating.

Copper coatings are used for both decorative purposes and for corrosion protection from the atmosphere. Copper-coated steels are used as roofs, flashings, leaders, gutters, and architectural trim. Copper undercoat also improves the corrosion resistance of multilayered coatings, specifically in the plating of nickel and chromium.

8.2.1.2 Gold Coatings

Gold electrodeposits are primarily used to coat copper in electronic applications to protect the copper connectors and other copper components from corrosion. It is desirable to obtain the corrosion protection with the minimum thickness of gold because of the cost of the gold. As the thickness of the electrodeposit decreases, there is a tendency for the deposit to provide inadequate coverage of the copper. For this reason it is necessary that there be a means whereby the coverage of the copper can be determined. Such a test using corrosion principles as a guide has been developed. In a 0.1 M NH_4Cl solution, gold serves as the cathode and copper serves as the anode. At a high cathode/anode surface area fraction, the corrosion potential is linearly related to the area fraction of copper exposed, as shown in Figure 8.5. By measuring the corrosion potential of the gold-plated copper in a 0.1 M NH_4Cl solution, the area fraction of copper exposed is determined.

Gold coatings can also be deposited by means of electroless plating. Borohydride or DMAB is used as the reducer with a stable gold cyanide complex. Thin gold coatings can be deposited on plastics by an aerosol method using gold complexes with amines and hydrazine as a reducer. A relatively thick coat can be obtained.

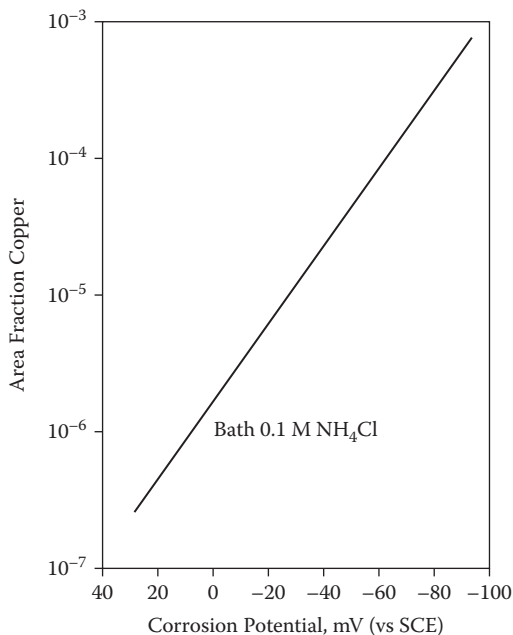

FIGURE 8.5

Data showing that the fractional exposed area of copper in a copper-gold system is linearly related to the corrosion potential at low exposed copper areas.

8.3 Anodic Control Protection by Noble Metals

Coating metals that provide protection by means of anodic control include nickel, chromium, tin, lead, and their alloys.

They protect the substrate metal as a result of their resistance to corrosion insofar as they form a well-adhering and nonporous barrier layer. However, when the coating is damaged, galvanically induced corrosion will lead to severe attack. This corrosion process is extremely fast for coated systems due to the high current density effect as a result of the large ratio between the surface areas and the cathodic outer surface and the anodic effect, as shown in Figure 8.6. To compensate for these defects in the coating, multilayer coating systems have been developed. The corrosion resistance of a single noble layer metal coating results from the original barrier action of the noble metal, the surface of the noble metal being passivated. With the exception of lead, a secondary barrier of corrosion products is formed. Noble metals do not provide cathodic protection for steel substrates because their corrosion potential is more noble than those of iron and steel in a natural environment (see Table 8.1). In multilayer coating systems, a small difference in potential between coating layers results in galvanic action in coating layers.

8.3.1 Mechanisms of Control Protection

8.3.1.1 Nickel Coatings

There are three types of nickel coatings: bright, semibright, and dull bright. The difference between the coatings is in the quantity of sulfur contained in them, as shown:

Nickel Coating	Sulfur Content (%)
Bright nickel deposits	>0.04
Semibright nickel deposits	<0.005
Dull bright nickel deposits	<0.001

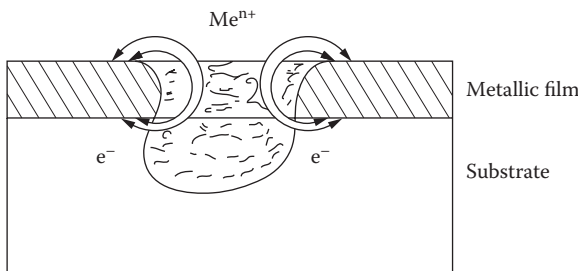

FIGURE 8.6

Dissolution of substrate metal in coating defect.

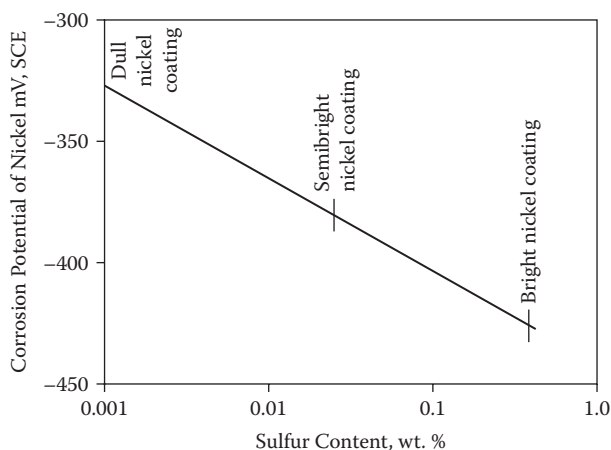

FIGURE 8.7

Effect of sulfur content on corrosion protection of nickel.

The corrosion potentials of the nickel deposits depend on the sulfur content. Figure 8.7 shows the effect of sulfur content on the corrosion potential of a nickel deposit. A single-layer nickel coating must be greater than $30\ \mu\text{m}$ to ensure the absence of defects.

As the sulfur content increases, the corrosion potential of a nickel deposit becomes more negative. A bright nickel coating is less protective than a semibright or dull nickel coating. The difference in the potential of bright nickel and semibright nickel deposits is more than 50 mV.

Use is made of the differences in the potential in the application of multi-layer coatings. The more negative bright nickel deposits are used as sacrificial intermediate layers. When bright nickel is used as an intermediate layer, the corrosion behavior is characterized by sideways diversion. Pitting corrosion is diverted laterally when it reaches the more noble semibright nickel deposit. Thus, the corrosion behavior of bright nickel prolongs the time for pitting penetration to reach the base metal.

The most negative of all nickel deposits is trinickel. In this triplex layer coating system, a coating of trinickel approximately $1\ \mu\text{m}$ thick, containing 0.1 to 0.25% sulfur, is applied between bright nickel and semibright nickel deposits. The high-sulfur nickel layer dissolves preferentially, even when pitting corrosion reaches the surface of the semibright nickel deposit. Because the high-sulfur layer reacts with the bright nickel layer, pitting corrosion does not penetrate the high-sulfur nickel layer in the tunneling form. The application of a high-sulfur nickel strike definitely improves the protective ability of a multilayer nickel coating.

In the duplex nickel coating system, the thickness ratio of semibright nickel deposit to bright nickel deposit is nominally 3:1, and a thickness of 20 to 25

μm is required to provide high corrosion resistance. The properties required for a semibright nickel deposit are as follows:

1. The deposit contains little sulfur.
2. Internal stress must be slight.
3. Surface appearance is semibright and extremely level.

For a trinickel (high-sulfur) strike, the following properties are required:

1. The deposit contains a stable 0.1 to 0.25% sulfur.
2. The deposit provides good adhesion for semibright nickel deposits.

Nickel coatings can be applied by electrodeposition or electrolessly from an aqueous solution without the use of an external applied current.

Depending on the production facilities and the electrolyte composition, electrodeposited nickel can be relatively hard (120 to 400 HV). Despite competition from hard chromium and electroless nickel, electrodeposited nickel is still being used as an engineering coating because of its relatively low price. Some of its properties are:

1. Good general corrosion resistance
2. Good protection from fretting corrosion
3. Good machineability
4. The ability of layers of 50 to 75 μm to prevent scaling at high temperatures
5. Mechanical properties, including the internal stress and hardness, that are variable and can be fixed by selecting the manufacturing parameters
6. Excellent combination with chromium layers
7. A certain porosity
8. A tendency for layer thicknesses below 10 to 20 μm on steel to give corrosion spots due to porosity

The electrodeposition can be either directly on steel or over an intermediate coating of copper. Copper is used as an underlayer to facilitate buffing, because it is softer than steel, and to increase the required coating thickness with a material less expensive than nickel.

The most popular electroless nickel plating process is the one in which hypophosphite is used as the reducer. Autocatalytic nickel ion reduction by hypophosphite takes place in both acid and alkaline solutions. In a stable solution with high coating quality, the deposition rate may be as high as 20 to

25 $\mu\text{m}/\text{h}$. However, a relatively high temperature of 194°F (90°C) is required. Because hydrogen ions are formed in the reduction reaction,

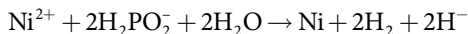

a high buffering capacity of the solution is necessary to ensure a steady-state process. For this reason, acetate, citrate, propionate, glycolate, lactate, or aminoacetate is added to the solutions. These substances, along with buffering, may form complexes with nickel ions. Binding Ni^{2+} ions into a complex is required in alkaline solutions (here, ammonia and pyrophosphate may be added in addition to citrate and aminoacetate). In addition, such binding is desirable in acid solutions because free nickel ions form a compound with the reaction product (phosphate) that precipitates and prevents further use of the solution.

When hypophosphite is used as the reducing agent, phosphorus will be present in the coating. Its amount, in the range of 2 to 15 mass %, depends on pH, buffering capacity, ligands, and other parameters of electroless solutions.

Borohydride and its derivatives can also be used as reducing agents. When borohydride is used in the reduction, temperatures of 140°F to 194°F (60°C to 90°C) are required. The use of dimethylaminoborane (DMAB) enables the deposition of Ni-B coatings with a small amount of boron (0.5 to 1.0 mass % at temperatures in the range of 86°F to 140°F (30°C to 60°C). Both neutral and alkaline solutions may be used.

Depending on exposure conditions, certain minimum coating thicknesses to control porosity are recommended for the coating to maintain its appearance and have a satisfactory life:

Exposure	Minimum Coating Thickness
Indoor exposures	0.3–0.5 / 0.008–0.013 mm
Outdoor exposures	0.5–1.5 / 0.013–0.04 mm
Chemical industry	1–10 / 0.025–0.25 mm

For applications near the seacoast, thicknesses in the area of 1.5 mil (0.04 mm) should be considered. This also applies to automobile bumpers and applications in industrial atmospheres.

Nickel is sensitive to attack by industrial atmospheres and forms a film of basic nickel sulfate that causes the surface to “fog” or lose its brightness. To overcome this fogging, a thin coating of chromium (0.01 to 0.03 mil/0.003 to 0.007 mm) is electrodeposited over the nickel. This finish is applied to all materials for which continued brightness is desired.

Single-layer coatings of nickel exhibit less corrosion resistance than multilayer coatings due to their discontinuities. The electroless plating process produces a coating with fewer discontinuous deposits. Therefore, the single

layer deposited by electroless plating provides more corrosion resistance than does an electroplated single layer.

Most electroless plated nickel deposits contain phosphorus, which enhances corrosion resistance. In the same manner, an electroplated nickel deposit containing phosphorus will also be more protective.

Satin finish nickel coating. A satin-finish nickel coating consists of nonconductive materials such as aluminum oxide, kaolin, and quartz that are co-deposited with chromium on the nickel deposit. Some particles are exposed on the surface of the chromium deposit, so the deposit has a rough surface. Because the reflectance of the deposit is decreased to less than half of that of a level surface, the surface appearance looks like satin.

A satin-finish nickel coating provides good corrosion resistance due to the discontinuity of the chromium topcoat.

Nickel-iron alloy coating. To reduce production costs of bright nickel, the nickel-iron alloy coating was developed. The nickel-iron alloy deposits full brightness, high leveling, and excellent ductility, and exhibits good reception for chromium.

This coating has the disadvantage of forming red rust when immersed in water; consequently, nickel-iron alloy coating is suitable for use in mild atmospheres only. Typical applications include kitchenware and tubular furniture.

8.3.1.2 Chromium Coatings

In northern parts of the United States immediately after World War II, it was not unusual for chromium-plated bumpers on the most expensive cars to show severe signs of rust within a few months of winter exposure. This was partially the result of trying to extend the short supply of strategic metals by economizing on the amount used. However, the more basic reason was the lack of sufficient knowledge of the corrosion process to control the attack by the atmosphere. Consequently, an aggressive industrial program was undertaken to obtain a better understanding of the corrosion process and ways to control it.

Chromium-plated parts on automobiles consist of steel substrates with an intermediate layer of nickel or, in some cases, layered deposits of copper and nickel. The thin chromium deposit provides a bright appearance and stain-free surface, while the nickel layer provides corrosion protection to the steel substrate. With this system, it is essential that the nickel cover the steel substrate completely because the iron will be the anode and nickel the cathode. Any breaks or pores in the coating will result in the corrosion shown in Figure 8.8. This figure illustrates the reason for the corrosion of chrome trim on automobiles after World War II.

The corrosion problem was made worse by the fact that addition agents used in the plating bath resulted in a bright deposit. Bright deposits contain sulfur, which makes the nickel more active from a corrosion stand-

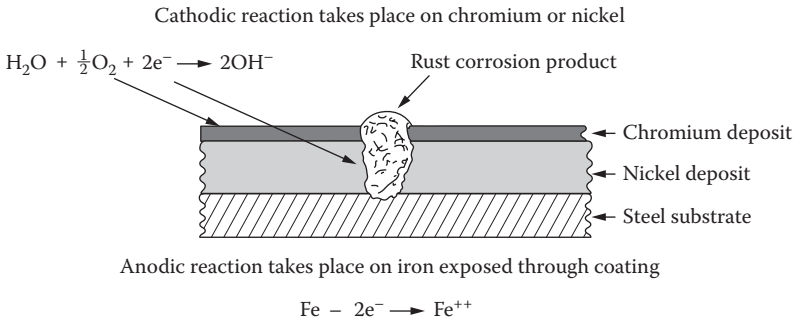
**FIGURE 8.8**

Corrosion of steel at breaks in a nickel-chromium coating when exposed to the atmosphere.

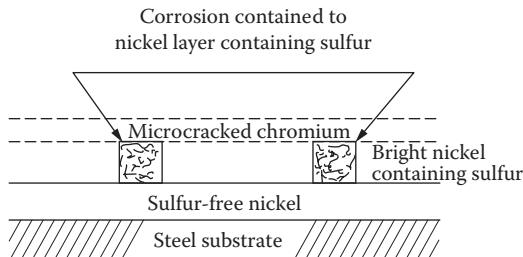
**FIGURE 8.9**

Duplex nickel electrode deposit to prevent corrosion of steel substrate.

point, which is discouraging. However, it occurred to investigators that this apparent disadvantage of bright nickel could be put to good use.

To solve this problem, a duplex nickel coating was developed, as shown in Figure 8.9. An initial layer of sulfur-free nickel is applied to the steel surface, followed by an inner layer of bright nickel containing sulfur, with an outer layer of microcracked chromium.

Any corrosion that takes place is limited to the bright nickel layer containing sulfur. The corrosion spreads laterally between the chromium and sulfur-free nickel deposits because the outer members of the “sandwich” (i.e., chromium and sulfur-free nickel) are cathodic to the sulfur-containing nickel.

A potential problem that could result from this system of corrosion control would be the undermining of the chromium and the possibility that the brittle chromium deposits could flake off the surface. This potential problem was prevented by the development of a microcracked or microporous chromium coating. These coatings contain microcracks or micropores that do not detract from the bright appearance of the chromium. They are formed very

uniformly over the exterior of the plated material and serve to distribute the corrosion process over the entire surface. The result has been to extend the life of chromium-plated steel exposed to outdoor conditions.

Microcracked chromium coatings are produced by first depositing a high-stress nickel strike on a sulfur-free nickel layer and then a decorative chromium deposit. The uniform crack network results from the interaction of the thin chromium layer and the high-stress nickel deposit. The result is a mirror surface as well as a decorative chromium coating.

Microporous chromium coatings are produced by first electroplating a bright nickel layer containing suspended nonconductive fine particles. Over this, a chromium layer is deposited that results in a mirror finish. As the chromium thickness increases, the number of pores decreases. For a chromium deposit of 0.25-m thickness, a porosity of more than 10,000 pores/cm² are required. A porosity of 40,000 pores/cm² provides the best corrosion resistance.

Hard (engineering) chromium layers are also deposited directly on a variety of metals. The purpose of applying these layers is to obtain a wear-resistant surface with a high hardness or to restore the original dimensions to a work piece. In addition, the excellent corrosion resistance resulting from these layers makes them suitable for outdoor applications.

Thick chromium deposits have high residual internal stress and may be brittle due to the electrodeposition process, in which hydrogen can be incorporated in the deposited layer. Cracks result during plating when the stress exceeds the tensile strength of the chromium. As the plating continues, some of the cracks are filled. This led to the development of controlled cracking patterns, which produce wettable surfaces that can spread oil, which is important for engine cylinders, liners, etc.

Some of the properties of the engineering chromium layers are:

- Excellent corrosion resistance
- Wear resistance
- Hardness up to 950 HV
- Controlled porosity is possible

8.3.1.3 Tin Coatings (Tinplate)

Tinplate is produced mainly by the electroplating process. Alkaline and acid baths are used in the production line. The acid baths are classified as either ferrosan or halogen baths.

A thermal treatment above the melting point of tin follows electrolytic deposition. The intermetallic compound FeSn₂ forms at the interface between the iron and tin during this thermal processing. The corrosion behavior of the tinplate is determined by the quality of the FeSn₂ formed, particularly when the amount of the free tin is small. The best-performing tinplate is that in which the FeSn₂ uniformly covers the steel so that the area of iron exposed

is very small in case the tin should dissolve. Good coverage requires good and uniform nucleation of FeSn_2 . Many nuclei form when electrodeposition of tin is carried out from the alkaline stannate bath.

Compared to either iron or tin, FeSn_2 is chemically inert in all but the strongest oxidizing environments.

Most of the tinplate (tin coating on steel) produced is used for manufacturing food containers (tin cans). The nontoxic nature of tin salts makes tin an ideal material for the handling of foods and beverages.

An inspection of the galvanic series will indicate that tin is more noble than steel and, consequently, the steel will corrode at the base of the pores. On the outside of the tinned container, this is what happens — the tin is cathodic to the steel. However, on the inside of the container, there is a reversal of polarity because of the complexing of the stannous ions by many food products. This greatly reduces the activity of the stannous ions, resulting in a change in the potential of tin in the active direction.

This change in polarity is absolutely necessary because most tin coatings are thin and therefore porous. To avoid perforation of the can, the tin must act as a sacrificial coating. Figure 8.10 illustrates this reversal of activity between the outside and inside of the can.

The environment inside a hermetically sealed can varies depending upon the contents, which include general foods, beverages, oils, aerosol products, liquid gases, etc. For example, pH values vary for different contents:

Contents	pH Range
Acidic beverage	2.4–4.5
Beer and wine	3.5–4.5
Meat, fish, marine products, and vegetables	4.1–7.4
Fruit juices, fruit products	3.1–4.3
Nonfood products	1.2–1.5

The interior of cans is subject to general corrosion, localized corrosion, and discoloring. The coating system for tinplate consists of tin oxide, metallic tin, and alloy. The dissolution of the tin layer in acid fruit products is caused by acids such as citric acid. In acid fruit products, the potential reversal occurs between the tin layer and the steel substrate, as shown in Figure 8.11. The potential reversal of a tin layer for steel substrate occurs at a $\text{pH} < 3.8$ in a citric acid solution. This phenomenon results from the potential shift of the tin layer to a more negative direction. Namely, the activity of the stannous ion, Sn^{2+} , is reduced by the formation of soluble tin complexes, and thereby the corrosion potential of the tin layer becomes more negative than that of steel. Thus, the tin layer acts as a sacrificial anode for steel so that the thickness and density of the pores in the tin layer are important factors

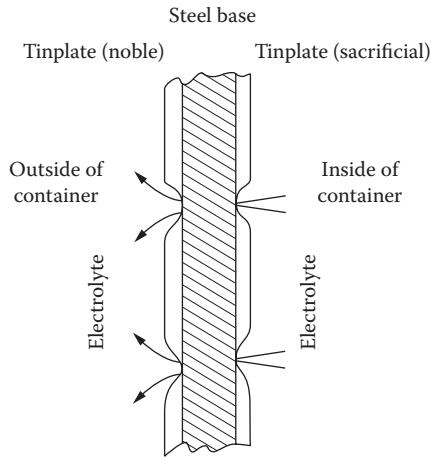

FIGURE 8.10
Tin acting as both a noble and sacrificial coating.

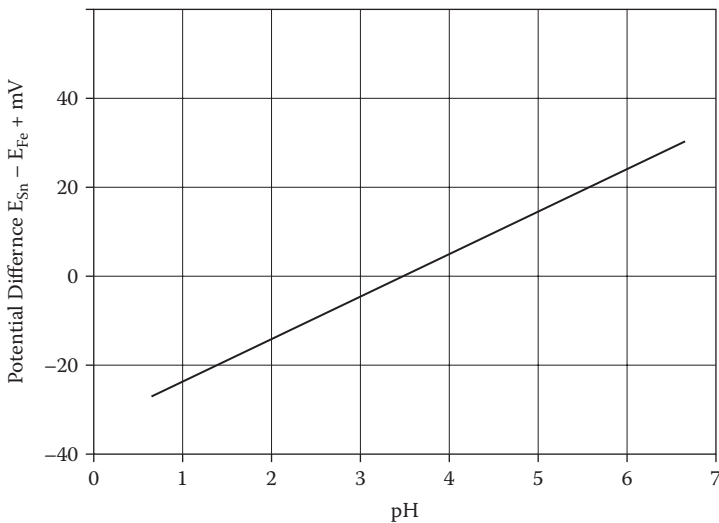

FIGURE 8.11
Potential reversal in tinplate.

affecting the service life of the coating. A thicker tin layer prolongs the service life of a tin can. The function of the alloy layer (FeSn) is to reduce the active area of steel by covering it because it is inert in acid fruit products. When some parts of the steel substrate are exposed, the corrosion of the tin layer is accelerated by galvanic coupling with the steel. The corrosion potential of the alloy layer is between that of the tin layer and that of the steel. A less defective layer exhibits a potential closer to that of the tin layer.

Therefore, covering with the alloy layer is important in decreasing the dissolution of the tin layer.

In carbonated beverages, the potential reversal does not take place; therefore, the steel dissolves preferentially at the defects in the tin layer. Under such conditions, pitting corrosion sometimes results in perforation. Consequently, except for fruit cans, almost all tinfoil cans are lacquered.

When tinfoil is to be used for structural purposes such as roofs, an alloy of 12 to 25 parts of tin to 88 to 75 parts of lead is frequently used. This is called terneplate. It is less expensive and more resistant to weather than a pure tin coating. Terneplate is used for the fuel tanks of automobiles and also in the manufacture of fuel lines, brake lines, and radiators in automobiles.

8.3.1.4 Lead Coatings

Coatings of lead and its alloy (5 to 10% Sn) protect the steel substrate, especially in industrial areas having an SO_x atmosphere. At the time of initial exposure, pitting occurs on the lead surface; however, the pits are self healed and then the lead surface is protected by the formation of insoluble lead sulfate. Little protection is provided by these coatings when in contact with soil.

Lead coatings are usually applied by either hot dipping or by electrodeposition. When the coating is to be applied by hot dipping, a small percentage of tin is added to improve the adhesion to the steel plate. If 25% or more of tin is added, the resultant coating is called terneplate.

Caution: Do not use lead coatings if they will come into contact with drinking water or food products. Lead salts can be formed that are poisonous.

Terneplate. Terneplate is a tin-lead alloy coated sheet steel, and is produced either by hot dipping or electrodeposition. The hot dipping process with a chloride flux is used to produce most terneplates. The coating layer, whose electrode potential is more noble than that of the steel substrate, contains 8 to 16% tin. Because the electrode potential of the coating layer is more noble than the steel substrate, it is necessary to build a uniform and dense alloy layer (FeSn_2) in order to form a pinhole-free deposit.

Terneplate exhibits excellent corrosion resistance, especially under wet conditions, excellent weldability and formability, with only small amounts of corrosion products forming on the surface. A thin nickel deposit can be applied as an undercoat for the terne layer. Nickel reacts rapidly with the tin-lead alloy to form a nickel-tin alloy layer. This alloy layer provides good corrosion resistance and inhibits localized corrosion. The main application for terneplate is in the production of fuel tanks for automobiles.

8.4 Cathodic Control by Sacrificial Metal Coatings

Non-noble metals protect the substrate by means of cathodic control. Cathodic overpotential of the surface is increased by coating, which makes the corrosion potential more negative than that of the substrate. The coating metals used for cathodic control protection are zinc, aluminum, manganese, and cadmium, and their alloys, of which the electrode potentials are more negative than those of iron or steel. Consequently, the coating layers of these metals act as sacrificial anodes for iron and steel substrates when the substrates are exposed to the atmosphere. The coating layer provides cathodic protection for the substrate by galvanic action. These metals are called sacrificial metals.

Sacrificial metal coatings protect iron and steel by two or three protective abilities:

1. Original barrier action of coating metal
2. Secondary barrier action of corrosion product layer
3. Galvanic action of coating layer

The surface oxide film and the electrochemical properties based on the metallography of the coating metal provide the original barrier action.

An air-formed film of Al_2O_3 , approximately 25-Å thick, forms on aluminum. This film is chemically inert, and its rapid formation of oxide film by a self-healing ability leads to satisfactory performance in natural environments.

Zinc, however, does not produce a surface oxide film that is as effective a barrier as the oxide on aluminum. The original barriers of zinc and zinc alloy coatings result from the electrochemical properties based on the structure of the coating layer.

Nonuniformity of the surface condition generally induces the formation of a corrosion cell. Such nonuniformity results from defects in the surface oxide film, localized distribution of elements, and the difference in crystal face or phase. These surface nonuniformities cause the potential difference between portions of the surface, thereby promoting the formation of a corrosion cell.

Many corrosion cells are formed on the surface, accelerating the corrosion rate, as a sacrificial metal and its alloy-coated materials are exposed in the natural atmosphere. During this time, corrosion products are gradually formed and converted to a stable layer after a few months of exposure. Typical corrosion products formed are shown in Table 8.3. Once the stable layer has formed, the corrosion rate becomes constant. This secondary barrier of corrosion protection regenerates continuously over a long period of time. In most cases, the service life of a sacrificial metal coating depends on the secondary barrier action of the corrosion product layer.

TABLE 8.3

Corrosion Products Formed on Various Sacrificial Metal Coatings

Metal	Corrosion Product
Al	Al_2O_3 , $\beta\text{-Al}_2\text{O}_3$, H_2O , $\propto\text{AlOOH}$, $\text{Al}(\text{OH})_3$, amorphous Al_2O_3
Zn	ZnO , $\text{Zn}(\text{OH})_2$, $2\text{ZnCO}_3 \cdot 3\text{Zn}(\text{OH})_2$, $\text{ZnSO}_4 \cdot 4\text{Zn}(\text{OH})_2$, $\text{ZnCl}_2 \cdot 4\text{Zn}(\text{OH})_2$, $\text{ZnCl}_2 \cdot 6\text{Zn}(\text{OH})_2$
Mn	$\gamma\text{-Mn}_2\text{O}_3$, MnCO_3 , $\gamma\text{-MnOOH}$
Cd	CdO , CdOH_2 , $2\text{CdCO}_3 \cdot 3\text{Cd}(\text{OH})_2$

Sacrificial metal coatings are characterized by their galvanic action. Exposure of the base metal, as a result of mechanical damage, polarizes the base metal cathodically to the corrosion potential of the coating layer, as shown in Figure 8.12, so that little corrosion takes place on the exposed base metal. A galvanic couple is formed between the exposed part of the base metal and the surrounding coating metal. Because sacrificial metals are more negative in electrochemical potential than iron or steel, a sacrificial metal acts as an anode and the exposed base metal behaves as a cathode.

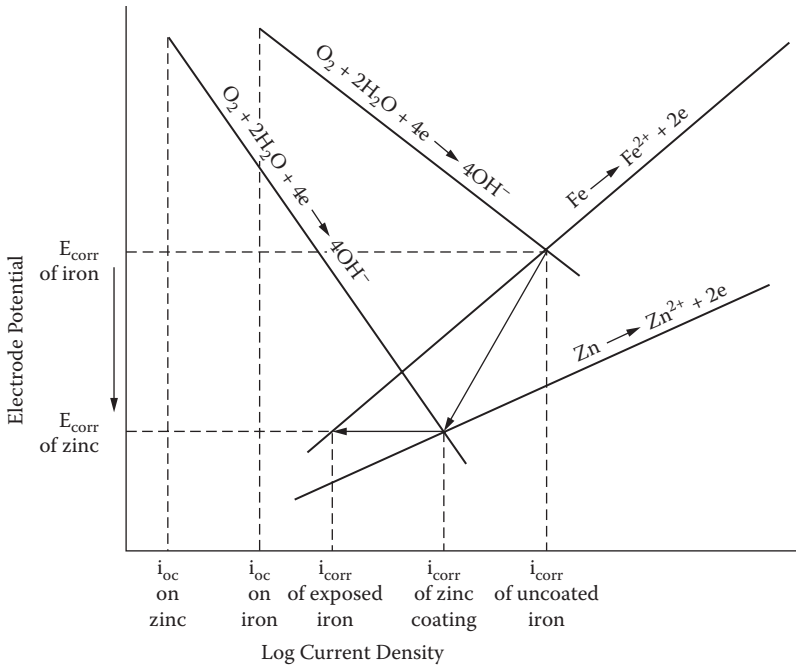
**FIGURE 8.12**

Cathodic control protection.

Table 8.4 shows the corrosion potentials of sacrificial metals and steel in a 3% NaCl solution. Consequently, the dissolution of the coating layer around the defect is accelerated and the exposed part of the base metal is protected against corrosion. Figure 8.13 shows a schematic illustration of the galvanic action of a sacrificial metal coating.

The loss of metal coating resulting from corrosion determines the service life of the coating. The degree of loss depends on the time of wetness on the metal surface and the type of concentration of pollutants in the atmosphere. Table 8.5 shows the average corrosion losses of zinc, aluminum, and 55% Al-Zn coatings in various locations and atmospheres. The losses were calculated from the mean values of time of wetness and the average corrosion rate during wet duration. The time of wetness of walls is 40% that of roofs. Coating metals and coating thicknesses can be decided from Table 8.5 because

TABLE 8.4
Corrosion Potentials of Sacrificial Metals in 3% NaCl Solution

Metal	Corrosion Potential (V, SCE)
Mn	-1.50
Zn	-1.03
Al	-0.79
Cd	-0.70
Steel	-0.61

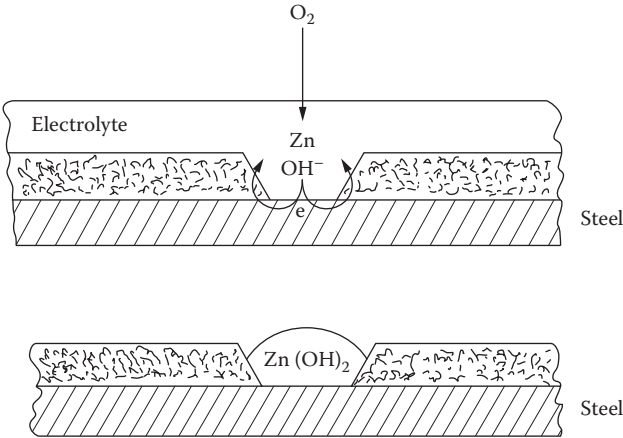

FIGURE 8.13
Schematic illustration of galvanic action of sacrificial metal coating.

the corrosion losses of zinc, aluminum, and Al-Zn alloy are proportional to exposure time.

As Table 8.5 reveals, a G90 sheet, which has a 1-mil zinc coating, cannot be used for a roof having a durability of 10 years in any atmosphere except in a rural area. Were this sheet to be used in an urban, marine, or industrial atmosphere, it would have to be painted for protection.

Aluminum and 55% Al-Zn alloy provide galvanic protection for steel substrates. In rural and industrial atmospheres, an aluminum coating does not act as a sacrificial anode. However, in a chloride atmosphere such as a marine area, it does act as a sacrificial anode.

The choice as to which sacrificial metal coating to use will be based on the environment to which it will be exposed and the service life required. The service life required will also determine the coating thickness to be applied, which will, in turn, influence the coating process to be used. Sacrificial metal coatings have been used successfully for roofs, walls, ducts, shutters, doors, and window frames in the housing industry, and on structural materials such as transmission towers, structural members of bridges, antennae, chimney structures, grandstands, steel frames, high-strength steel bolts, guardrails, corrugated steel pipe, stadium seats, bridge I-beams, footway bridges, road bridges, and fencing.

TABLE 8.5

Average Corrosion Losses of Sacrificial Metal Coatings for 10 Years

Location	Atmosphere	Average Corrosion Loss (mil/10 yr) ^a					
		Zinc		55% AlZn		Aluminum	
		Roof	Wall	Roof	Wall	Roof	Wall
Inland	Rural	0.42	0.17	0.15	0.06	0.06	0.02
	Urban	1.48	0.59				
	Industrial	1.40	0.56	0.25	0.06	0.06	0.02
	Severe industrial	1.59	0.64				
Inland shore of lake or marsh	Rural	0.59	0.24	0.20	0.08	0.07	0.03
	Urban	1.97	0.79				
	Industrial	1.40	0.56	0.20	0.08	0.08	0.03
	Severe industrial	2.12	0.85				
Coast	Rural	0.74	0.23	0.25	0.10	0.08	0.04
	Urban	2.47	0.99				
	Industrial	1.75	0.70	0.25	0.10	0.10	0.04
	Severe industrial	2.65	1.06				
Seashore	Severe industrial	2.06	0.82	0.46	0.18	0.19	0.07

^a 1 mil = 25.4 μm.

8.4.1 Mechanism of Control Protection

8.4.1.1 Zinc Coatings

Approximately half of the world's production of zinc is used to protect steel from rust. Zinc coatings are probably the most important type of metallic coating for corrosion protection of steel. The reasons for the wide application include:

1. Prices are relatively low.
2. Due to large reserves, an ample supply of zinc is available.
3. There is great flexibility in application procedures, resulting in many different qualities with well-controlled layer thickness.
4. Steel provides good cathodic protection.
5. Many special alloy systems have been developed with improved corrosion-protection properties.

The ability to select a particular alloy or to specify a particular coating thickness depends on the type of coating process used. Zinc coatings can be applied in many ways. The six most commonly used procedures follow.

Hot dipping. This is a process in which cleaned steel is immersed in molten zinc or zinc alloy, and a reaction takes place to form a metallurgically bonded coating.

The coating is integral with the steel because the formation process produces zinc-iron alloy layers overcoated with zinc. Continuity and uniformity are good because any discontinuities are readily visible as "black spots."

Coating thicknesses can be varied from approximately 50 to 125 μm on tube and products. Thicker coatings up to 250 μm can be obtained by grit blasting before galvanizing. Steel and wire normally receive thicknesses of 10 to 30 μm .

Conventional coatings that are applied to finished articles are not formable. The alloy layer is abrasion resistant but brittle on bending. Special coatings with little or no alloy layer are readily formed (e.g., on sheet) and resistance welded.

A chromatic conversion coating over the zinc coating prevents wet storage stains while phosphate coatings provide a good base (on a new sheet) for paints. Weathered coatings are often painted after 10 to 30 years for longer service.

Hot dip galvanizing is the most important zinc coating process. All mild steel and cast iron can be coated by this process. The thickness and structure of the coating will depend on the alloying elements. Approximately half of the steel that is coated is in the form of sheet, approximately one quarter is fabricated work while the remainder is tube or wire. Metallurgically, the processes used for tubes and fabricated work are similar, while the process used for sheet has small additions to the zinc that reduce the quantity of iron-zinc in the coating, which provides flexibility.

Zinc electroplating. This process is sometimes mistakenly referred to as electrogalvanizing. In this process, zinc salt solutions are used in the electrolytic deposition of a layer of zinc on a cleaned steel surface.

The process provides good adhesion, comparable with other electroplated coatings. The coating is uniform within the limitations of the “throwing power” of the bath. Pores are not a problem as exposed steel is protected by the adjacent zinc.

Coating thicknesses can be varied at will but are usually 2.5 to 15 μm . Thicker layers are possible but are not usually economical.

Electroplated steel has excellent formability and can be spot welded. Small components are usually finished before being plated.

Chromate conversion coatings are used to prevent wet storage stain while phosphate conversion coatings are used as a base for paint.

The process is normally used for simple, fairly small components. It is suitable for barrel plating or for continuous sheet and wire. No heating is used in this process, except for hydrogen embrittlement relief on high-strength steels.

Electroplated zinc is very ductile and consequently this process is widely used for the continuous plating of strip or wire, where severe deformation may be required.

The coating on steel from this process gives a bright and smooth finish. It is used for decorative effect to protect delicate objects where rough or uneven finishes cannot be tolerated (e.g., instrument parts). It is also used for articles that cannot withstand the temperatures required in other coating processes.

It was previously mentioned that the term “electrogalvanizing” is sometimes used to describe this process. This is misleading because the chief characteristic of galvanizing is the formation of a metallurgical bond at the zinc-iron interface. This does not occur in electroplating.

Mechanical coating. This process involves agitating suitably prepared parts to be coated with a mixture of nonmetallic impactors (e.g., glass beads), zinc powder, a chemical promoter, and water. All types of steel can be coated. However, this process is less suitable for parts heavier than 0.5 pound (250 g) because the tumbling process reduces coating thicknesses at the edges.

The adhesion is good compared to electroplated coatings. Thicknesses can be varied from 5 μm to more than 70 μm . However, the coating is not alloyed with steel, nor does it have the hard abrasion resistance iron-zinc alloy layers of galvanized or sherardized coatings. Conversion coatings can be applied.

Sherardizing. The articles to be coated are tumbled in a barrel containing zinc dust at a temperature just below the melting point of zinc, usually around 716°F (380°C). In the case of spring steels, the temperature is somewhat lower. By means of a different process, the zinc bonds to the steel, forming a hard, even coating of zinc-iron compounds. The coating is dull gray in color and can readily be painted if necessary.

The finish is continuous and very uniform, even on threaded and irregular parts. This is a very useful finish for nuts and bolts, which, with proper allowance for the thickness of coats, can be sherardized after manufacture and used without retapping the threads.

The thickness of the coating can be controlled. Usually, a thickness of 30 μm is used for outdoor applications while 15 μm is used for indoor applications.

Thermally sprayed coatings. In this process, droplets of semimolten zinc are sprayed from a special gun that is fed with either wire or powder onto a grit-blasted surface. The semimolten droplets coalesce with some zinc oxide present at each interface between droplets. Electrical continuity is maintained both throughout the coating and with the iron substrate so that full cathodic protection can be obtained because the zinc oxide forms only a small percentage of the coating.

The sprayed coating contains voids (typically 10 to 20% by volume) between coalesced particles. These voids have little effect on the corrosion protection because they soon fill up with zinc corrosion products and are thereafter impermeable. However, the use of a sealer to fill the voids improves appearance in service and adds to life expectancy but, more importantly, it provides a better surface for subsequent application of paint.

There are no size or shape limitations regarding the use of this process.

Zinc Dust Painting. Zinc dust paints can be used alone for protection or as a primer followed by conventional topcoats.

8.4.1.2 Corrosion of Zinc Coatings

In general, zinc coatings corrode in a similar manner as solid zinc. However, there are some differences. For example, the iron-zinc alloy present in most galvanized coatings has a higher corrosion resistance than solid zinc in neutral and acid solutions. At points where the zinc coating is defective, the bare steel is cathodically protected under most conditions.

The corrosion of zinc coatings in air is an approximate straight-line relationship between weight loss and time. Because the protective film on zinc increases with time in rural and marine atmospheres of some types, under these conditions the life of the zinc may increase more than in proportion to thickness. However, this does not always happen.

Zinc coatings are used primarily to protect ferrous parts against atmospheric corrosion. These coatings have good resistance to abrasion by solid pollutants in the atmosphere. General points to consider include:

1. Corrosion increases with time of wetness.
2. The corrosion rate increases with an increase in the amount of sulfur compounds in the atmosphere. Chlorides and nitrogen oxides usually have a lesser effect but are often very significant in combination with sulfates.

Zinc coatings resist atmospheric corrosion by forming protective films consisting of basic salts, notably carbonate. The most widely accepted formula is $3\text{Zn}(\text{OH})_2 \cdot 2\text{ZnCO}_3$. Environmental conditions that prevent the formation of such films, or conditions that lead to the formation of soluble films, may cause rapid attack on the zinc.

The duration and frequency of moisture contact is one such factor. Another factor is the rate of drying because a thin film of moisture with high oxygen concentration promotes reaction. For normal exposure conditions, the films dry quite rapidly. It is only in sheltered areas that drying times are slow, so that the attack on zinc is accelerated significantly.

The effect of atmospheric humidity on the corrosion of zinc is related to the conditions that may cause condensation of moisture on the metal surface, and to the frequency and duration of the moisture contact. If the air temperature drops below the dew point, moisture will deposit. The thickness of the piece, its surface roughness, and its cleanliness will also influence the amount of dew deposited. Lowering the temperature of a metal surface below the air temperature in a humid atmosphere will cause moisture to condense onto the metal. If the water evaporates quickly, corrosion is usually not severe and a protective film is formed on the surface. If water from rain or snow remains in contact with zinc when access to air is restricted and the humidity is high, the resulting corrosion can appear to be severe (wet storage stain, known as "white rust") because the formation of a protective basic zinc carbonate is prevented.

In areas having atmospheric pollutants, particularly sulfur oxides and other acid-forming pollutants, time of wetness becomes of secondary importance. These pollutants can also make rain more acidic. However, in less corrosive areas, time of wetness assumes a greater proportional significance.

In the atmospheric corrosion of zinc, the most important atmospheric contaminant to consider is sulfur dioxide (SO_2). At relative humidities of about 70% or above, it usually controls the corrosion rate.

Sulfur oxides and other corrosive species react with the zinc coating in two ways: (1) dry deposition and (2) wet deposition. SO_2 can deposit on the dry surface of galvanized steel panels until a monolayer of SO_2 is formed. In either case, the SO_2 that deposits on the surface of the zinc forms a sulfurous or other strong acid, which reacts with the film of zinc oxide, hydroxide, or basic carbonate to form zinc sulfate. The conversion of SO_2 to sulfur-based acids may be catalyzed by nitrogen compounds in the air (i.e., NO_x compounds). This factor may affect corrosion rates in practice. The acids partially destroy the film of corrosion products, which will then reform from the underlying metal, thereby causing continuous corrosion by an amount equivalent to the film dissolved, and hence the amount of SO_2 absorbed.

Chlorine compounds have less effect than sulfur compounds in determining the corrosion rate of zinc. Chloride is most harmful when combined with acid due to sulfur gases. This is prevalent on the coast in highly industrial areas.

Atmospheric chlorides will lead to the corrosion of zinc, but to a lesser degree than the corrosion of steel, except in brackish water and flowing seawater. Any salt deposit should be removed by washing. The salt content of the atmosphere will usually decrease rapidly inland further away from the coast, but the change is more gradual and erratic because chloride is not the primary pollutant affecting zinc corrosion. Chloride is most harmful when combined with acidity resulting from sulfur gases.

Other pollutants also have an effect on the corrosion of galvanized surfaces. Deposits of soot or dust can be detrimental because they have the potential to increase the risk of condensation onto the surface and hold more water in position. This is prevalent on upward-facing surfaces. Soot (carbon) absorbs large quantities of sulfur, which are released by rainwater.

In rural areas, overmanuring of agricultural land tends to increase the ammonia content of the air. The presence of normal atmospheric quantities of ammonia does not accelerate the corrosion of zinc, and petrochemical plants where ammonium salts are present show no accelerated attack on galvanized steel. However, ammonia will react with atmospheric sulfur dioxides to produce ammonium sulfate, which accelerates paint film corrosion as well as zinc corrosion. When ammonium reacts with NO_x^- compounds in the atmosphere, ammonium nitrite and nitrate are produced. Both compounds increase the rate of zinc corrosion, but to a lesser extent than SO_2 or SO_3 .

Because of the Mears effect (wire corrodes faster per unit of area than more massive materials), galvanized wire corrodes some 10 to 80% faster than galvanized sheet. However, the life of rope made from galvanized steel wires is greater than the life of the individual wire. This is explained by the fact that the parts of the wire that lie on the outside are corroded more rapidly and, when the zinc film is penetrated in those regions, the uncorroded zinc inside the rope provides cathodic protection for the outer regions.

8.4.1.3 Zinc-5% Aluminum Hot Dip Coatings

This zinc alloy coating is known as Galfan. Galfan coatings have a corrosion resistance up to three times that of galvanized steel. The main difference between these two coatings lies in the degree of cathodic protection they afford. This increase in corrosion protection is evident in both a relatively mild urban-industrial atmosphere and in a marine atmosphere, as can be seen in Table 8.6. The latter is particularly significant because, unlike galvanizing, the corrosion rate appears to slow down after about 4 years, and conventional galvanized steel would show rust after 5 years (Figure 8.14). The slower rate of corrosion also means that the zinc-5% aluminum coatings provide full cathodic protection to cut edges over a longer period of time (see Table 8.7).

Because Galfan can be formed with much smaller cracks than can be obtained in conventional galvanized coatings, it provides excellent protection at panel bulges. This reduced cracking means that less zinc is exposed to

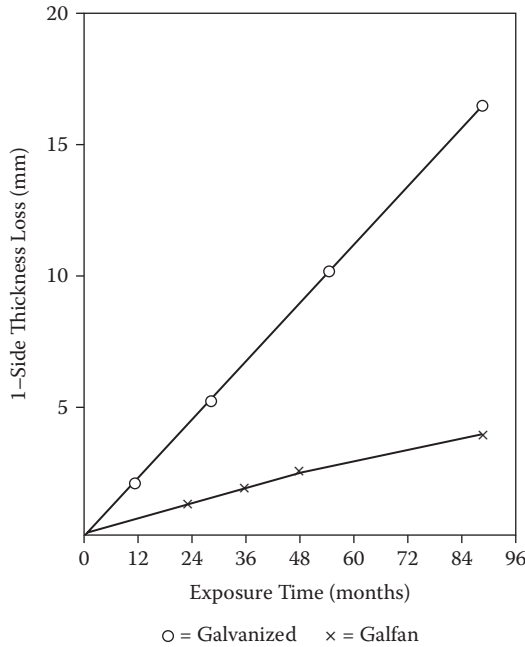

FIGURE 8.14 Seven-year exposure of Galfan and galvanized steel in a severe marine atmosphere.

TABLE 8.6
Five-Year Outdoor Exposure Results of Galfan Coating

Atmosphere	Thickness Loss (μm)		Ratio of Improvement
	Galvanized	Galfan	
Industrial	15.0	5.2	2.9
Severe marine	>20.0	9.5	>2.1
Marine	12.5	7.5	1.7
Rural	10.5	3.0	3.5

Structure of the corrosion cell.

the environment, which increases the relative performance factor compared with galvanized steel.

8.4.1.4 Zinc-55% Aluminum Hot Dip Coatings

These coatings are known as Galvalume and consist of zinc-55% aluminum-1.5% silicon. This alloy is sold under tradenames as Zaluite, Aluzene, Algalva, Algafort, Aluzinc, and Zinalume. Galvalume exhibits superior

TABLE 8.7

Comparison of Cathodic Protection for Galfan and Galvanized Coatings

Environment	Amount (mm) of Bare Edges Exposed after 3 Years (coating recession from edge)	
	Galvanized	Galfan
Severe marine	1.6	0.1
Marine	0.5	0.06
Industrial	0.5	0.05
Rural	0.1	0

corrosion resistance over galvanized coatings in rural, industrial, marine, and severe marine environments. However, this alloy has limited cathodic protection and less resistance to alkaline conditions, and is subject to weathering discoloration and wet storage staining. The latter two disadvantages can be overcome by chromate passivation, which also improves its atmospheric corrosion resistance.

Initially, a high corrosion loss is observed for Galvalume sheet as the zinc-rich portion of the coating corrodes and provides sacrificial protection at cut edges. This takes place in all environments, whereas aluminum provides adequate galvanic protection only in marine chloride environments. After approximately 3 years, the corrosion-time curves take on a more gradual slope, reflecting a change from active, zinc-like behavior to passive, aluminum-like behavior as the interdentric regions fill with corrosion products. It has been predicted that Galvalume sheets should outlast galvanized sheets of equivalent thickness by at least two to four times over a wide range of environments. Figure 8.15 compares the performance of galvanized sheet and Galvalume sheet.

Galvalume sheets provide excellent cut-edge protection in very aggressive conditions, where the surface does not remain too passive. However, it does not offer as good a protection on the thicker sheets in mild rural conditions, where zinc-5% aluminum coatings provide good general corrosion resistance and when sheared edges are exposed or localized damage to the coating occurs during fabrication or service, the galvanic protection is retained for a longer period.

8.4.1.5 Zinc-15% Aluminum Thermal Spray

Zinc-15% aluminum coatings are available as thermally sprayed coatings. These coatings have a two-phase structure consisting of a zinc-rich and an aluminum-rich phase. The oxidation products formed are encapsulated in the porous layer formed by the latter and do not build up a continuous

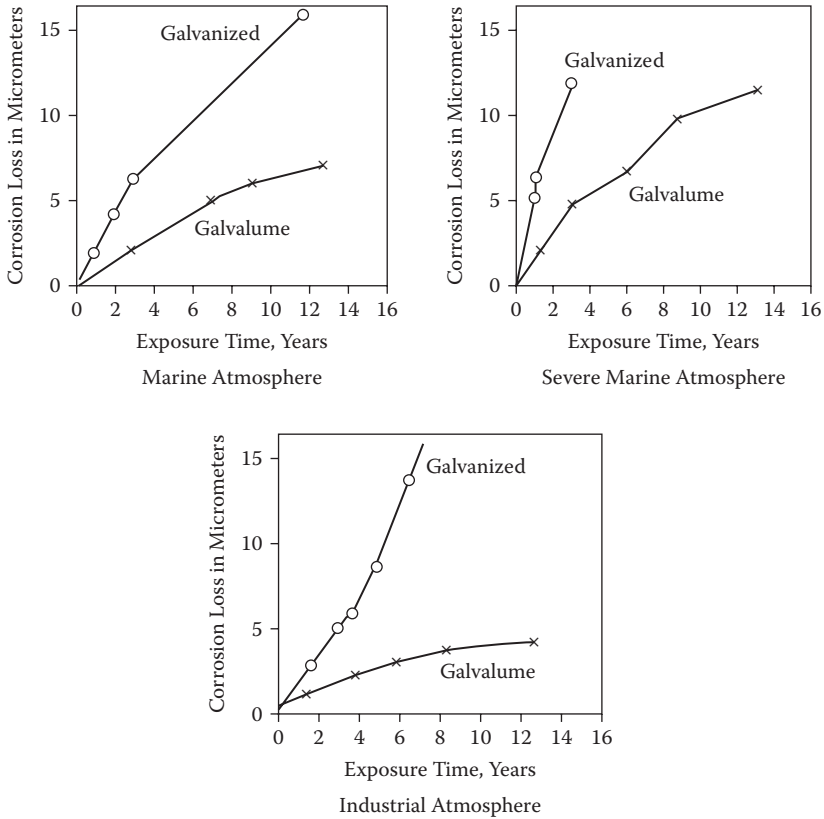

FIGURE 8.15

Thirteen-year exposure of Galvalume in marine and industrial atmospheres.

surface layer, as with pure zinc coatings. As a result, no thickness or weight loss is observed, even after several years of exposure in atmospheric field testing.

It is normally recommended that thermally sprayed coatings be sealed to avoid initial rust stains, to improve appearance, and to facilitate maintenance painting. Sealing is designed to fill pores and give only a thin overall coating, too thin to be directly measurable. Epoxy or acrylic resin systems, having a low viscosity, are used as a sealer.

8.4.1.6 Zinc-Iron Alloy Coatings

As compared with pure zinc, the zinc-iron alloy coatings provide increased corrosion resistance in acid atmospheres but slightly reduced corrosion resistance in alkaline atmospheres.

Electroplated zinc-iron alloy layers containing more than 20% iron provide a corrosion resistance 30% higher than zinc in industrial atmospheres. In other atmospheres, the zinc-iron galvanized coatings provide as good a coating as coatings with an outer zinc layer. Sherardized coatings are superior to electroplated coatings and equal to galvanized coatings of the same thickness. However, the structure of the alloy layer, and its composition, affects the corrosion resistance.

If the zinc layer of a galvanized coating has weathered, or the zinc-iron layer forms the top layer after galvanizing, brown staining can occur on sherardized or hot-dip galvanized coatings in atmospheric corrosion through the oxidation of iron from the zinc-iron alloy layers or from the substrate. Such staining is usually a dull brown rather than the bright red-brown of uncontrolled rust. Usually, there is a substantial intact galvanized layer underneath, leaving the life of the coating unchanged. Unless the aesthetic appearance is undesirable, no action need be taken.

8.4.1.7 Aluminum Coatings

Aluminum coatings protect steel substrates by means of cathodic control, with an original barrier action of an air-formed film, which is chemically inert, and the rapid formation of oxide film by a self-healing ability. Aluminum coatings are excellent in general corrosion resistance. However, they do not act as a sacrificial anode in rural and industrial atmospheres, but do in a chloride area, such as a marine environment. In a nonchloride environment, the formation of red rust occurs at sheared edges and in other defects of an aluminum coating layer. However, the growth of red rust is slow.

Aluminum coatings sealed with organic or composite layers such as etch primer, zinc chromate, etc. will provide long service in seawater environments. The recommended coating thickness plus sealing for the splash zone and submerged zone is 150 μm .

8.4.1.8 Cadmium Coatings

Cadmium coatings are produced almost exclusively by electrodeposition. A cadmium coating on steel does not provide as much cathodic protection to the steel as does a zinc coating because the potential between cadmium and iron is not as great as between zinc and iron. Therefore, it becomes important to minimize defects in the cadmium coating.

Unlike zinc, a cadmium coating will retain a bright metallic appearance. It is more resistant to attack by salt spray and atmospheric condensate than zinc. In aqueous solutions, cadmium will resist attack by strong alkali but will be corroded by dilute acids and aqueous ammonia.

Cadmium coatings should not be allowed to come into contact with food products because cadmium salts are toxic. This coating is commonly used on nuts and bolts but, because of its toxicity, usage is declining.

8.4.1.9 Manganese Coatings

Manganese is very active, having an electrode potential more negative than zinc (Mn: -1.5 V, Zn: -1.03 V, SCE). In a natural atmosphere, a dense corrosion layer builds on the surface of manganese during a very short time period. However, defects in the coating accelerate the anodic dissolution of manganese, thereby shortening the life of the coating. Therefore, manganese is combined with zinc to form a duplex Mn-Zn alloy coating. The types of corrosion products found on these coatings are shown in Table 8.3. The compound γ -Mn₂O is effective for the formation of a barrier. The more γ -Mn₂O₃ in the corrosion products, the denser the layer on the Mn-Zn coating.

Manganese is so negative in electrochemical potential, and active, that its alloy and duplex coatings provide galvanic protection. Mn-Zn alloy coatings exhibit high corrosion resistance, and the corrosion potential of manganese is more negative than that of zinc; therefore, this alloy coating provides cathodic protection to a steel substrate. The structure of the Mn-Zn alloy is composed of the single phase of ϵ in the manganese content range $<20\%$ and ϵ and γ phases in the range above 20% . As the manganese content in the deposit increases, so does the percentage of γ -Mn.

8.5 Mixed Control Protection

The term “conversion coating” is used to describe coatings in which the substrate metal provides ions that become part of the protective coating. The coating layers are composed of inorganic compounds that are chemically inert. These inert compounds on the surface reduce both anodic and cathodic areas and delay the transit of reactive species to the base metal. This results in increases in the slope of the anodic and cathodic polarization curves, thereby decreasing the rate of corrosion of the substrate.

Conversion layers are used for various reasons, including:

1. To improve the adherence of the organic layers
2. To obtain electrically insulating barrier layers
3. To provide a uniform, grease-free surface
4. To provide active corrosion inhibition by reducing the rate of the oxygen reduction reaction, or by passivating the metallic substrate

Conversion coatings belonging in this group are phosphate, chromate, oxide, and anodized coatings. These coatings are composed of corrosion products that have been formed artificially by chemical or electrochemical reactions in selected solutions. The corrosion products thus formed build a barrier protection for the substrate metal. This barrier reduces the active surface area on the base metal, thereby delaying the transport of oxidizers and aggressive species. By so doing, the coating inhibits the formation of corrosion cells. The degree of secondary barrier action depends on the compactness, continuity, and stability of the corrosion product layer.

Each conversion coating protects the base metal against corrosion with two or three of the following protective abilities:

1. Secondary barrier action of corrosion products
2. Inhibiting action of soluble compounds contained in the corrosion products
3. Improvement in paint adhesion by the formation of a uniform corrosion product layer

8.5.1 Phosphate Coatings

When a metal surface is treated with a weak phosphoric acid solution of iron, zinc, or manganese phosphate, phosphate layers are formed. These phosphate coatings are applied to iron and steel, zinc, aluminum, and their alloys.

Phosphate films are formed by the dissolution of base metal and the precipitation of phosphate films. The metal surface must be free of greases, oils, and other carbonaceous materials before immersion in the phosphating solution or before spray application. Baths operating at 120°F (50°C) have pH values of approximately 2 while those operating below 120°F (50°C) have pH values of approximately 3.

The zinc phosphate coating is basically the result of a corrosion process. Reactions of iron and steel in a zinc phosphate solution are as follows:

1. The dissolution of base metal at the anodic sites:

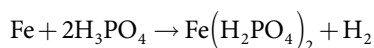

Promotion by the activator:

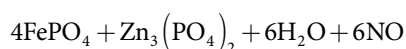
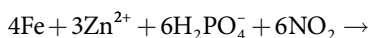
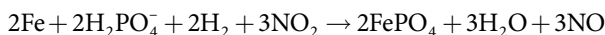

2. Precipitation of phosphate films at the cathodic sites:

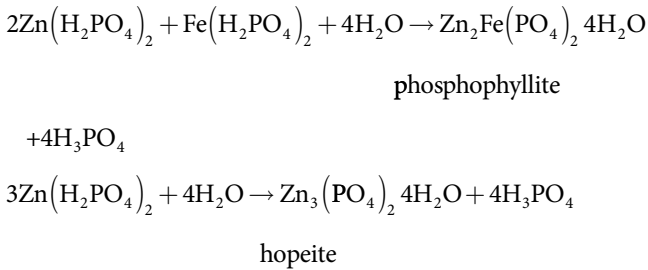

With these reactions, the phosphate film consists of phosphophyllite and hopeite. Phosphate solubilities are lowest in the pH range of 6 to 8. They are stable in neutral environments and are nonelectric conductive compounds. Phosphate film deposits on cathodic areas and anodic sites remain in the form of pinholes. Consequently, the continuity of phosphate films is not as good as those of anodic oxide and chromate films.

Because the barrier action of a conversion film depends on its solubility and continuity, it is evident that the phosphate films provide only limited protection. However, they do provide an excellent base for paint, plastic, and rubber coatings.

The chemical effect of phosphating on the surface is to convert the surface to an alkaline condition, protecting the surface from reactions with oils in paint and to protect against the spread of corrosion from defects. Alkaline residues on the surface of the base metal lead to underfilm corrosion.

Phosphating increases the uniformity in the surface texture and surface area, which improves paint adhesion, and in turn increases the service life of a paint film.

8.5.2 Chromate Coatings

Chromate conversion coatings are formed on aluminum and its alloys, magnesium, zinc, and cadmium. These coatings provide good corrosion protection and improve the adhesion of organic layers. A chromate coating is composed of a continuous layer consisting of insoluble chromium compounds and soluble hexavalent chromium compounds. The coating structure provides a secondary barrier, inhibiting action, and also good adhesion for lacquer films.

Chromate coatings provide their corrosion resistance based on the following three properties:

1. Cr(III) oxide, which is formed by the reduction of Cr(IV) oxide, has poor solubility in aqueous media and thereby provides a barrier layer.

2. Cr(VI) will be included in the conversion coating and will be reduced to Cr(III) to passivate the surface when it is damaged, preventing hydrogen gas from developing.
3. The rate of cathodic oxygen reactions is strongly reduced.

Most chromate conversion coatings are amorphous gel-like precipitates, so they are excellent in continuity. The service life depends on thickness, the characteristics of the base metal, coating conditions — particularly dry heat — and the environmental conditions under which the chromated products are used.

When a chromated product is exposed to the atmosphere, hexavalent chromium slowly leaches from the film, with the result that the surface appearance changes from iridescent yellow to either a green color or to clear. The structure of the film consists of more of the insoluble trivalent chromium compounds. Passivation is provided for any damaged areas by the leached hexavalent chromium.

The longer the time of wetness, the shorter the service life of the coating because chromate coatings absorb moisture and moisture results in the leaching of hexavalent chromium. The leaching behavior of a chromate film is also affected by its aging process, drying process, and long-term storage. Aging of a chromate coating reduces its protective ability.

Chrome baths always contain a source of hexavalent chromium ion (e.g., chromate, dichromate, or chromic acid) and an acid to produce a low pH, which is usually in the range of 0 to 3. A source of fluoride ions is also usually present. These fluoride ions will attack the original (natural) aluminum oxide film, exposing the base metal substrate to the bath solution. Fluoride also prevents the aluminum ions (which are released by the dissolution of the oxide layer) from precipitating by forming complex ions. The fluoride concentration is critical. If the concentration is too low, a conversion layer will not form because of the failure of the fluoride to attack the natural oxide layer, while too high a concentration results in poor adherence of the coating due to reaction of the fluoride with the aluminum metal substrate.

During the reaction, hexavalent chromium is partially reduced to trivalent chromium, forming a complex mixture consisting largely of hydrated hydroxides of both chromium and aluminum:

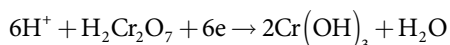

There are two types of processes by which conversion coatings can be produced: chromic acid processes and chromic-phosphoric acid processes. In the formation of the chromic acid based conversion coating, the following overall equation governs:

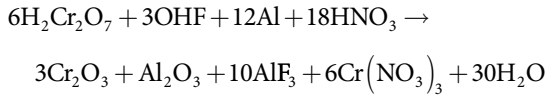

The oxide Cr_2O_3 is better described as an amorphous hydroxide $\text{Cr}(\text{OH})_3$. The conversion color is yellow to brown.

In the chromic acid-phosphoric acid process, the following reaction governs:

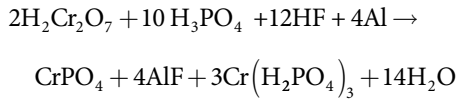

This conversion coating is greenish in color and consists primarily of hydrated chromium phosphate with hydrated chromium oxide concentrated toward the metal.

The barrier action of a chromate coating increases with its thickness. Chromium conversion coatings can be used as a base for paints or alone for corrosion protection. Previously it was described how the leached hexavalent chromium acts as an anodic inhibitor by forming passive films over defects in the coating. Because the films formed on aluminum by the chromic acid-phosphoric acid process contain no hexavalent chromium, they do not provide self-healing from defects.

The service life of a chromate coating depends on the coating thickness. Chromate coatings absorb moisture, and moisture results in the leaching of hexavalent chromium. Therefore, the longer the time of wetness, the shorter the life of the coating. However, as long as leaching of the hexavalent chromium continues, the base metal is protected.

Environmental conditions, particularly time of wetness and temperature, determine the leaching rate. In natural environments, the leaching rate is commonly low. Pollutants in the atmosphere, particularly chloride ions, also increase the rate of deterioration of the film. Chromate conversion coatings provide good corrosion resistance in mild atmospheres, such as indoor atmospheres, and surface appearance. They also provide a good base for organic films.

Chromate conversion coatings are usually applied to zinc and its alloy coated sheets to protect against staining during storage, and to products of zinc-die castings, aluminum and its alloys, and magnesium and its alloys.

8.5.3 Oxide Coatings

Iron or steel articles to be coated are heated in a closed retort to a temperature of 1600°F (871°C), after which superheated steam is admitted. This results in the formation of red oxide (FeO) and magnetic oxide (Fe_3O_4). Carbon

monoxide is then admitted to the retort, reducing the red oxide to magnetic oxide, which is resistant to corrosion. Each operation takes approximately 20 min.

Iron and steel may also be coated by electrolytic means. The article to be coated is made the anode in an alkaline solution (anodic oxidation). These coatings are primarily for appearance, such as for cast iron stove parts.

8.5.4 Anodized Coatings

The electrochemical treatment of a metal serving as an anode in an electrolyte is known as anodizing. Because aluminum's electrode potential is negative and its oxide film is stable in natural environments, surface treatments have been developed for the purpose of producing more stable oxide films. The anodic films formed can be either porous or nonporous, depending on which electrolyte is used.

Porous films result when electrolytes such as sulfuric acid, oxalic acid, chromic acid, and phosphoric acid are used. These films have the advantage of being able to be dyed.

Sulfuric acid is the most widely used electrolyte. A large range of operating conditions can be utilized to produce a coating to meet specific requirements. Hard protective coatings are formed that serve as a good base for dyeing. To obtain the maximum corrosion resistance, the porous coating must be sealed after dyeing. The anodic coating formed, using sulfuric acid as the electrolyte, is clear and transparent on pure aluminum. Aluminum alloys containing silicon or manganese and the heterogeneous aluminum-magnesium alloy yield coatings that range from gray to brown and may be patchy in some cases. The absorptive power of these coatings makes them excellent bases for dyes, especially if they are sealed in nickel or cobalt acetate solution.

It is not recommended to use sulfuric acid as the electrolyte for anodizing work containing joints that can retain the sulfuric acid after removal from the bath. The retained electrolyte will provide sites for corrosion.

When chromic acid is used as the electrolyte, the coatings produced are generally opaque, gray, and iridescent, with the quality being dependent on the concentration and purity of the electrolyte. These are unattractive as compared to those formed using sulfuric acid as the electrolyte. When a 0.03% sulfate is added to the electrolyte, colorless and transparent coatings are formed. These coatings are generally thin, of low porosity, and hence difficult to dye. Black coatings can be obtained in concentrated solutions at elevated temperatures. Attractive opaque surfaces can be obtained by adding titanium, zirconium, and thallium compounds to the electrolyte.

The chromic acid oxidizing process is the only one that can be used on structures containing blind holes, crevices, or difficult-to-rinse areas. Chromic acid anodizing generally increases fatigue strength, while sulfuric acid anodizing may produce decreases in fatigue strength.

Boric acid electrolytes produce a film that is iridescent and oxides in the range of 2500–500 Å. The coating is essentially nonporous.

Oxalic and other organic acids are electrolytes that are used to produce both protective and decorative films. Unsealed coatings are generally yellow in color. These films are harder and more abrasion resistant than conventional sulfuric acid films. However, the specially hard coatings produced under special conditions in sulfuric acid are superior.

The anodized coating consists of two major components: the nonporous barrier layer adjoining the metal and a porous layer extending from the barrier layer to the outer portion of the film. Sulfuric, chromic, and oxalic acid electrolytes form both barrier and porous layers while boric acid electrolytes produce only barrier films.

Anodizing of aluminum provides long-term corrosion resistance and a decorative appearance. Corrosion of the anodized film is induced by SO_x gas and depositions of grime, sulfates, and chlorides. These depositions promote corrosion because they tend to absorb aggressive gases and moisture, thereby increasing the time of wetness and decreasing the pH of the electrolyte at the interface between the depositions and the surface.

Although rain increases the time of wetness, it has the effect of cleaning the surface rather than making the surface corrosive. Some of the depositions are removed by rain. Cleaning with water is one method that helps protect the anodized aluminum from corrosion. In marine atmospheres, the depositions can be removed with water because the depositions are primarily soluble chlorides. However, in industrial atmospheres, detergents are needed because the deposits are greasy.

SO_x gas is the most aggressive pollutant for anodic films. The corrosive effect depends on the concentration, with the corrosion area increasing linearly with concentration.

8.6 Eclipse Molding Framework (EMF) Control Protection

The types of coatings belonging in this category are paints and other organic coatings. Surface conditions are converted to more stable states by coating with organic compounds. This method delays the generation of the electromotive force causing the corrosion of base metal.

The service life of an organic coating is determined by the durability of the coating itself and its adhesive ability on the base metal. The former is the stability of a coating layer as exposed to various environmental factors, and the latter is determined by the condition of the interface between the organic film and the interface.

Details referring to the protective abilities and causes of corrosion of organic polymer films were given in Chapter 6, while the details of the protective abilities and causes of corrosion of paint films were given in Chapter 7.

9

Cathodic Protection

A tremendous investment exists worldwide in underground metallic members such as pipelines, storage facilities, well casings, structure supports, communication cables, etc. When these members are in direct contact with the soil and unprotected, they are subject to corrosion.

Attempts have been made to overcome this problem using various types of coatings applied to the surface. Although such coatings can be effective, invariably small holes or holidays are usually present. These holidays provide access to the uncovered base metal and permit corrosion.

Subsequent repairs can be extremely costly. In addition, undetected failure (or leakage) can cause accidents or lead to safety hazards, such as causing roadways to collapse as a result of an underground water leak, or to environmental hazards resulting from oil leaks.

By cathodic protection, bare metals and holidays in coated metals can be protected from corrosion.

9.1 Background

Cathodic protection is a major factor in metals' corrosion control. When an external electric current is applied, the corrosion rate can be reduced to practically zero. Under these conditions, the metal can remain indefinitely in a corrosive environment without deterioration.

In practice, cathodic protection can be utilized with such metals as steel, copper, brass, lead, and aluminum against corrosion in all soils and almost all aqueous media. Although it cannot be used above the waterline (because the impressed electric current cannot reach outside the electrolyte), it can effectively be used to eliminate corrosion fatigue, intergranular corrosion, stress corrosion cracking, dezincification of brass, or pitting of stainless steels in seawater, or steel in soil.

In 1824, Sir Humphry David reported that by coupling iron or zinc to copper, the copper could be protected against corrosion. The British Admiralty had blocks of iron attached to the hulls of copper-sheathed vessels to provide corrosion protection. Unfortunately, cathodically protected copper is subject to fouling by marine life, which reduced the speed of vessels under sail and forced the admiralty to discontinue the practice. However, the corrosion rate

of the copper had been appreciably reduced. Unprotected copper supplies a different number of copper ions to poison fouling organisms.

In 1829, Edmund Davy was successful in protecting the iron portions of buoys using zinc blocks; and in 1840, Robert Mallet produced a zinc alloy that was particularly suited as a sacrificial anode. The fitting of zinc slabs to hulls of vessels became standard practice as wooden hulls were replaced. This provided localized protection, specifically against the galvanic action of a bronze propeller. Overall protection of seagoing vessels was not investigated again until 1950 when the Canadian Navy determined that the proper use of antifouling paints in conjunction with corrosion-resisting paints made cathodic protection of ships feasible and could reduce maintenance costs.

About 1910 to 1912, the first application of cathodic protection by means of an impressed current was undertaken in England and the United States. Since that time, the use of cathodic protection has become widespread. There are thousands of miles of buried pipe and cables that are protected in this manner.

This form of protection is also used for water tanks, canal gates, submarines, marine piling, condensers, and chemical equipment.

9.2 Theory

Cathodic protection is achieved by applying electrochemical principles to metallic components buried in soil or immersed in water. It is accomplished by flowing a cathodic current through a metal–electrolyte interface, favoring the reduction reaction over the anodic metal dissolution. This enables the entire structure to work as a cathode.

The basis of cathodic protection is shown in the polarization diagram for a copper-zinc cell in Figure 9.1. If polarization of the cathode is continued using an external current beyond the corrosion potential to the open-circuit potential of the anode, both electrodes reach the same potential and no corrosion of the zinc can take place.

Cathodic protection is accomplished by supplying an external current to the corroding metal on the surface of which local action cells operate, as shown in Figure 9.2. Current flows from the auxiliary anode and enters the anodic and cathodic areas of the corrosion cells, returning to the source of the DC current (B). Local action current will cease to flow when the entire metal surface is at the same potential as a result of the cathodic area being polarized by an external current to the open-circuit potential of the anodes. As long as this external current is maintained, the metal cannot corrode.

There are two methods by which cathodic protection can be accomplished. One is by coupling the structure with a more active metal, such as zinc or magnesium. This produces a galvanic cell in which the active metal works as an anode and provides a flux of electrons to the structure. The structure then

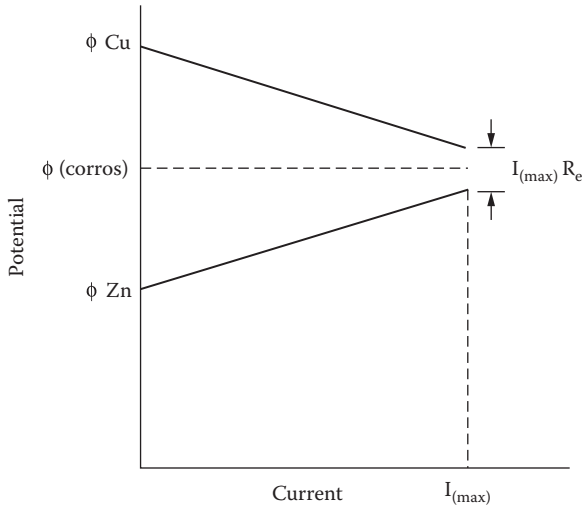

FIGURE 9.1
Polarization of copper-zinc cell.

becomes the cathode and is protected, while the anode is destroyed progressively and is called a sacrificial anode.

The second method is to impress a direct current between an inert anode and the structure. The structure receives the excess of electrons, which protects it. About 1910 to 1912, the first application of cathodic protection by means of an impressed electric current was undertaken in the United States and England. Since that time, the general use of cathodic protection has been widespread.

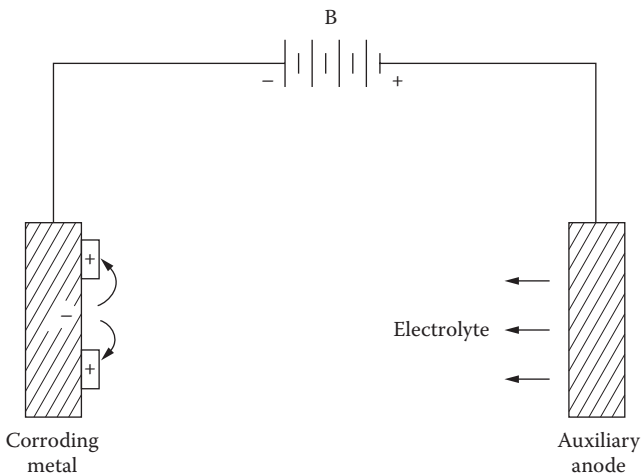

FIGURE 9.2
Cathodic protection using impressed current on a local action cell.

There are thousands of miles of buried pipelines and cables that are protected in this manner. This form of protection is also used for the protection of water tanks, submarines, canal gates, marine piping, condensers, and chemical equipment.

9.2.1 Sacrificial Anodes

It is possible, by the selection of an anode constructed of a metal more active in the galvanic series than the metal to be protected, to eliminate the need for an external DC current. A galvanic cell will be established with the current direction exactly as described using an impressed electric current. These sacrificial anodes are usually composed of magnesium or magnesium-based alloys. Occasionally, zinc or aluminum has been used. Because these anodes are essentially sources of portable electrical energy, they are particularly useful in areas where electric power is not available, or where it is uneconomical or impractical to install power lines for this purpose.

Most sacrificial anodes in use in the United States are of magnesium construction. Approximately 10 million pounds of magnesium is annually used for this purpose. The open-circuit potential difference between magnesium and steel is about 1 V. This means that one anode can protect only a limited length of pipeline. However, this low voltage can have an advantage over higher impressed voltages in that the danger of overprotection to some portions of the structure is less; and because the total current per anode is limited, the danger of stray-current damage to adjoining metal structures is reduced.

Magnesium anode rods have also been placed in steel hot-water tanks to increase the life of these tanks. The greatest degree of protection is afforded in "hard" waters where the conductivity of the water is greater than in "soft" waters.

9.2.1.1 Anode Requirements

To provide cathodic protection, a current density of a few milliamps (mA) is required. Therefore, to determine the anodic requirements, it is necessary to know the energy content of the anode and its efficiency. From this data the necessary calculations can be made to size the anode, determine its expected life, and determine the number of anodes required. As previously indicated, the three most common metals used are magnesium, zinc, and aluminum. The energy content and efficiency of these metals are as follows:

Metal	Theoretical Energy Content (A h/lb)	Anodic Efficiency (%)	Practical Energy (PE) Constant (A h/lb)
Magnesium	1000	50	500
Zinc	370	90	333
Aluminum	1345	60	810

The number of pounds of metal required to provide a current of 1 A for a year can be determined from the following equation:

$$\text{lb metal/A-yr} = \frac{8760 \text{ h/yr}}{\text{PE}}$$

For magnesium this would be

$$\text{lb Mg/A-yr} = \frac{8760}{500} = 17.52$$

The number of years (YN) for which 1 lb of metal can produce a current of 1 mA is determined from the following equation:

$$\text{YN} = \frac{\text{PE}}{10^{-3} \text{ A } 8760 \text{ h/yr}}$$

For magnesium this would be

$$\frac{500}{10^{-3}(8760)} = 60 \text{ years}$$

The life expectancy (L) of an anode of W lb, delivering a current of 1 mA is calculated as follows:

$$L = \frac{\text{YN}(W)}{1}$$

For magnesium this would be

$$L_{\text{Mg}} = \frac{60(W)}{1}$$

that is based on a 50% anodic efficiency. Because actual efficiencies tend to be somewhat less, it is advisable to apply a safety factor and multiply the result by 0.75.

The current required to secure protection of a structure and the available cell voltage between the metal structure and sacrificial anode determine the number of anodes required. This can be illustrated by the following example:

Assume that an underground pipeline has an external area of 200 ft² and a soil resistivity of 600 Ω·cm. Field tests indicate that 6 mA/ft² is required for protection. To provide protection for the entire pipeline (6 mA/ft²) (200 ft²)

= 1200 mA. Magnesium anodes used in this particular soil have a voltage of -1.65 V, or a galvanic cell voltage of

$$E_{\text{cell}} = E_C - E_A = -0.85 - (-1.65) = +0.8 \text{ V}$$

The resistance is therefore

$$R = \frac{V}{I} = \frac{0.8}{1.2} = 0.67 \ \Omega$$

As the number of anodes is increased, the total resistance of the system decreases. Each anode that is added provides a new path for current flow, parallel to the existing system. The relationship between the resistance of the system and the anodes is shown in the Sunde equation:

$$R = \frac{0.00521P}{NL} = \left(2.3 \log \frac{8L}{d-1} + \frac{2L}{S} 2.3 \log 0.656N \right)$$

where R = resistance (ohms), P = soil resistivity (ohm-cm), N = number of anodes, L = anode length (ft), d = diameter of anode (ft), and S = distance between anodes (ft).

Figure 9.3 shows the typical plotting of the results of this equation. Different anodic shapes will have different curves.

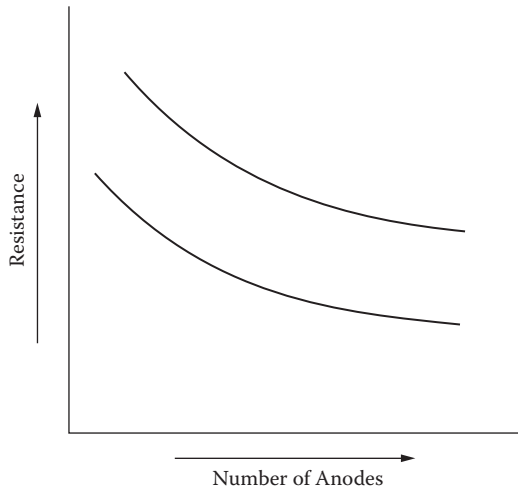

FIGURE 9.3
Plot of Sunde equation.

9.2.1.2 Anode Materials and Backfill

The use of magnesium as a sacrificial anode has already been discussed. For use with impressed current, auxiliary anodes are usually formed of scrap iron or graphite. Scrap iron is consumed at a considerably faster rate than graphite (15 to 20 lb/A-yr vs. 2 lb/A-yr); however, graphite costs more — both initially and in operating expense. Graphite requires more power than scrap iron. It is also more fragile, and greater care must be taken during installation. Under certain conditions, the advantage of the 8 to 10 times longer life outweighs the added costs, particularly in areas where replacement poses problems.

Platinum-clad or 2% silver-lead electrodes that use impressed current have been used for the protection of structures in seawater. The latter anodes are estimated to last 10 years, whereas sacrificial magnesium anodes require replacement every 2 years. On occasion, aluminum electrodes have been used in freshwaters.

Because the effective relativity of soil surrounding an anode is limited to the immediate area of the electrode, the local distance is generally reduced by using backfill. For impressed current systems, the anode is surrounded with a thick bed of coke mixed with 3 to 4 parts gypsum to 1 part sodium chloride. The consumption of the anode is reduced somewhat because the coke backfill is a conductor and carries part of the current. If the anode is immersed in a riverbed, lake, or ocean, backfill is not required.

Auxiliary anodes need not be consumed to fulfill their purpose. Conversely, sacrificial anodes are consumed no less to supply an equivalent current than is required by Faraday's law.

For magnesium anodes, backfill has the advantage of reducing the resistance of insulating corrosion-product films as well as increasing the conductivity of the immediate area. A typical backfill consists of a mixture of approximately 20% bentonite (for retention of moisture), 75% gypsum, and 5% sodium sulfate.

9.2.2 Impressed Current Systems

For these systems, the source of electricity is external. A rectifier converts high voltage to a low-voltage DC current. This direct current is impressed between buried anodes and the structure is protected.

It is preferable to use inert anodes, which will last for the longest possible time. Typical materials used for these anodes are graphite, silicon, titanium, and niobium plated with platinum.

For a given voltage, the current is limited by electrolyte resistivity and by the anodic and cathodic polarization. With the impressed current system, it is possible to impose whatever potential is necessary to obtain the current density required, by means of the rectifier.

Electric current flows in the soil from the buried anode to the underground structure, to be protected. Therefore, the anode must be connected to the

positive pole of the rectifier, and the structure to the negative pole. All cables from the rectifier to the anode and to the structure must be electrically insulated. If not, those from the rectifier to the anode will act as an anode and deteriorate rapidly, while those from the rectifier to the structure may pick up some of the current, which would then be lost for protection.

9.2.2.1 Current Requirements

The specific metal and environment will determine the current density required for complete protection. The applied current density must always exceed the current density equivalent to the measured corrosion rate under the same conditions. Therefore, as the corrosion rate increases, the impressed current density must be increased to provide protection.

Factors that affect current requirements are:

1. The nature of the electrolyte
2. The soil resistivity
3. The degree of aeration

The more acidic the electrolyte, the greater the potential for corrosion and the greater the current requirement. Soils that exhibit a high resistance require a lower cathodic current to provide protection. In an area of violent agitation or high aeration, an increase in current will be required. The required current to provide cathodic protection can vary from 0.5 to 20 mA/ft² of bare surface.

Field testing may be required to determine the necessary current density to provide cathodic protection in a specific area. These testing techniques will only provide an approximation. After completion of the installation, it will be necessary to conduct a potential survey and make the necessary adjustments to provide the desired degree of protection.

9.2.2.2 Anode Materials and Backfill

Although it is generally preferred to use inert anodes, it is possible to use scrap iron. Scrap iron is consumed at a considerably faster rate than graphite or other inert anode material. The advantage of scrap iron is a lower initial cost and lower operating cost because its power requirements are less. In areas where replacement poses a problem, the cost of using the more inert anodes outweighs the reduced cost of the scrap iron.

Platinum-clad or 2% silver-lead electrodes have been used for the protection of structures in seawater and are estimated to last 10 years, whereas sacrificial magnesium anodes have a life of 2 years.

Because the effective resistivity of the soil surrounding an anode is limited to the immediate area of the anode, this local resistance is usually reduced using backfill. The anode is usually surrounded by a thick bed of coke mixed

with 3 or 4 parts gypsum to 1 part sodium chloride. The consumption of the anode is reduced somewhat because the coke backfill carries some of the current. Backfill is not required when the anode is immersed in a riverbed, lake, or ocean.

9.2.2.3 Testing for Completeness of Protection

Once the system has been installed, it must be tested for completeness of protection. The preferred method is to take potential measurements. By measuring the potential of the protected structure, the degree of protection, including overprotection, can be determined. The basis for this determination is the fundamental concept that cathodic protection is complete when the protected structure is polarized to the open-circuit anodic potential of the local action cells.

The reference electrode is placed as close as possible to the protected structure to avoid and to minimize any error caused by internal resistance (IR) drop through the soil. For buried pipelines, a compromise location is directly over the buried pipe at the soil surface because cathodic protection currents flow mostly to the lower surface and are minimum at the upper surface of the pipe buried a few feet below the surface.

The potential for steel is -0.85 V vs. the copper-saturated copper sulfate half-cell, or 0.53 V on the standard hydrogen scale. The theoretical open-circuit anodic potential for other metals may be calculated using the Nernst equation. Several typical calculated values are shown in the table:

Metal	E° (V)	Solubility Product $M(OH)_2$	OH_2 Scale (V)	O vs. $Cu-CuSO_4$ Reference (V)
Iron	0.440	1.8×10^{-15}	-0.59	-0.91
Copper	-0.337	1.6×10^{-19}	0.16	-0.16
Zinc	0.763	4.5×10^{-17}	-0.93	-1.25
Lead	0.126	4.2×10^{-15}	-0.27	-0.59

Overpotential of steel structures, to a moderate degree, does not cause any problems. The primary disadvantages are waste of power and increased consumption of auxiliary anodes. When overprotection is excessive, hydrogen can be generated at the protected structure in sufficient quantities to cause blistering of organic coatings, hydrogen embrittlement of the steel, or hydrogen cracking.

Overprotection of systems with amphoteric metals (e.g., tin, lead, aluminum, zinc) will damage the metal by causing increased attack instead of reduced corrosion. This stresses the need for making potential measurements of protected structures.

There are several ways that the effectiveness of protection can be checked. The first two methods are qualitative and do not provide data about

whether enough or more than enough current is being supplied. Potential measurements, the third method, is of prime importance.

1. *Coupon test.* A metal coupon is shaped to conform to the contour of the pipe, weighed, and attached by a braze-connected cable to the pipe. Both the cable and the surface between the coupon and the pipe are coated with coal tar. The coupon is allowed to remain buried for weeks or months, uncovered, cleaned, and weighed. The weight loss, if any, is an indication as to whether or not the cathodic protection is complete.
2. *Colorimetric test.* A piece of absorbent paper soaked in potassium ferricyanide solution is placed in contact with a cleaned section of the buried pipeline and the soil replaced. After a relatively short time, the paper is retrieved. A blue ferrous/ferricyanide reaction indicates incomplete cathodic protection, whereas an absence of blue on the paper indicates that cathodic protection is complete.
3. *Potential measurements.* By measuring the potential of the protected structure, the degree of protection, including overprotection, can be quantitatively determined. This measurement is the generally accepted criterion and is used by corrosion engineers. The basis for this determination is the fundamental concept that cathodic protection is complete when the protected structure is polarized to the open-circuit anodic potential of the local action cells.

The reference electrode for making this measurement should be placed as close as possible to the protected structure to avoid and to minimize an error caused by internal resistance (IR) drop through the soil. Such IR drops through corrosion product films or insulating coatings will still be present regardless of precautions taken, tending to make the measured potential more active than the actual potential at the metal surface. For buried pipelines a compromise location is taken directly over the buried pipe at the soil surface because cathodic protection currents flow mostly to the lower surface and are minimum at the upper surface of the pipe buried a few feet below the soil surface.

9.3 Use with Coatings

Insulating coatings are advantageous to use with either impressed current or sacrificial anodes when supplying cathodic protection. These coatings need

not be pore-free because the protective current flows preferentially to the exposed metal areas that require protection. Such coatings are useful in distributing the protective current, in reducing total current requirements, and in extending the life of the anode. For example, in a coated pipeline, the current distribution is greatly improved over that of a bare pipeline, the number of anodes and the total current required are less, and one anode can protect a much longer section of pipeline. Because the Earth is a good electrical conductor and the resistivity of the soil is localized only within the region of the pipeline or electrodes, the limiting length of pipe protected per anode is imposed by the metallic resistance of the pipe and not the resistance of the soil.

One magnesium anode is capable of protecting approximately 100 ft (30 m) of bare pipeline, whereas it can provide protection for approximately 5 mi (8 km) of coated pipeline.

In a hot-water tank coated with glass or an organic coating, the life of the magnesium anode is extended and more uniform protection is supplied to the tank. Without the coating, the tendency is for excess current to flow to the side and insufficient current flows to the top and bottom. Because of these factors, cathodic protection is usually provided with coated surfaces.

9.4 Economics

The cost of cathodic protection is more than recovered by reduced maintenance costs, by reduced installation costs, or both. For buried pipelines, the guarantee that there will be no corrosion on the soil side of the pipe has made it economically feasible to transport oil and high-pressure natural gas across the North American continent. It has also permitted the use of thinner-walled pipe. Wall thicknesses need only be sufficient to withstand the internal pressures. No extra allowance has to be added for external corrosion. This saving alone has sometimes more than paid for the installation of the cathodic equipment.

Similarly, other cathodic protection systems have more than paid for their installation costs, reduced maintenance costs by longer operating periods between routine inspections and maintenance periods.

10

Corrosion Inhibitors

Corrosion of metallic surfaces can be controlled or reduced by the addition of chemical compounds to the corrodent. This form of corrosion control is called *inhibition* and the compounds added are known as *corrosion inhibitors*. These inhibitors will reduce the rate of either anodic oxidation, cathodic reduction, or both. The inhibitors themselves form a protective film on the surface of the metal. It has been postulated that the inhibitors are adsorbed onto the metal surface either by physical (electrostatic) adsorption or chemisorption.

Physical adsorption is the result of electrostatic forces between the organic ions and the electrically charged metal surface. Chemisorption is the transfer, or sharing, of the inhibitor molecule's charge to the metal surface, forming a coordinate-type bond. The adsorbed inhibitor reduces the corrosion rate of the metal surface either by retarding the anodic dissolution reaction of the metal, by the cathodic evolution of hydrogen, or both.

Inhibitors can be classified in many different ways according to:

1. Their chemical nature (organic or inorganic substances)
2. Their characteristics (oxidizing or nonoxidizing compounds)
3. Their technical field of application (pickling, acid cleaning, descaling, cooling water systems, etc.)

The most common and widely known use of inhibitors is their application in automobile cooling systems and boiler feed waters.

By considering the electrochemical nature of corrosion processes, constituted by at least two electrochemical partial reactions, inhibition may be defined on an electrochemical basis. Inhibitors will reduce the rates of either or both of these partial reactions (anodic oxidation and/or cathodic reduction). As a consequence, there can be anodic, cathodic, and mixed inhibitors.

Inhibitors can be used in electrolytes at different pH values, from acid to near-neutral or alkaline solutions. Because of the very different situations created by changing various factors such as medium and inhibitor in the system, metal/aggressive medium/inhibitor, various inhibition mechanisms must be considered.¹⁻⁶

An accurate analysis of the different modes of inhibiting electrode reactions, including corrosion, was carried out by Fisher.⁷ He distinguished among various mechanisms of action such as:

- Interface inhibition
- Electrolyte layer inhibition
- Membrane inhibition
- Passivation

Subsequently, Lorenz and Mansfield⁸ proposed a clear distinction between interface and interphase inhibition, representing two different types of retardation mechanisms of electrode reactions, including corrosion. Interface inhibition presumes a strong interaction between the inhibitor and the corroding surface of the metal.^{1, 7, 9} In this case, the inhibitor adsorbs as a potential-dependent, two-dimensional layer. This layer can affect the basic reactions in different ways:

- By a geometric blocking effect of the electrode surface because of the adsorption of a stable inhibitor at a relatively high degree of coverage of the metal surface.
- By blocking the effect of the surface sites because of the adsorption of a stable inhibitor at a relatively low degree of coverage.
- By reactive coverage of the metal surface. In this case, the adsorption process is followed by electrochemical or chemical reactions of the inhibitor at the interface.

According to Lorenz and Mansfield,⁸ interface inhibition occurs in corroding systems exhibiting a bare metal surface in contact with the corrosive medium. This condition is often realized for active metal dissolution in acid solutions.

Interphase inhibition presumes a three-dimensional layer between the corroding surface and the electrolyte.^{7, 10, 11} Such layers generally consist of weakly soluble corrosion products and/or inhibitors. Interphase inhibition is mainly observed in neutral media with the formation of porous or nonporous layers. Clearly, the inhibition efficiency strongly depends on the properties of the formed three-dimensional layer.

10.1 Inhibitor Evaluation

Because there may be more than one inhibitor suitable for a specific application, it is necessary to have a means of comparing the performance of each. This can be done by determining the inhibitor efficiency according to the following correlation:

$$I_{\text{eff}} = \frac{R_0 - R_i}{R_0} \times 100$$

where I_{eff} is the efficiency of the inhibitor (%), R_0 is the corrosion rate of the metal without inhibitor present, and R_i is the corrosion rate of the metal with inhibitor present. R_0 and R_i can be determined by any of the standard corrosion testing techniques. The corrosion rate can be measured in any unit, such as weight loss (mpy), as long as the units are consistent across both tests.

10.2 Classification of Inhibitors

Inhibitors can be classified in several ways, as previously indicated. Inhibitors will be classified and discussed under the following headings:

1. Passivation inhibitors
2. Organic inhibitors
3. Precipitation inhibitors
4. Vapor phase inhibitors

10.2.1 Passivation Inhibitors

10.2.1.1 Mechanism of Passivation

Passivators in contact with a metal surface act as depolarizers initiating high current densities at residual anodic areas that exceed $i_{(\text{critical})}$ for passivation. The only ions that can serve as passivators are those that have both an oxidizing capacity in the thermodynamic sense (noble oxidation-reduction potential) and that are readily reduced (shallow cathodic polarization curve (Figure 10.1). Hence, SO_4^- or ClO_4^- ions are not passivators for iron because they are not readily reduced, nor are NO_3^- ions compared to NO_2^- , because nitrates are reduced less rapidly than are nitrites, the former reducing too sluggishly to achieve the required high value of $i_{(\text{critical})}$. The extent of chemical reduction on initial contact of a passivator with metal, according to this viewpoint, must be at least chemically equivalent to the amount of passive film formed as a result of such reduction. For the passive film on iron, this is on the order of 0.01 coulomb/cm² of apparent surface. The total equivalents corresponding to chemical reduction of chromates is found to be of this order and is probably also the same for other passivators acting on iron. The amount of chromate reduced in the passivation process derives

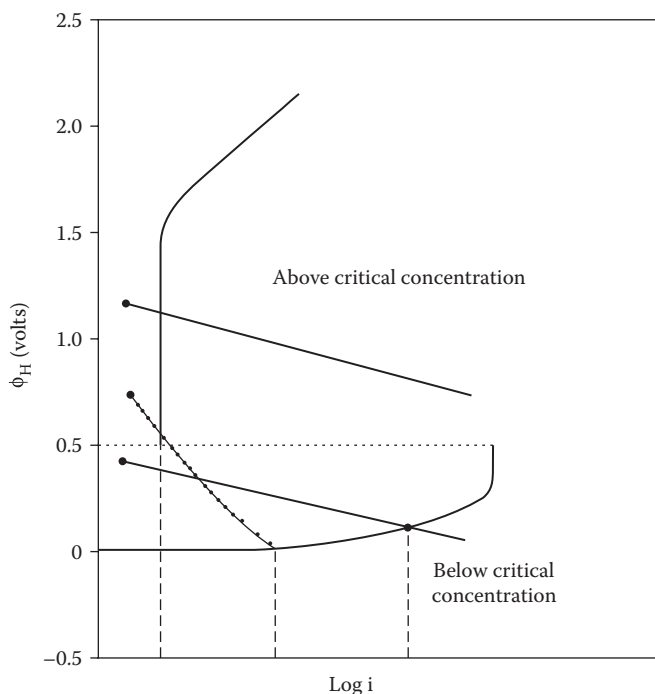
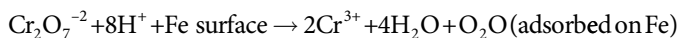

FIGURE 10.1

Polarization curves that show effect of passivator concentration on the corrosion of iron. An oxidizing substance that reduces sluggishly does not induce passivity (dotted cathodic polarization curve).

from measurements¹²⁻¹⁴ of residual radioactivity of a washed iron surface after exposure to a chromate solution containing Cr 51. The following reaction applies, assuming, as measurements appear to substantiate,¹⁵ that all reduced chromate (or dichromate) remains on the metal surface as adsorbed Cr^{13} or as hydrated Cr_2O_3 :



$$E^0 = 0.79 \text{ volt}$$

Residual radioactivity accounts for 3×10^{16} Cr atoms/cm² (1.5×10^{-7} equivalents or 0.515 coulomb passive film substance/cm²). The above equation assumes an adsorbed passive film structure, but the same reasoning applies whatever the structure.

Reduction of the passivator continues at a low rate after passivity is achieved in the absence of dissolved oxygen to the value of i_{passive} slowly forming iron oxide and reduction products of chromate. From the observed corrosion rates

of iron in contact with chromate solutions (<0.0001 ipy), it is estimated that i_{passive} is less than $0.3 \mu\text{amp}/\text{cm}^2$. The rate of reduction increases with factors that increase i_{passive} such as the H^+ concentration, temperature, and Cl^- concentration. It is found in practice that less chromate is consumed as exposure time increases, which may be caused, in part, by a secondary film of oxides eventually covering the metal, thereby exposing less surface at which the passive film requires repair.

For optimum inhibition, the concentration of passivator must exceed a certain critical value. Below this concentration, passivators behave as active depolarizers and increase the corrosion rate in localized areas (pits). Lower concentrations of passivator correspond to more active values of the oxidation-reduction potential and eventually the cathodic polarization curve intersects the anodic curve in the active region instead of in the passive region (Figure 10.1).

The critical concentration for CrO_4^{2-} , NO_2^- , MoO_4^{2-} , or WO_4^{2-} is about 10^{-3} to 10^{-4} M.¹⁶ A concentration of 10^{-3} M Na_2CrO_4 is equivalent to 0.016%, or 160 ppm. Chloride ions and elevated temperatures increase i_{critical} as well as i_{passive} , which in effect raise the critical passivator concentration to higher values.

Should passivator concentration fall below the critical value in stagnant areas (e.g., at threads of a pipe or at crevices), the active potential of such areas in galvanic contact with passive areas elsewhere of noble potential promotes corrosion (pitting) at the active areas (passive-active cells). For this reason, it is important to maintain the concentration of passivators above the critical value at all portions of the inhibited system by the use of stirring, rapid flow rates, and avoidance of crevices or of surface films of grease and other dirt. Because consumption of passivators increases with an increase in chloride and sulfate ions, it is also essential to maintain as low a concentration of these ions as possible.

This is the most effective, and consequently, the most widely used type of inhibitor. Chromatics are the least expensive inhibitors for use in water systems and are widely used in the recirculating-cooling systems of internal combustion engines, rectifiers, and cooling towers. Sodium chromate in concentrations of 0.04 to 0.1% is used for this purpose. At higher temperatures or in freshwater that has chloride concentrations above 10 ppm, higher concentrations are required. If necessary, sodium hydroxide is added to adjust the pH to a range of 7.5 to 9.5. If the concentration of chromate falls below a concentration of 0.016%, corrosion will be accelerated. Therefore, it is essential that a periodic colormetric analysis be conducted to prevent this from happening.

Recent environmental regulations have been imposed on the use of chromates. They are toxic, and in prolonged contact with the skin can cause a rash. It is usually required that the Cr^{6+} ion be converted to Cr^{3+} before discharge. The Cr^{3+} ion is insoluble and can be removed as a sludge, whereas the Cr^{6+} ion is water soluble and toxic. Even so, the Cr^{3+} sludge is classified as a hazardous waste and must be constantly monitored. Because of the chromate

ions cost of conversion, the constant monitoring required, and the disposal of the hazardous waste, the economics of the use of these inhibitors are not as attractive as they formerly were.

Because most antifreeze solutions contain methanol or ethylene glycol, chromates cannot be used for this application because they have a tendency to react with organic compounds. In these applications, borax ($\text{Na}_2\text{B}_4\text{O}_7 \cdot 10\text{H}_2\text{O}$) that has added sulfonated oils to produce an oily coating and mercaptobenzothiazole are used. The latter material is a specific inhibitor for copper.

Nitrates are also used in antifreeze-type cooling water systems because they have little tendency to react with alcohols or ethylene glycol. Because they are gradually decomposed by bacteria, they are not recommended for use in cooling tower waters. Another application for nitrites is as a corrosion inhibitor for the internal surfaces of pipelines used to transport petroleum products or gasoline. Such inhibition is accomplished by continuously injecting 5 to 30% sodium nitrite solution into the line.

At lower temperatures, such as in underground storage tanks, gasoline can be corrosive to steel as dissolved water is released. This water, in contact with large quantities of oxygen dissolved in the gasoline, corrodes the steel and forms large quantities of rust. The sodium nitrite enters the water phase and effectively inhibits corrosion.

Nitrites are also used to inhibit corrosion by cutting-oil-water emulsions used in the machining of metals.

Passivating inhibitors can usually cause pitting and accelerate corrosion when concentrations fall below minimum limits. For this reason, it is essential that constant monitoring of the inhibitor concentration take place.

Chromates are applied mostly as inhibitors for recirculating the cooling water of internal combustion engines, rectifiers, and cooling towers. The concentration of Na_2CrO_4 used for this purpose is about 0.04 to 0.1%, the higher concentrations being employed at higher temperatures or in freshwaters of chloride concentrations above 10 ppm. The pH is adjusted, if necessary, to 7.5 to 9.5 by the addition of NaOH. Periodic colorimetric analysis is required to ensure that the concentration remains above the critical 10^{-3} M or 0.016% Na_2CrO_4 . Sometimes, combinations of chromates and polyphosphates or other inhibitors permit the concentration of chromates to fall below the critical level. This results in some sacrifice of inhibiting efficiency but with adequate protection against pitting for the treatment of very large volumes of water employing cooling towers.

Corrosion rates of mild steel as a function of chromate and chloride concentration at various temperatures are shown in Table 10.1. Such data in the region of the critical chromate concentration are not readily reproduced because of erratic pitting behavior.

Nitrites are inhibitors only above about pH 6.0. In more acidic environments, they tend to decompose, forming volatile nitric oxide and nitrogen peroxide. In common with other passivators, they tend to induce pitting at concentrations

TABLE 10.1

Effect of Chromate Concentration, Chlorides, and Temperature on Corrosion of Mild Steel

Velocity of Spec: 37 cm/s: 14-day tests					
Na ₂ Cr ₂ O ₇ ·2H ₂ O (g/L)		0	0.1	0.5	1.0
%NaCl	Temp. (°C)	Corrosion Rate (ipy)			
0	20	0.021	0.0001	0.0001	0.0000
	75	0.036	0.014 ^a	0.0004	0.0002
	95	0.017	0.011 ^a	0.0004	0.0000
0.002	20	0.026	0.0006	0.0000	0.0000
	75	0.067	0.005 ^a	0.0002	0.0000
	95	0.021	0.017 ^a	0.005 ^a	0.0003
0.05	20	0.031	0.0012	0.0015	0.0008
	75	0.085	0.002	0.003	0.002
	95	0.023	0.007 ^a	0.005 ^a	0.002
3.5	20	0.024	0.0017	0.0016	0.0015
22.0	20	0.007	0.0009	0.0006	0.0013

^a Pitted.

near the critical value in the presence of Cl⁻ or SO₄²⁻ ions. In this regard, nitrites are less sensitive to Cl⁻ than to SO₄²⁻ contrary to the situation for chromates.

Zinc molybdate has been suggested as an inhibiting pigment for paints, being white instead of the characteristic yellow of chromates. It is also said to be less toxic than chromates.

10.2.2 Organic Inhibitors

A variety of organic compounds are used as inhibitors. Common among them are amines, imines, thiourea, mercaptans, guanidine, and aldehydes. These compounds are chemisorbed on the metal surface, forming a monolayer that interferes with both the anodic and cathodic processes, although in many cases the effect is equal. The chemisorption is effected through the presence of a polar group in the molecular structure by which the molecules can attach themselves to the metal surface. These include sulfur, nitrogen, amine, phosphorous, and hydroxyl groups.

Cationic inhibitors (such as amines) or anionic inhibitors (such as sulfonates) will be adsorbed preferentially, depending on whether the metal is negatively or positively charged with respect to the solution. Amines show better performance as inhibitors for steel in phosphoric acid in the presence of iodides. The explanation for this synergism is that the adsorption of iodide ions shifts the surface charge of steel to more negative values, where the adsorption of positively charged amines is favored. The fact that a certain

organic compound acts as a good inhibitor for some metals but not others is explained from this specific electronic interaction of the polar groups with the metal surface.

The molecular structure and size of the organic compound influence their inhibitive action. The structures with benzene rings are particularly effective inhibitors. Primary amines become more effective as the chain length increases. This is presumably because of the steric effect (i.e., diffusion barrier) provided by long chains. However, for mercaptans and aldehydes, the efficiency decreases with the increasing chain length. The sharp decrease in corrosion rate with organic inhibitors is shown in Figure 10.2.

Sodium benzoate, sodium cinnamate, and sodium pyrophosphate are examples of nonoxidizing compounds that effectively passivate iron in the near-neutral range, apparently by facilitating the adsorption of dissolved oxygen. As little as 10^{-4} M sodium benzoate (0.0014%) effectively inhibits in aerated distilled water, but inhibition is not observed in deaerated water.

Organic inhibitors find application as pickling inhibitors. Acid pickling of hot-rolled steel is necessary to remove mill scale. Pickling inhibitors resist corrosion of the substrate metal. These inhibitors are used for acid cleaning

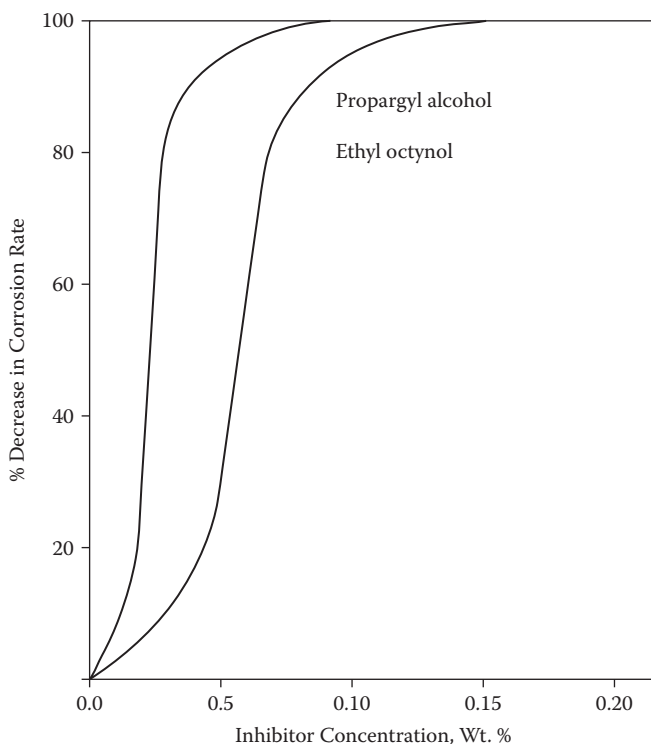

FIGURE 10.2

Effect of concentration of organic inhibitors on corrosion rate.

of the pipes clogged with rust or to remove limestone crust from inside the boiler tubes. Typical examples of pickling inhibitors are quinolin ethiodide, *o*- and *p*-tolylthiourea, hexamethylene tetramine, formaldehyde, and *p*-thio-cresol. They are added in concentrations of 0.01 to 0.1%. Organic inhibitors are also added to oils, greases, and waxes used as slushing compounds to temporarily protect steel surfaces from rusting during shipment or storage.

10.2.3 Precipitation Inhibitors (Cathodic Inhibitors)

Precipitation inhibitors are compounds that cause the formation of precipitates on the surface of the metal, thereby providing a protective film. Cathodic inhibitors interfere with the cathodic processes and the rate of corrosion thereby decreases. They fall into three categories: cathodic precipitates, oxygen scavengers, and hydrogen evolution poisons.

Calcium and magnesium carbonates, which are often present in natural waters, can be precipitated to form protective cathodic deposits with the adjustment of pH. The addition of zinc also inhibits corrosion by precipitating insoluble $\text{Zn}(\text{OH})_2$ at increased alkalinity on the cathodic areas according to the reaction:

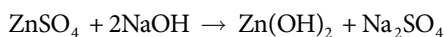

Hydrogen evolution poisons interfere with the formation of hydrogen gas ($2\text{H}_{\text{ads}} \rightarrow \text{H}_2$) to retard the overall rate of the cathodic reaction of hydrogen evolution. The corrosion rate consequently decreases. Sulfides, selenides, and compounds (usually oxides) of arsenic, antimony, and bismuth act as hydrogen evolution poisons. They are effective inhibitors in strong acids where the hydrogen evolution rate is controlling in the corrosion process. One difficulty is caused by these inhibitors: they cause blistering and hydrogen embrittlement in certain grades of steel because of the entry of atomic hydrogen into the metal. Also, arsenic, being toxic, is restricted in use.

10.2.4 Vapor-Phase Inhibitors

Vapor phase inhibitors (VPIs) are compounds with low vapor pressures (0.0002 to 0.4 mm Hg). In a closed system, they volatilize and the vapor condenses on the metal surface to provide protection. In boilers, volatile basic compounds such as morpholine and ethylenediamine are transported with steam to the condenser tubes; this prevents corrosion of the tubes by neutralizing carbonic acid and making the environment alkaline. In closed containers and packages, volatile solids such as nitrite, carbonate, and benzoate salts of dicyclohexylamine, cyclohexylamine, and hexamethylene imine are used for temporary protection of critical machine parts, ball bearings, cold-rolled steel coils, etc. during storage or transportation.

Dicyclohexylamine nitrite is a widely used vapor inhibitor that is often impregnated in the waxed paper or cardboard used for wrapping and packaging. One gram of this inhibitor saturates about 550 M³ of air and the protection to steel is provided over years. Cyclohexylamine carbonate has a higher vapor pressure and is used in packages that must be opened and closed repeatedly.

The mechanism of inhibition is not the same for all vapor-phase inhibitors. Nitrite ions and benzoate ions in association with oxygen present passivate the steel surface. Carbonate provides alkalinity to the environment and the organic amine portion of the inhibitor effectively provides protection through adsorption.

While the vapor-phase inhibitors, in general, are effective in the prevention of corrosion in steel, they accelerate the corrosion of some nonferrous metals. The vapor-phase inhibitors based on nitrobenzoate organic compounds have been reported to protect ferrous, copper, and other alloy systems.

10.3 Inhibition in Acid Solution

The inhibition of corrosion in acid solutions can be accomplished using a variety of organic compounds. Among those used for this purpose are triple-bonded hydrocarbons, acetylenic alcohols, sulfoxides, sulfides, and mercaptans; aliphatic, aromatic, or heterocyclic compounds containing nitrogen; and many other families of simple organic compounds and of condensation products formed by the reaction between two different species such as amines and aldehydes.

Incorrect choice or the use of organic inhibitors in acid solutions can lead to corrosion stimulation and/or hydrogen penetration into the metal. In general, stimulation of corrosion is not related to the type or structure of the organic molecule. Stimulation of iron's corrosion has been found with mercaptans, sulfoxides, azoles, and triazole derivatives, nitrites, and quinoline. This adverse action depends on the type of acid. For example, bis(4-dimethylamino-phenylantipyrilcarbinol and its derivatives at a 10^{-4} concentration inhibited attack of steel in hydrochloric acid solutions but stimulated attack in sulfuric acid solutions. Much work has been done studying the inhibiting and/or stimulating phenomena of organic compounds on ferrous as well as nonferrous metals. Organic inhibitors have a critical concentration value, below which inhibition ceases and stimulation begins. Therefore, it is essential that when organic inhibitors are used, constant monitoring of the solution should take place to ensure that the inhibitor concentration does not fall below the critical value.

It is generally assumed that the first stage in the action mechanism of inhibitors in aggressive acid media is adsorption of the inhibitors onto the metal surface. This adsorption process is influenced by the nature and surface charge of the metal, by the chemical structure of the inhibitor, and by the type of aggressive electrolyte. Physical (or electrostatic) adsorption and chemisorption are the principal types of interaction between an organic inhibitor and a metal surface.

10.3.1 Physical Adsorption

Physical adsorption is the result of electrostatic attractive forces between inhibiting organic ions or dipoles and the electrically charged surface of the metal. The surface charge of the metal is due to the electric field at the outer Helmholtz plane of the electrical double layer existing at the metal/solution interface. The surface charge can be defined by the potential of the metal (E_{corr}) vs. its zero charge potential (ZCP) ($E_{q=0}$).¹² When the difference $E_{\text{corr}} - E_{q=0} = \varnothing$ is negative, carbon adsorption is favored. Adsorption of anions is favored when \varnothing becomes positive. This behavior is related not only to compounds with formal positive or negative charge, but also to dipoles whose orientation is determined by the value of the \varnothing potential.

According to Antropov,¹⁶ at equal values of \varnothing for different metals, similar behavior of a given inhibiting species should be expected in the same environment. This has been verified for adsorption of organic charged species on mercury and iron electrodes at the same potential for both metals.

In studying the adsorption of ions at the metal/solution interface, it was first assumed that ions maintained their total charge during the adsorption, giving rise in this way to a pure electrostatic bond. Lorenz¹⁷⁻¹⁹ suggested that a partial charge is present in the adsorption of ions; in this case, a certain amount of covalent bond in the adsorption process must be considered. The partial charge concept was studied by Vetter and Schulze,²⁰⁻²² who defined as electrosorption valency the coefficient for the potential dependence and charge flow of electrosorption processes. The term "electrosorption valency" was chosen because of its analogy with the electrode reaction valency that enters into Faraday's law as well as the Nernst equation.

Considering the concepts discussed above in relation to corrosion inhibition, when an inhibited solution contains adsorbable anions, such as halide ions, these adsorb onto the metal surface by creating oriented dipoles and consequently increase the adsorption of the organic cations on the dipoles. In these cases, a positive synergistic effect arises; therefore, the degree of inhibition in the presence of both adsorbable anions and inhibitor cations is higher than the sum of the individual effects. This could explain the higher inhibition efficiency of various organic inhibitors in hydrochloric acid solutions compared to sulfuric acid solutions (see Table 10.2).

TABLE 10.2

Inhibition Efficiency of Some Pyridinium Derivatives at the Same Molar Concentration (1×10^{-4} M) on Armco Iron in Hydrochloric and Sulfuric Acid Solutions at 12°C

Additive	Inhibition Efficiency (%)	
	1 N HCl	1 N H ₂ SO ₄
n-Decylpyridinium bromide	87.6	20.0
n-Decyl-3-hydroxypyridinium bromide	94.8	57.5
n-Decyl-3-carboxypyridinium bromide	92.7	76.5
n-Decyl-3-5-dimethylpyridinium bromide	92.5	30.2

10.3.2 Chemisorption

Another type of metal/inhibitor interaction is chemisorption. This process involves charge sharing or charge transfer from the inhibitor molecules to the metal surface in order to form a coordinate type of bond.

The chemisorption process takes place more slowly than electrostatic adsorption and with a higher activation energy. It depends on the temperature, and higher degrees of inhibition should be expected at higher temperatures. Chemisorption is specific for certain metals and is not completely reversible. The bonding occurring with electron transfer clearly depends on the nature of the metal and the nature of the organic inhibitor. In fact, electron transfer is typical for metals having vacant, low-energy electron orbitals. Concerning inhibitors, electron transfer can be expected with compounds having relatively loosely bound electrons. This situation may arise because of the presence in the adsorbed inhibitor of multiple bonds or aromatic rings, whose electrons have π character. Clearly, even the presence of heteroatoms with one lone pair of electrons in the adsorbed molecule will favor electron transfer. Most organic inhibitors are substances with at least one functional group regarded as the reaction center for the chemisorption process. In this case, the strength of the adsorption bond is related to the heteroatom electron density and to the functional group polarizability. For example, the inhibition efficiency of a homologous series of organic substances differing only in the heteroatom is usually in the following sequence:

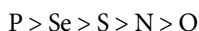

An interpretation may be found in the easier polarizability and lower electronegativity of the elements on the left in the above sequence. On this basis, a surface bond of a Lewis acid-base type, normally with the inhibitor as the electron donor and the metal as the electron acceptor, has been postulated.

10.3.3 Interactions between Adsorbed Inhibitors

When the coverage of the metal surface by the adsorbed inhibitor species increases, lateral reactions between inhibitor molecules may arise, thereby influencing efficiency.

Attractive lateral interactions usually give rise to stronger adsorption and higher inhibition efficiency. This effect has been shown in the case of compounds containing long hydrocarbon chains, because of attractive van der Waals forces. In the presence of ions or molecules containing dipoles, repulsive attractions may occur, thus weakening the adsorption and diminishing the inhibition efficiency.

10.3.4 Relationships between Inhibitor Reactivity and Efficiency

The nature of the inhibitor initially present in acid solutions may change with time and/or electrode potential as a consequence of reduction reactions, polymerization reactions, or the formation of surface products. The inhibition because of the reaction products is usually called secondary inhibition, whereas primary inhibition is attributed to the compound initially added to the solution. Secondary inhibition may be higher or lower than primary inhibition, depending on the effectiveness of the reaction products.

An example of inhibitors undergoing electrochemical reduction is that of sulfoxides, the most important being dibenzyl sulfoxide, whose reduction gives rise to a sulfide that is more effective than the primary compound.

On the contrary, the reduction of thiourea and its alkyl derivatives gives rise to HS^- ions, whose accelerating effect is known. In some instances, the reduction reaction may be followed by polymerization reactions at the metal/electrolyte interface. This mechanism of action is generally accepted for acetylenic derivatives. Electrochemical measurements on iron electrodes in sulfuric acid solutions inhibited by alkynes showed that acetylenic compounds act as cathodic inhibitors, giving rise to a surface barrier phenomenon. Duwell et al.²⁴ found hydrogenation and dehydration reaction products in heptane extracts of acid/iron powder/ethynylcyclohexan-1-ol. According to Duwell et al., the efficiency of ethynylcyclohexan-1-ol as a corrosion inhibitor apparently depends on the properties and rates of formation of the reaction products.

10.4 Inhibition of Near-Neutral Solutions

Because of the differences in the mechanisms of the corrosion process between acid and near-neutral solutions, the inhibitors used in acid solutions usually have little or no inhibition effect in near-neutral solutions. In acid solutions, the inhibition action is due to adsorption on oxide-free metal surfaces. In these media, the main cathodic process is hydrogen evolution.

In most neutral solutions, the corrosion process of metals results in the formation of sparingly soluble products, such as oxides, hydroxides, or salts. The cathodic partial reaction is oxygen reduction.

Inorganic or organic compounds as well as chelating agents are used as inhibitors in near-neutral aqueous solutions. Inorganic inhibitors can be classified according to their mechanisms of action:

1. Formation and maintenance of protective films can be accomplished by the addition of inorganic anions such as polyphosphates, phosphates, silicates, and borates.
2. Oxidizing inhibitors, such as chromates and nitrites, cause self-passivation of the metallic material. It is essential that the concentration of these inhibitors be maintained above a "safe" level. If not, severe corrosion can occur as a result of pitting or localized attack caused by an oxidizer.
3. Precipitation of carbonates on the metal surfaces forming a protective film. This usually occurs because of the presence of Ca^{2+} and Mg^{2+} ions usually present in industrial waters.
4. Modification of protective film properties is accomplished by the addition of Ni^{2+} , Co^{2+} , Zn^{2+} , or Fe^{2+} .

The sodium salts of organic acids such as benzoate, salicylate, cinnamate, tartrate, and azelate can be used as alternatives to the inorganic inhibitors, particularly in ferrous solutions. When using these particular compounds in solutions containing certain ions such as chlorides or sulfates, the inhibitor concentration necessary for effective protection will depend on the concentration of the aggressive anions. Therefore, the critical pH value for inhibition rather than the critical concentration must be considered. Other formulations for organic inhibition of near-neutral solutions are shown in the following table:

Organic Inhibitors for Use in Near-Neutral Solutions

Inhibitor	Type of Metal Protected
Organic phosphorus-containing compounds, salts of aminomethylenephosphoric acid, hydroxyethylidenediphosphoric acid, phosphenocarboxylic acid polyacrylate, poly-methacrylate	Ferrous
Borate or nitrocinnamate anions (dissolved oxygen in solution required)	Zinc, zinc alloys
Acetate or benzoate anions	Aluminum
Heterocyclic compounds such as benzotriazole and its derivatives, 2-mercaptobenzothiazole, 2-mercaptobenzimidazole	Copper, copper-based alloys

Chelating agents of the surface-active variety also act as efficient corrosion inhibitors when insoluble surface chelates are formed. Various surface-active chelates recommended for corrosion inhibition of different metals are shown below.

Chelating agents used as corrosion inhibitors in near-neutral solutions include:

Chelating Agent	Type of Metal Protected
Alkyl-catechol derivatives, sarcosine derivatives, carboxymethylated fatty amines, and mercaptocarboxylic acids	Steel in industrial cooling systems
Azo compounds, cupferron, and rubeanic acid	Aluminum alloys
Azo derivatives and alkyl esters of thioglycolic acid	Zinc and galvanized steel
Oximes and quinoline derivatives	Copper
Cresolphthalexon and thymolphthalexon derivatives	Titanium in sulfuric acid solutions

10.5 Inhibition of Alkaline Solutions

All metals whose hydroxides are amphoteric and metals covered by protective oxides that are broken in the presence of alkalis are subject to caustic attack. Localized attack may also occur as a result of pitting and crevice formation.

Organic substances such as tannions, gelatin, and agar-agar are often used as inhibitors for the protection of aluminum, zinc, copper, and iron. Other materials also found effective include thiourea, substituted phenols, β -diketones, 8-hydroxyquinoline, and quinalizarin.

10.6 Temporary Protection with Inhibitors

Occasions arise when temporary protection of metallic surfaces against atmospheric corrosion is required. Typical instances are in the case of finished metallic materials or of machinery parts during transportation and/or storage prior to use. When ready for use, the surface treatment or protective layer can be easily removed.

It is also possible to provide protection by controlling the aggressive gases or by introducing a vapor-phase inhibitor. This latter procedure can only be

accomplished in a closed environment such as sealed containers, museum showcases, or silmair enclosures.

Organic substances used as contact inhibitors or vapor inhibitors are compounds belonging to the following classes:

1. Aliphatic, cycloaliphatic, aromatic, and hetrocylic amines
2. Amine salts with carbonic, carbamic, acetic, benzoic, nitrous, and chromic acids
3. Organic esters
4. Nitro derivatives
5. Acetylenic alcohol

10.7 Inhibition of Localized Corrosion

Corrosion inhibitors are usually able to prevent general corrosion but their effect on localized corrosion processes is limited. Generally, a higher inhibitor concentration is required to prevent localized corrosion processes than is necessary to inhibit general corrosion.

Staehe²⁵ examined the possibility of inhibiting localized attack that does not depend on metallurgical structures. He considered phenomena related to:

- Geometric effects, such as galvanic corrosion and crevice corrosion
- Simple localization of the attack, such as pitting and dezincification
- Effects of relative motion, such as erosion and cavitation

The application of organic inhibitors to control galvanic corrosion presents several problems. It is well known that an inhibitive treatment efficient on a single metal, because of the specific action of the inhibitor, may fail to control corrosion if dissimilar metals are in contact. The behavior of a zinc-steel couple in sodium benzoate solution was studied by Brasher and Mercer.²⁶ Steel is protected in benzoate solution but usually it corrodes when coupled to zinc, as in galvanized iron, in that solution. An interpretation of the phenomena was given, emphasizing that rusting of steel coupled to zinc in benzoate solution can be prevented by bubbling air through the solution for 1 or 2 days immediately after immersion. After this time, the system should have become stabilized and no corrosion of the steel should take place when the air stream is discontinued. In the study of the steel-copper combination in a hot-water system, the best inhibitor efficiency was obtained using a mixture of benzoate and nitrite.

It is well known that pitting depends not only on the concentration of the aggressive anions in the solution, but also on the concentration of the nonaggressive anions. For this reason, special attention must be paid to the effect of inhibitor anions in the aggressive solution. The presence of nonaggressive anions produces different effects:

1. Shifting the pitting potential to more positive values
2. Increasing the induction period for pitting
3. Reducing the number of pits

It has been found that pit nucleation on iron electrodes in phthalate buffer containing chloride ions was prevented by pictate ions. The pitting potential of iron in borate buffer containing chloride ions is enhanced by the presence of capronate. On the other hand, sulfate ions can reduce the current density at the pit bottom area, inhibiting the propagation stage of pitting corrosion.

Dezincification is the most common example of selective leaching. It is usually prevented by using less-susceptible alloys. The phenomenon can also be minimized by reducing the aggressive of the environment with corrosion inhibitors. The addition of surface-active substances such as saponin, dextrin, or benzotriazole can inhibit dezincification of single-phase and dibasic brass in 0.5 N NaCl and HCl solutions. The highest inhibition efficiency was obtained by benzotriazole.

Mild steels are susceptible to SCC in nitrate, caustic, and carbonate solutions. It has been demonstrated that the presence of inorganic ions (e.g., nitrate or chromate) or organic chemicals (e.g., acetate, benzoate) can inhibit the localized attack.

Research on SCC inhibition with austenitic stainless steels in magnesium chloride solutions has been performed by Lee and Uhlig²⁷ and Pinard²⁸. In the presence of small concentrations of piperidine, n-decylamine, and other nitrogen-containing substances, it was possible to noticeably lengthen the failure time of AISI 304 wires under constant load in boiling chloride solutions.

The influence of some organic substances on the stress corrosion cracking of austenitic stainless steels in sulfuric acid solutions containing chlorides or in dilute hydrochloric acid solutions at room temperature has also been studied. Very promising results have been obtained with benzonitrile, 2-mercaptobenzimidazole, 2-mercaptobenzothiozole, and thiourea derivatives, depending on the type of aggressive medium. The overall results support the idea that SCC of austenitic stainless steels in acid chloride media occurs on the alloys in the active state and is related to the presence of an adsorbed layer of chloride ions. The stress brings "bare" metal areas, which are more active than the surrounding areas, into contact with the solution. A very localized attack can thus occur with the consequent formation of a crack. In this way, only organic substances able to rapidly adsorb onto the surface

zones where the layer is destroyed by the mechanical stress can block the fissuring attack by inhibiting the anodic process of metal dissolution.

With regard to corrosion fatigue, there are two principal ways to mitigate the phenomenon: (1) by lowering the stress amplitude or (2) by reducing the corrosivity of the medium. The latter can be achieved by varying pH, decreasing temperature, or adding inhibitors.

10.8 Summary

Corrosion inhibitors are usually able to prevent general or uniform corrosion. However, they are very limited in their ability to prevent localized corrosion such as pitting, crevice corrosion, galvanic corrosion, or stress corrosion cracking. Additional research work is being undertaken in the use of inhibitors to prevent these types of corrosion. The importance of these studies is realized when it is taken into account that only about 30% of all failures because of corrosion in chemical plants result from general corrosion. The remaining 70% is due to stress corrosion cracking, corrosion fatigue, and erosion corrosion. Attack on metals by general corrosion can be predicted and life spans of the equipment determined and/or the corrosion rates reduced by the use of inhibitors. This is not the case with other types of corrosion.

The use of inhibitors can be advantageous in certain cases. However, before using inhibitors, it is essential that the efficiency of the inhibitor to be used be determined to ensure that inhibition will take place.

References

1. TrabANELLI, G. and Carassiti, V., 1970, *Advances in Corrosion Science and Technology*, Fontana, M.G. and Staehle, R.W., Eds., Vol. 1, New York: Plenum Press, p. 147–229.
2. Foroulis, Z.H., 1969, *Proc. Symp. Basic and Applied Corrosion Research*, Houston: NACE International.
3. Riggs, Jr., O.L., 1973, *Corrosion Inhibitors*, Nathan, G.C., Ed., Houston: NACE International, p. 7.
4. Thomas, J.C., 1976, *Corrosion*, Shreir, J.L., Ed., Vol. 2, London: Newnes Butterworths, p. 183.
5. McCafferty, E., 1979, *Corrosion Control by Coatings*, Leidheiser, H., Ed., Princeton, NJ: Science Press, p. 279.
6. Rosenfield, J.L., 1981, *Corrosion Inhibitors*, New York: McGraw-Hill.
7. Fisher, H., 1972, *Werkst. Korros*, 23: 444–465.

8. Lorenz, W.J. and Mansfield, F., 1983, *Int. Conf. Corrosion Inhibition*, National Association of Corrosion Engineers, Dallas, Paper 2.
9. Lorenz, W.J. and Mansfield, F., 1980, *31st ISE Meeting*, Venice.
10. Lorbeer, P. and Lorenz, W.J., 1980, *Electrochim. Acta*, 25: 375.
11. Hausler, R.H., 1983, *Int. Conf. Corrosion Inhibition*, National Association of Corrosion Engineers, Dallas, Paper 19.
12. Uhlig, H. and King Jr., P., 1959, *J. Electrochem. Soc.*, 106: 1.
13. Powers, R. and Hacherman, N., 1953, *J. Electrochem. Soc.*, 100: 314.
14. Cohen, M. and Beck, A., 1958, *Z. Electrochem.*, 62: 696.
15. Brasher, D. and Kingsbury, A., 1958, *Trans. Faraday Soc.*, 54: 1214.
16. Antropov, L.I., 1962, *First Int. Congr. Metallic Corrosion*, London: Butterworths, p. 147.
17. Lorenz, W., 1962, *Z. Physik. Chemie*, 219: 421.
18. W. Lorenz, 1963, *Z. Physik. Chemie*, 224: 145.
19. Lorenz, W., 1970, *Z. Physik. Chemie*, 244: 65.
20. (a) Vetter, K.L. and Schulze, J.W., 1972, *Ber. Bunseng. Physik. Chemie*, 76: 920; (b) Vetter K.L. and Schulze, J.W., 1972, *Ber. Bunseng. Physik. Chemie*, 76: 927.
21. Schulze, G.W. and Vetter, K.L., 1973, *Z. Electroanalyt. Chem. Interfac. Electrochem.*, 44: 68.
22. Vetter, K.L. and Schulze, G.W., 1974, *J. Electroanalyt. Chem. Interfac. Chem.* 53: 67.
23. (a) Schulze, J.W. and Koppitz, K.D., 1976, *Electrochim. Acta*, 21: 327. (b) Schulze, J.W. and Koppitz, K.D., 1976, *Electrochim. Acta*, 21: 337.
24. Duwell, E.J., Todd, J.W., and Butzke, H.C., 1964, *Corrosion Sci.*, 4: 435.
25. Staehl, R.W., 1975, *Proc. 4th Eur. Symp. Corrosion Inhibitors*, Ann. Univ., Ferrara, N.S. Sez. V. Suppl. 6, 709.
26. Brasher, D.M. and Mercer, A.D., 1969, *Proc. 3rd Int. Congr. Metallic Corrosion*, Vol. 2, Moscow: MIR, p. 21.
27. Lee, H.H. and Uhlig, H., 1970, *J. Electrochem. Soc.*, 117: 18.
28. Pinard, L., 1972, *Mem. Sci. Rev. Meta.*, 69: 425.

11

The Equipment Design Process

Most engineers, at some point in their careers, are faced with the problem of selecting a material of construction for a specific project or application. This applies equally to mechanical, civil, chemical, aeronautical, or any other engineering or related discipline.

In most cases the selection process requires that the engineer must refer to more than one engineering discipline in order to select the most suitable material of construction. For example, chemical engineers must be aware of the mechanical properties of materials, as must structural engineers, while both must be aware of the corrosion-resistant properties of materials — and so with other engineering disciplines.

It is the purpose of this chapter to point out the various considerations that must be taken into account, with primary emphasis being placed on corrosion resistance.

11.1 Understanding the Application

Before any consideration can be given to the selection of a material of construction, there must be a thorough understanding of the application.

If the application is a structure, whether it be a tower, bridge, or building, it is important that the location be defined because it will be subject to atmospheric corrosion.

Because atmospheric corrosion rates are affected by local conditions, atmospheres are classified according to exposure conditions. The major categories, based on potential corrosion rates, are:

- Rural
- Urban
- Industrial
- Marine
- Indoor

The first four categories can be further subdivided into arctic, temperate, and tropical (wet or dry) because the differences in temperature, humidity, and

seawater composition all have a bearing on the corrosion rates. However, we are primarily concerned with conditions in the temperate category. But keep in mind that in the southern sections of the temperate zone, ambient temperatures may be relatively high, which can have an effect on corrosion rates.

A rural atmosphere is generally that of an inland farm with little or no heavy manufacturing operations. In such areas, the problems of atmospheric corrosion will be somewhat diminished. The same will apply in very dry climatic conditions.

Urban atmospheres, even when free from industrial pollution, are subject to pollution from road traffic and the burning of fossil fuels. The former produces oxides of nitrogen, which may be oxidized to nitric acid. The latter has the potential of generating sulfur dioxide, which is converted to sulfuric and sulfurous acid in the presence of moisture.

In an industrial atmosphere, all types of contamination by sulfur in the form of sulfur dioxide or hydrogen sulfide are important. The burning of fossil fuels generates a large amount of sulfur dioxide, which is converted to sulfuric and sulfurous acids in the presence of moisture. Combustion of these fossil fuels and hazardous waste products should produce only carbon dioxide, water vapor, and inert gas combustion products. This is seldom the case. Depending on the impurities contained in the fossil fuel, the chemical composition of the hazardous waste materials incinerated, and the combustion conditions encountered, a multitude of other compounds may be formed.

In addition to the most common contaminants previously mentioned, pollutants such as hydrogen chloride, chlorine, hydrogen fluoride, and hydrogen bromide are produced as combustion products from the burning of chemical waste. When organophosphorous compounds are incinerated, corrosive phosphorous compounds are produced. Chlorides are also a product of municipal waste incinerators.

Energy production leads to the formation of oxides of nitrogen, which may be oxidized to nitric acid. This reaction has a very low rate; therefore, in the vicinity of the emission source, the concentration of nitric acid and nitrites is very low. The greatest effect will occur at some distance from the emission source.

The antipollution regulations that have been enacted do not prevent the escape into the atmosphere of quantities of these materials sufficient to prevent corrosion problems. The corrosivity of an industrial atmosphere diminishes with increasing distance from the area.

Marine environments are subject to chloride attack resulting from the deposition of droplets of crystals formed by evaporation of spray that has been carried by the wind from the sea. The quantity of chloride depositions from a marine environment is directly proportional to the distance from the shore — the closer to the shore, the greater the deposition and corrosive effect. The atmospheric test station at Kure Beach, North Carolina, shows that steel exposed 80 ft from the ocean corrodes 10 to 15 times faster than steel exposed 800 ft from the ocean. The distance from the shore at which marine atmospheres cease depends on the prevailing winds, the distance

they travel over at speed, and the height of the local surf. Mixtures of marine and industrial effects are common in many areas, with each type of contaminant aggravating the other.

In addition to these general air contaminants, there may also be specific pollutants found in a localized area. These may be emitted from a manufacturing operation on a continuous or spasmodic basis and can result in a much more serious corrosion problem than that caused by the presence of general atmospheric pollutants.

Because of these varying conditions, a material that is resistant to atmospheric corrosion in one area might not be satisfactory in another area. For example, galvanized iron is perfectly suitable for application in a rural atmosphere but is not suitable when exposed to industrial atmospheres.

To compound the problem, there is no clear line of demarcation between these atmospheric types. In many cases, there is no "pure" rural or urban area. Contamination from industrial or marine areas may find its way into these areas based on the prevailing winds and other atmospheric conditions.

Indoor atmospheres may be free of corrosion in "clean rooms" or subject to severe corrosion, as around a pickling bath in a steel mill.

Atmospheric conditions should be defined in terms of temperature, humidity, and contaminants, as well as their corrosivity to the specific materials of construction being considered. In addition to the general atmospheric conditions, special conditions such as cooling tower drift or spray, spills, or releases of water or chemicals should not be overlooked and must be taken into account.

If the application is a process vessel, storage tank, or pipeline, the following information must be known about the process and/or the material being handled:

1. What are the primary chemicals being handled? And at what concentrations?
2. Are there any secondary chemicals? And if so, at what concentrations?
3. Are there any trace impurities or chemicals?
4. Are there any solids present? And if so, what are their particle sizes and concentrations?
5. If a vessel, will there be agitation? And if so, to what degree? If a pipeline, what are the flow rates (maximum and minimum)?
6. What are the fluid purity requirements?

The answers to the above questions will narrow the selection to those materials that are compatible. The next set of questions will narrow the selection further by eliminating materials that do not have the required physical and/or mechanical properties required:

1. What is the normal operating temperature and temperature range?
2. What peak temperatures can be reached during shutdown, startup, process upset, etc.?
3. Will any mixing areas exist where exothermic or heat-of-mixing temperatures can develop?
4. What is the normal operating pressure?
5. What vacuum conditions and range are possible during operation, startup, shutdown, or upset conditions?
6. Will there be temperature cycling?
7. What cleaning methods will be used?

Finally, consideration should be given the conditions external to the vessel or pipe:

1. What are the ambient temperature conditions?
2. What is the maximum surface temperature during operation?
3. What are the insulation requirements?
4. What is the nature of the external environment? This can dictate finish requirements and/or affect the selection of the shell material.
5. What are the external heating requirements?
6. Is grounding necessary?

With the answers to these questions, an appropriate selection of a material of construction can be made.

11.2 Selecting Materials of Construction

Although cost is a consideration in the selection of materials, it should not necessarily be considered in the first cut of materials that can be eliminated from consideration. The cost factor must be considered but only after the list of materials that fulfill the other requirements has been narrowed for technical reasons. There are several ways to approach the elimination process. Following is a suggested format. The actual format will depend on the requirements for each specific application.

1. *Temperature.* For an application requiring elevated temperature usage, there is no point in considering low-melting-point metals, polymers, or polymer composites. For operating temperatures above 932°F (500°C), the list of potential materials can be greatly reduced. On the

- other hand, with an operating temperature in the ambient zone, the selection process becomes more complicated because of the greater number of potential materials that will meet the requirements.
2. *Stress.* Once the operating range of usage has been established, stress and ductility are the next most prominent mechanical properties that must be considered. Here, the first decision that must be made is whether we are dealing with yield or ultimate strengths and whether these strengths should be those determined in tension, torsion, or compression.
 3. *Ductility.* The ductility is usually taken into consideration at the same time that the stress requirements are being evaluated because, in general, the higher the strength, the lower the ductility of the material. If both properties are important, some compromises must be made.
 4. *Toughness.* The fracture toughness must be considered in addition to the ductility, particularly if shock loading is believed to be an operating condition. If it is not known whether shock, or impact loading, could occur, then err on the conservative side.
 5. *Modulus of elasticity.* The modulus is an important design parameter, and where weight is a consideration, the specific modulus is a more useful number. It must be realized that the inherent modulus of a material cannot be altered without changing its composition. For metals, the modulus of a soft metal is identical to that of the same strain-hardened metal. The moduli of polymers are very small and not well defined. Perhaps the composites are the only materials that can be designed to a desired modulus. Ceramics have the highest moduli of all groups because of their strong covalent-ionic bonds.
 6. *Physical properties.* The coefficient of thermal expansion and the thermal and electrical conductivities are the most prominent physical properties that one must usually know. It should be kept in mind that these properties do vary with temperature, and one must select values that were determined over the temperature range of interest. Density and specific heats are physical properties that are of lesser importance, although the density must be considered in terms of the specific strength and specific modulus.
 7. *Corrosion resistance.* This is one of the most difficult and at the same time one of the most important material characteristics with which to deal. The corrosion resistances of the most often-used materials of construction to many media and environments have been compiled and discussed in various publications. One such compilation is *Corrosion Resistance Tables* of metals, nonmetals, coatings, linings, plastics, elastomers, and fabrics by Philip A. Schweitzer (published by Marcel Dekker). It contains data on 874 corrodents. Another book

covering the subject is the *Corrosion Engineering Handbook* by Philip A. Schweitzer (published by CRC Press).

From the above sources, or from manufacturers' data sheets, the corrosion rate for uniform corrosion can be determined. This will enable the engineer to determine the amount of material that will be lost over the required life of the equipment, thereby permitting a corrosion allowance to be established.

8. *Economic considerations.* Typically at this point, the viable alternatives can easily be reduced to a handful of materials, often two or three. Economics is often the basis for making the final selection. However, making the choice on the basis of minimum material costs is not always the best overall economic alternative. Other factors that must be considered are:
 - a. *Fabrication costs*, including the cost of making the equipment, transportation to the job site, and the installation. Some of the cost differences may be subtle. For example, carbon steel may not require postweld heat treatment but 1/4 Cr-1/2 Mo alloy might. Thus, the cost differences would be greater than the differences between the cost of the two alloys.
 - b. *Maintenance costs*, including a judgment about how frequently the equipment will need to be inspected for corrosion damage.
 - c. *Fouling* can be a problem where there are large surface areas of materials with an otherwise acceptable corrosion rate. For example, a large tower packed with steel packing may generate tons of corrosion product even when the corrosion rate is moderate. This corrosion product can foul the small passages through the packing and plug downstream heat exchangers and other equipment.
 - d. *Reliability requirements.* Some equipment may require a high level of reliability. This would be the case for equipment with a long delivery time and where spare equipment cannot be held in inventory. Conversely, less conservative material choices can be made if spare equipment is available and having an equipment failure does not create a serious safety or environmental event.
 - e. *Repair costs*, including judgments about how easily and quickly the equipment can be repaired. Will major components have to be replaced rather than repaired?
 - f. *Cost of lost production* due to equipment inspection, repair, or replacement must be considered.

Although it may be difficult to do with high levels of confidence, these judgments can be reduced to dollar estimates. NACE Standard RP-02-72 Recommended Practice — Direct Calculation of Economic Appraisals of Corrosion Control Measures provides

a standard method for economic appraisals of materials alternatives. This method takes into consideration the various costs and evaluates them in light of the time value of money and the effects of taxes and similar events. It should be used as a checklist to ensure that all relevant factors are considered.

- g. *Final selection.* With the information from the above analysis, it is now possible to make a materials selection with confidence that the relevant factors have been considered. Often it is desirable to select a second or even a third alternative material so that quick adjustments can be made in the case of material shortages.

11.3 Controlling Corrosion by Design

It is impossible to completely eliminate corrosion, but it is possible to control the corrosion rate and thereby keep it within tolerable limits, as discussed in previous chapters.

Severe destruction of plant material can result when improper materials are selected for a particular environment. Inspection and early corrective action can result in major savings to plants and their facilities.

Consideration must be given to the design after facilities are placed in operation. Operating personnel should monitor the condition of the piping and equipment by nondestructive testing after an operating period. If these on-stream and off-stream inspections indicate a potentially unsatisfactory lifetime or a threat to the integrity of the equipment and plant, determining the corrosion mechanism can be a guide to the solution. Rating tables for the various metals and alloys, plastic materials, elastomers, coatings, or linings can lead to improved performance.

In Chapter 3 the various forms of corrosion were discussed, which frequently can be prevented and or controlled by proper material selection and/or appropriate design practices, and if specific in-plant procedures are followed. For example, in the design of tankage, it is possible to eliminate crevice corrosion by proper design. The use of butt welds is preferable to lap welds. In addition, the use of butt welds is especially suitable for tank lining applications. If lap welds are used, the laps should be filled with fillet welding or a suitable caulking compound to prevent crevice corrosion.

11.3.1 Protection from Atmospheric Corrosion

When proper decisions are made at the design stage, many corrosion problems can be reduced or eliminated. It is better to reduce the possibilities of corrosion in the beginning than to take elaborate steps later for the prevention of corrosion. A design engineer is not necessarily a corrosion engineer

but he/she should be aware of the factors that aggravate atmospheric corrosion so as to be in a position to guard against them.

The potential for the degradation of materials resulting from atmospheric corrosion is always present. General factors that are responsible for atmospheric corrosion are relative humidity, average temperature and temperature range, pollutant concentration, suspended dust particles, and total time of wetness. These factors are always present and should be guarded against as much as possible during the design stage because these factors themselves cannot be controlled.

Because of increased concern about the environment, the atmosphere is generally less polluted today than it was several years ago. However, industrial pollution still exists in sufficient concentrations to cause degradation of materials. Industrial pollution exists in rural atmospheres that may also have routinely high humidities. In other areas, mixtures of marine and industrial pollutants are common, with each type of contaminant aggravating the other. Prevailing winds will determine the distance from the shore that marine atmospheres will be found. All these factors must be considered during the early design stages.

The time of wetness must also be taken into account. Geographic location plays a part in the total time of wetness because the total time of wetness is affected by rain, fog, dew, snow, and dust as well as temperature.

Location is the first factor that must be considered before the design is started. This determines the type of area, whether it be rural, urban, industrial, marine, or a combination thereof. Theoretically, each of these atmospheric types is indicative of specific degrees and types of atmospheric contaminants. However, for all practical purposes, this does not hold true because there is no sharp distinction between the atmospheric types. In many cases, there is no "pure" urban or rural area. Depending on prevailing winds, contamination from industrial or marine areas might find its way into urban or rural areas. Because of this, it is a good policy to analyze samples from the area where the facility will be located. The atmospheric conditions of the area should be defined in terms of temperature, humidity, and acid contaminants. Thought should also be given to special conditions that may exist in the area, such as location of stacks, cooling tower drift or spray, spills, release of water or chemicals, or other abnormal conditions.

Proper maintenance programs, frequency of inspections, and economics of upkeep should also be considered. These items will assist in selecting the proper material of construction and/or protective measures.

11.3.1.1 General Design Considerations

The mechanisms of atmospheric corrosion were discussed in previous chapters for various materials of construction. This chapter deals with other aspects of the prevention and control of atmospheric corrosion.

Some general design rules to be used to limit the effect of atmospheric corrosion are as follows:

1. *Avoid crevices.* Crevices provide areas where atmospheric pollutants might collect and not be washed away by rain. The collected material will continue to react with the surface and corrode it.
2. *Avoid mechanical stresses.* Excess mechanical stresses and stress concentrations increase the potential for stress corrosion cracking.
3. *Avoid galvanic contact.* Same or similar metals should be used throughout the structure. When dissimilar metals are in contact, galvanic corrosion takes place. If the use of dissimilar metals cannot be avoided, the corroding part should be designed in such a way that it can be easily replaced. Fastening materials should be more noble.
4. *Avoid sheltering from rain.* Rain can be helpful in preventing or reducing atmospheric corrosion by washing away pollutants that have accumulated during the dry period.
5. *Provide corrosion allowance.* The full life expectancy of a structure may be ensured by increasing the mechanical design thickness of the member by an amount equivalent to what will be lost as a result of atmospheric corrosion during the lifetime of the structure.

11.3.1.2 Structures

Included under structures are many ancillary items such as ladders, grating, platforms, guardrails, and support structures. The general practice has been to use steel, galvanized iron, and aluminum for these applications. Corrosion of these items has always been a problem and has resulted in high maintenance costs.

Much time has been spent over the years to provide materials that will reduce or eliminate the problems of corrosion for these applications. These efforts have resulted in the development of glass-reinforced polyester and vinyl ester materials. At the present time there are available over 100 standard structural shapes from which platforms, supports, structures, and decking can be fabricated. These materials offer several advantages, including corrosion resistance, nonconductivity, high strength, light weight, and dimensional stability.

Three basic resins are used: (1) isophthalic polyester, which is the least expensive and is used in most general applications for which it is not necessary for the material to have fire-retardant properties; (2) isophthalic polyester with a fire-retardant additive has the same general properties and area of application as the basic isophthalic polyester resin; and (3) vinyl ester resin, which is the most expensive but has the greatest corrosion resistance, superior strength and physical properties, and is also fire retardant. These materials are resistant to most corrodents found in the atmosphere and to a

wide range of materials that may spill on the surface. Complete corrosion-resistance properties can be found in *Corrosion Resistance Tables, 5th ed.*, published by Marcel Dekker.

The glass-reinforced polyester and vinyl ester resin structures are non-conductive. As such, they are neither thermally nor electrically conductive. Consequently, they are ideally suited to be used as cable trays, utility truck booms, ladders, support structures for electrical devices and systems, and power junction boxes.

On a pound-for-pound basis, these fiber-reinforced plastic (FRP) materials are stronger than steel. Shapes have been used to form superstructures for multistory buildings and floating bridges. Joining is accomplished using fiberglass studs and nuts. The threads are standardized to be compatible with metal studs.

FRP structural shapes are very light in weight, which permits them to be easily transported, handled, and set into place. They weigh 80% less than a corresponding steel shape and 30% less than a corresponding aluminum shape.

When properly designed, these materials will not sag or creep under prolonged deformation or loading. Their coefficient of thermal expansion is slightly less than that of aluminum or wood.

Considering the foregoing properties, these materials are ideal for structural supports and decking to resist atmospheric corrosion. These shapes, handrails, decking, and such are available in color, with the color completely penetrating the material. This eliminates the need for periodic painting for protection or aesthetic reasons and greatly reduces the maintenance needs of these materials compared to those of their metallic counterparts. Initial purchase price may be slightly higher than the purchase price for steel but the final installed cost, including maintenance costs, makes the total installation highly competitive with less expensive materials.

Typical uses for FRP materials include:

- Ladders
- Handrails
- Support structures
- Walkways
- Operating platforms
- Roof supports and decking
- Pipe supports
- Stairs
- Cable trays
- Grating
- Enclosures

11.3.1.3 Electrical Components

Electrical distribution systems in most plants consist of galvanized iron or aluminum conduit and enclosures. These materials are often subject to corrosive attack from atmospheric pollutants. Alternative materials may be used to overcome this attack. It is possible to use such items as:

- Polyvinyl chloride (PVC)-coated conduit and enclosures
- FRP enclosures
- Stainless steel enclosures

Seals used in hazardous operating areas to prevent hazardous gases from entering the electrical enclosure (motor starter, disconnect switch, motor, etc.) can be used in nonhazardous areas to prevent corrosive fumes from entering the enclosures. This will reduce corrosion of the working parts.

Regardless of which material is used, enclosures and conduits should be located so that

- Free drainage can occur.
- Places where dirt and water can accumulate are eliminated.

This will help prevent corrosion by reducing the time of wetness.

11.3.1.4 Control Rooms

Most power plants and facilities contain control rooms, electric motor control centers, instrument control rooms, and computer centers. These are usually maintained under a slight positive pressure with make-up air being introduced with air from the outside. In many instances it is possible for this air to be contaminated with atmospheric pollutants such as sulfur oxides, hydrogen chloride, chlorides, hydrogen sulfide, dust, and other contaminants. These gases and dusts can cause serious damage to sensitive circuitry found in computers, microprocessors, microswitches, and other delicate electronic equipment. If corrosive gases are removed from these make-up streams, costly maintenance and downtime will be prevented.

The removal of these gases and particulate matter from the make-up air stream is strongly advised. It can be accomplished by treating incoming air streams in the following manner:

1. Install a filter, with a rating of approximately 25 to 30% ASHRE on the fan inlet.
2. On the discharge side of the fan, pass the air through an activated carbon bed, ensuring that the carbon bed is designed to remove the particular gases and or vapors present.

3. After the carbon bed, pass the treated air through a final filter to remove the micrometer-sized particulates.

Many older control rooms and motor control centers cannot be maintained under positive pressure because of air leakage and the inability to limit access. Under these conditions, an installation similar to the aforementioned can be incorporated on a recirculating and make-up air system.

When these systems are designed, care must be taken in the selection of the construction materials for the various components and to make sure that they are compatible with the corrodents to be encountered. Installations of this type greatly reduce maintenance costs and downtime on control equipment and electrical components.

11.3.1.5 Protection of Carbon Steel

Carbon steel is the most widely used material of construction. It is the primary choice for bridges, towers, various types of structures, and other types of outdoor construction. In nature, iron is found in the form of various oxides, which are used as ores for refining to make steel. Steels in atmospheric service therefore tend to return to their oxide form by the process known as rusting. The rusting of steel is the most common form of corrosion that the general public sees, but it is very complex, having over a dozen variables determining the rate of corrosion. Water is the most common corrosive solvent.

Atmospheric corrosion of steel is a function of location. In country air, the products of corrosion are either oxides or carbonates; in an industrial atmosphere, sulfuric acid is present, producing iron sulfate; and near the ocean, some salt is in the air, producing iron chlorides. Corrosion takes place more rapidly in industrial areas because of the presence of the acid, and it is higher both near cities and near the ocean because of the higher electrical conductivity of the rain and the tendency to form soluble chlorides or sulfates, which cause the removal of protective scale.

Except in the most innocuous atmospheres, iron and steel must be protected from corrosion by one of several means. Temporary rust preventatives, galvanizing, painting, or other protective coatings may be employed, depending on the severity of the atmosphere.

Weathering steels, such as ASTM standards A-242 and A-588, are low-alloy steels of relatively high strength that form self-protecting rust films when exposed to many industrial as well as uncontaminated atmospheres. The steels contain small amounts of copper, nickel, phosphorus, silicon, manganese, or various combinations thereof that impart corrosion resistance.

The corrosion resistance of these steels depends on the climatic conditions, pollution levels, degree of sheltering from the atmosphere, and specific composition of the steel.

Under exposure to most atmospheres, the corrosion rate becomes stabilized within 3 to 5 years. A dark brown to violet patina or protective film forms during this period. This patina is a rust formation that tightly adheres to the surface and cannot be wiped off. In rural areas with little or no pollution, a longer period may be required to form this protective film. In areas that are highly polluted with SO₂, the weathering steels exhibit a much higher corrosion rate and the formation of loose particles of rust. Under these conditions, the film provides little or no protection.

These steels do not form this protective film in marine environments where chlorides are present. Corrosion rates will be as high as for conventional carbon steels. Table 11.1 compares the corrosion rate of carbon steel and weathering steels in various atmospheres.

The formation of a patina depends on a series of wet and dry periods. Periods of flushing followed by periods of drying are necessary to develop the patina. In areas where the steel is sheltered from the rain, the dark patina does not form. Instead, a layer of rust in lighter color forms, which has the same effect.

Because the patina formed has a pleasant aesthetic appearance, the weathering steels can be used without the application of any protective coating of antirust paint, zinc, or aluminum. This is particularly true in urban and rural areas.

When employing these weathering steels, design consideration should be given to the elimination of possible areas where water, dirt, and corrosion products can accumulate. If pockets are present, the time of wetness will be increased, which will lead to the development of corrosive conditions. The

TABLE 11.1

Corrosion of Carbon Steels in Various Types of Atmospheres

Atmosphere	Exposure Time (yrs)	Average Reduction in Thickness (mil)		
		Carbon Steel	A242 (K11510) ^a Cu-P steel	A588 (K11430) ^a Cr-V-Cu Steel
Urban industrial	3.5	3.3	1.3	1.8
	7.5	4.1	1.5	2.1
Rural	3.5	2.0	1.1	1.4
	7.5	3.0	1.3	1.5
Severe marine 2.5M/80 ft from ocean	0.5	7.2	2.2	3.8
	2.0	36.0	3.3	12.2
	3.5	57.0	—	28.7
	5.0	Destroyed	14.4	38.8

^a Weathering steels.

design should make maximum use of exposure to the weather. Sheltering from rain should be avoided.

The designer should also be aware that during the period over which the protective film is forming, rusting proceeds at a relatively high rate, during which time rusty water is produced. This rusty water may stain masonry pavements, and the like. Precautions should be taken to avoid detrimental staining effects such as coloring the masonry brown so that the staining will be obvious. The weathering steels are used primarily for bridges, buildings, structures, and guardrails.

Plain carbon steel must have some form of protection applied to guard the steel from corrosion. There are many options from which to choose and these depend on the application and the severity of the atmosphere. As with the weathering steels, sheltering should be avoided, regardless of the protective coating applied. Means of protection include painting and a variety of metallic coatings.

11.3.2 Corrosion under Insulation

A thermal insulation system consists of a thermal resistance material, a jacket to protect the insulation and the insulated item from the local environment, and a method of attaching these materials to the object being insulated. It may also include sealants and barriers to prevent moisture penetration. Moisture can harm the insulation's effectiveness and may be the most important part of the mechanism, causing corrosion under the insulation (CUI).

Some insulations, such as foam glass, have a structure to prevent moisture penetration. Other insulations, such as fiberglass, must be protected by a jacket and jacket sealant at the seams to keep out the moisture. Foam glass inherently keeps out moisture but has characteristics that may not be suitable for all insulation situations, and it is one of the most expensive insulations. The selection table provided in this chapter shows the various factors to be evaluated and the part played by corrosion in selecting the most suitable insulation.

11.3.2.1 Selecting a Suitable Insulation Material

Table 11.2 provides the procedure for determining a suitable insulation material. As the table shows, corrosion factors must be given consideration and may have decisive effects on performance, safety, and economy.

There are chemical interactions to consider:

1. Insulation material can affect the metallic insulated surface. Some insulating materials contain chlorides, or the chlorides may invade

TABLE 11.2

Selection Table for a Thermal Insulation System

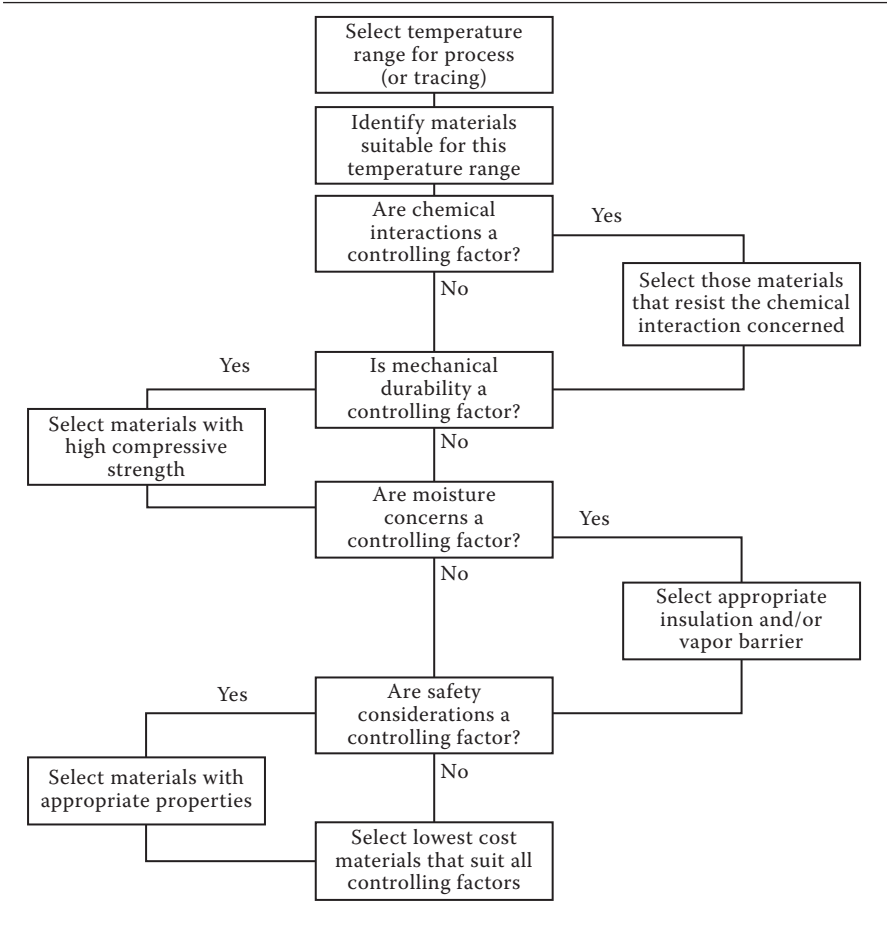

the insulation system, and chloride stress corrosion cracking of austenitic stainless alloys of piping or component can occur.

The use of a sodium silicate inhibitor in the insulation or the coating of the stainless steel is discussed in the section on design requirements. To reduce the invasion of the chloride ion, jacket and joint seals must be carefully applied. This is discussed in more detail in the section on jackets with a selection table.

To minimize chloride invasion, the mechanical durability must be considered in traffic areas on insulation jackets, vibration, or situations of mechanical and thermal shock. Materials of high compressive strength are the first choice where vehicle damage or foot traffic can be anticipated. Top heads of vessels with agitators require consideration.

Similarly, high-pressure steam lines, which typically require frequent inspection, are subject to associated foot traffic.

2. Process contents in the equipment can deteriorate insulation. Nearly all insulations are attacked by strong acid and alkali.
3. Moisture attack is another cause of deterioration of insulation. In cold service, insulation can be used to maintain the jacket outer surface at a temperature above the dew point. This prevents wetting of the insulation, which could cause it to deteriorate and become ineffective. It also prevents sweating and dripping, with resulting housekeeping problems.

Section 11.3.2.4 provides specific design information for low-temperature systems.

Absorptive-type insulation materials (e.g., fiberglass, mineral wool, calcium silicate, etc.) will initiate corrosion on the underlying metal surfaces. Alternate wet and dry cycles will produce corrosion of carbon steel and chloride stress corrosion of austenitic stainless steel. To ensure against corrosion under insulation, nonabsorptive insulation materials should be considered. These insulation characteristics are detailed later. Coating systems applied before insulation can also protect the metallic surfaces.

For elevated temperature service, the vapor barrier must be sufficiently permeable to vent moisture vapor yet resist passage of liquid water. For low-temperature service, moisture in all forms must be excluded by an impermeable vapor barrier, and that barrier must be mechanically durable. A possible exception to this rule is when cellular glass, which is itself relatively permeable, is the insulating material. However, in this case, the joints must be sealed with the right barrier using appropriate procedures.

11.3.2.2 Design Characteristics of Insulation

The selection table guides the user through the decision-making process. The properties that influence the insulation's ability to resist corrosion are moisture absorption and compressibility. These properties are given for the different types of commercial insulation. As these are typical values, manufacturers are advised to provide such ratings for the latest developments in their products.

Abbreviations used in the text discussion to identify properties of insulations are as follows:

CaSi	Calcium silicate
ExPe	Expanded perlite
GIFi	Glass fiber
MiFi	Mineral fiber or wool

UrFo	Urethane foam
CeGl	Cellular glass
FIEl	Flexible elastomer
MeAm	Melamine

The characteristics for the different types and classes of insulations are discussed for each insulation and the recommended uses are discussed in the following paragraphs.

1. *CaSi: calcium silicate (granular insulation):*

Its ability to withstand high temperature (up to 1200°F), coupled with its mechanical properties, makes CaSi a suitable choice for steam, condensate, and hot water services. It is not recommended for use in flammable liquid services due to its very high absorptivity.

CaSi has good mechanical strength, making it suitable for selection where mechanical durability is a consideration. It can withstand vibration and mechanical/thermal shock.

It is very highly absorptive and can promote corrosion of carbon steel surfaces. Additionally, the absorbing of water may prevent its selection in wet environments or wash-down areas. Once water gets into a jacketed CaSi system, it is difficult — if not impossible — to free moisture from the insulation. It is not normally recommended for use on underground piping, nor is it recommended for use over austenitic stainless steels or in areas where chlorides may invade the insulation system.

CaSi always contains a certain amount of water, most of which can be driven off in services over 250°F. This water vapor driven out of the insulation, however, may condense and dissolve alkaline chemicals in the outer part of the insulation. This can cause hidden corrosion in aluminum jacketing. For this reason and due to its high absorptivity in general, aluminum jackets used with CaSi should be specified with a moisture barrier on the inside. This barrier may be either a coating or treated kraft paper.

To prevent moisture recycle in the insulation, it is recommended that the insulation temperature be maintained above 212°F.

CaSi's K factor (or conductivity) compares favorably with other types of insulation materials at temperatures of 300°C (572°F) or higher. If it absorbs water, however, the K factor greatly increases and lowers the effectiveness of the insulation.

2. *ExPe: expanded perlite (granular insulation):*

Some of ExPe's properties (e.g., thermal conductivity, density, and compressive strength) and service characteristics are similar to those of CaSi, and it is suitable for hot services (up to 1200°F). While not quite as strong as CaSi, it has good mechanical strength,

which makes it suitable for selection where mechanical durability is a consideration. It can withstand vibration and mechanical/thermal shock.

ExPe is only slightly absorptive and does not promote corrosion of carbon steel surfaces. Suppliers should advise if properties are retained after being subject to operating conditions. It retains its modest absorptive properties for temperatures up to 600°F. However, proper moisture barriers and jacketing are still important, especially when used in flammable liquid services, wet climates, wash-down areas, and areas susceptible to leaking. Its high silica content makes ExPe suitable over austenitic stainless steels in areas where chlorides may invade the insulation system.

3. *GIFi: glass fiber (fibrous insulation):*

Its wide temperature range of -20 to 1200°F makes it suitable for use in some cold services, some high-temperature services, and some dual temperature services. When used in cold services, it requires a vapor barrier.

GIFi has low compressive strength and is susceptible to damage. It should not be used in heavily trafficked areas. It is suitable, however, for use in vibrating service. It is highly absorptive and can promote corrosion of carbon steel surfaces. Proper moisture barriers and jacketing are important especially when used in flammable liquid services, wet climates, wash-down areas, and areas susceptible to leaking. It is not recommended for use over austenitic stainless steels or in areas where chlorides may invade the insulation system.

4. *MiFi: mineral fiber (fibrous insulation):*

Fibrous insulation is suitable for use in hot services up to 1200°F, and is usually the lowest cost system in this temperature range. It possesses low compressive strength and is therefore susceptible to damage; however, it is suitable for use in vibrating service.

MiFi is highly absorptive and can promote corrosion of carbon steel surfaces. Proper moisture barriers and jacketing are important, especially when used in flammable liquid services, wet climate, wash-down areas, and areas susceptible to leaking. It is not recommended for use over austenitic stainless steels or in areas where chlorides may invade the insulation system.

5. *UrFo: polyurethane/polyisocyanate foam (cellular insulation):*

Its low temperature range, excellent K factor, and competitive cost recommend polyurethane/polyisocyanate foam for use in cold service and chilled water applications. When used in cold service, it requires a vapor barrier.

It possesses low compressive strength and should not be used in areas of mechanical abuse, vibration, and mechanical or thermal shock.

It is a low absorptive material and does not promote corrosion under stainless steel or chloride cracking of austenitic stainless steels.

This material has some permeability, however, and often deteriorates with time. Humidity during application and water entry during service often degrade its performance and its conductivity. It is also vulnerable to a wide variety of chemicals, which could result in deterioration of the cellular structure, reaction with the substrate, or toxic contamination. For this reason, particular attention must be given to the specifications and application of the weather and vapor barriers.

Where space is a limitation, UrFo has advantages over other insulations due to the smaller thickness required.

6. *CeGl: cellular glass (cellular insulation):*

CeGl is suitable for hot (up to 900°F), cold, and dual-temperature services but it is usually the highest cost system in each of these services.

CeGl has good compressive strength but is very brittle. Therefore, it has a low tolerance for mechanical and thermal shock. In vibrating service, anti-abrasive coatings must be specified with this material.

CeGl has very low absorptivity; it does not promote chloride cracking of austenitic stainless steel or corrosion of carbon steel. It is therefore suitable for underground applications and is recommended for use over stainless steels. When used in cold service, a vapor barrier is not usually required (exceptions being severe or critical services). Care must still be taken, however, to vapor-seal the joints.

Because it is impervious to acids and other materials, CeGl is a suitable choice if absorption of toxic material is a concern.

7. *FIEI: flexible elastomer (closed cellular insulation):*

Flexible elastomer has a limited temperature range. Its good K factor, competitive cost, low absorptivity, and the availability of tubular shapes make it a specialized selection for freeze protection, of plumbing systems, and chilled water and refrigeration lines up to 5 in. in diameter.

It has low compressive strength and low absorptivity. Typical interior installations do not require a jacket covering. A weather-resistant protective coat is recommended by the manufacturer for outdoor installations.

8. *MeAm: melamine (open cellular insulation):*

Melamine is commonly known as Techlite or Thermazip, and has been used in the food industry and commercial applications on a trial basis because of price, ease of application, and clean coloring.

Test witnessing indicates that it shrinks in a short time and does not retain its insulating properties.

11.3.2.3 Comparison of Jacketing

This section presents a comparison of the uses, physical characteristics, limitations, etc., of the following types of protective jacketing systems:

FK	Aluminum foil bonded to kraft paper and reinforced with fiberglass fabric
FK-SSL	Same as above with pressure-sensitive sealing closure system (self-sealing tape)
TJ	Fiberglass coated fabric with Hypalon rubber fully secured and laminated to a Tedlar facing
TJ-VB	Above jacket with a vapor barrier of aluminized mylar laminated to the inner surface
MJ	Metal jacketing
MJ-AL	Metal jacket-aluminum
MJ-SS	Metal jacket-stainless steel
PVC	Fiberglass fabric coated with Hypalon rubber and laminated to the PVC
MAP	Mastic asphaltic
LTM	Low-temperature mastic (nonasphaltic)

1. FK and FK-SSL: aluminum foil bonded to kraft paper:

FK is suitable for jacketing on indoor preformed piping and rigid board insulation on pipe and equipment. It can be used outdoors only if another weatherproof jacket is applied over it.

FK is resistant to mild acid and alkali.

FK jacket service temperature limit is between -65 and 150°F . It should not be used in areas subject to mechanical or physical abuse. Its permeability rating at 0.02 is good.

2. TJ and TJ-VB: fiberglass fabric with Hypalon rubber and Tedlar facing:

TJ is suitable for jacketing on indoor and outdoor preformed piping and rigid board insulation on pipe and equipment. It is also unaffected by acids, bases, and most solvents, including hydrocarbons and chlorinated solvents.

TJ jacket service temperature is between -55 and 250°F . This fiberglass fabric is flexible and will not crack or split. It does not show dents or wrinkles. Its low permeability (0.02 perms) renders it suitable for use in wet environments. It is washable.

TJ resists ozone, oxygen, sunlight, and erosion.

3. *MJ-AL: metal jacket-aluminum:*

The aluminum jacket is suitable on rigid or semirigid insulation and on pipe or equipment at elevated temperatures indoors or outdoors. It has some resistance to mild chemicals only. One should check for specific applications. It is attacked by both acids and bases.

MJ-AL jacket service temperature limits exceed those of the insulation materials. Its good mechanical strength makes it suitable for large surfaces such as tanks, ducts, or equipment. For large diameters, its strength is further enhanced by being specified in corrugated form. It will withstand only moderate abuse; however, the specified thickness can be increased when used in areas of high mechanical or physical abuse.

MJ-AL is impermeable and is therefore suitable for use in wet areas when properly sealed at the seams. It is noncombustible but has a lower melting point than stainless steel.

MJ-AL should not be used in conjunction with stainless steel piping, in order to avoid galvanic corrosion. As it is very workable and readily available in a complete line of fitting covers and accessories, it is a popular selection. It is a much lower cost material than stainless steel.

4. *MJ-SS: metal jacket-stainless steel:*

MJ-SS is suitable for jacketing on rigid or semirigid insulation on pipe and equipment at elevated temperatures indoors or outdoors. It is also resistant to most organic solvents and corrosive chemicals, but not where chlorine is present.

MJ-SS jacket service temperature limits exceed that of the insulation material. Its high mechanical strength makes it suitable for large surfaces such as tanks, ducts, or equipment. It is this high mechanical strength that also makes it ideal for areas of severe abuse. For large diameters, its strength is further enhanced by being specified in corrugated form.

It is impermeable and is therefore suitable for use in wet areas when properly sealed at the seams. Because it is noncombustible, it can be used in areas of high fire risk, and is frequently used as a barrier on fire protection systems. It has a melting point higher than that of MJ-AL.

MJ-SS is ideal for use in conjunction with stainless steel piping in order to prevent galvanic corrosion.

5. *PVC: fiberglass fabric laminated to PVC:*

PVC (polyvinyl chloride) is suitable for jacketing on indoor preformed piping and rigid board insulation operating on pipe or equipment. However, due to ultraviolet rays, there is a maximum limitation of 20 in. outside diameter when exposed to direct sunlight.

PVC is unaffected by most acids and bases but it is affected by some hydrocarbons and chlorinated solvents. Chemical resistance charts should be checked for specific applications.

The PVC jacket service temperature limit is between -32 and 125°F .

It is a tough and flexible material that does not show dents. Because of its low permeability, PVC can be used in wet environments if the seams have been sealed properly. Because its flame spread is high, PVC is not recommended for use in areas of fire risk.

PVC is available from manufacturers in a full range of accessories. It is easy to apply in the field and can be cut for additional fitting covers. It is recommended that the vendor precurl the rolls to avoid extra cost in the field. Fiberglass fabric laminated to PVC is a relatively costly jacket alternative.

6. *MAP: mastic asphaltic coating:*

MAP is suitable for the vapor barrier coating of irregular-shaped equipment and pipe fittings in cold and dual-temperature services. It is resistant to dilute acids and alkali as well as abrasion. It must be stored and applied at temperatures of 40°F or higher. MAP material is combustible.

7. *LTM: low-temperature mastic (nonasphaltic):*

LTM is suitable for vapor barrier coating on irregular-shaped equipment and pipe fittings in cold and dual-temperature services, including cyclic temperature service. It is recommended for additional protection against chemical environments.

11.3.2.4 Design Requirements for Various Services and Systems

1. *Antisweat service:*

For antisweat as well as cold services of piping and equipment, it is necessary to keep the temperature of the insulation above the highest possible dew point temperature of the condensation temperature of the environment. As an aid, the outer cover should have a high emissivity.

For antisweat insulation thickness, vendors, tables can be used. The normal conditions used to select thicknesses to prevent condensation on the insulation outer surface are as follows:

Cover emissivity 0.9

Dry bulb 90°F

Relative humidity 80%

The thickness selected normally results in a heat gain of 9 to 10 Btu/h/ft² and these thicknesses are normally satisfactory for most applications. It is usually impractical to design for prevention of condensation for all conditions. Insulation vendors can usually provide an analysis of weather conditions for most parts of the United States, and they can provide an estimate of the percentage of the time that condensation can be expected at various insulation thicknesses for the operating conditions of the piping or equipment.

Antisweat insulation may also be used on nearby piping and equipment that is not part of a refrigeration system or does not contain fluids that are covered by a refrigeration system. Antisweat insulation is also used to control surface condensation at locations where the dripping of condensate may cause an electrical hazard to equipment or discomfort to personnel.

2. Cold service:

The design criteria for cold service insulation is to provide for the reduction in heat gain/loss or control excessive moisture condensation. Normal cold insulation is applied on piping and equipment that operates from ambient temperature to -100°F.

Insulation thickness for cold service is generally selected on the basis of a heat gain of 9 to 10 Btu/h/ft².

The service temperature of the insulation is affected by several factors: orientation, size, shape, and emissivity of the outside surface, and air movement. A shiny jacketed aluminum surface will require from two to three times the insulation thickness as will a dull black-coated surface to achieve the same surface temperature.

Choosing thicknesses from most vendors' charts for 90°F dry bulb and 90% relative humidity will result in heat gains of 4 to 5 Btu/h/ft². The increased thickness for zero heat gain is an additional 4 in. for a flat insulation or from 3.5 to 7.5 in. for pipe. The increase in cost is never justifiable. It must be emphasized that emissivity and wind have a substantial effect on heat gain and surface temperature, and these factors must be considered in any thickness calculation.

The control of moisture entering the insulation system is the single most critical aspect of cold insulation design. The insulating properties of wet insulation, water or ice, are much less than the insulation properties of dry insulation. The difference in the rate of heat transmission between dry insulation with a thermal conductivity of 0.35 Btu/h/ft² and ice with a thermal conductivity of 15.5 Btu/h/ft² is approximately 50 times. Although no insulation system reaches the conductivity of ice, this illustrates the need to keep cold insulation systems dry.

Metal jacketing is not normally used over insulation for cold service. However, in areas where severe abuse is expected, metal jacketing may

be specifically required over a vapor barrier mastic primary finish. The metal itself is not intended to be a vapor barrier. Proper precautions should be taken in those instances where metal jacketing is used so that metal edges do not promote a break in the mastic barrier.

To keep insulation systems dry, the following practices are given for cold service:

1. Insulation of attachments to cold equipment for some distance away from the cold surface is necessary to allow sufficient heat gain in the attachment to permit the metal to warm up to the dew point. A distance equal to the following factors times the insulating thickness has been used with reasonable success. This distance can be reduced by using specially designed thermal insulators or similar techniques.

–51°F to –100°F 2X or 2 times

150°F to –50°F 1X or 1 time

2. The requirement to insulate attachments includes cold equipment supports. The method used to support the equipment should be thought out carefully. Skirt-supported vertical equipment is usually not a problem because the skirts are generally long enough to allow sufficient insulation to be installed without covering the anchor bolts or base plates. Saddle-mounted equipment can be a problem. Saddles should be high enough so that the insulation can be terminated above the anchor bolts. Also, because the temperature of the base plates will be below the dew point, the expansion end should be equipped with noncorrosive expansion surfaces. Lug-mounted equipment should be avoided whenever possible because the need to insulate the supporting beams may make platform and wellway design complicated.
3. Leg-supported equipment should use pipe sections instead of structural shapes to simplify insulation sealing problems.
4. Where possible, equipment should be located in structures to minimize the need for structural attachments, such as ladders and platforms, to be attached directly to the equipment. Where such attachments are used, the metallurgy of the attachment inside the insulation must be reviewed to be certain it is suitable for the cold temperatures.
5. In addition to the above design practices aimed at keeping the insulation dry and consistent with reports of corrosion under insulation in NACE publication GH 189, carbon steel and austenitic stainless steel between –50 and 150°F should receive a protective coating prior to insulation.

The problem is most prevalent with plants in coastal areas and plants producing chloride-containing chemicals. A solution to the problem is to apply protective coatings to the metal or keep the insulation dry. Because the latter is difficult to assure, protective coatings appear to be the additional measure to avoid the problem.

Inorganic zinc coatings under insulation appear to accelerate rather than inhibit the corrosion of steel. They are to be avoided in the “wet temperature” range between 140 and 230°F. Inorganic zinc coatings are difficult to apply properly and are not the paint of choice.

The epoxy/urethane system currently used for bare steel will provide protection for insulated steel in the operating range between -50 and 200/250°F. An epoxy system is also a good choice for use under insulation where the urethane topcoat is replaced by a second epoxy coat. This system will continue to be a good standard system for chloralkali plants and for Gulf Coast plants for insulated and bare carbon steel.

The amine-cured coal tar and modified epoxy system is recommended for cold (-50°F to 50°F) and cyclic services where frequent heating and cooling will be an operating mode. In these cases, it is worth the inconvenience of having a two-paint system on the project.

6. As a wet environment under insulation can lead to an accumulation of chlorides and chloride stress cracking with austenitic stainless steels, stainless steel that is insulated with a cold service cellular glass system (permeability 0 to 0.005 perm/in.) and that will keep moisture out does not require a protective coating. Use of other insulating materials and hot service insulating systems requires that the stainless steel receive a protective coating prior to insulation. Use either an epoxy phenolic or coal tar epoxy. Proper preparation is essential when painting stainless steel.

3. *Cryogenic service:*

This type of insulation is applied on piping and equipment operating below the temperature range for normal cold insulation (-100°F to -450°F), and a study should be done to determine if special insulation systems, for example, cold box-type or double-wall, are economically justified. The vapor barriers and design considerations require special studies with the suppliers of cryogenic insulation.

4. *Hot service:*

Normally, the thickness of the insulation must result in a heat loss of $4 \pm 1\%$ of the heat loss for bare pipe or equipment. For hot systems, the surface temperature should be less than 140°F for nonmetallic covers and less than 130°F for metallic covers over insulation.

Refer to Table 11.1 and the characteristics of the different insulations. Absorptive insulations (e.g., fiberglass, mineral wool, calcium silicate) will initiate corrosion on the underlying surfaces. Alternatively, wet and dry cycles within the insulation will induce corrosion of carbon steel and chloride stress corrosion cracking of austenitic stainless steels. To ensure against corrosion under insulation, nonabsorptive insulation materials should be considered. Coating systems applied before insulation are protective to metal surfaces when conditions are severe. The comments under cold service for protective coating apply in the intermediate temperature range between 140 and 230°F.

For elevated temperature service, the vapor barrier system must be sufficiently permeable to vent moisture vapors yet resist the passage of liquid water inward.

See Section 11.3.2.3 on jacketing and Table 11.2 for the outer covers.

5. *Special environments:*

Corrosive chemicals, including caustic soda (NaOH) vapor, dust, or liquid spillage, will chemically attack galvanized surfaces. For this reason, stainless steel (rather than galvanized) tie wires have been specified in all installation systems.

6. *Piping systems:*

Because piping systems need to be enclosed completely by the insulation system in order to keep out any moisture, the piping designer must envision the insulated system. All supports should be outside the insulation to minimize the sealing problem. Insulated pipe supports are available that use cellular glass as the insulating material. In some cases, inserts of higher compressive strength materials must be used, such as calcium silicate. This is acceptable when necessary if precautions are taken to preclude the entrance of water into the insert material.

Valves should be specified with extended bonnets so that the sealing surface is above freezing at average winter temperatures. When possible, anchors and guides need special attention and may require additional pipeway spacing, depending on the design. Vents, drains, and other connections should be minimized, particularly in very cold services. Piping manifolds should be laid out so

that the insulation can be properly sealed without hindering valve operation.

7. Tank design:

The design of roof insulations presents special problems due to wind and the flexing of the roof. The insulation must be secured to the roof either by pinning, cabling, or adhesion.

It is very difficult to design and maintain a dry roof insulation system. The sealants around the nozzles and other projections have finite lives, and the possibility of puncture due to foot traffic or leaks caused by roof flexing is very high. Insulation that does not absorb water is preferred, and there should be a definite separation between the wall and roof insulation. An angle with an outstanding leg is required to provide the separation.

The radial loads that can be withstood by $\frac{3}{4}$ -in. banding are small for large-diameter equipment. To have an adequate system, the use of this size band requires that the bands be anchored at frequent intervals. It may be cost effective to use welded pins to impale the insulation. Where pins are not permitted by code, a proprietary system using wider bands or rib-type attachments should be considered. More recently developed prefabricated insulation systems should be investigated. However, system selection may be necessary prior to the final design of the tank or vessel so that adequate supports can be provided.

The bottom 12 in. of tank wall insulation should be nonwicking to prevent moisture being drawn up into the insulation. Locations with high probability of high water in the tank dike may require up to 48 in. of nonwicking insulation. Cellular glass is the preferred material for this bottom section of insulation on the tank.

For further details and design plates, refer to the *Commercial and Industrial Insulation Standards* published by Midwest Insulation Contractors Association (MICA) at 2202 Hanscom Blvd., Omaha, NE 68105.

11.3.3 Industries and Systems Covered

In this section the materials and methods generally used in the following representative industries and systems are discussed: chemical, petroleum refinery, water treatment and supply systems, gas industry, pipeline industry, marine industry, telephone industry, nuclear power industry, and aerospace industry.

The basic design techniques used by the various industries will fall into one of the following categories:

1. Materials selection
2. Environment and inhibitors
3. Coatings and linings
4. Cathodic protection or sacrificial materials
5. Special procedures such as plant and physical layout or the control of process variables

11.3.3.1 Chemical Industry

Those responsible for the selection of materials of construction are normally materials or corrosion engineers. Materials other than metal are widely used in the chemical industry, so the engineer must know the technical and scientific information with regard to the deterioration of plastics, graphite, wood, rubber, concrete, elastomeric materials, roofing materials, coatings, linings, glass, brick, and mortars, among the many materials used in the chemical industry.

In addition to the production and manufacture of chemicals, the industry also includes pharmaceuticals, fertilizers, mining, and metal extraction. The similarities among these different sectors of the industry lie in the handling of liquids, solids, and gases. There is also the handling of acids, bases, and salts, both inorganic and organic. There is a need in most cases to maintain the purity of the product, or the avoidance of corrosion in the product. Economy demands a maximum lifetime of processing equipment at minimum cost, with minimum labor requirements in both the operation and the maintenance of the plant.

The methods of corrosion control include:

1. Materials selection
2. Environmental changes, inhibitors
3. Coverings or liners
4. Design improvements
5. Specifications for purchasing and/or contractors
6. Regular inspection and improved techniques

Materials selection. By upgrading to the proper materials of construction, one can often avoid or at least minimize the effect of a given environment. Many tables are available giving the resistance of various materials of construction in various environments. This includes miscellaneous materials such as glass. Not that glass is the ultimate material of construction, but it does have a wide range of chemical resistance to all strongly acidic conditions including hydrochloric acid. Glass has been developed that is armorized to overcome its brittleness.

Environmental changes; inhibitors. In addition to changing the environment by the use of inhibitors, changes can reduce corrosion by altering the temperature and/or pressure in the process.

The economics of inhibitors can be favorable for a closed loop such as a cooling circuit for a chemical process. In a closed loop, the concentration may be 0.1% by weight or less of the inhibitor compared to the concentration of the major corrodent. Even at this low concentration in a once-through circuit, inhibitors are generally too expensive to use. Inhibitors such as nitrites, phosphates, and silicates are used singly and sometimes in combination. It should be noted that an inhibitor for one material is often an accelerator of corrosion for another material. An example is amine, which can be relatively effective on steel and can cause stress corrosion cracking of copper-based materials because of the ammonia complex.

Many companies specialize in the development and manufacture of inhibitors for particular metals in specific environments. These materials lend themselves to certain production operations.

There is a class of inhibitors that works in the vapor phase, rather than in the liquid phase, in preventing oxides and rust on common metals. These vapor-phase inhibitors are generally organic in nature and have a relatively high volatility compared to the crystalline solid material. Crystals of a vapor-phase inhibitor can be placed in an open container in a closed vessel, and it will be found that the interior surface of this vessel will not rust or oxidize even if water vapor or oxygen enters the vessel. Vapor-phase inhibitors have been used to maintain standby equipment such as boilers, turbines, and spare tanks. This type of inhibitor can be applied by fogging a solution containing the crystals into the container, where the solid inhibitor crystallizes and puts a monomolecular film on the surface of the container.

Coverings or liners. Protective coatings may prove to be an inexpensive substrate compared to the material selection or the use of an inhibitor. The coating acts as a nonactive barrier between the environment and the substrate. The coating must be impervious or almost impervious to the environment. It must be continuous (free of voids or pinholes) and should be sufficiently durable to withstand the temperature and pressure conditions. There are many committees of NACE, such as the Technical Practices Committee (T-6), that have been involved in the special requirements for coatings for atmospheric exposure and linings for immersion coatings. There are various ramifications to the application of liquid-applied linings, sheet linings, and brick membrane linings. When these linings or combinations of linings are found to be resistant to the environment, checks must be made of the difference in the expansion coefficient of the lining and the substrate, especially if there is a temperature gradient or a large change in temperature between the lining and the substrate. A material with superb corrosion resistance is not the answer if it cracks because its expansion is greater than that of the vessel in which it is installed.

Design improvements. Design improvements can entail changes to the process conditions. Studies of the mechanism of corrosion can result in the use of more expensive material in the areas of the corrosion rather than the complete vessel. In dead, or no-flow conditions, the use of a neutral or inert nitrogen gas purge may save a relief valve or other items from corroding. The selection of the feedstock without certain corrosive impurities may prove to be the most economical answer.

Specifications for purchasing and/or contractors. Better specifications will result by the use of the findings of various associations such as NACE, as was discussed previously under linings and the surface preparation conditions. Materials selection also entails materials with properties within specified guidelines.

Regular inspection and improved techniques. Concerning inspection, zinc-rich primers under coatings offer long, maintenance-free life providing there is continuous inspection and patch repair. The zinc-rich primers are either organic or inorganic. The application depends on the specifications for the surface preparation and various restrictions during the application. The use of zinc-rich primers with various topcoats usually requires cathodic protection for localized breaks in the primer over the metal. The aggressiveness of the environment for a particular zinc primer must be balanced with the frequency of repair. In an aggressive atmosphere, even the most protective coating system installed with the finest specifications requires continuous inspection. The better the system, the less frequent and smaller the amount of repairs. A protective coating system in a strong chemical environment should not be expected to last indefinitely.

11.3.3.2 Petroleum Refining Industry

The petroleum refining industry uses sweet or sour crude (contains H_2S) in the various operating units to be described in greater detail in this section. These units in a refinery will be handling saturated and unsaturated hydrocarbons under both high and low temperature and pressure conditions. In the processing of the crude oil, the refinery will use either a sea, brackish, or ordinary water system; various purities and pressures of steam and condensate return; hydrogen, acid, and furfural to sweeten lubrication oil and other petroleum products; ammonia, and caustic.

Design prevention or reduction methods against corrosion for refineries include:

1. Materials selection
2. Crude selection and corrosivity
3. Use of pretreatment of the crude oil
4. Use of corrosion inhibitors

5. Adjustments in process conditions
6. Removal of sulfur and other impurities

Materials selection. The corrosion table for specific metals and alloys can be used to guide the selection of various corrodents for the conditions that will occur in the refinery.

For sections of the refinery subjected to high-pressure hydrogen at elevated temperatures, such as the hydrocracking, the empirical Nelson curves and the appropriate ASME codes are used. The Nelson curve is used and recommended by the American Petroleum Institute (API), and it is updated from time to time. To check the latest edition, contact the API (1220 L Street NW, Washington, DC 20005-4070).

The applicable ASME Boiler and Pressure Vessel Code is Section VIII, Divisions 1 and 2, and provides the design limits for steels in high temperature and pressure service.

Because of its insidious nature, hydrogen attack is difficult to detect in on-stream equipment. The initial stages can only be detected by metallographic examination of samples cut off the equipment, whereas severe damage can be detected on-stream by ultrasonic measurements.

Low-temperature hydrogen is equally insidious but can usually be controlled by modifications in process conditions. Washing the process streams with water to remove some of the corrodents or adding corrosion inhibitors can sometimes alleviate the problem. Recommended practices have been developed by the API and NACE to minimize the susceptibility of welds to cracking from low-temperature hydrogen attack. Experience indicates that a weld hardness of less than Brinell 200 is satisfactory for refinery equipment in severe environments. Welds greater than 200 Brinell should be given a tempering heat treatment.

Refinery equipment that handles strong acids and bases requires special corrosion protection, as in the chemical industry. Similarly, the cooling and boiler water treatments are basically the same as those practiced in the utilities industry, as discussed in the section on water treatment and supply systems. Corrosive vapor and acid condensates containing carbon dioxide, sulfur dioxide, and hydrogen sulfide are encountered in other processing units, such as distillation towers. Methods of treatment are by inhibitors and materials selection, using economics in finalizing the decision-making process.

Sulfur compounds are especially troublesome, causing corrosion and poisoning catalysts. Hydrogen sulfide may be a dissolved component of the crude oil or formed in the distillation furnaces, hydrosulfurization units, or hydrocrackers. Both the organic sulfur and hydrogen sulfide are corrosive to carbon steel above 500°F (ASTM STP-558). For sulfur removal, the products or the crudes are treated catalytically with high-pressure, high-temperature hydrogen. The mixture of H₂S and H₂ requires special precautions

in alloy selection in the naphtha and gas oil desulfurization unit and the hydrocracking unit of a refinery.

At high temperatures, high-pressure hydrogen diffuses into metals and reacts with the carbon steel to form methane. The reaction causes fissuring and blistering, as well as decarburization of the steel, with a consequent loss in ductility. Then catastrophic failure can occur without warning and with no visible deterioration of the metal.

Hydrogen is also produced by aqueous acid corrosion at low temperatures. In this case, hydrogen atoms, or ions, form at the metal surface, rapidly diffuse inward, and then form hydrogen molecules at defects or dislocations within the metal. Because these molecules cannot diffuse out of the metal at low temperatures, pressures of several pounds (psi) can build up and cause cracks, blisters, and serious ruptures. Such damage is particularly severe in the fractionation section of fluid catalytic cracking units or vapor recovery units where there are cyanides and hydrogen sulfide, both of which accelerate the diffusion of hydrogen into steel. Welds, which are often significantly stronger than the base metal, are especially susceptible to cracking from this hydrogen.

The strong acids and bases required in many refining processes can be particularly corrosive. These include the sulfuric and hydrochloric acids used as alkylation catalysts and the aluminum chloride plus hydrochloric acid used as both an alkylation and isomerization catalyst. Caustic soda is used to remove entrained acids from products, and the several bases such as monoethanolamine and potassium carbonate used to remove hydrogen sulfide and carbon dioxide from fuel gases. Although the bases alone are not corrosive, the dissolution and release of acid gases can cause severe corrosion, hydrogen blistering, and stress corrosion cracking. The amount of acid gases dissolving in the water that condenses on the storage tank roofs or separates to the bottom of the tanks usually determines the life of such vessels and the amount of maintenance required (ASTM 1973 Symposia STP-558).

Naphthenic acids are initially present in most crudes at very low concentrations but can lead to corrosion in stainless steel sections of the vacuum distillation tower where type 410SS is used. The identification of naphthenic acid corrosion may be confused with high-temperature sulfide corrosion because of the similarity of the sharp-edge pits and grooves. In the fractionation process, sufficiently high local concentrations of the naphthenic acids can occur at temperatures between 450°F and 650°F to corrode stainless steels that normally resist sulfide corrosion. The metal naphthanates are soluble in oil, so the scale on the corroded metal is iron sulfide, which further complicates diagnosis. What constitutes a dangerous concentration of naphthenic acids is not clear but authorities suggest that corrosion will occur if the neutralization number is above 0.5 mg KOH/g of crude.

Perhaps the most pervasive sources of corrosion are the large amounts of water and steam required in refineries. Cooling water, both once-through and circulating from cooling towers (generally several times the volume of the crude being processed), is responsible for both corrosion and scaling of

pipings and exchangers. Coastal refineries face the added problem of seawater corrosion in the coolers.

Steam is used to heat-process hydrocarbon streams in the refinery in order to remove gases from the hydrocarbons, but often high-pressure steam is also produced to operate turbine generators for electricity. The discharged low-pressure steam goes to the process units for heat or stripping purposes. Thus, very little steam condensate is returned to the boilers, and chemical treatment of the boiler feed water is more critical than in many utilities. In addition, refineries burn waste by-products that are too dirty or corrosive to sell. Thus, furnaces and the gas venting systems require more alloying or chemical treatment than typical steam-generating plants.

Crude selection and corrosivity. If a refinery has the opportunity of choosing or changing its crude oil supply, a crude oil corrosivity test is valuable to ensure that the refinery will not suffer excessive corrosion or incur major cost increases in handling a particular crude. Crude oils are analyzed primarily for salt and sulfur (sourness) contents to estimate corrosivity. Tests have been derived to correlate corrosion with HCl and H₂S evolution when the crude is heated at a controlled rate. Various correlations have been made, including:

- Crude fractionator overhead corrosion with HCl evolution
- Crude unit corrosion with H₂S evolution
- Heating equipment corrosion with the cumulative H₂S release

Use of pretreatment of the crude oil. The first step in the processing of crude oil will be desalting and dewatering by one of the methods listed below.

Separation Method	Temp. (°F/°C)	Type of Treatment
Chemical	140–210/60–99	0.05–4% solution of soap in water 0.5–5% solution of soda ash in water
Electrical	150–200/60–93	10,000–20,000 V
Gravity	180–200/82–93	Up to 40% water added
Centrifugal	180–200/82–93	Up to 20% water added (sometimes no water added)

The crude that enters the refinery may be as high as 4 to 5% in water, and the water content may be higher than the equilibrium because water is present as an emulsion.

Because of the high temperature of the heated tubes, the introduction of the wet crude into the heaters would be dangerous. In addition, the salt would precipitate onto the walls, reducing the rate of heat transmission and thereby the efficiency of the heaters. Stated simply, the crude oil is heated, an emulsion breaker is added, and the resultant mass is settled (or even filtered) to remove the salt and water phase from the oil phase.

Use of corrosion inhibitors. Caustic added to crude oils before and after desalting helps suppress chloride hydrolysis and reduces corrosivity by making the hot, salt-laden desalter water alkaline. Caustic may also remove some of the naphthenic acids.

Ammonium hydroxide, ammonia, monoethanolamine, diethanolamine, and morpholine are added to the overhead vapors from distillation towers to ensure that the condensed water has a pH of 5 or greater. This inhibitor can completely stop corrosion and provide conditions under which corrosion inhibitors can stop corrosion, providing the salts of the neutralization reaction do not deposit in the overhead condensers. The amount of neutralizer must be carefully controlled to avoid caustic stress cracking of steel and ammonia or amine stress corrosion cracking of copper alloys.

Refinery corrosion inhibitors are mostly solid, high molecular weight nitrogen compounds (amides, amines, imidazolines, and their salts with fatty acids) dissolved in hydrocarbon solvents. They are also generally surfactants and function by forming protective films on metal surfaces.

Adjustments in process conditions. Corrosion control often can be attained by simple changes in operating conditions with little or no economic penalty. For example, the acid gases (HCl, H₂S, CO₂, and SO₂) are not corrosive at moderate temperatures, provided there is no aqueous condensation; consequently, raising the gas temperature, lowering the pressure, and installing insulation or steam-tracing equipment often can eliminate the danger that the gases will cause severe corrosion or stress corrosion cracking. In areas of equipment with little or no process flow such as relief valves, bypass lines, and instrument lines, the accumulation of corrosive gases can be prevented by a small flow (bleed) of hot process gas or a dry purge gas.

Process corrosion can be minimized if it is possible to reduce the process temperature. This approach, however, is not usually practical. High-temperature sulfidic corrosion in hot process streams can be monitored with corrosion probes. Even if there is no practical remedy, at least the probes measure corrosion without having to shut down the unit. The equipment life can be estimated and a resistant alloy selected and fabricated to replace the corroded equipment quickly and economically at a shutdown scheduled before the equipment becomes defective.

Removal of sulfur and other impurities. This is a specialized kind of hydrogenation in which the quality of the liquid hydrocarbon stream is improved by subjecting it to mild or severe conditions of hydrogen pressure in the presence of a catalyst. The objective is to convert undesirable or corrosive material in the feedstock to either desired material or easily disposed of by-products on a selective basis. As of the early 1980s, about 45% of the crude oil refined in the United States was hydrotreated. Some applications of hydrotreating accomplish the following:

- Reduction of sulfur content of residual fuel oil
- Pretreatment of catalytic cracking feeds and crude oils by removal of metals, sulfur, and nitrogen
- Desulfurization of distillate fuels

11.3.3.3 Water Treatment and Supply Systems

There are several ways to reduce or inhibit corrosion that are within the capabilities of most water utilities. This section describes several methods most commonly used to control corrosion. However, the utility operator must select the best and most economical. These methods include:

1. Modify the water quality
 - a. pH adjustment
 - b. Reduce/remove oxygen
2. Linings, coatings, and paints
3. Proper selection of system materials and adequate system design
4. Use of inhibitors
5. Cathodic protection

Modify the water quality. In many cases, especially in existing plants, the easiest and most practical way to make water less corrosive is to modify the water quality at the treatment plant. Because of the differences among raw water sources, the effectiveness of any water quality modification technique will vary from one water source to another. However, where applicable, water quality changes can often result in an economical method of corrosion control. Common methods of modifying water quality include pH adjustment, pH control, and reducing oxygen.

pH adjustment is the most common method of reducing corrosion in water distribution systems. Control of the pH plays a critical role in corrosion control of water systems for the following reasons:

- Acid waters are generally corrosive. Waters with pH below 6.5 generally cause uniform corrosion of the materials. In the pH range between 6.5 and 8, the attack is more likely to be pitting.
- pH is the major factor that determines the solubility of most pipe materials. Most materials used in water distribution systems (copper, zinc, lead, cement) dissolve readily at a lower pH.
- The relationship between pH and other water quality parameters, such as alkalinity, carbon dioxide, and total dissolved solids (TDS), governs the solubility of calcium carbonate, which is commonly used to provide a protective scale on interior pipe surfaces. To

deposit this protective scale, the pH of the water must be slightly above the pH of saturation for CaCO_3 , provided sufficient alkalinity and calcium are present.

For systems that do not rely on CaCO_3 deposition for corrosion control, it is more difficult to estimate the optimum pH. If lead and/or copper corrosion is a problem, adjusting the pH values from 7.5 to 8.0 or higher may be required. Practical minimum lead solubility occurs at a pH of about 8.5 in the presence of 30 to 40 mg/L of alkalinity. Adjustment of pH coupled with carbonate supplementing may be required to minimize lead corrosion problems.

Phosphates and other corrosion inhibitors often require a narrow pH range for maximum effectiveness. If such an inhibitor is used, consideration must be given to adjusting the pH range to within the recommended value.

It is recommended that the effects of pH change over time be monitored. Evaluating the performance of chemical feed systems for pH adjustment is the key to an effective corrosion control program. Addition of lime, soda ash, or other chemicals for pH control can be evaluated by a continuous-readout method for successful corrosion control in this system. Because of the specific water quality and pipe materials in a system, a particular method may be successful in one system but not in another.

There are three basic approaches to corrosion control of pipe material in direct contact with the water:

1. Modify the water quality so that it is less corrosive to the piping by pH adjustment or oxygen removal.
2. Place a protective barrier or lining between the water and the pipe.
3. Select a pipe material and design the system so that it is not corroded or is less corrosive to a given water.

Other common ways of achieving corrosion control include the use of inhibitors and cathodic protection.

Recorders can be used to monitor the pH of the water as it leaves the utility and can be wired to send a signal to the feed mechanisms to add more or fewer chemicals as necessary. The pH levels at the outer reaches of the distribution system should be checked periodically for any indications of changes occurring within the system that might be due to corrosion.

Keep in mind that although pH adjustment can aid in reducing corrosion it cannot eliminate corrosion in every case. However, pH adjustment is the least costly and most easily implemented method for achieving some corrosion control, and utilities should use it if at all possible.

Oxygen removal is another method used to inhibit corrosion. Oxygen is an important corrosive agent for the following reasons:

1. It can act as an electron acceptor, allowing corrosion to continue.
2. It reacts with hydrogen to depolarize the cathode and thus speed up corrosive reaction rates.
3. It reacts with iron ions to form tubercles and leads to pitting of copper.

If oxygen could be removed from water economically, the chances of corrosion starting, as well as the corrosion rate once started, would be reduced. Unfortunately, oxygen removal is too expensive for municipal water systems and is not a practical method of control. However, there are ways to minimize the addition of oxygen to the raw water, particularly groundwaters.

Often, aeration is the first step in treating groundwaters having high iron, hydrogen sulfide (H_2S), or CO_2 content. Although aeration helps remove these substances from raw water, it can also cause more serious corrosion problems by saturating the water with oxygen. In lime-soda softening plants for the treatment of groundwater, the water is often aerated first to save on the cost of lime by eliminating free CO_2 . Iron is oxidized and precipitated in this step, but this is incidental because the iron would be removed in the subsequent softening process even if the water were not aerated. The actual result is that the dissolved oxygen (DO) increases to near-saturation, and corrosion problems are increased. Thus, the attempt to save on lime addition may actually end up costing a great deal in corrosion damage.

Measures that help keep the DO as low as possible include:

- Sizing well pumps and distribution pumps so as to avoid air entrainment
- Using as little aeration as possible when aerating for H_2S and CO_2 removal

This can be achieved by bypassing the aerators with part of the raw water. It has even been possible to eliminate completely the use of aerators if enough detention time is available in the reservoir so that enough oxygen can be absorbed at the surface to oxidize the H_2S or to let the CO_2 escape. DO levels can be kept as low as 0.5 to 2.0 mg/L by this method. This is low enough in many cases to reduce corrosion rates considerably.

Linings, coatings, and paints. Another way to keep corrosive water away from the pipe wall is to line the wall with a protective coating. These linings are usually mechanically applied, either when the pipe is manufactured or in the field before it is installed. Some linings can even be applied after the pipe is in service, although this method is much more expensive. The most common pipe linings are coal-tar enamels, epoxy paint, cement mortar, and polyethylene.

Water storage tanks are most commonly lined to protect the inner tank walls from corrosion. Common water tank linings include coal-tar enamels and paints, vinyl, and epoxy.

Although coal-tar-based products have been widely used in the past for contact with drinking water, currently there is concern at the EPA about their use because of the presence of polynuclear aromatic hydrocarbons and other hazardous compounds in coal tar and the potential for their migration in water. Table 11.3 summarizes the most commonly used pipe linings and lists their advantages and disadvantages. Common water tank linings are summarized in Table 11.4.

Proper selection of system materials and adequate system design. In many cases, corrosion can be reduced by properly selecting system materials and having good engineering design. Some pipe materials are more corrosion resistant than others in a specific environment. In general, the less reactive the material is with its environment, the more resistant it is to corrosion. When selecting materials to replace old lines or putting new ones in service, the utility should select a material that will not corrode in the water it contacts. Admittedly, this provides a limited solution because few utilities can select materials based on corrosion resistance alone. Usually, some alternative material must be compared and evaluated based on cost, availability, ease of installation, and maintenance, as well as resistance to corrosion. In addition, the utility owner may not have control over the selection and installation of the materials for household plumbing. There are, however, several guidelines that can be used in selecting materials.

First, some materials are known to be more corrosion resistant than others in a given environment. For example, a low-pH water that contains high DO levels will cause more corrosion damage in a copper pipe than in a concrete or cement-lined pipe. Other guidelines relating water quality to materials selection are given in Table 11.5.

A good description of the proper selection of materials can be found in *The Prevention and Control of Water Caused Problems in Building Water Systems*, published by NACE.

Second, compatible materials should be used throughout the system. Two metal pipes having different activities, such as copper and galvanized iron, that come in direct contact with others can set up a galvanic cell and cause corrosion. The causes and mechanisms of galvanic corrosion are discussed in other sections of this book. As much as possible, systems should be designed to use the same metal throughout, or to use metals having similar positions in the galvanic series. Galvanic corrosion can be avoided by placing dielectric (insulating) couplings between dissimilar metals.

Use of inhibitors. There are several different types of phosphates used for corrosion control, including polyphosphates, glassy polyphosphates, and bimetallic polyphosphates. Recent developments in corrosion control include the use of zinc with a polyphosphate or orthophosphate.

TABLE 11.3

Pipe Wall Linings

Material	Use	Advantage	Disadvantage
Hot applied coal-tar enamel	Lining for steel pipes (used in 50–80% of steel pipes in distribution systems)	Long service life (+50 yr) Good erosion resistance to silt or sand Resistant to biological attachment	Need to reapply to welded area Extreme heat may cause cracking Extreme cold may cause brittleness May cause trace organics in water
Epoxy	Lining for steel and ductile iron pipes Can be applied in field or foundry	Smooth surface results in reduced pumping costs Formulated from components approved by Food and Drug Administration	Relatively expensive Less resistant to abrasion than coal-tar enamel Service life approx. 15 yr
Cement mortar	Standard lining for ductile iron pipes, sometimes used in steel or cast iron pipes	Relatively inexpensive Easy to apply, can be applied in place or in pipe-manufacturing process Calcium hydroxide release may protect uncoated metal joints	Rigidity of lining may lead to cracking or sloughing Thickness of coating reduces cross-sectional area of pipe and reduces carrying capacity
Polyethylene	Lining used in ductile iron and steel pipe (applied at foundry)	Long service life (50 yr) Good erosion resistance to abrasives (silt and sand) Good resistance to bacterial corrosion Smooth surface results in reduced pumping costs	Relatively expensive

Low dosages (about 2 to 4 mg/L) of glassy phosphates, such as sodium hexametaphosphate, have long been used to solve red-water problems. In such cases, the addition of glassy phosphates makes the color, and the water appears clear because the iron is tied up as a complex ion. The corrosive symptoms are removed but the corrosion rates are not reduced. Controlling actual metal loss requires dosages up to 10 times higher (20 to 40 mg/L)

TABLE 11.4

Water Storage Tank Linings and Coatings

Material	Comments
Hot applied coal-tar enamel	Most common coal tar-based coating used in water tanks tends to sag or ripple when applied above the water line when tank walls are heated
Coal-tar paints	Most commonly used to reline existing water tanks Those paints containing xylene and naphtha solvents give the water an unpleasant taste and odor, and should be used only above the water line Other coal-tar paints containing no solvent base can be used below the water line but should not be exposed to sunlight or ice Service life 5–10 yr
Coal-tar epoxy paints	Less resistant to abrasion than coal-tar enamel Can cause taste and odor problems in the water Service life about 20 yr
Coal-tar emulsion paint	Good adhesive characteristics, odorless, and resists sunlight degradation but not as watertight as other coal tar paints, which limits use below water line
Vinyl	Nonreactive, hard smooth surface Service life approx. 20 yr Is reduced by soft water conditions
Hot and cold wax coatings	Applied directly over rust or old paint Short service life approx. 5 yr
Metallic-sprayed zinc coating	Relatively expensive process that requires special skills and equipment Good rust inhibition Service life up to 50 yr
Zinc-rich paints	Hard surface Resistant to rust and abrasion Relatively expensive
Chlorinated rubber paints	Used when controlling fumes from application of other linings is difficult or when their use is specified
Asphalt-based linings	Use generally limited to relining existing asphalt-lined tanks

of the glassy phosphates. Other glassy phosphates that contain calcium as well as sodium are more effective as corrosion inhibitors. Using zinc with a phosphate has been successful in both inhibiting corrosion and controlling red water at dosages of 2 mg/L. The zinc phosphate treatment has been used to eliminate rusty water, blue-green staining, and lead pickup, and to reduce the measured corrosion rate of metals.

The choice of a particular type of phosphate to use in a corrosion control program depends on the specific water quality. Some phosphates work better than others in a given environment. It is usually advisable to conduct laboratory or field tests of one or more phosphate inhibitors before long-term use is initiated. The case histories in Section 8 of the Noyes publication *Corrosion*

TABLE 11.5

Corrosion Properties of Frequently Used Materials in Water Distribution Systems

Distribution Material	Corrosion Resistance	Associated Potential Contaminants
Copper	Good overall corrosion resistance Subject to corrosive attack from high velocities, soft water, chlorine, dissolved oxygen, and low pH	Copper and possibly iron, zinc, tin, arsenic, cadmium, and lead from associated pipes and solder
Lead	Corrodes in soft water with low pH	Lead (can be well above MCL ^a), arsenic, and cadmium
Mild steel	Subject to uniform corrosion Affected primarily by high dissolved oxygen levels.	Iron, resulting in turbidity and red-water complaints
Cast or ductile iron	Can be subject to surface erosion by aggressive waters	Iron resulting in turbidity and red water complaints
Galvanized iron	Subject to galvanic corrosion of zinc by aggressive waters Corrosion is accelerated by contact with copper materials and at higher temperatures as in hot water systems	Zinc and iron; cadmium and lead (impurities in galvanizing process may exceed primary MCL ^a)
Asbestos-cement	Good corrosion resistance Immune to electrolysis Aggressive waters can leach calcium from cement	Asbestos fibers
Plastic	Resistant to corrosion	

^a MCL = Maximum contaminant levels.

Prevention and Cold Water Treatment and Supply Systems provide several examples of how such tests are performed and evaluated.

For smaller water utility plants (up to 1 million gallons per day [MGD]), phosphate feed solutions can be made up easily by batch as needed. A maximum phosphate solution concentration of 10 wt% or 0.834 lb/gal is normally recommended. For a phosphate dose of 3 mg/L and a flow of a or 1 MGD, the volume of phosphate solution fed can be calculated as follows:

$$1 \text{ MGD} \times 3 \text{ mg/L} \times \frac{8.34 \text{ lb/Mgal}}{\text{mg/L}} \times \frac{1 \text{ gal}}{0.834 \text{ lb}} = \frac{30 \text{ gal}}{\text{day}}$$

The equipment needed to feed phosphates to the water includes a 55-gal-lon solution feed tank, a drum mixer, a chemical feed metering pump, and assorted piping, feed lines, valves, and drains. The capital expenditure required is usually relatively small and is therefore within the means of most small water utilities.

Sodium silicate (water glass) has been used for over 50 years to reduce corrosivity. The way in which sodium silicate acts to form a protective film is still not completely understood. However, it can effectively reduce corrosion and red water in galvanized iron, yellow brass, and copper plumbing systems in both hot- and cold-water systems.

The effectiveness of sodium silicate as a corrosion inhibitor depends on water qualities such as pH and bicarbonate concentration. As a general rule, feed rates of 2 to 8 mg/L and possibly up to 12 mg/L sodium silicate are sufficient to control corrosion in a system once a protective film is formed. Silicate has been found to be particularly useful in waters having very low hardness and alkalinity, and a pH of less than 8.4. It is also more effective under higher velocity conditions. The equipment needed to feed sodium silicate is the same as needed to add phosphate.

Cathodic protection. Cathodic protection is an electrical method for preventing the corrosion of metallic structures. Metallic corrosion involves contact between a metal and an electrically conductive solution that produces a flow of electrons or current from the metal to the solution. Cathodic protection stops the current by overpowering it with a strong current from some outside source. This forces the metal that is being protected to become a cathode; that is, it has a large excess of electrons and cannot release any of its own.

There are two basic methods of applying cathodic protection. One method uses inert electrodes, such as a high-silicon cast iron or graphite, that are powered by an external source of direct current. The current impressed on the inert electrodes forces them to act as anodes, thus minimizing the possibility that the metal surface being protected will become an anode and corrode. The second method uses a sacrificial galvanic anode. Magnesium or zinc anodes produce a galvanic action with the iron such that they are sacrificed (or corrode), while the iron structure to which they are connected is protected from corrosion. This type of system is common in small water heaters. Another form of sacrificial anode is galvanizing, where zinc is used to coat iron or steel. The zinc becomes the anode and corrodes, protecting the steel, which is forced to be the cathode.

The primary reason for applying cathodic protection in water utilities is to prevent internal corrosion in water storage tanks. Because of the high cost, cathodic protection is not a practical corrosion control method for use throughout a distribution system. Another limitation of cathodic protection is that it is almost impossible for it to reach holes, crevices, or internal corners.

11.3.3.4 Design Features

The design of the pipes and structures is as important for water supply systems as the choice of construction materials. A faulty design may cause severe corrosion, even in materials that may be highly corrosion resistant. Some important design considerations include:

1. Avoiding dead ends and stagnant areas
2. Using welds instead of rivets
3. Providing adequate drainage where needed
4. Selecting an appropriate flow velocity
5. Selecting an appropriate metal thickness
6. Eliminating shielded areas
7. Reducing mechanical stresses
8. Avoiding uneven heat distribution
9. Avoiding sharp turns and elbows
10. Providing adequate insulation
11. Choosing a proper shape and geometry for the system
12. Providing easy access to the structure for periodic inspection, maintenance, and replacement of damaged parts
13. Eliminating grounding of electrical circuits to the system (Many plumbing codes for water systems are outdated and allow undesirable situations to exist. Such codes may even create problems, for example, by requiring lead joints in some piping. Where such problems exist, it may be helpful for the utility to work with the responsible government agency to modify outdated codes.)

11.3.5 Gas Industry

11.3.5.1 Types of Corrosion in Underground Piping

The problems of corrosion will be confined to the piping system, mainly underground. If the system contains restrained lines in an above-ground system that is subject to dust or sand movement, then the treatment of the piping will follow the underground system.

Corrosion in other parts of the system, such as the compressors and processing equipment, is discussed in other industrial sections such as Section 11.3.3.2. Corrosion in compressor station equipment is handled by water treatment and inhibition of the cooling waters and is not of major concern to corrosion experts in the gas industry. Processing vessels are handled similarly to the equipment covered in the petroleum industry by the use of inhibitors. Corrosion coupons and equipment inspection are used to monitor corrosion rates in the equipment.

The prevalent corrosion problems of underground piping systems are galvanic and differential concentration cells common to ferrous metals in soils and natural waters with resultant pitting-type corrosion. A serious problem can result in certain areas from stray DC current interference from nearby coal mines, street railways, and industrial use of Earth-grounded DC power. Bacterial or microbiological corrosion is generally thought to be a serious

and common contributor to underground and natural water corrosion problems in underground systems.

For production-gathering pipelines, internal blistering and cracks have occurred where the gas has a high hydrogen sulfide (H_2S) content.

In only a few cases has stress corrosion cracking or hydrogen stress cracking been a problem. Stress corrosion cracking occurred on the external surface of underground gas pipelines where there had been a mixture of nitrates, carbonates, and bicarbonates in the soil. Hydrogen stress cracking has occurred in localized areas of extreme hardness (hard spots) induced during manufacturing of the pipe by accidental localized quenching by water spills.

11.3.5.2 Methods of Control

The main methods of corrosion control on underground pipelines include:

- Complete coating of the underground piping
- Cathodic protection
- Insulated fittings at strategic points
- Mitigation of stray currents via insulation of control bonds to the source of the stray current

The National Association of Corrosion engineers (NACE) issued a pamphlet entitled Recommended Practice RP-01-69, "Control of External Corrosion of Underground or Submerged Metallic Piping Systems," presenting the procedures and practices that are presently in use in the gas industry. Contact can be made at 1440 South Creek, Houston, Texas 77084.

The Department of Transportation Office of Pipeline Safety has issued minimum safety standards that contain minimum corrosion requirements for pipeline facilities carrying natural gas. This is labeled as Subpart 1 of Part 192, Title 49, *Code of Federal Regulations*.

11.3.6 Pipeline Industry

The more common means of corrosion control for the pipeline industry are discussed in the following paragraphs.

11.3.6.1 Coatings

The first approach to corrosion control used in the pipeline industry involves the use of coatings. It was recognized early on that the corrosion process was of electrochemical origin, and it was logically reasoned that if the pipeline metal could be electrically isolated from its environment, there could no longer be a flow of current between separate points on the

surface of the pipe and that, as a result, corrosion would be eliminated. This would be true if an electrically insulating coating could be installed that was 100% perfect at the time of installation and that could be maintained in a 100% perfect condition for the lifetime of the pipeline. This is not a practical possibility under the usual pipeline construction conditions. As a result, there will be a certain number of coating defects where the steel will be exposed to the pipeline environment. Although corrosion may still be stopped on better than 99% of the pipeline surface, any corrosion current that does flow will be concentrated at coating defects, and the rate of corrosion at these points may be such that pipeline penetration will occur at an earlier date than would have been the case had the pipeline been left bare (assuming coating to be the only method used).

11.3.6.2 Cathodic Protection

Once it was discovered that the use of coatings would not provide the total answer to pipeline corrosion, the technique of cathodic protection was introduced. This is an electrical method of combating corrosion in that any corrosive currents caused by contact between the pipeline and an electrically conductive ionic environment are prevented from discharging from the pipeline to the environment (with attendant corrosion) by nullifying them with a superimposed direct current flow from an external source. When accomplished, the entire metallic structure being protected is collecting direct current from its environment. By so doing, the entire structure is forced to become a cathode in the electrical circuit (and hence the name of this corrosion control method); and if the condition is fully satisfied, the corrosion will stop. Although cathodic protection can be applied to bare pipelines, the amount of current may be so great in the case of large-diameter long pipelines that in addition to the number and complexity of current sources necessarily installed along the pipeline, there is a potential problem with stray current from the high-capacity cathodic protection systems causing corrosion on adjacent underground metallic structures of other ownership. As a result of this, time has proven that the best practical combination (for use in the pipeline industry under normal conditions) is that of pipeline coating and supporting cathodic protection. As indicated earlier, a reasonably well-applied coating can be expected to protect better than 99% of the pipeline surface. With cathodic protection, current from the cathodic protection system flows only to less than 1% of pipe surface that involves bare metal contacting the earth. As a result, a single cathodic protection installation can, under normal circumstances, protect many miles of big-inch-diameter coated pipeline with a minimum amount of current by combining the two methods (i.e., coating and cathodic protection).

11.3.6.3 Internal Corrosion

Although external corrosion is a problem throughout the length of any buried or submerged pipeline, internal corrosion is a problem only if the material being carried by the pipeline is of a corrosive nature. When the material being carried by a pipeline is determined to be corrosive in nature, it may be possible to treat the material to inhibit the corrosive properties. Where inhibitors are used, it is necessary to monitor the effectiveness of the corrosion control method by, for example, using internal coupons that can be examined at intervals in order to evaluate the effectiveness of the treatment method.

When treatment is not possible, the use of an internal coating system may be resorted to. In petroleum or petroleum products, it is possible to apply paint coatings in place on existing pipelines. Although any paint or coating system applied internally may not be 100% effective, it will nevertheless materially reduce the amount of internal pipeline surface that is directly affected by the material being carried. In the case of water pipelines, good experience has been obtained, where internal corrosion is a significant problem, by the use of linings of cement mortar that can be applied to pipelines already in place. In other situations where conditions warrant it, good experience has been obtained with inserting plastic liners (of a type that is not affected by the material being transported) inside the original metallic pipe when it approaches the point of becoming unserviceable because of internal corrosion. This approach is normally applicable to lower pressure pipelines.

In some instances it is possible to eliminate corrosion problems in the design stage by selecting a material of construction that will be compatible with the media being transported. Alternate materials other than an alternative metal may include one of the several plastic piping materials, many of which are suitable for burial, providing pressure is not a limitation.

Where a substitute metal is suitable from the viewpoint of corrosion resistance and is competitive on an overall cost basis, this may be a suitable choice. Materials other than metals suitable for use in the pipeline industry include the following:

- Asbestos cement
- Reinforced concrete
- Plastic
- Filament-wound reinforced plastic pipe

11.3.7 Marine Industry

One of the outstanding methods of protection for marine objects in seawater is cathodic protection. The combination of organic coatings and cathodic protection has given military and merchant shipping plus offshore oil-well towers much better corrosion control over corrosion problems than prior to

World War II. Certainly cathodic protection of large areas is not economical unless these areas are coated. The techniques of surface preparation, primer formulation, anticorrosion paint systems, and removal of fouling organisms from the hulls and other undersea surfaces are of prime importance.

Zinc anodes, as sacrificial anodes, have been used successfully for protecting sea chests of saltwater piping systems. When the sea chest is steel and the valve is nonferrous, a waster sleeve of mild steel is recommended as additional protection. Mixed ferrous and nonferrous systems should be designed to include a waster piece of extra-heavy galvanized steel on the nonferrous section, connected in such a way as to afford easy removal.

For protection against corrosion in stagnant systems, such as bilge pump strainers and valves where various combinations of steel, stainless steel, and bronze occur, a zinc anode should be used. One rule of thumb is 1 ft² of zinc anode for each 50 ft² of bare metal.

For cupronickel piping, corrosion and erosion-corrosion are minimized by having maximum flow rate (limited to 15 f/s) and by reducing or eliminating air. During idle periods (1 week or more in duration), the saltwater piping system should either be drained or operated daily.

11.3.7.1 Protection of Condensers and Saltwater Exchangers

For condensers and exchangers, corrosion control measures involve design, material selection, fabrication, and maintenance. Designs avoid erosion corrosion by paying attention to the configuration of waterboxes and injection piping. Specifications generally require limiting the flow rate of either seawater or brine flow to 15 ft/s for both 70–30 and 90–10 cupronickel to minimize the effects of erosion-corrosion.

If at all possible, avoid operating a condenser in polluted water.

During shutdown there is a tendency for seawater to pocket, especially in the sagging section of tubes. Such pocketing causes serious corrosion and can be avoided by washing with freshwater and then drying out (using an air lance to empty sagging tubes). If the condenser cannot be completely dried out during shutdown, it should be filled completely with freshwater.

Stones, pieces of wood, shells, etc. lodging in condenser tubes cause pitting corrosion. These are removed periodically by the use of a water lance, soft rubber plugs driven through by an air gun or by a rotating bristle brush. Wire brushing and abrasive cleaning of condenser tubes are specifically prohibited because these remove all the protective coating.

11.3.7.2 Use of Aluminum in Marine Service

One of the first rules of using aluminum in seawater is to avoid machining the as-rolled or as-extruded surface if possible. The machined surface corrodes far worse than the unmachined surface. The second rule is to avoid using steel wool or wire brushes, other than stainless steel, on aluminum. Sanding

may be done if needed but avoid using abrasive discs or other nonmetallic scouring pads that have been used to remove paints that contained copper or mercury anti-fouling compounds. Wood or plastic scrapers are preferred.

The most common causes of galvanic corrosion problems of aluminum in ships are placing an aluminum deckhouse on a steel support and attaching steel or copper-based alloys to the hull or the piping, or both. These more noble metal fittings should be electrically insulated from the aluminum; even so, waster-plate practice is recommended. Cathodic protection is recommended where copper alloys are involved, even though the copper alloy is electrically insulated from the aluminum, because there is a degrading effect from the simple proximity of the copper alloy to the aluminum alloy.

Unlike steel, aluminum cannot be made thermodynamically stable in seawater by cathodic protection methods. Nevertheless, cathodic protection is highly effective because it counteracts any tendency toward localized hydrolytic acidification with its attendant breakdown and passivity. Only zinc (MIL A-18001) and certain aluminum-based galvanic anodes are permitted; magnesium anodes and mercury-bearing aluminum anodes are prohibited for aluminum hulls.

Cleanliness is always important, as both solid particles and grease marks invite localized hydrolytic acidification and consequent local film breakdown. Regular freshwater washdown of decks and bilges is helpful in removing solid debris and in keeping down the concentration of chloride, which plays an essential role in hydrolytic acidification.

Paint coatings play an important role in controlling hull corrosion. It is standard practice to have a 2-mil primer, followed by a 2-mil antifouling paint containing either copper or mercury. An organotin compound is presently the preferred toxicant in antifouling paint for aluminum hulls.

Where there are threaded bolts or fittings of aluminum exposed to seawater, 50% zinc dust in petrolatum can be used on the threads as an anti-seize lubricant. Graphite-, lead-, or tin-bearing lubricants must be avoided. Stainless steel lock nuts and washers are usually acceptable on such aluminum components.

Standard stipulations for aluminum alloys for marine atmosphere service call for "stress-corrosion-resistant alloys," without, however, specifying the test. Where cadmium-plated bolts or nuts are used with aluminum alloy parts, they are preferably isolated from the aluminum with aluminum alloy washers under the bolt head and nut, but cadmium-plated washers may be used for bolts under high tension. The usual precautions against stress concentration (i.e., shot preening and stress relieving) are recommended where feasible to minimize stress corrosion. In highly textured alloys, a rule of thumb is to keep working stress in the longitudinal direction less than 50% of the yield, 35% in the long transverse direction, and 25% in the short transverse direction. Aluminum-hulled boats should be provided with non-conducting mooring lines when next to steel ships and piers, and insulating camels should be used.

The corrosion control technology of offshore structures tends to make use of developments in corrosion control for ships. Many offshore ancillary components are protected by galvanic anodes previously proven out on ship hulls.

Index

A

- Abrasion resistance, in tank linings, 177
- Abrasive blast cleaning, 252
 - multilayer paint systems requiring, 246
 - as pretreatment, 223
- Abrasive cleaning, for metal surface preparation, 222
- Absorption
 - of liquids by PFA, 165
 - and polymer corrosion, 163–166
 - of selected liquids by FEP, 164
 - in sheet linings, 190–191, 193
 - water rates in polymers, 164
- Acid pickling, 58, 63
 - inhibition of, 316
- Acid solution
 - chemisorption in, 320
 - inhibition in, 318–319
 - interactions between adsorbed inhibitors, 321
 - physical adsorption in, 319
 - relationships between inhibitor reactivity and efficiency, 321
- Acid waters, in water distribution systems, 363
- Acidic chemical exposure, paint systems for, 251–252
- Acids/bases
 - hard and soft, 94, 95
 - in petroleum refining, 360
- Acrylic, 139, 140
- Activation overpotential, 258, 259, 260
- Activation polarization, 15–16
 - hydrogen electrode, 17
- Active-passive behavior, 21
 - anodic polarization curve, 21
 - schematic representation, 22
- Active pigments, 202, 203
- Additives, in paint, 204–206
- Adhesion failure, 212, 216, 217
 - due to water, 214
- Adhesion tests, 240
- Adsorbed inhibitor interactions, 321
- Adsorption layers
 - and metals corrosion, 90–92
 - and time of wetness, 80–81
- Air drying, as curing method, 239
- Air quality standards, 230
- Airless spray systems, 232
- Alacamate, 265
- Alclad coatings, 120
- Aldehydes, as organic inhibitors, 315
- Alkali metals, 166
- Alkaline cleaning, for metal substrates, 223
- Alkaline earth metals, 166
- Alkaline solutions, inhibition, 323
- Alkyds, 179
- Alligatoring, 207
- Alloy content, 73
 - effects on anodic polarization behavior, 23
 - and LME, 71
- Alloys
 - critical corrosion temperatures, 39
 - galvanic series, 37
 - intergranular corrosion in, 35
 - and selective leaching, 56
 - as steel bottom replacement in vessels, 174
- Aluminum
 - anodic polarization, 21
 - anodic undermining, 217
 - anodizing of, 296
 - crevice corrosion, 39
 - passive film on, 30
 - pretreatment, 224
 - use in marine service, 375–377
- Aluminum alloys
 - alclad coatings, 120
 - anodic coatings, 120
 - anodized coatings, 121
 - applications, 121–122
 - barrier coatings, 120–121
 - corrosion resistance, 116–120
 - paints, 121
 - protective measures, 120–121
 - SCC of, 47

- Aluminum coatings, cathodic control, 289
- Ambient temperature, 332
 - and liner selection, 186
- American Petroleum Institute (API), 359
- Amines, as organic inhibitors, 315
- Ammonia, 100
 - production by MIC, 54
 - in rural atmospheres, 111
- Amphoteric metals, risks in impressed current systems, 305
- Anionic inhibitors, 315
- Anode materials, 303
 - impressed current systems, 304–305
- Anode polarization measurement, 20
- Anodes, 6, 36
- Anodic coatings, 120
- Anodic control protection, 255, 262, 263
 - by noble metals, 267–276
- Anodic deposition, 234
- Anodic efficiency, metals for cathodic protection, 300
- Anodic electrodeposition, 236
- Anodic overpotential, 257
- Anodic polarization, 19, 22, 257
 - effects of environment and alloy content on, 23
 - measurement, 21–22
- Anodic polarization curve, 20
- Anodic reaction resistance, 258
- Anodic Tafel coefficients, 260
- Anodic undermining, under organic coatings, 217
- Anodized coatings, 121, 295–296
- Antisweat service, 350–351
- Application. *See* Coating application
- Applied exterior wood finishes, 151–153
- Arctic environments, 329
- Asbestos-containing paints, 230
- ASME Boiler and Pressure Vessel Code, 359
- Asphalts, 178
- Atmospheric corrodents, 96–97
 - carbon dioxide, 101
 - chlorine compounds, 100
 - indoor and outdoor ranges, 101
 - indoor atmospheric compounds, 101
 - nitrogen compounds, 99–100
 - oxygen, 101
 - sulfur compounds, 97–99
- Atmospheric corrosion, 31, 77–78
 - aluminum alloys resistance to, 116–122
 - atmospheric types and, 78–79
 - carbon dioxide and, 101
 - carbon steel resistance to, 102–103
 - of ceramics, 141–145
 - chlorine compounds and, 100
 - copper alloys resistance to, 114–116
 - copper resistance to, 112–114
 - corrosion products and, 86–87, 94–96
 - cost of protection, 1
 - design considerations, 336–337
 - designing protection against, 335–336
 - as discontinuous process, 79
 - of elastomers, 133–134
 - factors affecting, 79–89
 - Inconel alloys resistance to, 125–126
 - indoor, 153–154
 - indoor atmospheric compounds and, 101
 - initial exposure and, 85
 - of masonry materials, 134–141
 - mechanisms in metals, 89–94
 - Monel alloy resistance to, 125
 - nickel resistance to, 125
 - nitrogen compounds and, 99–100
 - of nonmetals, 126–154
 - oxygen and, 101
 - of plastics, 126–132
 - pollutants and, 87–89
 - resistance of specific metals and alloys to, 102–126
 - sheltering and, 85–86
 - specific corrodents, 96–101
 - staggering costs of, 77
 - stainless steel resistance to, 122–125
 - of steel, 349
 - structural considerations, 337–338
 - sulfur compounds and, 97–99
 - surface electrolyte composition and, 83–84
 - of synthetic materials, 77
 - temperature and, 84–85
 - time of wetness and, 80–83
 - weathering steels resistance to, 104–106

wind velocity and, 86
of wood, 145–153
zinc resistance to, 106–109, 283
zinc/zinc alloy coatings on steel
 resistance to, 109–112
Atmospheric types, 78–79
Attack localization, by inhibition, 324
Austenite stabilizers, 29
Austenitic stainless steel
 corrosion resistance, 123–124
 inhibition of SCC in, 325
 intergranular corrosion in, 32–35
 passive film on, 29
 protective coating before insulation,
 352
 SCC in, 47
 transgranular cracking, 49
Automobile cooling systems, inhibition
 processes in, 309
Automobile fuel tanks, terneplate in, 276
Automotive bodies, paint coating
 systems, 235, 236
Autotrophs, energy source, 51
Aviation, MIC in, 53

B

Backfill, 303
 impressed current systems, 304–305
Bacterial corrosion, in gas industry, 371
Baking method, curing by, 239
Barrier coatings, 120–121, 198, 292, 294
Barrier pigments, 203
Basic carbonate, 113
Basic chloride, 113
Basic copper salts, 264, 265
Basic nitrate, 113
Basic sulfate, 113
Basic zinc salts, 107
Binder, 200–201. *See also* Resin
Biological corrosion, 50–54
 preventive measures, 54–55
Biological growths, and corrosion, 24
Blast cleaning, 221
 banning of silica sand in, 222
Blistering, 204, 210, 218
 in gas industry, 372
 initiation and propagation under
 organic coatings, 216

 under organic coatings, 215
Blocking pigments, 201
Bolted joints, avoiding, 173
Bond failures, 208, 212
 causes, 206
Bond strength, and relative humidity,
 208
Bonded linings, 186–187
Borax, as inhibitor in antifreeze
 solutions, 315
Boric acid, as electrolyte, 296
Borohydride, as reducing agent, nickel
 coatings, 270
Brasses, corrosion resistance, 114–116
Bright nickel deposits, 267
Brittle points, common elastomers, 138
Brochonite, 265
Bronzes, corrosion resistance, 116
Brush-off blast cleaning, 221
Butt welding, 187
 for liquid applied linings, 172
 for shell design, 184
Butyl rubber, 178, 195

C

Cadmium, surface pretreatment, 225
Cadmium coatings, cathodic control,
 289–290
Calcium oxide, 134
Calcium silicate, 344
 as insulation material, 345
Canal gates, cathodic protection in, 298
Capillary forces, 214
Carbide precipitation, 32, 35
 effect of carbon content on, 33
Carbon-chlorine bond, 166
Carbon content, effect on carbide
 precipitation, 33
Carbon dioxide
 as atmospheric corrodent, 101
 in surface electrolyte, 84
Carbon-fluorine bond, 128
Carbon-hydrogen bond, 128, 166
Carbon steels, 86
 corrosion by type of atmosphere, 341
 corrosion resistance, 102–103
 design considerations for protection,
 340–342

- low-alloy, 104
- protective coating before insulation, 352
- resistance to pitting, 42
- SCC in, 47
- Carbonate precipitation, 322
- Carbonic acid, 134
- Cast iron
 - resistance to erosion corrosion, 45
 - selective leaching, 57
- Cast zinc alloys, corrosion resistance, 112
- Cathodes, 6, 36
- Cathodic control protection, 255, 262, 263, 278
 - aluminum coatings, 289
 - cadmium coatings, 289–290
 - manganese coatings, 290
 - by sacrificial metal coatings, 277–290
- Cathodic delamination, under organic coatings, 216
- Cathodic electrodeposition, 236
- Cathodic inhibitors, 317
- Cathodic overpotential, 257
- Cathodic polarization curve, 15, 20, 257
 - effects of corrodent velocity on, 24
- Cathodic protection, 6, 54, 57, 75, 297–298
 - anode materials and backfill, 303–306, 304–305
 - with copper alloys, 376
 - copper-zinc cell polarization
 - example, 238, 239
 - current requirements, 304
 - for Galvan and galvanized coatings, 287
 - in gas industry, 372
 - graphite anodes in, 303
 - impressed current, 299, 303–304
 - local action cell, 239
 - in marine industry, 374
 - pipeline industry, 373
 - platinum-clad electrodes in, 303
 - sacrificial anodes, 300–302
 - scrap iron use in, 303
 - and Sunde equation, 302
 - theory, 298–306
 - use with coatings, 306–307
 - in water treatment and supply systems, 370
- Cathodic reaction resistance, 258
- Cathodic Tafel coefficients, 260
- Cationic inhibitors, 315
- Caustic embrittlement, 46
- Cavitation, 45, 46, 324
 - in ceramics, 143–144
- Cell potentials, 7–8
- Cellular glass, 345
 - as insulation material, 347
- Centrifugal casting, 233
- Ceramics
 - atmospheric corrosion resistance, 146
 - corrosion of specific, 145
 - corrosion resistance, 141–143
 - forms of corrosion, 143–145
- Chalking, 207, 210
- Chelating agents, for near-neutral solutions, 323
- Chemical disbondment, 215
- Chemical equipment, cathodic protection in, 298
- Chemical failures, 213
- Chemical industry, 356
 - coverings and liners, 357
 - design improvements, 358
 - environmental changes, 357
 - inhibitors, 357
 - materials selection, 356
 - regular inspection and improved techniques, 358
 - specifications for purchasing and/or contractors, 358
- Chemical processing, MIC in, 53
- Chemical treatment, plastic substrate preparation, 227–228
- Chemically resistant pigments, 202
- Chemisorption, in acid solution, 320
- Chemotrophs, energy source, 51
- Chloride attack, 330
 - minimizing in insulation systems, 343
 - reducing risk in marine industries, 376
- Chlorides
 - and atmospheric corrosion of zinc, 110
 - effects on steel corrosion, 315
 - in surface electrolyte, 84
- Chlorine compounds

- as atmospheric corrodents, 100
- effect on zinc coatings, 284
- Chlorobutyl rubber, 195
- Chlorotrifluorethylene (CTFE), 128
- Chromate coatings, 292–294
 - cautions with antifreeze solutions, 314
 - as inhibitors, 313
 - use in recirculating applications, 314
- Chromate concentration, effects on steel corrosion, 315
- Chromic acid, as electrolyte, 295
- Chromium
 - anodic polarization, 21
 - in austenitic stainless steels, 123
 - in ferritic steels, 124
 - as stabilization agent, 29
 - in weathering steels, 105
- Chromium carbides, 32
- Chromium coatings, 271–273
- Cladding, 72
- Coal tar, 178
 - in water storage applications, 365–366
- Coalescing mechanism, in air drying, 239
- Coating application, 229–230
 - application methods, 230–235
 - avoiding failures, 207
 - brushing technique, 231
 - curing methods, 238–240
 - electrodeposition of polymers, 234–235
 - inspection role, 240–241
 - multilayer coatings, 235–237
 - powder coating technique, 233–234
 - roller coating technique, 231
 - rolling technique, 231
 - spray painting technique, 232–233
- Coating failures
 - causes, 206
 - cohesive failure, 212
 - due to atmospheric effects, 207–209
 - and strength of paint film, 210–212
 - stress and chemical failures, 213
 - surface preparation and application to avoid, 207
 - types of, 210–213
- Coating maintenance, 241
- Coating thickness, zinc coatings, 281
- Coatings, 67, 75
 - causes of failure, 182–183
 - chemical industry, 357
 - as engineering function, 197
 - in pipeline industry, 372–373
 - preventing hydrogen attack with, 65
 - synthetic *vs.* organic, 198
 - two-component, 240
 - use in impressed current systems, 306–307
 - uses in lining, 180
 - water storage tanks, 368
 - in water treatment and supply systems, 365–366
- Cohesive failure, 212
- Cold service, 352
 - design considerations, 351–353
- Color change, 210
- Color pigments, 202
- Colorimetric test, 306
- Commercial blast cleaning, 22
 - multilayer paint systems requiring, 24–245
- Communication cables, cathodic protection in, 297
- Concentration cells, 8, 9–10, 41
 - formation by microbes, 53
- Concentration overpotential, 258, 259, 260, 262
- Concentration polarization, 17–18
 - curve for reduction process, 18
 - in hydrogen evolution reaction, 18
- Concrete
 - atmospheric resistance, 141
 - corrosion resistance/protection, 137–138
- Concrete tanks, 176
- Condensers
 - cathodic protection in, 298
 - protection issues, 375
- Conservation losses, 3
- Contamination, 2
 - in dew, 81
 - and filiform corrosion, 217
 - and polymer degradation, 169
- Control rooms, design considerations, 339–340
- Conversion coatings, 291, 294

- Conversion factors, 26
- Conversion mechanism
 - in air drying, 239
 - in baking cures, 239
- Cooling water, in petroleum refining, 360
- Copper
 - corrosion resistance, 112–114
 - in impressed current systems, 305
 - passive film on, 29
 - pretreatment, 224
 - in weathering steels, 105
- Copper alloys, 35
 - brasses, 114–116
 - bronzes, 116
 - corrosion resistance, 114
 - SCC in, 47
- Copper coatings, mechanism of control protection, 264–265
- Copper-gold system, 266
- Copper-nickel alloys, 116
- Copper undercoat, 265
- Copper-zinc cell, cathodic protection in, 298, 299
- Corrodent velocity, 24
- Corrosion
 - activation and concentration overpotentials in, 259
 - annual cost of, 1
 - attack on nonmetallic materials, 4
 - cost of, xxiii
 - defined, 5
 - direct losses, 1–2
 - electrochemical basis, 255
 - indirect losses, 2–3
 - kinetically limited, 142
 - by liquid metals, 72–73
 - mechanisms of, 4
 - metallic, 4
 - metallic coatings, 255
 - miscellaneous factors affecting, 23–24
 - of paint, 197–198
 - physical, in thermoset polymers, 167
 - rate of, 6
 - rationale for study of, 1
 - stages of, 218–220
 - susceptibility to, 4
 - in zinc coatings, 283–285
- Corrosion allowance, 3, 31, 337
- Corrosion-assisted cracking, in ceramics, 144
- Corrosion cells, 255–263, 277
 - mechanism, 257
 - and standard single potentials, 258
 - structure, 256
- Corrosion controls, 262, 263
 - anodic control, 263
 - cathodic control, 263
 - mixed control, 263
 - resistance control, 263
- Corrosion current, 257
- Corrosion density, 14
- Corrosion fatigue, 24, 41, 48, 74–75, 326
 - preventive measures, 75
- Corrosion inhibitors, 309–310
 - chelating agents and metal protected, 323
 - chromate concentration, chlorides, and mild steel corrosion, 315
 - classification, 311–318
 - inhibition in acid solution, 318–321
 - inhibition of alkaline solutions, 323
 - inhibition of localized corrosion, 324–326
 - inhibition of near-neutral solutions, 321–323
 - inhibitor evaluation, 310–311
 - organic inhibitors, 315–317
 - passivation inhibitors, 311–315
 - passivator concentration effects on iron, 312
 - in petroleum refining industry, 362
 - precipitation inhibitors, 317
 - temporary protection with, 323–324
 - vapor-phase inhibitors, 317–318
- Corrosion losses, sacrificial metal coatings, 280
- Corrosion mechanisms, 4, 5–6
 - cell potentials, 7–8
 - and corrosion rate measurement, 25
 - local cell formations, 8–11
 - miscellaneous factors, 23–24
 - polarization, 14–18
 - and polarization measurement, 19–22
 - potential-pH diagrams, 11–14
- Corrosion monitoring techniques, 4
- Corrosion potential, 257

- Corrosion products, 30, 49, 73, 94–96
 - amorphous or crystalline, 86
 - nature of, 86–87
 - on sacrificial metal coatings, 278
 - secondary barrier action, 264
 - stability and composition, 14
 - on zinc, 107
 - Corrosion properties, in water
 - distribution, 369
 - Corrosion rate
 - initial, copper coating, 265
 - measuring in inhibition processes, 311
 - role in equipment design, 329
 - zinc coatings, 283
 - Corrosion rate measurement, 25
 - corrosion rate expressions, 25
 - Corrosion resistance, 102
 - in aluminum alloys, 116–122
 - in carbon steel, 102–103
 - in cast zinc alloys, 112
 - in copper, 112–114
 - in copper alloys, 114–116
 - in copper-nickel alloys, 116
 - in duplex-grade stainless steel, 125
 - in ferritic stainless steels, 124
 - Inconel alloys, 125–126
 - in martensitic stainless steels, 124–125
 - in materials of construction, 333
 - in Monel alloy, 125
 - in nickel, 125
 - in stainless steels, 122–125
 - of steels, 340
 - terneplate, 276
 - in weathering steels, 104–106
 - in zinc, 106–109
 - in zinc alloy coatings on steel, 109–112
 - in zinc-aluminum hot dip coatings, 111
 - in zinc-aluminum thermally sprayed coatings, 111–112
 - in zinc-iron alloy coatings, 112
 - Corrosion-resistance properties, 4
 - Corrosion testing techniques, 4
 - Corrosion under insulation (CUI), 342
 - insulation design characteristics, 344–348
 - insulation material selection, 342–344
 - Corrosion zone, 13
 - Coupon test, 306
 - Cracking, 207
 - Crevice corrosion, 38–40
 - in ceramics, 143
 - critical crevice corrosion
 - temperatures, 39
 - preventive measures, 40–41
 - Crevices, avoiding in equipment design, 337
 - Critical corrosion temperature, 39
 - Critical pitting temperature (CPT), 43
 - Critical relative humidity, 80, 90
 - Crude oil, pretreatment of, 361
 - Crude selection, 361
 - Cryogenic service, 353
 - Crystallinity
 - and permeation rate, 189
 - and stress corrosion cracking, 169
 - Curing, 201
 - air-drying method, 239
 - baking method, 239
 - force drying method, 240
 - of liquid applied linings, 182
 - and polymer resistance, 168
 - radiation curing method, 240
 - reflowing method, 240
 - vapor curing method, 240
 - Current flow, 6
- ## D
- Damp atmospheric corrosion, 90–92
 - Daniel cell, 9
 - DC current interference, 371
 - Debonding, in sheet linings, 193
 - Delamination, 207
 - Delayed failure, and LME, 72
 - Depolarization, with passivation inhibitors, 311
 - Deposition rate, 98
 - Design considerations, 335
 - antisweat service, 350–351
 - atmospheric corrosion, 336–337
 - carbon steel protection, 340–342
 - cold service, 351–353
 - control rooms, 339–340
 - corrosion under insulation, 342

- cryogenic service, 353
 - electrical components, 339
 - hot service, 354
 - insulation material, 342–348
 - jacketing, 348–350
 - pipng systems, 354–355
 - special environments, 354
 - structures, 337–338
 - tank design, 355
 - Detergent cleaning
 - for metal substrates, 222
 - plastic substrates, 226–227
 - Dew
 - and atmospheric corrosion, 81
 - and wet atmospheric corrosion, 92
 - Dezincification, 55, 56, 324, 325
 - Differential aeration cell, 10
 - Differential temperature cells, 8, 10
 - Direct dissolution, 73
 - Direct losses, 1–2
 - Disbondment, 219
 - Dissimilar electrode cells, 8, 9
 - Dissimilar metal corrosion, 36
 - Dissociative absorption, 95
 - Dissolution reactions, 16
 - Dissolved oxygen (DO), 365
 - Dry deposition velocity, 86, 93, 94
 - sulfur compounds, 98
 - Ductility
 - loss of, 58, 59–60
 - and selection of materials of construction, 333
 - in steel, 60
 - Dull bright nickel deposits, 267
 - Duplex-grade stainless steels, corrosion resistance, 125
 - Duplex nickel electrode deposit, 272
 - Dust, and atmospheric corrosion, 82
- E**
- Eclipse molding framework (EMF)
 - control protection. *See* EMF control protection
 - Economic considerations, materials of construction, 334
 - Economic losses, 1–2
 - Edge failures, 207
 - Efficiency losses, 3
 - Elastomeric linings, 194–195
 - Elastomers, 78
 - ASTM designations, 133
 - atmospheric corrosion in, 133–134
 - atmospheric resistance, 135
 - brittle points, 138
 - low-temperature flexibility, 137
 - operating temperature ranges, 136
 - Electrical components, design considerations, 339
 - Electrochemical corrosion, 255
 - Electrochemical reactors, stimulation by microbes, 54
 - Electrochemical series, 256
 - Electrodeposition
 - anodic and cathodic, 236
 - nickel coatings, 269
 - polymers, 234–235
 - Electroless plating
 - gold-copper, 266
 - nickel coatings, 269
 - Electrolyte layer inhibition, 310
 - Electrolytes, and phase layers, 81
 - Electron transfer, 15
 - in chemisorption, 320
 - Electronic applications, gold coatings in, 266
 - Electronic resistance, 200
 - Electroplating process, tinplate, 273
 - Electrosorption valency, 319
 - Electrostatic fluidized bed, 233, 234
 - Electrostatic powder spraying, 233
 - Electrostatic spray coating, 234
 - Elemental transfer, 73
 - EMF control protection, 255, 263, 296
 - by noble metals, 264–266
 - Emulsion cleaning, metal substrates, 223
 - Environment, 253
 - and current density requirements for impressed current systems, 304
 - effect on concentration polarization curve, 18
 - effects on anodic polarization behavior, 23
 - role in selecting paint system, 242
 - and selective leaching, 56
 - Environmental cracking
 - in polymers, 169

- in sheet linings, 193–194
 - Environmental damage, 3
 - EPDM rubber, 195
 - Epoxy, 139, 140, 167, 178
 - Epoxy esters, 179
 - Equipment design process, 329
 - application considerations, 329–332
 - chemical industry, 356–358
 - controlling corrosion by design, 335
 - corrosion under insulation, 342–355
 - gas industry, 371–372
 - industries and systems covered, 355–356
 - marine industry, 374–377
 - materials of construction selection, 332–335
 - petroleum refining industry, 358–363
 - pipeline industry, 372–374
 - protection from atmospheric corrosion, 335–342
 - water treatment and supply systems, 363–371
 - Erosion corrosion, 44–45, 210, 324
 - in ceramics, 144
 - preventive measures, 45–46
 - Evans diagram, 256
 - Exfoliation, 73–74, 119
 - preventive measures, 74
 - Expanded perlite, 344
 - as insulation material, 345–346
 - Exposure time, and relative humidity, 208
 - Extenders, 203
 - in paint, 206
 - External current, use in cathodic protection, 298
 - Extreme pH exposure, paint systems for, 252–253
 - Extreme thermophiles, 52
- F**
- Fabrication costs, 334
 - Fabrication techniques, 4
 - Ferric alloys, SCC in, 47
 - Ferric chloride solution, 39
 - Ferritic stainless steels, 35
 - corrosion resistance, 124
 - Fiber-reinforced plastic (FRP) materials, 338
 - enclosures for electrical components, 339
 - Fiberwood, 150
 - Filiform corrosion, 75–76
 - under organic coatings, 217
 - preventive measures, 77
 - Fisheyes, 63
 - Flakes, 63, 207
 - Flanged outlets, 174, 184
 - Flash rusting, 218
 - Flexible elastomer, 345
 - as insulation material, 347
 - Fluidized bed procedures, 233
 - powder coating, 234
 - Fluorocarbons, as sheet linings, 183
 - Fluoroelastomers, 195
 - Fluoropolymers, 166, 167, 178
 - relative gas permeation, 162
 - as sheet linings, 187
 - Fog
 - and atmospheric corrosion, 82
 - and wet atmospheric corrosion, 93
 - Foods and beverages
 - cadmium coating warnings, 290
 - tin coating suitability for, 274
 - Force drying, curing by, 240
 - Formaldehyde, 101
 - Formic acid, 101
 - Fouling, materials of construction, 334
 - Free energy change, 7
 - Freshwater exposure, paint systems for, 250
 - Freshwater immersion, paint systems for, 251
 - Fretting corrosion, 45
 - Fungi, wood-destroying, 148
 - Furan, 140, 169
 - as lining material, 179
- G**
- Galfan coatings, 111, 285
 - comparison of cathodic protection, 287
 - exposure in marine atmosphere, 286
 - Galvalume, 111, 286, 287

- exposure in marine and industrial atmospheres, 288
 - Galvanic cells, 300
 - cathodic protection in, 298
 - Galvanic contact, avoiding in equipment design, 337
 - Galvanic corrosion, 9, 36–38, 267, 277, 290
 - of alloy tank linings, 174
 - in ceramics, 144
 - in marine industry, 376
 - preventive measures, 38
 - sacrificial metal coatings, 278, 279
 - Galvanic coupling, 9
 - Galvanic series, 38
 - metals and alloys in seawater, 37
 - Galvanically protective pigments, 201, 202, 203
 - Galvanized coatings, cathodic protection, 287
 - Galvanized steel, 109
 - comparison with Galfan coatings, 285
 - pretreatment, 224
 - Gas inclusions, 215
 - Gas industry, 371
 - methods of control, 372
 - and underground piping corrosion, 371–372
 - Gas permeation
 - into PFA, 161
 - relative, into fluoropolymers, 162
 - General corrosion, 27–32, 77
 - tin coatings, 274
 - Geometric effects, in localized corrosion, 324
 - Glass fiber, 344
 - as insulation material, 346
 - Glass-reinforced polyester, 338
 - Glass transition temperatures, organic films, 211
 - Glassy phosphates, 367, 368
 - Gold, stability in atmosphere, 5
 - Gold coatings, mechanism of control protection, 266
 - Grain boundaries, 32
 - Grain size, and LME, 71
 - Graphite, as sacrificial anode material, 303
 - Graphite corrosion, 56
 - Grouts, corrosion resistance, 140–141
 - Guanidine, as organic inhibitors, 315
- ## H
- Halogens, 30, 128
 - pitting associated with, 43
 - and thermoplast corrosion, 166
 - Hand-tool cleaning, 221
 - Hard and soft acids/bases, 94, 95
 - Hardwood
 - atmospheric resistance, 147–148
 - painting and weathering characteristics, 152
 - Hazardous waste, inhibition concerns, 313
 - Heat-affected zone (HAZ), 33
 - Heat treatment, 66
 - Heterotrophs, energy source, 51
 - Hexavalent chromium, 293
 - High-bake phenolics, 177
 - High humidity, 76
 - and filiform corrosion, 75
 - Highway maintenance, MIC in, 53
 - Holiday tests, 240
 - Holidays, 200
 - and need for cathodic protection, 297
 - Hot service, design considerations, 354
 - Hydride formation, embrittlement due to, 62
 - Hydrochloric acid, 5, 19, 100
 - Hydrofluoric acid, 30
 - Hydrogen, safe operating limits for steel in, 64
 - Hydrogen attack, 63–65
 - difficulty of detection, 359
 - in petroleum refining industry, 359
 - preventive measures, 67–68
 - Hydrogen blistering, 62–63
 - preventive measures, 65–66
 - Hydrogen damage, 57–58
 - fisheyes and, 63
 - flakes and, 63
 - and hydrogen attack, 63–65
 - and hydrogen blistering, 62–63
 - hydrogen embrittlement, 59–62
 - and hydrogen sources, 58–59
 - preventive measures, 65–68

- shatter cracks and, 63
 - types of, 59–65
 - Hydrogen electrode, activation
 - polarization curve, 17
 - Hydrogen embrittlement, 59–60
 - due to hydride formation, 62
 - due to microorganisms, 53
 - environmental, 62
 - and hydrogen stress cracking, 60–61
 - and loss of ductility, 59–60
 - preventive measures, 66–67
 - Hydrogen environment embrittlement, 62
 - Hydrogen evolution, 6, 15, 17, 18
 - Hydrogen overpotentials, metals, 261
 - Hydrogen peroxide, 97
 - Hydrogen reduction reaction, 16
 - Hydrogen sources, 58–59
 - Hydrogen stress cracking (HSC), 60–61, 61
 - Hydrogen sulfide, 99, 330
 - in petroleum refining, 359
 - Hydrolysis, of polymer materials, 157
 - Hydrotreating, in petroleum refining, 362
 - Hypalon, 178, 195
 - Hypophosphite, as reducer for nickel coating, 269
- I**
- Imines, as organic inhibitors, 315
 - Immunity, 142
 - Immunity zone, 13
 - Impingement, 45
 - Impressed current systems, 299–300, 303–304
 - anode materials and backfill, 304–305
 - colorimetric test, 306
 - coupon test, 306
 - current requirements, 304
 - potential measurements, 306
 - testing for completeness of protection, 305–306
 - Inconel alloys, corrosion resistance, 125–126
 - Indirect losses, 2–3
 - Indoor atmospheric compounds, 329, 331
 - as corrodents, 101
 - Indoor atmospheric corrosion, 153–154
 - Induction period, 85
 - Industrial atmospheres, 78, 329
 - austenitic steels in, 123
 - carbon steel corrosion in, 341
 - carbon steel in, 102
 - combined with marine, 331
 - copper corrosion rate in, 265
 - Galvalume exposure in, 288
 - nickel attack in, 270
 - steel corrosion in, 106
 - sulfur contamination in, 78
 - Inert anodes, 303, 304
 - Inert pigments, 202
 - Infrared energy, 126, 158, 208
 - Inhibition, 309
 - chemical industry design considerations, 357
 - mechanisms of action, 309, 310
 - Inhibitor reactivity-efficiency relationships, 321
 - Inhibitors, 43, 67, 374. *See also* Corrosion inhibitors
 - classification, 309, 311
 - evaluation, 310–311
 - modification by microbes, 54
 - preventing hydrogen attack using, 66
 - use in water treatment and supply systems, 366–368
 - Initial exposure, role in atmospheric corrosion, 85
 - Inspection, 336
 - chemical industry considerations, 358
 - coating applications, 240–241
 - Installation costs, reductions with cathodic protection, 307
 - Installation techniques, 4
 - Insulated fittings, 372
 - Insulation material
 - calcium silicate, 345
 - cellular glass, 347
 - design characteristics, 344–348
 - expanded perlite, 345–346
 - flexible elastomer, 347
 - glass fiber, 346

- melamine, 347
 - mineral fiber, 346
 - polyurethane/polyisocyanate foam, 346–347
 - preventing CUI with, 342–344
- Interface inhibition, 310
- Intergranular corrosion, 32, 35, 73, 77
 - in austenitic stainless steels, 32–35
 - in ceramics, 144
 - in ferritic stainless steels, 35
 - in miscellaneous alloys, 35
- Intermolecular chain forces, and
 - permeation rate, 189
- Internal corrosion, pipeline industry, 374
- Ion adsorption, at metal/solution
 - interface, 319
- Ionic resistance, 200
- Iron
 - anodic polarization, 21
 - corrosion in acid, 7
 - in hydrochloric acid, 5, 19
 - in impressed current systems, 305
 - in nitric acid, 21
 - passivator concentration effects on
 - corrosion, 312
 - passivators of, 316
 - passive film on, 28
 - polarization in acid, 15
 - role in protecting copper against
 - corrosion, 297
 - selective leaching of, 57
- Isophthalic polyester, 337

J

- Jacketing, 348
 - aluminum foil bonded to kraft paper, 348
 - fiberglass fabric laminated to PVC, 349
 - fiberglass fabric with hypalon rubber
 - and tedlar facing, 348
 - low-temperature mastic, 350
 - mastic asphaltic coating, 350
 - metal jacket-aluminum, 349
 - metal jacket-stainless steel, 349
- Joint welding, for liquid applied linings, 174

L

- Lacquers, 197
- Lap welding, 172
- Latex paints, 206
- Lead, in impressed current systems, 305
- Lead coatings, 276
- Lead paints, 230
- Lime, 134
- Limiting diffusion current density, 18, 261
- Lined piping, 187
- Lining application
 - chemical industry, 357
 - liquid applied linings, 181–182
- Lining corrosion, 171–172
 - elastomeric linings, 194–195
 - liquid applied linings, 172–183
 - sheet linings, 183–193
- Lining inspection, 191–192
- Lining selection
 - alkyds, 179
 - asphalts, 178
 - bonded linings, 186–187
 - butyl rubber, 178
 - coal tar, 178
 - elastomers, 195
 - epoxies, 178
 - epoxy esters, 179
 - fluoropolymers, 178
 - furan, 179
 - high-bake phenolics, 177
 - hypalon, 178
 - inorganic zinc, 179
 - for liquid applied linings, 176–181
 - modified air-dry phenolics, 178
 - modified PVC linings, 178
 - neoprene, 178
 - oleoresinous primers, 179
 - polysulfide, 178
 - PVC plastisols, 178
 - rubber latex, 178
 - for sheet linings, 185–187
 - styrene-butadiene polymers, 178
 - urethanes, 178
 - vinyl ester, 178
 - vinyl urethanes, 178
 - vinylidene chloride latex, 179
- Lining thickness

- and permeation, 188, 189
- in polymers, 162
- Linings
 - pipe wall, 367
 - in water treatment and supply systems, 365–366
- Liquid absorption
 - by FEP, 164
 - by PFA, 165
- Liquid applied linings, 172
 - avoiding pockets and crevices, 173
 - butt welding for, 172
 - causes of coating failure, 182–183
 - continuous welded joints, 174
 - cure of, 182
 - edge grinding, 174
 - lap welding, 172
 - lining application, 181–182
 - lining selection, 176–181
 - potential galvanic action, 176
 - stiffening member locations, 175
 - typical vessel outlets, 175
 - vessel design, 172–176
 - weld spatter removal, 173
- Liquid metal attack, 68
 - and corrosion by liquid metals, 72–73
 - liquid metal embrittlement (LME), 69–72
- Liquid metal embrittlement (LME), 68, 69
 - combinations summary, 70
 - delayed failure and, 72
 - factors influencing, 71–72
 - preventive measures, 72
 - requirements, 69, 71
- Liquid metal-induced embrittlement (LMIE), 68
- Lithotrophs, energy source, 51
- Load-carrying ability, 74
- Local cell formations
 - concentration cells, 9–10
 - differential temperature cells, 10
 - dissimilar electrode cells, 9
 - metal ion concentration cells, 11
 - oxygen concentration cells, 11
 - types of, 8
- Localized corrosion, inhibition, 324–326
- Location, design considerations, 336
- Lost production costs, 334–335
- M**
- Magnesium
 - as sacrificial anode, 301, 370
 - use in cathodic protection, 300
- Magnesium-based alloys, as sacrificial anodes, 300
- Magnetic oxide, 294
- Maintenance, 336
 - of coatings, 241
 - reduced costs with cathodic protection, 308
 - reduction with FRP materials, 338
- Maintenance costs, materials of construction, 334
- Malachite, 265
- Manganese coatings, 290
- Marine atmospheres, 78, 79, 329, 330
 - aluminum alloy use in, 122
 - aluminum corrosion in, 119, 289
 - austenitic steels in, 123
 - carbon steel corrosion in, 341
 - combined with industrial, 331
 - copper corrosion rates in, 113, 265
 - corrosion losses, sacrificial metal coatings, 280
 - Galfan and galvanized steel exposure, 286
 - Galvalume exposure in, 288
 - paint system selection, 250
- Marine industry, 374–375
 - protection of condensers and saltwater exchangers, 375
 - use of aluminum, 375–377
- Marine pilings, cathodic protection in, 298
- Martensitic stainless steels
 - corrosion resistance, 124–125
 - SCC in, 47
- Masonry materials
 - coating selection, 139
 - concrete protection, 137–138
 - corrosion resistance, 134–136
 - mortars and grouts, 140–141
 - polymer concrete, 140
- Materials of construction, xxiii, 329, 332
 - corrosion resistance, 333
 - cost of lost production, 334–335
 - ductility considerations, 333

- economic considerations, 334
- fabrication costs, 334
- fouling considerations, 334
- maintenance costs, 334
- and modulus of elasticity, 333
- physical properties, 333
- reliability requirements, 334
- repair costs, 334
- stress considerations, 333
- temperature considerations, 332–333
- toughness considerations, 333
- Materials selection
 - chemical industry, 356
 - petroleum refining industry, 359
- Maximum pit depth, aluminum alloys, 118
- Maximum surface temperature, 332
 - and sheet liner selection, 186
- Mears effect, 285
- Mechanical disbondment, 215
- Mechanical stress, 213
 - avoiding in equipment design, 337
- Mechanical treatment, plastic
 - substrates, 227
- Mechanical zinc coating, 282
- Melamine, 345
 - as insulation material, 347
- Membrane inhibition, 310
- Mercaptans, as organic inhibitors, 315
- Mesophiles, 52
- Metabolite production, by microbes, 53
- Metal deposition, 6
- Metal dissolution, 6
 - of less noble metals, 36
- Metal ion concentration cells, 11
- Metal ion reduction, 6
- Metal loss
 - due to chemical attack, 27
 - per unit time, 14, 31
- Metal protective paints, 203
- Metal substrate dissolution, in coating
 - defect, 267
- Metal substrate preparation, 197, 230–232
 - abrasive cleaning, 222
 - alkaline cleaning, 223
 - detergent cleaning, 222
 - emulsion cleaning, 223
 - solvent cleaning, 223
 - steam cleaning, 223
 - vapor degreasing, 223
- Metal surface pretreatment, 223–224
 - aluminum, 224
 - copper, 224
 - galvanized steel, 224
 - steel, 224
 - titanium, 224
 - zinc and cadmium, 225
- Metallic coatings
 - anodic control protection by noble metals, 267–276
 - cathodic control by sacrificial metal coatings, 277–290
 - corrosion, 255
 - corrosion cells in, 255–263
 - eclipse molding framework control protection, 296
 - EMF control protection by noble metals, 264–266
 - mixed control protection, 290–296
- Metallic corrosion, 27
 - biological corrosion, 50–55
 - crevice corrosion, 38–41
 - erosion corrosion, 44–46
 - exfoliation, 72–74
 - filiform corrosion, 75–76
 - galvanic corrosion, 36–38
 - hydrogen damage, 57–68
 - intergranular corrosion, 32–35
 - liquid metal attack, 68–73
 - pitting corrosion, 41–44
 - selective leaching, 55–57
 - stress corrosion cracking, 46–50
 - uniform corrosion, 27–31
- Metals
 - anodic efficiency, 300
 - atmospheric corrosion rates, 102
 - damp atmospheric corrosion, 90–92
 - hydrogen overpotentials, 261
 - life cycle predictions, 157
 - mechanisms of atmospheric corrosion, 89–90
 - pollutant deposition on, 93–94
 - practical energy constant, 300
 - role of cathodic protection in corrosion control, 297
 - surface orientation and corrosion, 93
 - theoretical energy content, 300

wet atmospheric corrosion, 92–94

Metalworking, MIC in, 53

Mica, as extender, 206

Microbial-induced corrosion (MIC), 50

- in gas industry, 371
- location by industry, 53

Microcracked chromium coating, 272, 273

Microorganisms

- chemical nutrition needs, 51
- temperature range and biological corrosion, 52
- in wood, 146

Microporous chromium coating, 272, 273

Mildew inhibitors, 206

Mineral fiber, 344

- as insulation material, 346

Mixed control protection, 255, 262, 263, 290–291

- anodized coatings, 295–296
- chromate coatings, 292–294
- oxide coatings, 294–295
- phosphate coatings, 291–292

Moderate thermophiles, 52

Modified air-dry phenolics, 178

Modified PVC polyvinyl chloracetals, 178

Modulus of elasticity, and materials of construction, 333

Moisture attack, in insulation systems, 344

Monel alloy, corrosion resistance, 125

Monolithic surfacings, 139

Mortars, corrosion resistance, 140–141

Multilayer coatings, 235–237, 267

- copper undercoat benefits, 265
- examples in steel structures, 237
- for new, clean surfaces, 249
- nickel, 270
- requiring abrasive blast, 246
- requiring clean surface, 248
- requiring commercial blast, 243

Multistage paint coating systems, for steel structures, 237

N

National Association of Corrosion Engineers (NACE), 372

National Institute of Standards and Technology (NIST), annual cost of corrosion, 1

Near-neutral solutions, inhibition, 321–323

Near-white blast cleaning, 221

Nelson curves, 64, 67, 359

Neoprene, 178, 195

Nernst equation, 11, 17, 256

Neutral chemical exposure, paint systems for, 252

Nickel

- anodic polarization, 21
- corrosion resistance, 125
- effect of sulfur content on corrosion protection by, 268
- passive film on, 29
- in weathering steels, 105

Nickel alloys, 35

- decarburization in, 65
- SCC in, 47

Nickel-chromium coating, corrosion of steel at breaks in, 272

Nickel coatings, 267

- bright nickel deposits, 267
- dull bright nickel deposits, 267
- exposure and minimum coating thickness, 270
- nickel-iron alloy coating, 271
- satin finish, 271
- semibright nickel deposits, 267
- sulfur content, 267

Nickel-iron alloy coating, 271

Niobium, 34

Nitrates, as inhibitor in antifreeze solutions, 314

Nitric acid

- iron in, 21
- passive film formation, 28
- and polymer degradation, 168
- production by MIC, 54

Nitrile rubber, 195

Nitrogen compounds, as atmospheric corrodents, 99–100

Nitrous oxide, 78, 83–84

- Noble gases, 166
- Noble metals 264, 267
- anodic control protection by, 267–276
 - chromium coatings, 271–273
 - copper coatings, 264–265
 - EMF control protection by, 264
 - gold coatings, 266
 - lead coatings, 276
 - mechanism of control protection, 264, 267
 - nickel coatings, 267–271
 - tin coatings, 273–276
- Nonmetallic materials, 166
- atmospheric corrosion, 126–154
 - ceramics, 141–145
 - elastomers, 133–134
 - masonry materials, 134–141
 - plastics, 126–132
 - susceptibility to corrosion, 4
- Nuclear power generation, MIC and, 53
- O**
- Offshore structures, corrosion control technology, 377
- Oil and gas plants, MIC in, 53
- Oil-based coatings, 241
- Oily soils, removal, 222
- Oleoresinous primers, 179, 198
- Operating pressure, 332
- Operating temperature, 332
- and liner selection, 185
 - for vessel linings, 180
- Organic coatings
- anodic undermining under, 217
 - blistering under, 215
 - cathodic delamination under, 216–217
 - early rusting in, 218
 - filiform corrosion under, 217
 - flash rusting under, 218
 - in marine industry, 374
 - osmosis under, 215
 - permeability, 214
 - service life, 296
 - solvents affecting, 238
 - types of corrosion under, 213–214
 - wet adhesion under, 214–215
- Organic films
- diffusion of water through, 199
 - glass transition temperatures, 211
- Organic inhibitors, 315–317
- in alkaline solutions, 323
 - concentration and corrosion rate, 316
 - as contact inhibitors, 324
 - corrosion stimulation due to, 318
 - in near-neutral aqueous solutions, 322
 - for near-neutral solutions, 322
- Organic solvents, 202, 226
- Organotrophs, energy source, 51
- Original barrier action, 277
- coating layer, 264
- OSHA regulations, 198, 229
- Osmosis, 214
- under organic coatings, 215
- Overdesign, 3
- Overprotection, in impressed current systems, 305
- Overvoltage, 16
- Oxidation, of polymers, 157
- Oxidation-reduction potentials, 8
- Oxide coatings, 294–295
- Oxide film theory, 28, 90
- Oxidizing inhibitors, 322
- Oxygen, 96
- as atmospheric corrodent, 101
 - as corrosive agent, 364–365
 - flux through representative free films of paint, 199
 - in surface electrolyte, 83
- Oxygen addition, 67
- Oxygen availability, 10
- to microorganisms, 52
- Oxygen concentration cells, 11, 53
- Oxygen reduction, in acids, 6
- Oxygen reduction-neutral solutions, 6
- Oxygen removal, in water treatment and supply systems, 364–365
- Oxygen starvation, 37
- P**
- Paint additives, 204–206
- Paint composition, 200
- additives, 204–206
 - binder, 200–201
 - fillers/extenders, 206

- pigments, 201–202
- solvents, 202–204
- Paint corrosion, 197–198
 - causes of bond and coating failures, 206–213
 - and coating application, 229–241
 - mechanisms of protection, 198–200
 - under organic coatings, 213–218
 - and paint composition, 200–206
 - and paint system selection, 242
 - role of maintenance, 241
 - stages of, 218–220
 - surface preparation to avoid, 220–229
- Paint films, tensile properties, 210, 211
- Paint system selection, 242
 - acidic chemical exposure, 251–252
 - extreme pH exposure, 252–253
 - freshwater exposure, 250
 - freshwater immersion, 251
 - mild exposure areas, 247
 - mild solvent exposure, 252
 - neutral chemical exposure, 252
 - normally dry exteriors, 248
 - saltwater exposure, 251
 - saltwater immersion, 251
 - temporary protection/dry interiors, 248
- Painting systems, 198. *See also*
 - Multilayer coatings
- Paints, 197
 - on aluminum alloys, 121
 - flux of oxygen through
 - representative free films, 199
 - in water treatment and supply systems, 365–366
 - on wood, 151
 - zinc molybdate as inhibiting pigment for, 315
- Partially fluorinated polymers, 167
- Particle board, 150
- Particulate matter, removal from control rooms, 339
- Passivating pigments, 200
- Passivation, 142, 310
 - mechanism, 311–315
- Passivation inhibitors, 311–315
- Passivator concentration, 313
- Passive behavior, 21
 - corrodent velocity and, 24
- Passive film, 28
 - on aluminum, 30
 - on austenitic stainless steel, 29
 - on copper, 29
 - on iron, 28
 - on nickel, 29
 - on tantalum, 30
 - on titanium, 30
- Passive zone, 14
- Patina, 112
 - on copper, 29
 - formation, 114
 - passive film formation, 28
 - on steels, 341
- Peeling failures, 207
- Perfluoroelastomers, 195
- Perfluoropolymers, 166
- Periodic table, and polymer corrosion, 166
- Permeation
 - factors affecting, 162
 - by gases into PFA, 161
 - and polymer degradation, 159–163
 - reducing with fillers, 206
 - relative gas, into fluoropolymers, 162
 - in sheet linings, 188–190, 192–193
 - by vapor into FEP, 161
 - by vapor into PTFE, 160
- Permeation coefficient, 214
- Petroleum refining industry, 358–359
 - adjustments in process conditions, 362
 - corrosion inhibitors, 362
 - crude oil pretreatment, 361
 - crude selection and corrosivity, 361
 - materials selection, 359–361
 - removal of sulfur and impurities, 362–363
- pH adjustment, in water treatment and supply systems, 363–364
- Phase change, in baking cures, 239
- Phase layers, 81
 - dew and, 81
 - dust and, 82
 - fog and, 82
 - and metals corrosion, 92–94
 - rain and, 81–82
- Phenol etch, for plastic substrates, 228
- Phosphate coatings, 291–292

- Phosphates, 369
 - for corrosion control in water distribution systems, 366
- Phosphor bronzes, 116
- Phosphorous, in weathering steels, 105
- Photo-irradiation, 146
- Photochemical degradation, 158, 209
- Photochemical fog, 230
- Phototrophs, energy source, 51
- Physical adsorption, in acid solution, 319
- Physical corrosion, in thermoset polymers, 167
- Physical properties, in materials of construction, 333
- Pickling, 221
- Pigments, 201–202
 - for metal protective paints, 203
- Pinholing, 204, 207
 - and pitting corrosion, 179
 - and premature failure, 181
- Pipe wall linings, 367
- Pipeline industry, 372
 - cathodic protection in, 373
 - coatings used, 372–373
 - internal corrosion issues, 374
- Piping systems, design considerations, 354–355
- Pit formation, 42
- Pitting corrosion, 41–43, 77, 219, 324, 375
 - in aluminum alloys, 118
 - in ceramics, 143
 - by chloride, in austenitic steels, 124
 - in chloride atmospheres, 265
 - due to oxygen on copper, 365
 - effects of inhibitor anions, 325
 - in gas industry, 371
 - maximum pit depth *vs.* exposure time, 118
 - and passivating inhibitors, 314
 - in petroleum refining, 360
 - preventive measures, 43–44
 - in vessel linings, 179
- Pitting resistance equivalent numbers (PREN), 43
- Plastic substrate preparation, 225–226
 - chemical treatment, 227–228
 - detergent cleaning, 226–227
 - mechanical treatments, 227
 - miscellaneous treatments, 229
 - solvent cleaning, 226
- Plastics. *See also* Polymer corrosion
 - atmospheric corrosion in, 126–127
 - non-uniform corrosion rates, 157
 - role of cure, 130
 - thermoplastics, 127–129
 - thermosets, 129–132
- Platinum, stability in atmosphere, 5
- Platinum-clad electrodes, in impressed current systems, 303, 304
- Plywood, corrosion resistance, 149
- Polar solvents, 204
- Polarization, 14–15
 - activation polarization, 15–16
 - concentration polarization, 17–18
 - iron in acid, 15
- Polarization curves, 257
- Polarization measurement, 19, 21
 - anode polarization measurement, 20
 - anodic and cathodic polarization curve, 20
 - anodic polarization, 21–22
- Pollutants, 78, 331, 336
 - and atmospheric corrosion, 87–89
 - deposition of, 93–94
 - in dew, 92
 - in fog, 82
 - indoor and outdoor ranges, 101
- Polyester, 139, 140
- Polyester elastomer, 195
- Polyethylene, 128
- Polymer concrete, corrosion protection, 140
- Polymer corrosion, 157. *See also* Plastics
 - by absorption, 163–166
 - by environmental cracking, 169
 - and lining thickness, 162
 - by permeation, 159–163
 - by radiation, 158–159
 - swelling, 163
 - of thermoplasts, 166–167
 - of thermoset polymers, 167–169
 - by UV degradation, 158–159
- Polymer damage, by UV, 127
- Polymer density, and permeation rate, 189
- Polymer thickness, effects on permeation, 162

- Polymers. *See also* Plastics; Polymer corrosion
 water absorption rates, 164
- Polypropylene, 128
- Polysulfide, 178
- Polyurethane/polyisocyanate foam, as
 insulation material, 346–347
- Polyvinyl chloride (PVC), 128
 design considerations, 339
- Polyvinylidene fluoride (PVDF), 128
- Pores, as starting point of failures, 200
- Porous films, 295
- Portland cement, 134
- Potential difference, 7
- Potential measurements, 306
 impressed current systems, 305, 306
- Potential-pH diagrams, 11–14
 for Fe-H₂O system, 12
- Potential reversal, in tinfoil, 275
- Pourbaix diagrams, 11, 12
 of aluminum alloys, 116
- Powder coating, 233–234
- Power-tool cleaning, 221
- Precipitation inhibitors, 317
- Pressure, and permeation, 188
- Preventive measures, 4. *See also*
 Protective measures
 biological corrosion, 54–55
 corrosion fatigue, 75
 crevice corrosion, 40–41
 erosion corrosion, 45–46
 exfoliation, 74
 filiform corrosion, 77
 hydrogen attack, 67–68
 hydrogen blistering, 65–66
 hydrogen embrittlement, 66–67
 intergranular corrosion, 38
 liquid metal embrittlement, 72
 pitting corrosion, 43–44
 selective leaching, 57
 stress corrosion cracking, 49–50
- Primers, 200
- Process conditions, in petroleum
 refining industry, 362
- Product losses, 3
- Product purity, fluoropolymer coatings
 for, 180
- Protective film, 28
 corrosion inhibition and, 309
- Protective measures. *See also* Preventive
 measures
 aluminum alloys, 120–121
 paint corrosion, 198–200
 uniform corrosion, 31–32
- Psychotrophs, 52
- Psychrophiles, 52
- PVC plastisols, 178, 180
- R**
- Radiation, and polymer corrosion, 157,
 158–159
- Radiation curing, 240
- Rain
 and atmospheric corrosion, 81–82
 and wet atmospheric corrosion,
 92–93
- Rare earth series, 166
- Rate of corrosion, 6, 31
 for copper, by atmospheric type, 113
 stabilization, 104
 uniform corrosion, 30–31
- Recirculating-cooling systems,
 chromatic inhibitors in, 313
- Reconstituted wood products, corrosion
 resistance, 150
- Red-fuming nitric acid, 35
- Red oxide, 294
- Red-water problems, 367
- Redox reactions, 8
- Reduction reactions, 6, 321
 in cathodic protection, 298
 with passivation inhibitors, 311
- Reflowing method, curing by, 240
- Reinforced thermosetting plastic (RTP),
 184
- Relative humidity, 204, 207, 208, 336
 bond strength, exposure time, and,
 208
 and filiform corrosion, 217
 and zinc corrosion, 284
- Reliability requirements, materials of
 construction, 334
- Repair costs, materials of construction,
 334
- Resin, 200–201
 classification of painting systems by,
 198

- organic, 238
 - Resistance. *See* Corrosion resistance
 - Resistance control, 263
 - Resistance control protection, 255, 262, 263
 - Resistance inhibition, 200
 - Reversible absorption, 95
 - Roof insulation, 355
 - Rotational molding, 233
 - Rubber latex, 178
 - Rubbers, 194
 - Rural atmospheres, 78, 329, 330
 - ammonia content in, 111
 - carbon steel corrosion in, 341
 - carbon steel in, 102
 - copper corrosion rates in, 113, 265
 - effects on zinc coating, 285
 - galvanized steel in, 109
 - steel corrosion in, 106
 - Rusting, 207, 218, 219
 - early, 218
 - flash, 218
 - of steel, 340
- S**
- Sacrificial anodes, 44, 298, 299, 300, 370
 - aluminum-based, 300
 - anode requirements, 300–302
 - inert, 303
 - life expectancy, 301
 - magnesium-based, 300
 - zinc-based, 300
 - Sacrificial coatings, tinplate, 275
 - Sacrificial metal coatings
 - average corrosion losses, 280
 - bright nickel deposits, 268
 - cathodic control by, 277–280
 - control protection mechanism, 281
 - corrosion potentials in NaCl solution, 279
 - corrosion products formed on, 278
 - galvanic action, 278, 279
 - service life, 279
 - zinc coatings, 281–283
 - Safety, 1
 - Sag resistance, 206
 - Salt concentration cell, 9
 - Saltwater exchangers, protection issues, 375
 - Saltwater exposure, paint systems for, 251
 - Saltwater immersion, paint systems for, 251
 - Sanding, grit size, 227
 - Satin finish nickel coating, 71
 - Satinizing process, 228
 - Scale, 28
 - Scheduled maintenance, 241
 - Scrap iron
 - in impressed current systems, 304
 - as sacrificial anode material, 303
 - Season cracking, 46
 - in high-zinc brasses, 115
 - Seawater, galvanic series in, 37
 - Secondary barrier action, 277
 - corrosion products, 264
 - noble metal coatings, 267
 - Selective leaching, 55–57, 325
 - alloy and environment combinations, 56
 - in ceramics, 144
 - preventive measures, 57
 - Semibright nickel deposits, 267, 268
 - Semitransparent penetrating stains, 153
 - Sensitization, 32
 - prevention with stabilized stainless steels, 34
 - and welding temperature, 33
 - Service life
 - and choice of sacrificial metal, 280
 - organic coatings, 296
 - sacrificial anodes, 301
 - sacrificial metal coatings, 279
 - Shatter cracks, 63
 - Sheet linings, 183–184
 - absorption considerations, 190–191, 193
 - bonded, 186–187
 - causes of failure, 192–194
 - debonding, 193
 - design considerations, 188–191
 - environmental stress cracking, 193–194
 - fluoropolymer-based, 187
 - inadequate surface preparation, 192
 - inspection, 191–192

- liner selection, 185–187, 192
- operation considerations, 193
- permeation considerations, 188–190, 192–193
- shell design, 184–185
- thermal stresses, 192
- unbonded, 187
- welding flaws in, 193
- Shell design, for sheet linings, 184–185
- Sheltering
 - and atmospheric corrosion, 85–86
 - avoiding in equipment design, 337, 342
- Sherardizing, 282
- Shot peening, 49, 75
- Shutdown, 2
- Sideways diversion, 268
- Silica sand, banning of, 222
- Silver-lead electrodes
 - in impressed current systems, 304
 - use in impressed current systems, 303
- Sodium chromate, 313
- Sodium hydroxide etch, for plastic substrates, 228
- Sodium hypochlorite etch, for plastic substrates, 228
- Sodium nitrite, as inhibitor in antifreeze solutions, 314
- Sodium silicate inhibitors, 370
 - in insulation systems, 343
- Softwood
 - atmospheric resistance, 147–148
 - painting and weathering characteristics, 152
- Soil resistivity, in impressed current systems, 304
- Solar maximum condition, 209
- Solid color stains, for wood, 153
- Solubility, and permeability in polymers, 160
- Solvation, in polymers, 157
- Solvent cleaning, 221
 - metal substrates, 223
 - plastic substrates, 226
- Solvent evaporation, 239
- Solvent resistance, 169
- Solvents, 202–204
 - affecting organic resins, 238
 - classes and characteristics, 205
 - organic, 204
 - paint systems for exposure to mild, 252
- Special environments, design considerations, 354
- Spray painting, 232–233
- Stainless steels
 - alloy content and sensitivity to SCC, 48
 - austenitic grades, 123–124
 - control of inclusions in, 65
 - corrosion resistance, 122–123
 - crevice corrosion, 39
 - duplex grades, 125
 - as enclosure materials, 339
 - ferritic grades, 124
 - martensitic grades, 124–125
 - passivity of, 36
 - pitting in, 42
 - resistance to erosion corrosion, 45
 - SCC in, 47
 - and stability of carbides, 64
 - stabilized, 34
- Standard single potentials, 258
 - metal/metal ion equilibria at anode, 256
 - noble metals, 264
- Standing water, 55
- Stationary period, 85
- Steam cleaning, metal substrates, 223
- Steam cycle test, 165
- Steel
 - atmospheric corrosion by
 - atmospheric type, 106
 - cathodic delamination, 217
 - corrosion at breaks in nickel-chromium coating, 272
 - corrosion due to inorganic zinc coatings, 353
 - duplex nickel electrode deposit, 272
 - effect of chromate concentration, chlorides, and temperature on corrosion, 315
 - safe operating limits in hydrogen, 64
 - surface pretreatment, 224
 - Steel structures
 - multistage paint coating systems, 237
 - paint systems for, 235, 236

- Steel Structures Paining Council (SSPC), 221
 - Storage facilities, cathodic protection in, 297
 - Strain rate, and LME, 71
 - Stray currents, mitigation of, 372
 - Stress considerations, materials of construction, 333
 - Stress corrosion cracking (SCC), 24, 41, 46–49, 61, 77
 - alloy-environment combinations causing, 47
 - brass resistance to, 115
 - cupronickel resistance to, 116
 - inhibition with austenitic stainless steels, 325
 - in polymers, 169
 - preventive measures, 49–50
 - Stress failures, 213
 - Stress raisers, 49
 - Structural failure, due to pitting, 41
 - Structure supports, cathodic protection in, 297
 - Styrene-butadiene polymers, 178
 - Sulfur compounds, 98, 140
 - as atmospheric corrodents, 97–99
 - in chromium coatings, 271
 - and corrosion rate of zinc coatings, 283, 284
 - effect on corrosion protection of nickel, 268
 - effects on concrete, 136
 - industrial contamination by, 78
 - in nickel coatings, 267
 - in petroleum refining industry, 359
 - removal in petroleum refining industry, 362–363
 - Sulfur dioxide, 83, 110, 121, 330
 - and uniform corrosion of copper coatings, 265
 - Sulfuric acid, 97, 295
 - in petroleum refining industry, 360
 - and polymer degradation, 168
 - Sulfuric acid-dichromate etch bath, 228
 - Sulfuric acid etch, for plastic substrates, 227–228
 - Sunde equation, 302
 - Surface cleanliness, 24
 - Surface electrolyte composition, 83
 - carbon dioxide, 84
 - chlorides, 84
 - nitrous oxide, 83–84
 - oxygen, 83
 - species concentration, 84
 - sulfur dioxide, 83
 - Surface energy, 225
 - Surface finish, 24
 - Surface orientation, metal surfaces, 93
 - Surface preparation, 220
 - avoiding coating failures with, 207
 - metal substrate preparation, 197, 220–223
 - metal surface pretreatment, 223–225
 - multilayer paint systems requiring commercial blast for, 243–245
 - plastic substrate preparation, 225–229
 - for sheet linings, 192
 - summary of specifications, 221
 - Surfactants, 206
 - Synthetic materials, atmospheric corrosion, 77
- T**
- Tafel coefficients, 260
 - Tafel equation, 16
 - Talc, as extender, 206
 - Tank design, design considerations, 355
 - Tank linings, 171. *See also* Lining corrosion
 - Tantalum, passive film on, 30
 - Temperate environments, 329
 - Temperature
 - allowable ranges for thermoplastics, 130
 - effect on atmospheric corrosion rates, 84–85
 - effects on permeation, 162
 - fluctuations and corrosion, 154
 - and LME, 71
 - and microbial growth, 52
 - operating ranges
 - elastomers, 136
 - thermoset polymers, 132
 - and permeation, 188
 - and selecting materials of construction, 332–333

- Temperature range, and biological corrosion, 52
 - Tensile strength, 210
 - loss of, 58
 - Tensile stress, 46
 - Termite attack, 148
 - Terneplate, 276
 - Thermal degradation, of polymers, 157
 - Thermal insulation system, selection table, 343
 - Thermal stresses, 49
 - in sheet linings, 192
 - Thermally applied coatings, zinc, 283
 - Thermally sprayed coatings, 287
 - Thermophiles, 52
 - Thermoplastic resins, 238
 - ease of repair, 241
 - Thermoplastics, 126
 - abbreviations, 129
 - allowable temperature ranges, 130
 - atmospheric corrosion, 127–129
 - atmospheric resistance, 131
 - corrosion of, 166–167
 - Thermosets, 126
 - atmospheric corrosion in, 129–132
 - atmospheric resistance, 132
 - corrosion mechanisms, 167–169
 - operating temperature ranges, 132
 - Thermosetting resins, 238, 241
 - Thiourea, as organic inhibitors, 315
 - Threshold stress, 46
 - Throwing power, 235
 - Time, and corrosion severity, 24
 - Time of wetness, 80, 279
 - adsorption layers and, 80–81
 - and atmospheric corrosion of zinc, 110
 - and copper coating corrosion rate, 265
 - measurement, 82–83
 - phase layers and, 81–83
 - Tin bronzes, 116
 - Tin coatings, 273–276
 - noble and sacrificial, 275
 - as sacrificial anode for steel, 274
 - Tinplate, 273–276
 - contents and pH range, 274
 - potential reversal in, 275
 - Titanium
 - anodic polarization, 21
 - as desensitizing agent, 34
 - passive film on, 30
 - pitting resistance, 44
 - and SCC, 48
 - surface pretreatment, 224
 - Titanium alloys, SCC in, 47
 - Titanium precipitation, 34
 - Topcoats, 200
 - Total dissolved solids (TDS), 363
 - Toughness, in materials of construction, 333
 - Toxic Substances Control Act (TSCA), 229
 - Transition metals, 166
 - Transition period, 85
 - Transparent coatings, for wood, 153
 - Trinickel, 268, 269
 - Tropical environments, 329
 - Troposphere, 96
 - Turbulence, 44
- U**
- Ultraviolet (UV) light, 126, 208
 - polymer damage from, 127, 211
 - and polymer degradation, 158, 159
 - wavelength regions, 127, 209
 - Unbonded linings, 187
 - Underbead cracking, 58
 - Underfilm corrosion, 183
 - Underground metallic members, 297
 - Underground pipelines, 297, 300, 301
 - bare metal vs. coated, 307
 - in gas industry, 372
 - MIC in, 53
 - types of corrosion in, 371–372
 - Uniform corrosion, 27–28
 - in ceramics, 143
 - copper coatings, sulfur dioxide atmospheres, 265
 - passive film on aluminum, 30
 - passive film on austenitic stainless steel, 29
 - passive film on copper, 29
 - passive film on iron, 28
 - passive film on nickel, 29
 - passive film on tantalum, 30
 - passive film on titanium, 30

- rates, 30–31
 - Urban atmospheres, 329, 330
 - and aluminum alloys, 117
 - carbon steel corrosion in, 341
 - copper corrosion rates in, 113
 - maximum pit depth *vs.* exposure time, 118
 - steel corrosion in, 106
 - Urethane, 139, 178
 - Urethane foam, 345
 - Urethane rubber, 195
- V**
- Valence states, 6, 28
 - Valve specifications, in piping systems, 354
 - Vapor barriers, 344
 - Vapor curing, 240
 - Vapor degreasing, metal substrates, 223
 - Vapor permeation
 - into FEP, 161
 - into PTFE, 160
 - Vapor-phase inhibitors, 317–318
 - in chemical industries, 357
 - Varnishes, 197
 - Verdigras, 112
 - Vessel design, for liquid applied linings, 172–176
 - Vinyl ester, 139, 140, 167, 169, 178, 337
 - Vinyl paints, 206
 - Vinyl urethanes, 178
 - Vinylidene chloride latex, 179
 - Visible light, 126
 - Volatile organic compound (VOC) restrictions, 198, 235
- W**
- Water
 - as atmospheric corrodent, 79
 - diffusion through organic films, 198, 199
 - dissociative absorption, 95
 - reversible absorption, 95
 - Water absorption rates
 - polymers, 163, 164
 - in sheet lining materials, 190
 - Water monolayers, 91
 - Water quality modifications, 363
 - Water repellents, for wood, 153
 - Water storage tanks, linings and coatings, 368
 - Water tanks
 - cathodic protection in, 298
 - coatings with cathodic protection in, 307
 - Water treatment and supply systems
 - cathodic protection for, 370
 - design considerations, 363
 - design features, 370–371
 - inhibitors for, 366–368
 - linings, coatings, and paints, 365–366
 - materials corrosion properties, 369
 - materials selection, 366
 - MIC in, 53
 - oxygen removal, 364–365
 - pH adjustment, 363–364
 - pipe wall linings, 367
 - system design, 366
 - water quality modifications, 363
 - water storage tank linings and coatings, 368
 - Weathering
 - ability to withstand, 209
 - in polymers, 159
 - Weathering steels, 86, 340, 341
 - corrosion resistance, 104–106
 - Weight expressions, 25
 - Weld decay, 33
 - Weld failures, 207
 - Weld spatter, 184
 - removal, 173
 - Welding flaws, in sheet linings, 193
 - Welding temperature, 33
 - Wet adhesion, under organic coatings, 214–215
 - Wet atmospheric corrosion
 - dew and, 92
 - fog and, 93
 - of metals, 92
 - rain and, 92–93
 - Wet deposition, 93
 - sulfur compounds, 98
 - White-metal blast cleaning, 221
 - White rust, 108, 109
 - Wind velocity, and atmospheric corrosion, 86

Wood

- applied exterior wood finishes,
 - 151–153
 - corrosion resistance, 145–149
 - paints, 151
 - plywood, 149
 - reconstituted wood products, 150
 - semitransparent penetrating stains,
 - 153
 - solid color stains, 153
 - transparent coatings for, 153
 - water-repellent preservatives, 151
 - water repellents, 153
- Wood-boring beetle, 148

Z

Zinc

- in brasses, 115
 - corrosion products formed on, 107
 - corrosion resistance, 106–109
 - in galvanized steel, 109
 - in impressed current systems, 305
 - inorganic, as lining, 179, 250
 - role in protecting copper against corrosion, 297
 - as sacrificial anode, 370, 375
 - surface pretreatment, 225
- Zinc-5% aluminum hot dip coatings,
 - 285–286
- Zinc-55% aluminum hot dip coatings,
 - 286–287
- Zinc-15% aluminum thermal spray,
 - 287–288
- Zinc alloy coatings, corrosion resistance on steel, 109–111
- Zinc alloys, as sacrificial anodes, 298

- Zinc-aluminum hot dip coatings,
 - corrosion resistance, 111
- Zinc-aluminum thermally sprayed coatings, corrosion resistance,
 - 111–112
- Zinc carbonate, 108
- Zinc coatings
 - coating thickness, 281
 - corrosion of, 283–285
 - corrosion resistance on steel, 109–111
 - hot dip galvanizing, 281
 - inorganic, 353
 - mechanical coating, 282
 - sacrificial, 281–283
 - sherardizing, 282
 - thermally sprayed coatings, 283
 - zinc-5% aluminum hot dip coatings,
 - 285–286
 - zinc-55% aluminum hot dip coatings,
 - 286–287
 - zinc-15% aluminum thermal spray,
 - 287–288
 - zinc dust painting, 283
 - zinc electroplating, 282
 - zinc-iron alloy coatings, 288–289
- Zinc dust painting, 283
- Zinc electroplating, 282
- Zinc hydroxide, 107
- Zinc-iron alloy coatings, 288–289
 - corrosion resistance, 112
- Zinc molybdate, as inhibiting pigment for paints, 315
- Zinc oxide, protective actions, 204, 206
- Zinc-rich coatings, 241
 - primers, in chemical industries, 358
- Zinc sulfate, 107

Materials Science

Fundamentals of CORROSION

Mechanisms, Causes,
and Preventative Methods

Philip A. Schweitzer

Billions of dollars are spent annually for the replacement of corroded structures, machinery, and components. Premature failure of bridges or structures due to corrosion can also result in human injury, loss of life, and collateral damage.

Written by an authority in corrosion science, *Fundamentals of Corrosion: Mechanisms, Causes, and Preventative Measures* comprehensively describes the causes of corrosion — and the means to limit or prevent it. Engineers, designers, architects, and all those involved with the selection of construction materials will relish a reference that provides such a thorough yet basic illustration of the causes, prevention, and control of corrosion.

This reference explores:

- Mechanisms and forms of corrosion
- Methods of attack on plastic materials
- Causes of failure in protective coatings, linings, and paints
- Development of new alloys with corrosion-resistant properties

Exposure to the atmosphere is one of the largest problems and biggest causes of corrosion that engineers and designers face in construction. It has been further estimated that the cost of protection against atmospheric corrosion accounts for approximately half the total cost of all corrosion protection methods. This book places special emphasis on the topic and presents vital information regarding the design of structures, automobiles, household plumbing, manufacturing equipment, and other entities, as well as the effects of de-icing chemicals on highways and bridges.

 **CRC Press**
Taylor & Francis Group
an informa business
www.crcpress.com

6000 Broken Sound Parkway, NW
Suite 300, Boca Raton, FL 33487
270 Madison Avenue
New York, NY 10016
2 Park Square, Milton Park
Abingdon, Oxon OX14 4RN, UK

67702
ISBN: 978-1-4200-6770-5
90000

9 781420 067705