

Thermal Therapy, Part 2: Hyperthermia Techniques

Riadh W. Y. Habash,^{1} Rajeev Bansal,² Daniel Krewski,³ and Hafid T. Alhafid⁴*

¹McLaughlin Centre for Population Health Risk Assessment, Institute of Population Health/School of Information Technology and Engineering, University of Ottawa, Ottawa, Ontario, Canada; ²Department of Electrical and Computer Engineering, University of Connecticut, Connecticut, USA; ³McLaughlin Centre for Population Health Risk Assessment, Institute of Population Health, University of Ottawa, Ottawa, Ontario, Canada; ⁴College of Engineering and Applied Sciences, Al Ghurair University, Dubai, UAE

Address all correspondence to Riadh W. Y. Habash, McLaughlin Centre for Population Health Risk Assessment, Institute of Population Health, University of Ottawa, One Stewart Street, Room 320, Ottawa, Ontario, Canada K1N 6N5; rhabash@site.uottawa.ca

ABSTRACT: Hyperthermia, the procedure of raising the temperature of a part of or the whole body above normal for a defined period of time, is applied alone or as an adjunctive with various established cancer treatment modalities such as radiotherapy and chemotherapy. Clinical hyperthermia falls into three broad categories, namely, (1) localized hyperthermia, (2) regional hyperthermia, and (3) whole-body hyperthermia (WBH). Because of the various problems associated with each type of treatment, different heating techniques have evolved. In this article, background information on the biological rationale and current status of technologies concerning heating equipment for the application of hyperthermia to human cancer treatment are provided. The results of combinations of other modalities such as radiotherapy or chemotherapy with hyperthermia as a new treatment strategy are summarized. The article concludes with a discussion of challenges and opportunities for the future.

KEYWORDS: heating devices, radiotherapy, chemotherapy, radiochemotherapy

I. INTRODUCTION

The term hyperthermia broadly refers to either an abnormally high fever or the treatment of a disease by the induction of fever, as by the injection of a foreign protein or the application of heat.¹ Hyperthermia as a method of treating cancer has a long history. Many Greek and Roman physicians thought that if they could simply control body temperature they could cure all diseases. This included cancer, with the pathology of tumor development having been described in the Greek literature.²

Hyperthermia may be defined more precisely as raising the temperature of a part of or the whole body above normal for a defined period of time. The extent of temperature elevation associated with hyperthermia is on the order of a few degrees above normal temperature (41–45°C). The effect of hyperthermia depends on the temperature and exposure time. First, there is the curative, physiologically based therapy (physiological hyperthermia), which treats aches, pains, strains, and sprains. This is applied in the following multiple sessions: use low temperature (e.g., below 41°C) for approximately an hour; have a reparative goal of accelerated tissue healing; and use physiological mechanisms of increasing blood flow and metabolic rates.³ At temperatures above 42.5–43°C, the exposure time can be halved with each 1°C temperature increase to give an equivalent cell kill.⁴ Most normal tissues are undamaged by treatment for 1 hr at a temperature of up to 44°C.⁵ The main mechanism for cell death is probably protein denaturation, observed at temperatures > 40°C, which leads to, among other things, alterations in multimolecular structures such as cytoskeleton and membranes, and changes in enzyme complexes for DNA synthesis and repair.⁶

The first paper on hyperthermia was published in 1886.⁷ According to the author, the sarcoma that occurred on the face of a 43-year-old woman was cured when fever was caused by erysipelas. Westermarck⁸ used circulating high-temperature water for the treatment of an inoperable cancer of uterine cervix with beneficial results. In the early twentieth century, both applied and basic research on hyperthermia was carried out; however, the heating methods and temperature-measuring technologies were not sufficiently advanced at that time and positive clinical application of hyperthermia treatment was not accomplished. Consequently, surgeries, radiotherapy, and chemotherapy remained the dominant therapies for tumors.⁹ Worldwide interest in hyperthermia was initiated by the first international congress on hyperthermic oncology in Washington in 1975. In the United States, a hyperthermia group was formed in 1981 and the European Hyperthermia Institute was formed in 1983. In Japan, hyperthermia research started in 1978 and the Japanese Society of Hyperthermia Oncology was established in 1984.

This developing interest has followed a course that is usual for a new type of treatment. In the first decade there was a growing enthusiasm, reflected by an exponential increase in the number of papers and participants at meetings. Thereaf-

ter, the interest waned, due to disappointing clinical results from some of the first randomized studies, accompanied by reluctance among sponsoring authorities and hospital boards to support further research. Today, there appears to be a renewed interest, thanks to several investigations demonstrating that the improvements in treatment outcome by adjuvant hyperthermia can be very substantial, provided that adequate heating procedures are used.¹⁰

In recent decades, extensive studies have been performed in the field of hyperthermia, ranging from the mechanisms of thermal cell kill to clinical trials and treatments. A series of books have been published summarizing the many experimental and clinical studies in the field of hyperthermia.¹¹⁻¹⁴ Other books describing hyperthermia and its clinical applications have been authored or edited.^{9,15-20} Several book chapters also focused on hyperthermia.²¹⁻²⁵ There is an increasing number of relevant published periodicals as well as a large number of scientific articles published in high-ranked journals that review the physical background and technical realization of hyperthermia.^{3,26-49} A large body of scientific and clinical literature demonstrating the effectiveness of hyperthermia, either alone or combined with radiotherapy or chemotherapy, has been published during the past few years.^{6,10,23,41,50-68} The increasing number of applications and clinical trials at universities, clinics, hospitals, and institutes proves the feasibility and applicability of clinical hyperthermia in cancer therapies.⁴⁹

The objective of this review is to outline and discuss the means by which electromagnetic (EM) energy and other techniques can provide temperature elevation within the human body. Clinical hyperthermia falls under three major categories, namely, localized, regional, and whole-body hyperthermia (WBH). Because of the individual characteristics of each type of treatment, different types of heating systems have evolved. Hyperthermia may be applied alone or jointly with other modalities such as radiotherapy, chemotherapy, surgical treatment, and immunotherapy. The article concludes with a discussion of the challenges and opportunities for medical applications of hyperthermia in the future.

II. BIOLOGICAL RATIONALE

The clinical exploitation of hyperthermia was and still is hampered by technical limitations and the high degree of interdependency between technology, physiology, and biology.^{69,70} Extensive biologic research has shown that there are sound biological reasons for using hyperthermia in the treatment of malignant diseases.³⁵ The biological rationale for the treatment of malignant disease by heat is mediated by a number of reasons. First, the survival of cells depends on the temperature and duration of heating in a predictable and repeatable way. For example, when the temperature increases, the survival rate of the cell becomes lower. Second, tumor cell environment, such as hypoxia, poor nutrition, and low pH, while detrimental to cell kill by ionizing radiation, is beneficial to heat therapy. Third, cells may develop a resistance to subsequent heat following previous heat

treatment. This condition is known as thermotolerance. Fourth, the differential sensitivity of normal and tumor cells to heat is dependent on cell type and environmental conditions. And finally, heat treatment enhances the biological effect of both radiation and chemotherapy agents.^{9,34}

A. Heat Alone

The biological rationale is based on a direct cell-killing effect at temperatures above 41–42°C.⁶ However, the thermal-dose-response relation varies among cell lines and depends on microenvironmental factors such as pH.⁷¹ Protein damage is the main molecular event underlying the biological effects of hyperthermia in the clinically relevant temperature range (39–45°C). The activation energies for protein denaturation and heat-induced cell death are within the same range.⁶ Cellular and tissue level studies, both *in vitro* and *in vivo*, indicate that protein denaturation is the most likely thermal effect causing permanent irreversible damage.⁷² Biophysical approaches^{73–75} as well as work with model proteins^{76,77} have directly shown that substantial protein denaturation occurs in the clinically relevant temperature range. As a result of denaturation, proteins are prone to aggregation. Without chaperones, these aggregates can have destructive consequences for many macromolecular structures and their functions.⁶⁶

The responses of tumors to hyperthermia involve both cellular and host-related factors. Frequently, it is not easy to separate these experimentally. When cells are exposed to elevated temperatures, they are inactivated in a time- and temperature-dependent fashion. Inactivation starts at about 40 to 41°C, at least, for murine cells and tumors. At these low temperatures, cell inactivation continues for only a few hours; beyond that time, the surviving cells appear resistant to further exposure to such temperatures. Studies have shown that this is not a selection of heat-resistant subpopulations, but rather a consequence of the induction of a temporary resistance to heat. This transient phenomenon is referred to as thermotolerance. However, very prolonged heating at mild temperatures (41–42°C) overcomes this transient thermotolerance.⁷⁸ Above 43°C, for most rodent lines, inactivation is exponential with time and thus resembles cell inactivation by ionizing radiation. Human cells tend to be more resistant, and in some human tumor cell lines this temperature threshold is as high as 44.5°C. Hence, thermotolerance can develop during treatment of human lesions, since tumor temperatures only rarely exceed 44°C. At even higher temperatures, thermotolerance does not develop; however, if the cells are returned to 37°C, the surviving cells become resistant within a few hours. At temperatures between 41°C and 42°C, human tumor cell lines may be more sensitive than rodent tumor cells, and a potential therapeutic advantage may be achieved with prolonged heating at these milder temperatures.⁷⁹

The development of thermotolerance is accompanied by the preferential synthesis (or *de novo* synthesis) of a series of proteins referred to as heat-shock pro-

teins (HSPs). These molecules are the subject of intense study because of their importance in normal cell function and in various disease states.⁸⁰ Thermotolerance can also greatly modify the cellular response to some drugs or heat in combination with X-irradiation, but it does not seem to have much effect on the cells' response to X-irradiation alone.⁸¹

In addition to thermotolerance, there is great variability in genetically determined heat sensitivity of tumor cells. The frequency of occurrence of such cells appears to be very low; however, there is no evidence of cross-resistance between heat sensitivity and X-irradiation or most anticancer drugs. Hence, genetically heat-resistant cells may be of little importance during combination treatments with heat and radiation or chemotherapy.

B. Heat and Radiation

Aggregation of nuclear proteins damage is thought to be the central event by which heat makes cells more sensitive to radiation.^{74,82} The synergy between heat and radiation, often expressed as thermal enhancement ratios (TERs), is highest when the two modalities are given simultaneously. When heat precedes radiation, the synergy is lost when the time interval between the two modalities increases; this loss of TERs nicely parallels the decline in protein aggregation.⁸³ It is important to note that at the time when the TER is maximal (during or immediately after heating), HSP levels have not yet increased; conversely, when HSP levels are maximal, cells have regained normal radiosensitivity. This means that HSPs are not involved in thermal radiosensitization and, more importantly, that physiological upregulations in HSPs that make cells thermotolerant cells are heated, they do become less well radiosensitized than nonthermotolerance control cells and the decline of radiosensitization is more rapid as if the cells had been heated with a milder heat treatment. This is because in the thermotolerance cells' nuclear protein, aggregation is attenuated and/or repaired more rapidly due to the elevated HSP levels.^{66,83}

Heat enhances the cytotoxicity of X-rays, in a supra-additive fashion. Supra-additivity refers to an increase in cytotoxicity observed over and above what would be expected on the basis of additivity of the two treatments, and it is maximum when these are given simultaneously. It decays with time when the treatments are separated by more than one or two hours (even less in some systems).^{15,35}

C. Heat and Drugs

A lot of physiology-related features make a combination of heat and drugs very attractive. Moreover, heat can cause supra-additive killing when combined with alkylating agents, nitrosureas, platinum drugs, and some antibiotics,⁸⁴ although

for some drugs only additive effects or even less than additive effects on cell death are found.⁶⁶ The most impressive results in this regard are for heat and cisplatin treatments. Synergistic killing is already found at rather mild heat treatments.⁸⁵

When cells are exposed at elevated temperatures to drugs, their response is frequently very different from that seen at 37°C. Drugs whose rate-limiting reaction is primarily chemical (i.e., not involving enzymes) would, on thermodynamic grounds, be expected to be more efficient at higher temperatures. The rates of alkylation of DNA, or of conversion of a nonreactive species to a reactive one, can be expected to increase as the temperature increases. Tissue culture studies have shown this to be true for the nitrosoureas and cisplatin. For other drugs, there appears to be a threshold at or near 43°C. Below that temperature, drug activity is only mildly enhanced. At higher temperatures, however, cell killing proceeds at a greatly enhanced rate. The combination of chemotherapy with hyperthermia still deserves attention and has high potential.⁶⁶

III. TYPES OF HYPERTHERMIA

Hyperthermia is mostly applied within a department of radiation oncology under the authority of a radiation oncologist and a medical physicist. Hyperthermia is always implemented as part of a multimodal, oncological treatment strategy, i.e., in combination with radiotherapy or chemotherapy.⁶⁹ The effectiveness of hyperthermia treatment is related to the temperature achieved during the treatment, as well as the length of treatment and cell and tissue characteristics.^{10,86} To ensure that the desired temperature is reached, but not exceeded, the temperature of the tumor and surrounding tissues is monitored throughout the hyperthermia procedure.^{59,60} The majority of hyperthermia treatments are applied using external devices, employing energy transfer to tissues by EM technologies.^{87,88}

A. Local Hyperthermia

The success of hyperthermia as a treatment modality lies in the localization of the heat inside the cancerous tumor without causing thermal damage to surrounding normal tissues. In local hyperthermia, the aim is to increase mainly the tumor temperature while sparing surrounding normal tissue, using either external or interstitial modalities. Heat is applied to a small area, such as a tumor, using various techniques that can deliver energy to heat the tumor. Local hyperthermia treatment is a well-established cancer treatment method with a simple basic principle, namely, if a rise in temperature to 42°C can be obtained for one hour within a cancer tumor, the cancer cells will be destroyed. Primary malignant tumors have poor blood circulation, which makes them more sensitive to changes in temperature.

Local hyperthermia is performed with superficial applicators (RF, microwave, or ultrasound) of different kinds (waveguide, spiral, current sheet) placed on the surface of superficial tumors with a contacting medium (bolus). The resulting specific absorption rate (SAR) distribution is subject to strong physical curtailment resulting in a therapeutic depth of only a few centimeters and is even further limited in regions with an irregular surface, such as the head and neck area, or the supraclavicular region. The penetration depth depends on the frequency and size of the applicator; the clinical range is typically not more than 3–4 cm. A system for local hyperthermia consisting of a generator, control computer applicator, and a scheme to measure temperature in the tumor is shown in Figure 1. The power is increased until the desired temperature is achieved.

The volume that can be heated depends on the physical characteristics of the energy source and on the type of applicator.⁸⁹ During local hyperthermia, the tumor temperatures are increased to levels that are as high as possible, as long as the tolerance limits of the surrounding normal tissues are not exceeded.¹⁰

Candidates for local hyperthermia include chest wall recurrences, superficial malignant melanoma lesions, and lymph node metastases of head and neck tumors. Development areas in the delivery of local hyperthermia include the development of additional techniques for heating, the expansion of the tumor locations that can be treated adequately, and the improvement of existing systems.^{90–92}

1. External Local Hyperthermia

Heating of small areas (usually up to 50 cm²) to treat tumors in or just below the skin (up to 4 cm) may be achieved quite easily. External local hyperthermia therapy may be used

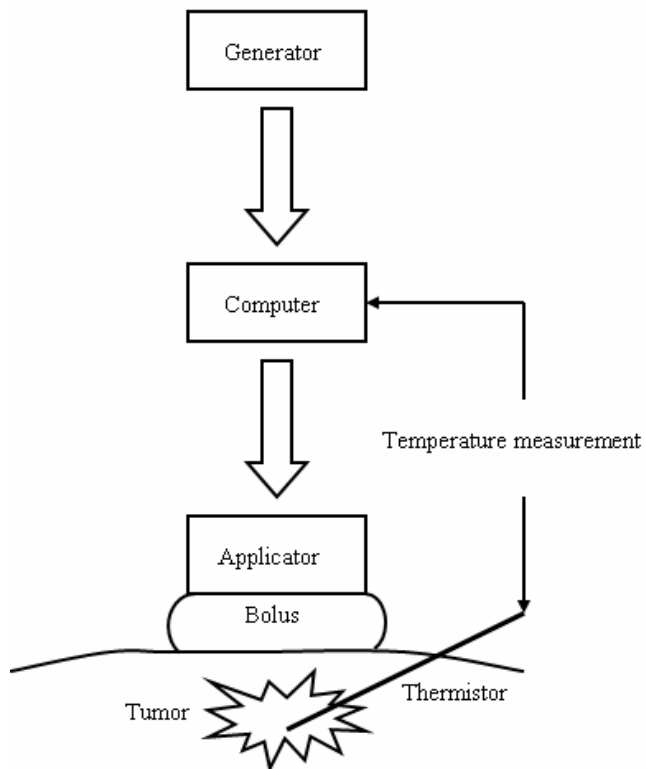

FIGURE 1. A diagram for local hyperthermia.

alone or in combination with radiation therapy for the treatment of patients with primary or metastatic cutaneous or subcutaneous superficial tumors (such as superficial recurrent melanoma, chest wall recurrence of breast cancer, and cervical lymph node metastases from head and neck cancer). Heat is usually applied using high-frequency energy waves generated from a source outside the body (such as a microwave or ultrasound source).

2. Intraluminal Local Hyperthermia

Intraluminal or endocavitary methods may be used to treat tumors within or near body cavities. Endocavitary antennas are inserted in natural openings of hollow organs. These include (1) gastrointestinal (esophagus, rectum), (2) gynecological (vagina, cervix, and uterus), (3) genitourinary (prostate, bladder), and (4) pulmonary (trachea, bronchus).⁵¹ Very localized heating is possible with this technique by inserting an endotracheal electrode into lumens of the human body to deliver energy and heat the area directly. Various types of electrodes are available depending on the size of the lumen and the site of the lesion.

To improve the treatment results of locally advanced oesophageal carcinoma, Sugimachi et al.,⁹³⁻⁹⁵ Kitamura et al.,⁹⁶ and Saeki et al.⁹⁷ used intraluminal RF hyperthermia in addition to external irradiation and chemotherapy to treat inoperable cases and reported good therapeutic results. Fuwa et al.⁹⁸ developed an applicator enabling simultaneous intraluminal radiotherapy and intraluminal hyperthermia delivery to improve the treatment results for locally advanced oesophageal carcinoma. Hyperthermia was delivered by a RF current thermotherapy instrument for 30 min at an output that raised the esophageal mucosal surface temperature to 42–43°C. Intraluminal radiotherapy was delivered to a submucosal depth of 5 mm after the first 15 min of hyperthermia. Four cases out of eight achieved complete response, with all demonstrating local control. Partial response was obtained in four cases, and three of these patients died of local recurrence. There were no significant adverse side effects apart from a fistula in one case. These results represent an improvement over previous work⁹⁹ on treatment by an applicator that simultaneously delivered an intraluminal high dose of iridium irradiation and intraluminal RF hyperthermia.

Recently, Freudenberg et al.¹⁰⁰ measured the effect of hyperthermia applied through a heatable stent in the esophagus in order to investigate whether this procedure offers a therapeutic option for tumor treatment. The maximal heating temperature tolerated in the esophagi without transmural necrosis was 46.5°C, when applied twice for 60 min with a pause of 48 hr. With this procedure, a tumor-damaging temperature of 42.5°C was achieved at a maximum distance of 12 mm surrounding the stent.

3. Interstitial Local Hyperthermia

Interstitial techniques are used to treat tumors deep within the body, such as brain tumors. Many types of interstitial hyperthermia equipment are used. These include local current field techniques utilizing RF energy (at a frequency of 0.5 MHz), microwave techniques utilizing small microwave antennas inserted into hollow tubings with frequencies of 300–2450 MHz, ferromagnetic seed implants for delivering thermal energy to deep seated tumors, hot water tubes, and laser fibers. Interstitial heating allows the tumor to be heated to higher temperatures than external techniques. Other advantages of this technique include better control of heat distributions within the tumor as compared with external hyperthermia, and the sparing of normal tissues, especially the overlaying skin. On the other hand, the disadvantages are invasiveness, difficulty in repeated treatment, and limitation of applicable sites.

Under anesthesia, probes or small needles (thin antennas) are inserted into the body to produce localized deposition of EM energy in subcutaneous and deep-seated tumors. For treatment regions that are large compared to the field penetration depth of the frequency used, the required SAR uniformity throughout a tumor volume cannot be achieved with a single antenna, and arrays of antennas are then employed.^{101,102} Imaging techniques, such as ultrasound, may be used to make sure the probe is properly positioned within the tumor.

B. Regional Hyperthermia

Regional heating is indicated for patients with locally advanced deep-seated tumors such as those in the pelvis or abdomen. The application of regional hyperthermia is, however, more complex than local heating, particularly because of the wide variation in physical and physiological properties of body tissues. It requires more sophisticated planning, thermometry, and quality assurance. Since regional heating techniques apply energy to the adjacent deep-seated tumors in a focused manner, energy is also delivered to the adjacent normal tissues. Under such conditions, selective heating of tumors is only possible when heat dissipation by blood flow in normal tissue is greater than that in tumor tissue. Most clinical trials on regional hyperthermia have used the approach as an adjunct to radiotherapy.⁶⁰ Locally advanced and/or recurrent tumors of the pelvis are the major indications for regional hyperthermia, including rectal carcinoma, cervical carcinoma, bladder carcinoma, prostate carcinoma, or soft tissue sarcoma. Some of these indications were validated in prospective studies.

1. Deep Regional Hyperthermia

Heat delivery to deep-seated tumors is the most difficult problem in applications of hyperthermia, and major efforts have been devoted to the development of ex-

ternal deep-heating equipment. The ideal heating device should be capable of raising the whole tumor volume to a therapeutic temperature without overheating adjacent normal tissues.⁴¹ Treatments of deep-seated tumors are difficult because EM energy is rapidly absorbed by human tissue.¹⁰³ External applicators are positioned around the body cavity or organ to be treated, and EM energy is focused on the area to raise its temperature. Deep regional hyperthermia is usually performed using arrays of multiple applicators.¹⁰⁴ For example, annular phased-array systems delivering EM energy and RF capacitive heating apparatus are examples of regional heating devices. This type of system has the advantage that subcutaneous fat is not excessively heated, and it is therefore suitable for obese patients. However, this method causes systemic symptoms such as tachycardia and malaise, which result from the use of large-sized applicators.⁴¹ Model calculations show significant improvements in control of power distribution by increasing the antenna number with the assumption of optimum adjustment of phases and amplitudes.¹⁰⁵ The Sigma-60 applicator is a widely spread applicator, which consists of four dipole antenna pairs arranged in a ring around the patient.⁶⁰ The Sigma-Eye applicator is one of the next generations of commercially available applicators, consisting of three shorter rings, each with four flat dipole-antenna pairs.¹⁰⁶

2. Regional Perfusion Hyperthermia

Regional perfusion techniques can be used to treat cancers in the arms and legs, such as melanoma, or cancer in some organs such as the liver or lung. In this procedure, some of the patient's blood is removed, heated, and then pumped (perfused) back into the limb or organ. Anticancer drugs are commonly given during this treatment. Regional hyperthermia is usually applied by perfusion of a limb, organ, or body cavity with heated fluids.^{107,108}

Much experience with hyperthermic chemoperfusion has been gained since 1970. In contrast to external heating methods, hyperthermic perfusion techniques carry the risk of severe and persisting adverse effects (for example, neuropathy and amputation of limbs). However, both hyperthermic isolated limb perfusion and hyperthermic intraperitoneal perfusion at different temperatures achieve high response rates in comparison with historical control groups receiving systemic chemotherapy. This success is due to both the homogeneous and well-controlled heat application and the much higher (more than tenfold) drug concentrations possible with this technique.⁶⁰

Hyperthermic isolated limb perfusion has been mostly used as a melphalan-based induction therapy in advanced stages of nonresectable melanomas and soft-tissue sarcomas (limited to one limb). Trials showed further improvement in response rates with addition of high doses of tumor necrosis factor, whereas application of additional drugs (especially cisplatin) is not beneficial. Because of these high response rates, no prospective randomized trials on induction therapy with hyperthermic isolated limb perfusion have yet been done.¹⁰⁹⁻¹¹¹

3. Other Regional Hyperthermic Techniques

Other hyperthermia approaches of clinical interest are under investigation for prostate cancer,¹¹² preirradiated rectal cancer, and, particularly, use of partial-body hyperthermia for peritoneal carcinosis (for ovarian cancer) in conjunction with chemotherapy (liposomal doxorubicin).⁶⁰ Continuous hyperthermic peritoneal perfusion is another technique used to treat cancers within the peritoneal cavity (the space within the abdomen that contains the intestines, stomach, and liver), including primary peritoneal mesothelioma and stomach cancer. During surgery, heated anticancer drugs flow from a warming device through the peritoneal cavity. The peritoneal cavity temperature reaches 41–42°C.

C. Whole-Body Hyperthermia (WBH)

Early attempts at WBH date back to the 1890s.¹¹³ WBH (to a limit of 42°C) is a distinctive and complex pathophysiological condition that has tremendous impact on tissue metabolism, blood flow, organ function, and tissue repair. For example, the basal metabolic rate of a patient weighing about 70 kg is 85 W at 37°C and double that at 42°C; this in itself is enough to raise the body temperature within 180 min from 37.5°C to 42°C, if thermal isolation is complete.⁶⁰ WBH has been investigated since the 1970s as an adjuvant with conventional chemo- or radiotherapy for the treatment of various malignant diseases.¹¹⁴ It is used to treat metastatic cancer that has spread throughout the body. To ensure that the desired temperature is reached, but not exceeded, the temperature of the tumor and surrounding tissue is monitored throughout hyperthermia treatment.

Three major methods are now available to achieve reproducible, controlled WBH, namely, thermal conduction (surface heating), extracorporeal induction (blood is pumped out of the patient's body, heated to 42°C or more, then put back in the body while still hot), and radiant or EM induction.^{115–117} The tolerance of liver and brain tissue limits the maximum temperature for using WBH to 41.8–42.0°C, but this temperature may be maintained for several hours. Heating can be accomplished with thermal conduction heat sources such as immersion in heated fluids,¹¹⁸ heated air,¹¹⁹ wrapping the patient in heated blankets,¹²⁰ or using thermal chambers (similar to large incubators).

WBH hyperthermia may also be used to treat AIDS. In a technique called extracorporeal hyperthermia, the blood is pumped out of the patient's body, heated to 42°C or more, then put back in the body while still hot. Extracorporeal hyperthermia treatment of bone followed by its reimplantation may be an optional treatment of bone tumors.¹²¹

EM techniques are available that use radiant heat, microwave radiation, infrared radiation, or combinations of these to induce WBH with steady-state temperatures of 41–42°C. Although the power absorption patterns are nonuniform, redistribution of the thermal energy via the circulatory system is rapid. WBH can

be combined with chemotherapy to increase tumor cell death without increasing bone marrow suppression.¹²² A newer approach is to increase the temperature to ~ 40°C for a longer period, which, in combination with cytokines and cytotoxic drugs, is expected to lead to a greater therapeutic index than WBH at the maximum tolerated level.¹²³

WBH can be applied only to patients in a good health. When combined with drugs, the first step must evidently be to demonstrate its safety.¹⁰ The toxicities associated with WBH may be significant; therefore, careful patient selection and supportive care are essential. Sedation or general anesthesia must be used and continuous monitoring of vital signs, core body temperature, cardiac function [using an electrocardiogram (ECG)], and urine output is necessary.

D. Extracellular Hyperthermia

The classical hyperthermia effect is based on well-focused energy absorption targeting the malignant tissue. The treatment temperature has been considered as the main technical parameter. There are discussions about the mechanism and control of the process because of some doubts about the micromechanisms. The main idea of the extracellular hyperthermia (or electrohyperthermia, oncothermia) is to heat up the targeted tissue by means of electric field, keeping the energy absorption within the extracellular liquid.¹²⁴ Extracellular hyperthermia is devoted to enhancing the efficiency of conventional hyperthermia by additional, nonequilibrium thermal effects with the aim of suppressing the existing disadvantages of the classical thermal treatments. Although this new technique recognizes the benefits of increased tissue temperature and its biological consequences, it also argues that nonequilibrium thermal effects are partially responsible for the observed clinical deviations from the purely temperature-based treatment theory.⁴⁹

Extracellular hyperthermia is based on a capacitively coupled energy transfer applied at a frequency that is primarily absorbed in the extracellular matrix due to its inability to penetrate the cell membrane.¹²⁵ Since the energy absorption for these effects is more significant than the temperature, it is important to characterize the hyperthermia by thermal dose and not by temperature. Thermal dose changes many energetic processes in the tissue and in their physiology. Most of the desired changes (structural and chemical) involve energy consumption.⁴⁹

IV. HYPERTHERMIA HEATING SYSTEMS

Most clinical hyperthermia systems operate by causing a target volume of tissue to be exposed to EM fields or ultrasound radiation. A structure is needed that is capable of transferring energy into biological tissue and getting the best approximation of the area to be treated by 3D distribution of SARs. The majority of

the hyperthermia treatments are applied using external devices (applicators), employing energy transfer to the tissue.^{87,88,126} User needs require that the system be effective, safe, and robust. For a heating system to be effective, it must be able to produce final time and temperature histories that include a set of tumor temperatures that can be maintained for long enough times to result in clinically effective thermal doses without also producing unacceptable normal tissue temperatures.³

A. Techniques

Facilitated by the enormous progression in computational power, the last decade has brought significant advances and innovations in the technology needed to develop RF, microwaves, and ultrasound applicators. Applicators are positioned around or near the appropriate region, and energy is focused on the tumor to raise its temperature. Currently, hyperthermia systems can be interfaced with magnetic resonance image (MRI) systems, allowing noninvasive temperature monitoring of the treatment.

1. Ultrasound

Sound is vibration. Ultrasound waves involve the propagation of sound waves at a frequency of 2–20 MHz through soft tissues. Absorption of ultrasound waves results in heating of the medium. In terms of basic physics, ultrasound has the best combination of small wavelengths and corresponding attenuation coefficient that allow penetration to deep sites with the ability to focus power into regions of small size. The primary limitation of such systems is their inability to penetrate air and the difficulty in penetrating bone.

Early ultrasound systems used single-transducer applicators that showed increased tumor temperatures compared with microwave systems. Multiple elements and frequencies can be used in order to increase the focusing of energy while maintaining good penetration depth, thus making SAR shaping by either phasing or mechanical scanning clinically feasible for superficial sites.⁵

Over the years, ultrasound devices capable of improved heating uniformity and controlled depth of penetration, mostly by using multiple applicators with phasing and power steering, have been designed.^{127–133}

2. Radiofrequency (RF)

The initial investigation of the use of RF waves in the body is credited to d'Arsonval in 1891, which showed that RF waves that pass through living tissue cause an elevation in tissue temperature without causing neuromuscular excitation. These observations eventually led to the development in the early- to mid-1900s of electrocautery and medical diathermy.^{134–137} To heat large tumors at

depth, RF fields in the range of 10–120 MHz are generally used with wavelengths that are long compared to body dimensions and, thus, deposit energy over a sizeable region.⁶⁴ Schematically, a closed-loop circuit is created by placing a generator, a large dispersive electrode (ground pad), a patient, and a needle electrode in series. Both the dispersive electrode and needle electrode are active, while the patient acts as a resistor. Thus, an alternating electric field is created within the tissue of the patient. Given the relatively high electrical resistance of tissue in comparison with the metal electrodes, there is marked agitation of the ions present in the tumor tissue that immediately surrounds the electrode. This ionic agitation creates frictional heating within the body, which can be tightly controlled through modulation of the amount of RF energy deposited.^{138–140} The tissue's resistance to current flow results in thermal lesions. The desiccated and coagulated tissue raises the resistance to current flow, impeding effective tissue heating and limiting the size of RF-induced lesions. Studies have shown that RF-induced lesions increase rapidly in size during the initial period of power application, and then the rate of increase diminishes rapidly as the resistance rises at the electrode-tissue interface and the current flow falls.^{141,142}

3. Microwaves

One of the more promising hyperthermia techniques is the use of microwaves. Microwave hyperthermia has been used on thousands of patients suffering from prostate or breast cancer. Microwave-generated heat is used to shrink and/or destroy cancerous tumors. Microwave hyperthermia has generally utilized single-waveguide microwave antennas working at 434, 915, and 2450 MHz. A hyperthermia system includes the antenna and a noncontacting temperature sensor that scan a predetermined path over the surface of tissue to be treated. The temperature sensor senses the temperature of the tissue, and a controller closes a feedback loop that adjusts the microwave power applied to the antenna in a manner that raises the temperature of the tissue uniformly. Microwave hyperthermia is frequently used in conjunction with other cancer therapies, such as radiation therapy. It can increase tumor blood flow, thereby helping to oxygenate poorly oxygenated malignant cells.

The early systems have had the heating disadvantage of having lateral SAR contours that are significantly smaller than the applicator dimensions, thus causing underheating problems in early trials when investigators used applicators that covered the tumors visually, but heated only their central region. Also, at the frequency of operation, these systems have relatively long wavelengths, limiting their ability to focus on tumors. To overcome these limitations, improved antenna-based systems and multiple-applicator systems have been used clinically for large tumors, and phasing of such systems is a possibility.³

B. External RF Applicators

1. Capacitive Heating

A useful RF approach that has been used clinically is the capacitively coupled system. This name is due to the applicator shape, which is similar to a two-plate capacitor excited by an electric potential between the plates as shown in Figure 2. Capacitor-plate applicators are typical electric field (E-type) applicators. These applicators are usually operated at either 13.56 or 27.12 MHz, two of the frequencies assigned to industrial, scientific, and medical use (ISM frequencies). Capacitive hyperthermia equipment generally consists of an RF generator, an RF power meter, an impedance-matching network, a set of electrode applicators, a temperature-control system for the applicators, a set of connecting cables, and a patient-support assembly. The RF energy is transmitted from the generator via coaxial cables to electrodes placed on opposite sides of the body, and the power is distributed locally or regionally through interaction of electric fields produced between the parallel-opposed electrodes. The adjustable positions of the electrodes permit heating at different angles and treatment sites.

RF-capacitive devices are convenient to apply to various anatomical sites. Tissues can be heated by displacement currents generated between the two capacitor plates. However, they are not robust in terms of positioning because currents tend to concentrate around the closer electrode tips when they are nonparallel. Another disadvantage is the excessive heating of subcutaneous fat. This is because the electric fields generated are normal to the skin surface and currents must pass through the high-resistance low-blood-flow superficial fatty layers, causing substantial superficial heating. It has been shown that with a patient with subcutaneous fat of more than 1.5–2 cm in thickness, which is difficult to heat with this heating modality, their related pain levels are frequently treatment limiting, even when skin precooling is applied.^{3,143,144}

With multiple-capacitor configurations,¹⁴⁵ internal heating patterns can be adjusted by changing the relative voltages applied to various plates. Ring capacitors can produce deep internal heating without overheating the surface if a proper gap is maintained between the rings and the body surface. A number

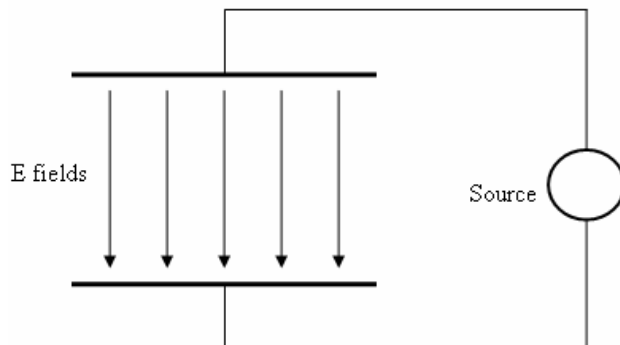

FIGURE 2. Capacitive applicator for hyperthermia.

of researchers indicate the ability of RF-capacitive systems to achieve a good regional deep heating.^{144,146-158} Results of a seven-institution Japanese trial employing the Thermotron RF-8 capacitive heating device (Yamamoto Vinyter, Osaka, Japan) are noteworthy. Treatment given to 177 patients with deep-seated tumors used hyperthermia in combination with radiation therapy alone (96 patients) or with radiochemotherapy (81 patients). Maximum intratumor or intracavitary temperatures greater than 42°C were obtained in 77% and 74% of the tumors, respectively. Response rates and symptomatic improvement were felt to be higher than expected for historical controls treated with radiation therapy or chemotherapy alone.¹⁴⁹

2. Inductive Heating

Inductive heating by coupled energy transfer from a coil carrying alternating current (AC) surrounding a biological object through air is used to achieve deeper hyperthermia (for example, more than 5 cm). Magnetic fields in RF induction heating can penetrate tissues, such as subcutaneous fat, without excessive heating. Such magnetic fields induce eddy currents inside the tissues. Since the induced E fields are parallel to the tissue interface, heating is maximized in muscle rather than in fat. However, the heating pattern is generally toroidal in shape, with a null at the center of the coil.

The simplest inductive applicator is a single coaxial current loop.¹⁶⁰ Since the coaxial current loop produces eddy-current-type E fields that circulate around the axis of the loop, heating in the center of the body is minimal. In general, inductive applicators seem not to couple as strongly to the body as capacitive applicators, and relatively high currents are usually needed to get adequate heating. Sub-

sequent use of these devices shows that they still heat a large amount of normal tissues. These applicators are usually operated at ISM frequencies of 13.56, 27.12, and 40 MHz, with the depth of penetration typically being a few centimeters.

Induction hyperthermia equipment generally consists of an RF power generator, an RF power meter, an impedance-matching network, one or more induction coil applicators, a set of connecting cables, and a patient-support assembly. An inductive applicator for hyperthermia is shown in Figure 3. A pair of cylindrical ferrite cores is used for the applicator. The distance between the pair of ferrite cores is adjustable, depending

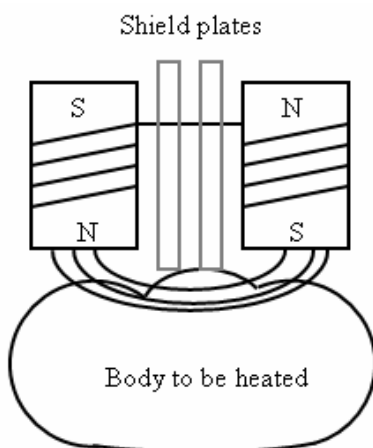

FIGURE 3. Inductive applicator for hyperthermia.

on the size of the region to be heated. The target is placed between or under the pair of ferrite cores. The time-varying magnetic field penetrating the body causes an eddy current. As a result, Joule's heat is produced. To effectively control the heating position vertically or horizontally, conductive plates to shield the magnetic field are introduced.¹⁶¹ In response to demand for clinical use, various inductive heating applicator systems have been developed and used in the long history of hyperthermia.^{156,159-163}

3. Capacitive and Inductive Heating

A heating system combining a pair of capacitively coupled electrodes and induction-aperture-type applicators is also called a hybrid heating system. Figure 4 shows schematically the inductive heating system. In this case, the currents produced by the electrodes and applicators are substantially additive in the central region of the phantom, but are substantially opposed in the superficial regions beneath the apertures of the applicators.¹⁶⁴

C. External Radiative EM Devices

One of the major problems of high-frequency EM devices is the limited depth of penetration due to the EM principle of skin depth. Only tumors located 2–3 cm from the skin surface can, therefore, be heated with conventional surface applicators.¹⁶⁵ Different types of antennas can be used as applicators, including waveguides and horns,¹⁶⁶⁻¹⁶⁹ and microstrip patches.¹⁷⁰⁻¹⁷³ To attain deeper localized heating, metal-plate lens applicators are used. These applicators can converge microwave energy in a lossy medium, such as human muscle, of up to 6 cm.¹⁷⁴

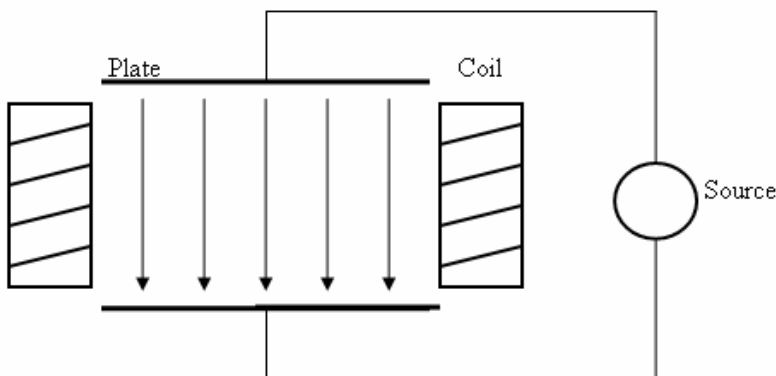

FIGURE 4. Capacitive and inductive heating system.

1. Single Applicators

Early hyperthermia trials were conducted with single-aperture devices having no ability to steer or focus energy other than shifting patient position relative to the applicator. These trials included 27 MHz ridged waveguide,¹⁶⁶ 82 MHz helix,¹⁷⁵ 70 MHz coaxial TEM applicator,¹⁶⁷⁻¹⁶⁹ and 27 to 70 MHz evanescent-mode waveguide excited below the cutoff frequency by entering a resonant circuit (lumped capacity and inductance) with a wave impedance build-up band-pass filter for the operating frequency.^{126,176} Most of the microwave equipment includes a water bolus for surface cooling. Low-profile, light-weight microstrip applicators, which are easier to use clinically, are also used. The type of applicator selected depends on the production of sufficient thermal field distributions at different depths of the tumor in a variety of anatomical sites. Single-element applicators can safely deliver optimum thermal doses to relatively small superficial tumors. Over the years, several types of applicators for external local hyperthermia have been investigated by many researchers based on the principle of a dielectric filled waveguide or horn antenna.¹⁷⁷⁻¹⁸⁵

2. Multielement Array Applicators

To increase the value of the SAR at depth relative to the surface SAR in hyperthermia therapy, we must geometrically focus energy deposition from multiple E fields generated by an array of applicators.¹⁸⁶ A basic array for external deep heating will likely consist of an annular ring of radiating apertures. The parameters of interest are the external E field within an array at the surface of the patient's body, the SAR pattern within the target volume, and the radiation leakage levels of the scattered fields around the applicator.

Several different RF electrode arrays have been investigated. Manning et al.¹⁸⁷ examined two arrays of needle electrodes arranged in two planes, with a bipolar RF current between the arrays. In the bipolar system, RF current is passed between two electrodes instead of between a single electrode and a ground path, so two electrodes heat the tissue instead of one, resulting in a larger ablation zone. Other groups investigated different array configurations,^{188,189} and segmented needle electrodes have been suggested to allow for better control of tissue heating.¹⁹⁰

An array of applicators with variations in phase, frequency, amplitude, and orientation of the applied fields can add more dimensions to controlling the heating patterns during hyperthermia cancer therapy.⁵¹ Because of the constructive interference of E fields at the intended focus and destructive interference of E fields away from the focus, multichannel coherent phased-array applicators can theoretically provide deeper tissue penetration and improved localization of the absorbed energy in deep-seated tumor regions without overheating the skin and superficial healthy tissues, compared to single or incoherent array applicators.

When comparing array applicators with a single applicator, array applicators provide deeper tissue penetration, reduce undesired heating of normal surrounding tissues between the applicator and tumor, and improve local control of the tumor temperature distribution. Heat generated by RF devices is delivered regionally across a much larger area. However, a microwave array system requires target compression because of the shallow penetration of the higher microwave frequencies. RF array applicators surrounding the body are used in attempting to heat deep tumors. However, studies in external RF array thermotherapy have shown the difficulty of localizing RF energy in malignant tissue deep within the human body without damaging superficial healthy tissue due to hot spots. Improvements in RF energy deposition are achieved when the RF phased array is controlled by an adaptive algorithm to focus the RF energy in the tumor and tumor margins, while the superficial RF fields are nullified.

Clinically, the use of phased arrays as heating applicators has several advantages. Phased arrays can easily compensate for the effects of inhomogeneities of the treatment volume (which includes the tumor and the surrounding tissues). The heating pattern can be controlled electronically, thus eliminating the need for mechanical movement of the applicator head. This simplifies the machine-patient interface and allows for better use of the available power. Also, electronic switching can be performed rapidly, thus enabling swift response to changes in the tumor environment. However, clinicians cannot always accurately predetermine or manually adjust the optimum settings for output power and phase of each antenna to focus heat reliably into deep-seated tumors.^{186,191} Figure 5 shows how hyperthermia treatment is performed, while Figure 6 illustrates the equipment

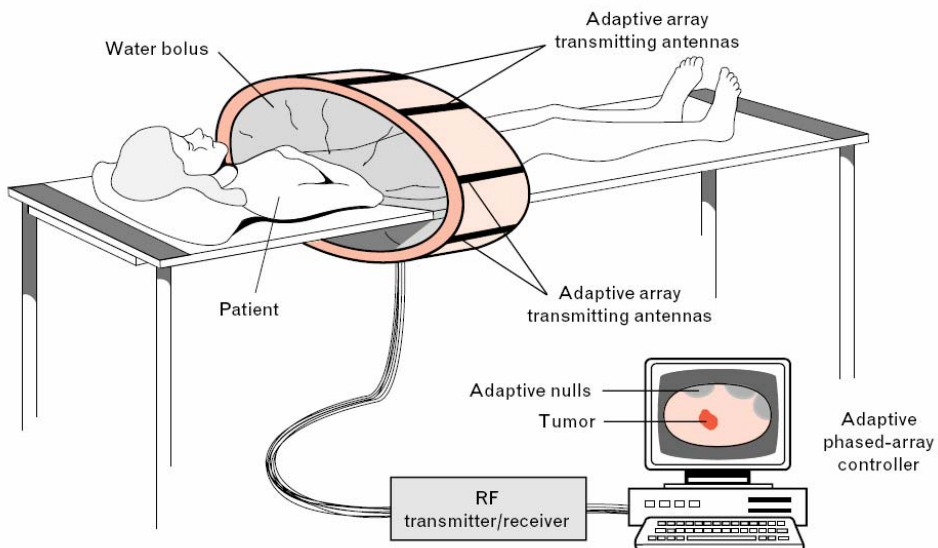

FIGURE 5. Hyperthermia treatment with RF radiative devices.¹⁸⁶

setup that performs the process of hyperthermia using an array of applicators.

Two outstanding challenges in EM phased-array hyperthermia are (1) to selectively elevate the temperature in the cancerous tissue without excessively elevating the temperature of the surrounding healthy tissues in the presence of electrical and thermodynamic inhomogeneities, and (2) to react to unexpected changes in the patient positioning and physiology (e.g., sudden change in blood flow in the tumor) that can significantly impact the quality of the delivered treatment.^{192,193}

Significant research progress has been obtained recently in heating devices appropriate for deep hyperthermia including ultrasonic arrays,^{194–208} RF arrays,^{105,209–216} and microwave arrays.^{39,137,191,192,193,217–239}

Petrovich et al.²⁴⁰ have reported the results of a 14-institution trial conducted in the United States that employed the annular phased array system for regional hyperthermia production in 353 patients with advanced, recurrent, or persistent deep-seated tumors. Hyperthermia was used alone or in conjunction with radiation therapy, or chemotherapy, chemotherapy, and radiation therapy in 4%, 12%, 13%, and 69% of the patients, respectively. Complete responses (10%) and partial responses (17%) were obtained, with the highest complete response rates noted in patients receiving radiation therapy in conjunction with hyperthermia (12% versus 2%).

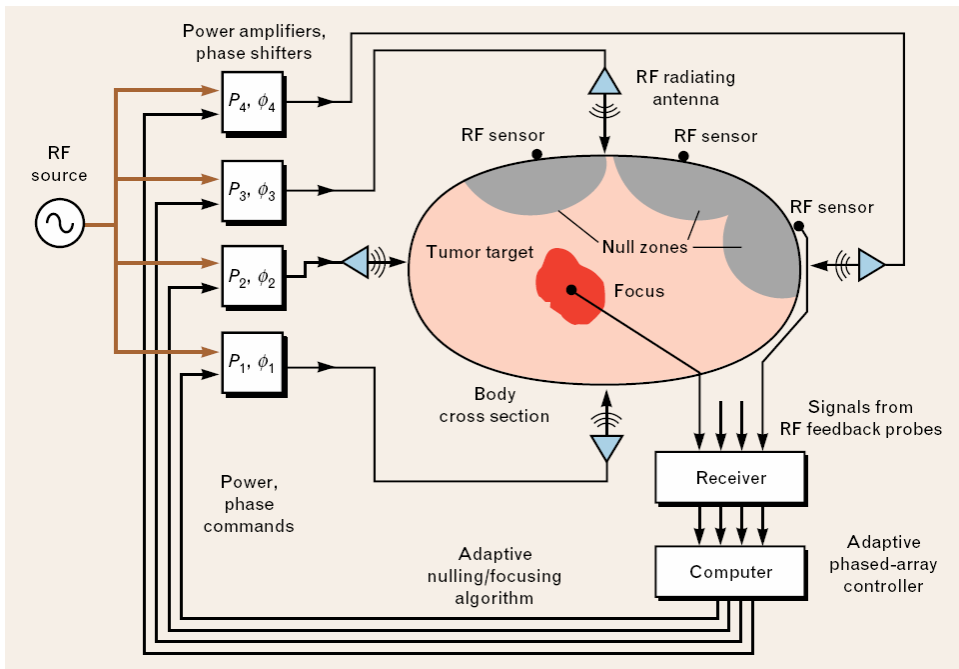

FIGURE 6. A minimally invasive system of four coherent EM radiating antennas used to heat deep-seated tumors.¹⁸⁶

Better understanding of array applicators is important, not only in the design of single antenna in the near-field range (matching, symmetrization, efficiency), but also in combining these antennas in an array. The coupling between the antennas is the most essential and critical feature, which has to be as low as possible in a well-controllable array. Transforming networks are needed to link the amplifier system and antennas. A kind of feedback control must be established between the amplifier system (for example, single generators) and a patient-adapted power distribution.⁶⁰

D. Interstitial and Intracavitary Devices

As early as 1976, it was suggested that RF currents applied between groups of stainless steel electrodes could be used to induce elevated temperatures in deep-seated (depth ≥ 3 cm) tumors.²⁴¹ The application of an alternating voltage of sufficient magnitude across planes comprising multiple pairs of such electrodes is capable of generating electrical currents through the tumor, leading to an increase of the tissue temperature. The simplicity of the basic concept accounts for increasing acceptance of interstitial probes by hyperthermia research groups, and its application to various anatomical tumor-bearing sites.

Interstitial hyperthermia is an invasive procedure where a single or an array of interstitial antennas or electrodes is implanted in accessible tumors that might be located in deep or superficial tissues. The invasiveness gives interstitial systems the clear advantage of being potentially effective (able to concentrate power into the tumor), thus potentially maximizing the tumor temperature while minimizing thermal damage to normal tissue. In addition to electrodes, the interstitial hyperthermia system includes a generator controlled with an automatic tuning system and temperature-limitation system. Temperature measurements must be performed at the antennas and between them. In most systems, every single antenna is controlled by its own generator. Dedicated systems have in addition two or more segments per antenna or electrode controlled in phase and/or amplitude. One limitation of the interstitial heating approach is the inability of the system to vary the power deposition along the radial direction, i.e., the direction perpendicular to the electrode length.

Although often compared to interstitial systems, intracavitary systems are really interior versions of superficial systems that, by using the appropriate body cavities, minimize both the amount of intervening normal tissue between the applicator and the tumor (compared with using a superficial system for the same tumor) and the amount of tissue trauma (compared with the more invasive interstitial system). Intracavitary systems are quite promising for a few important sites such as the prostate and the esophagus. More advanced systems have been developed recently, including multiple applicators in a segmented, phased-array ultrasound system.³

Accurate models of the power deposition patterns of specific applicators and

the bioheat response of the tissue to these procedures are continually being developed and improved on. These models have been important in developing treatment strategies and in the implementation of treatment planning.²⁴² Some examples of model development specific to interstitial applicator design and treatment planning include those for ultrasound,^{243–249} RF current sources,^{190,221,250–255} and microwave.^{256,261} Clinically, interstitial hyperthermia has been applied for prostate carcinoma, recurrent breast cancer and malignant brain tumors.^{101,102,261–266}

The development of partially insulated electrodes is helping significantly to reduce the temperatures in surrounding normal tissues, therefore improving the therapeutic gain. Multiple electrodes multiplexing also provide added flexibility and the means for dynamic control of power deposition during treatments.

E. Nanotechnology-Based Sources

The major problem of actually applied hyperthermia treatments is to achieve a homogenous heat distribution in the treated tissue. The currently available modalities of hyperthermia are often limited by their inability to selectively target tumor tissue and, hence, they carry a high risk of collateral organ damage or they deposit heat in a very localized manner, which can result in undertreatment of a tumor. Nanotechnology-based cancer therapy is a special form of interstitial thermotherapy with the advantage of selective heat deposition to the tumor cells. This new therapy is one of the first applications of nanotechnology in medicine and is based on heating of ferric oxide nanoparticles in an AC magnetic field. The method is also known as magnetic fluid hyperthermia (MFH) or nanocancer therapy. This technique meets the requirement of maximal deposition of heat within the targeted region under maximal protection of the surrounding healthy tissue at the same time.

Deep local inductive heating can be achieved by using an implant material, which generates heat by its interaction with the magnetic field. However, since eddy currents are predominantly induced near the surface of the human body, the result is that both the implanted region and the superficial normal tissues are being heated. Eddy-current absorbers consisting of silicon rubber containing a fine carbon powder are therefore used.

The application of biocompatible magnetic nanoparticles (in the form of ferrofluids) for diagnosis and therapeutic purposes is being considered by a growing number of biomedical researchers. Applications of this technology in biology and medicine include separation of biological materials using magnetically labeled beads,²⁶⁷ drug delivery and medicine,⁴⁵ cell sorting based on the fact that high magnetic flux density attracts magnetically labeled cells,^{268,269} and hyperthermia.^{270–274} For the first time, hyperthermia with magnetic nanoparticles enables the physician to select between different treatment temperatures after only a single injection of the nanoparticles. The process involved in the magnetic hyper-

thermia, which is based on the known hypersensitivity of tumor cells to heating, is related to energy dissipation when a ferromagnetic material is placed in an external alternating magnetic field. The technique consists of the localization of magnetic particles or seeds within tumor tissue followed by exposure to an externally applied magnetic field to cause them to heat.⁴⁴ If particles are localized into the tumor tissues in the bone, it will be easy to heat the tumor because heat quenching by the blood flow is ignored and a high hyperthermic effect will be expected.²⁷⁴ The success of such an approach depends critically on the ability to specifically attach a given particle on a certain type of cells, namely, the ones that are to be killed. This is a very complex biochemical, biological, and medical subject. Other issues to be resolved (depending on the kind of organs to be treated) are transportation to the target, neutralizing the body's immune system, minimizing the mass of magnetic material, and detection of possible accumulation of magnetic material in other organs.

Magnetically mediated hyperthermia using magnetic particles has been used in the treatment of brain tumors, tongue cancers, kidney cancers, malignant melanoma, and a hamster osteosarcoma.²⁷⁴ The physician may either choose hyperthermia conditions (up to 45°C) to intensify conventional therapies such as radiation or chemotherapy, or thermoablation by using higher temperatures up to 70°C. Clinically, this technique may provide the potential to address many shortcomings of other delivery systems.

For clinical applications, magnetic materials should present low levels of toxicity as well as a high saturation magnetic moment in order to minimize the doses required for temperature increase. Currently, magnetite (Fe_3O_4) is used in this process because it presents a high Curie temperature and high saturation magnetic moment (90–98 emu/g, or $\sim 450\text{--}500$ emu/cm³), and has shown the lowest toxicity index in preclinical tests. On the other hand, it should be carefully investigated whether long-term deposits of magnetite affects patient health, that is, acute and/or chronic toxicity by excess absorption of Fe ions.²⁷⁵

V. HYPERTHERMIA COMBINED WITH OTHER MODALITIES

Hyperthermia has been used for the treatment of resistant tumors of many kinds, but still with unsatisfactory results. Hyperthermia can be used by itself, and results in shrinkage and sometimes complete eradication of tumors. However, these results may not last, and the tumors can regrow. Most tumor sites are unreachable with the present interstitial, superficial, and regional hyperthermia techniques alone. Furthermore, for the limited number of sites that are heatable, dosimetric studies indicate that the temperature distributions reached are highly inhomogeneous and that it is almost impossible to obtain the protocol temperature goals.^{242,276–280} Accordingly, the most beneficial contribution of hyperthermia for oncological treatments will be based on enhancing the effectiveness of other treatment modalities (including radiotherapy, chemotherapy, radiochemotherapy,

gene therapy, and immune therapy).

The biological rationale for hyperthermia applied in combination with radiotherapy or chemotherapy is well established and appears promising; in particular, the sensitivity of hypoxic cells to heating makes hyperthermia an ideal adjunct to standard radiotherapy.²⁸¹ Hyperthermia produces direct injury by damaging the entire cellular machinery, including nucleic acids, the cytoskeleton, and cell membranes. Radiotherapy and many chemotherapeutic agents have similar mechanisms of action. There are reports of synergistic effects of regional or WBH for cancer treatments that include radiotherapy, bleomycin, mitomycin C, Adriamycin, 5-fluorouracil, cisplatin, and carboplatin.²⁸²

Falk and Issels⁵⁹ conducted an extensive review on the state of the art of hyperthermia in the year 2000 describing the effect of hyperthermia combined with radiotherapy, chemotherapy, or both. All the considered studies but two show a statistically significant higher (up to a doubling) tumor control and/or cure rate for the combined treatment modality. The positive results of most of the studies explain the renewed enthusiasm in hyperthermia, which is reflected in the growing number of institutes interested in the application of hyperthermia.^{57,69,283}

A. Hyperthermia and Radiation

The synergistic effects of hyperthermia combined with radiation have been investigated and reported to yield higher complete and durable responses than radiation alone in superficial tumors. Several mechanisms are responsible for the supra-additive effect of the combination of radiotherapy and hyperthermia. The additive effect comes from the sensitivity of cells in the hypoxic, low pH areas, and the cells in the S-phase, which are both relatively radioresistant.⁴ Hyperthermia may cause an increased blood flow, which may result in an improvement in tissue oxygenation, which then results in a temporally increased radiosensitivity.²⁸⁴ Clinical data and experiments *in vivo* show hyperthermia at mild temperatures, easily achievable with the use of presently available clinical hyperthermia devices, increases perfusion in the tumor region, leading to a higher oxygen concentration. Higher perfusion can increase drug delivery and reoxygenation. Most human tumors have increased blood flow both under hyperthermia and hours later. Only a few cases of human tumors have shown vascular breakdown.^{285,286}

Biologically, hyperthermia has two different types of interactions with radiation. First, heat has a radiosensitizing effect. This is most prominent with simultaneous application, but is of the same magnitude in both tumor and normal tissue, and will not improve the therapeutic ratio unless the tumor is heated to a higher temperature than the normal tissue. Second, hyperthermia exhibits a direct cytotoxic effect, and a moderate heat treatment alone can almost selectively destroy tumor cells in a nutritionally deprived chronically hypoxic and acidic environment. Because such cells are the most radioresistant, a smaller radiation dose is needed to control the remaining more radiosensitive cells. Clinically, heating

of superficial tumors (such as breast tumors, neck nodes, and malignant melanoma) has confirmed the biological rationale for using hyperthermia as an adjuvant to radiotherapy.²⁸⁷

Combined hyperthermia and radiation offers potential clinical advantages for treatment of tumors. Importantly, the synergy between radiation and heat is highly dependent on the order of application and highest when given simultaneously. It has been reported by many clinical trials that hyperthermia therapy has been shown to substantially improve local control of cancer, tumor clinical response, and survival rates when added to radiation treatments. It yields considerable therapeutic gain compared to radiation alone in treating various cancerous tumors.^{54,56,149,154,159,186,278,287-305} However, not all studies have shown increased survival in patients receiving the combined treatments.^{2,59,60,306}

A disadvantage intrinsically associated with hyperthermia is that one heat treatment can cause a transient resistance against a subsequent treatment (thermotolerance). In radiotherapy, a standard treatment regimen consists of a six week course of radiation doses. If one would like to apply hyperthermia with each of these radiation treatments, this thermotolerance would certainly negatively interfere with the effectiveness of the treatment. Therefore, the mechanisms underlying thermotolerance are being extensively explored to find ways to minimize its development.

B. Hyperthermia and Chemotherapy

In clinical practice, it is difficult to deliver therapeutic amounts of infused chemotherapy to solid tumors deep in the body without incurring toxic effects in healthy body organs. Limited amounts of free chemotherapy infused into the bloodstream reach the tumor due to damaged vasculature in the vicinity of the tumor and also due to tumor cell pressure that blocks the chemotherapy from passing through the cell membrane. A number of clinical studies have established that elevated cell tissue temperature, induced by EM energy absorption, significantly enhances the effectiveness of chemotherapy in the treatment of malignant tumors in the human body without increasing the infused amount of drug.^{59,95,307}

For the combination of hyperthermia and chemotherapy, spatial cooperation can again explain the additive effects. Drug concentration will be less in the insufficiently perfused tumor regions. When it comes to chemotherapy, there are indications that some chemotoxicity can be potentiated by hyperthermia. The important mechanisms for an interactive effect are increased intracellular drug uptake, enhanced DNA damage, and higher intratumor drug concentrations, resulting from an increase in blood flow. An interactive effect was observed for virtually all cell lines treated at temperatures above 40°C for alkylating agents, nitrosureas, and platin analogues, with enhancement ratios depending on temperature and exposure time. The effect of these drugs can be enhanced by a factor of between 1.2 and 10, and an extremely high thermal enhancement ratio of 23

was even observed for in vitro application of melphalan to drug-resistant cells at 44°C.³⁰⁸ In combination with chemotherapy, the type of drug, dose, temperature, and time of administration all play a role in determining the effect of treatment.

Improvement of local control by hyperthermia combined with systemic chemotherapy was observed by many researchers.^{309–319} There is insufficient information to make conclusions regarding the use of WBH as an adjunct to either radiation or chemotherapy, and inadequate data regarding the use of local hyperthermia in conjunction with chemotherapy alone. This practice is based, in part, on an initial body of evidence consisting of phase I and II clinical studies describing the technical feasibility of WBH.^{318,320–324}

Extensive reviews on the combination of hyperthermia with chemotherapy have been published.^{59,84}

C. Hyperthermia and Radiochemotherapy

Radiochemotherapy is a widely used means of treatment for patients suffering from primary, locally advanced, or recurrent rectal cancer. The efficacy of treatment can be enhanced by additional application of regional hyperthermia to this conventional therapy regime. Many researchers conducted investigations on the effectiveness of hyperthermia combined with radiochemotherapy in the treatment of cancer.^{325–333} An extensive review on the combination of hyperthermia with radiochemotherapy was published in 2001.⁵⁹

D. Hyperthermia and Gene Therapy

Gene therapy may be defined as the treatment in which genetic material is introduced in a cell to enhance or modify its function. This results in the manufacture of protein(s) that are either directly therapeutic or interact with other substances to exert a therapeutic effect. In order to treat cancer effectively, the genetic material must exert its effect only on tumor or tumor-associated cells, not on normal cells, and must not eliminate the body's immune response that is so critical in fighting cancer. In order to achieve these goals, an approach must be developed that combines fever-range WBH with a gene that only affects tumor cells spliced with additional genetic material designed to cause the suicide gene to be expressed predominantly in tumor cells. Hyperthermia is expected to help in opening up the pores of tumor blood vessels so that more liposomes reach the tumors and deliver their DNA content to tumor cells. It also increases the amount of protein created by the incorporated DNA and boosts the immune system so that it sends specialized cells into the tumors to help kill them.

Gene-infected cells were found to be more sensitive to hyperthermia.^{334–336} In a murine system, intratumorally injected viral gene therapy encoding for interleukin-12, controlled with a heat-shock promoter and followed by hyperthermia,

was shown to be feasible and therapeutically effective, with no apparent systemic toxicity.³³⁷

VI. CHALLENGES AND FUTURE TRENDS

Hyperthermia is an emerging therapy method in oncology. It has been an effective modality of cancer treatments, showing significant improvements in clinical responses for many patients when used alone or in combination with other treatment methods, such as surgery, chemotherapy, radiation therapy, and gene therapy.⁴⁹ The clinical exploitation of hyperthermia was and is still hampered by various challenges including the high degree of interdependency between physiology and biology, technical and clinical limitations, and standardization.

A. Biological and Physiological Mechanisms

An important unresolved factor involves the biological and physiological mechanisms by which hyperthermia works.³ Although hyperthermic cell killing has been demonstrated in many *in vitro* studies, the mechanisms underlying cell damage and death have not been fully elucidated. Further work is required toward this end, and information from research studies on the effects of hyperthermia on tumors *in vivo* will be valuable.

Until the underlying mechanisms by which positive clinical results have been obtained are understood and the spatial and temporal distributions of the important biological and physiological variables are known, it will remain impossible to set precise engineering design goals.³

B. Technical and Clinical Challenges

Realization of the potential of hyperthermia as a primary therapy depends on the advances that must be made in EM heating techniques and thermometry.³⁴ Many major technical advances have been applied in biological and clinical research; the resulting improvements in instrumentation have helped in conducting more accurate and elegant experiments to produce heat for hyperthermia treatment including ultrasound, RF, and microwaves. Table 1 summarizes the major hyperthermia methods currently in use.

Recent developments in hyperthermia have expanded the treatment options of patients with certain types of cancer. The effectiveness of hyperthermia treatment is related to the temperature achieved during the treatment, as well as the length of treatment and cell and tissue characteristics. Control of the heating process as a major part of hyperthermia should be improved to ensure that increased temperature levels can be properly maintained, delivered, and localized within the tumor region. Effective control of the heating distribution will require

TABLE 1
Summary of Major Hyperthermia Methods

Heating approach	Advantages	Disadvantages	Application
Ultrasound	Good focus performance in tissue. No hot spots in fatty tissues. Heating possible to 5–10 cm depth with single transducer and up to 20 cm depth with multiple transducers. Temperature is easy to measure and control.	Heating area is small. No penetration of tissue-air interfaces.	Treatment of superficial and deep regional tumors. Examples include surface lesions, head and neck, and lesions in extremities.
Radiofrequency	Simple instrumentation. No shield required. Large treatment area. Electrodes not limited in size, and insulation can be accomplished.	Difficult to control electric fields. Only areas where fat is thin can be treated by capacitive systems.	Treatment for large and superficial tumors in neck, limb, chest, brain, abdomen, etc.
Microwaves	Technology very advanced. Heating large volumes is possible. Specialized antennas for heating from body cavities have been developed. Multiple applicators, coherent or incoherent, can be used. Can avoid hot spots in the fatty tissues.	Heating not localized at depth; limited penetration at high frequencies. Temperature measurement is difficult and thermometry requires noninteracting probes. Possible health effects on personnel. Shielding of treatment rooms required, except at medically reserved frequencies (915 MHz).	For treatment of superficial tumors in breast, limb, prostate, and brain.

(1) sophisticated controllers that can properly steer the power deposition to achieve close-to-optimal temperatures and (2) accurate measurements of the spatial and temporal distributions of temperature during the treatment. The theoretical evaluations and simulations of such controllers have been evolving from single-point controllers to more complex model-based controllers^{192,193,338} that can control the complete temperature in the heated region.

The lack of needed engineering tools can be viewed as a major stumbling block to hyperthermia's effective clinical implementation. Developing clinically effective systems will be difficult, however, because it requires solving several complex engineering problems for which setting appropriate design and evaluation goals is currently difficult owing to a lack of critical biological, physiological, and clinical knowledge, tasks that must be accomplished within a complicated social/political structure.³

Although hyperthermia requires investments in equipment and personnel training, the same is true for other types of cancer treatment modalities. Another obstacle in the acceptance of hyperthermia may be the lack of public awareness of this technique. Most of the clinical studies are on the application of hyperthermia in combination with radiotherapy. However, the experimental and the

few clinical results with combined chemotherapy and hyperthermia indicate that this combination is also worth further testing.¹⁰ Carefully conducted phase III trials with rigorous quality assurance must employ prospective thermal dosimetry to validate the role of hyperthermia in multimodality therapy.⁶⁸

C. Standardization

A number of challenges must be overcome before hyperthermia can be considered a standard treatment for cancer.^{2,10,60,68} Hyperthermia suffers from a lack of dosing and treatment standardization and scientific consensus about its effects on malignant and healthy tissues. In order that hyperthermia will gain widespread approval and clinical use, the technique requires further research and standardization.⁴⁹ Standardization of equipment between centers must be achieved before large-scale trials can be realized.³⁴ Two major factors make standardization of hyperthermia treatment difficult. First, there is no clear clinical thermal dose-effect relationship. This is compounded by the inability to consistently produce a uniform pattern of heat distribution throughout the tumor mass. The second major issue relates to thermal dosimetry; specifically, the inability to predict or measure accurately the temperature throughout the tumor mass and the surrounding healthy tissues. Thermal dose formulations that have taken into account both the temperature distribution and time at various temperatures have shown good correlations with complete response rates²⁷⁶ and duration of local tumor control.³³⁹ These need to be confirmed in future clinical trials.

D. Future Research

In conclusion, hyperthermia is not yet a fully developed modality; there are still problems with its routine clinical application, and there is still room for further technological improvements. We believe that the development of hyperthermia is an example of a valuable research program that is clearly important and from which physicians and patients will benefit..

REFERENCES

1. Ned B, Hornback MD. Is the community radiation oncologist ready for clinical hyperthermia? *RadioGraphics*. 1987;7:139–49.
2. Kapp DS, Hahn GM, Carlson RW. Principles of hyperthermia. In: Bast RC Jr, Kufe DW, Pollock RE, Weichselbaum RR, Holland JF, Frei EF, editors. *Cancer medicine*. Hamilton, Ontario: Decker; 2000. p. 479–88.
3. Roemer RB. Engineering aspects of hyperthermia therapy. *Ann Rev Biomed Eng*. 1999;1:347–76.

4. Raaphorst GP. Fundamental aspects of hyperthermic biology. In: Field SB, Hand JW, editors. *An introduction to the practical aspects of clinical hyperthermia*. London: Taylor & Francis, 1990. p. 10–54.
5. Fajardo LF. Pathological effects of hyperthermia in normal tissues. *Cancer Res.* 1984;44:4826s–35s.
6. Dewey WC. Arrhenius relationships from the molecule and cell to the clinic. *Int J Hyperthermia.* 1994;10:457–83.
7. Bush W. *Über den Einfluss wetchen heftigere Erysipelen zuweilen auf organisierte Neubildungen dusuben.* *Verh Natruch Preuss Rhein Westphal.* 1886;23:28–30.
8. Westermarck F. *Über die Behandlung des ulcerirenden Cervix carcinoma mittels Knonstanter Wärme.* *Zentralbl Gynkol.* 1898;1335–9.
9. Vander Vorst A, Rosen A, Kotsuka Y. *RF/microwave interaction with biological tissues.* New York: Wiley-IEEE; 2006.
10. Van der Zee J. Heating the patient: a promising approach? *Ann Oncol.* 2002;13:1173–84.
11. Urano M, Douple EB. *Hyperthermia and oncology. Vol 1. Thermal effects on cells and tissues.* Utrecht: VSP; 1988.
12. Urano M, Douple EB. *Hyperthermia and oncology. Vol 2. Biology of thermal potentiation of radiotherapy.* Utrecht: VSP; 1989.
13. Urano M, Douple EB. *Hyperthermia and oncology. Vol 3. Interstitial hyperthermia: physics, biology and clinical aspects.* Utrecht: VSP; 1992.
14. Urano M, Douple EB. *Hyperthermia and oncology. Vol 4. Chemopotential by hyperthermia: biology and clinical aspects.* Utrecht: VSP; 1994.
15. Hahn GM. *Hyperthermia and cancer.* New York: Plenum; 1982.
16. Handl-Zeller L, editor. *Interstitial hyperthermia.* Vienna: Springer-Verlag; 1992.
17. Gautherie M, Robins HI, Cohen, JD, Neville AJ, Editors. *Whole body hyperthermia: biological and clinical aspects.* Berlin: Springer-Verlag; 1992.
18. Leibel SA, Phillips TL. *Textbook of Radiation Oncology.* Philadelphia: Saunders; 1998.
19. Baronzio GF, Hager ED, Editors. *Locoregional radiofrequency-perfusional and whole body hyperthermia in cancer treatment: new clinical aspects.* New York: Springer Science Business Media and Eurekah.com; 2005.
20. Baronzio GF, Hager ED, editors. *Hyperthermia in cancer treatment: a primer.* Berlin: Springer-Verlag, 2006.
21. Christensen DA. *Thermometry and thermography.* In: Storm FK, editor. *Hyperthermia in cancer therapy.* Boston: GK Hall Medical Publishers; 1983. p. 223–32.
22. Dewhirst MW. *Considerations for hyperthermia clinical trial designs.* In: Seegenschmiedt MH, Fessenden P, Vernon CC. editors. *Principles and practice of thermoradiotherapy and thermochemotherapy. Vol II.* Berlin: Springer-Verlag; 1996 p. 361–72.

23. Sneed PK, Stauffer PR, Li G, Steege G. Hyperthermia. In: Leibel SA, Phillips TL, editors. *Textbook of radiation oncology*. 2nd ed. Philadelphia: WB Saunders; 1998. p. 1241–62.
24. Stauffer PR. Thermal therapy techniques for skin and superficial tissue disease. In: Ryan TP, editor. *Critical reviews, matching the energy source to the clinical need*. Bellingham: SPIE; 2000 p. 327–67.
25. Stauffer PR, Diederich CJ, Pouliot J. *Thermal therapy for cancer*, AAPM Monograph Series, Melville, NY: AIP; 2005.
26. Lele PP. Induction of deep, local hyperthermia by ultrasound and electromagnetic fields: problems and choices. *Radiat Environ Biophys*. 1980;17:205–17.
27. Schwan HP. Electromagnetic and ultrasonic induction of hyperthermia in tissue-like substances. *Radiat Environ Biophys*. 1980;17:189–203.
28. Sterzer E. Localized hyperthermia treatment of cancer. *RCA Rev*. 1981;42:727–51.
29. Christensen DA, Durney CH. Hyperthermia production for cancer therapy: a review of fundamentals and methods. *J Microw Power*. 1981;16:89–105.
30. Oleson JR. A review of magnetic induction methods for hyperthermia treatment of cancer. *IEEE Trans Microw Theory Tech*. 1982;30:1149–57.
31. Strohbehn JW, Roemer RB. Survey of computer simulations of hyperthermia treatments. *IEEE Trans Biomed Eng*. 1984;31:136–49.
32. Cheung AY, Neyzari A. Deep local hyperthermia for cancer therapy: external electromagnetic and ultrasound techniques. *Cancer Res*. 1984;44:4736s–44s.
33. Abe A, Hiraoka M. Localized hyperthermia and radiation in cancer therapy. *Int J Rad Biol*. 1985;47:347–59.
34. Conway J, Anderson AP. Electromagnetic techniques in hyperthermia. *Clin Phys Physiol Meas*. 1986;7:287–318.
35. Field SB. 1985 Douglas Lea Memorial Lecture. Hyperthermia in the treatment of cancer. *Phys Med Bio*. 1987;32:789–811.
36. Stuchly MA, Stuchly SS. Measurements of electromagnetic fields in biomedical applications. *Crit Rev Biomed Eng*. 1987;14:241–88.
37. Hand JW. Heat delivery and thermometry in clinical hyperthermia. *Recent Results Cancer Res*. 1987;104:1–23.
38. Cheung AY. Microwave hyperthermia for cancer therapy. *IEE Proc*. 1987;134:493–522.
39. Magin RL, Peterson AF. Noninvasive microwave phased arrays for local hyperthermia: a review. *Int J Hyperthermia*. 1989;5:429–50.
40. Fessenden P, Hand JW. Hyperthermia therapy physics. In: Smith AR, Editor. *Medical radiology: radiation therapy physics*. Berlin: Springer-Verlag, pp. 315–63, 1995.
41. Hiraoka M, Mitsumori M, Hiroi N, Ohno S, Tanaka T, Kotsuka Y, Sugimachi K. Development of RF and microwave heating equipment and clinical applications to cancer treatment in Japan. *IEEE Trans Microw Theory Tech*. 2000;48:1789–99.

42. Vaezy S, Andrew M, Kaczkowski P, Crum L. Image-guided acoustic therapy. *Annu Rev Biomed Eng.* 2001;3:375–90.
43. Gel'vich EA, Mazokhin VN. Technical aspects of electromagnetic hyperthermia in medicine. *Crit Rev Biomed Eng.* 2001;29:77–97.
44. Moroz P, Jones SK, Gray BN. Magnetically mediated hyperthermia: current status and future directions. *Int J Hyperthermia.* 2002;18:267–84.
45. Saiyed ZM, Telang SD, Ramchand CN. Application of magnetic techniques in the field of drug discovery and biomedicine. *BioMagn Res Technol.* 2003;1:42–5.
46. Chou C-K. Evaluation of microwave hyperthermia applicators. *Bioelectromagnetics.* 2005;13:581–97.
47. Haemmerich D, Lee FT. Multiple applicator approaches for radiofrequency and microwave ablation. *Int J Hyperthermia.* 2005;21:93–106.
48. Szasz A, Szasz O, Szasz N. Physical background and technical realizations of hyperthermia. In: Baronzio GF, Hager ED, editors. *Locoregional radiofrequency-perfusional and whole-body hyperthermia in cancer treatment: new clinical aspects.* New York: Springer Science Business Media and Eurokah.com; 2005.
49. Giammaria F, Andras S. Hyperthermia today: electric energy, a new opportunity in cancer treatment. *J Cancer Res Ther.* 2006;2:41–6.
50. Dutreix J, Le Bourgeois JP, Salama M. The treatment of the tumors by hyperthermia. *J Radiol Electrol Med Nucl.* 1978;59:323–34.
51. Chou C-K. Application of electromagnetic energy in cancer treatment. *IEEE Trans Instrum Meas.* 1988;37:547–51.
52. Valdagni R, Amichetti M. Report of long-term follow-up in a randomized trial comparing radiation therapy and radiation therapy plus hyperthermia to metastatic lymph nodes in stage IV head and neck patients. *Int J Radiat Oncol Biol Phys.* 1994;28:163–9.
53. Pontiggia P, Rotella GB, Sabato A, Curto FC. Therapeutic hyperthermia in cancer and AIDS: an updated survey. *J Environ Pathol Toxicol Oncol.* 1996;15:289–97.
54. Overgaard J, Gonzalez Gonzalez D, Hulshof MC, Arcangeli G, Dahl O, Mella O, Bentzen SM. Randomised trial of hyperthermia as adjuvant to radiotherapy for recurrent or metastatic malignant melanoma. *Lancet.* 1995;345:540–3.
55. Seegenschmiedt MH, Fessenden P, Vernon CC. *Thermoradiotherapy and Thermochemotherapy, Vol 2. Clinical Applications.* Berlin:Springer Verlag; 1996.
56. Vernon CC, Hand JW, Field SB, Machin D, Whaley JB, van der Zee J, van Putten WL, van Rhoon GC, van Dijk JD, Gonzalez Gonzalez D, Liu FF, Goodman P, Sherar M. Radiotherapy with or without hyperthermia in the treatment of superficial localized breast cancer: results from five randomized controlled trials. *Int J Radiat Oncol Biol Phys.* 1996;35:1117–21.
57. Dewhirst MW, Prosnitz L, Thrall D, Prescott D, Clegg S, Charles C, MacFall J, Rosner G, Samulski T, Gillette E, LaRue S. Hyperthermic treatment of malignant diseases: current status and a view toward the future. *Semin Oncol.* 1997;24:616–25.

58. Dewhirst MW, Kong MW. Review hyperthermia and liposomes. *Int J Hyperthermia*. 1999;15:345–70.
59. Falk MH, Issels RD. Hyperthermia in oncology. *Int J Hyperthermia*. 2000;17:1–18.
60. Wust P, Hildebrandt B, Sreenivasa G, Rau B, Gellermann J, Riess H, Felix R, Schlag PM. Hyperthermia in combined treatment of cancer. *Lancet Oncol*. 2002;3:487–97.
61. Feldman AL, Libutti SK, Pingpank JF, Bartlett DL, Beresnev TH, Mavroukakis SM, Steinberg SM, Liewehr DJ, Kleiner DE, Alexander HR. Analysis of factors associated with outcome in patients with malignant peritoneal mesothelioma undergoing surgical debulking and intraperitoneal chemotherapy. *J Clin Oncol*. 2003;21:4560–7.
62. Dewhirst MW, Jones E, Samulski TV, Vujaskovic Z, Li C, Prosnitz L. Hyperthermia. In: Kufe D, Pollock R, Weichelbaum R, Gansler RBT, Holland J, Rei EF, editors. *Cancer medicine*. 6th ed. Hamilton BC: Decker, p. 623–36, 2003.
63. Haveman J, Van Der Zee J, Wondergem J, Hoogeveen JF, Hulshof MC. Effects of hyperthermia on the peripheral nervous system: a review. *Int J Hyperthermia*. 2004;20:371–91.
64. Stauffer PR. Evolving technology for thermal therapy of cancer. *Int J Hyperthermia*. 2005;21:731–44.
65. Diederich CJ. Thermal ablation and high-temperature thermal therapy: Overview of technology and clinical implementation. *Int J Hyperthermia*. 2005;21:745–53.
66. Kampinga HH. Cell biological effects of hyperthermia alone or combined with radiation or drugs: a short introduction to newcomers in the field. *Int J Hyperthermia*. 2006;22:191–96.
67. Issels RD. High-risk soft tissue sarcoma: Clinical trial and hyperthermia combined chemotherapy. *Int J Hyperthermia*. 2006;22:235–9.
68. Jones E, Thrall D, Dewhirst MW, Vujaskovic Z. Prospective thermal dosimetry: the key to hyperthermia's future. *Int J Hyperthermia*. 2006;22:247–53.
69. Van Rhoon GC, Wust P. Introduction: Non-invasive thermometry for thermotherapy. *Int J Hyperthermia*. 2005;21:489–95.
70. Gerard C, Rhoon V, Wust P. Introduction: non-invasive thermometry for thermotherapy. *Int J Hyperthermia*. 2005;21:489–95.
71. Dewhirst MW, Ozimek EJ, Gross J, Cetas TC. Will hyperthermia conquer the elusive hypoxic cell? Implications of heat effects on tumor and normal-tissue microcirculation. *Radiology*. 1980;137:811–7.
72. Goldstein LS, Dewhirst MW, Repacholi M, Kheifets L. Summary, conclusions and recommendations: adverse temperature levels in the human body. *Int J Hyperthermia*. 2003;19:373–84.
73. Lepock JR, Frey HE, Ritchie KP. Protein denaturation in intact hepatocytes and isolated cellular organelles during heat shock. *J Cell Biol*. 1993;122:1267–76.
74. Lepock JR. Role of nuclear protein denaturation and aggregation in thermal radiosensitization. *Int J Hyperthermia*. 2004;20:115–30.

75. Lepock JR. How do cells respond to their thermal environment? *Int J Hyperthermia*. 2005;21:681–7.
76. Spiro IJ, Denman DL, Dewey WC. Effect of hyperthermia on CHO DNA polymerases α and β . *Radiat Res*. 1982;89:134–49.
77. Michels AA, Kanon B, Konings AWT, Ohtsuka K, Bensaude O, Kampinga HH. HSP70 and HSP40 chaperone activities in the cytoplasm and the nucleus of mammalian cells. *J Biol Chem*. 1997;272:33283–9.
78. Read RA, Bedford JS. Thermal tolerance. *Br J Radiol*. 1980;53:920–1.
79. Armour EP, McEachern D, Wang Z, Corry P, Martinez A. Sensitivity of human cells to mild hyperthermia. *Cancer Res*. 1993;53:2740–4.
80. Morimoto RI, Tissieres A, Georgopoulos C. *Stress proteins in biology and medicine*. New York: Cold Spring Harbor; 1990.
81. Hahn GM, Adwankar MK, Basrur VS, Anderson RL. Survival of cells exposed to anticancer drugs after stress. In: Pardue ML, Feramisco JR, Lindquist S, editors. *Stress-induced proteins*. New York: Liss; 1989. p. 223–33.
82. Kampinga HH, Dikomey E. Hyperthermic radiosensitization: mode of action and clinical relevance. *Int J Rad Biol*. 2001;77:399–408.
83. Kampinga HH, Turkel-Uygur N, Roti Roti JL, Konings AWT. The relationship of increased nuclear protein content induced by hyperthermia to killing of HeLa S3 cells. *Rad Res*. 1989;117:511–22.
84. Dahl O. Interaction of heat and drugs in vitro and in vivo. In: Seegenschmiedt MH, Fessenden P, Vernon CC, editors. *Thermoradiotherapy and thermochemotherapy*. Vol 1. Berlin: Springer-Verlag; 1995. p. 103–21.
85. Hettinga JVE, Konings ATW, Kampinga HH. Reduction of cisplatin resistance by hyperthermia: a review. *Int J Hyperthermia*. 1997;13:439–57.
86. Hildebrandt B, Wust P, Ahlers O, Dieing A, Sreenivasa G, Kerner T, Felix R, Riess H. The cellular and molecular basis of hyperthermia. *Crit Rev Oncol Hemato*. 2002;43:33–56.
87. Lee ER. Electromagnetic superficial heating technology. In: Seegenschmiedt MH, Fessenden P, Vernon CC, editors. *Thermoradiotherapy and thermochemotherapy*. Berlin: Springer-Verlag; 1995. p. 193–217.
88. Wust P, Seebass M, Nadobny J, Felix R. Electromagnetic deep heating technology. In: Seegenschmiedt MH, Fessenden P, Vernon CC, editors. *Thermoradiotherapy and thermochemotherapy*. Berlin: Springer-Verlag; 1995. p.219–51.
89. Myerson RJ, Moros E, Roti Roti JL. Hyperthermia. In: Perez CA, Brady LW, Editors. *Principles and practice of radiation oncology*, Philadelphia: Lippincott-Raben; 1997. p. 637–83.
90. Wust P, Gellermann J, Beier J, Wegner S, Tilly W, Troger J, Stalling D, Oswald H, Hege HC, Deufflhard P, Felix R. Evaluation of segmentation algorithms for generation of patient models in radiofrequency hyperthermia. *Phys Med Biol*. 1998;43:3295–307.

91. Van Rhoon GC, Rietveld PCM, Van der Zee J. A 433 MHz lucite cone waveguide applicator for superficial hyperthermia. *Int J Hyperthermia*. 1998;14:13–27.
92. Rietveld PJM, Van Putten WLJ, Van der Zee J, Van Rhoon GC. Comparison of the clinical effectiveness of the 433 MHz Lucite Cone applicator with that of a conventional waveguide applicator in applications of superficial hyperthermia. *Int J Radiat Oncol Biol Phys*. 1999;43:681–7.
93. Sugimachi K, Inokuchi K. Hyperthermochemoradiotherapy and esophageal carcinoma. *Semin Surg Oncol*. 1986;2:38–44.
94. Sugimachi K, Kitamura K, Baba K, Ikebe M, Ikebe M, Morita M, Matsuda H, Kuwano H. Hyperthermia combined with chemotherapy and irradiation for patients with carcinoma of the oesophagus—a prospective randomized trial. *Int J Hyperthermia*. 1992;8:289–95.
95. Sugimachi K, Kuwano H, Ide H, Toge T, Saku M, Oshiumi Y. Chemotherapy combined with or without hyperthermia for patients with oesophageal carcinoma: a prospective randomized trial. *Int J Hyperthermia*. 1994;10:485–93.
96. Kitamura K, Kuwano H, Watanabe M, Nozoe T, Yasuda M, Sumiyoshi K, Saku M, Sugimachi K. Prospective randomized study of hyperthermia combined with chemoradiotherapy for esophageal carcinoma. *J Surg Oncol*. 1995;60:55–8.
97. Saeki H, Kawaguchi H, Kitamura K, Ohno S, Sugimachi K. Recent advances in preoperative hyperthermochemoradiotherapy for patients with esophageal cancer. *J Surg Oncol*. 1998;69:224–9.
98. Fuwa N, Nomoto Y, Shouji K, Kodaira T, Kamata M, Ito Y. Therapeutic effects of simultaneous intraluminal irradiation and intraluminal hyperthermia on oesophageal carcinoma. *Br J Radiol*. 2001;74:709–14.
99. Fuwa N, Nomoto Y, Shouji K, Nakagawa T, Ito Y, Kikuchi Y. Simultaneous intraluminal irradiation and hyperthermia treatment for esophageal carcinoma. *Nippon Igaku Hoshasen Gakkai Zasshi*. 1995;55:993–5.
100. Freudenberg S, Rewerk S, Bay F, Al Khouri C, Wagner A, Isaac M, Gebhard MM, Kähler G. Local application of hyperthermia in the esophagus with a heatable malleable thermoplastic stent. *Eur Surg Res*. 2006;38:42–7.
101. Lin JC, Wang YJ. Interstitial microwave antennas for thermal therapy. *Int J Hyperthermia*. 1987;3:37–47.
102. Lin JC, Wang YJ. An implantable microwave antenna for interstitial hyperthermia. *Proc IEEE*. 1987;75:1132–3.
103. Sullivan D. Mathematical methods for treatment planning in deep regional hyperthermia. *IEEE Trans Microw Theory Tech*. 1991;39:864–72.
104. Turner PF. Regional hyperthermia with an annular phased array. *IEEE Trans Biomed Eng*. 1984;31:106–14.
105. Seebass M, Beck R, Gellermann J, Nadobny J, Wust P. Electromagnetic phased arrays for regional hyperthermia-optimal frequency and antenna arrangement. *Int J Hyperthermia*. 2001;17:321–36.

106. Wust P, Fahling H, Wlodarczyk W, Seebass M, Gellermann J, Deuffhard P, Nadobny J. Antenna arrays in the SIGMA-eye applicator: interactions and transforming networks. *Med Phys*. 2001;28:1793–805.
107. Coit DG. Hyperthermic isolation limb perfusion for malignant melanoma: a review. *Cancer Invest*. 1992;10:277–84.
108. Ceelen WP, Hesse U, De Hemptinne B, Pattyn P. Hyperthermic intraperitoneal chemoperfusion in the treatment of locally advanced intra-abdominal cancer. *Br J Surg*. 2000;87:1006–15.
109. Ghussen F, Nagel K, Groth W, Muller JM, Stutzer H. A prospective randomized study of regional extremity perfusion in patients with malignant melanoma. *Ann Surg*. 1984;200:764–8.
110. Hafstrom L, Rudenstam CM, Blomquist E, Lindholm C, Ringborg U, Westman G, Ostmp. Regional hyperthermic perfusion with melphalan after surgery for recurrent malignant melanoma of the extremities. *J Clin Oncol*. 1991;9:2091–4.
111. Koops HS, Vaglini M, Suci S, Kroon BB, Thompson JF, Gohl J, Eggermont AM, Di Filippo F, Kremenz ET, Ruiten D, Lejeune FJ. Prophylactic isolated limb perfusion for localized, high-risk limb melanoma: results of a multicenter randomized phase III trial. *J Clin Oncol*. 1998;16:2906–12.
112. Anscher MS, Samulski TV, Dodge R, Prosnitz LR, Dewhirst MW. Combined external beam irradiation and external regional hyperthermia for locally advanced adenocarcinoma of the prostate. *Int J Radiat Oncol Biol Phys*. 1997;37:1059–65.
113. Coley WB. The treatment of malignant tumors by repeated inoculations of erysipelas: with a report of ten original cases. *Am J Med Sci*. 1893;33:195–9.
114. Xi L, Tekin P, Phargava P, Kukreja RC. Whole body hyperthermia and preconditioning of the heart: basic concepts, complexity, and potential mechanisms. *Int J Hyperthermia*. 2001;17:439–55.
115. Millian AJ. Whole-body hyperthermia induction techniques. *Cancer Res*. 1984;44(Suppl): 4869s–72s.
116. Storm FK. Clinical hyperthermia and chemotherapy. *Radiol Clin North Am*. 1989;27:621–7.
117. Robins HI, Hugander A, Cohen JD. Whole body hyperthermia in the treatment of neoplastic disease. *Radiol Clin North Am*. 1989;27:603–10.
118. Pettigrew RT, Galt JM, Ludgate CM, Horn DN, Smith AN. Circulatory and biochemical effects of whole body hyperthermia. *Br J Med*. 1974;61:727–30.
119. Pomp H. Clinical application of hyperthermia in gynecological malignant tumors. In: Strefer C, editor. *Cancer therapy by hyperthermia and radiation*. Baltimore: Urban and Schwarzenberg; 1978. p. 326–7.
120. Bull JM, Lees D, Schuette W, Whang-Peng J, Smith R, Bynum G, Atkinson ER, Gottdiener JS, Gralnick HR, Shawker TH, DeVita VT, Jr. Whole body hyperthermia: a phase I trial of a potential adjuvant to chemotherapy. *Ann Intern Med*. 1979;90:317–23.

121. Liebergall M, Simkin A, Mendelson S, Rosenthal A, Amir G, Segal D. Effect of moderate bone hyperthermia on cell viability and mechanical function. *Clin Orthop Relat Res.* 1998;349:242–8.
122. Gerke P, Filejski W, Robins HI, Wiedemann GJ, Steinhoff J. Nephrotoxicity of ifosfamide, carboplatin and etoposide (ICE) alone or combined with extracorporeal or radiant-heat-induced whole-body hyperthermia. *J Cancer Res Clin Oncol.* 2000; 126:173–7.
123. Bull JCM. Clinical practice of whole-body hyperthermia: new directions. In Seegenschmiedt MH, Fessenden P, Vernon CC, Editors. *Thermoradiotherapy and thermochemotherapy.* Vol 2. Berlin: Springer-Verlag; 1996. 303–22.
124. Szasz A, Vincze GY, Szasz O, Szasz N. An energy analysis of extracellular hyperthermia. *Electromag Biol Med.* 2003;22:103–15.
125. Kotnik T, Miklavcic D. Theoretical evaluation of the distributed power dissipation in biological cells exposed to electric field. *Bioelectromagnetics* 2000;21:385–94.
126. Vrba J. Medical applications of microwaves. *Electromagn Biol Med.* 2005;24: 441–8.
127. Hynynen K, Shimm D, Anhalt D, Stea B, Sykes H, Cassady JR, Roemer RB. Temperature distributions during clinical scanned, focused ultrasound hyperthermia treatments. *Int J Hyperthermia.* 1990;6:891–908.
128. Singh AK, Moros EG, Novak P, Straube W, Zeug A, Locke JE, Myerson RJ. MicroPET-compatible, small animal hyperthermia ultrasound system (SAHUS) for sustainable, collimated and controlled hyperthermia of subcutaneously implanted tumours. *Int J Hyperthermia.* 2004;20:32–44.
129. Lindsley K, Stauffer PR, Sneed P, Chin R, Phillips TL, Seppi E, Shapiro E, Henderson S. Heating patterns of the Helios ultrasound hyperthermia system. *Int J Hyperthermia.* 1993;9:675–84.
130. Lu XQ, Burdette EC, Bornstein BA, Hansen JL, Svensson GK. Design of an ultrasonic therapy system for breast cancer treatment. *Int J Hyperthermia.* 1996;12:375–99.
131. Lee RJ, Buchanan M, Kleine LJ, Hynynen K. Arrays of multielement ultrasound applicators for interstitial hyperthermia. *IEEE Trans Biomed Eng.* 1999;46:880–90.
132. Lee RJ, Suh H. Design and characterization of an intracavitary ultrasound hyperthermia applicator for recurrent or residual lesions in the vaginal cuff. *Int J Hyperthermia.* 2003;19:563–74.
133. Sekins KM, Leeper DB, Hoffman JK, Keilman GW, Ziskin MC, Wolfson MR, Shaffer TH. Feasibility of lung cancer hyperthermia using breathable perfluorochemical (PFC) liquids. Part II: Ultrasound hyperthermia. *Int J Hyperthermia.* 2004;20:278–99.
134. Beer E. Removal of neoplasms of the urinary bladder: a new method employing high frequency (oudin) currents through a cauterizing cystoscope. *JAMA.* 1910;54:1768–9.

135. Clark WL. Oscillatory desiccation in the treatment of accessible malignant growths and minor surgical conditions. *J Adv Therap.* 1911;29:169–83.
136. Clark WL, Morgan JD, Asnia EJ. Electrothermic methods in treatment of neoplasms and other lesions with clinical and histological observations. *Radiology.* 1924;2:233–46.
137. Fenn AJ, Diederich CJ, Stauffer PR. An adaptive-focussing algorithm for a microwave planar phased-array hyperthermia system. *Lincoln Lab J.* 1993;6:269–88.
138. Organ LW. Electrophysiologic principles of radiofrequency lesion making. *Appl Neurophysiol.* 1976-1977;39:69–76.
139. Sackenheim MM. Radio frequency ablation: the key to cancer treatment. *J Diagn Med Sonogr.* 2003;19:88–92.
140. Rhim, H, Goldberg SN, Dodd GD, Solbiati L, Lim HK, Tonolini M, Cho OK. Essential techniques for successful radio-frequency thermal ablation of malignant hepatic tumors. *Radiographics.* 2001;21:S17–S35.
141. Wittkamp FHM, Hauer RNW, Roblesde Medina EO. Control of RF lesions size by power regulation. *Circulation.* 1989;80:962–8.
142. Blouin LT, Marcus FI. The effect of electrode design on the efficiency of delivery of RF energy to cardiac tissue in vitro. *PACE.* 1989;12:136–43.
143. Reddy NM, Maithreyan V, Vasanthan A, Balakrishnan IS, Bhaskar BK, Jayaraman R, Shanta V, Krishnamurthi S. Local RF capacitive hyperthermia: thermal profiles and tumour response. *Int J Hyperthermia.* 1987;3:379–87.
144. Hiraoka M. Radiofrequency capacitive hyperthermia for deep-seated tumors. I. Studies on thermometry. *Cancer.* 1987;60:121–7.
145. Nussbaum GH, Sidi J, Rouhanizadeh N, Morel P, Jasmin C, Gonvert , Mabire JB, Azam G. Manipulation of central axis heating patterns with a prototype, three-electrode capacitive device for deep-tumor hyperthermia. *IEEE Trans Microw Theory Tech.* 1986;34:620–5.
146. Kato H, Hiraoka M, Nakajima T, Ishida T. Deep-heating characteristics of an RF capacitive heating device. *Int J Hyperthermia.* 1985;1:15–28.
147. Song CW, Rhee JG, Lee CK, Levitt SH. Capacitive heating of phantom and human tumors with an 8 MHz radiofrequency applicator (Thermotron RF-8). *Int J Radiat Oncol Biol Phys* 1986;12:365–72.
148. Kakehi M, Ueda K, Mukojima T, Hiraoka M, Seto O, Akanuma A, Nakatsugawa S. Multi-institutional clinical studies on hyperthermia combined with radiotherapy or chemotherapy in advanced cancer of deep-seated organs. *Int J Hyperthermia.* 1990;6:719–40.
149. Orcutt N, Gandhi OP. Use of the impedance method to calculate 3-D power deposition patterns for hyperthermia with capacitive plate electrodes. *IEEE Trans Biomed Eng.* 1990;37:36–43.
150. Nishimura Y, Hiraoka M, Akuta K, Jo S, Nagata Y, Masunaga S, Takahashi M, Abe M. Hyperthermia combined with radiation therapy for primarily unresectable and recurrent colorectal cancer. *Int J Radiat Oncol Biol Phys.* 1992;23:759–68.

151. Takeshita N, Tanaka Y, Matsuda T. Thermoradiotherapy for adenocarcinoma of the rectum and sigmoid—application to primarily inoperable and recurrent cases. *Nippon Igaku Hoshasen Gakkai Zasshi*. 1992;52:472–82.
152. Brown SL, Hill RP, Heinzl L, Hunt JW. Radiofrequency capacitive heaters: the effect of coupling medium resistivity on power absorption along a mouse leg. *Phys Med Biol*. 1993;38:1–12.
153. Karasawa K, Muta N, Nakagawa K, Hasezawa K, Terahara A, Onogi Y, Sakata K, Aoki Y, Sasaki Y, Akanuma A. Thermoradiotherapy in the treatment of locally advanced nonsmall cell lung cancer. *Int J Radiat Oncol Biol Phys*. 1994;30:1171–7.
154. Imada H, Nomoto S, Tomimatsu A, Kosaka K, Kusano S, Ostapenko VV, Terashima H. Local control of non small cell lung cancer by radiotherapy combined with high power hyperthermia using an 8 MHz RF capacitive heating device. *Jpn J Hyperthermic Oncol*. 1999;15:15–9.
155. Kuroda S, Uchida N, Sugimura K, Kato H. Thermal distribution of radio-frequency inductive hyperthermia using an inductive aperture-type applicator: evaluation of the effect of tumour size and depth. *Med Biol Eng Comput*. 1999;37:285–90.
156. Kroeze H, Van de Kamer JB, De Leeuw AAC, Kikuchi M, Lagendijk JJW. Treatment planning for capacitive regional hyperthermia. *Int J Hyperthermia*. 2003;19:58–73.
157. Ohguri T, Imada H, Yahara K, Kakeda S, Tomimatsu A, Kato F, Nomoto S, Terashima H, Korogi Y. Effect of 8-MHz radiofrequency-capacitive regional hyperthermia with strong superficial cooling for unresectable or recurrent colorectal cancer. *Int J Hyperthermia*. 2004;20:465–75.
158. Ohguri T, Imada H, Kato F, Yahara T, Morioka T, Kakano K, Korogi Y. Radiotherapy with 8 MHz radiofrequency-capacitive regional hyperthermia for pain relief of unresectable and recurrent colorectal cancer. *Int J Hyperthermia*. 2006;22:1–14.
159. Storm FK, Elliot RS, Harrison WH, Morton DL. Clinical RF hyperthermia by magnetic-loop induction: a new approach to human cancer therapy. *IEEE Trans Microw Theory Tech*. 1982;30:1124–58.
160. Kato H, Ishida T. A new inductive applicator for hyperthermia. *J Microw Power*. 1983;18:331–5.
161. Kotsuka Y, Watanabe M, Hosoi M, Isono I, Izumi M. Development of inductive regional heating system for breast hyperthermia. *IEEE Trans Microw Theory Tech*. 2000;48:1807–14.
162. Minamimura T, Sato H, Kasaoka S, Saito T, Ishizawa S, Takemori S, Tazawa K, Tsukada K. Tumor regression by inductive hyperthermia combined with hepatic embolization using dextran magnetite-incorporated microspheres in rats. *Int J Oncol*. 2000;16:1153–8.
163. Trakic A, Liu F, Crozier S. Transient temperature rise in a mouse due to low-frequency regional hyperthermia. *Phys Med Biol*. 2006;51:1673–91.

164. Kato H, Hand JW, Prior MV, Furukawa M, Yamamoto O, Ishida T. Control of specific absorption rate distribution using capacitive electrodes and inductive aperture-type applicators: implications for radiofrequency hyperthermia. *IEEE Trans Biomed Eng.* 1991;38:644–7.
165. Perez CA, Nussbaum G, Emami B, VonGerichten D. Clinical results of irradiation combined with hyperthermia. *Cancer.* 1983;52:1597–603.
166. Paglione R, Sterzer F, Mendecki J, Friedenthal E, Botstein C. 27 MHz ridged waveguide applicators for localized hyperthermia treatment of deep-seated malignant tumors. *Microwave J.* 1981;24:71–80.
167. De Leeuw AA, Mooibroek J, Lagendijk JJ. Specific absorption rate by patient positioning in the “coaxial TEM” system: phantom investigation. *Int J Hyperthermia.* 1991;7:605–11.
168. Van Es CA, Wijrdeman HK, De Leeuw AAC, Mooibroek J, Lagendijk JJW, Battermann JJ. Regional hyperthermia of pelvic tumours using the Utrecht Coaxial TEM system: a feasibility study. *Int J Hyperthermia.* 1995;11:173–86.
169. Van Vulpen M, De Leeuw AA, Van De Kamer JB, Kroeze H, Boon TA, Warlam-Rodenhuis CC, Lagendijk JJ, Battermann JJ. Comparison of intra-luminal versus intra-tumoural temperature measurements in patients with locally advanced prostate cancer treated with the coaxial TEM system: report of a feasibility study. *Int J Hyperthermia.* 2003;19:481–97.
170. Gabriele P, Orecchia R, Tseroni V, Melano A, Fillini C, Ragona R, Bolla L, Ogno G. Three new applicators for hyperthermia. *Arch Geschwulstforsch.* 1989;59:271–5.
171. Montecchia F. Microstrip-antenna design for hyperthermia treatment of superficial tumors. *IEEE Trans Biomed Eng* 1992;39:580–8.
172. Stauffer PR, Rossetto F, Leencini M, Gentili GB. Radiation patterns of dual concentric conductor microstrip antennas for superficial hyperthermia. *IEEE Trans Biomed Eng.* 1998;45:605–13.
173. Gelvich EA, Klimanov VA, Kramer-Ageev EA, Mazokhin VN. Computational evaluation of changes in ionizing radiation dose distribution in tissue caused by EM applicators when external radiation and hyperthermia act simultaneously. *Int J Hyperthermia.* 2006;22:343–52.
174. Nikawa Y, Kikuchi M, Mori S. Development and testing of a 2450 MHz lens applicator for localized microwave hyperthermia. *IEEE Trans Microw Theory Tech.* 1985;33:1212–6.
175. Croghan MK, Shimm DS, Hynynen KH, Anhalt DP, Valencic SL, Fletcher AM, Kittleson JM, Cetas TC. A phase I study of the toxicity of regional hyperthermia with systemic warming. *Am J Clin Oncol.* 1993;16:354–58.
176. Vrba J, Lapes M, Oppl L. Technical aspects of microwave thermotherapy. *Bioelectrochem Bioenerg.* 1999;48:305–9.

177. Guy AW. Electromagnetic fields and relative heating patterns due to a rectangular aperture source in direct contact with bilayered biological tissue. *IEEE Trans Microw Theory Tech.* 1971;19:214–23.
178. Antolini R, Cerri G, Cristoforetti L, De Leo R. Absorbed power distributions from single or multiple waveguide applicators during microwaved hyperthermia. *Phys Med Biol.* 1986;31:1005–19.
179. Nikita KS, Uzunoglu NK. Analysis of the power coupling from a waveguide hyperthermia applicator into a three-layered tissue model. *IEEE Trans Microw Theory Tech.* 1989;37:1794–800.
180. Andreuccetti D, Bini M, Ignesti A, Olmi R, Priori S, Vanni R. High permittivity patch radiator for single and multi-element hyperthermia applicators. *IEEE Trans Biomed Eng.* 1993;40:711–5.
181. Surowiec A, Bicher HI. Heating characteristics of the TRIPAS hyperthermia system for deep seated malignancy. *J Microw Power Electromagn Energy.* 1995;30:135–40.
182. Samaras T, Rietveld PJM, Rhoon GCV. Effectiveness of FDTD in predicting SAR distributions from the Lucite cone applicator. *IEEE Trans Microw Theory Tech.* 2000;48:2059–63.
183. Siauve N, Nicolas L, Vollaire C, Marchal C. Optimization of the sources in local hyperthermia using a combined finite element-genetic algorithm method. *Int J Hyperthermia.* 2004;20:815–33.
184. Gupta RC, Singh SP. Analysis of the SAR distributions in three-layered bio-media in direct contact with a water-loaded modified box-horn applicator. *IEEE Trans Microw Theory Tech.* 2005;53:2665–71.
185. Gupta RC, Singh SP. Development and analysis of a microwave direct contact water-loaded box-horn applicator for therapeutic heating of bio-medium. *Prog Electromag Res.* 2006;62, 217–35.
186. Fenn AJ, Sathiaseelan V, King G, Stauffer PR. Improved localization of energy deposition in adaptive phased-array hyperthermia treatment of cancer. *Lincoln Lab J.* 1996;9:187–96.
187. Manning MR, Cetas TC, Miller RC, Oleson JR, Connor WG, Gerner EW. Clinical hyperthermia results of a phase I trial employinh hyperthermia alone or in combination with external beam or interstitial radiotherapy. *Cancer.* 1982;49:205–16.
188. Strohbehn JW. Temperature distribution from RF electrode hyperthermia system: theoretical predictions. *Int J Radiat Oncol Biol Phys.* 1986;12:293.
189. Stauffer PR, Sneed PK, Suen SA, Satoh T, Matsumoto K, Fike JR, Phillips TL. Comparative thermal dosimetry of interstitial microwave and radiofrequency-LCF hyperthermia. *Int J Hyperthermia.* 1989;5:307–18.
190. Leybovich LB, Dogan N, Sethi A. A modified technique for RF-LCF interstitial hyperthermia. *Int J Hyperthermia.* 2000;16:405–13.

191. Fenn AJ, Wolf GL, Fogle RM. An adaptive microwave phased array for targeted heating of deep tumours in intact breast: animal study results. *Int J Hyperthermia* 1999;15:45–61.
192. Kowalski ME, Jin JM. Model-order reduction of nonlinear models of electromagnetic phased-array hyperthermia. *IEEE Trans Biomed Eng.* 2003a;50:1243–54.
193. Kowalski ME, Jin JM. A temperature-based feedback control system for electromagnetic phased-array hyperthermia: theory and simulation. *Phys Med Biol.* 2003;48:633–51.
194. Ocheltree KB, Benkeser PJ, Frizzell LA, Charles AC. An ultrasound phased array applicator for hyperthermia. *IEEE Trans Sonics Ultrasonics.* 1984;SU-31:526–31.
195. Cain CA, Umemura S. Concentric-ring and sector-vortex phased-array applicators for ultrasound hyperthermia. *IEEE Trans Microw Theory Tech.* 1986;34:542–51.
196. Benkeser BJ, Frizzell LA, Ocheltree KB, Cain CA. A tapered phased array ultrasound transducer for hyperthermia treatment. *IEEE Trans Ultras Ferro Freq Control.* 1987;34:446–53.
197. Ebbini ES, Umemura SI, Ibbini M, Cain CA. A cylindrical-section ultrasound phased-array applicator for hyperthermia cancer therapy. *IEEE Trans on Ultrasonics.* 1988;35:561–72.
198. Diederich CJ, Hynynen K. Induction of hyperthermia using an intracavitary multielement ultrasonic applicator. *IEEE Trans Biomed Eng.* 1989;36:432–8.
199. Diederich, CJ, Hynynen K. The feasibility of using electrically focused ultrasound arrays to induce deep hyperthermia via body cavities. *IEEE Trans Ultras Ferro Freq Control.* 1991;38:207–19.
200. Quan KM, Shiran M, Watmough DJ. Applicators for generating ultrasound-induced hyperthermia in neoplastic tumours and for use in ultrasound physiotherapy. *Phys Med Biol.* 1989;34:1719–31.
201. Daum DR, Buchanan MT, Fjield T, Hynynen K. Design and evaluation of a feedback based phased array system for ultrasound surgery. *IEEE Trans Ultras Ferro Freq Control.* 1998;45:431–8.
202. Ibbini MS, Cain CA. The concentric-ring array for ultrasound hyperthermia: combined mechanical and electrical scanning. *Int J Hyperthermia* 1990;6:401–19.
203. McGough RJ, Kessler ML, Ebbini ES, Cain CA. Treatment planning for hyperthermia with ultrasound phased arrays. *IEEE Trans Ultrasonics, Ferro Freq Control.* 1996;43:1074–84.
204. Daum DR, Hynynen K. A 256-element ultrasonic phased array system for the treatment of large volumes of deep seated tissue. *IEEE Trans Ultras Ferro Freq Control.* 1999;46:1254–68.
205. Smith NB, Merilees NK, Hynynen K, Dahleh M. Control system for an MRI compatible intracavitary ultrasound array for thermal treatment of prostate disease. *Int J Hyperthermia.* 2001;17:271–82.

206. Hynynen K, Pomeroy O, Smith DN, Huber PE, McDonnald NJ, Kettenbach J, Baum J, Singer S, Jolesz FA. MR imaging-guided focused ultrasound surgery of fibroadenomas in the breast: a feasibility study. *Radiology*. 2001;219:176–85.
207. Ju K-C, Chen Y-Y, Lin W-L, Kuo T-S. One-dimensional phased array with mechanical motion for conformal ultrasound hyperthermia. *Phys Med Biol*. 2003;48:167–82.
208. Connor CW, Hynynen K. Patterns of thermal deposition in the skull during transcranial focused ultrasound surgery. *IEEE Trans Biomed Eng*. 2004;51:1693–706.
209. Hand JW. Development of array applicators for superficial hyperthermia. *Int J Hyperthermia*. 1991;7:209–10.
210. Francomi C, Raganella L, Tiberio CA, Begnozzi L. Low-frequency RF hyperthermia. IV. A 27 MHz hybrid applicator for localized deep tumor heating. *IEEE Trans Biomedical Eng*. 1991;38:287–93.
211. Zhang Y, Joines WT, Jirtle RL, Samulski TV. Theoretical and measured electric field distribution within an annular phased array: consideration of source antennas. *IEEE Trans Biomed Eng*. 1993;40:780–7.
212. Gopal MK, Cetas TC. Current sheet applicators for clinical microwave hyperthermia. *IEEE Trans Microw Theory Tech*. 1993;41:431–7.
213. Wust P, Seebass M, Nadobny J, Deuflhard P, Monich G, Felix R. Simulation studies promote technological development of radiofrequency phased array hyperthermia. *Int J Hyperthermia*. 1996;12:477–94.
214. Wiersma J, Van Dijk JD. RF hyperthermia array modelling; validation by means of measured EM-field distributions. *Int J Hyperthermia*. 2001; 17:63–81.
215. Nadobny J, Wlodarczyk W, Westhoff L, Gellermann J. Development and evaluation of a three-dimensional hyperthermia applicator with water-coated antennas (WACOA). *Med Phys*. 2003; 30:2052–64.
216. Wu L, McGough RJ, Arabe OA, Samulski TV. An RF phased array applicator designed for hyperthermia breast cancer treatments. *Phys Med Biol*. 2006;51:1–20.
217. Rappaport CM, Morgenthaler FR. Localized hyperthermia with electromagnetic arrays and the leaky-wave troughguide applicator. *IEEE Trans Microw Theory Tech*. 1986;34:636–43.
218. Nikawa Y, Katsumata T, Kikuchi M, Mori S. An electric field converging applicator with heating pattern controller for microwave hyperthermia. *IEEE Trans Microw Theory Tech*. 1986;34:631–5.
219. Jouvie F, Bolomey J-C, Gaboriaud G. Discussion of capabilities of microwave phased arrays for hyperthermia treatment of neck tumors. *IEEE Trans Microw Theory Tech*. 1986;34:495–501.
220. Loane J, Ling H, Wang BF, Lee SW. Experimental investigation of a retro-focusing microwave hyperthermia applicator: conjugate-field matching scheme. *IEEE Trans on Microwave Theory Tech*. 1986;43:490–4.

221. Zhang Y, Joines WT, Oleson JR. Heating patterns generated by phase modulation of a hexagonal array of interstitial antennas. *IEEE Trans on Biomed Eng.* 1991;38:92–7.
222. Diederich CJ, Stauffer PR. Preclinical evaluation of a microwave array applicator for superficial hyperthermia. *Int J Hyperthermia.* 1993;9:227–46.
223. Sherar MD, Clark H, Cooper B, Kumaradas J, Liu FF. A variable microwave array attenuator for use with single-element waveguide applicators. *Int J Hyperthermia.* 1994;10:723–31.
224. Stauffer PR, Leoncini M, Manfrini V, Diederich CJ, Bozzo, D. Dual concentric conductor radiator for microwave hyperthermia with improved field uniformity to periphery of aperture, *IEICE Trans Commun.* 1995;E78-B(6):826–35.
225. Reuter CE, Taflove A, Sathiseelan V, Picket-May M, Mittal BB. Unexpected physical phenomena indicated by FDTD modeling of the Sigma-60 deep hyperthermia applicator. *IEEE Trans Microw Theory Tech.* 1998;46:313–9.
226. Fenn AJ, Sathiseelan V, King GA, Stauffer PR. Improved localization of energy deposition in adaptive phased-array hyperthermia treatment of cancer. *J Oncol Man.* 1998;7:22–9.
227. Gavrilov LR, Hand JW, Hopewell JW, Fenn AJ. Pre-clinical evaluation of a two-channel microwave hyperthermia system with adaptive phase control in a large animal. *Int J Hyperthermia.* 1999;15:495–507.
228. Jacobsen S, Stauffer PR, Neuman D. Dual-mode antenna design for microwave heating and noninvasive thermometry of superficial tissue disease. *IEEE Trans Biomed Eng.* 2000;47:1500–9.
229. Rossetto F, Diederich CJ, Stauffer PR. Thermal and SAR characterization of dual concentric conductor array applicators for hyperthermia, a theoretical investigation. *Med Phys.* 2000;27:745–53.
230. Rossetto F, Stauffer PR. Theoretical characterization of dual concentric conductor microwave applicators for hyperthermia at 433 MHz. In *J Hyperthermia.* 2001;17:258–70.
231. Jacobsen S, Stauffer PR. Non-invasive temperature profile estimation in a lossy medium based on multi-band radiometric signals sensed by a microwave dual-purpose body-contacting Antenna. *Int J Hyperthermia.* 2002;18:86–103.
232. Carlier J, Thomy V, Camart J-C, Dubois L, Pribetich J. Modeling of planar applicators for microwave thermotherapy. *IEEE Trans Microw Theory Tech.* 2002;50:3036–42.
233. Gardner RA, Vargas HI, Block JB, Vogel CL, Fenn AJ, Kuehl GV, Doval M. Focused microwave phased array thermotherapy for primary breast cancer. *Ann Surgl Oncol.* 2002;9:326–32.
234. Kumaradas JC, Sherar MD. Optimization of a beam shaping bolus for superficial microwave hyperthermia waveguide applicators using a finite element method. *Phys Med Biol.* 2003;48:1–18.

235. Converse M, Bond EJ, Hagness SC, Van Veen BD. Ultrawide-band microwave spece-time beamforming of hyperthermia treatment of breast cancer: a computational feasibility study. *IEEE Trans Microw Theory Tech.* 2004;52:1876–89.
236. Jaehoon K, Rahmat-Samii Y. Implanted antennas inside a human body: simulations, designs, and characterizations. *IEEE Trans Microw Theory Tech.* 2004;52:1934–43.
237. Vargas HI, Dooley WC, Gardner RA, Gonzalez KD, Venegas R, Heywang-Kobrunner SH, Fenn AJ. Focused microwave phased array radiotherapy for ablation of early-stage breast cancer: results of thermal dose escalatio. *Ann Surg Oncol.* 2004;11:139–46.
238. Taschereau R, Stauffer PR, Hsu IC, Schlorff JL, Milligan AJ, Pouliot J. Radiation dosimetry of a conformal heat-brachytherapy applicator. *Technol Cancer Res Treat.* 2004;3:347–58.
239. Sangster AJ, Sinclair KI. Multimode degenerate mode cavity for microwave hyperthermia treatment. *IEE Proc Microw Antennas Propag.* 2006;153:75–82.
240. Petrovich Z, Langholz B, Gibbs FA, Sapozink MD, Kapp DS, Stewart RJ, Emami B, Oleson J, Senzer N, Slater J, Astrahan M. Regional hyperthermia for advanced tumors: a clinical study of 353 patients. *Int J Radiat Oncol Biol Phys.* 1989;16:601–7.
241. Doss JD, McCabe CW. A technique for localized heating in tissue: an adjunct to tumor therapy. *Ned Instrum.* 1976;10:16–21.
242. Lagendijk JJW. Hyperthermia treatment planning. *Phys Med Biol* 2000;45:R61–R76.
243. Van der Koijk JF, Crezee J, Van Leeuwen GMJ, Battermann JJ, Lagendijk JJW. Dose uniformity in MECS interstitial hyperthermia: the impact of longitudinal control in model anatomies. *Phys Med Biol.* 1996;41:429–44.
244. Diederich CJ. Ultrasound applicators with integrated catheter-cooling for interstitial hyperthermia: theory and preliminary experiments. *Int J Hyperthermia.* 1996;12:279–97.
245. Diederich CJ, Khalil IS, Stauffer PR, Sneed PK, Phillips TL. Direct-coupled interstitial ultrasound applicators for simultaneous thermobrachytherapy: a feasibility study. *Int J Hyperthermia.* 1996;12:401–19.
246. Diederich CJ, Nau WH, Stauffer PR. Ultrasound applicators for interstitial thermal coagulation. *IEEE Trans Ultras Ferro Freq Control.* 1999;46:1218–28.
247. Jarosz BJ, Kaytar D. Ultrasonic heating with waveguide interstitial applicator array. *IEEE Trans Instrum Measur.* 1998;47:703–7.
248. Nau WH, Diederich CJ, Burdette EC. Evaluation of multielement catheter-cooled interstitial ultrasound applicators for high-temperature thermal therapy. *Med Phys.* 2001;28:1525–34
249. Jarosz BJ, St James S. Integrated temperature sensor for determination of ultrasound interstitial applicator heating effects. *IEEE Trans Instrum Measur.* 2005;54:1171–4.

250. Deurloo IKK, Visser AG, Morawska M, van Geel CAJF, van Rhoon GC, Levendag PC. Application of a capacitive-coupling interstitial hyperthermia system at 27 MHz: study of different applicator configurations. *Phys Med Biol.* 1991;36:119–32.
251. Prior MV. A comparative study of RF-LCP and hot-source interstitial hyperthermia techniques. *Int J Hyperthermia.* 1991;7:131–40.
252. Prionas SD, Kapp DS. Quality assurance for interstitial radiofrequency-induced hyperthermia. In: Handl-Zeller L, Editor. *Interstitial hyperthermia.* Vienna: Springer-Verlag; 1992. p. 77–94.
253. Kaatee RSJP, Crezee J, Kanis AP, Lagendijk JJW, Levendag PC, Visser AG. Design of applicators for a 27 MHz multielectrode current source interstitial hyperthermia system; impedance matching and effective power. *Phys Med Biol.* 1997;42:1087–108.
254. DeBree J, Lagendijk JJ, Raaymakers BW, Bakker CJ, Hulshof MC, Koot RW, Hanlo PW, Struikmans H, Ramos LM, Battermann JJ. Treatment planning of brain implants using vascular information and a new template technique. *IEEE Trans Med Imaging.* 1998;17:729–36.
255. Crezee J, Kaatee RS, van der Koijk JF, Lagendijk JJ. Spatial steering with quadruple electrodes in 27 MHz capacitively coupled interstitial hyperthermia. *Int J Hyperthermia.* 1999;15:145–56.
256. Sathiaseelan V, Leybovich L, Emami B, Stauffer P, Straube W. Characteristics of improved microwave interstitial antennas for local hyperthermia. *Int J Radiat Oncol Biol Phys.* 1991;20:531–9.
257. Hurter W, Reinbold F, Lorenz WJ. A dipole antenna for interstitial microwave hyperthermia. *IEEE Trans Microw Theory Tech.* 1991;39:1048–54.
258. Schaller G, Erb J, Engelbrecht R. Field simulation of dipole antennas for interstitial microwave hyperthermia. *IEEE Trans Microw Theory Tech.* 1996;44:887–95.
259. Hamada L, Saito K, Yoshimura H, Ito K. Dielectric-loaded coaxial-slot antenna for interstitial microwave hyperthermia: longitudinal control of heating patterns. *Int J Hyperthermia.* 2000;16:219–29.
260. Camart JC, Desprez D, Prevost B, Sozanski JP, Chive M, Pribetich J. New 434MHz interstitial hyperthermia system monitored by microwave radiometry: theoretical and experimental results. *Int J Hyperthermia.* 2000;16:95–111.
261. Saito K, Yoshimura H, Ito K, Aoyagi Y, Horita H. Clinical trials of interstitial microwave hyperthermia by use of coaxial-slot antenna with two slots, *IEEE Trans Microw Theory Tech.* 2004;52:1987–91.
262. Satoh T, Stauffer PR. Implantable helical coil microwave antenna for interstitial hyperthermia. *Int J Hyperthermia.* 1988;4:497–512.
263. Iskander MF, Tumeh AM. Design optimization of interstitial antennas. *IEEE Trans Biomed Eng.* 1989;36:238–46.

264. Schreier K, Budihna M, Lesnicar H, Handl-Zeller L, Hand JW, Prior MV, Clegg ST, Brezovich IA. Preliminary studies of interstitial hyperthermia using hot water. *Int J Hyperthermia*. 1990;6:431–44.
265. Van Hillegersberg HR, Jzermans JNM. Interstitial laser coagulation for hepatic tumours. *Br J Surg*. 1999;86:1365–2168.
266. Ikeda H, Tanaka M, Marsuo R, Fukuda H, Yamada R, Yamamoto I. Development of a new heating needle for interstitial hyperthermia compatible with interstitial radiotherapy. *Radiat Med*. 2001;19:285–9.
267. Safarikova M, Safarik I. The application of magnetic techniques in biosciences. *Magn Electr*. 2001;10:223–52.
268. Miltenyi S, Muller W, Weichel W, Radbruch A. High gradient magnetic cell separation with MACS. *Cytometry*. 1990;11:231–8.
269. Radbruch A, Mechtold B, Thiel A, Miltenyi S, Pfluger E. High-gradient magnetic cell sorting. *Methods Cell Biol*. 1994;42:387–403.
270. Shinkai M, Yanase M, Honda H, Wakabayashi T, Yoshida J, Kobayashi T. Intracellular hyperthermia for cancer using magnetite cationic liposomes: in vitro study. *Jpn J Cancer Res*. 1996;87:1179–83.
271. Takegami K, Sano T, Wakabayashi H, Sonoda J, Yamazaki T, Morita S, Shibuya T, Uchida A. New ferromagnetic bone cement for local hyperthermia. *J Biomed Mater Res*. 1998;43:210–4.
272. Sato F, Jojo M, Matsuki H, Sato T, Sendoh M, Ishiyama K, Arai I. The operation of a magnetic micromachine for hyperthermia and its exothermic characteristic. *IEEE Trans Magn*. 2002;38:3362–4.
273. Ito A, Tanaka K, Kondo K, Shinkai M, Honda H, Matsumoto K, Saida T, Kobayashi T. Tumor regression by combined immunotherapy and hyperthermia using magnetic nanoparticles in an experimental subcutaneous murine melanoma. *Cancer Sci*. 2003;94:308.
274. Matsuoka F, Shinkai M, Honda H, Kubo T, Sugita T, Kobayashi T. Hyperthermia using magnetite cationic liposomes for hamster osteosarcoma. *Biomagn Res Technol* 2004;2:3.
275. Ohura K, Ikenaga M, Nakamura T, Yamamuro T, Ebisawa Y, Kokudo T, Kotoura Y, Oka M. A heat-generating bioactive glass-ceramic for hyperthermia. *J Appl Biomater*. 1991;2:153–9.
276. Oleson JR, Samulski TV, Leopold KA, Clegg ST, Dewhirst MW, Dodge RK, George SL. Sensitivity of hyperthermia trial outcomes to temperature and time: implications for thermal goals of treatment. *Int J Radiat Oncol Biol Phys*. 1993;25:289–97.
277. Prionas SD, Kapp DS, Goffinet DR, Ben-Yosef R, Fessenden P, Bagshaw MA. Thermometry of interstitial hyperthermia given as an adjuvant to brachytherapy for the treatment of carcinoma of the prostate. *Int J Radiat Oncol Biol Phys*. 1994;28:151–62.

278. Emami B, Scott C, Perez CA et al. Phase III study of interstitial thermoradiotherapy compared with interstitial radiotherapy alone in the treatment of recurrent or persistent human tumors. A prospectively controlled randomized study by the Radiation Therapy Group. *Int J Radiat Oncol Biol Phys.* 1996;34:1097–04.
279. Hand JW, Machin D, Vernon CC, Whaley JB. Analysis of thermal parameters obtained during phase III trials of hyperthermia as an adjunct to radiotherapy in the treatment of breast carcinoma. *Int J Hyperthermia.* 1997;13:343–64.
280. Wust P, Rau B, Gellerman J, Pegios W, Loffel J, Riess H, Felix R, Schlag PM. Radiochemotherapy and hyperthermia in the treatment of rectal cancer. *Recent Results Cancer Res.* 1998;146:175–91.
281. Konings AW. Interaction of heat and radiation in vitro and in vivo. In: Seegendchmiedt MH, Fessenden P, Vernon CC, editors. *Radiothermotherapy and thermochemotherapy.* Vol 1. New York: Springer; 1995. p. 89–102.
282. Takahashi I, Emi Y, Hasuda S, Kakeji Y, Maehara Y, Sugimachi K. Clinical application of hyperthermia combined with anticancer drugs for the treatment of solid tumors. *Surgery.* 2002;131:S78–S84.
283. Dahl O, Dalene R, Schem BC, Mella O. Status of clinical hyperthermia. *Acta Oncol.* 1999;38:863–73.
284. Song CWM, Shakil A, Griffin RJ, Okajima K. Improvement of tumor oxygenation status by mild temperature hyperthermia alone or in combination with carbogen. *Semin Oncol.* 1997;24:626–32.
285. Song CW, Shakil A, Osborn JL, Iwata K. Tumour oxygenation is increased by hyperthermia at mild temperatures. *Int J Hyperthermia.* 1996;12:367–73.
286. Rau B, Wust P, Tilly W, Gellermann J, Harder C, Riess H, Budach V, Felix R, Schlag PM. Preoperative radiochemotherapy in locally advanced or recurrent rectal cancer: regional radiofrequency hyperthermia correlates with clinical parameters. *Int J Radiat Oncol Biol Phys.* 2000;48:381–91.
287. Overgaard J. The current and potential role of hyperthermia in radiotherapy. *Int J Radiat Oncol Biol Phys.* 1989;16:535–49.
288. Kim JH, Hahn EW, Tokita N, Nisce LZ. Local tumor hyperthermia in combination with radiation therapy. 1. Malignant cutaneous lesions. *Cancer.* 1977;40:161–9.
289. Kim JH, Hahn EW, Benjamin FJ. Treatment of superficial cancers by combination hyperthermia and radiation therapy. *Clin Bull.* 1979;9:13–6.
290. Bicher HI, Sandhu TS, Hetzel FW. Hyperthermia as an adjuvant to radiation: proposal for an effective fractionation regime. *Int J Radiat Oncol Biol Phys.* 1980;6:867–70.
291. González González D, Van Dijk JDP, Blank LECM, Rümke PH. Combined treatment with radiation and hyperthermia in metastatic malignant melanoma. *Radiother Oncol.* 1986;6:105–13.
292. Van der Zee J, Treurniet-Donker AD, The SK et al. Low dose reirradiation in combination with hyperthermia: a palliative treatment for patients with breast cancer

- recurring in previously irradiated areas. *Int J Radiat Oncol Biol Phys.* 1988;15:1407–13.
293. Van der Zee, Peer-Valstar JN, Rietveld PJ, de Graaf-Strukowska L, Van Rhoon GC. Practical limitations of interstitial thermometry during deep hyperthermia. *Int J Radiat Oncol Biol Phys.* 1998;40:1205–12.
 294. Van der Zee J, Van der Holt B, Rietveld PJM, Hele PA, Wijnmaalen AJ, van Putten WL, van Rhoon GC. Reirradiation combined with hyperthermia in recurrent breast cancer results in a worthwhile local palliation. *Br J Cancer.* 1999;79:483–90.
 295. Van der Zee J, González, González D, Van Rhoon GC, Van Dijk JDP, Van Putten WLJ, Hart AAM. Comparison of radiotherapy alone with radiotherapy plus hyperthermia in locally advanced pelvic tumours: a prospective, randomised, multicentre trial. *Lancet.* 2000;355:1119–25.
 296. Hiraoka M, Masunaga S, Nishimura Y, Nagata Y, Jo S, Akuta K, Li YP, Takahashi M, Abe M. Regional hyperthermia combined with radiotherapy in the treatment of lung cancers. *Int J Radiat Oncol Biol Phys.* 1992;22:1009–14.
 297. Masunaga S, Hiraoka M, Akuta K. The phase I/II trial of preoperative thermotherapy in the treatment of urinary bladder cancer. *Int J Hyperthermia.* 1994;10:31–40.
 298. Overgaard J, Gonzalez Gonzalez D, Hulshof MC, Arcangeli G, Dahl O, Mella O, Bentzen SM. Hyperthermia as an adjuvant to radiation therapy of recurrent or metastatic malignant melanoma. A multicentre randomized trial by the European Society for Hyperthermic Oncology. *Int J Hyperthermia.* 1996;12:3–20.
 299. Van der Zee J, González González D. Radiotherapy and hyperthermia in inoperable pelvic tumours: Results of Dutch randomized studies. *Eur J Cancer.* 1997;33:S205–S6.
 300. Myerson RJ, Strauble WL, Moros EG, Emami BN, Lee HK, Perez CA, Taylor ME. Simultaneous superficial hyperthermia and external radiotherapy: report of thermal dosimetry and tolerance to treatment. *Int J Hyperthermia.* 1999;15:251–66.
 301. Amichetti M, Romano M, Cristoforetti L, Valdagni R. Hyperthermia and radiotherapy for inoperable squamous cell carcinoma metastatic to cervical lymph nodes from an unknown primary site. *Int J Hyperthermia.* 2000;16:85–93.
 302. Van der Zee J, González González D. The Dutch deep hyperthermia trial: results in cervical cancer. *Int J Hyperthermia.* 2002;18:1–12.
 303. Van der Zee J. Lessons learned from hyperthermia. *Int J Radiat Oncol Biol Phys.* 2003;57:596–7.
 304. Van Vulpen M., De Leeuw AAC, Raaymakers BW, Van Moorselaar RJA, Hofman P, Lagendijk JJW, Battermann JJ. Radiotherapy and hyperthermia in the treatment of patients with locally advanced prostate cancer: preliminary results. *BJU Int* 2004;93:36–41.
 305. Van Der Zee J, Van Rhoon GC. Cervical cancer: Radiotherapy and hyperthermia. *Int J Hyperthermia.* 2006;22:229–34.
 306. Vasanthan, A, Mitsumori, M, Park, JH, Zhi-Fan Z, Yu-Bin, Z, Oliynychenko, P, Tatsuzaki H, Tanaka Y, Hiraoka M. Regional hyperthermia combined with radio-

- therapy for uterine cervical cancers: A multi-institutional prospective randomized trial of the international atomic energy agency. *Int J Oncol Biol Phys.* 2005;61:145–53.
307. Takahashi M, Fujimoto S, Kobayashi K, Mutou T, Kure M, Masaoka H, Shimanskaya RB, Takai M, Endoh F, Ohkubo H. Clinical outcome of intraoperative pelvic hyperthermochemotherapy for patients with Dukes' C rectal cancer. *Int J Hyperthermia.* 1994;10:749–54.
 308. Skibba JL, Jones FE, Condon RE. Altered hepatic disposition of doxorubicin in the perfused rat liver at hyperthermic temperatures. *Cancer Treat Rep.* 1982;66:1357–63.
 309. Zimmer RP, Ecker HA, Popovic VP. Selective electromagnetic heating of tumors in animals in deep hypothermia. *IEEE Trans Microw Theory Tech.* 1971;19:232–8.
 310. Ghussen F, Krüger I, Smalley RV, Groth W. Hyperthermic perfusion with chemotherapy for melanoma of the extremities. *World J Surg.* 1989;13:598–602.
 311. Issels RD, Mittermüller J, Gerl A, Simon W, Ortmaier A, Denzlinger C, Sauer H, Wilmanns W. Improvement of local control by regional hyperthermia combined with systemic chemotherapy (ifosfamide plus etoposide) in advanced sarcomas: updated report on 65 patients. *J Cancer Res Clin Oncol.* 1991;117:S141–S7.
 312. Kondo M. Therapeutic effects of chemoembolization using degradable starch microspheres and regional hyperthermia on unresectable hepatocellular carcinoma. In: Matsuda T, Editor. *Cancer treatment by hyperthermia, radiation and drugs.* New York: Taylor & Francis; 1993. p. 317–27.
 313. Zaffaroni N, Fiorentini G, De Giorgi U. Hyperthermia and hypoxia: new developments in anticancer chemotherapy. *Eur J Surg Oncol.* 2001;27:340–2.
 314. Prosnitz L, Jones E. Counterpoint: Test the value of hyperthermia in patients with carcinoma of the cervix being treated with concurrent chemotherapy and radiation. *Int J Hyperthermia.* 2002;18:13–8.
 315. Sagowski C, Jaehne M, Kehrl W, Hegewisch-Becker S, Wenzel S, Panse J, Nierhaus A. Tumor oxygenation under combined whole-body-hyperthermia and polychemotherapy in a case of recurrent carcinoma of the oral cavity. *Eur Arch Otorhinolaryngol.* 2002;259:27–31.
 316. Morita K, Tanaka R, Kakinuma K, Takahashi H, Motoyama H. Combination therapy of rat brain tumours using localized interstitial hyperthermia and intra-arterial chemotherapy. *Int J Hyperthermia.* 2003;19:204–12.
 317. Mauz-Körholz C, Dietzsch S, Banning U, Tröbs RB, Körholz D. Heat- and 4-hydroperoxy-ifosfamide-induced apoptosis in B cell precursor leukaemias. *Int J Hyperthermia.* 2003;19:444–60.
 318. Hildebrandt B, Drager J, Kerner T, Deja M, Löffel J, Stroszczyński C, Ahlers O, Felix R, Riess H, Wust P. Whole-body hyperthermia in the scope of von Ardenne's systemic cancer multistep therapy (sCMT) combined with chemotherapy in patients with metastatic colorectal cancer: phase I/II study. *Int J Hyperthermia.* 2004;20:317–33.

319. Ismail-zade RS, Zhavrid EA, Potapnev MP. Whole body hyperthermia in adjuvant therapy of children with renal cell carcinoma. *Ped Blood Cancer*. 2005;44:679–81.
320. Kraybill WG, Olenki T, Evans SS, Ostberg JR, O'Leary KA, Gibbs JF, Repasky EA. A phase I study of fever-range whole body hyperthermia (FR-WBH) in patients with advanced solid tumors: correlation with mouse models. *Int J Hyperthermia*. 2002;19:253–66.
321. Hegewisch-Becker S, Gruber Y, Corovic A, Pichlmeier U, Atanackovic D, Nierhaus A, Hossfeld DK. Whole-body hyperthermia (41.8 degrees C) combined with bimonthly oxaliplatin, high-dose leucovorin and 5-fluorouracil 48-hour continuous infusion in pretreated metastatic colorectal cancer: a phase II study. *Ann Oncol*. 2002;13:1197–204.
322. Bakhshandeh A, Bruns I, Traynor A, Robins HI, Eberhardt K, Demedts A, Kaukel E, Koschel G, Gatzemeier U, Kohlmann Th, Dalhoff K, Ehlers EM, Gruber Y, Zumschlinge R, Hegewisch-Becker S, Peters SO, Wiedemann GJ. Ifosfomide, carboplatin, and etoposide combined with 41.8 degrees centigrade whole body hyperthermia for malignant pleural mesothelioma. *Lung Cancer*. 2003;39:339–45.
323. Hegewisch-Becker S, Braun K, Otte M, Corovic A, Atanackovic D, Nierhaus A, Hossfeld DK, Pantel K. Effects of whole body hyperthermia (41.8 degrees centigrade) on the frequency of tumor cells in the peripheral blood of patients with advanced malignancies. *Clin Cancer Res*. 2003;9:2079–84.
324. Richel O, Zum Vorde Sive Vording PJ, Rietbroek R, Van der Velden J, Van Dijk JD, Schilthuis MS, Westermann AM. Phase II study of carboplatin and whole body hyperthermia (WBH) in recurrent and metastatic cervical cancer. *Gynecol Oncol*. 2004;95:680–5.
325. Kai H, Matsufuji H, Okudaira Y, Sugimachi K. Heat, drugs and radiation given in combination is palliative for unresectable esophageal cancer. *Int J Radiat Oncol Biol Phys*. 1988;14:1147–52.
326. Kuwano H, Matsuura H, Mori M. Hyperthermia combined with chemotherapy and irradiation for the treatment of patients with carcinoma of the oesophagus and the rectum. In: Matsuda T, Editor. *Cancer treatment by hyperthermia, radiation and drugs*. New York: Taylor & Francis; 1993. p. 353–64.
327. Sakamoto T, Katoh H, Shimizu T, Yamashita I, Takemori S, Tazawa K, Fujimaki M. Clinical results of treatment of advanced esophageal carcinoma with hyperthermia in combination with chemoradiotherapy. *Chest*. 1997;112:1487–93.
328. Ohno S, Tomoda M, Tomisaki S, Kitamura K, Mori M, Maehara Y, Sugimachi K. Improved surgical results after combining preoperative hyperthermia with chemotherapy and radiotherapy for patients with carcinoma of the rectum. *Dis Colon Rectum*. 1997;40:401–6.
329. Rau B, Wust P, Hohenberger P, Loffel J, Hunerbein M, Below C, Gellermann J, Speidel A, Vogl T, Riess H, Felix R, Schlag PM. Preoperative hyperthermia combined with radiochemotherapy in locally advanced rectal cancer. A phase II clinical study. *Ann Surg*. 1998;227:380–9.

330. Sakurai H, Mitsunashi N, Tamaki Y, Akimoto T, Murata O, Kitamoto Y, Maebayashi K, Ishikawa H, Hayakawa K, Niibe H. Interaction between low dose-rate irradiation, mild hyperthermia and low-dose caffeine in a human lung cancer cell line. *Int J Rad Biol.* 1999;75:739–45.
331. Feyerabend T, Wiedemann GJ, Jäger B, Vesely H, Mahlmann B, Richter E. Local hyperthermia, radiation, and chemotherapy in recurrent breast cancer is feasible and effective except for inflammatory disease. *Int J Radiat Oncol Biol Phys.* 2001;49:1317–25.
332. Kouloulis V, Plataniotis G, Kouvaris J, Dardoufas C, Gennatas C, Uzunoglu N, Papavasiliou C, Vlahos L. Chemoradiotherapy combined with intracavitary hyperthermia for anal cancer: feasibility and long-term results from a phase II randomized trial. *Am J Clin Oncol.* 2005;28:91–9.
333. Song CW, Park HJ, Lee CK, Griffin R. Implications of increased tumor blood flow and oxygenation caused by mild temperature hyperthermia in tumor treatment. *Int J Hyperthermia.* 2005;21:761–7.
334. Gerner EW, Hersh EM, Pennington M, Tsang TC, Harris D, Vasawala F, Brailey J. Heat-inducible vectors for use in gene therapy. *Int J Hyperthermia.* 2000;16:171–81.
335. Huang Q, Hu JK, Lohr F, Zhang L, Braun R, Lanzen J, Little JB, Dewhirst MY, Li CY. Heat-induced gene expression as a novel targeted cancer gene therapy strategy. *Cancer Res.* 2000;60:3435–9.
336. Okamoto K, Shinoura N, Egawa N, Asai A, Kirino T, Shibasaki F, Shitara N. Adenovirus-mediated transfer of p53 augments hyperthermia-induced apoptosis in U251 glioma cells. *Int J Radiat Oncol Biol Phys.* 2001;50:525–31.
337. Lohr F, Hu K, Huang Q, Zhang L, Samulski TV, Dewhirst MW, Li CY. Enhancement of radiotherapy by hyperthermia-regulated gene therapy. *Int J Radiat Oncol Biol Phys.* 2000;48:1513–8.
338. Mattingly M, Bailey EA, Dutton AW, Roemer RB, Devasia S. Reduced-order modeling for hyperthermia: an extended balanced-realization-based approach. *IEEE Trans Biomed Eng.* 1997;45:1154–61.
339. Kapp DS, Cox R. Thermal treatment parameters are most predictive of outcome in patients with single tumor nodules per treatment field in recurrent adenocarcinoma of the breast. *Int J Radiat Oncol Biol Phys.* 1995;33:887–99.