



ESCOLA POLITÉCNICA DA UNIVERSIDADE DE SÃO PAULO

PMR 3501
Engenharia de Precisão

A21

**Transmissores, conversores,
amplificadores e acoplamento do
movimento – P1**

2020.2



Planejamento

Dia	S	Aula	Tópico	Prof.
08.10	5ª	A17	Elementos de máquinas de precisão – mancais e guias hidrostáticos	RS
14.10	4ª	A18	Elementos de máquinas de precisão – mancais e guias aerostáticos	RS
15.10	5ª	A19	Elementos de máquinas de precisão – mancais e guias de elementos rolantes	RS
21.10	4ª	A20	Elementos de máquinas de precisão – mancais não convencionais	RS
22.10	5ª	A21	Elementos de máquinas de precisão – transmissores do movimento	RS
28.10	4ª		Feriado	RS
29.10	5ª	A22	Elementos de máquinas de precisão – conversores do movimento	RS
04.11	4ª	A23	Elementos de máquinas de precisão – atuadores	RS
05.11	5ª	A24	Elementos de máquinas de precisão – acoplamentos	RS
11.11	4ª	A25	Exercícios -4	RS
12.11	5ª	A26	Estruturas de sistemas de precisão: Requisitos, Materiais e Fabricação	RS
18.11	4ª	A27	Estruturas de sistemas de precisão: configurações estruturais e laço estrutural	RS
19.11	5ª	A28	Estruturas de sistemas de precisão: considerações estáticas, dinâmicas e térmicas. Erros, propagação de erros / compensação de erros	RS
25.11	4ª	A29	Materiais para componentes de precisão	RS
26.11	5ª	A30	Exercícios -5	RS
02.12	4ª	A29	Apresentação de Estudo de Caso/Seminário	RS
03.12	5ª	A30	Apresentação de Estudo de Caso/Seminário	RS
09.12	4ª	A31		
10.12	5ª			
14.12	3ª		Encerramento do semestre 2020-2	
06.12			Medidor tridimensional de coordenadas	



Como transmitir o movimento para o carro?

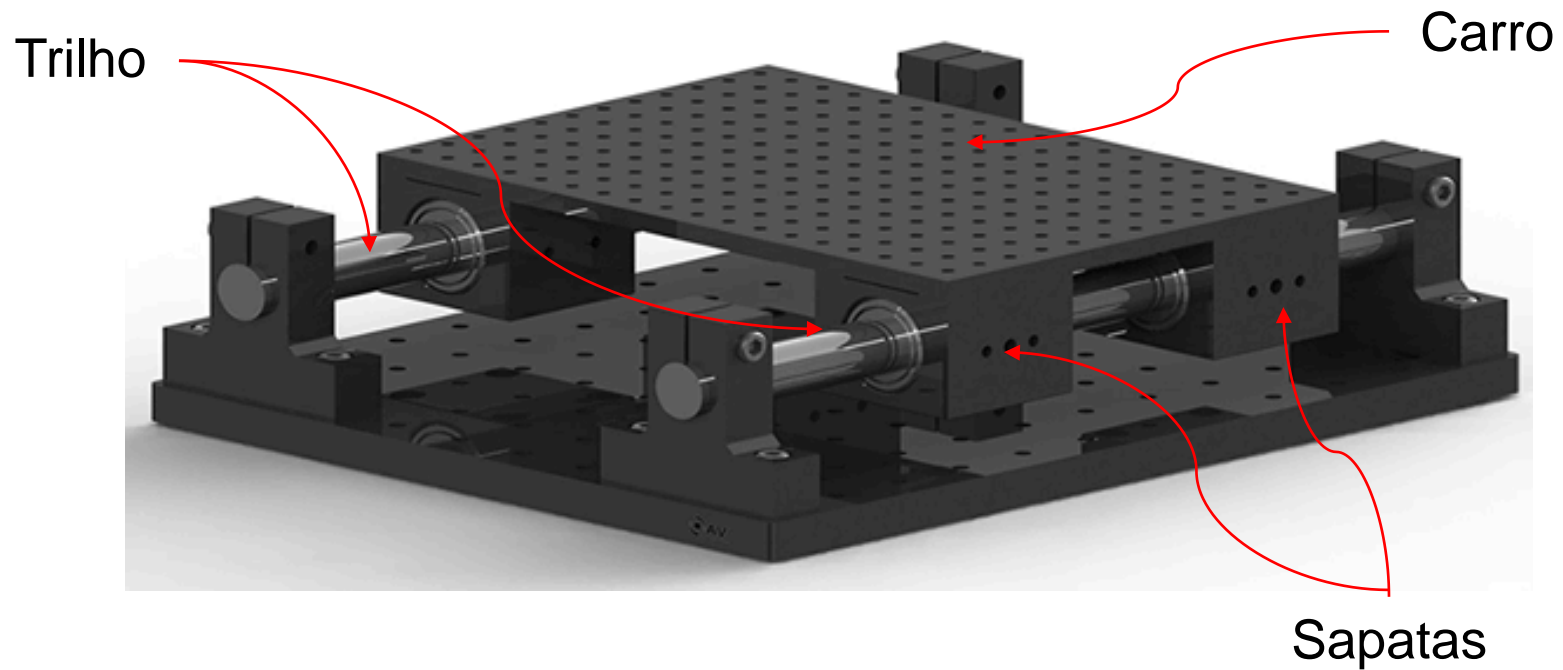



Como posicionar com precisão submicrométrica ?

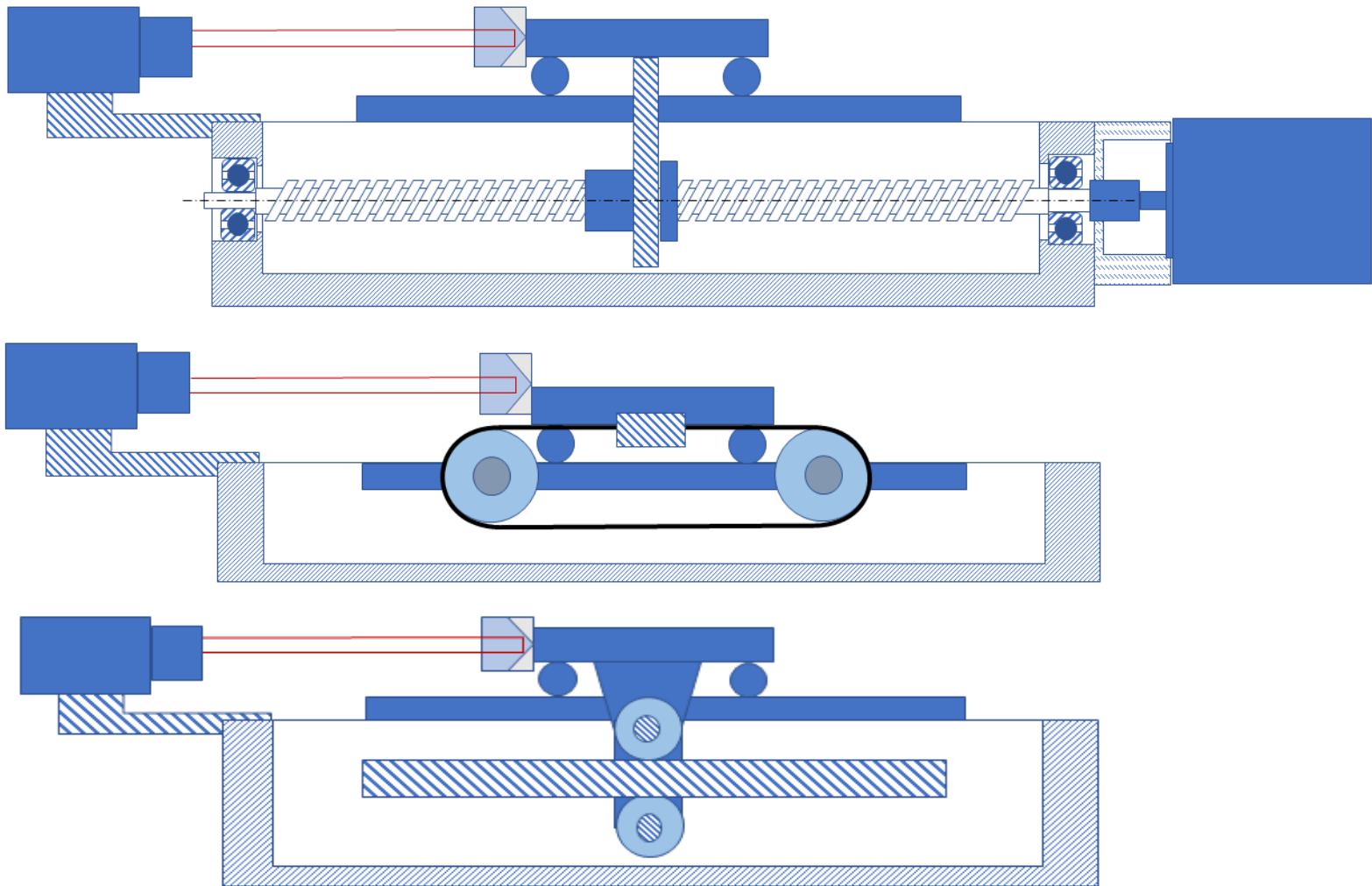



Conversores / Transmissores

Introdução

Existe uma série de soluções de projeto que permitem a conversão e a transmissão do movimento, desde sua fonte geradora até o ponto onde o movimento é desejado.

Sob alguns aspectos de projeto conversores e transmissores se confundem e aplicação.

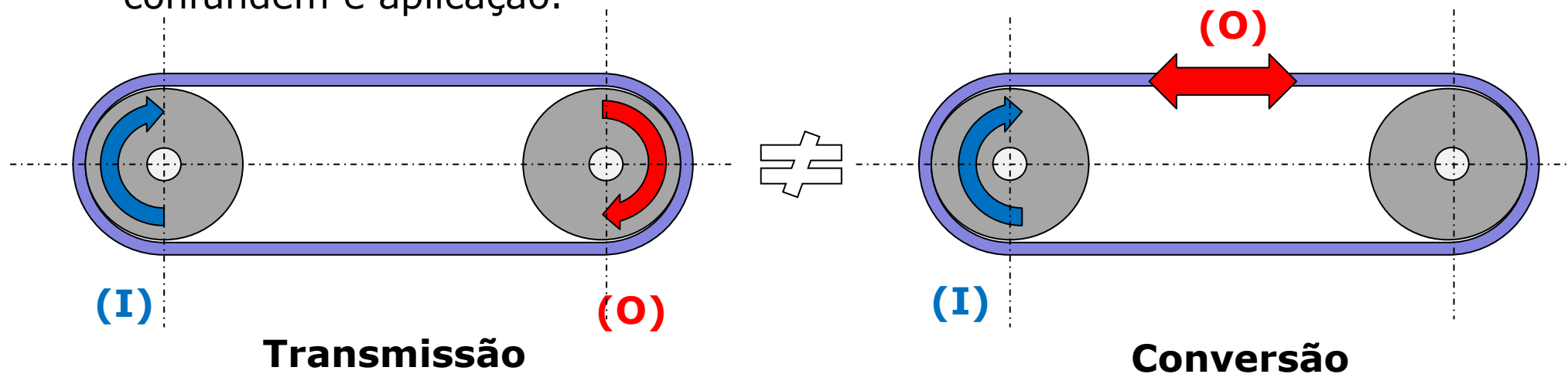

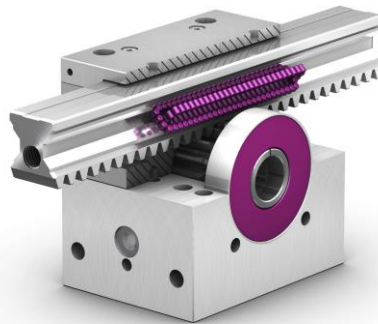



Engrenagens

Variações

Sem fim

trens

Polias

planetárias

harmônico

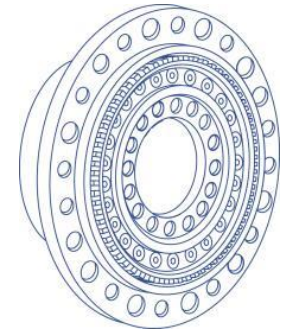
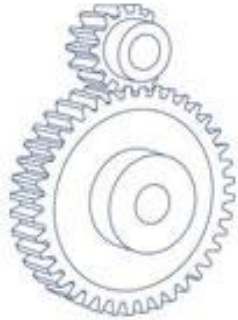

redutores



Engrenagens

Características



- Transmissão do movimento
- Direcionamento do movimento
- Amplificação / redução de velocidades
- Amplificação / redução de torque
- Forte dependência da qualidade das engrenagens (custo)
- Fontes de vibrações
- Sujeitas a desgaste
- Ajustagem (problema de Backlash)
- Erros acumulativos



Engrenagens

dimensionamento

- É o mesmo de elementos de máquinas clássico
- O cuidado é direcionado a fabricação

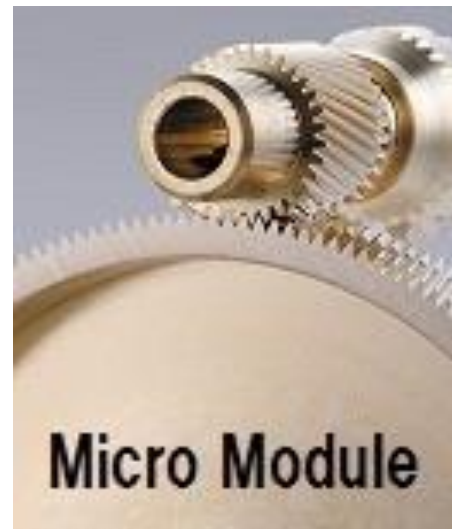



Engrenagens

Exemplos de aplicação



Pressure tolerant underwater drive with maxon motor and gearhead, EC-140 and GP42



Conversores / Transmissores

Cremalheiras

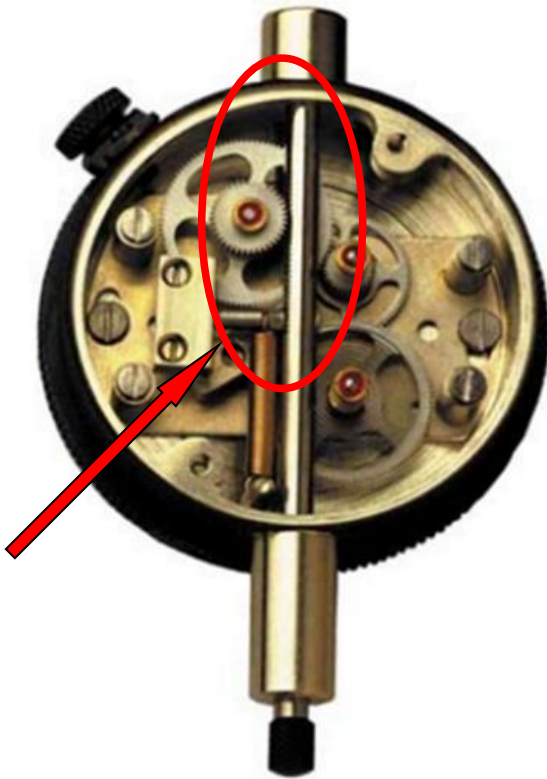

- Transmissão do movimento
- Conversão do movimento
- Amplificação / redução de velocidades
- Amplificação / redução de torque
- Forte dependência da precisão de fabricação
- Fontes de vibrações
- Sujeitas a desgaste
- Ajustagem (problema de Backlash)



Cremalheira

Eliminação das folgas

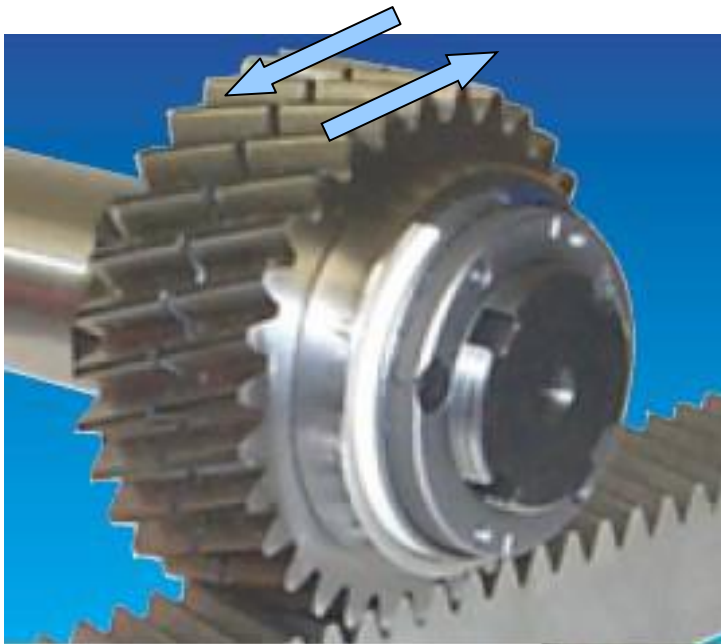

When stopped, the gear teeth are in contact

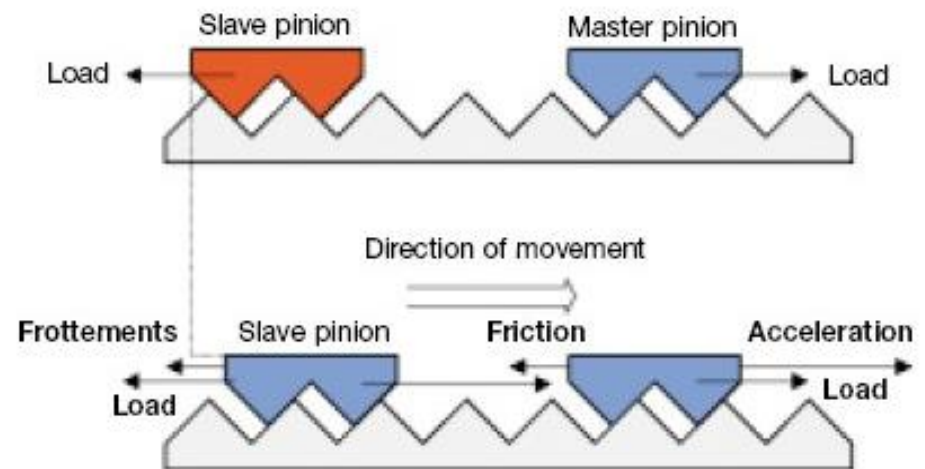

During acceleration, the slave pinion gear teeth cross the gap and come to rest against the opposite side.



Cremalheiras

dimensionamento

- É o mesmo de elementos de máquinas clássico
- O cuidado é direcionado a fabricação

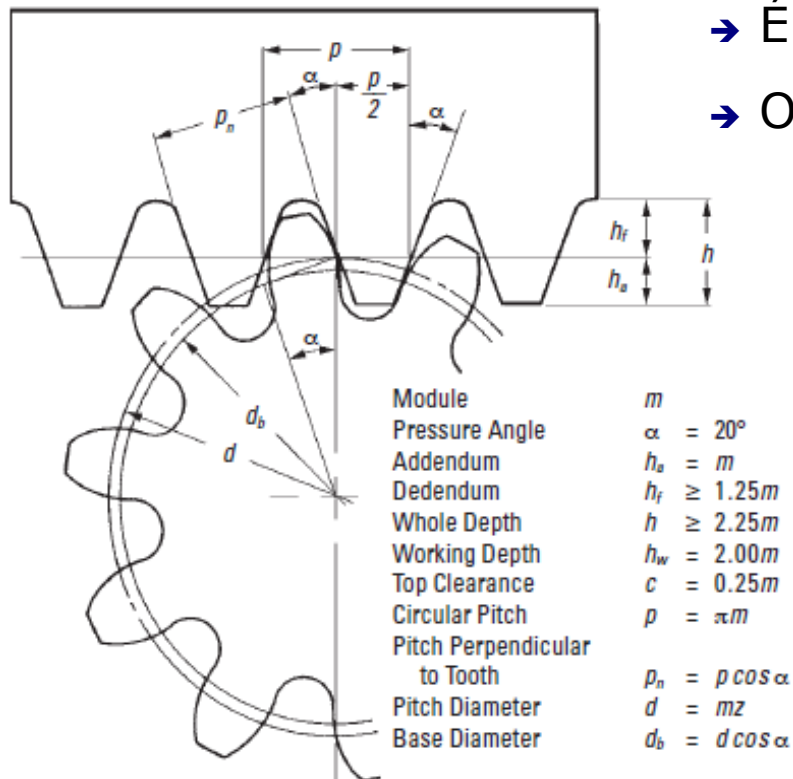

The Tooth Profile and Dimension of Standard Rack



Cremalheiras

Exemplo

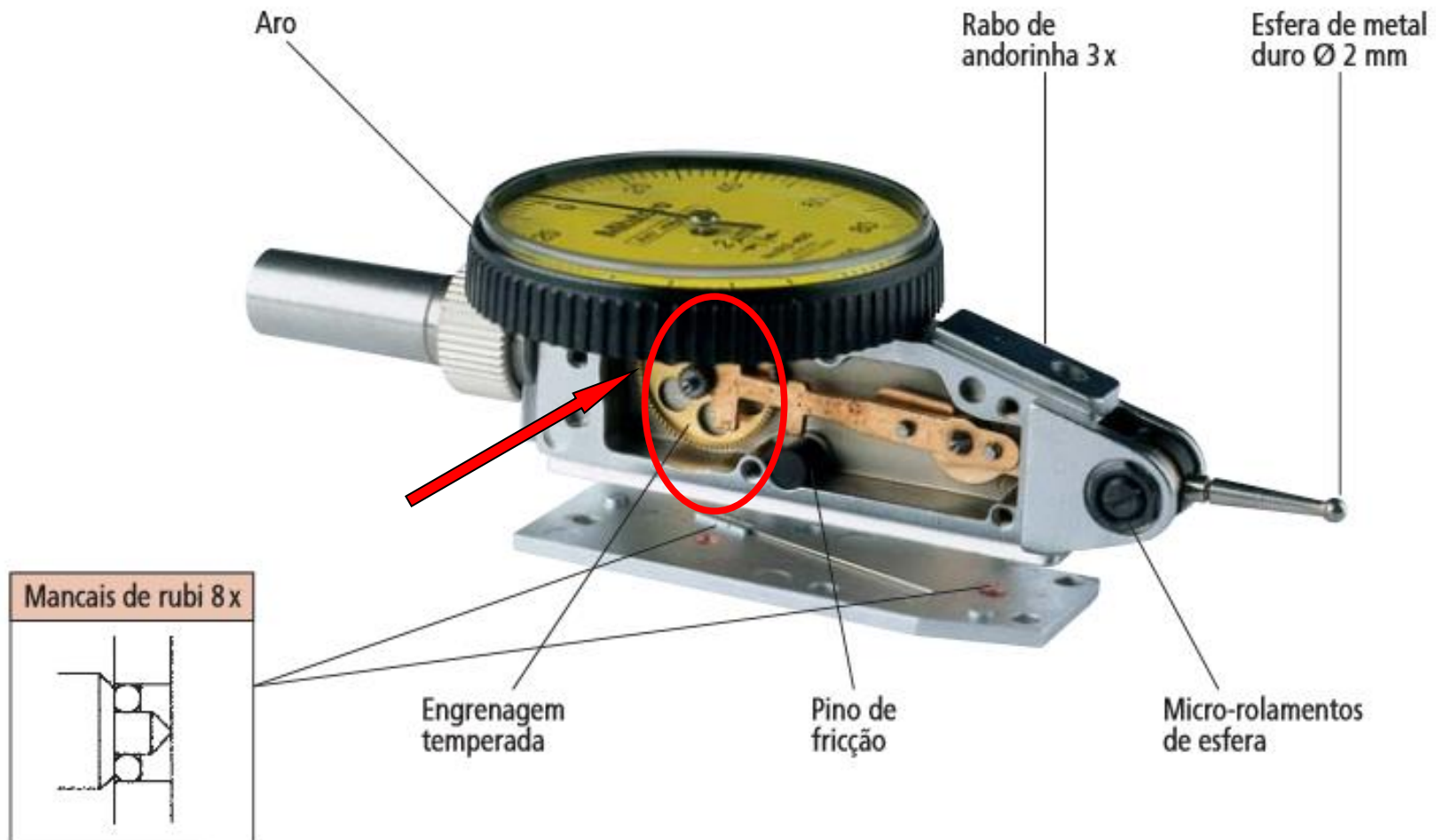



Cremalheiras

Exemplos

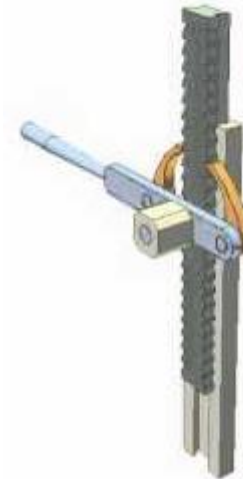
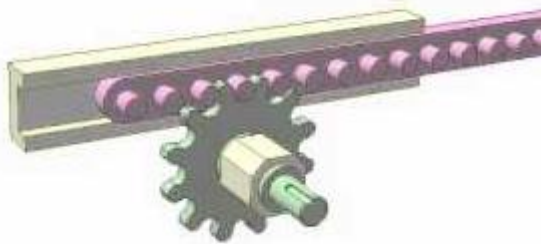
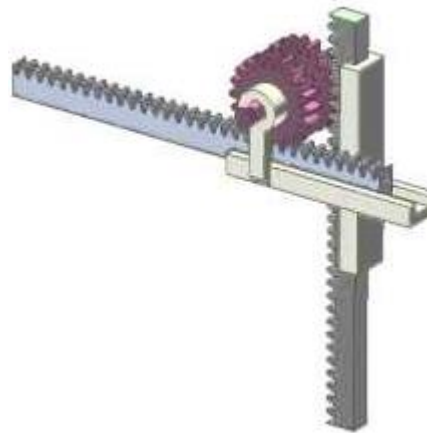
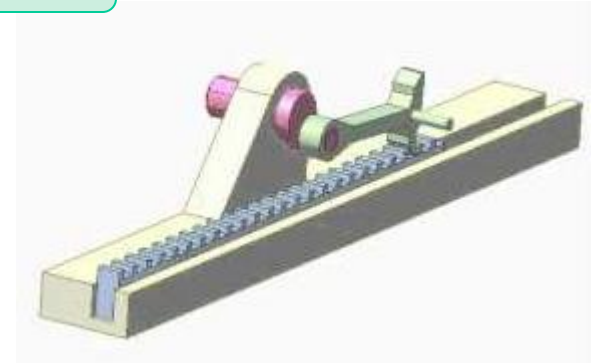
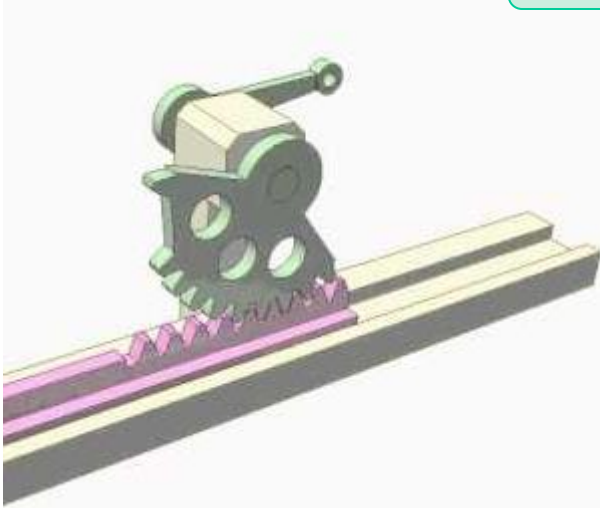



Transmissão combinada

Engrenagens cremalheira

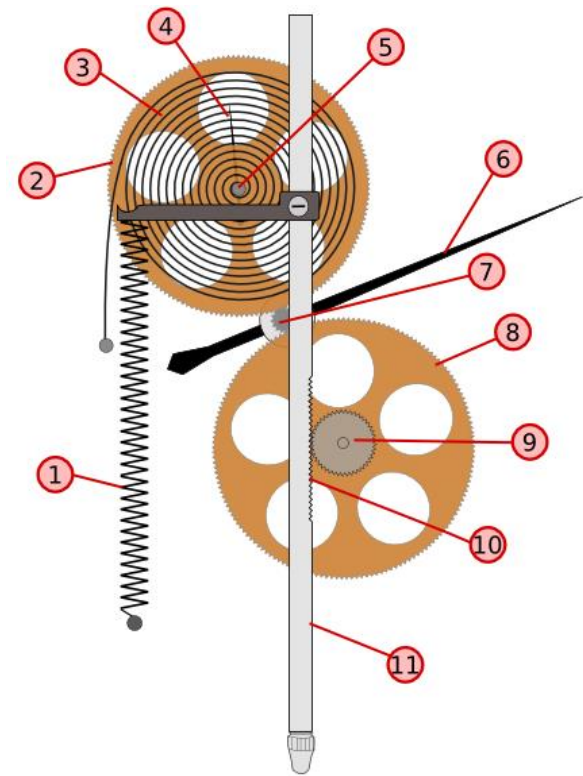
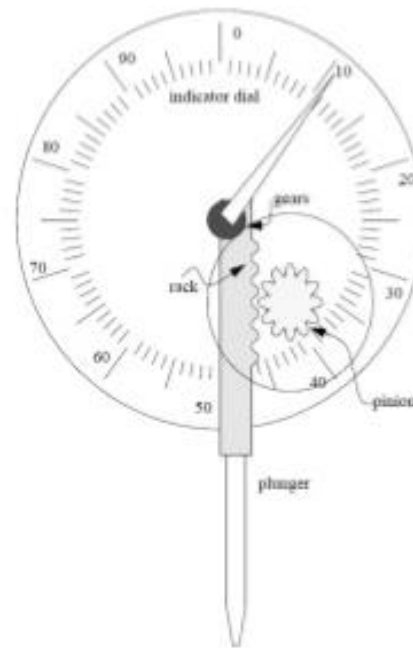



Engrenagem / Sem fim

Características

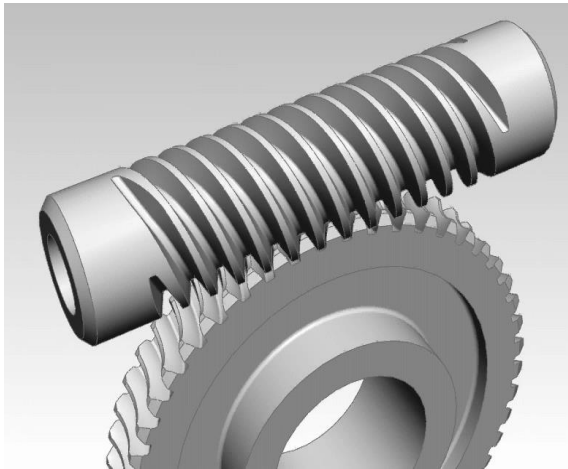

- Transmissão do movimento
- Direcionamento do movimento
- Amplificação / redução de velocidades
- Amplificação / redução de torque
- Forte dependência da qualidade das engrenagens e sem fins
- Fontes de vibrações
- Sugeitas a desgaste
- Ajustagem (problema de backlash)
- Ajustagem (problema run in)
- Erro de segmento na reversão



Engrenagem / Sem fim

dimensionamento

axial module, m_x , and normal pressure angle $\alpha_n = 20^\circ$.

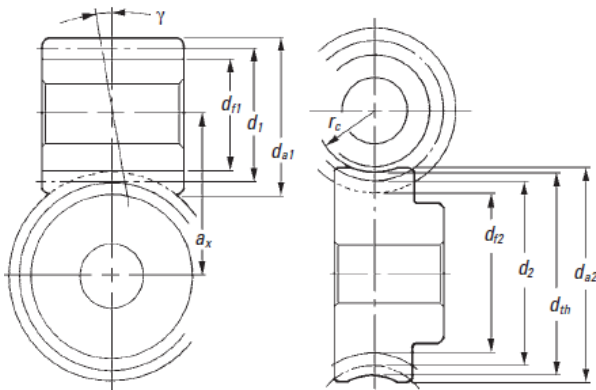

Dimensions of Cylindrical Worm Gears

- É o mesmo de elementos de máquinas clássico
- O cuidado é direcionado a fabricação

The Relations of Cross Sections of Worm Gears

Worm		
Axial Surface	Normal Surface	Radial Surface
$m_x = \frac{m_n}{\cos \gamma}$	m_n	$m_t = \frac{m_n}{\sin \gamma}$
$\alpha_x = \tan^{-1}\left(\frac{\tan \alpha_n}{\cos \gamma}\right)$	α_n	$\alpha_t = \tan^{-1}\left(\frac{\tan \alpha_n}{\sin \gamma}\right)$
$p_x = \pi m_x$	$p_n = \pi m_n$	$p_t = \pi m_t$
$L = \pi m_x Z_w$	$L = \frac{\pi m_n Z_w}{\cos \gamma}$	$L = \pi m_t Z_w \tan \gamma$
Radial Surface	Normal Surface	Axial Surface
Worm Gear		

NOTE: The Radial Surface is the plane perpendicular to the axis.

The Calculations of Axial Module System Worm Gears

No.	Item	Symbol	Formula	Example	
				Worm	Wheel
1	Axial Module	m_x		3	
2	Normal Pressure Angle	α_n		20°	
3	No. of Threads, No. of Teeth	Z_w, Z_2		∇	30 (R)
4	Standard Pitch Diameter	d_1 d_2	$\frac{Q}{Z_2} m_x$ $Z_2 m_x$ Note 1	44.000	90.000
5	Lead Angle	γ	$\tan^{-1}\left(\frac{m_x Z_w}{d_1}\right)$	7.76517°	
6	Coefficient of Profile Shift	x_{a2}		-	0
7	Center Distance	a_x	$\frac{d_1 + d_2}{2} + x_{a2} m_x$	67.000	
8	Addendum	h_{a1} h_{a2}	$1.00 m_x$ $(1.00 + x_{a2}) m_x$	3.000	3.000
9	Whole Depth	h	$2.25 m_x$	6.750	
10	Outside Diameter	d_{a1} d_{a2}	$d_1 + 2h_{a1}$ $d_2 + 2h_{a2} + m_x$ Note 2	50.000	99.000
11	Throat Diameter	d_{th}	$d_2 + 2h_{a2}$	-	96.000
12	Throat Surface Radius	r_t	$\frac{d_1}{2} - h_{a1}$	-	19.000
13	Root Diameter	d_{r1} d_{r2}	$d_{a1} - 2h$ $d_{th} - 2h$	36.500	82.500

Double-Threaded Right-Hand Worm



Redutores planetários

Características

redução:

$$R = \frac{D_{\text{ring}} + D_{\text{sun}}}{D_{\text{sun}}}$$

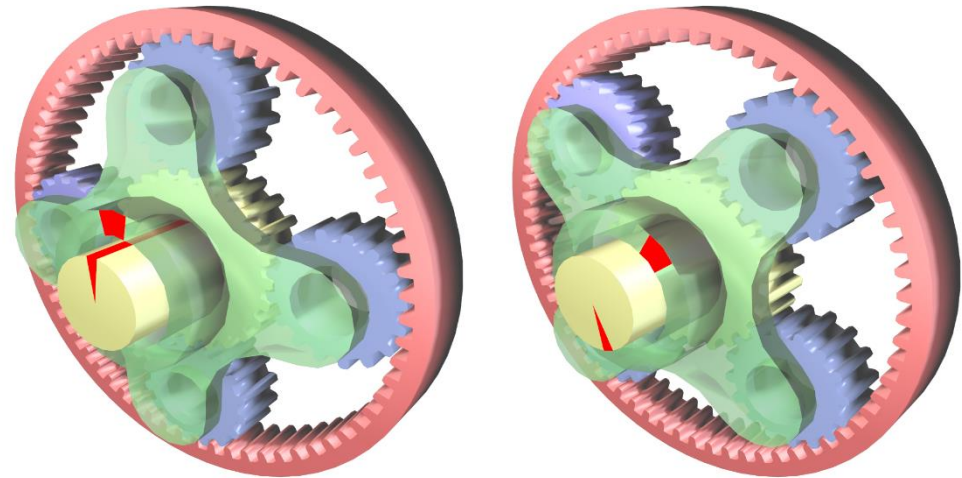

http://en.wikipedia.org/wiki/Epicyclic_gearing

folga < 3 minutos de arco (reductor de precisão)

folga < 15 minutos de arco (reductor normal)

taxa de redução: 3 (um estágio) a 200 (três estágios)

rendimento: 90 a 95%



Redutores planetários

Funcionamento

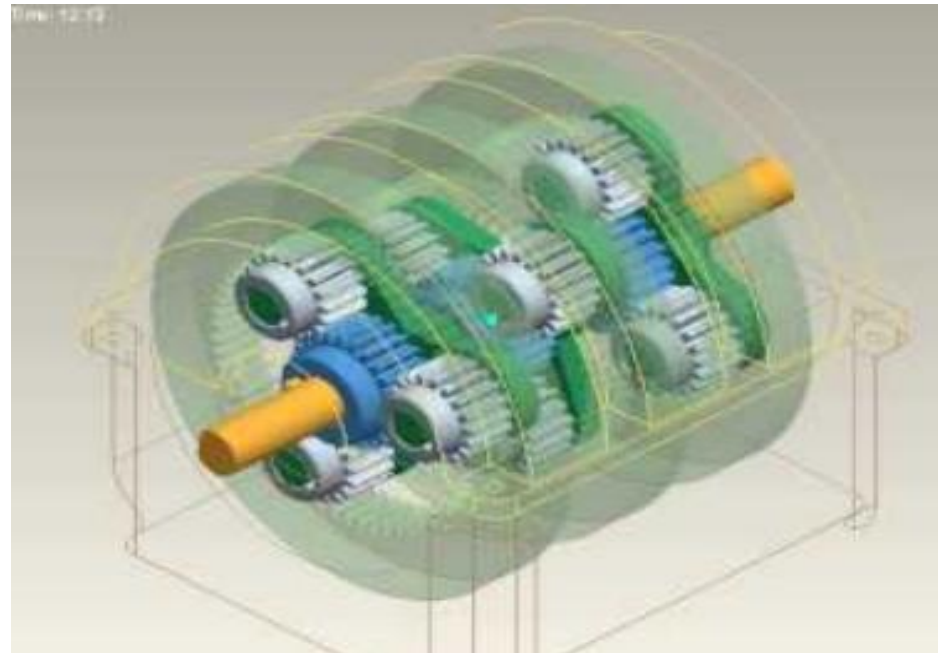

<http://www.youtube.com/watchv=HCYMF7XQzI>



Redutores planetários

Exemplos

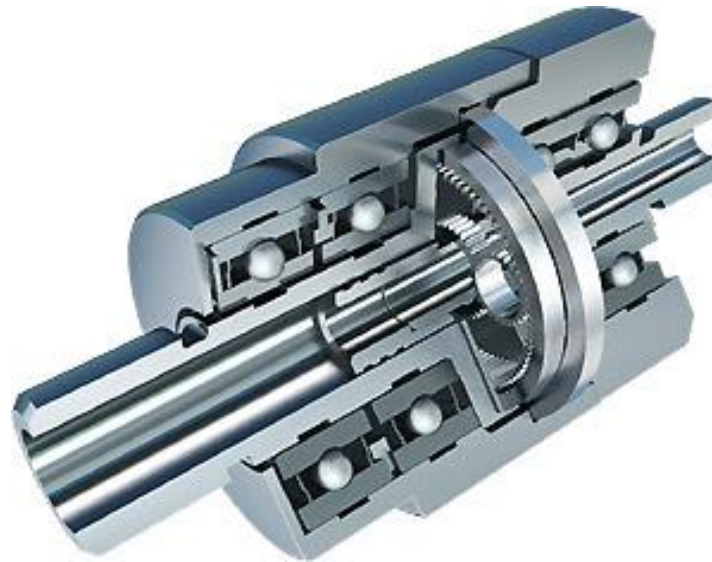

<http://www.mitsumiike.co.jp/english/product/power/transmission/>

http://www.propeng.com.au/catalog/product_info.php?cPath=22&products_id=197

<http://machinedesign.com/news/green-technology-jets-gear-fly-greener>



Harmonic drives

Características

- Sem folga: pré-carga
- Exatidão: ~ 1 minuto de arco
- Repetibilidade: poucos segundos de arco
- Eficiência: $\sim 90\%$
- Taxa de redução: 30 (50) a 320
- Baixa rigidez: engrenagem flexível





Harmonic drives

Características

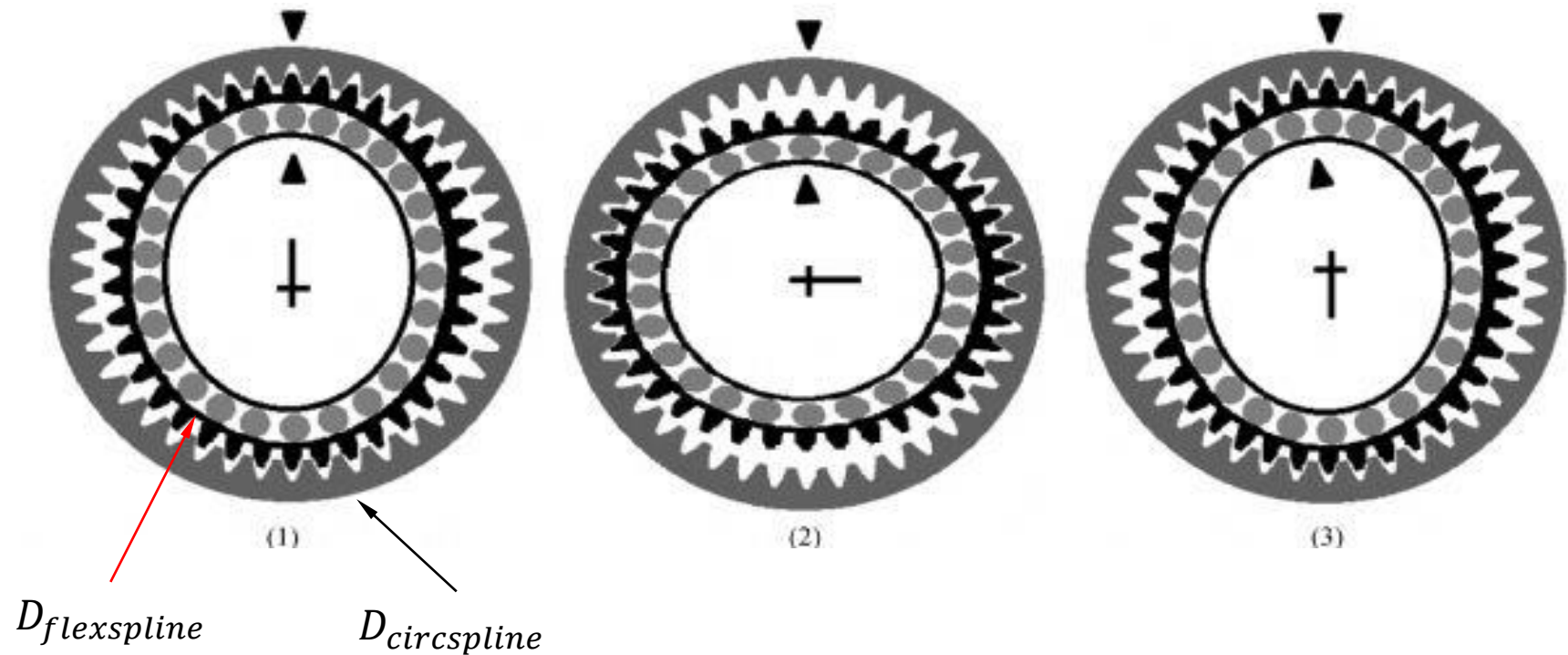

$$R = \frac{D_{flexspline}}{D_{circspline} - D_{flexspline}}$$



Harmonic drives

Constituintes





Harmonic drives

Constituintes

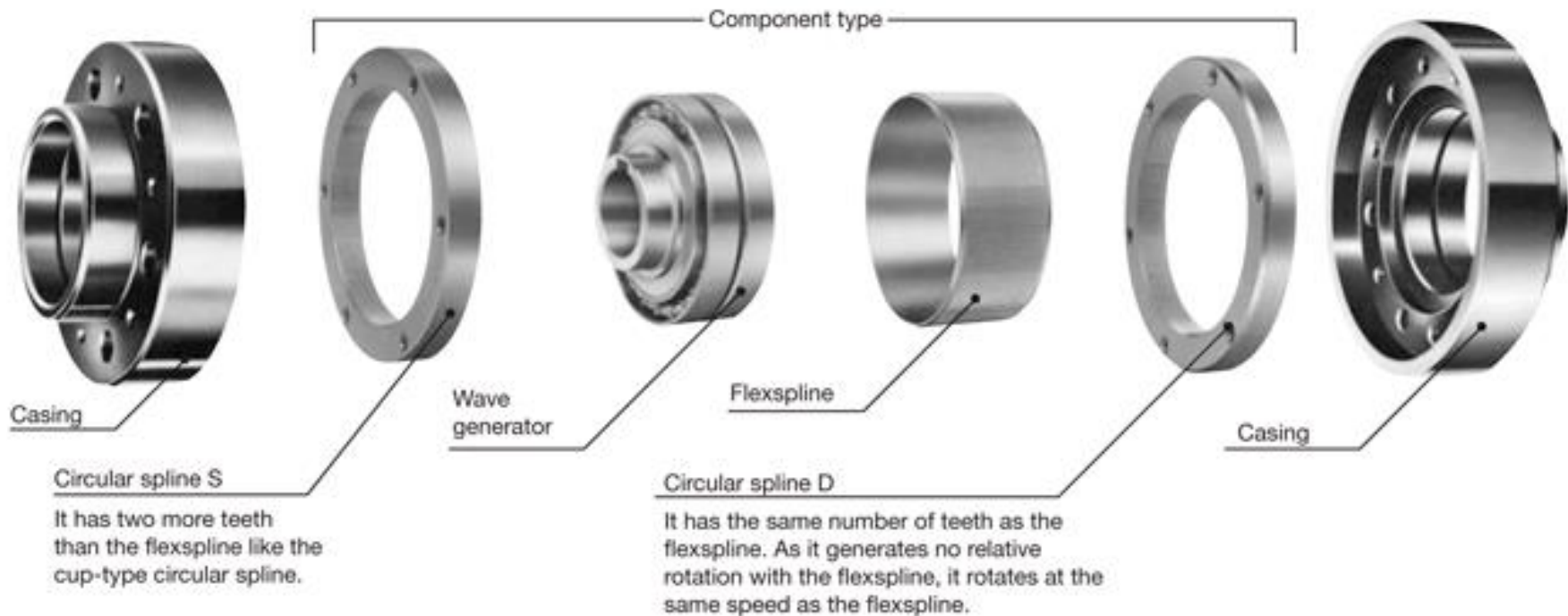



Harmonic drives

Configurações

Configurations

1. Reduction Gearing

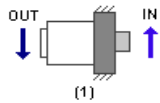

CS:Fixed
WG:Input
FS:Output

$$\text{Ratio: } i = -Z_R/2$$

Input and output in opposite direction

2. Reduction Gearing

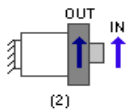

FS:Fixed
WG:Input
CS:Output

$$\text{Ratio: } i = Z_G/2$$

Input and output in same direction.

3. Reduction Gearing

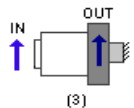

WG:Fixed
FS:Input
CS:Output

$$\text{Ratio: } i = Z_G/Z_R$$

Input and output in same direction.

4. Inceaser Gearing

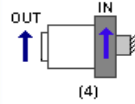

WG:Fixed
CS:Input
FS:Output

$$\text{Ratio: } i = Z_R/Z_G$$

Input and output in same direction.

5. Inceaser Gearing

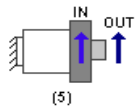

FS:Fixed
CS:Input
WG:Output

$$\text{Ratio: } i = 2/Z_G$$

Input and output in same direction.

6. Inceaser Gearing

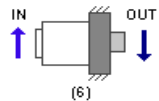

CS:Fixed
FS:Input
WG:Output

$$\text{Ratio: } i = -2/Z_R$$

Input and output in opposite direction.

7. Differential Gearing

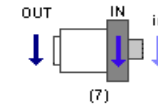

CS:Main Drive-Input
FS:Main Drive-Output
WG:Control Input

Output
Speed: $N_R = N_G \times (R+1) / R - N_W / R$

Numerous differential functions can be obtained by combinations of speeds and rotations on the three shafts

8. Differential Gearing

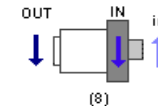

CS:Main Drive-Input
FS:Main Drive-Output
WG:Control Input

Output
Speed: $N_R = N_G \times (R+1) / R + N_W / R$

Numerous differential functions can be obtained by combinations of speeds and rotations on the three shafts.



Harmonic drives

Dimensionamento

①

Input: Circular spline S
 Output: Circular spline D
 Fixed: Wave generator
 Reduction ratio (i) is:

$$i = \frac{R+1}{R}$$

Hence, input rotation: N_i
 output speed: N_o1

$$N_{o1} = \frac{R+1}{R} N_i$$

②

Input: Wave generator
 Output: Circular spline D
 Fixed: Circular spline S
 Reduction ratio (i) is:

$$i = -\frac{1}{R}$$

Hence, input rotation: N_i
 output speed: N_{o2}

$$N_{o2} = -\frac{1}{R} N_i$$

When ① and ② are combined, the rotational speed of circular spline S is represented as shown on the right.

$$N_o = N_{o1} + N_{o2}$$

$$= \frac{R+1}{R} N_i (+) - \frac{1}{R} N_i$$

(Note) The sign (+) indicates that the wave generator is turned in the opposite direction to the circular spline S.



Harmonic drives

Dimensionamento

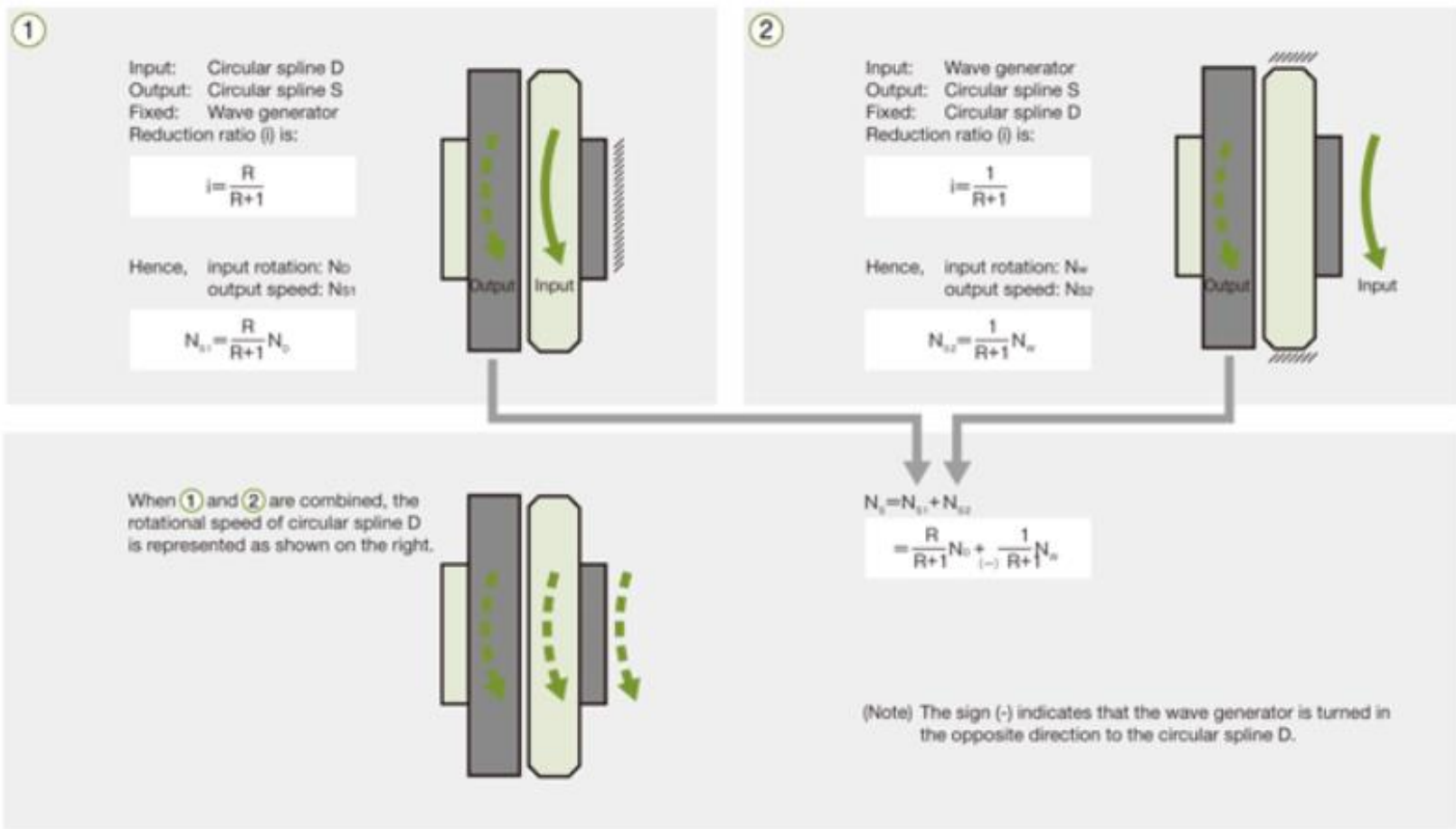



Capstan drives

Características

Reduções por cabos

Reduções até 50:1

Pré-carga: mola (< 10% da
tensão limite do cabo)

Capacidade de carga:
múltiplos cabos

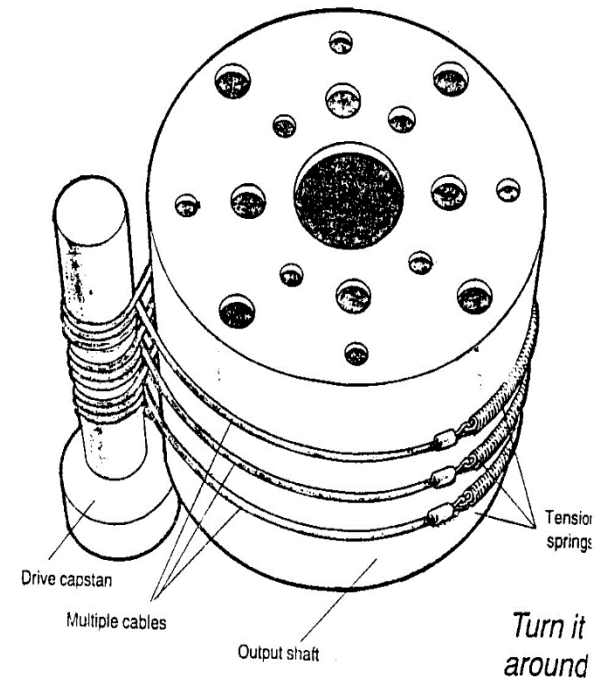



Capstan drives

Dimensionamento

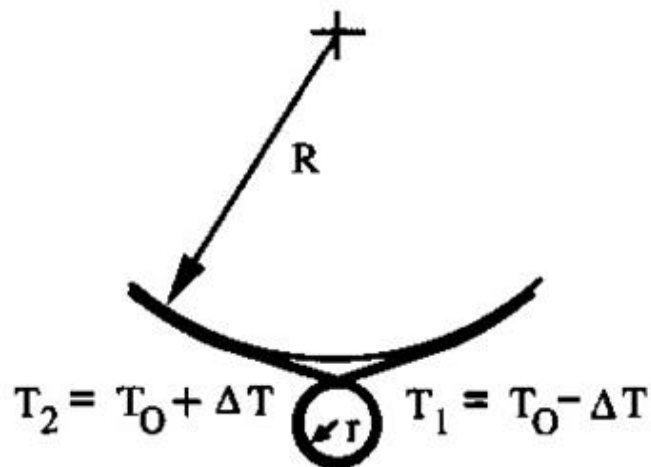

Ângulo de abraçamento:

$$\theta = \frac{\ln \frac{T_{\text{precarga}} + T_{\text{carga}}}{T_{\text{precarga}}}}{\mu}$$

redução:

$$R_d = \frac{R}{r}$$

Diâmetro da polia menor: $2r > 25d$

Diâmetro do cabo (d) em mm

(aço de alta resistência ~ 1.1 GPa)

$$d = 1,12 \left(\frac{T_{\text{saída}}}{n \cdot T \cdot R} \right)^{\frac{1}{3}}$$

sendo n = número de cabos

$torque_{\text{saída}}$ em N.m



Capstan drives

Exemplos



Synthetic Fiber Capstan Drives for
Highly Efficient Torque Control



Capstan drives

Exemplos

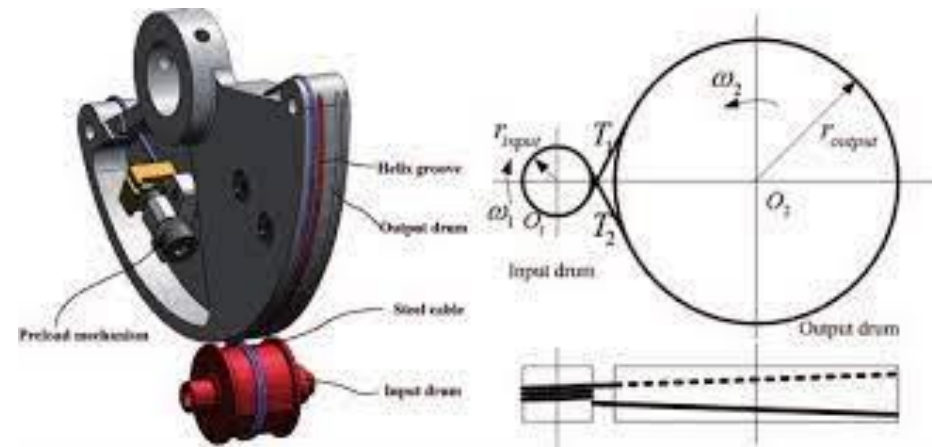
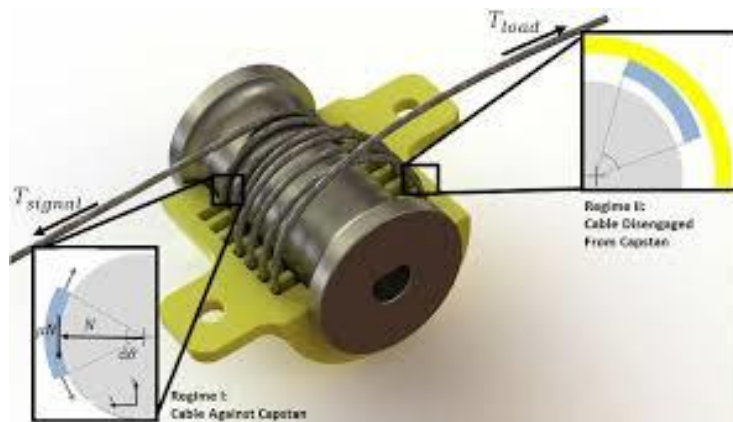



Rodas de atrito

Características



- Transmissão do movimento
- Movimento ultra suave
- Movimento sem backlash

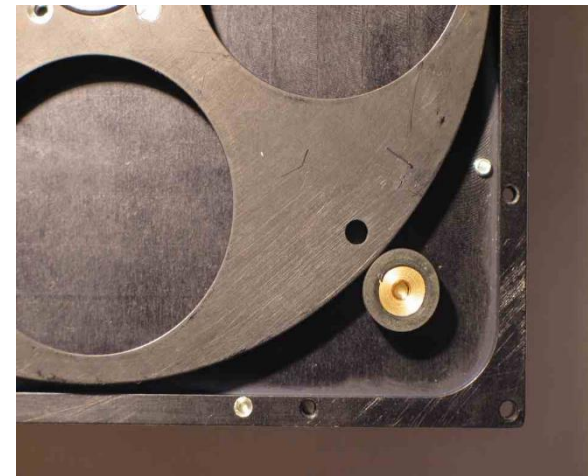



Rodas de atrito

Exemplos



26 Tonne Bridge Driven by Friction Drives



Friction Drives Used on the NANOCENTRE



ESCOLA POLITÉCNICA DA UNIVERSIDADE DE SÃO PAULO

FIM DA AULA