

- Aquisição dados
- Conversão DA
- Conversão AD
- Outros tipos de conversores AD
- Características de conversores AD e DA

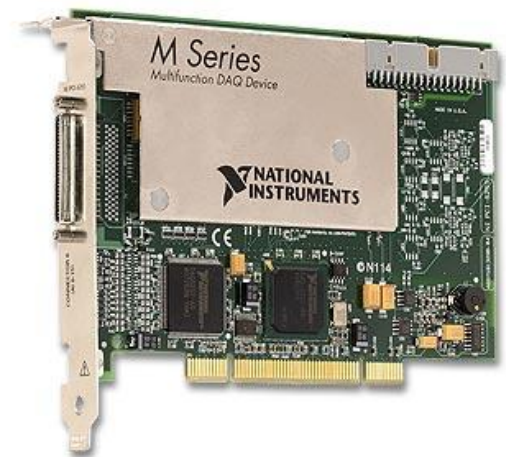

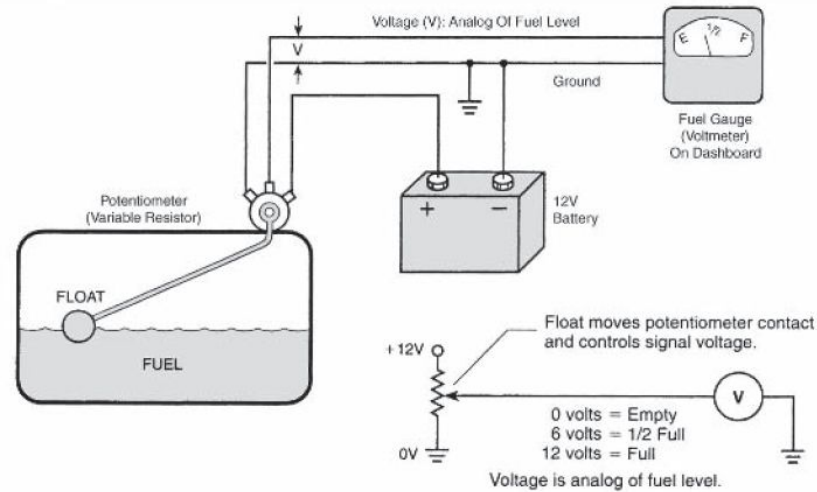

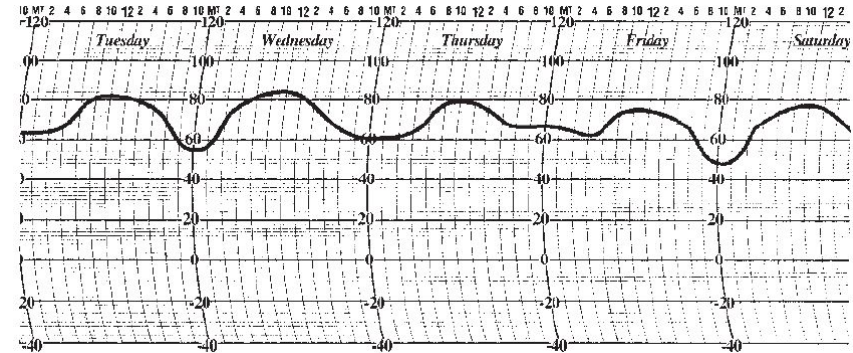
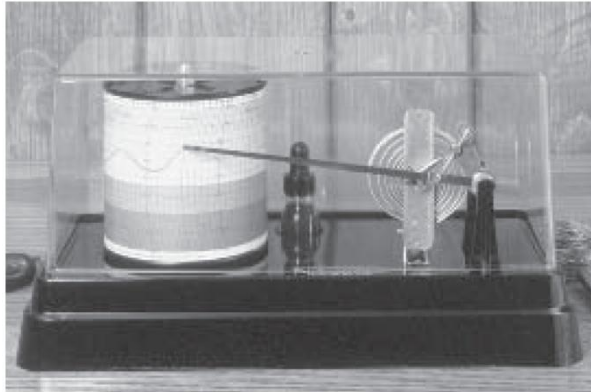

Multímetro

Osciloscópio

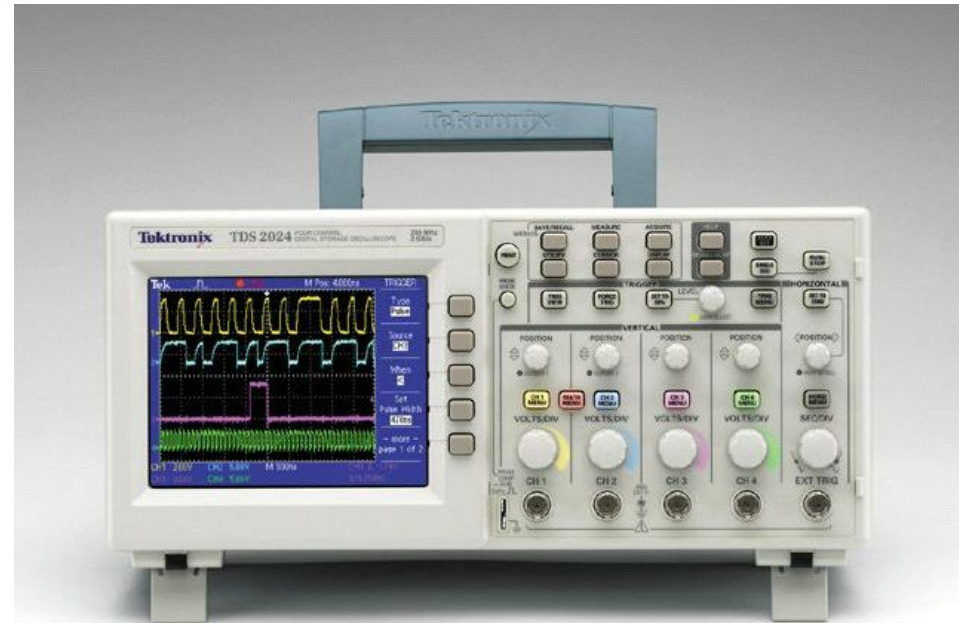

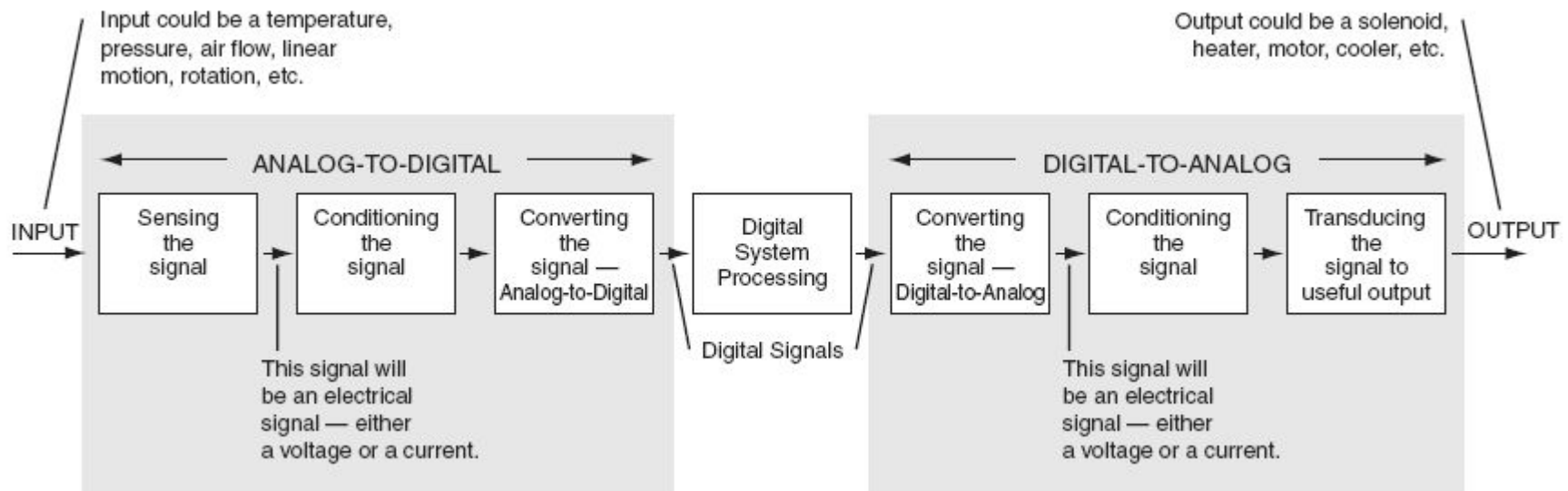

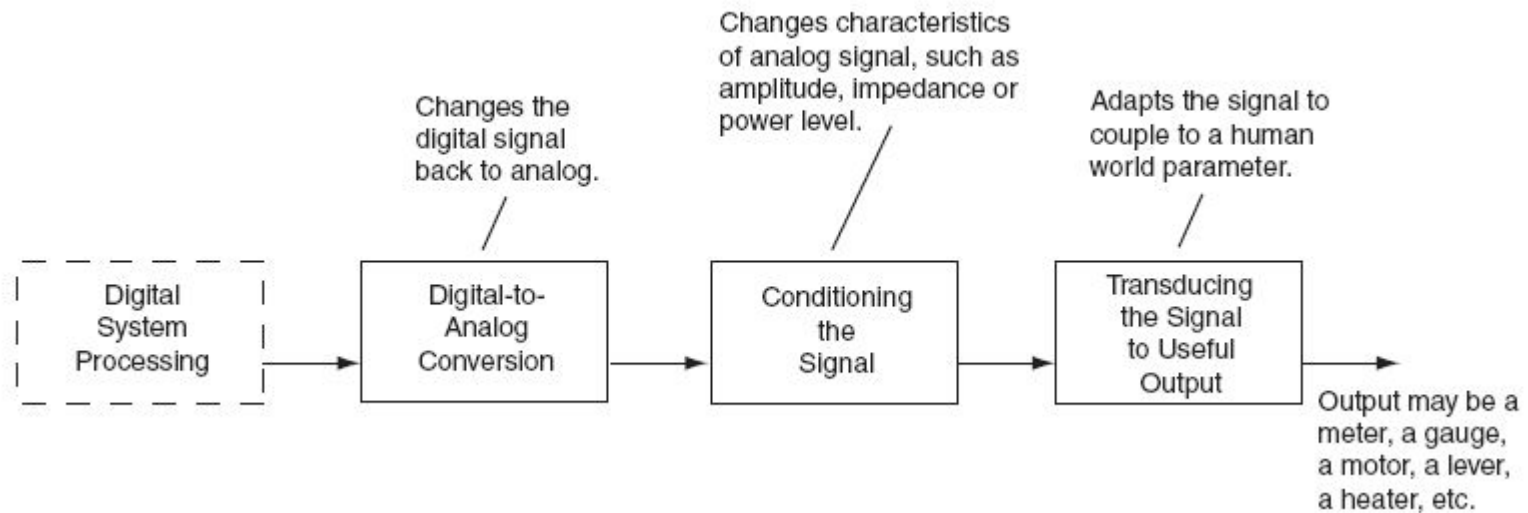

0's e 1's para níveis de tensão analógicos

Conversão para Sinal Analógico

DA com entrada digital binária ponderada

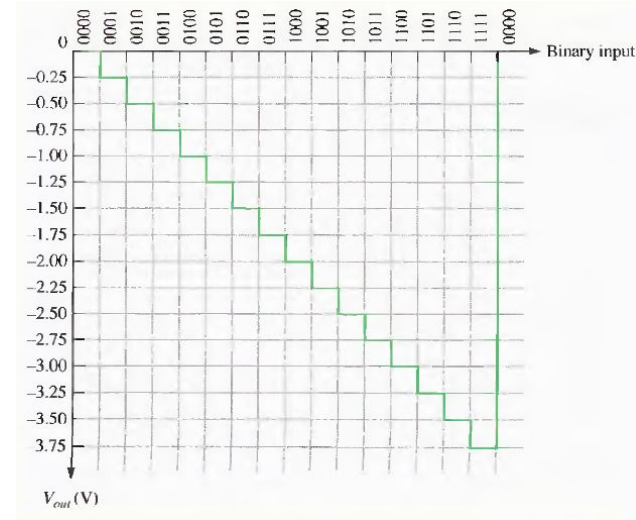
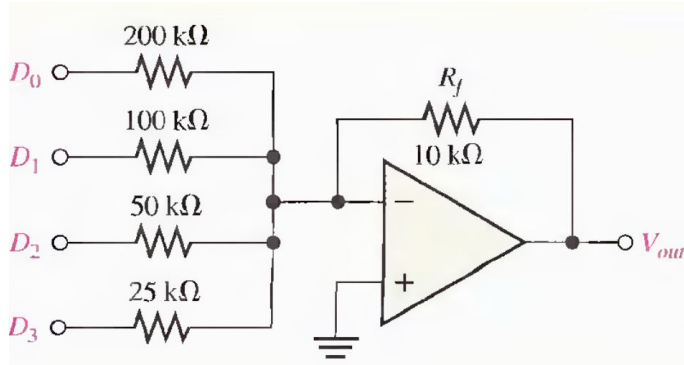

DA com cadeia de resistores

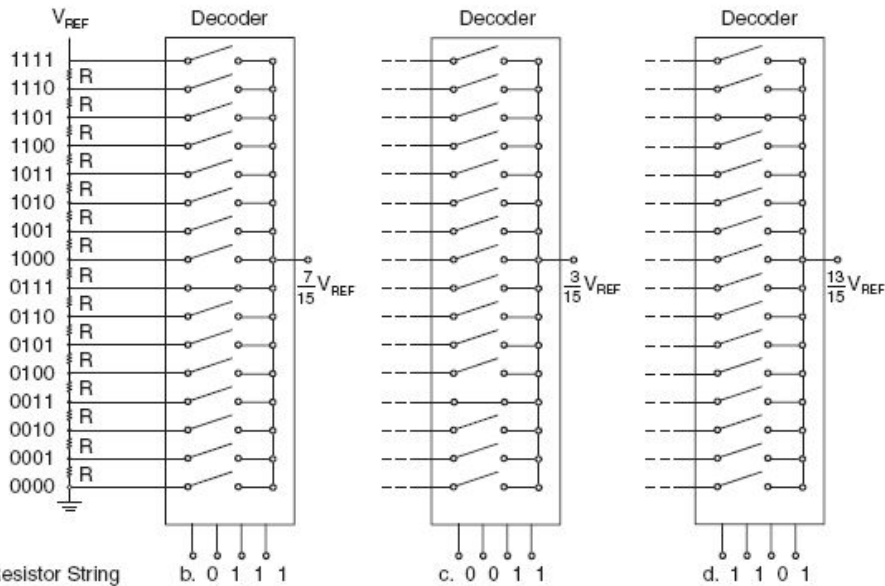

DA com escada R/2R

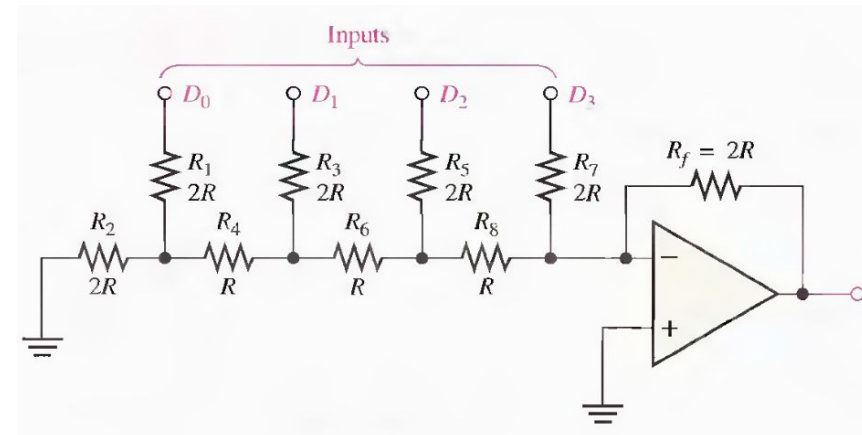

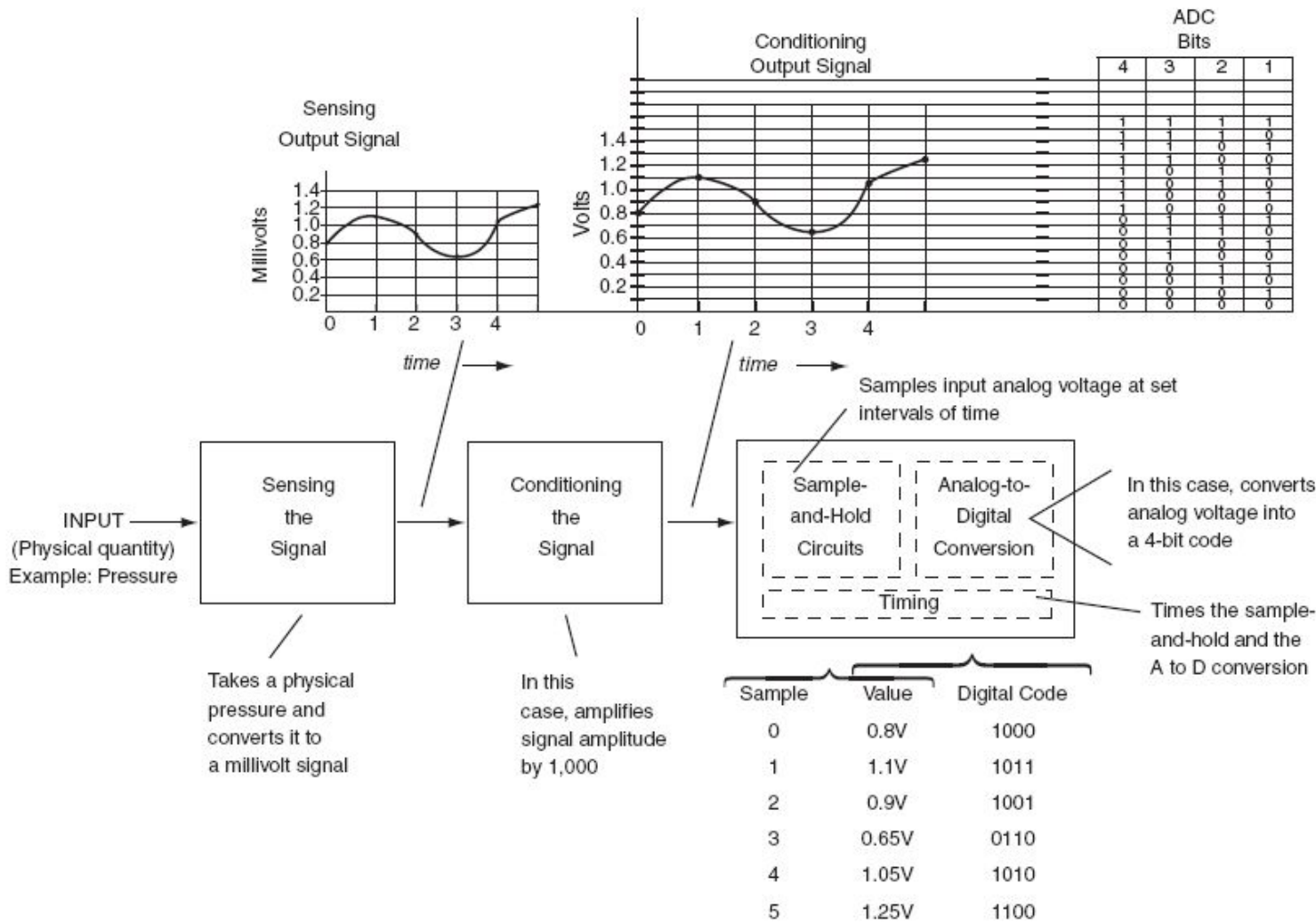

Conversão para Sinal Digital

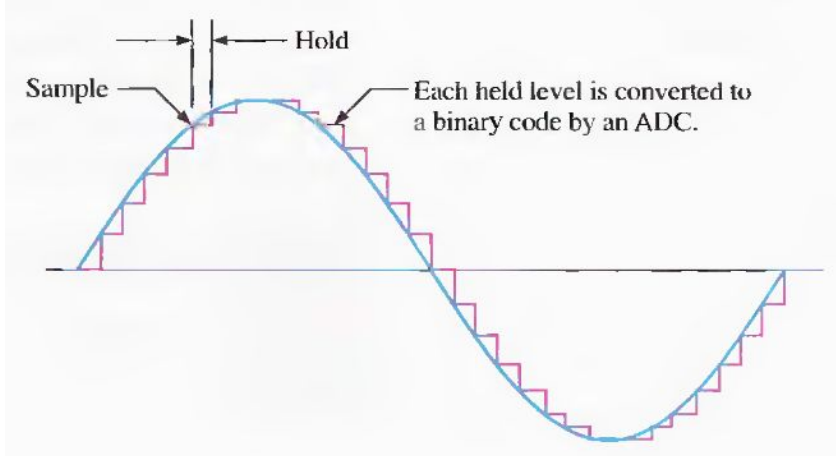

Representação em um determinado número de níveis

Amostrar e reter

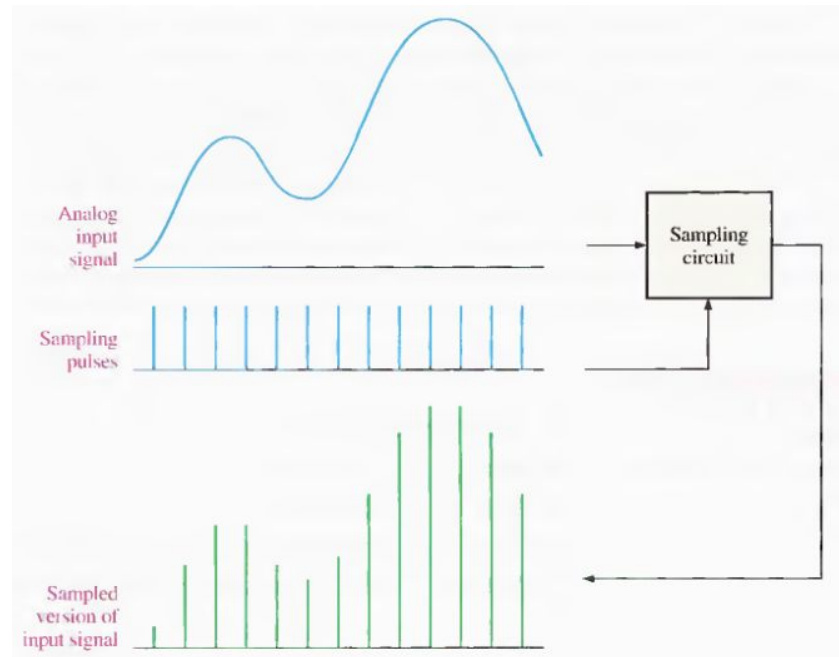
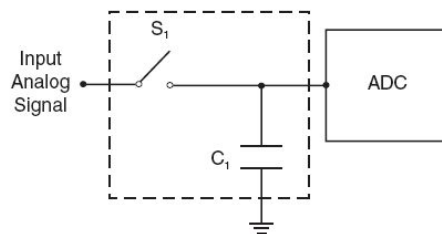

Amostrar e reter

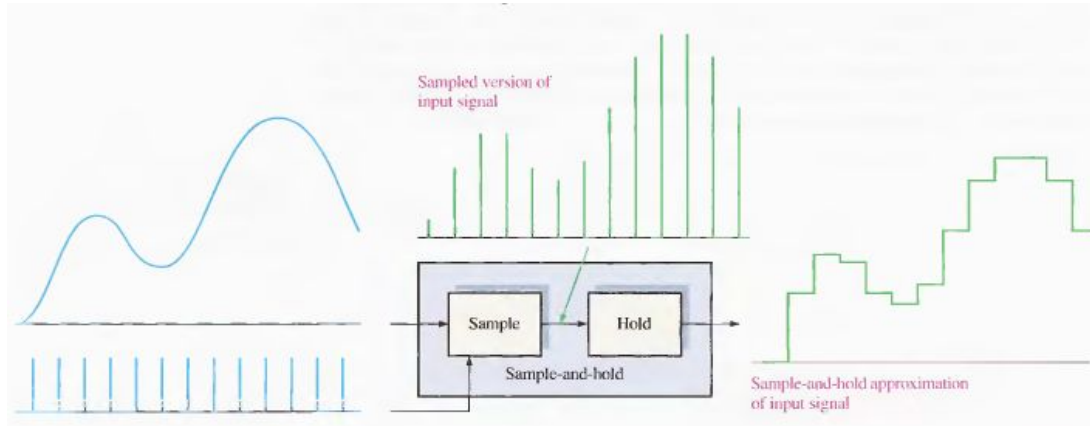

Amostras retidas → Números binários

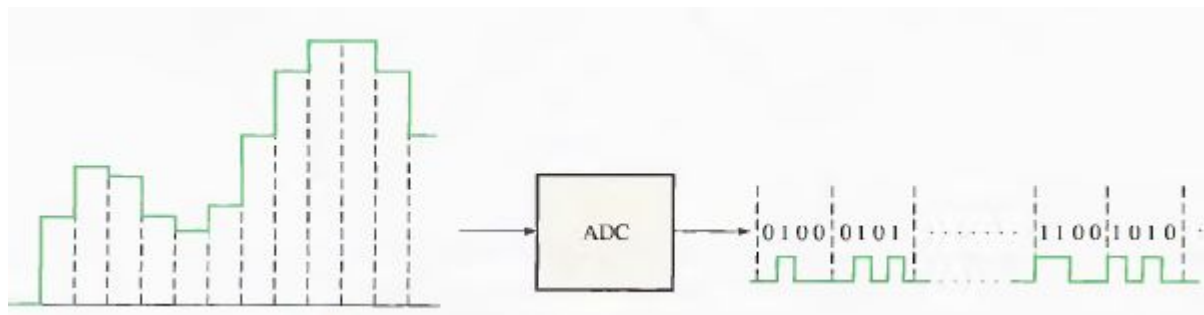

Conversor AD com contador binário

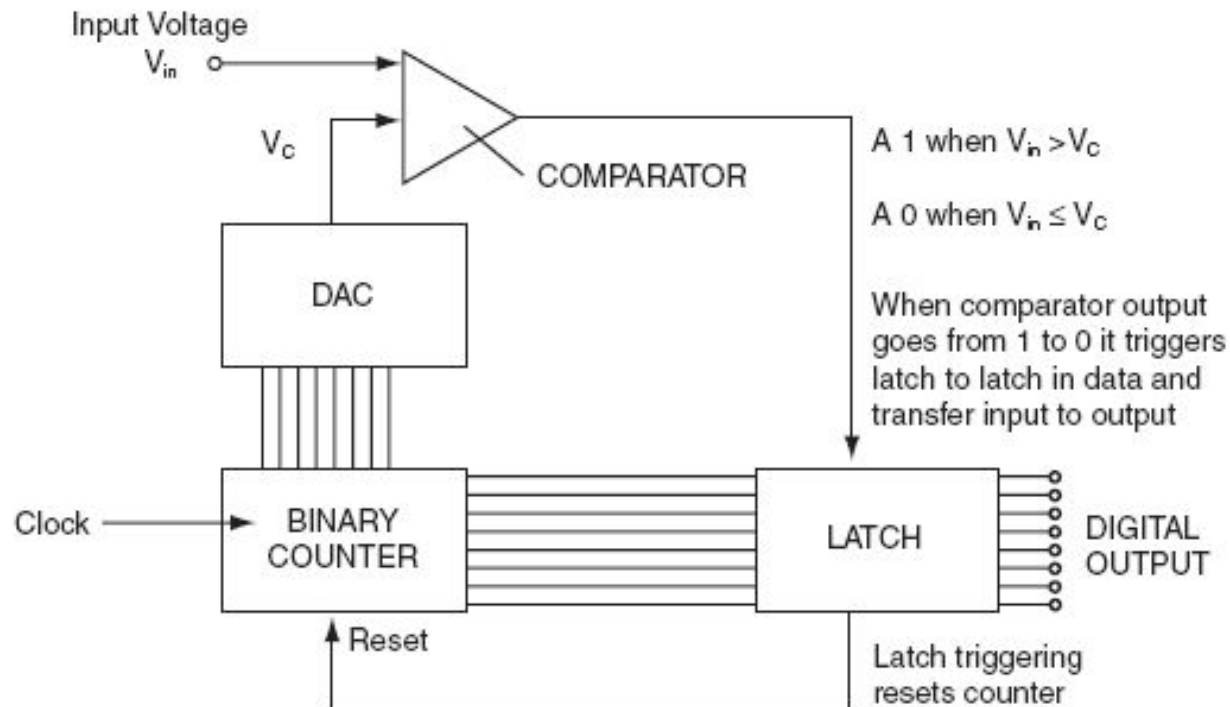

Conversor AD com Aproximação Sucessiva

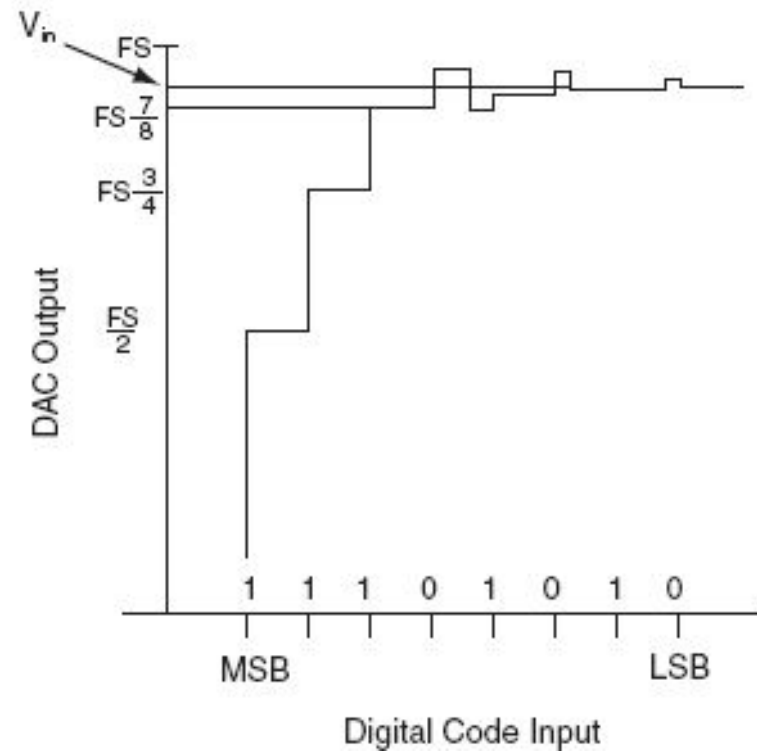
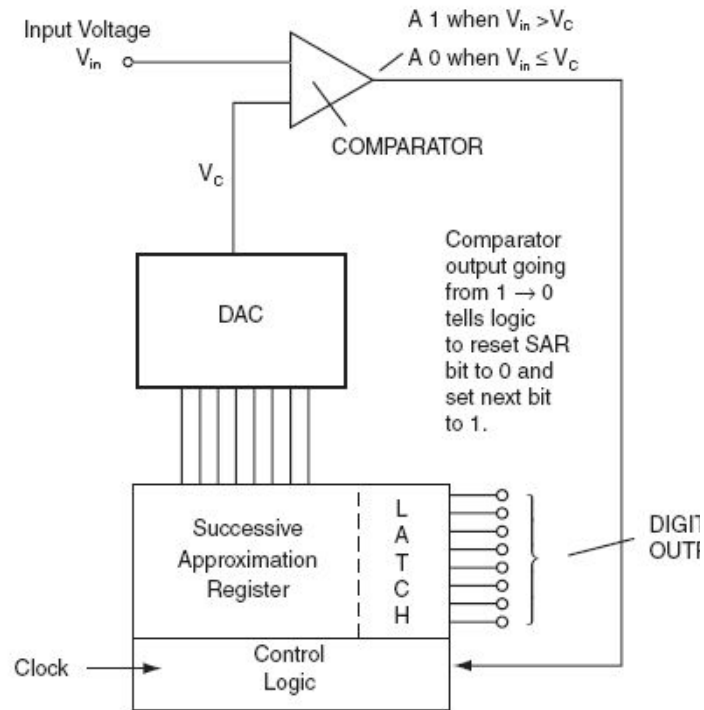

Conversor AD tipo Flash

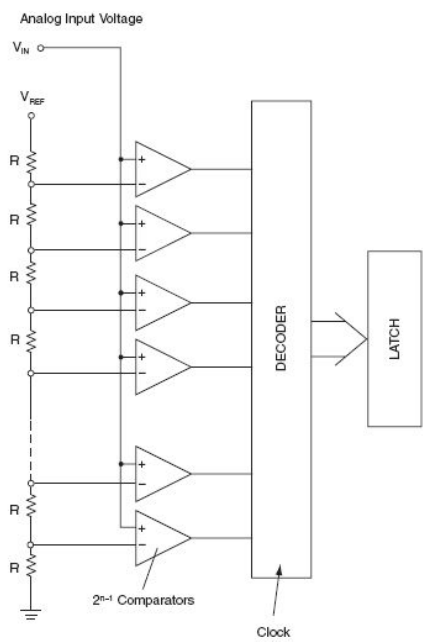

Conversor AD Dual-Slope

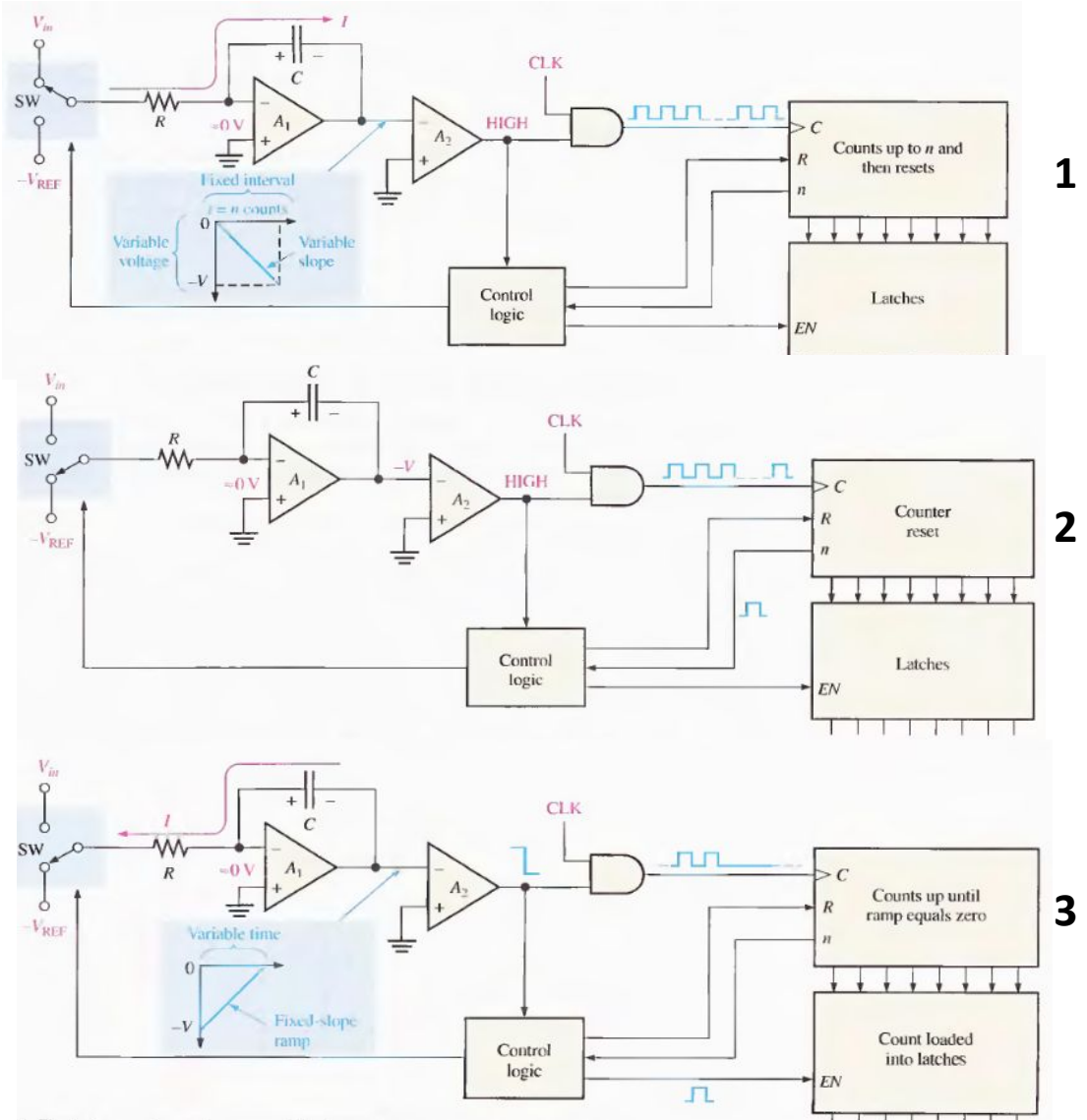

Conversão para Sinal Digital

Características de conversores AD e DA

Número de bits - n

Taxa de amostragem - S/s ou Hz

Faixa de tensão de entrada - ΔV

Resolução $Q = \frac{\Delta V}{2^n}$

Erro de quantização $e_q = \pm \frac{Q}{2}$

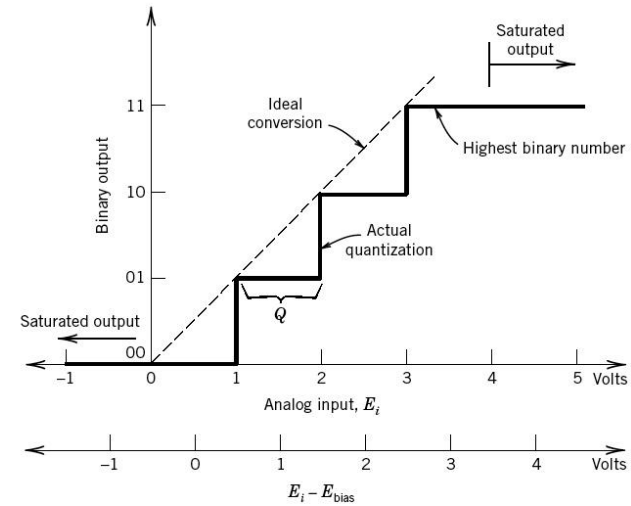
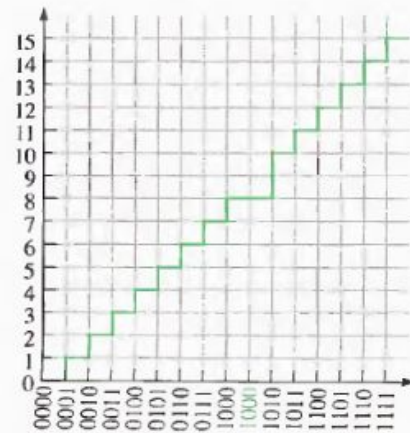
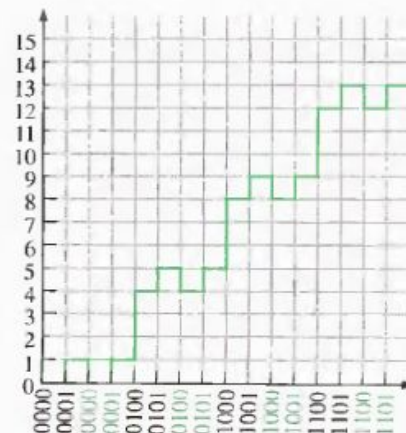

Figure 7.7 Binary quantization and saturation.



(a) Missing code (green)



(b) Incorrect codes (green)

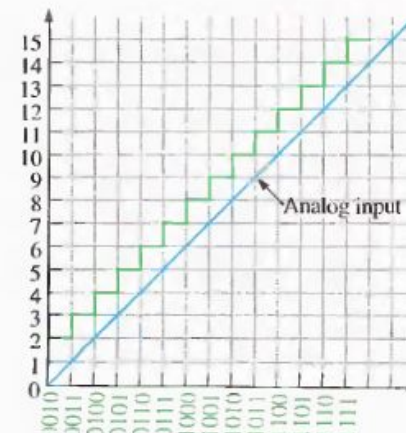

(c) Offset

Conversão para Sinal Digital

Características de conversores AD e DA

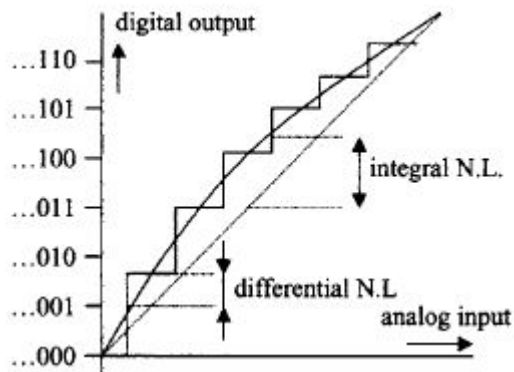

Não-linearidade diferencial e integral

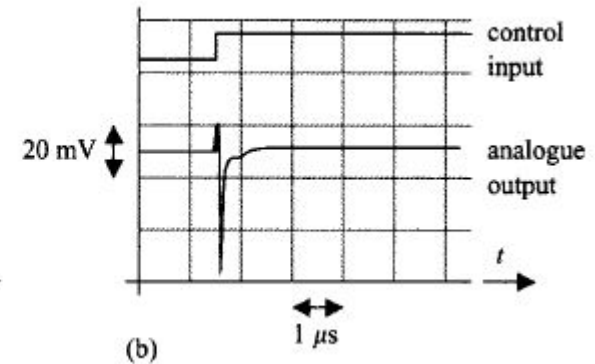
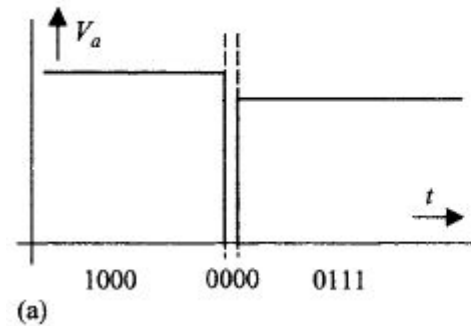

Glitching

Tempo de ajuste – settling time

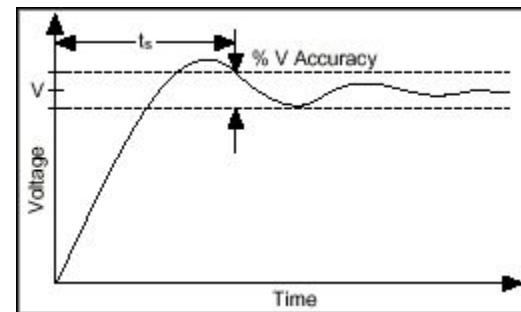
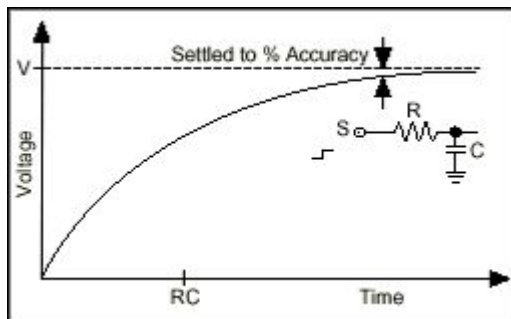

Conversão para Sinal Digital

Características de conversores AD e DA

Múltiplos canais

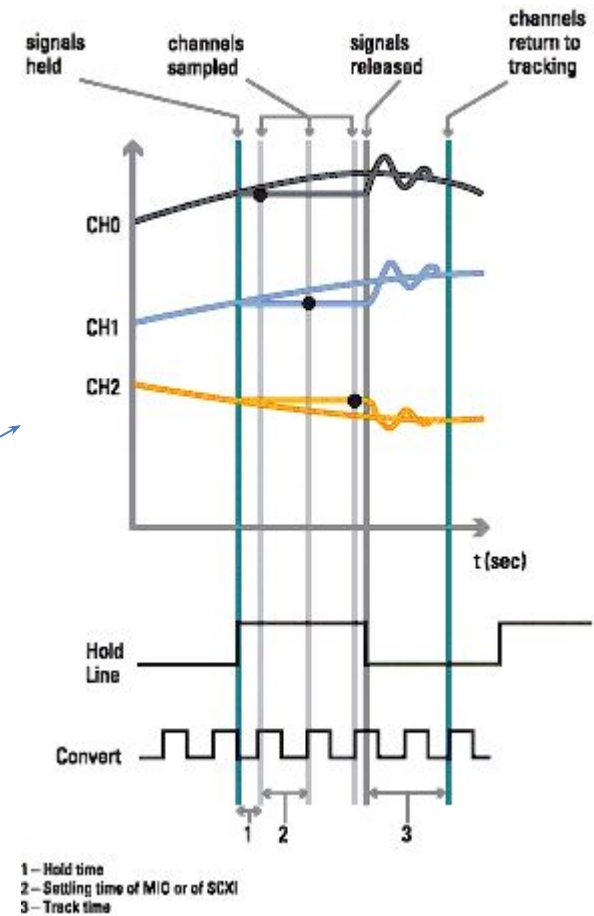
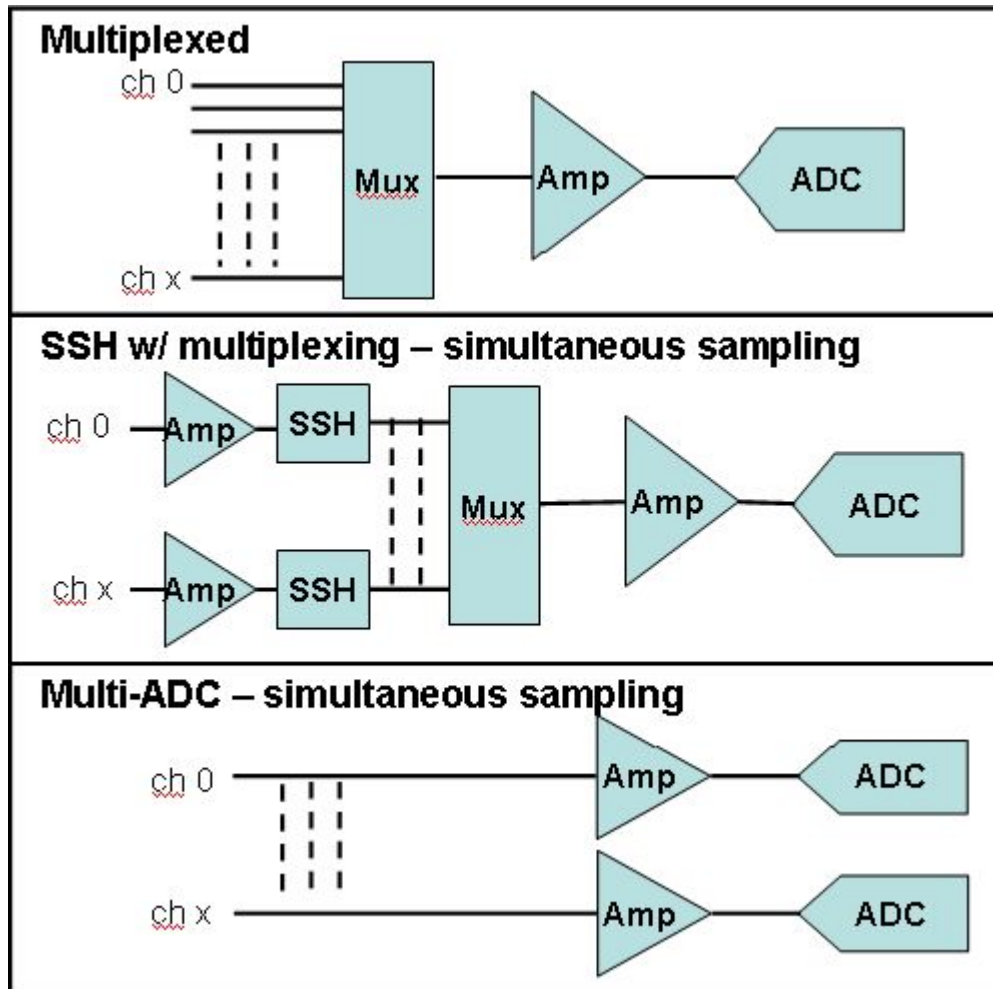

Aliasing

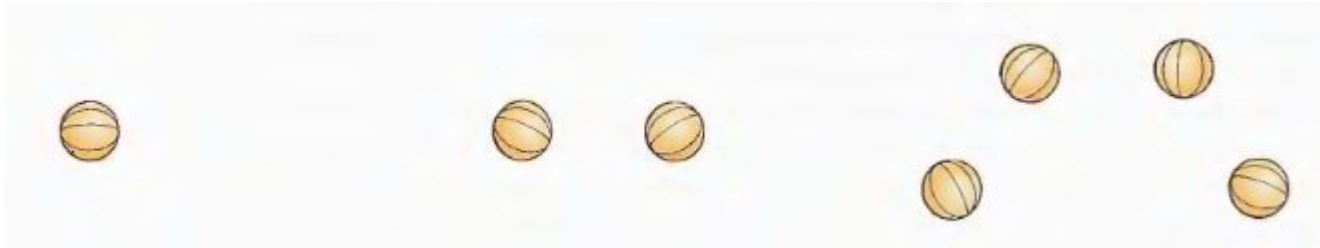

Diferentes tempos de amostragem

Conversão para Sinal Digital

Aliasing

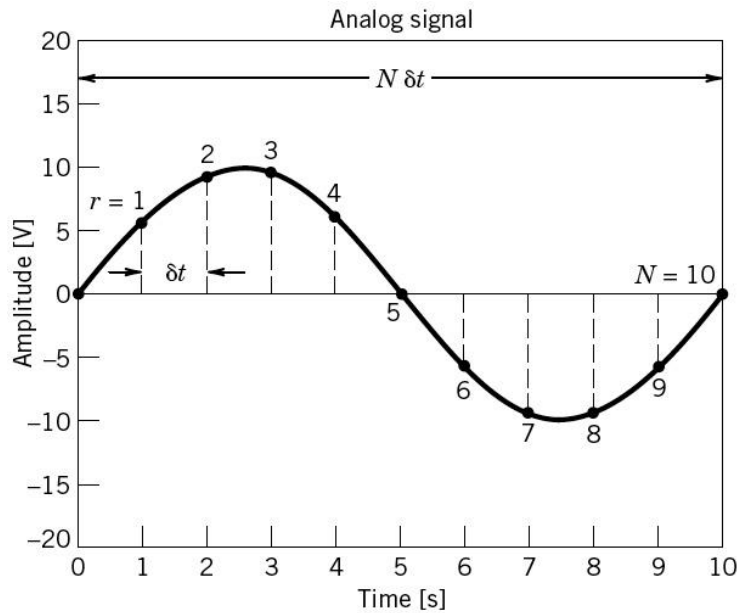

Discrete time signal	
$\{y(r\delta t)\}$	
r	Discrete data
0	0
1	5.9
2	9.5
3	9.5
4	5.9
5	0
6	-5.9
7	-9.5
8	-9.5
9	-5.9
10	0

Figure 7.1 Analog and discrete representations of a time-varying signal.

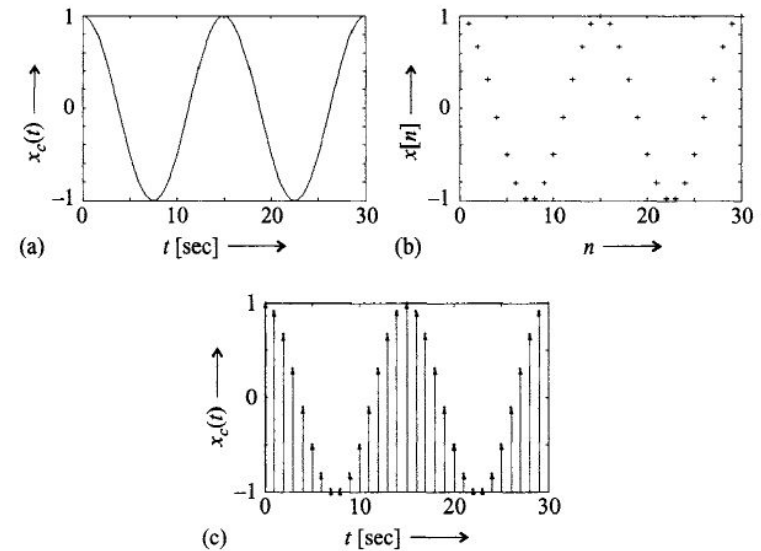

Conversão para Sinal Digital

Aliasing

Frequência de Nyquist

$$f_{\text{sampl}} \geq 2f_{\text{cut}}$$

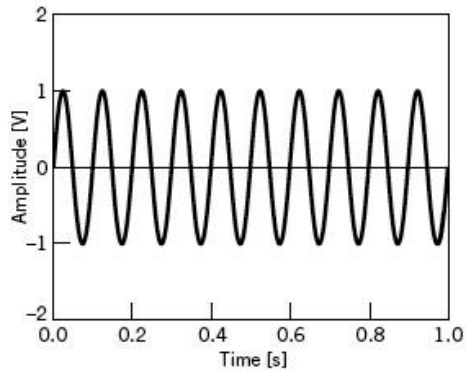

(a) Original 10-Hz sine wave analog signal

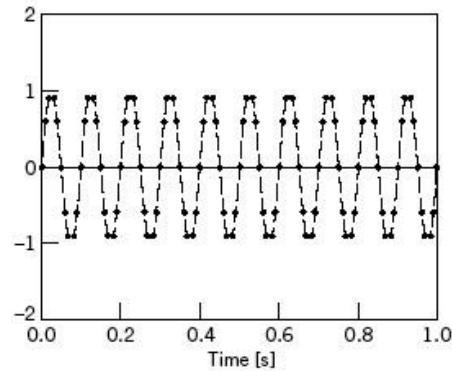

(b) $f_s = 100$ Hz

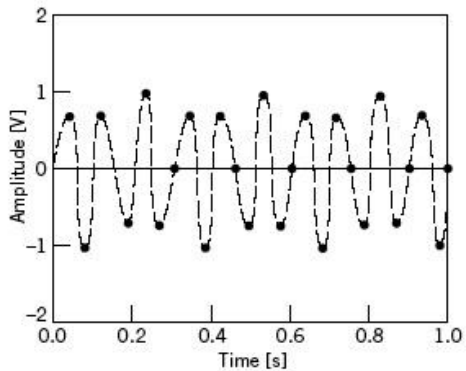

(c) $f_s = 27$ Hz

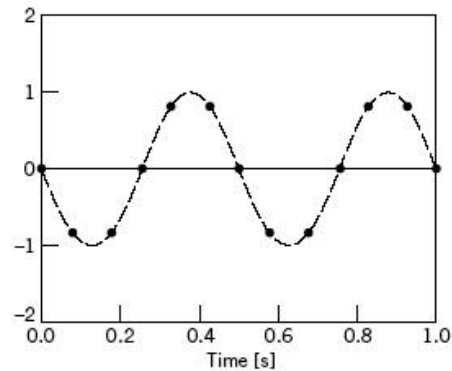

(d) $f_s = 12$ Hz

Figure 7.2 The effect of sample rate on signal frequency and amplitude interpretation.

Filtragem

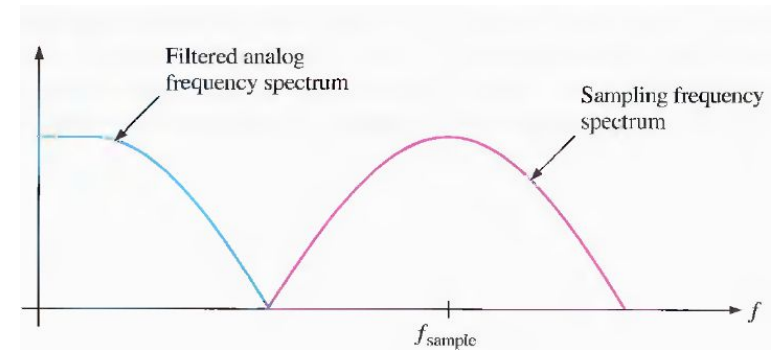
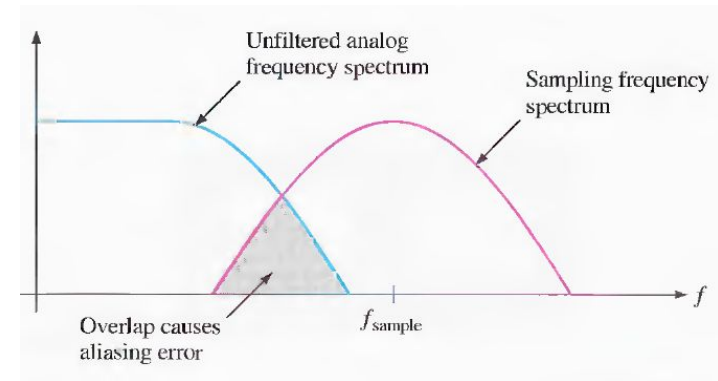

Na prática utilizam-se filtros de amostragem de freq. de corte pelo menos 5x menor que a freq. de amostragem

Conversão para Sinal Digital

Ambiguidade de amplitude - Leakage

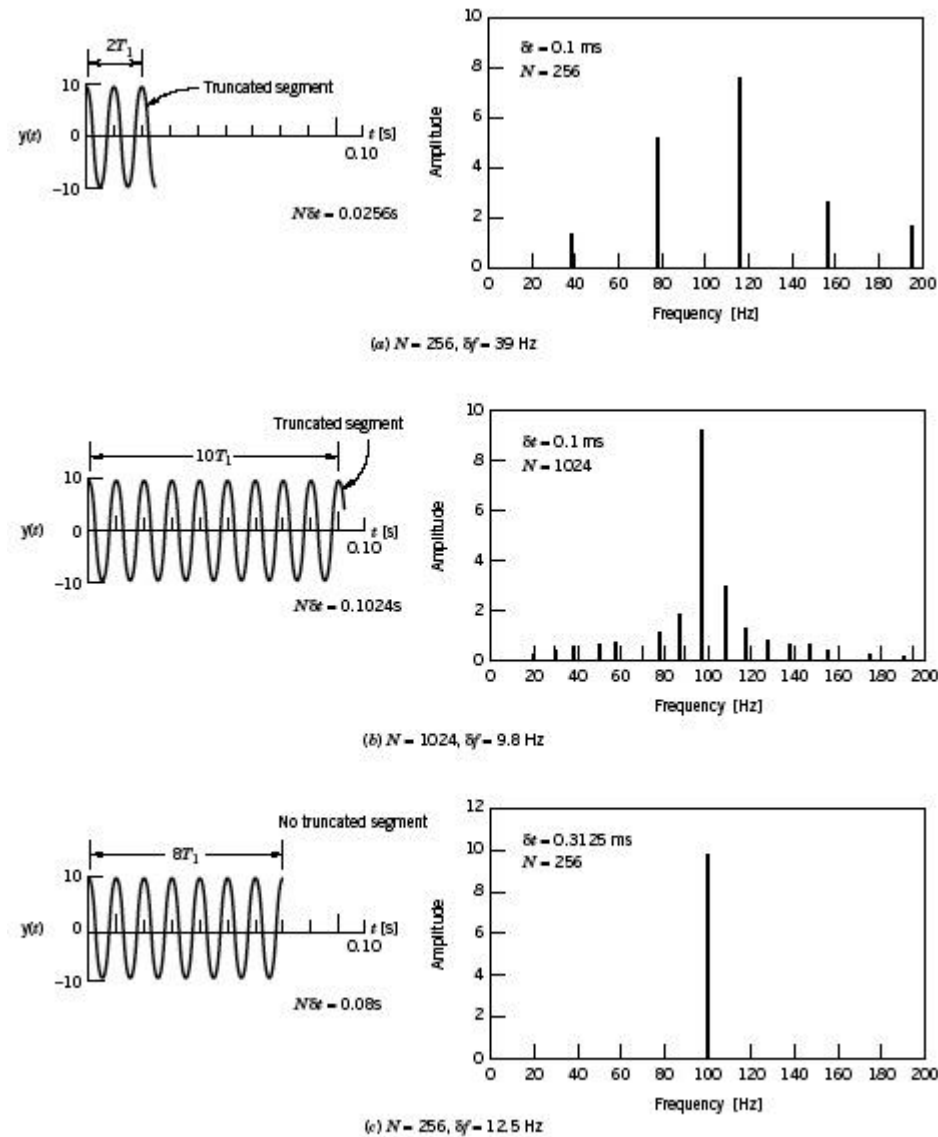
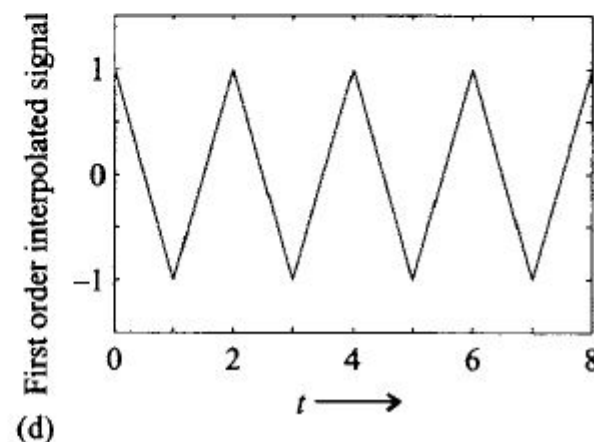
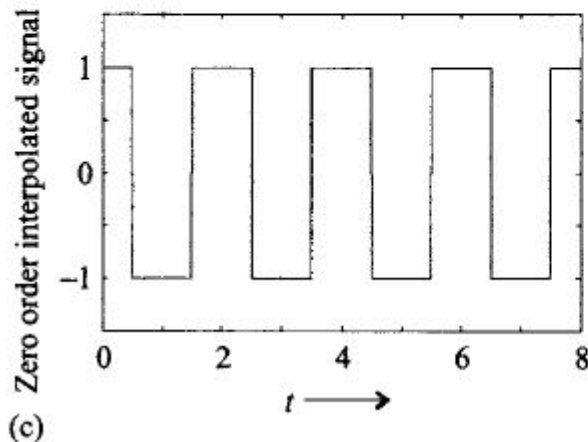
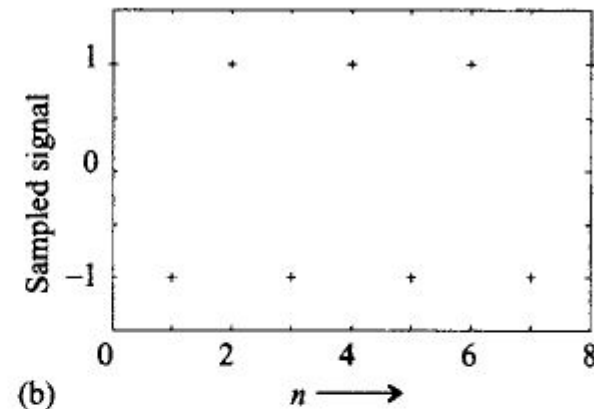
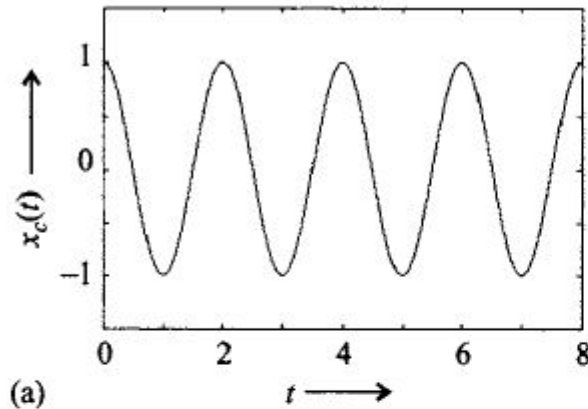

Figure 7.4 Amplitude spectra for $y(t)$. (a) $\delta f = 39$ Hz. (b) $\delta f = 9.8$ Hz. (c) $\delta f = 12.5$ Hz.

Conversão para Sinal Analógico

Filtro de reconstrução



Resposta ideal para um filtro de reconstrução

$$x_r(t) = \sum_{n=-\infty}^{\infty} x[n] \operatorname{sinc} \frac{\pi(t - n\Delta t)}{\Delta t}$$