

**ENGINEERING  
GEOLOGY  
FIELD  
MANUAL**

**SECOND EDITION**

**VOLUME I**

**1998**

**REPRINTED 2001**



**U.S. Department of the Interior  
Bureau of Reclamation**

The Mission of the Department of the Interior is to protect and provide access to our Nation's natural and cultural heritage and honor our trust responsibilities to tribes.

The Mission of the Bureau of Reclamation is to manage, develop, and protect water and related resources in an environmentally and economically sound manner in the interest of the American public.



Information contained in this manual regarding commercial products or firms may not be used for advertising or promotional purposes and is not an endorsement of any product or firm by the Bureau of Reclamation.

The information contained in this manual was developed for the Bureau of Reclamation; no warranty as to the accuracy, usefulness, or completeness is expressed or implied.

---

For sale by the Superintendent of Documents, U.S. Government Printing Office  
Internet: [bookstore.gpo.gov](http://bookstore.gpo.gov) Phone: (202) 512-1800 Fax: (202) 512-2250  
Mail: Stop SSOP, Washington, DC 20402-0001

## **Acknowledgments for Second Edition**

The original compilation and preparation of this manual involved many engineering geologists and geophysicists within Reclamation. Their input is greatly appreciated. This second edition incorporates comments on the first edition and technological changes since the first edition was prepared approximately 10 years ago. Without the comments and input from the Denver, Regional, and Area Offices the revision would not have happened. Special thanks to Sam Bartlett, Engineering Geology Group 1 Manager, for his support and input throughout the preparation of the manual.

Although there are too many people to acknowledge individually who contributed to the revisions and the second edition, Frank Calcagno, Mel Hill (retired), Sandy Kunzer, Jeff Farrar, Sharon Hebenstreit, Linda Arrowwood, and Peter Rohrer made especially significant contributions. Mark McKeown contributed to and edited the second edition.

Continued recognition is given to Jerry S. Dodd (retired), who initiated the manual; Jerry's successor, Newcomb Bennett (retired), who kept the manual moving; and to Steve D. Markwell (retired), who saw the first edition completed. We extend our thanks and appreciation to Louis R. Frei, who helped establish and document many geological standards of practice, and to Richard H. Throner, who wrote much of the original manual, who assembled and served on committees for preparation and review, to Sam R. Bartlett who compiled and printed the early loose leaf version of the manual, and to Mel Hill who completed the publication of the first edition. To the Regional Geologists and their staffs and the many geotechnical engineers who offered comments that have been incorporated into the manual we extend our thanks and appreciation for their work as well. The manual would not be complete without the drawings and figures; to the engineering and physical science technicians we extend our gratitude and thanks.



## FOREWORD TO THE SECOND EDITION

Approximately 10 years have gone by since the first edition was published, and technology and missions have changed significantly. This second edition incorporates many modifications and additions. The Global Positioning System (GPS) has revolutionized how we survey and locate ourselves in the field, computers are used extensively to collect and evaluate data, and computer aided modeling, design, and drafting are almost universal. Reclamation has a greater emphasis on maintenance and safety of infrastructure, dam safety analyses and modifications, and water resource management than on design and construction of new hydraulic structures. Techniques for these activities and environmental restoration/hazardous waste remediation activities are reflected in this edition.

A few of the most significant changes to the manual are the addition of a section on concrete core logging, a chapter on hazardous waste site investigations, and an index to facilitate finding relevant information. Many other suggested revisions and improvements collected since the manual was first published also are incorporated. *The manual now is in two volumes.* Volume I contains material commonly needed in the field, and Volume II includes reference or other material.

As in the first edition, the *Engineering Geology Field Manual* presents the practices for the collection of geologic data obtained by the Bureau of Reclamation. The manual establishes common guidelines, procedures, and concepts for the collection, evaluation, and presentation of geologic information. The analysis of geologic conditions, the preparation of designs and specifications, and effective construction monitoring and use of geological information to assess site characteristics and risk, require consistent, comprehensive, and timely geologic

information. The use of these guidelines by all Reclamation engineering geologists collecting, documenting, evaluating, and presenting geological and geotechnical data promotes consistency, helps assure that the required evaluations and data are complete, and promotes integration and coordination of geological and engineering activities.

The Engineering Geology Field Manual, in conjunction with the Engineering Geology Office Manual, forms the basis for the mutually beneficial exchange of ideas by Reclamation geologists. Experienced geologists will find useful reminders and new procedures and special techniques, while less experienced engineering geologists and those from other disciplines can use the manual to expand their familiarity with geology as practiced in the Bureau of Reclamation.

Review and comments on the manual are encouraged, and if you have comments or suggested additions, please forward them to the Technical Service Center Engineering Geology Groups.

Richard Throner  
Leadership Team Member  
Geotechnical Services

# CONTENTS

	<i>Page</i>
Acknowledgments .....	iii
Foreword .....	v
Chapter 1 Introduction .....	1
Chapter 2 Geologic Terminology and Classifications for Geologic Materials .....	3
Established References for Geological Terminology .....	3
Geologic Classification of Materials .....	4
Engineering Classification of Geologic Materials .....	5
Application and Use of Standard Indexes, Terminology, and Descriptors .....	9
Units of Measurements for Geologic Logs of Exploration, Drawings, and Reports ..	12
Bibliography .....	15
Chapter 3 Engineering Classification and Description of Soil .....	17
General .....	17
Classifications of Soils .....	21
Abbreviated Soil Classification Symbols ...	39
Description of the Physical Properties of Soil .....	40
Narrative Descriptions and Examples .....	48
Use of Soil Classification as Secondary Identification Method for Materials Other Than Natural Soils .....	51
Bibliography .....	56
Chapter 4 Classification of Rocks and Description of Physical Properties of Rock .....	57
Introduction .....	57
Rock Classification .....	57

# FIELD MANUAL

## Chapter 4 Classification of Rocks and Description of Physical Properties of Rock (continued)

	<i>Page</i>
Description of Rock .....	59
Example Descriptions .....	86
Bibliography .....	90
Chapter 5 Terminology and Descriptions for Discontinuities .....	91
General .....	91
Indexes for Describing Fracturing .....	94
Description of Fractures .....	98
Descriptions of Shears and Shear Zones ...	114
Bibliography .....	126
Chapter 6 Geologic Mapping and Documentation .....	129
Responsibilities of the Engineering Geologist .....	129
Development of a Study Plan .....	130
Specific Mapping Requirements .....	133
Global Positioning System .....	135
Site Mapping .....	153
Dozer Trench Mapping .....	157
Backhoe Trench Mapping .....	161
Construction Geologic Mapping .....	167
Large Excavation Mapping .....	168
Steep Slope Mapping .....	169
Canal and Pipeline Mapping .....	170
Underground Geologic Mapping .....	171
Underground Geologic Mapping Methods ..	185
Photogeologic Mapping .....	196
Analysis of Aerial Photographs .....	198



## CONTENTS

### Chapter 6 Geologic Mapping and Documentation (continued)

	<i>Page</i>
Photoanalysis for Reconnaissance	
Geologic Mapping .....	199
Availability of Imagery .....	200
References .....	202
Bibliography .....	203
Chapter 7 Discontinuity Surveys .....	205
General .....	205
Bibliography .....	211
Chapter 8 Exploration Drilling	
Programs .....	213
Introduction .....	213
Preparation of Drilling Specifications and Format .....	223
Chapter 9 Groundwater Data Acquisition	
Methods .....	227
Introduction .....	227
Design and Installation of Observation Wells and Piezometers .....	229
Methods Used to Measure Groundwater Levels .....	235
Methods and Techniques Used to Estimate Flows from Seeps, Springs, and Small Drainages .....	241
Computer-Based Monitoring Systems .....	242
Definitions .....	245
References .....	246
Bibliography .....	247

## FIELD MANUAL

Chapter 10 Guidelines for Core Logging .	249
General . . . . .	249
Format and Required Data for the Final Geologic Log . . . . .	252
Method of Reporting Orientation of Planar Discontinuities and Structural Features .	284
Core Recovery and Core Losses . . . . .	285
Samples . . . . .	287
Core Photography . . . . .	288
Equipment Necessary for Preparing Field Logs . . . . .	291
Instruction to Drillers, Daily Drill Reports, and General Drilling Procedures . . . . .	294
Chapter 11 Instructions for Logging Soils	313
General . . . . .	313
Formats for Test Pits and Auger Hole Logs	325
Format of Word Descriptions for Drill Hole Logs . . . . .	333
Exceptions to Test Pit and Auger Hole Format and Descriptions for Drill Hole Logs . . . . .	339
Equipment Necessary for Preparing the Field Log . . . . .	347
Example Descriptions and Format . . . . .	349
Laboratory Classifications in Addition to Visual Classifications . . . . .	349
Word Descriptions for Various Soil Classifications . . . . .	351
Reporting Laboratory Data . . . . .	351
Special Cases for USCS Classification . . . . .	363
Reporting In-Place Density Tests . . . . .	364
Bibliography . . . . .	366

## CONTENTS

	<i>Page</i>
Chapter 12 Hazardous Waste Site	
Investigations .....	367
General .....	367
Common Terminology and Processes .....	368
Documentation .....	369
Contaminant Characteristics and Migration .....	375
Classification and Handling of Materials ..	381
Field Sampling Protocol .....	383
Sample Analysis .....	402
Safety at Hazardous Waste Sites .....	405
Sample Quality Assurance and Quality Control .....	406
Sample Management .....	410
Decontamination .....	417
Appendix	
Abbreviations and Acronyms Commonly Used in Bureau of Reclamation Engineering Geology and Related to Hazardous Waste .....	419
Index .....	433

## TABLES

<i>Table</i>		<i>Page</i>
2-1	Ground behavior for earth tunneling with steel supports .....	10
2-2	Useful conversion factors– metric and English units (inch-pound) .....	14
3-1	Basic group names, primary groups ...	26

# FIELD MANUAL

## TABLES (continued)

<i>Table</i>		<i>Page</i>
3-2	Basic group names, 5 to 12 percent fines . . . . .	26
3-3	Criteria for describing dry strength . . .	31
3-4	Criteria for describing dilatancy . . . . .	32
3-5	Criteria for describing toughness . . . . .	33
3-6	Criteria for describing plasticity . . . . .	34
3-7	Identification of inorganic fine-grained soils from manual tests . . . . .	36
3-8	Criteria for describing angularity of coarse-grained particles . . . . .	41
3-9	Criteria for describing particle shape . .	42
3-10	Criteria for describing moisture condition . . . . .	43
3-11	Criteria for describing reaction with HCl . . . . .	43
3-12	Criteria for describing consistency of in-place or undisturbed fine-grained soils . . . . .	44
3-13	Criteria for describing cementation . . .	44
3-14	Criteria for describing structure . . . . .	45
3-15	Particle sizes . . . . .	46
3-16	Checklist for the description of soil classification and identification . . . . .	48
3-17	Checklist for the description of in-place conditions . . . . .	49
4-1	Igneous and metamorphic rock grain size descriptors . . . . .	70
4-2	Sedimentary and pyroclastic rock particle-size descriptors . . . . .	71
4-3	Bedding, foliation, or flow texture descriptors . . . . .	74
4-4	Weathering descriptors . . . . .	77
4-5	Durability index descriptors . . . . .	79

## CONTENTS

### TABLES (continued)

<i>Table</i>		<i>Page</i>
4-6	Rock hardness/strength descriptors . . .	83
5-1	Fracture density descriptors . . . . .	97
5-2	Fracture spacing descriptors . . . . .	102
5-3	Fracture continuity descriptors . . . . .	102
5-4	Descriptors for recording fracture ends in joint surveys . . . . .	103
5-5	Fracture openness descriptors . . . . .	104
5-6	Fracture filling thickness descriptors . .	104
5-7	Fracture healing descriptors . . . . .	107
5-8	Fracture roughness descriptors . . . . .	109
5-9	Fracture moisture conditions descriptors . . . . .	110
6-1	U.S. State plane coordinate systems – 1927 datum . . . . .	137
6-2	U.S. State plane coordinate systems – 1983 datum . . . . .	143
11-1	Checklist for the description of soils in test pit and auger hole logs . . . . .	326
12-1	EPA recommended sampling containers, preservation requirements, and holding times for soil samples . . . . .	385
12-2	Summary of soil sampling devices . . . .	388
12-3	Common laboratory testing methods . .	404

### FIGURES

<i>Figure</i>		<i>Page</i>
3-1	Modifiers to basic soil group names . . .	22
3-2	Flow chart for inorganic fine-grained soils, visual method . . . . .	23

# FIELD MANUAL

## FIGURES (continued)

<i>Figure</i>		<i>Page</i>
3-3	Flow chart for organic soils, visual method . . . . .	24
3-4	Flow chart for coarse-grained soils, visual method . . . . .	25
3-5	Plasticity chart . . . . .	35
3-6	Sample of test results summary . . . . .	53
4-1	Field classification of igneous rocks . . .	60
4-2	Field classification of sedimentary rocks . . . . .	61
4-3	Field classification of metamorphic rocks . . . . .	62
4-4	Field classification of pyroclastic rocks .	63
4-5	Charts for estimating percentage of composition of rocks and sediments .	64
4-6	Descriptor legend and explanation example . . . . .	67
4-7	Permeability conversion chart . . . . .	87
5-1	Rock Quality Designation (RQD) computation . . . . .	96
5-2	Comparison of true and apparent spacing . . . . .	101
5-3	Examples of roughness and waviness of fracture surfaces, typical roughness profiles, and terminology . . . . .	108
5-4	Uniform shear zone . . . . .	115
5-5	Structured shear zone (two zones or layers) . . . . .	116
5-6	Structured shear zone (three layers) ..	116
5-7	Uniform shear zone with veinlets . . . . .	116
5-8	Uniform shear zone (composite) . . . . .	117
5-9	Standard descriptors and descriptive criteria for discontinuities . . . . .	121

# CONTENTS

## FIGURES (continued)

<i>Figure</i>		<i>Page</i>
6-1	Process of engineering geology mapping . . . . .	131
6-2	Sample trench log . . . . .	160
6-3	Sample completed trench log . . . . .	165
6-4	Tunnel mapping form with key alphanumeric descriptors and mapping data . . . . .	173
6-5	Tunnel mapping form with blocks for title and geologic data . . . . .	174
6-6	As-built summary geology tunnel map .	179
6-7	Full periphery mapping method layout . . . . .	186
6-8	Full periphery geologic map example . .	188
6-9	Map layout of a tunnel for geologic mapping . . . . .	191
6-10	Relationship of planar feature trace to map projections . . . . .	192
7-1	Equatorial equal area net . . . . .	209
7-2	Discontinuity log field sheet . . . . .	210
10-1	Drill hole log, DH-123 . . . . .	253
10-2	Drill hole log, B-102, for Standard Penetration Test . . . . .	255
10-3	Drill hole log, DH-SP-2 . . . . .	259
10-4	Drill hole log, SPT-107-2 . . . . .	261
10-5	Drill hole log, DH-DN/P-60-1 . . . . .	270
10-6	Daily drill report . . . . .	292
10-7	Water testing record . . . . .	299
10-8	Use of half-round to protect core . . . . .	301
10-9	Standard N-size core box . . . . .	303
10-10	Log of concrete and rock core . . . . .	308
11-1	Log of test pit or auger hole . . . . .	314
11-2	Clean coarse-grained soils . . . . .	315

# FIELD MANUAL

## FIGURES (continued)

<i>Figure</i>		<i>Page</i>
11-3	Fine-grained soils . . . . .	316
11-4	Soil classifications based on laboratory test data . . . . .	317
11-5	Auger hole with samples taken . . . . .	318
11-6	Reporting laboratory classification in addition to visual classification . . . . .	319
11-7	Undisturbed soils . . . . .	320
11-8	Coarse-grained soils with fines . . . . .	321
11-9	Coarse-grained soils with dual symbols . . . . .	322
11-10	Reporting in-place density tests and percent compaction . . . . .	323
11-11	Soil with measured percentages of cobble and boulders . . . . .	324
11-12	Field form - soil logging . . . . .	329
11-13	Soil with more than 50 percent cobble and boulders . . . . .	334
11-14	Borderline soils . . . . .	335
11-15	Test pit with samples taken . . . . .	336
11-16	Disturbed samples . . . . .	337
11-17	Two descriptions from the same horizon . . . . .	338
11-18	Drill hole advanced by tri-cone rock bit . . . . .	340
11-19	Log showing poor recovery . . . . .	342
11-20	Log of landslide material (a) . . . . .	343
11-21	Log of landslide material (b) . . . . .	344
11-22	Log of bedrock . . . . .	345
11-23	Geologic interpretation in test pit (sheet 1) . . . . .	350
11-24	Geologic interpretation in test pit (sheet 2) . . . . .	352



# CONTENTS

## FIGURES (continued)

<i>Figure</i>		<i>Page</i>
11-25	Geologic interpretation in test pit using a geologic profile (1) . . . . .	353
11-26	Geologic interpretation in test pit (sheet 3) . . . . .	354
11-27	Geologic interpretation in test pit (sheet 4) . . . . .	355
11-28	Geologic interpretation in test pit using a geologic profile (2) . . . . .	356
11-29	Geologic interpretation in test pit (sheet 5) . . . . .	357
11-30	Geologic interpretation in test pit (sheet 6) . . . . .	358
11-31	Geologic interpretation in test pit (sheet 7) . . . . .	359
11-32	Geologic interpretation in test pit (sheet 8) . . . . .	360
11-33	Geologic interpretation in test pit using a geologic profile (3) . . . . .	361
12-1	Aquifer types . . . . .	379
12-2	Typical monitoring well construction for water quality sampling . . . . .	399
12-3	Soil and water sample identification labels . . . . .	412
12-4	Chain-of-custody record . . . . .	413
12-5	Custody seal . . . . .	415



# Chapter 1

## INTRODUCTION

This manual provides guidelines and instructions for performing and documenting field work. The manual is a ready reference for anyone engaged in field-oriented engineering geology or geotechnical engineering. The manual is written for general engineering geology use as well as to meet Reclamation needs. The application of geology to solving engineering problems is emphasized, rather than academic or other aspects of geology. The manual provides guidance for:

- Geologic classification and description of rock and rock discontinuities
- Engineering classification and description of soil and surficial deposits
- Application of standard indexes, descriptors, and terminology
- Geologic mapping, sampling, testing, and performing discontinuity surveys
- Exploratory drilling
- Soil and rock logging
- Acquisition of groundwater data
- Core logging
- Soil logging
- Investigation of hazardous waste sites

## FIELD MANUAL

Although the methods described in this manual are appropriate for most situations, complex sites, conditions, or design needs may require modification or expansion of the suggestions, criteria, and indices to fit specific requirements.

Many of the chapters in this manual will always need revision because they cover material that changes as technology changes. Critical comments, especially suggestions for improvement, are welcome from all users, not just the Bureau of Reclamation.

The appendix contains abbreviations and acronyms commonly used in engineering geology.

## Chapter 2

# GEOLOGIC TERMINOLOGY AND CLASSIFICATIONS FOR GEOLOGIC MATERIALS

### Established References for Geological Terminology

Adaptations or refinements of the Bureau of Reclamation (Reclamation) standards presented in this and subsequent chapters may be established to meet specific design requirements or site-specific geologic complexity when justified.

The *Glossary of Geology*, Fourth Edition [1]<sup>1</sup>, published by the American Geological Institute (AGI), 1997, is accepted by Reclamation as the standard for definitions of geologic words and terms except for the nomenclature, definitions, or usage established in this chapter and chapters 3, 4, and 5.

The North American Stratigraphic Code (NASC) [2] is the accepted system for classifying and naming stratigraphic units. However, Reclamation's engineering geology programs are focused primarily on the engineering properties of geologic units, not on the details of formal stratigraphic classification. Stratigraphic names are not always consistent within the literature, often change from one locality to another, and do not necessarily convey engineering properties or rock types. Use of stratigraphic names in Reclamation documents normally will be informal (lower case) (see NASC for discussion of formal versus informal usage). Exceptions to informal usage are for names previously used formally in the area in discussions of geologic setting or regional geology. Normally,

---

<sup>1</sup> Brackets refer to bibliography entries at end of each chapter.

## FIELD MANUAL

the first use of formal names in a report should include a reference to a geologic map or publication in which the term is defined.

### Geologic Classification of Materials

The following definitions of geologic materials more fully satisfy general usage and supersede those in the *Glossary of Geology*. These definitions are for geologic classification of materials. They should not be confused with engineering classifications of materials such as rock and soil or rock and common excavation.

- **Bedrock** is a general term that includes any of the generally indurated or crystalline materials that make up the Earth's crust. Individual stratigraphic units or units significant to engineering geology within bedrock may include poorly or nonindurated materials such as beds, lenses, or intercalations. These may be weak rock units or interbeds consisting of clay, silt, and sand (such as the generally soft and friable St. Peter Sandstone), or clay beds and bentonite partings in siliceous shales of the Morrison Formation.

- **Surficial Deposits** are the relatively younger materials occurring at or near the Earth's surface overlying bedrock. They occur as two major classes: (1) transported deposits generally derived from bedrock materials by water, wind, ice, gravity, and man's intervention and (2) residual deposits formed in place as a result of weathering processes. Surficial deposits may be stratified or unstratified such as soil profiles, basin fill, alluvial or fluvial deposits, landslides, or talus. The material may be partially indurated or cemented by silicates, oxides, carbonates, or other chemicals (caliche or hardpan). This term is often used interchangeably with the imprecisely

## TERMINOLOGY

defined word “overburden.” “Overburden” is a mining term meaning, among other things, material overlying a useful material that has to be removed. “Surficial deposit” is the preferred term.

In some localities, where the distinction between bedrock and surficial deposits is not clear, even if assigned a stratigraphic name, a uniform practice should be established and documented and that definition followed for the site or study.

Guidelines for the collection of data pertaining to bedrock and surficial deposits are presented in chapter 6.

### **Engineering Classification of Geologic Materials**

#### **General**

Geologic classification of materials as surficial deposits or bedrock is insufficient for engineering purposes. Usually, surficial deposits are described as soil for engineering purposes, and most bedrock is described as rock; however, there are exceptions. Contract documents often classify structure excavations as to their ease of excavation. Also, classification systems for tunneling in geologic materials have been established.

#### **Classification as Soil or Rock**

In engineering applications, **soil** may be defined as generally unindurated accumulations of solid particles produced by the physical and/or chemical disintegration of bedrock and which may or may not contain organic matter. Surficial deposits, such as colluvium, alluvium, or residual soil, normally are described using Recla-

## FIELD MANUAL

mation Procedure 5005, Determining Unified Soil Classification (Visual Method) [3]. American Society for Testing and Materials (ASTM) Standards D2487-85, Standard Test Method for Classification of Soils for Engineering Purposes or D2488-84, Standard Practice for Description and Identification of Soils (Visual-Manual Procedure), which are based on Reclamation 5000 and 5005 [3] also may be used. Instructions for the description and classification of soils are provided in chapter 3. Chapter 11 provides instructions for the logging of soils in geologic explorations. In some cases, partially indurated soils may have rock-like characteristics and may be described as rock.

The United States Department of Agriculture (USDA) Agricultural Soils Classification System is used for drainage and land classification and some detailed Quaternary geology studies, such as for seismotectonic investigations.

*Rock* as an engineering material is defined as lithified or indurated crystalline or noncrystalline materials. Rock is encountered in masses and as large fragments which have consequences to design and construction differing from those of soil. Field classification of igneous, metamorphic, sedimentary, and pyroclastic rocks are provided in chapter 4. Chapter 4 also presents a suggested description format, standard descriptors, and descriptive criteria for the lithologic and engineering physical properties of rock. Nonindurated materials within bedrock should be described using the Reclamation soil classification standards and soil descriptors presented in chapter 3. Engineering and geological classification and description of discontinuities which may be present in either soil or rock are discussed in chapter 5.



## TERMINOLOGY

### Classification of Excavations

The engineering classification of excavation as either rock excavation or common excavation or the definition of rock in specifications must be evaluated and determined for each contract document and should be based on the physical properties of the materials (induration and other characteristics), quantity and method of excavation, and equipment constraints and size.

### Classification of Materials for Tunneling

Classification systems are used for data reports, specifications, and construction monitoring for tunnel designs and construction. When appropriate for design, other load prediction and classification systems may be used such as the Q system developed by the Norwegian Geotechnical Institute (NGI), Rock Mass Rating System Geomechanics Classification (RMR), and Rock Structure Rating (RSR).

The following terms for the classification of rock [4] for tunneling are suggested:

- **Intact rock** contains neither joints nor hairline cracks. If it breaks, it breaks across sound rock. On account of damage to the rock due to blasting, spalls may drop off the roof several hours or days after blasting. This is known as spalling condition. Hard, intact rock may also be encountered in the popping condition (rock burst) involving the spontaneous and violent detachment of rock slabs from sides or roof.
- **Stratified rock** consists of individual strata with little or no resistance against separation along the boundaries

## FIELD MANUAL

between strata. The strata may or may not be weakened by transverse joints. In such rock, the spalling condition is quite common.

- **Moderately jointed rock** contains joints and hairline cracks, but the blocks between joints are locally grown together or so intimately interlocked that vertical walls do not require lateral support. In rocks of this type, both the spalling and the popping condition may be encountered.

- **Blocky and seamy rock** consists of chemically intact or almost intact rock fragments which are entirely separated from each other and imperfectly interlocked. In such rock, vertical walls may require support.

- **Crushed but chemically intact rock** has the character of a crusher run. If most or all of the fragments are as small as fine sand and no recementation has taken place, crushed rock below the water table exhibits the properties of a water-bearing sand.

- **Squeezing rock** slowly advances into the tunnel without perceptible volume increase. Movement is the result of overstressing and plastic failure of the rock mass and not due to swelling.

- **Swelling rock** advances into the tunnel chiefly on account of expansion. The capacity to swell is generally limited to those rocks which contain smectite, a montmorillonite group of clay minerals, with a high swelling capacity.

Although the terms are defined, no distinct boundaries exist between rock categories. Wide variations in the physical properties of rocks classified by these terms and rock loading are often the case.

## TERMINOLOGY

Table 2-1, Ground behavior for earth tunneling with steel supports, provides ground classifications for different reactions of ground to tunneling operations.

### **Application and Use of Standard Indexes, Terminology, and Descriptors**

This section and subsequent chapters 3, 4, and 5 provide definitions and standard descriptors for physical properties of geologic materials which are of engineering significance. The ability of a foundation to support loads imposed by various structures depends primarily on the deformability and stability of the foundation materials and the groundwater conditions. Description of geologic and some manmade materials (embankments) is one of the geologist's direct contributions to the design process. Judgment and intuition alone are not adequate for the safe and economical design of large complex engineering projects. Preparation of geologic logs, maps and sections, and detailed descriptions of observed material is the least expensive aspect and most continuous record of a sub-surface exploration program. It is imperative to develop design data properly because recent advances in soil and rock mechanics have enabled engineers and geologists to analyze more conditions than previously possible. These analyses rely on physical models that are developed through geologic observation and which must be described without ambiguity.

The need for standard geologic terminology, indexes, and descriptors has long been recognized because it is important that design engineers and contractors, as well as geologists, be able to have all the facts and qualitative information as a common basis to arrive at conclusions from any log of exploration, report, or drawing, regardless of the preparer. Geologic terminology,

## FIELD MANUAL

Table 2-1.—Ground behavior for earth tunneling with steel supports (after Terzaghi, 1977) [4]

Ground classification	Reaction of ground to tunneling operation
HARD	Tunnel heading may be advanced without roof support.
FIRM	Ground in which a roof section of a tunnel can be left unsupported for several days without inducing a perceptible movement of the ground.
RAVELING	Chunks or flakes of soil begin to drop out of roof at some point during the ground-movement period.
SLOW RAVELING	The time required to excavate 5 feet of tunnel and install a rib set and lagging in a small tunnel is about 6 hours. Therefore, if the stand-up time of raveling ground is more than 6 hours, by using ribs and lagging, the steel rib sets may be spaced on 5-foot centers. Such a soil would be classed as slow raveling.
FAST RAVELING	If the stand-up time is less than 6 hours, set spacing must be reduced to 4 feet, 3 feet, or even 2 feet. If the stand-up time is too short for these smaller spacings, liner plates should be used, either with or without rib sets, depending on the tunnel size.
SQUEEZING	Ground slowly advances into tunnel without any signs of fracturing. The loss of ground caused by squeeze and the resulting settlement of the ground surface can be substantial.
SWELLING	Ground slowly advances into the tunnel partly or chiefly because of an increase in the volume of the ground. The volume increase is in response to an increase of water content. In every other respect, swelling ground in a tunnel behaves like a stiff non-squeezing, or slowly squeezing, non-swelling clay.
RUNNING	The removal of lateral support on any surface rising at an angle of more than $34^{\circ}$ (to the horizontal) is immediately followed by a running movement of the soil particles. This movement does not stop until the slope of the moving soil becomes roughly equal to $34^{\circ}$ if running ground has a trace of cohesion, then the run is preceded by a brief period of progressive raveling.
VERY SOFT SQUEEZING	Ground advances rapidly into tunnel in a plastic flow.
FLOWING	Ground supporting a tunnel cannot be classified as flowing ground unless water flows or seeps through it toward the tunnel. For this reason, a flowing condition is encountered only in free air tunnels below the watertable or under compressed air when the pressure is not high enough in the tunnel to dry the bottom. A second prerequisite for flowing is low cohesion of soil. Therefore, conditions for flowing ground occur only in inorganic silt, fine silty sand, clean sand or gravel, or sand-and-gravel with some clay binder. Organic silt may behave either as a flowing or as a very soft, squeezing ground.

## TERMINOLOGY

standard descriptors, and descriptive criteria for physical properties have been established so that geologic data are recorded uniformly, objectively, consistently, and accurately. The application of these indexes, terminology, descriptors, and various manual and visual tests must be applied consistently by all geologists for each particular project. The need to calibrate themselves with others performing similar tests and descriptions is imperative to ensure that data are recorded and interpreted uniformly. The use of these standard descriptors and terminology is not intended to replace the geologist's or engineer's individual judgment. The established standard qualitative and quantitative descriptors will assist newly employed geologists and engineers in understanding Reclamation terminology and procedures, permit better analysis of data, and permit better understanding by other geologists and engineers, and by contractors. Most of the physical dimensions established for the descriptive criteria pertaining to rock and discontinuity characteristics have been established using a 1-3-10-30-100 progression for consistency, ease of memory, conversion from English to metric (30 millimeters [mm] = 0.1 foot [ft]) units, and to conform to many established standards used throughout the world. Their use will improve analysis, design and construction considerations, and specifications preparation. Contractor claims also should be reduced due to consistent and well defined terminology and descriptors.

Alphanumeric values for many physical properties have been established to enable the geotechnical engineer and engineering geologist to readily analyze the geologic data. These alphanumeric descriptors also will assist in compilation of data bases and computer searches when using computer generated logs. For consistency, the lower the alphanumeric value, the more favorable the condition being described. However, alphanumeric codes do not replace a complete description of what is observed. A

## FIELD MANUAL

complete description provides physical dimensions including a range and/or average in size, width, length or other physical property, and/or descriptive information.

It is important to start physical testing of the geologic materials as early as possible in an exploration program; descriptors alone are not sufficient. As data are interpreted, index properties tests can be performed in the field to obtain preliminary strength estimates for representative materials or materials requiring special consideration. The scope of such a program must be tailored to each feature. Tests which are to be considered include point load, Schmidt hammer, sliding tilt, and pocket Torvane or penetrometer tests. These tests are described briefly in chapters 4 and 5. Indexes to be considered include rock hardness, durability (slaking), and Rock Quality Designation (RQD). The type of detailed laboratory studies can be formulated better and the amount of sampling and testing may be reduced if results from field tests are available.

### **Units of Measurements for Geologic Logs of Exploration, Drawings, and Reports**

#### **Metric Units**

For metric specifications and studies, metric (International System of Units) should be used from the start of work if possible. Logs of exploration providing depth measurements should be given to tenths or hundredths of meters. All linear measurements such as particle or crystal sizes, ranges or averages in thickness, openness, and spacing, provided in descriptor definitions in chapters 3, 4, and 5, should be expressed in millimeters or meters as appropriate. Pressures should be given in pascals (Pa). Permeability (hydraulic conductivity)

## TERMINOLOGY

should be in centimeters per second (cm/s). In some cases, local usage of other units such as kilogram per square centimeter ( $\text{kg}/\text{cm}^2$ ) for pressure or centimeters (cm) may be used.

### **English Units (U.S. Customary)**

For specifications and studies using United States customary or English units (inch-pound), depth measurements should be given in feet and tenths of feet. Ranges in thickness, openness, and spacing, are preferred in tenths or hundredths of a foot, or feet as shown in the descriptor definitions in chapters 4 and 5. Pressure should be in pound-force per square inch ( $\text{lbf}/\text{in}^2$  or PSI). Permeability should be in feet per year (ft/yr). The exceptions to the use of English units (inch-pound) are for describing particle and grain sizes and age dating. Particle sizes for soils classified using American Society for Testing and Materials/Unified Soil Classification Systems (ASTM/USCS) should be in metric units on all logs of exploration. For description of bedrock, particle and grain sizes are to be in millimeters.

### **Age Dates**

If age dates are abbreviated, the North American Stratigraphic Commission (NASC) recommends *ka* for thousand years and *Ma* for million years, but *my* or *m.y.* (million years) for time intervals (for example, ". . . during a period of 40 my . . .").

### **Conversion of Metric and English (U.S. Customary) Units**

Table 2-2 provides many of the most frequently used metric and English (U.S. Customary) units for geotechnical work.

# FIELD MANUAL

Table 2-2.—Useful conversion factors—metric and English units (inch-pound)

Column 1	Column 2	Column 3	Column 4
<b>To convert units in column 1 to units in column 4, multiply column 1 by the factor in column 2.</b>			
<b>To convert units in column 4 to units in column 1, multiply column 4 by the factor in column 3.</b>			
Column 1	Column 2	Column 3	Column 4
<b>Length</b>			
inch (in)	2.540 X 10 <sup>1</sup>	3.937 X 10 <sup>2</sup>	millimeter (mm)
hundredths of feet	3.048 X 10 <sup>2</sup>	3.281 X 10 <sup>-3</sup>	millimeter (mm)
foot (ft)	3.048 X 10 <sup>-1</sup>	3.281	meter (m)
mile (mi)	1.6093	6.2137 X 10 <sup>-1</sup>	kilometer (km)
<b>Area</b>			
square inch (in <sup>2</sup> )	6.4516 X 10 <sup>-4</sup>	1.550 X 10 <sup>-3</sup>	square meter (m <sup>2</sup> )
square foot (ft <sup>2</sup> )	9.2903 X 10 <sup>-2</sup>	1.0764 X 10 <sup>1</sup>	square meter (m <sup>2</sup> )
acre	4.0469 X 10 <sup>-1</sup>	2.4711	hectare
square mile (mi <sup>2</sup> )	0.386 X 10 <sup>-2</sup>	259.0	hectares
<b>Volume</b>			
cubic inch (in <sup>3</sup> )	1.6387 X 10 <sup>2</sup>	6.102 X 10 <sup>2</sup>	cubic centimeter (cm <sup>3</sup> )
cubic feet (ft <sup>3</sup> )	2.8317 X 10 <sup>2</sup>	3.5315 x 10 <sup>1</sup>	cubic meter (m <sup>3</sup> )
cubic yard (yd <sup>3</sup> )	7.6455 X 10 <sup>1</sup>	1.3079	cubic meter (m <sup>3</sup> )
cubic feet (ft <sup>3</sup> )	7.4805	1.3368 x 10 <sup>-1</sup>	gallon (gal)
gallon (gal)	3.7854	2.6417 X 10 <sup>-1</sup>	liter (L)
acre-feet (acre-ft)	1.2335 X 10 <sup>3</sup>	8.1071 X 10 <sup>-4</sup>	cubic meter (m <sup>3</sup> )
<b>Flow</b>			
gallon per minute (gal/min)	6.309 X 10 <sup>-2</sup>	1.5850 X 10 <sup>1</sup>	liter per second (L/s)
cubic foot per second (ft <sup>3</sup> /s)	4.4883 X 10 <sup>2</sup>	2.228 X 10 <sup>-3</sup>	gallons per minute (gal/min)
	1.9835	5.0417 X 10 <sup>-1</sup>	acre-feet per day (acre-ft/d)
cubic foot per second (ft <sup>3</sup> /s)	7.2398 X 10 <sup>2</sup>	1.3813 X 10 <sup>-3</sup>	acre-feet per year (acre-ft/yr)
	2.8317 X 10 <sup>2</sup>	3.531 X 10 <sup>1</sup>	cubic meters per second (m <sup>3</sup> /s)
	8.93 X 10 <sup>5</sup>	1.119 X 10 <sup>-6</sup>	cubic meters per year (m <sup>3</sup> /yr)
<b>Permeability</b>			
<i>k</i> , feet/year	9.651 X 10 <sup>-7</sup>	1.035 X 10 <sup>6</sup>	<i>k</i> , centimeter per second (cm/sec)
<b>Density</b>			
pound-mass per cubic foot (lb/ft <sup>3</sup> )	1.6018 X 10 <sup>1</sup>	6.2429 X 10 <sup>2</sup>	kilogram per cubic meter (kg/m <sup>3</sup> )
<b>Unit Weight</b>			
pound force per cubic foot (lb/ft <sup>3</sup> )	0.157	6.366	kilonewton per cubic meter (kN/m <sup>3</sup> )
<b>Pressure</b>			
pounds per square inch (psi)	7.03 X 10 <sup>-2</sup>	1.4223 X 10 <sup>1</sup>	kilogram per square centimeter (kg/cm <sup>2</sup> )
	6.8948	0.145	kiloPascal (kPa)
<b>Force</b>			
ton	8.89644	1.12405 X 10 <sup>-1</sup>	kilonewton (kN)
pound-force	4.4482 X 10 <sup>-3</sup>	224.8096	kilonewton (kN)
<b>Temperature</b>			
	EC = 5/9 (EF - 32 E)		EF = (9/5 EC) + 32 E
<b>Grouting</b>			
Metric bag cement per meter	3.0	0.33	U.S. bag cement per foot
Water:cement ratio by volume	0.7	1.4	water:cement ratio by weight
pounds per square inch per foot	0.2296	4.3554	kilogram per square centimeter per meter (kg/cm <sup>2</sup> /m)
<i>k</i> , feet/year	0.1	10	Lugeon



## TERMINOLOGY

### BIBLIOGRAPHY

- [1] *The Glossary of Geology*, 4th edition, American Geologic Institute, Alexandria, VA, 1997.
- [2] The American Association of Petroleum Geologists Bulletin, v. 67, No. 5, pp. 841-875, May 1983.
- [3] Bureau of Reclamation, *Earth Manual*, 3rd edition, part 2, Denver, CO, 1990.
- [4] Proctor, Robert V., and Thomas L. White, "Earth Tunneling with Steel Supports," Commercial Shearing, Inc., 1775 Logan Avenue, Youngstown, OH 44501, 1977.



## Chapter 3

# ENGINEERING CLASSIFICATION AND DESCRIPTION OF SOIL

### General

#### Application

Soil investigations conducted for engineering purposes that use test pits, trenches, auger and drill holes, or other exploratory methods and surface sampling and mapping are logged and described according to the Unified Soil Classification System (USCS) as presented in Bureau of Reclamation (Reclamation) standards USBR 5000 [1] and 5005 [2]. Also, bedrock materials with the engineering properties of soils are described using these standards (chapter 2). The Reclamation standards are consistent with the American Society for Testing Materials (ASTM) Designation D2487 and 2488 on the USCS system [3,4]. Descriptive criteria and terminology presented are primarily for the visual classification and manual tests. The identification portion of these methods in assigning group symbols is limited to soil particles smaller than 3 inches (in) (75 millimeters [mm]) and to naturally occurring soils. Provisions are also made to estimate the percentages of cobbles and boulders by volume. This descriptive system may also be applied to shale, shells, crushed rock, and other materials if done according to criteria established in this section. Chapter 11 addresses the logging format and criteria for describing soil in test pits, trenches, auger holes, and drill hole logs.

All investigations associated with land classification for irrigation suitability, data collection, analyses of soil and substratum materials related to drainage investigations, and Quaternary stratigraphy (e.g., fault and paleoflood studies) are logged and described using the

## FIELD MANUAL

U.S. Department of Agriculture terminology outlined in appendix I to *Agriculture Handbook No. 436 (Soil Taxonomy)*, dated December 1975 [5].

All soil classification descriptions for particle sizes less than No. 4 sieve size are to be in metric units.

### Performing Tests and Obtaining Descriptive Information

The USCS groups soils according to potential engineering behavior. The descriptive information assists with estimating engineering properties such as shear strength, compressibility, and permeability. These guidelines can be used not only for identification of soils in the field but also in the office, laboratory, or wherever soil samples are inspected and described.

Laboratory classification of soils [1] is not always required but should be performed as necessary and can be used as a check of visual-manual methods. The descriptors obtained from visual-manual inspection provide valuable information not obtainable from laboratory testing. Visual-manual inspection is always required. The visual-manual method has particular value in identifying and grouping similar soil samples so that only a minimum number of laboratory tests are required for positive soil classification. The ability to identify and describe soils correctly is learned more readily under the guidance of experienced personnel, but can be acquired by comparing laboratory test results for typical soils of each type with their visual and manual characteristics. When identifying and describing soil samples from an area or project, all the procedures need not be followed. Similar soils may be grouped together; for example, one sample should be identified and described completely, with the others identified as similar based on performing only a few of the identification and descriptive procedures.

## SOIL

Descriptive information should be evaluated and reported on every sample.

The sample used for classification must be representative of the stratum and be obtained by an appropriate accepted or standard procedure. The origin of the material must be correctly identified. The origin description may be a boring number and depth and/or sample number, a geologic stratum, a pedologic horizon, or a location description with respect to a permanent monument, a grid system, or a station number and offset.

### Terminology for Soils

Definitions for soil classification and description are in accordance with USBR 3900 Standard Definitions of Terms and Symbols Relating to Soil Mechanics [6]:

Cobbles and boulders—particles retained on a 3-inch (75-mm) U.S. Standard sieve. The following terminology distinguishes between cobbles and boulders:

- Cobbles—particles of rock that will pass a 12-in (300-mm) square opening and be retained on a 3-in (75-mm) sieve.
- Boulders—particles of rock that will not pass a 12-in (300-mm) square opening.

Gravel—particles of rock that will pass a 3-in (75-mm) sieve and is retained on a No. 4 (4.75-mm) sieve. Gravel is further subdivided as follows:

- Coarse gravel—passes a 3-in (75-mm) sieve and is retained on 3/4-in (19-mm) sieve.
- Fine gravel—passes a 3/4-in (19-mm) sieve and is retained on No. 4 (4.75-mm) sieve.

## FIELD MANUAL

**Sand**—particles of rock that will pass a No. 4 (4.75-mm) sieve and is retained on a No. 200 (0.075-mm or 75-micrometer [ $\mu\text{m}$ ]) sieve. Sand is further subdivided as follows:

- Coarse sand—passes No. 4 (4.75-mm) sieve and is retained on No. 10 (2.00-mm) sieve.
- Medium sand—passes No. 10 (2.00-mm) sieve and is retained on No. 40 (425- $\mu\text{m}$ ) sieve.
- Fine sand—passes No. 40 (425- $\mu\text{m}$ ) sieve and is retained on No. 200 (0.075-mm or 75- $\mu\text{m}$ ) sieve.

**Clay**—passes a No. 200 (0.075-mm or 75- $\mu\text{m}$ ) sieve. Soil has plasticity within a range of water contents and has considerable strength when air-dry. For classification, clay is a fine-grained soil, or the fine-grained portion of a soil, with a plasticity index greater than 4 and the plot of plasticity index versus liquid limit falls on or above the "A"-line (figure 3-5, later in this chapter).

**Silt**—passes a No. 200 (0.075-mm or 75- $\mu\text{m}$ ) sieve. Soil is nonplastic or very slightly plastic and that exhibits little or no strength when air-dry is a silt. For classification, a silt is a fine-grained soil, or the fine-grained portion of a soil, with a plasticity index less than 4 or the plot of plasticity index versus liquid limit falls below the "A"-line (figure 3-5).

**Organic clay**—clay with sufficient organic content to influence the soil properties is an organic clay. For classification, an organic clay is a soil that would be classified as a clay except that its liquid limit value after oven-drying is less than 75 percent of its liquid limit value before oven-drying.

## SOIL

Organic silt—silt with sufficient organic content to influence the soil properties. For classification, an organic silt is a soil that would be classified as a silt except that its liquid limit value after oven-drying is less than 75 percent of its liquid limit value before oven-drying.

Peat—material composed primarily of vegetable tissues in various stages of decomposition, usually with an organic odor, a dark brown to black color, a spongy consistency, and a texture ranging from fibrous to amorphous. Classification procedures are not applied to peat.

### Classifications of Soils

#### Group Names and Group Symbols

The identification and naming of a soil based on results of visual and manual tests is presented in a subsequent section. Soil is given an identification by assigning a group symbol(s) and group name. Important information about the soil is added to the group name by the term "with" when appropriate (figures 3-1, 3-2, 3-3, 3-4). The group name is modified using "with" to stress other significant components in the soil.

Figure 3-2 is a flow chart for assigning typical names and group symbols for inorganic fine-grained soils; figure 3-3 is a flow chart for organic fine-grained soils; figure 3-4 is a flow chart for coarse-grained soils. Refer to tables 3-1 and 3-2 for the basic group names without modifiers. If the soil has properties which do not distinctly place it in

## FIELD MANUAL

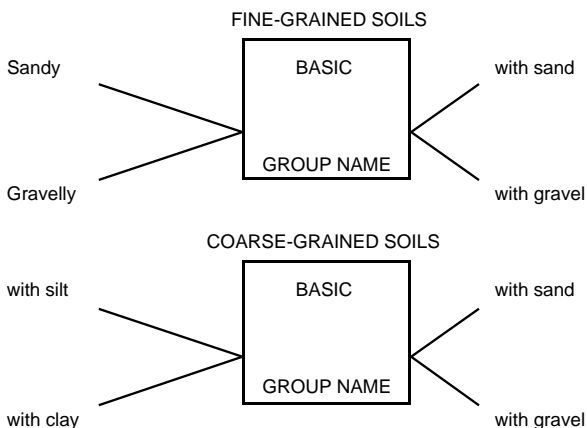


Figure 3-1.—Modifiers to basic soil group names (for visual classification).

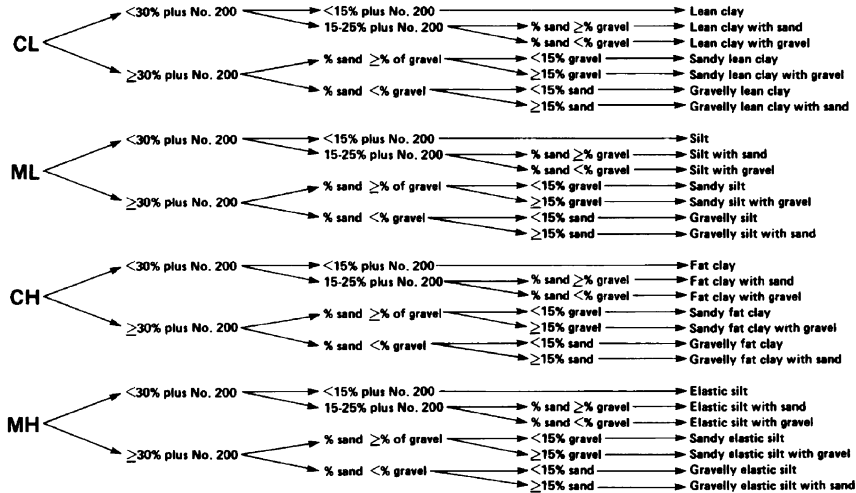
a specific group, borderline symbols may be used. There is a distinction between *dual symbols* and *borderline symbols*.

**Dual Symbols.**—Dual symbols separated by a hyphen are used in laboratory classification of soils and in visual classification when soils are estimated to contain 10 percent fines. A dual symbol (two symbols separated by a hyphen, e.g., GP-GM, SW-SC, CL-ML) should be used to indicate that the soil has the properties of a classification where two symbols are required. Dual symbols are required when the soil has between 5 and 12 percent fines from laboratory tests (table 3-2), or fines are estimated as 10 percent by visual classification. Dual symbols are also required when the liquid limit and plasticity index values plot in the CL-ML area of the plasticity chart (figure 3-5, later in this chapter).



**GROUP SYMBOL**

**GROUP NAME**



SOIL

Figure 3-2.—Flow chart for inorganic fine-grained soils, visual method.

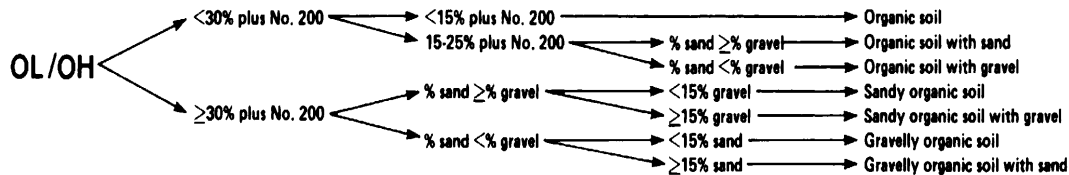
GROUP SYMBOLGROUP NAME

Figure 3-3.—Flow chart for organic soils, visual method.

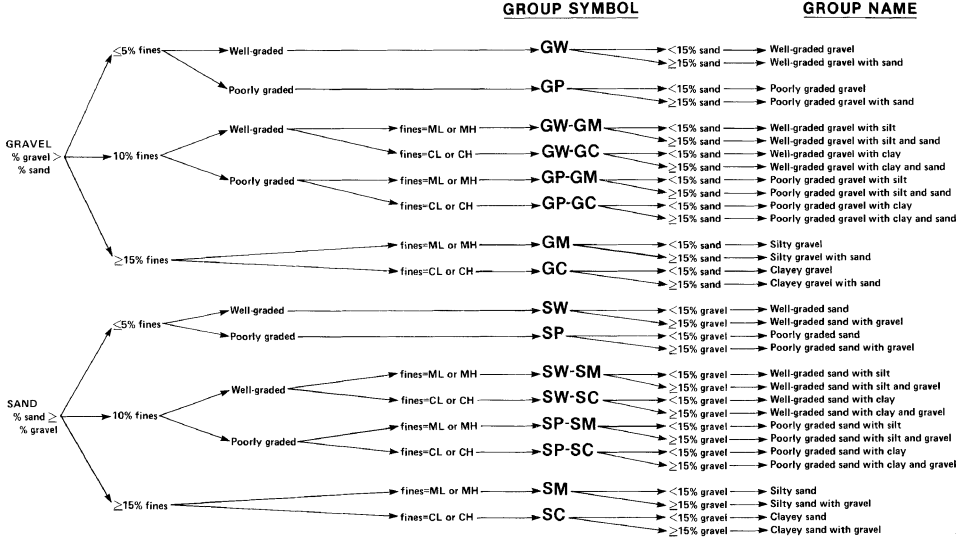


Figure 3-4.—Flow chart for coarse-grained soils, visual method.

## FIELD MANUAL

Table 3-1.—Basic group names, primary groups

Coarse-grained soils	Fine-grained soils
GW - Well graded gravel GP - Poorly graded gravel GM - Silty gravel GC - Clayey gravel sand SW - Well graded sand SP - Poorly graded sand SM - Silty sand SC - Clayey sand	CL - Lean clay ML - Silt OL - Organic clay (on or above A-line) - Organic silt (below A-line) CH - Fat clay MH - Elastic silt OH - Organic clay (on or above A-line) - Organic silt (below A-line)
Basic group name—hatched area on Plasticity Chart (Laboratory Classification)	
CL-ML - Silty clay GC-GM - Silty, clayey gravel SC-SM - Silty, clayey sand	

Table 3-2.—Basic group names, 5 to 12 percent fines  
(Laboratory Classification)

GW-GM - Well graded gravel with silt GW-GC - Well graded gravel with clay (if fines = CL-ML) Well graded gravel with silty clay GP-GM - Poorly graded gravel with silt GP-GC - Poorly graded gravel with clay (if fines = CL-ML) Poorly graded gravel with silty clay SW-SM - Well graded sand with silt SW-SC - Well graded sand with clay (if fines = CL-ML) Well graded sand with silty clay SP-SM - Poorly graded sand with silt SP-SC - Poorly graded sand with clay (if fines = CL-ML) Poorly graded sand with silty clay
--

## SOIL

**Borderline Symbols.**—Borderline symbols are used when soil properties indicate the soil is close to another classification group. Two symbols separated by a slash, such as CL/CH, SC/CL, GM/SM, CL/ML, should be used to indicate that the soil has properties that do not distinctly place the soil into a specific group. Because the visual classification of soil is based on estimates of particle-size distribution and plasticity characteristics, it may be difficult to clearly identify the soil as belonging to one category. To indicate that the soil may fall into one of two possible basic groups, a borderline symbol may be used with the two symbols separated by a slash. A borderline classification symbol should not be used indiscriminately. Every effort should be made first to place the soil into a single group. Borderline symbols can also be used in laboratory classification, but less frequently.

A borderline symbol may be used when the percentage of fines is visually estimated to be between 45 and 55 percent. One symbol should be for a coarse-grained soil with fines and the other for a fine-grained soil. For example: GM/ML, CL/SC.

A borderline symbol may be used when the percentage of sand and the percentage of gravel is estimated to be about the same, for example, GP/SP, SC/GC, GM/SM. It is practically impossible to have a soil that would have a borderline symbol of GW/SW. However, a borderline symbol may be used when the soil could be either well graded or poorly graded. For example: GW/GP, SW/SP.

A borderline symbol may be used when the soil could be either a silt or a clay. For example: CL/ML, CH/MH, SC/SM.

## FIELD MANUAL

A borderline symbol may be used when a fine-grained soil has properties at the boundary between a soil of low compressibility and a soil of high compressibility. For example: CL/CH, MH/ML.

The order of the borderline symbol should reflect similarity to surrounding or adjacent soils. For example, soils in a borrow area have been predominantly identified as CH. One sample has the borderline symbol of CL and CH. To show similarity to the adjacent CH soils, the borderline symbol should be CH/CL.

The group name for a soil with a borderline symbol should be the group name for the first symbol, except for:

CL/CH - lean to fat clay  
ML/CL - clayey silt  
CL/ML - silty clay

### Preparation for Identification and Visual Classification

A usually dark-brown to black material composed primarily of vegetable tissue in various stages of decomposition with a fibrous to amorphous texture and organic odor is a highly organic soil and classified as peat, PT. Plant forms may or may not be readily recognized. In general, the greater the organic content, the greater the water content, void ratio, and compressibility of peat. Organic soils are often identified by their odor. To check for organic content, the soil can be subjected to the laboratory classification liquid limit test criteria. Organic soils can also be identified through laboratory loss-on-ignition tests. Materials identified as peat are not subjected to the following identification procedures.

## SOIL

Soil identification procedures are based on the minus 3-in (75-mm) particle sizes. All plus 3-in (75-mm) particles must be manually removed from a loose sample, or mentally for an intact sample, before classifying the soil. Estimate and note the percent by volume of the plus 3-in (75-mm) particles, both the percentage of cobbles and the percentage of boulders.

Note: Because the percentages of the particle-size distribution in laboratory classification (ASTM: D 2487) are by dry weight and the estimates of percentages for gravel, sand, and fines are by dry weight, the description should state that the percentages of cobbles and boulders are by volume, not weight, for visual classification. Estimation of the volume of cobbles and boulders is not an easy task. Accurate estimating requires experience. While experienced loggers may be able to successfully estimate the minus 3-in fraction to within 5 percent, the margin of error could be larger for oversize particles. Estimates can be confirmed or calibrated with large scale field gradation tests on critical projects. Given the large possible errors in these estimates, the estimates should not be used as the sole basis for design of processing equipment. Large scale gradations should be obtained as part of the process plant designs.

In most cases, the volume of oversize is estimated in three size ranges, 3 to 5, 5 to 12, and 12 inches and larger. Cobbles are often divided into two size ranges, because in roller compacted fill of 6-in compacted lift thickness, the maximum size cobble is 5 inches. If the purpose of the investigation is not for roller compacted fill, a single size range for cobbles can be estimated.

## FIELD MANUAL

Estimate and note the percentage by dry weight of the gravel, sand, and fines of the fraction of the soil smaller than 3 in (75-mm). The percentages are estimated to the closest 5 percent. The percentages of gravel, sand, and fines must add up to 100 percent, excluding trace amounts. The presence of a component not in sufficient quantity to be considered 5 percent in the minus 3-in (75-mm) portion, is indicated by the term "trace." For example: trace of fines. A trace is not considered in the total of 100 percent for the components.

The first step in the identification procedure is to determine the percentages of fine-grained and coarse-grained materials in the sample. The soil is fine-grained if it contains 50 percent or more fines. The soil is coarse-grained if it contains less than 50 percent fines. Procedures for the description and classification of these two preliminary identification groups follow.

### Procedures and Criteria for Visual Classification of Fine-Grained Soils

Select a representative sample of the material for examination and remove particles larger than the No. 40 sieve (medium sand and larger) until a specimen equivalent to about a handful of representative material is available. Use this specimen for performing the identification tests.

Identification Criteria for Fine-Grained Soils.—The tests for identifying properties of fines are dry strength, dilatency, toughness, and plasticity.

1. *Dry strength*.—Select from the specimen enough material to mold into a ball about 1 in (25 mm) in diameter. Mold or work the material until it has the consistency of putty, adding water if necessary.



## SOIL

From the molded material, make at least three test specimens. Each test specimen should be a ball of material about  $\frac{1}{2}$  in (12 mm) in diameter. Allow the test specimens to dry in air or sun, or dry by artificial means, as long as the temperature does not exceed 60 degrees Centigrade (EC). In most cases, it will be necessary to prepare specimens and allow them to dry over night. If the test specimen contains natural dry lumps, those that are about  $\frac{1}{2}$  in (12 mm) in diameter may be used in place of molded balls. (The process of molding and drying usually produces higher strengths than are found in natural dry lumps of soil). Test the strength of the dry balls or lumps by crushing them between the fingers and note the strength as none, low, medium, high, or very high according to the criteria in table 3-3. If natural dry lumps are used, do not use the results of any of the lumps that are found to contain particles of coarse sand.

Table 3-3.—Criteria for describing dry strength

---

---

None	The dry specimen crumbles with mere pressure of handling.
Low	The dry specimen crumbles with some finger pressure.
Medium	The dry specimen breaks into pieces or crumbles with considerable finger pressure.
High	The dry specimen cannot be broken with finger pressure. Specimen will break into pieces between thumb and a hard surface.
Very High	The dry specimen cannot be broken between thumb and a hard surface.

---

## FIELD MANUAL

The presence of high-strength, water-soluble cementing materials, such as calcium carbonate, may cause exceptionally high dry strengths. The presence of calcium carbonate can usually be detected from the intensity of the reaction with dilute hydrochloric acid (HCl). Criteria for reaction with HCl are presented in a subsequent paragraph.

2. *Dilatancy*.—Select enough material from the specimen to mold into a ball about  $\frac{1}{2}$  in (12 mm) in diameter. Mold the material, adding water if necessary, until it has a soft, but not sticky, consistency. Smooth the soil ball in the palm of one hand with the blade of a knife or spatula. Shake horizontally (the soil ball), striking the side of the hand vigorously against the other hand several times. Note the reaction of the water appearing on the surface of the soil. Squeeze the sample by closing the hand or pinching the soil between the fingers and note reaction as none, slow, or rapid according to the criteria in table 3-4. The reaction criteria are the speeds with which water appears while shaking and disappears while squeezing.

Table 3-4.—Criteria for describing dilatancy

---

---

None	No visible change in the specimen.
Slow	Water slowly appears on the surface of the specimen during shaking and does not disappear or disappears slowly upon squeezing.
Rapid	Water quickly appears on the surface of the specimen during shaking and disappears upon squeezing.

---

## SOIL

3. *Toughness*.—Following completion of the dilatancy test, the specimen is shaped into an elongated pat and rolled by hand on a smooth surface or between the palms into a thread about  $\text{C}$  in (3 mm) diameter. (If the sample is too wet to roll easily, spread the sample out into a thin layer and allow some water loss by evaporation). Fold the sample threads and reroll repeatedly until the thread crumbles at a diameter of about  $\text{C}$  in (3 mm) when the soil is near the plastic limit. Note the time required to reroll the thread to reach the plastic limit. Note the pressure required to roll the thread near the plastic limit. Also, note the strength of the thread. After the thread crumbles, the pieces should be lumped together and kneaded until the lump crumbles. Note the toughness of the material during kneading.

Describe the toughness of the thread and lump as low, medium, or high according to the criteria in table 3-5.

Table 3-5.—Criteria for describing toughness

---

---

Low	Only slight pressure is required to roll the thread near the plastic limit. The thread and the lump are weak and soft.
Medium	Medium pressure is required to roll the thread to near the plastic limit. The thread and the lump have medium stiffness.
High	Considerable pressure is required to roll the thread to near the plastic limit. The thread and the lump have very high stiffness.

---

## FIELD MANUAL

4. *Plasticity*.—On the basis of observations made during the toughness test, describe the plasticity of the material according to the criteria given in table 3-6 (figure 3-5).

**Table 3-6.—Criteria for describing plasticity**

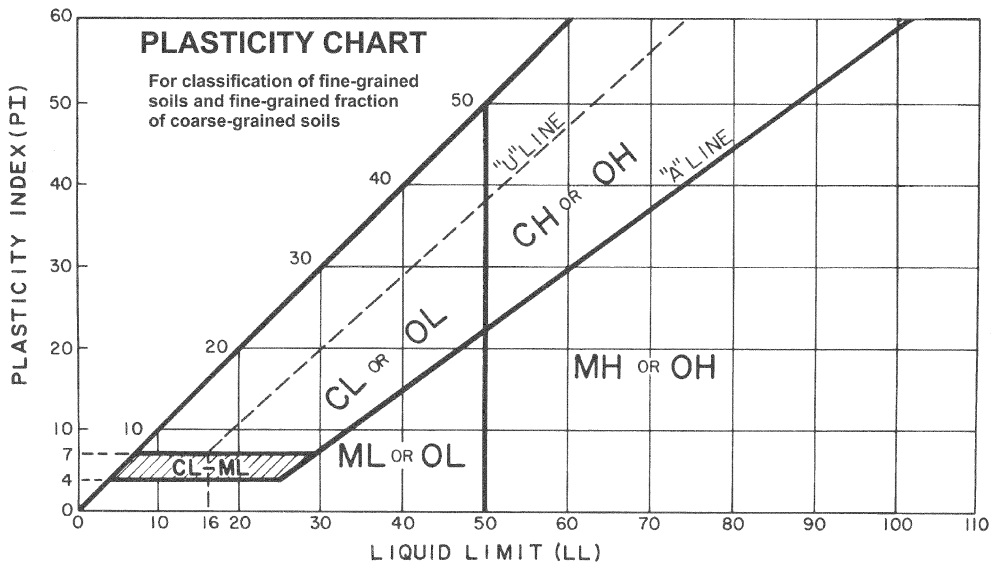
---

---

<b>Nonplastic</b>	A 3-mm thread cannot be rolled at any water content.
<b>Low</b>	The thread can barely be rolled, and the lump cannot be formed when drier than the plastic limit.
<b>Medium</b>	The thread is easy to roll, and not much time is required to reach the plastic limit. The thread cannot be rerolled after reaching the plastic limit. The lump crumbles when drier than the plastic limit.
<b>High</b>	It takes considerable time rolling and kneading to reach the plastic limit. The thread can be rolled several times after reaching the plastic limit. The lump can be formed without crumbling when drier than the plastic limit.

---

After the dry strength, dilatency, toughness, and plasticity tests have been performed, decide on whether the soil is an organic or an inorganic fine-grained soil.



SOIL

Figure 3-5.—Plasticity chart.

## FIELD MANUAL

Identification of Inorganic Fine-Grained Soils.— Classify the soils using the results of the manual tests and the identifying criteria shown in table 3-7. Possible inorganic soils include lean clay (CL), fat clay (CH), silt (ML), and elastic silt (MH). The properties of an elastic silt are similar to those for a lean clay. However, the silt will dry quickly on the hand and have a smooth, silky feel when dry. Some soils which classify as MH according to the field classification criteria are difficult to distinguish from lean clays, CL. It may be necessary to perform laboratory testing to ensure proper classification.

Table 3-7.—Identification of inorganic fine-grained soils from manual tests

Group symbol	Dry strength	Dilatancy	Toughness
ML	None to low	Slow to rapid	Low or thread cannot be formed
CL	Medium to high	None to slow	Medium
MH	Low to medium	None to slow	Low to medium
CH	High to very high	None	High

Some soils undergo irreversible changes upon air drying. These irreversible processes may cause changes in atterberg limits and other index tests. Even unsuspected soils such as low plasticity silts may have differing atterberg limits due to processes like disaggregation. When tested at natural moisture, clay particles cling to silt particles resulting in less plasticity. When dried, the clay disaggregates, making a finer and more well graded mix of particles with increased plasticity.

## SOIL

For foundation studies of existing or new structures, natural moisture atterberg limits are preferred because the in-place material will remain moist. Natural moisture atterberg limits are especially important in critical studies, such as earthquake liquefaction evaluation of silts. On some foundation studies, such as for pumping plant design, consolidation tests will govern, and natural moisture atterbergs are not required. For borrow studies, soils will likely undergo moisture changes, and natural moisture atterberg limits are not required unless unusual mineralogy is encountered.

Identification of Organic Fine-Grained Soils.—If the soil contains enough organic particles to influence the soil properties, classify the soil as an *organic soil*, OL or OH. Organic soils usually are dark brown to black and usually have an organic odor. Often organic soils will change color, (black to brown) when exposed to air. Organic soils normally do not have high toughness or plasticity. The thread for the toughness test is spongy. In some cases, further identification of organic soils as organic silts or organic clays, OL or OH is possible. Correlations between the dilatancy, dry strength, and toughness tests with laboratory tests can be made to classify organic soils in similar materials.

Modifiers for Fine-Grained Soil Classifications.—If based on visual observation, the soil is estimated to have 15 to 25 percent sand and/or gravel, the words "with sand and/or gravel" are added to the group name, for example, LEAN CLAY WITH SAND, (CL); SILT WITH SAND AND GRAVEL (ML). Refer to figures 3-2 and 3-3. If the soil is visually estimated to be 30 percent or more sand and/or gravel, the words "sandy" or "gravelly" are added to the group name. Add the word "sandy" if there appears to be more sand than gravel. Add the word "gravelly" if there appears to be more gravel than sand, for example, SANDY LEAN CLAY (CL); GRAVELLY FAT CLAY (CH);

## **FIELD MANUAL**

**SANDY SILT (ML).** Refer to figures 3-2 and 3-3. Note that the Laboratory Classification follows different criteria.

### **Procedures and Criteria for Visual Classification of Coarse-Grained Soils**

**A representative sample containing less than 50 percent fines is identified as a coarse-grained soil.**

**The soil is a gravel if the percentage by weight of gravel is estimated to be more than the percentage of sand.**

**The soil is a sand if the percentage by weight of sand is estimated to be more than the percentage of gravel.**

**The soil is a clean gravel or clean sand if the percentages of fines are visually estimated to be 5 percent or less. A clean gravel or sand is further classified by grain size distribution.**

**The soil is classified as a WELL GRADED GRAVEL (GW), or as a WELL GRADED SAND (SW), if a wide range of particle sizes and substantial amounts of the intermediate particle sizes are present. The soil is classified as a POORLY GRADED GRAVEL (GP) or as a POORLY GRADED SAND (SP) if the material is predominantly one size (uniformly graded) or the soil has a wide range of sizes with some intermediate sizes obviously missing (gap or skip graded).**

**The soil is identified as either gravel with fines or sand with fines if the percentage of fines is visually estimated to be 15 percent or more.**



## SOIL

Classify the soil as a **CLAYEY GRAVEL (GC)** or a **CLAYEY SAND (SC)** if the fines are clayey as determined by the procedures for fine-grained soil identification.

Identify the soil as a **SILTY GRAVEL (GM)** or a **SILTY SAND (SM)** if the fines are silty as determined by the procedures for fine-grained soil identification.

If the soil is visually estimated to contain 10 percent fines, give the soil a dual classification using two group symbols. The first group symbol should correspond to a clean gravel or sand (GW, GP, SW, SP), and the second symbol should correspond to a gravel or sand with fines (GC, GM, SC, SM). The typical name is the first group symbol plus "with clay" or "with silt" to indicate the plasticity characteristics of the fines. For example, **WELL GRADED GRAVEL WITH CLAY (GW-GC)**; **POORLY GRADED SAND WITH SILT (SP-SM)**. Refer to figure 3-4.

If the specimen is predominantly sand or gravel but contains an estimated 15 percent or more of the other coarse-grained constituent, the words "with gravel" or "with sand" are added to the group name. For example: **POORLY GRADED GRAVEL WITH SAND (GP)**; **CLAYEY SAND WITH GRAVEL (SC)**. Refer to figure 3-4.

If the field sample contained any cobbles and/or boulders, the words "with cobbles" or "with cobbles and boulders" are added to the group name, for example, **SILTY GRAVEL WITH COBBLES (GM)**.

### Abbreviated Soil Classification Symbols

If space is limited, an abbreviated system may be used to indicate the soil classification symbol and name such as in logs, data bases, tables, etc. The abbreviated system

## FIELD MANUAL

is not a substitute for the full name and descriptive information but can be used in supplementary presentations. The abbreviated system consists of the soil classification system based on this chapter, with prefixes and suffixes as listed below.

Prefix: s = sandy                      g = gravelly  
Suffix: s = with sand                g = with gravel  
          c = with cobbles            b = with boulders

The soil classification symbol is enclosed in parentheses. Examples are:

CL, sandy lean clay	s(CL)
SP-SM, poorly graded sand with silt and gravel	(SP-GM)g
GP, poorly graded gravel with sand, cobbles, and boulders	(GP)scb
ML, gravelly silt with sand and cobbles	g(ML)sc

### Description of the Physical Properties of Soil

Descriptive information for classification and reporting soil properties such as angularity, shape, color, moisture conditions, and consistency are presented in the following paragraphs.

#### Angularity

Angularity is a descriptor for coarse-grained materials only. The angularity of the sand (coarse sizes only), gravel, cobbles, and boulders, are described as angular,

## SOIL

subangular, subrounded, or rounded as indicated by the criteria in table 3-8. A range of angularity may be stated, such as: sub-rounded to rounded.

Table 3-8.—Criteria for describing angularity of coarse-grained particles

Angular	Particles have sharp edges and relatively planar sides with unpolished surfaces.
Subangular	Particles are similar to angular description but have rounded edges.
Subrounded	Particles have nearly planar sides but well-rounded corners and edges.
Rounded	Particles have smoothly curved sides and no edges.

### Shape

Describe the shape of the gravel, cobbles, and boulders as “flat, elongated” or “flat and elongated” if they meet the criteria in table 3-9. Indicate the fraction of the particles that have the shape, such as: one-third of gravel particles are flat. If the material is to be processed or used as aggregate for concrete, note any unusually shaped particles.

### Color

Color is an especially important property in identifying organic soils and is often important in identifying other types of soils. Within a given locality, color may also be useful in identifying materials of similar geologic units. Color should be described for moist samples. Note if color

## FIELD MANUAL

Table 3-9.—Criteria for describing particle shape

---

---

The particle shape is described as follows, where length, width, and thickness refer to the greatest, intermediate, and least dimensions of a particle, respectively.

Flat	Particles with width/thickness $>3$ .
Elongated	Particles with length/width $>3$ .
Flat and elongated	Particles meet criteria for both flat and elongated.

---

represents a dry condition. If the sample contains layers or patches of varying colors, this should be noted, and representative colors should be described. The Munsel Color System may be used for consistent color descriptions.

### Odor

Describe the odor if organic or unusual. Soils containing a significant amount of organic material usually have a distinctive odor of decaying vegetation. This is especially apparent in fresh samples, but if the samples are dried, the odor often may be revived by heating a moistened sample. If the odor is unusual, such as that of a petroleum product or other chemical, the material should be described and identified if known. The material may be hazardous, and combustion or exposure should be considered.

### Moisture Conditions

Describe the moisture condition as dry, moist, or wet, as indicated by the criteria in table 3-10.

## SOIL

Table 3-10.—Criteria for describing moisture condition

Dry	Absence of moisture, dusty, dry to the touch.
Moist	Damp but no visible water.
Wet	Visible free water, usually soil is below water table.

### Reaction with HCl

Describe the reaction with HCl as none, weak, or strong, as indicated by the criteria in table 3-11. Calcium carbonate is a common cementing agent. The reaction with dilute hydrochloric acid is important in determining the presence and abundance of calcium carbonate.

Table 3-11.—Criteria for describing reaction with HCl

None	No visible reaction.
Weak	Some reaction, with bubbles forming slowly.
Strong	Violent reaction, with bubbles forming immediately.

### Consistency

Describe consistency (degree of firmness) for intact fine-grained soils as very soft, soft, firm, hard, or very hard, as indicated by the criteria in table 3-12. This observation is inappropriate for soils with significant amounts of gravel. Pocket penetrometer or torvane testing may supplement this data.

## FIELD MANUAL

Table 3-12.—Criteria for describing consistency of in-place or undisturbed fine-grained soils

---

---

Very soft	Thumb will penetrate soil more than 1 in (25 mm).
Soft	Thumb will penetrate soil about 1 in (25 mm).
Firm	Thumb will indent soil about 1/4 in (5 mm).
Hard	Thumb will not indent soil but readily indented with thumbnail.
Very hard	Thumbnail will not indent soil.

---

### Cementation

Describe the cementation of intact soils as weak, moderate, or strong, as indicated by the criteria in table 3-13.

Table 3-13.—Criteria for describing cementation

---

---

Weak	Crumbles or breaks with handling or little finger pressure.
Moderate	Crumbles or breaks with considerable finger pressure.
Strong	Will not crumble or break with finger pressure.

---

### Structure (Fabric)

Describe the structure of the soil according to criteria described in table 3-14. The descriptors presented are for soils only; they are not synonymous with descriptors for rock.

## SOIL

Table 3-14.—Criteria for describing structure

Stratified	Alternating layers of varying material or color; note thicknesses.
Laminated <sup>1</sup>	Alternating layers of varying material or color with layers less than 6 mm thick; note thicknesses.
Fissured <sup>1</sup>	Breaks along definite planes with little resistance to fracturing.
Slickensided <sup>1</sup>	Fracture planes appear polished or glossy, sometimes striated.
Blocky <sup>1</sup>	Cohesive soil that can be broken down into small angular lumps which resist further breakdown.
Lenses	Inclusion of small pockets of different soils, such as small lenses of sand scattered through a mass of clay; note thicknesses.
Homogeneous	Same color and textural or structural appearance throughout.

<sup>1</sup> Do not use for coarse-grained soils with the exception of fine sands which can be laminated.

### Particle Sizes

For gravel and sand-size components, describe the range of particle sizes within each component as defined in the previous terminology paragraph. Descriptive terms, sizes, and examples of particle sizes are shown in table 3-15.

## FIELD MANUAL

Table 3-15.—Particle sizes

Descriptive term	Size	Familiar example within the size range
Boulder	300 mm or more	Larger than a volleyball
Cobble	300 mm to 75 mm	Volleyball - grapefruit - orange
Coarse gravel	75 mm to 20 mm	Orange - grape
Fine gravel	20 mm to No. 4 sieve (5 mm)	Grape - pea
Coarse sand	No. 4 sieve to No. 10 sieve	Sidewalk salt
Medium sand	No. 10 sieve to No. 40 sieve	Openings in window screen
Fine sand	No. 40 sieve to No. 200 sieve	Sugar - table salt, grains barely visible

Describe the maximum particle size found in the sample. For reporting maximum particle size, use the following descriptors and size increments:

Fine sand

Medium sand

Coarse sand

5-mm increments from 5 mm to 75 mm

25-mm increments from 75 mm to 300 mm

100-mm increments over 300 mm

For example: "maximum particle size 35 mm"

"maximum particle size 400 mm"

If the maximum particle size is sand size, describe as fine, medium, or coarse sand; for example, maximum particle size, medium sand.



## SOIL

If the maximum particle size is gravel size, describe the maximum particle size as the smallest sieve opening that the particle would pass.

If the maximum particle size is cobble or boulder size, describe the maximum dimension of the largest particle.

### Particle Hardness

Describe the hardness of coarse sand and larger particles as hard, or state what happens when the particles are hit by a hammer; e.g., gravel-size particles fracture with considerable hammer blow, some gravel-size particles crumble with hammer blow. Hard means particles do not fracture or crumble when struck with a hammer. Remember that the larger the particle, the harder the blow required to fracture it. A good practice is to describe the particle size and the method that was used to determine the hardness.

### Additional Descriptive Information

Additional descriptive information may include unusual conditions, geological interpretation or other classification methods, such as:

Presence of roots or root holes or other organic material or debris;

Degree of difficulty in drilling or augering hole or excavating a pit; or

Raveling or caving of the trench, hole, pit, or exposure;

*or*

Presence of mica or other predominant minerals.

A local or commercial name and/or a geologic interpretation should be provided for the soil.

## FIELD MANUAL

A classification or identification of the soil according to other classification systems may be added.

### Narrative Descriptions and Examples

The description should include the information shown in tables 3-16 and 3-17, a checklist for the description of soils. Example descriptions follow.

Table 3-16.—Checklist for the description of soil classification and identification

- 
- 
- |     |   |
|-----|---|
| 1.  | Group name and symbol   |
| 2.  | Percent gravel, sand, and/or fines                                    |
| 3.  | Percent by volume of cobbles and boulders                             |
| 4.  | Particle size<br>Gravel - fine, coarse<br>Sand - fine, medium, coarse |
| 5.  | Particle angularity<br>angular subangular subrounded rounded          |
| 6.  | Particle shape<br>flat elongated flat and elongated                   |
| 7.  | Maximum particle size or dimension                                    |
| 8.  | Hardness of coarse sand and larger particles                          |
| 9.  | Plasticity of fines<br>nonplastic low medium high                     |
| 10. | Dry strength<br>none low medium high very high                        |
| 11. | Dilatancy<br>none slow rapid  |
| 12. | Toughness<br>low medium high  |
| 13. | Color (when moist)  |
| 14. | Odor (if organic or unusual)  |
| 15. | Moisture<br>dry moist wet   |
| 16. | Reaction with HCL<br>none weak strong                                 |
-

## SOIL

Table 3-17.—Checklist for the description  
of in-place conditions

---

---

In-place conditions:

1. Consistency (fine-grained soils only)  
very soft soft firm hard very hard
  2. Cementation  
weak moderate strong
  3. Structure  
stratified laminated fissured slickened lensed  
homogeneous
  4. Geologic interpretation and/or local name, if any
  5. Additional comments and description  
Presence of roots or root holes  
Presence of mica, gypsum, etc.  
Surface coatings  
Caving or sloughing of excavation  
Excavation difficulty
- 

**Example 1: CLAYEY GRAVEL WITH SAND AND COBBLES (GC)**—Approximately 50 percent fine to coarse, sub-rounded to subangular gravel; approximately 30 percent fine to coarse, subrounded sand; approximately 20 per-cent fines with medium plasticity, high dry strength, no dilatancy, medium toughness; weak reaction with HCl; original field sample had about 5 percent (by volume) subrounded cobbles, maximum size 150 mm.

**IN-PLACE CONDITIONS:** firm, homogeneous, dry, brown.

**GEOLOGIC INTERPRETATION:** alluvial fan.

Abbreviated symbol is (GC)sc.

**Example 2: WELL GRADED GRAVEL WITH SAND (GW)**—Approximately 75 percent fine to coarse, hard, sub-angular gravel; approximately 25 percent fine to

## FIELD MANUAL

coarse, hard, subangular sand; trace of fines; maximum size 75 mm, brown, dry; no reaction with HCl.

Abbreviated symbol is (GW)s

**Example 3: SILTY SAND WITH GRAVEL (SM)**—Approximately 60 percent predominantly fine sand; approximately 25 percent silty fines with low plasticity, low dry strength, rapid dilatancy, and low toughness; approximately 15 percent fine, hard, subrounded gravel, a few gravel-size particles fractured with hammer blow; maximum size 25 mm; no reaction with HCl.

**IN-PLACE CONDITIONS:** firm, stratified, and contains lenses of silt 1- to 2-in thick, moist, brown to gray; in-place density was 106 pounds per cubic foot (lb/ft<sup>3</sup>), and in-place moisture was 9 percent.

**GEOLOGIC INTERPRETATION: ALLUVIUM**

Abbreviated symbol is (SM)g.

**Example 4: ORGANIC SOIL (OL/OH)**—Approximately 100 percent fines with low plasticity, slow dilatancy, low dry strength, and low toughness; wet, dark brown, organic odor, weak reaction with HCl.

Abbreviated symbol is (OL/OH).

**Example 5: SILTY SAND WITH ORGANIC FINES (SM)**—Approximately 75 percent fine to coarse, hard, subangular reddish sand, approximately 25 percent organic and silty dark-brown nonplastic fines with no dry strength and slow dilatancy; wet; maximum size, coarse sand; weak reaction with HCl.

Abbreviated symbol is (SM)

## SOIL

**Example 6: POORLY GRADED GRAVEL WITH SILT, SAND, COBBLES, AND BOULDERS (GP-GM)**—Approximately 75 percent fine to coarse, hard, subrounded to subangular gravel; approximately 15 percent fine, hard, subrounded to subangular sand; approximately 10 percent silty nonplastic fines; moist, brown; no reaction with HCl; original field sample had approximately 5 percent (by volume) hard, subrounded cobbles and a trace of hard, subrounded boulders with a maximum dimension of 500 mm.

Abbreviated symbol is (GP-GM)scb.

### Use of Soil Classification as Secondary Identification Method for Materials Other Than Natural Soils

#### General

Materials other than natural soils may be classified and their properties identified and described using the same procedures presented in the preceding subsections. The following materials are not considered soils and should not be given a primary USCS soil classification:

#### Partially lithified or poorly cemented materials

Shale	Claystone
Sandstone	Siltstone
Decomposed granite	

#### Processed, manmade, or other materials

Crushed rock	Slag
Crushed sandstone	Shells
Cinders	Ashes

## FIELD MANUAL

Identification criteria may be used for describing these materials, especially for describing particle sizes and shapes and identifying those materials which convert to soils after field or laboratory processing. Description format and classification for these materials are discussed individually in the following paragraphs.

### Partially Lithified or Cemented Materials

Partially lithified or poorly cemented materials may need to be classified because the material will be excavated, processed, or manipulated for use as a construction material. When the physical properties are to be determined for these materials for classification, the material must be processed into a soil by grinding or slaking in water (shale, siltstone, poorly indurated ash deposits).

The physical properties and resulting classification describe the soil type as created by reworking the original material. Soil classifications can then be used as a secondary identification. However, the classification symbol and group name must be reported in quotation marks in any logs, tables, figures, and reports. If laboratory tests are performed on these materials, the results must be reported as shown in figure 3-6.

An example of a written narrative for either a test pit or auger hole log based on visual classification is as follows:

<u>Symbol</u>	<u>Description</u>
Shale Fragments	3.4- to 7.8-foot (ft) Shale Fragments— Retrieved as 2- to 4-in pieces of shale from power auger hole, dry, brown, no reaction with HCl. After slaking in water for 24 hours, material classified as "SANDY CLAY (CH)"—

SUMMARY OF PHYSICAL PROPERTIES TEST RESULTS (Include Details)

SI METRIC  
PROJECT

FEATURE

TABLE 3.3.36  
SHEET 1 of 1

SAMPLE NUMBER	IDENTIFICATION		PARTICLE SIZE FRACTIONS IN PERCENT							CONSISTENCY LIMITS			SPECIFIC GRAVITY			WATER CONTENT			
	HOLE NUMBER	DEPTH, m	LOCATION (SEE DRAWING)	FINE				COARSE SAND, 4.75 mm TO 75 µm	COARSE SILT, 4.75 mm TO 75 µm	COARSE SAND, 4.75 mm TO 75 µm	LIQUID LIMIT, %	PLASTICITY INDEX, %	SHRINKAGE LIMIT, %	WATER NO. X	PLUS NO. 4		OPTIMUM WATER CONTENT, %	NATURAL WATER CONTENT, %	DEGREE OF SATURATION, %
				PERCENT FINER THAN 60 µm	PERCENT FINER THAN 75 µm	PERCENT FINER THAN 150 µm	PERCENT FINER THAN 300 µm								PERCENT FINER THAN 4.75 mm	PERCENT FINER THAN 20 µm			
Example 1																			
12	AP-13	4.7-6.2	shale fragments (as received)																
			* "CL"	53	30	17													
Example 2																			
13	DW 212-B	27.2-28.7	siltstone (as received)														118	38	17
			* "ML"	90	41	9				27	3								
Example 3																			
14	Commercial Source		Crushed Sandstone (as received)																
			* "SP-SM"	5	4	91				23	2								
Example 4																			
15	DH No. 3		Crushed Flank																
			* "GP"	0	0	11	89												
Example 5																			
16	Waste Pile	78	Slag																
	CP and 1		* "GP"	2	1	25	72												
			* properties of material after processing in laboratory																

Figure 3-6.—Sample of test results summary.

SOIL

## FIELD MANUAL

Approximately 60 percent fines with high plasticity, high dry strength, no dilatancy and high toughness; approximately 35 percent fine to medium, hard sand; approximately 5 percent gravel-size pieces of shale.

### Processed or Manmade Materials

Processed, manmade, or other materials are also used as construction materials, and classification can be used as a secondary identification. However, for these processed materials, the group name and classification symbol are to be within quotation marks. If laboratory tests are performed on these materials, the results must be reported as shown in table 3-6.

An example of a written narrative for logs for visual classification is as follows:

<u>Symbol</u>	<u>Description</u>
CRUSHED ROCK	Stockpile No. 3 CRUSHED ROCK— processed gravel and cobbles from P.T. NO. 7; "POORLY GRADED GRAVEL (GP)"—approximately 90 percent fine, hard, angular, gravel-size particles; approximately 10 percent coarse, angular, sand-size particles; dry, tan, no reaction with HCl.

### Special Cases for Classification

Some materials that require a classification and description according to USBR 5000 [1] or USBR 5005 [2] should not have a heading that is a classification group name.



## SOIL

When these materials will be used in, or influence, design and construction, they should be described according to the criteria for logs of test pits and auger holes and the classification symbol and typical name placed in quotation marks similar to the previous discussion on secondary identification method for materials other than natural soils. The heading should be as follows:

Topsoil

Landfill

Road surfacing Uncompacted or Compacted

Fill

For example:

Classification

<u>Symbol</u>	<u>Description</u>
TOPSOIL	0.0-0.8 meter (m) TOPSOIL—would be classified as "ORGANIC SILT (OL)." Approximately 80 percent fines with low plasticity, slow dilatancy, low dry strength, and low toughness; approximately 20 percent fine to medium sand; wet, dark brown, organic odor, weak reaction with HCl; roots present throughout.

Some material should be described but not given a classification symbol or group name, such as landfill (trash, garbage, etc.) or asphalt road. All of the above listed terms are only examples; this is not a complete list. If the above materials are not to be used and will not influence design or construction, only the basic term listed above need be shown on the logs without a complete description or classification.

**FIELD MANUAL**  
**BIBLIOGRAPHY**

- [1] Bureau of Reclamation, U.S. Department of the Interior, USBR-5000, "Procedure for Determining Unified Soil Classification (Laboratory Method)," *Earth Manual*, Part II, 3rd edition, 1990.
- [2] Bureau of Reclamation, U.S. Department of the Interior, USBR-5005, "Procedure for Determining Unified Soil Classification (Visual Method)," *Earth Manual*, Part II, 3rd edition, 1990.
- [3] American Society for Testing and Materials, ASTM D-2487, "Standard Classification of Soils for Engineering Purposes," *ASTM Annual Book of Standards*, Volume 04.08 on Soil and Rock, Section 4 - Construction, West Conshohocken, PA, 1996.
- [4] American Society for Testing and Materials, ASTM D-2488, "Standard Practice for Description and Identification of soils (Visual-Manual Procedure)," *ASTM Annual Book of Standards*, Volume 04.08 on Soil and Rock, Section 4 - Construction, West Conshohocken, PA, 1996.
- [5] U.S. Department of Agriculture, *Agriculture Handbook No. 436*, Appendix I (Soil Taxonomy), December 1975.
- [6] Bureau of Reclamation, U.S. Department of the Interior, USBR 3900, "Standard Definitions of Terms and Symbols Relating to Soil Mechanics," *Earth Manual*, Part II, 3rd edition, 1990.

## **Chapter 4**

# **CLASSIFICATION OF ROCKS AND DESCRIPTION OF PHYSICAL PROPERTIES OF ROCK**

### **Introduction**

Uniformity of definitions, descriptors, and identification of rock units is important to maintain continuity in geologic logs, drawings, and reports from a project with multiple drilling sessions, different loggers and mappers. Also important is the recording of all significant observable parameters when logging or mapping. This chapter presents a system for the identification and classification of rocks and includes standard terminology and descriptive criteria for physical properties of engineering significance. The standards presented in this chapter may be expanded or modified to fit project requirements.

### **Rock Classification**

Numerous systems are in use for field and petrographic classification of rocks. Many classifications require detailed petrographic laboratory tests and thin sections, while others require limited petrographic examination and field tests. The Bureau of Reclamation (Reclamation) has adopted a classification system which is modified from R.B. Travis [1]. While not based entirely on field tests or field identification of minerals, many of the classification categories are sufficiently broad that field identification is possible. Even where differences in the mineral constituents cannot be determined precisely in the field, differences usually are not significant enough to affect the engineering properties of the rock if classified somewhat incorrectly by lithologic name. Detailed mineralogical identification and petrographic classification can be performed on hand samples or core samples submitted to a petrographic laboratory.

## FIELD MANUAL

If samples are submitted to a petrographic laboratory, the petrographic classification generally will coincide with the classification according to Travis. The petrographic igneous rock classifications are somewhat more precise and include specialty rock types based upon mineral composition, texture, and occurrence. For example, a lamprophyric dike composed of green hornblende phenocrysts or clinopyroxene in the groundmass could be classified as spessartite, whereas a lamprophyre containing biotite with or without clinopyroxene could be classified as a kersantite. Sedimentary rock classifications generally include grain size, type of cement or matrix, mineral composition in order of increasing amounts greater than 15 percent, and the rock type, such as medium-grained, calcite-cemented, feldspathic-quartzose sandstone, and coarse- to fine-grained, lithic-feldspathic-quartzose gray-wacke with an argillaceous-ferruginous-calcareous matrix. Metamorphic rock classifications include specific rock types based upon crystal size, diagnostic accessory minerals, mineralogical composition in increasing amounts greater than 15 percent, and structure. Two examples of metamorphic rock descriptions are medium-grained, hornblende-biotite schist, or fine- to medium-grained, garnetiferous, muscovite-chlorite-feldspar-quartz gneiss. The above classification can be abbreviated by the deletion of mineral names from the left to right as desired. The mineral type immediately preceding the rock name is the most diagnostic.

The term "quartzite" is restricted to a metamorphic rock only. The sedimentary sandstone equivalent is termed a "quartz cemented quartzose sandstone."

Samples submitted to a petrographic laboratory should be representative of the in-place rock unit. For example, if a granitic gneiss is sampled but only the granite portion submitted, the rock will be petrographically classified as

## ROCKS

a granite since the gneissic portion cannot be observed or substantiated by the thin section and hand specimen. Petrographic classifications can be related to the engineering properties of rock units and are important.

Geologic rock unit names should be simple, and general rock names should be based on either field identification, existing literature, or detailed petrographic examination, as well as engineering properties. Overclassification is distracting and unnecessary. For example, use "hornblende schist" or "amphibolite" instead of "sericite-chlorite-calcite-hornblende schist." The term "granite" may be used as the rock name and conveys more to the designer than the petrographically correct term "nepheline-syenite porphyry." Detailed mineralogical descriptions may be provided in reports when describing the various rock units and may be required to correlate between observations, but mineralogical classifications are not desirable as a rock unit name unless the mineral constituents or fabric are significant to engineering properties.

The classification for igneous, sedimentary, metamorphic, and pyroclastic rocks is shown on figures 4-1, 4-2, 4-3, and 4-4, respectively. These figures are condensed and modified slightly from Travis' classifications, but the more detailed original classifications of Travis are acceptable. Figure 4-5 or appropriate American Geological Institute (AGI) data sheets are suggested for use when estimating composition percentages in classification.

### **Description of Rock**

Adequate descriptors, a uniform format, and standard terminology must be used for all geologic investigations to properly describe rock foundation conditions. These

COLOR	LIGHT								DARK				SPECIAL TYPES
	QUARTZ		> 10 %		< 10 %		PLAGIOCLASE				CHIEFLY PYROXENE AND/OR OLIVINE		
	FELDSPAR		POTASSIUM FELDSPAR > 2/3 TOTAL FELDSPAR		POTASSIUM FELDSPAR 1/3-2/3 TOTAL FELDSPAR		> 10 %		< 10 %				
CHIEF ACCESSORY MINERALS		HORNBLende BIOTITE MUSCOVITE		HORNBLende BIOTITE PYROXENE		HORNBLende, BIOTITE, PYROXENE		PYROXENE OLIVINE		SERPENTINE IRON ORE			
FINE TO COARSE GRAIN	EGG GRANULAR Batholiths, Topoliths, stocks large laccoliths, thick dikes and sills.		GRANITE	SYENITE	QUARTZ MONZONITE	MONZONITE	GRANDIORITE	QUARTZ DIORITE	DIORITE		GABBRO	PERIDOTITE	<ul style="list-style-type: none"> <li>PEGMATITE - Very coarse grained, normally silicic, rock (or small irregular mass).</li> <li>APLITE - Fine-grained rock having sugary texture.</li> </ul>
	FINE TO COARSE GRAIN GROUND MASS Laccoliths, dikes, sills, plugs, small stocks, margins, of larger masses		GRANITE PORPHYRY	SYENITE PORPHYRY	QUARTZ MONZONITE PORPHYRY	MONZONITE PORPHYRY	GRANDIORITE PORPHYRY	QUARTZ DIORITE PORPHYRY	DIORITE PORPHYRY	GABBRO PORPHYRY	PERIDOTITE PORPHYRY	LAMPORPHYRE - Dark rock with high percentage FeMg materials as phenocrysts and in ground mass.	
PORPHYRITIC	APHANITIC GROUND MASS Dikes, sills, laccoliths, surface flows, margins of larger masses, welded tufts.		RHYOLITE PORPHYRY	TRACHYTE PORPHYRY	QUARTZ LATITE PORPHYRY	LATITE PORPHYRY	DACITE PORPHYRY		ANDESITE PORPHYRY	BASALT PORPHYRY	RARE	<ul style="list-style-type: none"> <li>TRAP - dark-colored aphanitic rock,</li> <li>FELSITE - light-colored aphanitic rock.</li> </ul>	
	MICROCRYSTALLINE Dikes, sills, surface flows, margins of larger masses, welded tufts.		RHYOLITE	TRACHYTE	QUARTZ LATITE	LATITE	DACITE		ANDESITE	BASALT			
APHANITIC	GLASSY Surface flows, margins of dikes and sills, welded tufts.		OBSIDIAN - dark colored PITCHSTONE - resinous VITROPHYRE - porphyritic		Normally it is not possible to determine the composition of these rocks. They are customarily designated by the names at the left. Basic glass is rare so rocks named, except scoria, will normally be silicic. If the approximate composition (by close association) can be determined, the name may be prefixed by the name of the appropriate aphanitic rock, for example, "trachyte obsidian" or "latite vitrophyre". In general, scoria is basic; basic obsidian is called "tachylite"; and spherulite tachylite is "variolite".							<ul style="list-style-type: none"> <li>* These are somewhat vague terms and generally should not be used.</li> </ul>	
U. M.	PERLITE - concentric fractures PUMICE - light colored, finely vesicular SCORIA - dark colored, coarsely vesicular												

\* The names in these rows should be used if there are >50% phenocrysts. If there are < 50% phenocrysts, the adjective "porphyritic" should be used, for example, "porphyritic granite".

Figure 4-1.—Field classification of igneous rocks (modified after R.B. Travis [1955]).

TEXTURE	GRAIN SIZE <0.0625 mm			GRAIN SIZE 0.0625 - 2 mm					GRAIN SIZE >2 mm			
	CRYSTALLINE, CLASTIC, AMORPHOUS, BIOCLASTIC, ETC.			CLASTIC					CLASTIC			
COMPOSITION OF MAJOR FRACTION	CLAY MINERALS or Clay-size Materials	Composition as indicated in left column	CHIEFLY CALCITE OR DOLOMITE	CHIEFLY QUARTZ	QUARTZ with 10-25% FELDSPAR	QUARTZ with >10% ROCK FRAGMENTS	QUARTZ with > 25% FELDSPAR	QUARTZ FELDSPAR ROCK FRAGMENTS	PYROCLASTICS	CHIEFLY ONE CONSTITUENT Homogeneous breccias and conglomerates	SEVERAL CONSTITUENTS Mixed breccias and conglomerates	
COMPOSITION OF MINOR FRACTION	<10 % MINOR FRACTION		LIMESTONE, DOLOMITE, ETC.	QUARTZOSE SANDSTONE	FELDSPATHIC SANDSTONE	LITHIC SANDSTONE	ARKOSE	GRAYWACKE	Refer to Figure 11-4-4 for classification of Pyroclastics	Name consists of chief constituent and size, as QUARTZ COBBLE CONGLOMERATE, LIMESTONE PEBBLE BRECCIA, ETC.	Name consists of "mixed" size, as MIXED BOULDER BRECCIA. Name may include composition as ANDESITE-CHERT-ARKOSE CONGLOMERATE	
	CLAY MINERALS or Clay-size materials	CLAYSTONE, SILTSTONE - nonfissile SHALE - fissile ARGILLITE - highly indurated BENTONITE - sodium montmorillonite	ARGILLACEOUS LIMESTONE, MARL, ETC.	ARGILLACEOUS QUARTZOSE SANDSTONE	ARGILLACEOUS FELDSPATHIC SANDSTONE	ARGILLACEOUS LITHIC SANDSTONE	ARGILLACEOUS ARKOSE	ARGILLACEOUS GRAYWACKE		ARGILLACEOUS (SIZE) CONGLOMERATE	ARGILLACEOUS MIXED CONGLOMERATE, GLACIAL TILL, FANGLOMERATE	
	SILICA OPAL CHALCEDONY QUARTZ, CHERT	SILICEOUS SHALE, SILICEOUS CLAYSTONE, ETC.	DIATOMITE, RADIOLARITE, SILICEOUS OOLITE, OOLITE CHERT,	SILICEOUS LIMESTONE, CHERTY LIMESTONE, ETC.	SILICEOUS QUARTZOSE SANDSTONE	SILICEOUS FELDSPATHIC SANDSTONE	SILICEOUS LITHIC SANDSTONE	SILICEOUS ARKOSE		SILICEOUS GRAYWACKE	SILICEOUS (SIZE) CONGLOMERATE	SILICEOUS MIXED (SIZE) CONGLOMERATE
	CALCITE OR DOLOMITE	CALCAREOUS SHALE, ETC.	LIMESTONE DOLOMITE CLASTIC LIMESTONE CALICHE - lime-rich deposit formed near surface OOLITE LIMESTONE FOSSILIFEROUS LIMESTONE CHALK		CALCAREOUS QUARTZOSE SANDSTONE	CALCAREOUS FELDSPATHIC SANDSTONE	CALCAREOUS LITHIC SANDSTONE	CALCAREOUS ARKOSE		CALCAREOUS GRAYWACKE	CALCAREOUS (SIZE) CONGLOMERATE	CALCAREOUS MIXED (SIZE) CONGLOMERATE

Rocks including significant quantities of iron, carbon, or miscellaneous salts follow the above format. For example: ferruginous quartzose sandstone, coal, carbonaceous shale, gypsum, phosphatic limestone.

**Figure 4-2.—Field classification of sedimentary rocks (modified after R.B. Travis [1955]).**

ROCKS

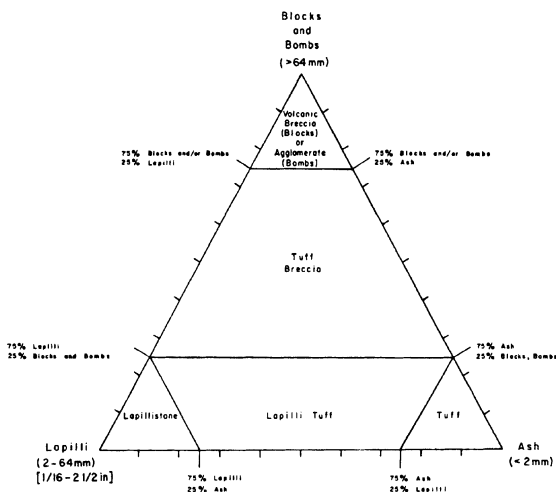
COLOR	CHIEF MINERALS	ACCESSORY MINERALS	NON-DIRECTIONAL STRUCTURE (MASSEVE OR GRANULOS)		DIRECTIONAL STRUCTURE (LINEATED OR FOLIATED)				PLUTONIC METAMORPHISM	
			CONTACT METAMORPHISM		NEOQUINAL METAMORPHISM	REGIONAL METAMORPHISM				MIGMATITIC
			FINE	FINE TO COARSE	CATACLASTIC	HIGHLY FOLIATED	LESS FOLIATED			
						SLATY APHANITIC	PHYLITIC FINE	SCHISTOSE FINE TO COARSE		
↑ LIGHTER	FELDSPAR	ACTINOLITE ALBITE ANDALUSITE ANTHOPHYLLITE BIOTITE OMPHACITE CHELITE CHLORITOID CORDIERITE DIOPSIDE DUSTALITE EPIDOTE GARNET GLAUCOPHANE GRAPHITE KYANITE MUSCOVITE OLIVINE PYROPHYLLITE PHELOSITE SAPPHIRE SERICITE SERPENTINE SILLIMANITE STAUROLITE TREMOLITE WOLLASTONITE	HORNFELS	METAQUARTZITE	These rocks are formed by crushing with only minor recrystallization	SLATE	PHYLITE	GNEISS	These rocks have a gneissose, streaked, or irregular structure produced by intimate mixing of metamorphic and magmatic materials. When they can be recognized as "mixed rock", they are called migmatite gneiss. They may originate by injection (injection migmatite, injection gneiss, or littenitic gneiss), or by differential fusion. Many so-called migmatites probably originate by partial granitization or by metamorphic differentiation. But at great depth these processes apparently do not differ substantially from the igneous processes forming migmatite, so the products are usually indistinguishable. Migmatites are named by prefixing the rock name of the granitic material to the appropriate root as "granite migmatite", "nonzonal injection migmatite", etc.	
↑ DARKER	QUARTZ			AMPHIBOLITE	CATACLASTIC MYLONITE Foliated, aphanitic					SLATE
↑ DARKER	MICA		SOAPSTONE	FLASER GRANITE, FLASER DIORITE, FLASER CONGLOMERATE ETC. - Flaser structure, lenses and layers of original or relatively unaltered granular minerals surrounded by matrix of highly sheared and crushed material.	SLATE	PHYLITE	SCHIST (AMPHIBOLITE)	AUGEN GNEISS - Augen structure		
↑ DARKER	HORNBLende									AMPHIBOLITE
↑ DARKER	CHLORITE		MARBLE	FLASER GRANITE, FLASER DIORITE, FLASER CONGLOMERATE ETC. - Flaser structure, lenses and layers of original or relatively unaltered granular minerals surrounded by matrix of highly sheared and crushed material.	SLATE	PHYLITE	SCHIST (AMPHIBOLITE)	AUGEN GNEISS - Augen structure		
↑ DARKER	ACTINOLITE									AMPHIBOLITE
↑ DARKER	TREMOLITE		SKARN	FLASER GRANITE, FLASER DIORITE, FLASER CONGLOMERATE ETC. - Flaser structure, lenses and layers of original or relatively unaltered granular minerals surrounded by matrix of highly sheared and crushed material.	SLATE	PHYLITE	SCHIST (AMPHIBOLITE)	AUGEN GNEISS - Augen structure		
↑ DARKER	TALC									AMPHIBOLITE
↑ DARKER	CALCITE AND/OR EDOULMITE		SERPENTINITE	FLASER GRANITE, FLASER DIORITE, FLASER CONGLOMERATE ETC. - Flaser structure, lenses and layers of original or relatively unaltered granular minerals surrounded by matrix of highly sheared and crushed material.	SLATE	PHYLITE	SCHIST (AMPHIBOLITE)	AUGEN GNEISS - Augen structure		
↑ DARKER	CALC-SILICATES									AMPHIBOLITE
↑ DARKER	SERPENTINITE		SERPENTINITE	FLASER GRANITE, FLASER DIORITE, FLASER CONGLOMERATE ETC. - Flaser structure, lenses and layers of original or relatively unaltered granular minerals surrounded by matrix of highly sheared and crushed material.	SLATE	PHYLITE	SCHIST (AMPHIBOLITE)	AUGEN GNEISS		

Naming a metamorphic rock consists chiefly of prefixing the structural term with mineral names or an appropriate rock name. The rock name indicates either the original rock, if recognizable, or the new mineral composition. The prefix "meta", as "Metagebro", "metasandstone", "metasilt", etc., is applied to rocks that have undergone considerable recrystallization but have largely retained their original fabric. Most of the minerals listed as accessories are genetically important and if present should be included in the rock name regardless of their quantity.

Figure 4-3.—Field classification of metamorphic rocks (modified after R.B. Travis [1955]).

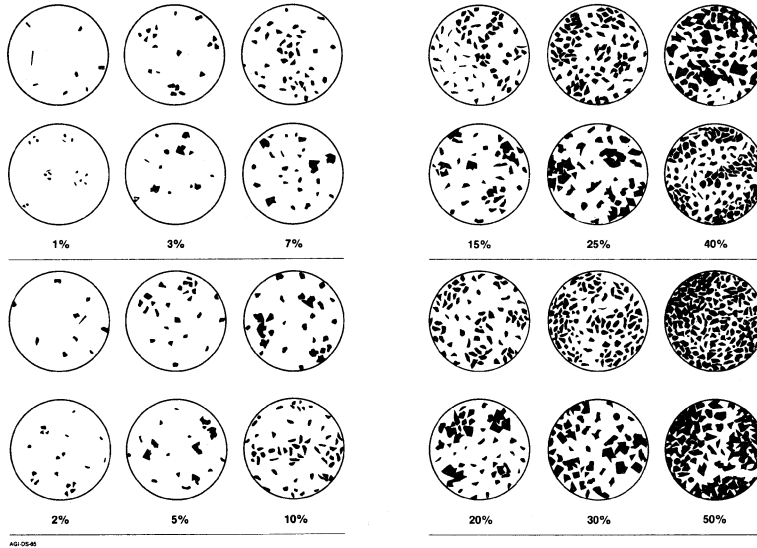


## ROCKS



**Figure 4-4.—Field classification of pyroclastic rocks. Blocks are angular to subangular clasts > 64 millimeters (mm); bombs are rounded to subrounded clasts > 64 mm. Determine percent of each size present (ash, lapilli, blocks, and bombs) and list in decreasing order after rock name. Precede rock name with the term "welded" for pyroclastic rocks which retained enough heat to fuse after deposition. Rock names for such deposits are usually selected from the lower right portion of the classification diagram above. (Modified from Fisher, 1966 [2] and Williams and McBirney, 1979 [3]).**

paragraphs provide descriptors for those physical characteristics of rock that are used in logs of exploration, in narratives of reports, and on preconstruction geologic maps and cross sections, as well as construction or "as-built" drawings. The alphanumeric descriptors provided may be used in data-field entries of computer generated



**Figure 4-5.—Charts for estimating percentage of composition of rocks and sediments.[4]**

## ROCKS

logs. Chapter 5 establishes descriptors for the physical characteristics of discontinuities in rock required for engineering geologic studies.

All descriptors should be defined and included in a legend when submitting data for design and/or records of construction. An example of a legend and explanation is figure 4-6, Reclamation standard drawing 40-D-6493, may be used for geologic reports and specifications where the standard descriptors and terminology established for rock are used during data collection.

### **Format for Descriptions of Rock**

Engineering geology rock descriptions should include generalized lithologic and physical characteristics using qualitative and quantitative descriptors. A general format for describing rock in exploration logs and legends on general note drawings is:

- Rock unit (member or formation) name
- Lithology with lithologic descriptors
  - composition (mineralogy)
  - grain/particle size
  - texture
  - color
- Bedding/foliation/flow texture
- Weathering
- Hardness/strength
- Contacts
- Discontinuities (includes fracture indexes)
- Permeability data (as available from testing)
- Moisture conditions

Example descriptions are presented in a later section.

## FIELD MANUAL

### **Rock Unit Names and Identification**

Rock unit names not only are required for identification purposes but may also provide indicators of depositional environment and geologic history, geotechnical characteristics, and correlations with other areas. A simple descriptive name and map symbol should be assigned to provide other users with possible engineering characteristics of the rock type. The rock unit names may be stratigraphic, lithologic, genetic, or a combination of these, such as Navajo Sandstone (Jn), Tertiary shale (Tsh), Jurassic chlorite schist (Jcs), Precambrian granite (Pcgr), or metasediments (ms). Bedrock units of similar physical properties should be delineated and identified as to their engineering significance as early as possible during each geologic study. Planning study maps and other large-scale drawings may require geologic formations or groups of engineering geologic units with descriptions of their engineering significance in accompanying discussions.

Units should be differentiated by engineering properties and not necessarily formal stratigraphic units where differences are significant. Although stratigraphic names are not required, units should be correlated to stratigraphic names in the data report or by an illustration, such as a stratigraphic column. Stratigraphic names and ages (formation, member) may be used as the rock unit name.

For engineering studies, each particular stratigraphic unit may require further subdivisions to identify engineering parameters. Examples of important engineering properties are:

- Susceptibility to weathering or presence of alteration

# ROCKS

## WEATHERING

**FRESH (F0):** Body of rock is not oxidized or discolored; fracture surfaces are not oxidized or discolored\*\* or separation of grain boundaries; no change of texture and no noticeable hammer rings when crystalline rock is struck.

**SLIGHTLY WEATHERED TO FRESH (F1-F2)\*\***

**SLIGHTLY WEATHERED (F1):** Discoloration or oxidation is limited to surface of rock or sharp edges. Fracture surfaces are not oxidized or discolored. Fracture surfaces have minor to moderate discoloration or oxidation; no visible separation of grain boundaries. Fracture surfaces are free of soluble minerals that may be present. Hammer rings when crystalline rocks are struck. Body of rock is not weakened by weathering.

**MODERATELY TO SLIGHTLY WEATHERED (F3-F4)\*\***

**MODERATELY WEATHERED (F3):** Discoloration or oxidation extends from fractures, usually throughout body of rock. Ferromagnesian minerals are "rusty," ferrous crystals are "cloudy." All fracture surfaces are discolored or oxidized, partial opening of grain boundaries visible; fracture surfaces generally prepared and soluble minerals have been washed. Hammer rings when rock is struck; body of rock is slightly weakened.

**INTERMEDIATE TO MODERATELY WEATHERED (F5-F6)\*\***

**INTERMEDIATELY WEATHERED (F5):** Body of rock is discolored or oxidized throughout; all cleavage and parting surfaces are altered to clay or some other mineral. Fracture surfaces are discolored or oxidized. Some fine scale partial separation of grain boundaries, rock is friable; in situ disintegration of granitic masses in contact with fracture surfaces and leaching of soluble minerals may be complete. Rock has dull coarse chert-like hammer rock is weakened, usually can be broken with moderate to heavy manual pressure or by light hammer blow without fracture to planes of weakness.

**VERY INTERMEDIATELY WEATHERED (F6)\*\***

**VERY DISCOLORED (F6):** Body of rock is discolored or oxidized throughout; but resistant effects such as weathering or alteration of feldspars and ferromagnesian minerals are complete. Cleavage and parting surfaces are complete separation of grain boundaries (disaggregated), partial or complete removal rock structure may be preserved, but resembles a soil.

**NOTE:** Weathering categories are established primarily for crystalline rocks and those of ferromagnesian minerals. Weathering categories for sedimentary rocks will not always fit the categories established. Weathering categories may be modified for particular site conditions or alteration such as hydrothermal alteration. Where modified criteria are established, they are identified and described.

\* Characteristics of fracture surfaces do not include discolored weathering along cleavage and parting surfaces. For example, a shear that carries weathering to great depths in a fresh rock mass would not require the same rock mass to be classified as weathered.

\*\* Combination categories are used where equal distribution of both weathering characteristics are present. One significant feature or where characteristics noted are "in between" the diagnostic characteristics.

## SEDIMENTARY AND PYROCLASTIC ROCK PARTICLE SIZES

Size in mm	Sedimentary		Pyroclastic
	Rock	Soil	
	Block Fragment	Block Fragment	Fragment Product
256	Boulder	Boulder conglomerate	Block or Boulder
64	Cobble	Cobble conglomerate	Block or Boulder conglomerate*
4	Gravel	Gravel conglomerate	Lapilli or Lapilli tuff
2	Very coarse sand	Sandstone	
0.5	Coarse sand		
0.25	Medium sand		Coarse ash
0.125	Fine sand	(Very coarse, coarse, medium, fine, or very fine)	Coarse silt
0.0625	Very fine sand		
0.03125	Silt	Siltstone/ Shale	Fine ash
	Clay	Claystone/ Shale	Fine tuff

\* Broken from previous fragment rock, block shaped (angular to subangular), or shattered from plastic material while in flight, rounded clasts.

## BEDDING FOLIATION OR FLOW TEXTURE

DESCRIPTIONS	THICKNESS/SPACING
<b>MODERATELY TO HEAVILY FOLDED (or banded)</b>	Greater than 10 ft (3 m)
<b>MODERATELY FOLDED (or banded)</b>	5 to 10 ft (1.5 to 3 m)
<b>MODERATELY TO HEAVILY FOLDED (or banded)</b>	1 to 5 ft (300 mm to 1.5 m)
<b>MODERATELY TO HEAVILY FOLDED (or banded)</b>	0.5 to 1 ft (100 to 300 mm)
<b>MODERATELY TO HEAVILY FOLDED (or banded)</b>	0.1 to 0.5 ft (30 to 150 mm)
<b>MODERATELY TO HEAVILY FOLDED (or banded)</b>	0.05 to 0.1 ft (10 to 30 mm)
<b>MODERATELY TO HEAVILY FOLDED (or banded)</b>	Less than 0.05 ft (10 mm)

## BEDROCK HARDNESS / STRENGTH

**EXTREMELY HARD (E0):** Core, fragment or exposure cannot be scratched with knife or sharp pick; can only be chipped with repeated heavy hammer blows.

**VERY HARD (E1):** Cannot be scratched with knife or sharp pick. Core or fragment breaks with repeated heavy hammer blows.

**HARD (E2):** Can be scratched with knife or sharp pick with difficulty. Core or fragment breaks with repeated heavy hammer blows.

**MODERATELY HARD (E3):** Can be scratched with knife or sharp pick with light or moderate pressure. Core or fragment breaks with moderate hammer blows.

**MODERATELY SOFT (E4):** Can be scratched with knife or sharp pick with light or moderate pressure. Core or fragment breaks with light hammer blow or heavy manual pressure.

**SOFT (E5):** Can be grooved or gouged easily by knife or sharp pick with light pressure. Core or fragment breaks with light manual pressure.

**VERY SOFT (E6):** Can be readily indented, grooved or gouged with fingernail, or carved with a knife. Breaks with light manual pressure.

**NOTE:** Bedrock units softer than E0, very soft, are described using USEE (soils) consistency descriptions.

## IGNEOUS AND METAMORPHIC ROCK TEXTURE

TEXTURE DESCRIPTION	AVERAGE GRAIN DIAMETER
<b>VERY COARSE GRAINED OR PORPHYRY</b>	> 10 mm (> 3/8 in.)
<b>COARSE GRAINED</b>	1-10 mm (2/32 - 3/8 in.)
<b>MEDIUM GRAINED</b>	1/4-1 mm (1/32 - 3/16 in.)
<b>FINE GRAINED</b>	0.1-1 mm (1/64 - 1/16 in.)
<b>CRYSTALLINE</b> (cannot be seen with the unaided eye)	< 0.1 mm (< 0.004 in.)

## ADDITIONAL TEXTURAL ADJECTIVES

**PIT (pitted)** - Pinhole to 0.03 ft (3/8 in.) (< 1 to 10 mm) openings.

**VOID (voided)** - Small openings (usually lined with crystals) ranging in diameter from 0.03 ft (3/8 in.) to 0.33 ft (4 in.) (10 to 100 mm).

**CRISTY** - An opening larger than 0.33 ft (4 in.) (100 mm), size descriptions are required, and adjectives such as small, large, etc., may be used.

**NOTED:** - If necessary enough that only thin white opaque horizontal glass or wags, this term further describes the preceding nomenclature to indicate crystalline form.

**VESICLE (vacuolar)** - Small openings in volcanic rocks of variable shape and size formed by trapped gas bubbles during solidification.

## DURABILITY INDEX

DURABILITY DESCRIPTION	DESCRIPTIVE CRITERIA
<b>D00</b>	Rock specimen or exposure remains intact with no noticeable cracking after exposure longer than 1 year.
<b>D01</b>	Rock specimen or exposure develops hairline cracking on surfaces within 1 month, but no disintegration within 1 year of exposure.
<b>D02</b>	Rock specimen or exposure develops hairline cracking on surfaces within 1 week, and/or disintegration within 1 month of exposure.
<b>D03</b>	Specimen or exposure may develop hairline cracks in 1 day and display pronounced separation of bedding and/or disintegration within 1 week of exposure.
<b>D04</b>	Specimen or exposure displays pronounced cracking and disintegration within 1 day (10 hours) of exposure, generally reveals and/or breaks to small fragments.

## COLOR

The Munsell color system (Munsell Color Order Chart) is used. This system defines color by its hue, value, and chroma. Color names (i.e., 5 Y 7.5/2) may be included.

**ALWAYS THINK SAFETY**

UNITED STATES  
DEPARTMENT OF THE INTERIOR  
BUREAU OF RECLAMATION

**GEOLOGY FOR DESIGNS & SPECIFICATIONS  
STANDARD DESCRIPTORS AND DESCRIPTIVE  
CRITERIA FOR ROCK**

SECOND EDITION, 1998 TECHNICAL REPORT *Robert M. ...*  
CONTRIBUTORS: ...  
CHIEF: ...  
DESIGNER: ...

REVISED, 2004 OCTOBER 1, 2004 **40-D-6493**

Figure 4.6.—Descriptor legend and explanation example.

## FIELD MANUAL

## ROCKS

- Dominant discontinuity characteristics
  - Hardness and/or strength
  - Deformability
  - Deleterious minerals or beds (such as swelling susceptibility, sulfates, or clays)

For example, a Tertiary shale unit, Tsh, may be differentiated as Tsh<sub>1</sub> or Tsh<sub>2</sub> if unit 2 contains bentonite interbeds and unit 1 does not, and Tsh<sub>c</sub> could be used as a unit name for the bentonite beds. A chlorite schist unit, Cs, may be differentiated as Cs<sub>A</sub> or Cs<sub>B</sub> where unit A contains higher percentages of chlorite or talc and is significantly softer (different deformation properties) than unit B. A metasediment unit, ms, may be further differentiated on more detailed maps and logs as ms<sub>sh</sub> (shale) or ms<sub>ls</sub> (limestone). All differentiated units should be assigned distinctive map symbols and should be described on the General Geologic Legend, Explanation, and Notes drawings.

### **Descriptors and Descriptive Criteria for Physical Characteristics of Rock**

**Lithologic Descriptors (Composition, Grain Size, and Texture).**—Provide a brief lithologic description of the rock unit. This includes a general description of mineralogy, induration, cementation, crystal and grain sizes and shapes, textural adjectives, and color. Lithologic descriptors are especially important for the description of engineering geology subunits when rock unit names are not specific. Examples of rock unit names that are not specific are metasediments, Tertiary intrusives, or Quaternary volcanics.

## FIELD MANUAL

**1. Composition.**—Use standard adjectives such as sandy, silty, calcareous, etc. Detailed mineral composition generally is not necessary or desirable unless useful in correlating units or indicating pertinent engineering physical properties. Note unique features such as fossils, large crystals, inclusions, concretions, and nodules which may be used as markers for correlations and interpretations.

**2. Crystal or particle sizes and shapes.**—Describe the typical crystal or grain shapes and provide a description of sizes present in the rock unit based on the following standards:

- **Igneous and metamorphic rocks.**—Table 4-1 is recommended for descriptions of crystal sizes in igneous and metamorphic rocks. Crystal sizes given in millimeters (mm) are preferred rather than fractional inch (in) equivalents.

Table 4-1.—Igneous and metamorphic rock grain size descriptors

Descriptor	Average crystal diameter
Very coarse-grained or pegmatitic	> 10 mm (3/8 in)
Coarse-grained	5-10 mm (3/16 - 3/8 in)
Medium-grained	1-5 mm (1/32 - 3/16 in)
Fine-grained	0.1-1 mm (0.04 - 1/32 in)
Aphanitic (cannot be seen with the unaided eye)	<0.1 mm (<0.04 in)

- **Sedimentary and pyroclastic rocks.**—Terminology for particle sizes and their lithified products which form sedimentary and pyroclastic rocks is provided in table 4-2. The size



# ROCKS

Table 4-2.—Sedimentary and pyroclastic rock particle-size descriptors  
(AGI Glossary)

USGS (soils only) Particle size	Size in mm (inches)	Sedimentary (epiclastic) Rounded, subrounded, subangular		Volcanic (pyroclastic)	
		Particle or fragment	Lithified product	Fragment	Lithified product*
Boulder	300 (12)	Boulder	Boulder conglomerate	Block+	Volcanic breccia+
	256 (10)				
Cobble	75 (3)	Cobble	Cobble conglomerate	Bomb	Agglo- merate
	64 (2.5)				
Coarse gravel	32 (1.3)	Pebble	Pebble conglomerate	Lapilli	Lapilli tuff
	20 (0.8)				
Fine gravel	4.75 (0.19)				
	4 (0.16)				
Coarse sand	2 (0.08)	Granule	Granule conglomerate	Coarse ash	Coarse tuff
	Medium sand	1 (0.04)	Very coarse sand		
0.5 (0.02)		Coarse sand			
0.42		Medium sand			
0.25		Fine sand			
Fine sand	0.125	Very fine sand		Fine ash	Fine tuff
	0.074				
Fines Non- plastic Silt	0.0625	Silt	Siltstone Shale		
	0.0039	Clay	Claystone Shale		

+ Broken from previous igneous rock block shaped (angular to subangular).  
Solidified from plastic material while in flight, rounded clasts.

\* Refer to figure 4-4.

## FIELD MANUAL

limits do not correspond to the Unified Soil Classification System for soil particle size but are used for the field description and petrographic classification of rocks. These limits are the accepted sizes in geologic literature and are used by petrographic laboratories.

**3. Textural adjectives.**—Texture describes the arrangements of minerals, grains, or voids. These microstructural features can affect the engineering properties of the rock mass. Use simple, standard, textural adjectives or phrases such as porphyritic, vesicular, scoriaceous, pegmatitic, granular, well developed grains, dense, fissile, slaty, or amorphous. Use of terms such as holohyaline, hypidiomorphic granular, and crystalloblastic is inappropriate.

Textural terms which identify solutioning, leaching, or voids in bedrock are useful for describing primary texture, weathering, alteration, permeability, and density.

The terminology which follows defines sizes of voids, or holes in bedrock. However, when describing pits, vugs, cavities, or vesicles, a complete description which includes the typical diameter, or the "mostly" range, and the maximum size observed is required. For example:

". . . randomly oriented, elliptically shaped vugs range mostly from 0.03 to 0.06 foot (ft) in diameter, maximum size 0.2 foot; decreases in size away from quartz-calcite vein; about 15 percent contain calcite crystals. . ."

or

". . . cavity, 3.3 ft wide by 16.4 ft long by 2.3 ft high, striking N 45°W, dipping 85°SW was. . ."

## ROCKS

- **Pit (pitted).**—Pinhole to 0.03 ft [**d** in] (<1 to 10 mm) openings.
- **Vug (vuggy).**—Small opening (usually lined with crystals) ranging in diameter from 0.03 ft [**d** in] to 0.33 ft [4 in] (10 to 100 mm).
- **Cavity.**—An opening larger than 0.33 ft [4 in] (100 mm), size descriptions are required, and adjectives such as small, or large, may be used, if defined.
- **Honeycombed.**—Individual pits or vugs are so numerous that they are separated only by thin walls; this term is used to describe a cell-like form.
- **Vesicle (vesicular).**—Small openings in volcanic rocks of variable shape formed by entrapped gas bubbles during solidification.

**4. Color.**—As a minimum, provide the color of wet altered and unaltered or fresh rock. Reporting color for both wet and dry material is recommended since the colors may differ significantly and cause confusion. The Munsell Color System, as used in the Geologic Society of America Rock Color Chart [5], is used to provide standard color names and assist in correlation. The chart also provides uniform and identifiable colors to others. Color designators are optional unless necessary for clarity, e.g., light brown (5YR 5/6). Terms such as banded, streaked, mottled, speckled, and stained may be used to further describe color. Also describe colors of bands, etc.

**Bedding, Foliation, and Flow Texture.**—These features give the rock anisotropic properties or represent potential failure surfaces. Continuity and thickness of these features influence rock mass properties and cannot

## FIELD MANUAL

always be tested in the laboratory. Descriptors in table 4-3 are used to identify these thicknesses.

Table 4-3.—Bedding, foliation, or flow texture descriptors

Descriptors	Thickness/spacing
Massive	Greater than 10 ft (3 meters [m])
Very thickly, bedded, foliated, or banded	3 to 10 ft (1 to 3 m)
Thickly	1 to 3 ft (300 mm to 1 m)
Moderately	0.3 to 1 ft (100 to 300 mm)
Thinly	0.1 to 0.3 ft (30 to 100 mm)
Very thinly	0.03 [3/8 in] to 0.1 ft (10 to 30 mm)
Laminated (intensely foliated or banded)	Less than 0.03 ft [3/8 in] (<10 mm)

### **Weathering and Alteration.—**

**1. Weathering.**—Weathering, the process of chemical or mechanical degradation of rock, can significantly affect the engineering properties of the rock and rock mass. For engineering geology descriptions, the term "weathering" includes both chemical disintegration (decomposition) and mechanical disaggregation as agents of alteration.

Weathering effects generally decrease with depth, although zones of differential weathering can occur and may modify a simple layered sequence of weathering.

## ROCKS

Examples are: (1) differential weathering within a single rock unit, apparently due to relatively higher permeability along fractures; (2) differential weathering due to compositional or textural differences; (3) differential weathering of contact zones associated with thermal effects such as interflow zones within volcanics; (4) directional weathering along permeable joints, faults, shears, or contacts which act as conduits along which weathering agents penetrate more deeply into the rock mass; and (5) topographic effects.

Weathering does not correlate directly with specific geotechnical properties used for many rock mass classifications. However, weathering is important because it may be the primary criterion for determining depth of excavation, cut slope design, method and ease of excavation, and use of excavated materials. Porosity, absorption, compressibility, shear and compressive strengths, density, and resistance to erosion are the major engineering parameters influenced by weathering. Weathering generally is indicated by changes in the color and texture of the body of the rock, color, and condition of fracture fillings and surfaces, grain boundary conditions, and physical properties such as hardness.

Weathering is reported using descriptors presented in table 4-4, which divides weathering into categories that reflect definable physical changes due to chemical and mechanical processes. This table summarizes general descriptions which are intended to cover ranges in bedrock conditions. Weathering tables are generally applicable to all rock types; however, they are easier to apply to crystalline rocks and rocks that contain ferromagnesian minerals. Weathering in many sedimentary rocks will not always conform to the criteria established in

## FIELD MANUAL

table 4-4, and weathering categories may have to be modified for particular site conditions. However, the basic horizontal categories and descriptors presented can be used. Site-specific conditions, such as fracture openness, filling, and degree and depth of penetration of oxidation from fracture surfaces, should be identified and described.

**2. Alteration.**—Chemical alteration effects are distinct from chemical and mechanical degradation (weathering), such as hydrothermal alteration, may not fit into the horizontal suite of weathering categories portrayed in table 4-4. Oxides may or may not be present. Alteration is site-specific, may be either deleterious or beneficial, and may affect some rock units and not others at a particular site. For those situations where the alteration does not relate well to the weathering categories, adjusting the description within the framework of table 4-4 may be necessary. Many of the general characteristics may not change, but the degree of discoloration and oxidation in the body of the rock and on fracture surfaces could be very different. Appropriate descriptors, such as moderately altered or intensely altered, may be assigned for each alteration category. Alteration products, depths of alteration, and minerals should be described.

**3. Slaking.**—Slaking is another type of disintegration which affects engineering properties of rock. Terminology and descriptive criteria to identify this deleterious property are difficult to standardize because some materials air slake, many water slake, and some only slake after one or more wet-dry cycles. The Durability Index (DI) is a simplified method for describing slaking. Criteria for the index are based

# ROCKS

Table 4-4.—Weathering descriptors

Descriptors		Diagnostic features					General characteristics (strength, excavation, etc.)§
		Chemical weathering—Discoloration and/or oxidation		Mechanical weathering - Grain boundary conditions (disaggregation) primarily for granitics and some coarse-grained sediments	Texture and solutioning		
Alpha-numeric descriptor	Descriptive term	Body of rock	Fracture surfaces†		Texture	Solutioning	
W1	Fresh.	No discoloration, not oxidized.	No discoloration or oxidation.	No separation, intact (tight).	No change.	No solutioning.	Hammer rings when crystalline rocks are struck. Almost always rock excavation except for naturally weak or weakly cemented rocks such as siltstones or shales.
W2	Slightly weathered to fresh.*						
W3	Slightly weathered.	Discoloration or oxidation is limited to surface of, or short distance from, fractures; some feldspar crystals are dull.	Minor to complete discoloration or oxidation of most surfaces.	No visible separation, intact (tight).	Preserved.	Minor leaching of some soluble minerals may be noted.	Hammer rings when crystalline rocks are struck. Body of rock not weakened. With few exceptions, such as siltstones or shales, classified as rock excavation.
W4	Moderately to slightly weathered.*						
W5	Moderately weathered.	Discoloration or oxidation extends from fractures, usually throughout; Fe-Mg minerals are "rusty," feldspar crystals are "cloudy."	All fracture surfaces are discolored or oxidized.	Partial separation of boundaries visible.	Generally preserved.	Soluble minerals may be mostly leached.	Hammer does not ring when rock is struck. Body of rock is slightly weakened. Depending on fracturing, usually is rock excavation except in naturally weak rocks such as siltstone or shales.
W6	Intensely to moderately weathered.*						
W7	Intensely weathered.	Discoloration or oxidation throughout: all feldspars and Fe-Mg minerals are altered to clay to some extent; or chemical alteration produces in situ disaggregation, see grain boundary conditions.	All fracture surfaces are discolored or oxidized, surfaces friable.	Partial separation, rock is friable; in semiarid conditions granitics are disaggregated.	Texture altered by chemical disintegration (hydration, argillation).	Leaching of soluble minerals may be complete.	Dull sound when struck with hammer; usually can be broken with moderate to heavy manual pressure or by light hammer blow without reference to planes of weakness such as incipient or hairline fractures, or veinlets. Rock is significantly weakened. Usually common excavation.
W8	Very intensely weathered.						
W9	Decomposed.	Discolored or oxidized throughout, but resistant minerals such as quartz may be unaltered; all feldspars and Fe-Mg minerals are completely altered to clay.		Complete separation of grain boundaries (disaggregated).	Resembles a soil, partial or complete remnant rock structure may be preserved; leaching of soluble minerals usually complete.		Can be granulated by hand. Always common excavation. Resistant minerals such as quartz may be present as "stringers" or "dikes."

Note: This chart and its horizontal categories are more readily applied to rocks with feldspars and mafic minerals. Weathering in various sedimentary rocks, particularly limestones and poorly indurated sediments, will not always fit the categories established. This chart and weathering categories may have to be modified for particular site conditions or alteration such as hydrothermal effects; however, the basic framework and similar descriptors are to be used.

\* Combination descriptors are permissible where equal distribution of both weathering characteristics are present over significant intervals or where characteristics present are "in between" the diagnostic feature. However, dual descriptors should not be used where significant, identifiable zones can be delineated. When given as a range, only two adjacent terms may be combined (i.e., decomposed to lightly weathered or moderately weathered to fresh) are not acceptable.

† Does not include directional weathering along shears or faults and their associated features. For example, a shear zone that carried weathering to great depths into a fresh rock mass would not require the rock mass to be classified as weathered.

§ These are generalizations and should not be used as diagnostic features for weathering or excavation classification. These characteristics vary to a large extent based on naturally weak materials or cementation and type of excavation.

## FIELD MANUAL



## ROCKS

on time exposed and effects noted in the field (see table 4-5). These simplified criteria do not specify whether the specimen or exposure is wetted, dried, or subjected to cyclic wetting and drying, and/or freeze-thaw. When reporting slaking or durability, a complete description includes the test exposure conditions. For example, the material could be classified as having "characteristics of DI 3 upon drying." Slaking is not the same as the effects of bedding separation or disaggregation produced by stress relief.

Table 4-5.—Durability index descriptors

Alpha-numeric descriptor	Criteria
DI0	Rock specimen or exposure remains intact with no deleterious cracking after exposure longer than 1 year.
DI1	Rock specimen or exposure develops hairline cracking on surfaces within 1 month, but no disaggregation within 1 year of exposure.
DI2	Rock specimen or exposure develops hairline cracking on surfaces within 1 week and/or disaggregation within 1 month of exposure.
DI3	Specimen or exposure may develop hairline cracks in 1 day and displays pronounced separation of bedding and/or disaggregation within 1 week of exposure.
DI4	Specimen or exposure displays pronounced cracking and disaggregation within 1 day (24 hours) of exposure. Generally ravel and degrades to small fragments.

## FIELD MANUAL

A field test suitable for evaluating the degree and rate of slaking for materials, primarily clayey materials and altered volcanics, is described below. The slaking test evaluates the disaggregation of an intact specimen in water and reflects the fabric of the material, internal stresses, and character of the interparticle bonds.

To evaluate slaking behavior, immerse two intact specimens (pieces of core or rock fragments consisting of a few cubic inches or centimeters) in water. One piece should be at natural water content (wrapped jar sample) and one piece from an air-dried sample. Test results should be photographed with labels to identify specimens and exposure times.

Results of the evaluation should be reported for each specimen. Describe the behavior of the specimens as follows:

a. Volume changes.—The volume of the material reduced to individual particles should be estimated and compared to the initial volume of material. The degree of disaggregation is described using the following descriptive criteria:

None	No discernable disaggregation
Slight	Less than 5 percent of the volume disaggregated
Moderate	Between 5 and 25 percent of the volume disaggregated
Intense	More than 25 percent but less than the total volume disaggregated
Complete	No intact piece of the material remains

## ROCKS

b. Rate of slaking.—The following descriptors are used to identify the time to slake:

Slow slaking	Action continues for several hours
Moderate slaking	Action completed within 1 hour
Rapid slaking	Action completed within 2 minutes
Sudden slaking	Complete reaction, action completed instantaneously

[Generally, slaking applies to rock; disaggregation applies to soils.]

**4. Character of material.**—The character of the remaining pieces of material after the test is completed is described as follows:

No change	Material remains intact
Plates remain	Remaining material present as platy fragments of generally uniform thickness
Flakes remain	Remaining material present as flaky or wedge-shaped fragments
Blocks remain	Blocky fragments remain
Grains remain	Remaining material chiefly present as sand-size grains
No fragments	Remaining material entirely disaggregated to clay-size particles

**Hardness—Strength.**—Hardness can be related to intact rock strength as a qualitative indication of density and/or resistance to breaking or crushing. Strength is a necessary engineering parameter for design that

## FIELD MANUAL

frequently is not assessed, but plays a role in engineering design and construction, such as tunnel support requirements, bit wear for drilling or tunnel boring machine (TBM) operations, allowable bearing pressures, excavation methods, and support.

The hardness and strength of intact rock is a function of the individual rock type but may be modified by weathering or alteration. Hardness and strength are described for each geologic unit when they are functions of the rock type and also for zones of alteration or weathering when there are various degrees of hardness and/or strength due to different degrees of weathering or chemical alteration. When evaluating strengths, it is important to note whether the core or rock fragments break around, along, or through grains; or along or across incipient fractures, bedding, or foliation.

Hardness and especially strength are difficult characteristics to assess with field tests. Two field tests can be used; one is a measure of the ability to scratch the surface of a specimen with a knife, and the other is the resistance to fracturing by a hammer blow. Results from both tests should be reported. The diameter and length of core or the fragment size will influence the estimation of strength and should be kept in mind when correlating strengths. A 5- to 8-inch (130- to 200-mm) length of N-size core or rock fragment, if available, should be used for hardness determinations to preclude erroneously reporting point, rather than average hardness, and to evaluate the tendency to break along incipient fractures and textural or structural features when struck with a rock pick. Standards (heavy, moderate, and light hammer blow) should be calibrated with other geologists mapping or logging core for a particular project. Descriptors used for rock hardness/strength are shown on table 4-6.

## ROCKS

Table 4-6.—Rock hardness/strength descriptors

Alpha- numeric descriptor	Descriptor	Criteria
H1	Extremely hard	Core, fragment, or exposure cannot be scratched with knife or sharp pick; can only be chipped with repeated heavy hammer blows.
H2	Very hard	Cannot be scratched with knife or sharp pick. Core or fragment breaks with repeated heavy hammer blows.
H3	Hard	Can be scratched with knife or sharp pick with difficulty (heavy pressure). Heavy hammer blow required to break specimen.
H4	Moderately hard	Can be scratched with knife or sharp pick with light or moderate pressure. Core or fragment breaks with moderate hammer blow
H5	Moderately soft	Can be grooved 1/16 inch (2 mm) deep by knife or sharp pick with moderate or heavy pressure. Core or fragment breaks with light hammer blow or heavy manual pressure.
H6	Soft	Can be grooved or gouged easily by knife or sharp pick with light pressure, can be scratched with fingernail. Breaks with light to moderate manual pressure.
H7	Very soft	Can be readily indented, grooved or gouged with fingernail, or carved with a knife. Breaks with light manual pressure.

Any bedrock unit softer than H7, very soft, is to be described using USBR 5000 consistency descriptors.

Note: Although "sharp pick" is included in these definitions, descriptions of ability to be scratched, grooved, or gouged by a knife is the preferred criteria

A few empirical and quantitative field techniques which are quick, easy, and inexpensive are available to provide strength estimates. Quantitative strength estimates can

## FIELD MANUAL

be obtained from the point load test. A lightweight and portable testing device is used to break a piece of core (with a minimum length at least 1.5 times the diameter) between two loading points. If a new fracture does not run from one loading point to the other upon completion of the test, or if the points sink into the rock surface causing excessive deformation or crushing, the test should not be recorded. Raw data are given with the reduced data (equations to empirically convert load data to compressive strengths are usually supplied with the equipment). The Schmidt (*L*) hammer may also be used for estimating rock strengths; refer to Field Index Tests in chapter 5. Each of these tests can be used to calibrate the manual index (empirical) properties described in table 4-6, and a range of compressive strengths can be assigned. Depending on the scope of the study and structure being considered, laboratory testing may be required and used to confirm the field test data.

**Discontinuities.**—Describe all discontinuities such as joints, fractures, shear/faults, and shear/fault zones, and significant contacts. These descriptions should include all observable characteristics such as orientation, spacing, continuity, openness, surface conditions, and fillings. Appropriate terminology, descriptive criteria and descriptors, and examples pertaining to discontinuities are presented in chapter 5.

**Contacts.**—Contacts between various rock units or rock/soil units must be described. In addition to providing a geologic classification, describe the engineering characteristics such as the planarity or irregularity and other descriptors used for discontinuities.

Descriptors applicable to the geologic classification of contacts are:

## ROCKS

- Conformable
- Unconformable
- Welded—contact between two lithologic units, one of which is igneous, that has not been disrupted tectonically
- Concordant (intrusive rocks)
- Discordant (intrusive rocks)

Descriptors pertinent to engineering classification of contacts are:

- Jointed—contact not welded, cemented, or healed—a fracture
- Intact
- Healed (by secondary process)
- Sharp
- Gradational
- Sheared
- Altered (baked or mineralized)
- Solutioned

If jointed or sheared, additional discontinuity descriptors such as thickness of fillings, openness, moisture, and roughness, should be provided also (see discontinuity descriptors in chapter 5).

**Permeability Data.**—Permeability (hydraulic conductivity) is an important physical characteristic that must be described. Suggested methods for testing, terminology, and descriptors are available in the *Earth Manual* and *Ground Water Manual*. Numerical values for hydraulic conductivity (K) can be determined using any of several methods. These values may be shown on drill hole logs. For narrative discussions or summary descriptions, the numerical value and descriptors may be used. Descriptors to be used—such as low,

## FIELD MANUAL

moderate—are those shown on figure 4-7. Whether permeability is primary (through intact rock) or secondary (through fractures) should be indicated.

### Example Descriptions

The examples which follow are in representative formats for describing bedrock in the physical conditions column of drill hole logs and on a legend, explanation, and notes drawing.

### Core Log Narrative

Several examples of descriptions for core logs are presented. These examples illustrate format and the use of the lithologic descriptors but do not include a description of discontinuities.

### Log with Alphanumeric Descriptors and English Units.—

. . . 12.6 to 103.6: Amphibolite Schist (JKam). Fine-grained (0.5 to 1 mm); subschistose to massive; greenish-black (5G 2/1) with numerous blebs and stringers of white calcite to 0.02 ft thick with solution pits and vugs to 0.03 ft, mostly 0.01 ft, aligned subparallel to foliation; very thinly foliated, foliation dips 65° to 85°, steepening with depth. Moderately to slightly weathered (W4), iron oxide staining on all discontinuities. Hard (H3), can be scratched with knife with heavy pressure, core breaks parallel to foliation with heavy hammer blow. Slightly fractured (FD3),. . .



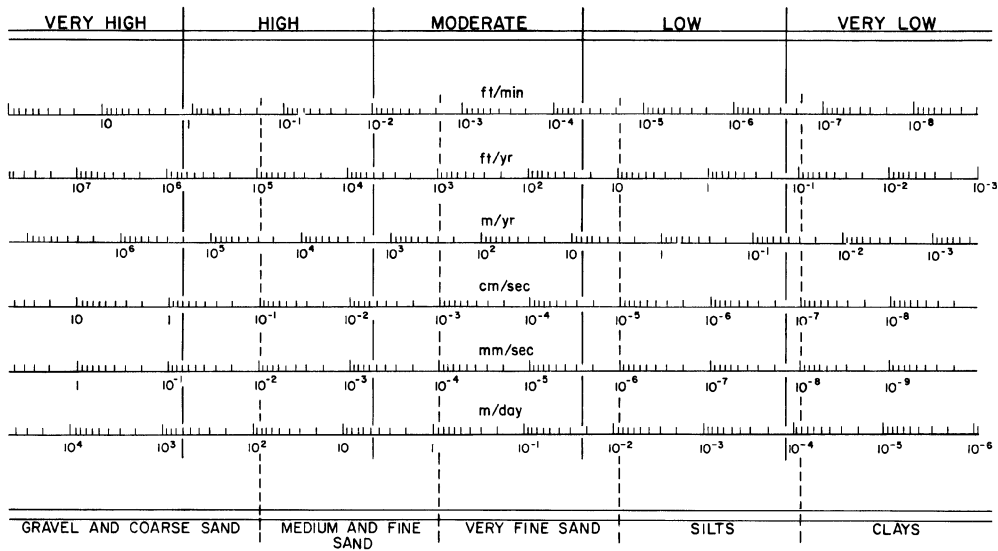


Figure 4-7.—Permeability conversion chart.

## FIELD MANUAL

### Log with Alphanumeric Descriptors Using Metric Units.—

103.60 to 183.22: Sandstone (TU<sub>sa</sub>). Ferruginous quartzose sandstone. Medium-grained (0.25 to 0.5 mm), well sorted, subrounded to rounded quartz grains are well cemented by silica; hematite occurs as minor cement agent and as thin coating on grains. Moderate reddish-brown (10R 6/6). Moderately bedded, beds 250 to 310 mm thick, bedding dips 15° to 29°, averages 18°. Slightly weathered. Hard, cannot be scratched with knife, core breaks with heavy hammer blow across bedding and through grains. Moderately fractured. Core recovered. . .

172.41-176.30: Claystone (TU<sub>c2</sub>). Calcareous montmorillonitic clay with 20 percent subangular, fine sand-size quartz fragments. Strong reaction with hydrochloric acid (HCl), grayish pink (5R 8/2). Moderately to rapidly slaking when dropped in water. Very thinly bedded to laminated with bed thickness from 8 to 20 mm. Very intensely weathered. Very soft, can be gouged with fingernail, friable, core breaks with manual pressure, smaller fragments can be crushed with fingers. . . Upper contact is parallel to bedding, conformable, gradational, and intact; lower contact is unconformable, sharp and jointed but tight; dips 35°  
. . . .

### Legend

The example which follows could be typical of a rock unit description on a general legend, explanation, and note drawing. The object is to describe as many physical properties as possible which apply to the entire rock unit at the site. If individual subunits can be differentiated, they could be assigned corresponding symbols and

## ROCKS

described below the undifferentiated description. Those characteristics in the subunits which are similar or are included in the undifferentiated unit do not need to be repeated for each subunit.

**Amphibolite Schist - Undifferentiated.**—Mineralogy variable but generally consists of greater than 30 percent amphibole. Contains varying percentages of feldspar, quartz, and epidote in numerous, thin, white and light green (5G 7/4), discontinuous stringers and blebs. Texture ranges from fine grained and schistose to medium grained and subschistose. Overall, color ranges from greenish black (5G 2/1) to olive black (5Y 2/1). Thinly foliated; foliation dips steeply 75° to 85° NE. Weathering is variable but generally moderately weathered to depths of 75 ft, slightly weathered to 120 ft, and fresh below. Where oxidized, moderate reddish-brown (10R 4/6), frequently with dendritic patterns of oxides on discontinuities. Hard, fresh rock can be scratched slightly with heavy knife pressure; fresh N-size core breaks along foliation with moderate to heavy hammer blow. Foliation joints are variably spaced and discontinuous, spaced more closely where weathered. Joint sets are prominent but discontinuous. (Joint sets are identified in the specifications paragraphs). Commonly altered 0.1 to 6 ft along contacts of dikes and larger shears with epidote and quartz ("altered amphibolite" on logs of exploration). When altered, harder than amphibolite. Based on drill hole permeability testing, hydraulic conductivity is very low to low, with values ranging from 0.09 to 130 feet per year (ft/yr) averages 1.5 ft/yr in slightly weathered and fresh rock.

## FIELD MANUAL

### BIBLIOGRAPHY

- [1] Travis, Russell B., "Classification of Rocks," v. 50, No. 1, Quarterly of the Colorado School of Mines, Golden, CO, January 1955.
- [2] Fisher, R.V., "Rocks Composed of Volcanic Fragments: *Earth Science Review*, v. I, pp. 287-298, 1966.
- [3] Williams, H., and McBirney, A., *Volcanology*, published by Freeman, Cooper and Company, San Francisco, CA. 391 pp., 1979.
- [4] Compton, Robert R., *Geology in the Field*, published by John Wiley & Sons, Inc., New York, NY, 1985.
- [5] Geological Society of America Rock Color Chart, 8th printing, 1995.

## Chapter 5

# TERMINOLOGY AND DESCRIPTIONS FOR DISCONTINUITIES

### General

Structural breaks or discontinuities generally control the mechanical behavior of rock masses. In most rock masses the discontinuities form planes of weakness or surfaces of separation, including foliation and bedding joints, joints, fractures, and zones of crushing or shearing. These discontinuities usually control the strength, deformation, and permeability of rock masses. Most engineering problems relate to discontinuities rather than to rock type or intact rock strength. Discontinuities must be carefully and adequately described. This chapter describes terminology, indexes, qualitative and quantitative descriptive criteria, and format for describing discontinuities. Many of the criteria contained in this chapter are similar to criteria used in other established sources which are accepted as international standards (for example, *International Journal of Rock Mechanics*, 1978 [1]).

### Discontinuity Terminology

The use of quantitative and qualitative descriptors requires that what is being described be clearly identified. Nomenclature associated with structural breaks in geologic materials is frequently misunderstood. For example, bedding, bedding planes, bedding plane partings, bedding separations, and bedding joints may have been used to identify similar or distinctly different geological features. The terminology for discontinuities which is presented in this chapter should be used uniformly for all geology programs. Additional definitions for various types of discontinuities are presented in the *Glossary of Geology* [2]; these may be used to further describe structural breaks. The following basic definitions should not be modified unless clearly justified, and defined.

## FIELD MANUAL

**Discontinuity.**—A collective term used for all structural breaks in geologic materials which usually have zero to low tensile strength. Discontinuities also may be healed. Discontinuities comprise fractures (including joints), planes of weakness, shears/faults, and shear/fault zones. Depositional or erosional contacts between various geologic units may be considered discontinuities. For discussion of contacts, refer to chapter 4.

**Fracture.**—A term used to describe any natural break in geologic material, excluding shears and shear zones. Examples of the most common fractures are defined as follows:

**1. Joint.**—A fracture which is relatively planar along which there has been little or no obvious displacement parallel to the plane. In many cases, a slight amount of separation normal to the joint surface has occurred. A series of joints with similar orientation form a joint set. Joints may be open, healed, or filled; and surfaces may be striated due to minor movement. Fractures which are parallel to bedding are termed bedding joints or bedding plane joints. Those fractures parallel to metamorphic foliation are called foliation joints.

**2. Bedding plane separation.**—A separation along bedding planes after exposure due to stress relief or slaking.

**3. Random fracture.**—A fracture which does not belong to a joint set, often with rough, highly irregular, and nonplanar surfaces along which there has been no obvious displacement.

**4. Shear.**—A structural break where differential movement has occurred along a surface or zone of

## DISCONTINUITIES

failure; characterized by polished surfaces, striations, slickensides, gouge, breccia, mylonite, or any combination of these. Often direction of movement, amount of displacement, and continuity may not be known because of limited exposures or observations.

**5. *Fault*.**—A shear with significant continuity which can be correlated between observation locations; foundation areas, or regions; or is a segment of a fault or fault zone reported in the literature. The designation of a fault or fault zone is a site-specific determination.

**6. *Shear/fault zone*.**—A band of parallel or subparallel fault or shear planes. The zone may consist of gouge, breccia, or many fault or shear planes with fractured and crushed rock between the shears or faults, or any combination. In the literature, many fault zones are simply referred to as faults.

**7. *Shear/fault gouge*.**—Pulverized (silty, clayey, or clay-size) material derived from crushing or grinding of rock by shearing, or the subsequent decomposition or alteration. Gouge may be soft, uncemented, indurated (hard), cemented, or mineralized.

**8. *Shear/fault breccia*.**—Cemented or uncemented, predominantly angular (may be platy, rounded, or contorted) and commonly slickensided rock fragments resulting from the crushing or shattering of geologic materials during shear displacement. Breccia may range from sand-size to large boulder-size fragments, usually within a matrix of fault gouge. Breccia may consist solely of mineral grains.

**9. *Shear/fault-disturbed zone*.**—An associated zone of fractures and/or folds adjacent to a shear or

## FIELD MANUAL

shear zone where the country rock has been subjected to only minor cataclastic action and may be mineralized. If adjacent to a fault or fault zone, the term is fault-disturbed zone. Occurrence, orientation, and areal extent of these zones depend upon depth of burial (pressure and temperature) during shearing, brittleness of materials, and the in-place stresses.

Terminology for joint (JT), foliation joint (FJ), bedding joint (BJ), incipient joint (IJ) or incipient fracture (IF), random fracture (RF), mechanical break (MB), and fracture zone (FZ) is given on figure 5-9 (drawing No. 40-D-6499 following later in this chapter). Suggested abbreviations are in parentheses.

### **Indexes for Describing Fracturing**

#### **Fracture Density**

Fracture density is based on the spacing between all natural fractures in an exposure or core recovery lengths from drill holes, excluding mechanical breaks, shears, and shear zones; however, shear-disturbed zones (fracturing outside the shear) are included. In this context, fracture is a general term and includes all natural breaks such as joints, bedding joints, foliation joints, and random fractures. Fracture density should always be described in physical measurements, but summary descriptive terms relating to these measurements are a convenient aid in communicating characteristics of the rock mass. Standard descriptors apply to all rock exposures, such as tunnel walls, dozer trenches, outcrops, or foundation cut slopes and inverts, as well as boreholes. Fracture



## DISCONTINUITIES

descriptors presented in table 5-1 and figure 5-9 are based on drill hole cores where lengths are measured along the core axis.

When describing fracture density, a percentage of the types of fractures should be provided. A complete description for fracture density might read: Slightly Fractured (FD3), recovered core in 0.8- to 4.7-feet (0.2- to 1.4-meter [m]) lengths, mostly 1.7 feet (520 millimeters [mm]), 25 percent bedding joints/75 percent joints.

### **Fracture Frequency**

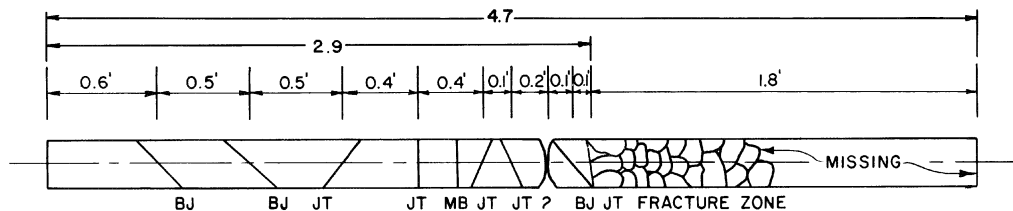
Fracture frequency is the number of fractures occurring within a unit length. The number of natural fractures is divided by the length and is reported as fractures per foot or fractures per meter.

### **Rock Quality Designation**

Rock Quality Designation (RQD) [2] is a fracture index used in many rock classification systems. To determine the RQD value, add the total length of solid core that is 4 inches (100 mm) or more long regardless of core diameter. If the core is broken by handling or the drilling process (mechanical breaks), the broken pieces are fitted together and counted as one piece, provided that they form the requisite length of 4 inches (100 mm). The length of these pieces is measured along the centerline of the core. This sum is divided by the length of the run (drill interval) and recorded on the log as a percentage of each run. Figure 5-1 illustrates RQD measurements and procedures.

RQD estimates can be determined from outcrops.  $RQD = 115 - 3.3 J_v$  where  $J_v$  equals the total number of joints in a cubic meter. RQD may also be estimated from an

1. PERCENTAGE OF SOLID CORE SEGMENTS LONGER THAN 0.33 ft (100mm) RELATIVE TO CORE RUN LENGTH, EXCLUDING MECHANICAL BREAKS.
2. RECORDED AS CALCULATED PERCENTAGE FOR EACH RUN.
3. BEST FOR N-SIZE OR LARGER SIZE CORE.
4. MAY NOT BE APPLICABLE FOR VERY LOW STRENGTH, FISSILE OR FOLIATED ROCKS WHICH BREAK OR PART EASILY.



$$RQD = \frac{\text{Sum of length of pieces } \geq 0.33 \text{ ft (4in)}}{\text{(total length of core run)}} \times 100 = \frac{2.4}{4.7} \times 100 = 51\%$$

**Figure 5-1.—Rock Quality Designation (RQD) computation.**

## DISCONTINUITIES

Table 5-1.—Fracture density descriptors

Alpha- numeric descriptor	Descriptor	Criteria (excludes mechanical breaks)
FD0	Unfractured	No observed fractures.
FD1	Very slightly fractured	Core recovered mostly in lengths greater than 3 feet (1 m).
FD2	Slightly to very slightly fractured	
FD3	Slightly fractured	Core recovered mostly in lengths from 1 to 3 feet (300 to 1,000 mm) with few scattered lengths less than 1 foot (300 mm) or greater than 3 feet (1,000 mm).
FD4	Moderately to slightly fractured <sup>1</sup>	
FD5	Moderately fractured	Core recovered mostly in lengths from 0.33 to 1.0 foot (100 to 300 mm) with most lengths about 0.67 foot (200 mm).
FD6	Intensely to moderately fractured <sup>1</sup>	
FD7	Intensely fractured	Lengths average from 0.1 to 0.33 foot (30 to 100 mm) with fragmented intervals. Core recovered mostly in lengths less than 0.33 foot (100 mm).
FD8	Very intensely to intensely fractured <sup>1</sup>	
FD9	Very intensely fractured	Core recovered mostly as chips and fragments with a few scattered short core lengths.

<sup>1</sup> Combinations of fracture densities are permissible where equal distribution of both fracture density characteristics are present over a significant core interval or exposure, or where characteristics are "in between" the descriptor definitions.

## FIELD MANUAL

outcrop by determining the sum of solid rock (fracture free) in lengths 4 inches long or greater along a line that simulates either a 5- or 10-foot "core run." Detail line surveys provide the data needed to calculate RQD. Orienting the lines in different directions reduces directional bias. Either of these methods offers an advantage over RQDs determined from drill core, because all fracture orientations are included. Also, these RQD values more realistically represent rock conditions.

### **Description of Fractures**

An accurate description of fractures is as important as the physical characteristics of the rock mass. Fractures affect and usually control the strength, deformation, and permeability characteristics of a rock mass. Fractures are grouped into sets based on similar orientations, and each set is labeled and described. Along with the physical measurements, such as attitude, spacing, and continuity, include information such as composition, thickness, and hardness of fillings or coatings; characteristics of surfaces such as hardness, roughness, waviness, and alteration; healing; fracture openness; and presence of water or water flow. Joint and fracture properties also may be useful for correlating purposes. Cleavage (CL) in metamorphic rocks includes slaty cleavage, crenulation cleavage, phyllitic structure, and schistosity (after Davis [4]) and often can be used to evaluate the tectonic setting.

Figure 5-9 may be used for geologic reports or specifications where the standard descriptors and terminology established for discontinuities are used during data collection.

## DISCONTINUITIES

### Format for the Description of Fractures

Identifying and recording the physical characteristics of fractures during mapping and logging is the least expensive part of most geologic investigations. An accurate and concise description of these characteristics permits interpretation in geologic terms directly applicable to design and construction. As many of the characteristics should be described as possible, limited only by the type of observation. For example, continuity and waviness cannot be provided for joints observed in core. Examples of fracture descriptions recorded for a drill hole log and for an outcrop or exposure are in a following section. A general format for recording fracture descriptions follows:

- Orientation
- Spacing
- Continuity
- Openness
- Fillings
  - Thickness
  - Composition
  - Weathering/alteration
  - Hardness
- Healing
- Surfaces
  - Roughness
  - Waviness
  - Weathering/alteration
  - Hardness
- Field index test results
- Moisture

## FIELD MANUAL

### Descriptors for Fracture Characteristics

The following paragraphs present terminology, descriptor criteria, and descriptors for recording fracture data. Alphanumeric descriptors are amenable to computer sorting. Alphanumeric descriptors are not a substitute for a complete description of the fracture characteristics.

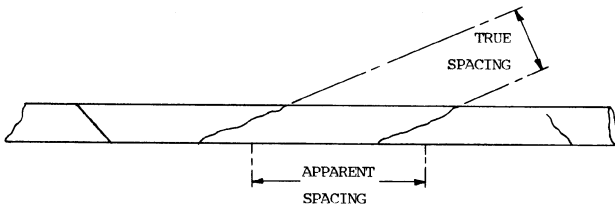
**Orientation.**—The orientation of all fractures with respect to applied loads can be critical to deformation or stability. Seepage or grouting also may be affected or controlled by orientation. Orientation is usually measured in the field, and the raw data tabulated and interpreted. The analysis typically includes stereonet, contour diagrams, fracture sets, and their areal distribution. A detailed statistical analysis of the fracture data may be necessary. Azimuths or quadrants may be used, but azimuths are becoming the standard, in part because they are easier to computerize. The American right-hand rule for dip direction notation is preferred. The method of measuring the dip of planar discontinuities, foliation, and bedding in cores is shown in figure 5-9. Figures 5-1 and 5-2 illustrate how inclination of a joint in core from an angle hole can be interpreted as a horizontal joint (A) or vertical joint (B) by rotating the core 180 degrees ( $^{\circ}$ ). If the core is oriented and the top of the core is known, the inclination can be recorded as positive (+) or negative (-) to avoid ambiguity and to assist in determining sets.

Fracture orientation is recorded as strike and dip, or as azimuth and dip, preferably using the right-hand rule. Orientation of planar features with undetermined strike can be measured directly and reported as dip in vertical holes. In angle holes, where true dip is not known, the angle of the plane should be measured from the core axis

## DISCONTINUITIES

and reported as inclination, i.e., "bedding plane joints inclined 65 degrees from the core axis."

**Spacing.**—Spacing affects block size and geometry in the rock mass. Spacing is a required input to several rock mass classification systems. When a set can be distinguished (parallel or subparallel joints), true spacing can be measured and is described for each joint set, as shown on figure 5-2 and in table 5-2. If apparent spacing is given, label as such.



**Figure 5-2.—Comparison of true and apparent spacing.**

**Continuity.**—A continuous joint or fracture is weaker and more deformable than a short discontinuous fracture bridged by intact bedrock. Recording trace lengths to describe continuity is useful in large exposures. Identification of the more continuous fractures is an important aspect of formulating rock stability input data, especially for high cut slopes and in large underground openings. Record the longest observable trace regardless of end type and note whether it is a strike (S), dip (D), or apparent (A) trace. Descriptors for continuity are provided in table 5-3.

## FIELD MANUAL

Table 5-2.—Fracture spacing descriptors

Alpha- numeric descriptor	Joint or fracture spacing descriptor	True spacing
SP1	Extremely widely spaced	Greater than 10 feet (ft) (<3 m)
SP2	Very widely spaced	3 to 10 ft (1 to 3 m)
SP3	Widely spaced	1 to 3 ft (300 mm to 1 m)
SP4	Moderately spaced	0.3 to 1 ft (100 to 300 mm)
SP5	Closely spaced	0.1 to 0.3 ft (30 to 100 mm)
SP6	Very closely spaced	Less than 0.1 ft (<30 mm)

Table 5-3.—Fracture continuity descriptors

Alpha- numeric descriptor	Descriptor	Lengths
C1	Discontinuous	Less than 3 ft (>1 m)
C2	Slightly continuous	3 to 10 ft (1 to 3 m)
C3	Moderately continuous	10 to 30 ft (3 to 10 m)
C4	Highly continuous	30 to 100 ft (10 to 30 m)
C5	Very continuous	Greater than 100 ft (>30 m)

This information alone is not sufficient to completely assess joint or fracture continuity because trace lengths may be partially obscured. When performing joint studies or surveys, record the number of ends (fracture terminations) that can be seen in the exposure using the alphanumeric descriptors shown in table 5-4. The size of the exposure should be noted because this is a determining factor when surveying for visible ends.



## DISCONTINUITIES

Table 5-4.—Descriptors for recording fracture ends in joint surveys

Alpha-numeric descriptor	Criteria
E0	Zero ends leave the exposure (both ends of the fracture can be seen in the exposure).
E1	One end can be seen (one end of the fracture terminates in the exposure).
E2	Both ends cannot be observed (two fracture ends do not terminate in the exposure).

**Openness.**—The width or aperture is measured normal to the fracture surface. This aperture or openness affects the strength, deformability, and seepage characteristics. Describe fracture openness by the categories shown in table 5-5. For drill logs, if actual openness cannot be measured or estimated, use only open or tight and do not assign an alphanumeric descriptor.

**Characteristics of Fracture Fillings.**—Describing the presence or absence of coatings or fillings and distinguishing between types, alteration, weathering, and strength and hardness of the filling material may be as significant as fracture spatial relationships or planarity. Strength and permeability of fractures may be affected by fillings. Descriptions of fracture coatings and fillings are site specific but must address the following considerations:

- 1. Thickness of fillings.**—Table 5-6 provides descriptors for recording the thickness of fracture fillings or coatings.

## FIELD MANUAL

Table 5-5.—Fracture openness descriptors

Alpha-numeric descriptor	Descriptor	Openness
O0	Tight	No visible separation
O1	Slightly open	Less than 0.003 ft [1/32 inch (in)] (<1 mm)
O2	Moderately open	0.003 to 0.01 ft [1/32 in to 1/8 in] (1 to 3 mm)
O3	Open	0.01 to 0.03 ft [1/8 to 3/8 in] (3 to 10 mm)
O4	Moderately wide	0.03 ft [3/8 in] to 0.1 ft (10 to 30 mm)
O5	Wide	Greater than 0.1 ft (>30 mm) (record actual openness)

Table 5-6.—Fracture filling thickness descriptors

Alpha-numeric descriptor	Descriptor	Thickness
T0	Clean	No film coating
T1	Very thin	Less than 0.003 ft [1/32 in] (<1 mm)
T2	Moderately thin	0.003 to 0.01 ft [1/32 to 1/8 in] (1 to 3 mm)
T3	Thin	0.01 to 0.03 ft [1/8 to 3/8 in] (3 to 10 mm)
T4	Moderately thick	0.03 ft [3/8 in] to 0.1 ft (10 to 30 mm)
T5	Thick	Greater than 0.1 ft (>30 mm) (record actual thickness)

## DISCONTINUITIES

**2. Composition of fillings.**—The mineralogical classification of fillings, such as quartz, gypsum, and carbonates, must be identified to convey physical properties of fractures that may be significant criteria for design. Soil materials in open fractures should be described and classified according to the Unified Soil Classification System (USCS) (see USBR 5000 and USBR 5005 [5]).

Fractures may be filled or "healed" entirely or over a significant portion of their areal extent by quartz, calcite, or other minerals. Veins may be present without healing the fracture or may have been broken again forming new surfaces. Soluble fillings, such as gypsum, may cause foundation or structural degradation during the facility's expected lifetime. Fracture fillings must be considered during design, construction investigations, and monitoring or potential long-term stability, deformability, and seepage problems may require expensive rehabilitation efforts.

Coatings or fillings of chlorite, talc, graphite, or other low-strength materials need to be identified because of their deleterious effects on strength, especially when wet. Some fillings, such as dispersive, erosive, or micaceous materials, can squeeze, pipe under fluid flow, and contribute to a loss of strength and stability. Montmorillonitic clays may swell or cause swelling pressures. Cohesionless materials, such as sands and silts, or materials which have been crushed or altered may run or flow into underground excavations or serve as seepage conduits.

## FIELD MANUAL

**3. *Weathering or alteration.***—Descriptors for weathering or alteration of fracture fillings (excluding soil materials) are the same as those used for rock weathering.

**4. *Hardness/strength.***—Descriptors for hardness/strength of fillings should be the same as those presented for bedrock hardness or soil consistency (chapters 3 and 4). Various field index tests may also be performed to determine strengths of fillings. Refer to the Field Index Tests in chapter 4.

**5. *Healing.***—Fractures may be healed or recemented by one or more episodes of mineralization or precipitation of soluble materials. A description of fracture healing or rehealing should include not only the type of healing or cementing agent, but an estimate of the degree to which the fracture has been healed. The subjective criteria and descriptors shown in table 5-7 should be used to describe healing.

**Characteristics of Fracture Surfaces.**—The physical characteristics of fracture surfaces are very important for deformability and stability analyses. Dimensional characteristics such as roughness and waviness (see figure 5-3) and characteristics, such as weathering and hardness of the surfaces, are important in evaluating the shear strength of fractures. Fracture roughness descriptors are given in table 5-8. Surface characteristics are less important only when low-strength materials comprise fracture fillings.

The description of fracture asperities is divided into two categories: small-scale asperities, or roughness, and large-scale undulations, or waviness. Figure 5-3 shows

## DISCONTINUITIES

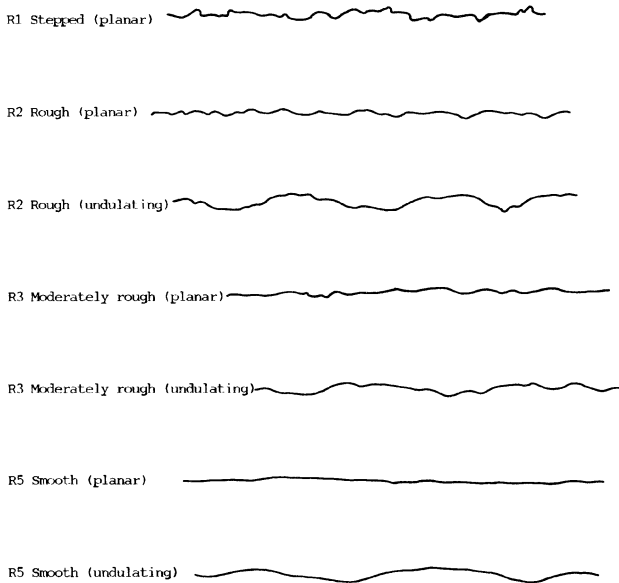
Table 5-7.—Fracture healing descriptors

Alpha-numeric descriptor	Descriptor	Criteria
HL0	Totally healed	Fracture is completely healed or recemented to a degree at least as hard as surrounding rock.
HL2	Moderately	Greater than 50 percent of fracture material, fracture surfaces, or healed filling is healed or recemented; and/or strength of the healing agent is less hard than surrounding rock.
HL3	Partly healed	Less than 50 percent of fractured material, filling, or fracture surface is healed or recemented.
HL5	Not healed	Fracture surface, fracture zone, or filling is not healed or recemented; rock fragments or filling (if present) is held in place by its own angularity and/or cohesiveness.

examples of these asperities. Descriptors for roughness and waviness and additional items related to fracture surfaces follow.

**1. Roughness.**—The roughness (small-scale asperities) of fracture surfaces is critical for evaluating shear strengths. Roughness descriptors such as striated or slickensided should be used whenever observed. For oriented core or outcrops, the orientation of striations or slickensides should be recorded. The rake of striations or slickensides should be recorded when observed in core from vertical drill holes which have not been oriented. In

## FIELD MANUAL



**Figure 5-3.—Examples of roughness and waviness of fracture surfaces, typical roughness profiles, and terminology. The length of each profile is in the range of 3 to 15 feet (1 to 5 m); the vertical and horizontal scales are equal.**

Coulomb's equation for shear strength ( $S = C + N \tan n$ ), the large scale undulations ( $i$ ) are entered into the equation as  $N \tan (n + i)$ .

**2. Waviness.**—Waviness (large-scale undulations) also should be recorded for fracture surveys along

## DISCONTINUITIES

Table 5-8.—Fracture roughness descriptors

Alpha-numeric descriptor	Descriptor	Criteria
R1	Stepped	Near-normal steps and ridges occur on the fracture surface.
R2	Rough	Large, angular asperities can be seen.
R3	Moderately rough	Asperities are clearly visible and fracture surface feels abrasive.
R4	Slightly rough	Small asperities on the fracture surface are visible and can be felt.
R5	Smooth	No asperities, smooth to the touch.
R6	Polished	Extremely smooth and shiny.

exposures. This is done by recording amplitude and wavelength, or as a minimum, describing as either planar or undulating.

**3. Weathering/alteration.**—Weathering or alteration of fracture surfaces is one of the criteria used for classifying rock mass weathering. Even though it is inherent in the weathering categories, the actual description of surface alteration and the associated loss of strength of the rock needs to be reported. Qualitative information can be presented when describing a particular joint set, joint, or fracture. The condition of the surface(s), such as depth of penetration and degree of staining or oxidation, should be recorded.

**Moisture Conditions.**—The presence of moisture or the potential for water flow along fractures may be an

## FIELD MANUAL

indicator of potential grout takes or seepage paths. Criteria and descriptors shown in table 5-9 describe moisture conditions for fractures. The presence or absence of moisture cannot be determined in core, but evidence of previous long-term water flow is found in leaching, color changes, oxidation, and dissolution.

Table 5-9.—Fracture moisture conditions descriptors

Alpha-numeric descriptor	Criteria
M1	The fracture is dry, tight, or filling (where present) is of sufficient density or composition to impede water flow. Water flow along the fracture does not appear possible.
M2	The fracture is dry with no evidence of previous water flow. Water flow appears possible.
M3	The fracture is dry but shows evidence of water flow such as staining, leaching, and vegetation.
M4	The fracture filling (where present) is damp, but no free water is present.
M5	The fracture shows seepage and is wet with occasional drops of water.
M6	The fracture emits a continuous flow (estimate flow rate) under low pressure. Filling materials (where present) may show signs of leaching or piping.
M7	The fracture emits a continuous flow (estimate flow rate) under moderate to high pressure. Water is squirting, and/or filling material (where present) may be substantially washed out.



## DISCONTINUITIES

### Field Index Tests

Schmidt Hammer tests can be used to estimate the hardness/strength of the rock surfaces along a discontinuity (which may be weaker than the body of the rock). The rebound of a spring-actuated projectile is measured from the surface being tested. The sample should be large enough, preferably intact or securely fastened to a stable base (i.e., concrete), so that it does not move during tests. Unclamped specimens should measure at least 0.7 foot (200 mm) in each direction. Direct testing on rock outcrops is usually the best method. Results should be obtained from both wet and dry surfaces. Ten readings are taken at various locations on each surface. The five lowest readings are discounted, and the five highest readings are averaged to obtain a realistic rebound number (Schmidt hardness). The hammer is always oriented perpendicular to the surface being tested. A unit dry weight must also be determined for the material being tested. Using the Schmidt hardness and the unit dry weight, the uniaxial compressive strength of the sample can be estimated.

Tilt-type sliding-friction tests are also useful in estimating the shear strength of fractures. Samples can be obtained from outcrops or rock core. A representative sample is tilted, and the angle at which the top of the sample slides relative to the bottom is measured. This angle is an approximation of the friction angle. Both wet and dry surfaces should be tested. The weight, thickness, and approximate dimensions of the sample parts also are recorded. A friction angle can be estimated in a similar manner using three pieces of core. Two representative pieces of core are used as a base, and the third piece is placed on top. The base is then tilted until the top piece of core slides, and this angle is measured.

## FIELD MANUAL

Pocket penetrometers may be used to estimate the strength of soil-like fillings or surfaces. The surface or a filling is penetrated by the penetrometer to the line on the penetrometer (about a quarter of an inch), and the approximate compressive strength is read directly from a calibrated scale on the penetrometer.

### **Example Descriptions of Fractures**

The examples which follow show a representative format for recording data. Actual descriptions vary and depend on whether the observations were recorded from exposures, drill core, or detailed joint surveys. Data report descriptions of discontinuities should be expanded to provide ranges and typical characteristics or additional significant data for each set or individual fractures from all observations.

**Drill Core.**—The following metric example is taken from a log of a rock core interval from a vertical drillhole; in an angle hole, orientation would be recorded as inclination from the core axis:

“. . . Moderately to slightly fractured (35% bedding joints, 65% joints). Core recovered in 210 to 730 mm lengths, mostly as 300 mm lengths. Bedding joints dip 30 to 35°, widely spaced (SP3) at 370 to 790 mm, avg 580 mm; 29 are tight, 6 are open; all are clean; 20 are moderately rough (R3), 15 are slightly rough (R4); oxidation penetrates 30 mm from surfaces (W4); all surfaces can be scratched by moderate knife pressure (H4). Joint set A dips 50 to 75°, mostly 60 to 65°, normal bedding; very widely spaced (SP2) at 0.9 to 1.2 m, avg 1 m; 3 are open, 1 is tight, and 9 are tight and healed by 3 to 30 mm thick, fresh (W1), very hard (H2), quartz-calcite fillings; the 3 open joints are clean, slightly rough (R4), oxidation stains penetrate

## DISCONTINUITIES

60 mm from surfaces (W4) which can be scratched by light to moderate knife pressure, all 3 show evidence of water flow (W6) . . . . ”

**Exposure Mapping.**—An example of fracture descriptions for an exposure, using English units, follows:

“Joint set A-1 strikes N. 20-38° W., mostly N. 20-25° W.; dips 50-65° NE, averages 54° NE. Very widely spaced (SP2), 3.8 to 7.3 ft apart, mostly 5 ft apart; most have moderately to highly continuous (C3 to C4) 25 to 55 ft trace lengths. Approx. 60% are open to moderately wide (O3 to O4), ranging in openness from 0.1 to 0.3 ft, remainder are tight to slightly open (O0 to O1). Approx. 10% of the joints contain thin, hard quartz fillings, 25% are clean, and 65% contain firm fat clay (CH) fillings which can be indented with thumbnail. All rock surfaces are moderately weathered with dendritic iron oxide staining which can be scratched with light to moderate knife pressure. Most surfaces are slightly rough (R4) and undulatory, approx. 20% are rough (R2) and planar. Undulations have wavelengths of 10 to 20 ft, average 15 ft, and amplitudes range from 0.2 to 0.5 ft. Clean joints are dry but show evidence of moisture flow (M3), most clay filled joints are damp but show no evidence of flow (M4).”

**Fracture Survey.**—Statistical evaluations are valuable, so it is important to collect joint properties for analysis. This can be readily accomplished using fracture survey techniques. Data sheets are prepared with appropriate columns for recording the data, a traverse distance and

## FIELD MANUAL

direction are established, and all pertinent data are measured and recorded. Data are analyzed using statistical methods. Refer to chapter 7 for detailed descriptions of discontinuity surveys.

### **Descriptions of Shears and Shear Zones**

Shear, fault, and associated terminology are defined at the beginning of this chapter. The following describes a method to classify shears, shear zones, and their associated features. A format to describe and quantify shear and fault physical characteristics and example descriptions is provided. For each discussion, the word "fault" can be substituted for "shear."

### **Identification or Naming of Shears**

Significant shears should be named for ease of identification in logs of exploration, mapping of exposures, interpretations on geologic drawings, discussion in reports, sample identification, and design treatment. Identification of a shear or shear zone by letter/number designation, such as S-9 (shear zone No. 9) or F-1 (fault zone No. 1), is recommended. Major splays may be identified by an appropriate combination of letters and numbers such as S-1a or F-2c. Shears also may be named by their location such as "powerplant shear," "Salt Creek Shear zone," or "left abutment fault" if only a few shears are present in the study area.

### **Uniform and Structured Shear Zones**

The identification and correlation of shears and shear zones from multiple but separate observations in boreholes, trenches, and limited outcrops are often difficult. The identification and description of shear and

## DISCONTINUITIES

shear zone components and their physical characteristics are necessary to both assist in correlating observations and for design analyses. Together with physical measurements of attitude and thickness, the description of the component parts and internal structure of a shear may be used for correlation in much the same way that geophysical signatures or lithology are used to identify certain stratigraphic units. The composition of a shear or shear zone at each exposure can be described as either uniform or structured. Illustrated in figure 5-4 is a 0.5-foot (150-mm) thick uniform shear composed of 40 percent breccia distributed relatively uniformly throughout 60 percent clay gouge. Although the shear contains two components, clay gouge and brecciated fragments, the components are distributed uniformly throughout the 0.5-foot shear zone.

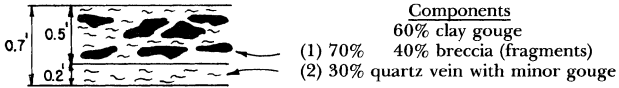


**Figure 5-4.—Uniform shear zone.**

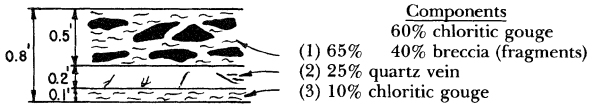
In contrast, a structured shear zone is composed of two or more zones which differ significantly in composition or physical properties. A structured shear zone could consist of components similar to the uniform shear described above with an additional 0.2-foot (60-mm) thick quartz vein along one contact, as shown on figure 5-5.

A more complex structured shear zone might have a 0.1-foot (30-mm) thick chloritic gouge layer adjacent to the vein as shown on figure 5-6.

## FIELD MANUAL

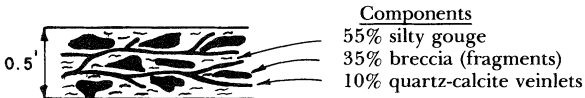


**Figure 5-5.—Structured shear zone  
(two zones or layers).**



**Figure 5-6.—Structured shear zone (three layers).**

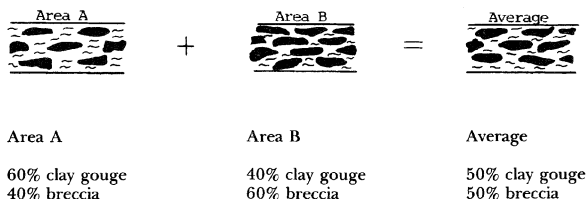
Numerous small quartz-calcite or other mineral veinlets commonly occur irregularly distributed throughout shears. The veinlets do not form distinct layers; therefore, they should be considered a percentage component of a uniform shear as illustrated on figure 5-7.



**Figure 5-7.—Uniform shear zone with veinlets.**

## DISCONTINUITIES

Shear zones may have minor or major lateral variations in the percentages of components within short distances at an exposure. The shear zone illustrated in figure 5-4 consists of 60 percent clay gouge and 40 percent rock fragments. Because the various components are not arranged in layers, the shear is of the uniform type. In an adjacent tunnel, the same shear zone may consist of 40 percent clay gouge and 60 percent rock fragments. If the exposure is limited, as in most tunnels or exploratory trenches, the percentages of the various components should be averaged, as illustrated on figure 5-8, and the average composition should be described.



**Figure 5-8.—Uniform shear zone (composite).**

### **Descriptors and Description Format for Shears and Shear Zones**

For shears to be uniformly and adequately described, a brief discussion of each applicable item in the following list should be included. The recommended format for describing a shear or shear zone, either uniform or structured as follows:

- Attitude
- Thickness

## FIELD MANUAL

- Composition

- Gouge

- Percent by volume

- Color

- Moisture content

- Consistency (hardness/strength)

- Composition

- Occurrence — layers or matrix

- Breccia

- Percent by volume

- Fragment size(s)

- Fragment shape(s)

- Fragment surface characteristics

- Lithology

- Hardness/strength

- Other components (vein or dike materials)

- Percentage

- Thickness

- Composition (mineralogy, texture, fracturing, etc.)

- Healing

- Zone strength

- Direction of movement (if determinable)

**Attitude.**—Measure strike and dip in exposures and from oriented core, report dip in vertical core, and measure angle from core axis for inclined drill core. Report an average figure if only moderate variations are observed. Provide both a range and average if large variations in orientation are apparent.

**Thickness.**—Report the true thickness of the shear or shear zone. True thickness can be measured directly or computed. Indicate an average figure for minor variations, as well as a range and average for significant



## DISCONTINUITIES

variations. Do not include associated features beyond the shear contacts (the shear-disturbed zone), or intact blocks of rock around which the shear has bifurcated as components of the thickness.

**Composition.**—Report an average percentage for each description-format component. The various layers or zones of structured shears may be indicated by use of bracketed numbers [i.e., shear 1(1), 1(2)]. Describe each individual layer or zone in the order it occurs as if each were a uniform shear.

### **1. Gouge.**—

- **Percentage.**—Report an average percent by volume for each exposure or layer.

- **Color.**—Report color to help distinguish between several types of gouge or to indicate alteration. The Munsel Color System can be used to record both the wet and dry color.

- **Moisture content.**—Describe the apparent moisture content upon initial exposure, using the following terms: wet (visible free water); moist (damp but without visible water); and dry (absence of moisture, dusty, dry to the touch).

- **Consistency (strength/hardness).**—Report the ease with which gouge can be worked by hand: Very soft [thumb penetrates gouge more than 1 in (25 mm) if the gouge occurs in a sufficient quantity]; soft [easily molded, penetration of thumb about 1 in (25 mm)]; firm [easily crumbled, can be penetrated by thumb up to 1/4 in : (5 mm)]; hard (can be broken with finger pressure, no indentation with thumb, readily indented with

## FIELD MANUAL

thumbnail); and very hard (cannot be indented with thumbnail). Use a pocket penetrometer to estimate gouge strength.

- **Composition.**—Report identifiable mineral types; talc, chlorite, mica. Otherwise, report the soil classification group name and/or symbol, such as CH, ML, lean clay, etc.

- **Occurrence.**—Describe how the gouge occurs, such as thin coatings on fragments, a matrix, or a layer.

### 2. *Breccia.*—

- **Percentage.**—Report an average percent by volume for each exposure or layer.

- **Fragment size.**—Estimate or measure the dimension of the most common fragment sizes and report as a range. Use fractions of an inch and tenths of a foot or metric equivalents.

- **Fragment shape.**—Unless the distribution of several shapes is nearly equal, report the most common shapes and degree of angularity as shown in figure 5-9.

- **Fragment characteristics.**—These should be included because they affect or provide an indication of the strength of the zone or help to identify a particular zone in several exposures or observations. Descriptions should include striated, slickensided, polished, rough, chloritic coatings, and weathering.

# DISCONTINUITIES

## Figure 5-9.—Standard descriptors and descriptive criteria for discontinuities.

### DISCONTINUITY TERMINOLOGY

**DISCONTINUITY** - A collective term used for all structural breaks in geologic materials which usually have zero or low tensile strengths. Discontinuities also may include discontinuities consisting of fractures (including joints), planes of weakness, cleavage, and cleavage/fault zones. Contacts between various units also may be considered discontinuities.

**FAULT** - A term used to describe any natural break in geologic material excluding shear and shear zones. Additional fracture terminology is provided below.

**SEAM** - A structural break where differential movement has taken place along a surface or zone of rupture by shearing, characterized by striations, slickensides, gouge, breccia, infillings, or any combination of these. Often direction, amount of displacement, and continuity may not be known because of limited exposures or observations.

**FRACTURE** - A shear with significant continuity which can be correlated between observations; occurs over a significant portion of a given site, foundation area, or roadway on its segment of a fault or fault zone defined in the literature. The displacement of a shear as a fault or fault zone is a site-specific designation.

**SHEAR/Fault ZONE** - A shear that is expressed by relative zones of shears. The zone may consist of gouge, breccia, or many related faults or shears together with fractured and crushed rock between the shears or fault, or any combination of these. In the literature, many fault zones simply are referred to as faults.

**SHEAR/Fault-DISTURBED ZONE** - An associated zone of fractures and/or folds adjacent to a shear of shear zone where the country rock has been subjected to only minor tectonic action and may be anisotropic. If adjacent to a fault or fault zone, the term is **FAULT-DISTURBED ZONE**. Anomalous deformation, and great extent of these phenomena depend upon depth of burial (pressure and temperature) during shearing, brittleness of materials, and the stress envelope.

### METHOD OF MEASURING DIP OF PLANAR DISCONTINUITIES, FOLIATION, AND BEDDING IN CORE

- Vertical hole - true dip is measured and reported.
- Angle hole - true dip usually not known, angle is measured from core axis and noted in notes.

### ROCK QUALITY DESIGNATION (RQD)

$RQD = \frac{\text{Sum of length of solid core pieces } \geq 0.125 \text{ ft (4 in.) long}}{\text{Length of the run (in feet)}} \times 100$

Expressed as percent (%)

### FRACTURE CONTINUITY

CONTINUITY DESCRIPTION	DISCONTINUITY LENGTH
<b>DISCONTINUITIES (D1)</b>	Less than 3 ft (1 m)
<b>SLIGHTLY CONTINUOUS (D2)</b>	3 to 20 ft (1 to 6 m)
<b>MODERATELY CONTINUOUS (D3)</b>	20 to 100 ft (6 to 30 m)
<b>HEAVILY CONTINUOUS (D4)</b>	2 to 100 ft (0.6 to 30 m)
<b>VERY CONTINUOUS (D5)</b>	Greater than 100 ft (30 m)

### FRACTURE ENDS (JOINT SURVEYS)

FRACTURE ENDS DESCRIPTION	DESCRIPTIVE CRITERIA
<b>E0</b>	Zero ends leave the exposure (both ends can be seen).
<b>E1</b>	One end of the fracture terminates in the exposure (one end can be seen).
<b>E2</b>	Two fracture ends do not terminate in the exposure (both ends cannot be seen).

### FRACTURE OPENNESS OR FILLING THICKNESS

FILLING THICKNESS DESCRIPTION	THICKNESS/OPENNESS	OPENNESS DESCRIPTION
<b>CLEAN (F0)</b>	No fill or coating	<b>VOID (F0)</b>
<b>VERY THIN (F1)</b>	Less than 0.002 ft (0.02 in.) (1 mm)	<b>SLIGHTLY OPEN (F1)</b>
<b>MODERATELY THIN (F2)</b>	0.002 to 0.01 ft (0.02 to 0.03 in.) (0.5 to 3 mm)	<b>MODERATELY OPEN (F2)</b>
<b>THIN (F3)</b>	0.01 to 0.03 ft (1/8 to 3/8 in.) (3 to 10 mm)	<b>OPEN (F3)</b>
<b>MODERATELY THICK (F4)</b>	0.03 ft (0.9 in.) to 0.1 ft (3 to 30 mm)	<b>MODERATELY WIDE (F4)</b>
<b>THICK (F5)</b>	Greater than 0.1 ft (30 mm) actual thickness or openings recorded	<b>WIDE (F5)</b>

### FRACTURE SURFACE AND / OR FILLING ALTERATION AND HARDNESS

Descriptors for weathering or alteration of fracture surfaces and fracture fillings (excluding wall materials) are the same as those used for weathering and alteration of rock.

Descriptors for hardness/strength of fillings and/or fracture surfaces are the same as those presented for hardness of rock or consistency of soils.

### DISCONTINUITY HEALING

**TOTALLY HEALED (H1)** - All fragments bonded, discontinuity is completely healed or reconstructed to a degree at least as hard as surrounding rock.

**MODERATELY HEALED (H2)** - Greater than 50 percent of fractured or sheared material, discontinuity surface or filling is healed or reconstructed.

**PARTIALLY HEALED (H3)** - Less than 50 percent of fractured or sheared material, discontinuity surface or filling is healed or reconstructed.

**NOT HEALED (H4)** - Discontinuity surface, fracture zone, sheared material, or filling is not healed or reconstructed, rock fragments or filling (if present) held in place by their own irregularity and/or cohesiveness.

### SHEAR / FAULT DESCRIPTORS

#### SHEAR / FAULT GOUGE CONSISTENCY

DESCRIPTION	DESCRIPTIVE CRITERIA (Size/or to consistency of soils)
<b>VERY HARD</b>	Gouge cannot be broken with finger pressure; cannot be indented with fingernail.
<b>HARD</b>	Gouge can be broken with firm finger pressure; can be indented with fingernail; cannot be indented with thumb.
<b>FIRM</b>	Gouge can be easily crumbled; can be indented with thumb 1 to 5 mm.
<b>SOFT</b>	Gouge can be easily melted; can be penetrated with thumb 5 to 25 mm.
<b>VERY SOFT</b>	Gouge can be penetrated with thumb more than 25 mm.

#### SHEAR / FAULT MOISTURE CONDITIONS

The apparent relative content of gouge is described as **WET** (visible free water), **MOIST** (dark but no visible water), and **DRY** (absence of moisture, glossy, dry to the touch). Moisture descriptors (M) through M5 may be used to describe the shear or shear zone.

### FRACTURE TERMINOLOGY

EXAMPLES SHOWN FOR CORE, BUT APPLICABLE TO ANY OBSERVATION

**JOINT (J1)** - A relatively planar fracture along which there has been little or no shearing displacement.

**POLIATION JOINT (PJ2) OR BEDDING JOINT (BJ2)** - A relatively planar fracture which is parallel to foliation or bedding along which there has been little or no shearing displacement.

**BEDDING PLANE SEPARATION** - A separation along bedding after extraction or exposure to stress related or slaking.

**INCIPENT JOINT (IJ3) OR UNCOMPLETE FRACTURE (UF3)** - A joint or fracture which does not continue through the specimen or at least not seen with the naked eye. However, when the specimen is wetted and then allowed to dry, the joint or fracture trace is evident. When core is broken, it breaks along an existing plane.

**MINOR FRACTURE (MF4)** - A natural break (fracture) with a generally rough, very irregular, nonplanar surface which would not be noted in a joint run.

**MECHANICAL BREAK (MB5)** - A break due to drilling, blasting, or handling. Mechanical breaks parallel to bedding or foliation are called **Bedding Breaks (MB)** or **Foliation Breaks (FB)**, respectively. Bedding mechanically breaks may be difficult. The absence of oxidation, staining, or mineral fillings, and often a lustrous or irregular surface are clues for recognition.

**FRACTURE ZONE (FZ6)** - Numerous very closely spaced intersecting fractures. Often fractured core cannot be fitted together.

### FRACTURE FREQUENCY

**FRACTURE FREQUENCY** - The number of natural fractures occurring within a base length or core run. The number of fractures is divided by the length and is reported as fractures per foot or fractures per meter. Expressed as 1/m or 1/m.

### FRACTURE DENSITY

**FRACTURE DENSITY** - Based on the spacing of all natural fractures in an exposure or core recovery lengths in boreholes; **EXCLUDES MECHANICAL BREAKS, SHEARS, AND OTHER ZONES**. However, shear-discontinuity zones (FOLIATION AND BEDDING PLANE SEPARATION) are included. Descriptors for fracture density apply to all rock exposures and are based on core lengths, outcrops, or foundation cut slopes and overburden, as well as boreholes. Descriptive criteria presented below are based on borehole cores where lengths are measured along the core axis, for other exposures the criteria is distance measured between fractures (size of blocks).

**UNFRACTURED (FR0)** - No fractures.

**VERY SLIGHTLY FRACTURED (FR1)** - Core recovered mostly in lengths greater than 3 feet (1 m).

**SLIGHTLY TO VERY SLIGHTLY FRACTURED (FR2)\***

**SLIGHTLY FRACTURED (FR3)** - Core recovered mostly in lengths from 1 to 3 feet (30 to 100 cm) with few scattered lengths less than 1 foot (30 cm) or greater than 3 feet (100 cm).

**MODERATELY TO SLIGHTLY FRACTURED (FR4)\***

**MODERATELY FRACTURED (FR5)** - Core recovered mostly in 0.3- to 3.0-foot (100- to 300-mm) lengths with most lengths about 0.5 to 1 foot (100 mm).

**INTENSELY TO MODERATELY FRACTURED (FR6)\***

**INTENSELY FRACTURED (FR7)** - Lengths average from 0.1 to 0.3 foot (30 to 100 mm) with scattered programmed intervals. Core recovered mostly in lengths less than 0.5 foot (100 mm).

**VERY INTENSELY TO INTENSELY FRACTURED (FR8)\***

**VERY INTENSELY FRACTURED (FR9)** - Core recovered mostly as chips and fragments with a few scattered short core lengths.

\* Combination of fracture densities (e.g., Very Intensely to Intensely Fractured) or Moderately to Slightly Fractured are used where equal distribution of both fracture density characteristics are present over a significant interval or exposure, or where characteristics are "in between" the descriptor definitions.

### FRACTURE MOISTURE CONDITIONS

MOISTURE DESCRIPTION	DESCRIPTIVE CRITERIA
<b>M1</b>	The fracture is dry. It is tight or filling (where present) to of sufficient density or composition to trap water. Water flow along the fracture does not appear possible.
<b>M2</b>	The fracture is dry with no evidence of previous water flow. Water flow appears possible.
<b>M3</b>	The fracture is dry but shows evidence of water flow such as staining, leaching, and/or vegetation.
<b>M4</b>	The fracture or filling (where present) is damp, but no free water is present.
<b>M5</b>	The fracture shows seepage. It is wet with occasional drops of water.
<b>M6</b>	The fracture emits a continuous flow (estimate flow rate) under low pressure. Filling materials (where present) may show signs of leaching or pitting.
<b>M7</b>	The fracture emits a continuous flow (estimate flow rate) under moderate to high pressure. Water is seeping and/or filling material (where present) may be substantially washed out.

### FRACTURE ROUGHNESS

Refers to small scale asperities of surfaces, not large scale undulations or wrinkles.

**SMOOTH (RS1)** - Near-normal steps and ridges occur on the fracture surface.

**ROUGH (RS2)** - Large, angular asperities can be seen.

**MODERATELY ROUGH (RS3)** - Asperities are clearly visible and fracture surface feels abrasive.

**MODERATELY SMOOTH (RS4)** - Small asperities on the fracture surface are visible and can be felt.

**SMOOTH (RS5)** - No asperities, smooth to the touch.

**POLISHED (RS6)** - Extremely smooth and shiny.

ALWAYS THINK SAFETY

UNITED STATES  
DEPARTMENT OF THE INTERIOR  
BUREAU OF RECLAMATION

**GEOLOGY FOR DESIGNS & SPECIFICATIONS  
STANDARD DESCRIPTORS AND DESCRIPTIVE  
CRITERIA FOR DISCONTINUITIES**

GEOLOGY FOR DESIGNS AND SPECIFICATIONS - TECHNICAL MANUAL  
DESIGNED BY: JAMES W. BROWN, JR., GARY L. HANCOCK, JAMES W. BROWN, JR., GARY L. HANCOCK, JAMES W. BROWN, JR., GARY L. HANCOCK  
DRAWN BY: JAMES W. BROWN, JR., GARY L. HANCOCK, JAMES W. BROWN, JR., GARY L. HANCOCK, JAMES W. BROWN, JR., GARY L. HANCOCK  
CHECKED BY: JAMES W. BROWN, JR., GARY L. HANCOCK, JAMES W. BROWN, JR., GARY L. HANCOCK, JAMES W. BROWN, JR., GARY L. HANCOCK  
DATE: OCTOBER 1, 1991

**40-D-6499**

## FIELD MANUAL

## DISCONTINUITIES

- **Lithology.**—The identification of rock fragments (rock type) is essential, particularly if different from the surrounding rock mass or if several rock types are present in the zone. Indicate if fragments within the zone are altered.

- **Fragment hardness/strength.**—Describe how the average-size fragment can be broken across its least dimension using the following format: can be broken with (light, moderate, heavy) manual pressure or hammer blow.

**3. Other components (vein or dike material).**—Describe any large veins or dikes which occur within the shear, either as a component of a uniform shear zone, usually occurring in the form of branching, discontinuous veinlets less than 1/2-inch (13-mm) thick, or as a layer (zone) within a structured shear. Dikes or large veins should be included as a single layer of a shear zone if they are bounded by shears. Also, they should be described as a rock unit. If a shear occurs only along one border of a dike or vein, the dike or vein should be described only as a rock unit.

- **Percentage.**—Report as an average percent by volume for the exposure or layer.

- **Thickness.**—Report as an average or range of thickness.

- **Composition.**—Provide a brief description of mineralogy and texture (e.g., leached, vuggy). Fracture density may be reported here if significant.

## FIELD MANUAL

**Healing.**—Small veinlets which are components of a uniform shear zone and which actually form a bond between fragments tend to increase the strength of the shear zone (see following section). Healing should be determined by attempting to separate fragments manually or using a rock or pick. If fragments are bonded by some healing or cementing agent, the shear zone is described as partly healed (less than 50 percent of fragments bonded), mostly healed (more than 50 percent of fragments bonded), and totally healed (all fragments bonded by vein material).

**Zone Strength.**—When possible, the strength of the entire shear zone exposed in outcrops, tunnels, and exploratory trenches should be reported by the ease of which the sheared material can be dug from the exposure. The following guide is to be used: can be dug from wall, floor, or outcrop with light, moderate, or heavy finger pressure or hammer blow. Strength should be reported for each significant layer of a shear zone.

**Direction of Movement.**—If determinable, the amount, direction, and type of displacement are reported. Type and direction of displacement (dip-slip, strike-slip, oblique-slip, normal, reverse, right-lateral) may be directly observable as shown by drag, tension fractures, striations, offset "marker units" (such as beds, dikes, veins, or other structural units). The amount of both horizontal and vertical separation and, if possible, a net-slip solution should be included. Regional stress fields may be used to postulate displacement in the absence of site observations.

## DISCONTINUITIES

### Example Descriptions for Shears and Shear Zones

The following are example descriptions for both a uniform and a structured shear zone; actual descriptions may depend on the type of observation.

A description, using metric units, of a uniform shear in an angle hole could be:

“21.30 to 22.31: Shear. 210 mm thick, upper contact inclined  $40^\circ$ , lower contact inclined  $61^\circ$  from core axis, averages  $51^\circ$ , parallel to bedding. Composed of approx. 15%, blackish-green, moist, soft, chloritic clay and 85% 2 to 10 mm thick platy and lens-shaped, subrounded, polished, intensely weathered (W7) metasandstone fragments. Fragments break with light hand pressure. Fragments partly healed by 1 mm thick quartz-calcite veinlets.”

A structured shear zone in a vertical drill hole core could be reported in English units as:

“118.6 to 121.9': Shear zone. 2.3 ft thick, upper and lower contacts dip  $40$  to  $45^\circ$ , subparallel to foliation. Zone 1, upper 0.3 ft; consists of 45% green, moist, soft, chloritic clay gouge and 55% 0.05 to 0.1 ft subrounded, blocky, polished, fresh dike fragments; fragments break with moderate hammer blow. Zone 2 is 1.1 ft thick; consists of very intensely fractured, fresh dike which is partly healed by 0.01 to 0.3 ft-thick calcite veinlets and a 0.1 ft-thick, vuggy quartz-calcite vein at base of dike. Zone 3 is 0.5 ft of No Recovery. Zone 4, the lower 0.3 ft; consists of 70% gray, moist, firm, silty gouge, and 15% 0.01 to 0.03 ft-thick, wedge-shaped, fresh, striated

## FIELD MANUAL

horn-blende schist fragments, and 15% 0.02 ft-thick, angular, blocky, fresh quartz fragments. Fragments break with light hammer blow.”

### **Description of Shear-Disturbed Zones**

Fractures, fracture zones, drag zones, mineralized bedrock, and dikes or large veins along which one contact is sheared but are not themselves sheared or enclosed within a zone, are not included in the thickness of a shear or shear zone. The associated zone should be identified to adequately describe geologic conditions of engineering significance. For example, the shear-disturbed zone and an adjacent dike might be described as:

“ . . . The shear is bounded by a 1.5- to 4-ft wide shear-disturbed zone of very intensely to intensely fractured chloritized dike (FD8). This zone averages 3 ft wide along the upper contact and 2 ft wide in the associated chloritized dike adjacent to the lower contact. Hydrothermal alteration consisting of epidote, chlorite, pyrite, and quartz extends irregularly outward 2 to 7 ft normal to the shear boundaries.”

### **BIBLIOGRAPHY**

- [1] *International Journal of Rock Mechanics Mining Science and Geomechanics Abstracts*, v. 15, pp. 319-368, 1978.
- [2] *The Glossary of Geology*, 4th edition, American Geologic Institute, Alexandria, Virginia, 1997.
- [3] Deere, D.U., and D.W. Deere, “RQD After Twenty Years,” U.S. Army Corps of Engineers, 1989.



## DISCONTINUITIES

- [4] Davis, George H., *Structural Geology of Rocks and Regions*, John Wiley & Sons, 1984.
- [5] *Earth Manual*, Part II, Third Edition, Bureau of Reclamation, U.S. Department of the Interior, 1990.



## **Chapter 6**

# **GEOLOGIC MAPPING AND DOCUMENTATION**

Geologic mapping is defined as the examination of natural and manmade exposures of rock or unconsolidated materials, the systematic recording of geologic data from these exposures, and the analysis and interpretation of these data in two- or three-dimensional format (maps, cross sections, and perspective [block] diagrams). The maps and cross sections generated from these data: (1) serve as a record of the location of factual data; (2) present a graphic picture of the conceptual model of the study area based on the available factual data; and (3) serve as tools for solving three-dimensional problems related to the design, construction, and/or maintenance of engineered structures or site characterization. This chapter presents guidelines for the collection and documentation of surface and subsurface geologic field data for use in the design, specifications, construction, or maintenance of engineered structures and site characterization studies.

### **Responsibilities of the Engineering Geologist**

An engineering geologist defines, evaluates, and documents site-specific geologic conditions relating to the design, construction, maintenance, and remediation of engineered structures or other sites. This responsibility also may include more regionally based geologic studies, such as materials investigations or regional reconnaissance mapping. An engineering geologist engaged in geologic mapping is responsible for:

- Recognizing the key geologic conditions in a study area that will or could significantly affect hazardous and toxic waste sites or a proposed or existing structure;

## FIELD MANUAL

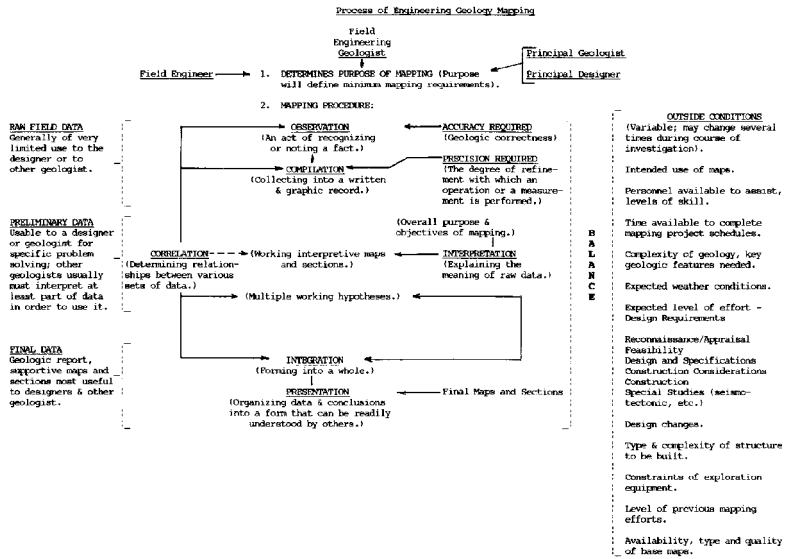
- Integrating all the available, pertinent geologic data into a rational, interpretive, three-dimensional conceptual model of the study area and presenting this conceptual model to design and construction engineers, other geologists, hydrologists, site managers, and contractors in a form that can be understood.

The process and responsibilities of engineering geology mapping are illustrated in figure 6-1.

The engineering geologist needs to realize that geologic mapping for site characterization is a dynamic process of gathering, evaluating, and revising geologic data and that the significance of these data, both to the structure and to further exploration, must be continually assessed. The initial exploration program for a structure is always based on incomplete data and must be modified continuously as the site geology becomes better understood. The key to understanding the site geology is through interpretive geologic drawings such as geologic maps, cross sections, isopachs, and contour maps of surfaces. These working drawings, periodically revised and re-interpreted as new data become available, are continuously used to assess the effects of the site geology and to delineate areas where additional exploration is needed. These drawings are used in designs, specifications, and modeling and maintained in the technical record of the project.

### **Development of a Study Plan**

Prior to mapping any project, a study plan must be developed. Depending on the complexity of the site geology, the nature of the engineered structure, and the level of



**Figure 6-1.—Process of engineering geology mapping.**

## FIELD MANUAL

previous studies, the study plan may be preliminary or comprehensive. Although elements of the plan may be modified, expanded, or deleted as geologic data become available, the primary purpose of the study plan—coordination among all geologists and engineers working on the project—should be retained. Early study plan development and agreement to this plan by those involved in the project are necessary to prevent the collection of unneeded, possibly costly data and ensure needed data are available at the correct time in the analysis, design, and construction process.

### **Scope of Study**

The purpose and scope of the mapping project are strongly influenced by the primary engineering and geologic considerations, the level of previous studies, and overall job schedules. The purpose and scope are formulated jointly by the geologists and engineers on the project. Time of year and critical dates for needed information also will have a great impact on the pace of data collection and the personnel needed to handle a mapping project. Discussion of these factors prior to initiating the mapping program is essential so that only necessary data are obtained and the work can be completed on schedule. Items to consider when defining the scope of a mapping program are:

- 1. Study limits.**—Set general regional and site study limits based on engineering and geologic needs.
- 2. Critical features and properties.**—Determine the critical geologic features and physical properties of site materials that will need to be defined and discuss the difficulties in collecting data on these features.

## MAPPING

**3. Schedules.**—Determine schedules under which the work will be performed and define key data due dates. Prioritize work to be done. The time of year the mapping is to be performed, the type of mapping required, available personnel and their skills, the availability of support personnel such as drill crews and surveyors, and budget constraints will influence the work schedule and must be carefully evaluated.

**4. Extent of previous studies.**—Collect and study all available geologic literature for the study area. The extent and adequacy of previous studies helps to define the types of mapping required and how data will be collected, i.e., based on analyses, design, or construction needs.

**5. Photography.**—Aerial and terrestrial photography should be considered for any project. As a minimum, aerial photographs of the site should be reviewed. Aerial photographs reveal features that are difficult to recognize from the ground or at small scales. Extensive use of terrestrial or aerial photography will require a different approach to the mapping program. Define areas where terrestrial photogrammetry could aid mapping progress. Terrestrial photography of various types is an integral part of the final study record.

### Specific Mapping Requirements

This section provides the basic considerations an engineering geologist should evaluate prior to starting any mapping project or portion of a mapping project.

#### Map Type

Define the types of mapping required and how data are to be collected, including special equipment needed for

## FIELD MANUAL

data collection. The types of mapping required depend on the study purpose or the type of structure or site that is to be built or rehabilitated, structure size, the phase of study (planning through operation and maintenance), and the specific design needs.

### **Scales and Controls**

Define the required scales for design or construction needs. Although finished maps can be enlarged or reduced photographically or by Computer-Aided Drafting Design (CADD)-generated drawings to any desired scale, in most cases map text and symbols will have to be redone for legibility. Selection of an adequate map scale at the beginning of a mapping project will save time and energy as well as help ensure that the types of data needed can be portrayed adequately on the final drawings. Suggested map scales for various types of investigations are listed under specific mapping techniques.

The horizontal and vertical accuracy and precision of locations on a map depend on the spatial control of the base map. General base map controls are listed in decreasing significance: (1) Survey Control or Controlled Terrestrial Photogrammetry—geology mapped from survey controlled observation points or by plane table or stadia; (2) Existing Topographic Maps—control for these maps vary with scale. The most accurate are large-scale photogrammetric topographic maps generated from aerial photographs for specific site studies; (3) **U n c o n t r o l l e d   A e r i a l / T e r r e s t r i a l** Photogrammetry—Camera lens distortion is the chief source of error; (4) Brunton Compass/Tape Surveys—can be reasonably accurate if measurements are taken with care; and (5) Sketch Mapping—Practice is needed to make reasonably accurate sketch



## MAPPING

maps. The Global Positioning System can provide adequate position locations depending on the required accuracy or precision.

### **Global Positioning System**

The Global Positioning System (GPS) is a system of satellites that provides positioning data to receivers on earth. The receiver uses the positioning data to calculate the location of the receiver on earth. Accuracy and type of data output depends on many factors that must be evaluated before using the system. The factors that must be evaluated are: (1) the needs of the project, (2) the capabilities of the GPS equipment, and (3) the parameters necessary for collecting the data in an appropriate form.

#### **Project Requirements**

The location accuracy or precision needed by the project is a controlling factor whether GPS is appropriate for the project. The actual needs of the project should be determined, being careful to differentiate with “what would be nice.” Costs should be compared between traditional surveying and GPS.

#### **GPS Equipment**

Different GPS receiver/systems have different accuracies. Accuracies can range from 300 ft to inches (100 m to cm) depending on the GPS system. Costs increase exponentially with the increase in accuracy. A realistic evaluation of the typical accuracy of the equipment to be used is necessary, and a realistic evaluation of the needed, not “what would be nice,” accuracy is important. Possible accuracy and typical accuracy are often not the same.

## FIELD MANUAL

### **Datums**

The datum or theoretical reference surface to be used for the project must be determined at the start. U.S. Geological Survey (USGS) topographic maps commonly use North American Datum (NAD) 27, but most new surveys use NAD 83. Changing from one datum to another can result in apparent location differences of several hundred feet or meters if not done properly.

### **Map Projections**

The map projection is the projection used to depict the round shape of the earth on a flat plane or map. The most common projections used in the United States are the Transverse Mercator and the Lambert Conformal Conic. State plane coordinate systems almost exclusively use one or the other. To use these state plane projections, location and definition parameters are necessary. Table 6-1 has the types of projections and the projection parameters for each state in the United States. A discussion of map projections and coordinate systems is in *Map Projections - A Working Manual*, USGS Professional Paper 1395[1].

**Transverse Mercator.**—The Transverse Mercator projection requires a central meridian, scale reduction, and origin for each state or state zone.

**Lambert Conformal Conic.**—The Lambert Conformal Conic projection requires two standard parallels and an origin for each state or state zone.

**Coordinate System.**—The coordinate system is the grid system that is to be used on the project. The state plane

## MAPPING

Table 6-1.—U.S. State plane coordinate systems – 1927 datum  
(T indicates Transverse Mercator; L. Lambert Conformal Conic;  
H. Hotine Oblique Mercator. Modified slightly and updated from  
Mitchell and Simmons, 1945, p. 45-47)

Area	Projec- tion	Zones	Area	Projec- tion	Zones
Alabama _____	T	2	Nevada _____	T	3
Alaska _____	T	8	New Hampshire __	T	1
	L	1	New Jersey ___	T	1
	H	1	New Mexico ___	T	3
Arizona _____	T	3	New York _____	T	3
Arkansas _____	L	2	North Carolina	L	1
California _____	L	7	North Dakota _	L	2
Colorado _____	L	3	Ohio _____	L	2
Connecticut _____	L	1	Oklahoma _____	L	2
Delaware _____	T	1	Oregon _____	L	2
Florida _____	T	2	Pennsylvania _	L	2
	L	1	Puerto Rico & Virgin Islands _____	L	2
Georgia _____	T	2	Rhode Island __	T	1
Hawaii _____	T	5	Samoa _____	L	1
Idaho _____	T	3	South Carolina _____	L	2
Illinois _____	T	2	South Dakota _	L	2
Indiana _____	T	2	Tennessee _____	L	1
Iowa _____	L	2	Texas _____	L	5
Kansas _____	L	2	Utah _____	L	3
Kentucky _____	L	2	Vermont _____	T	1
Louisiana _____	L	3	Virginia _____	L	2
Maine _____	T	2	Washington ___	L	2
Maryland _____	L	1	West Virginia _	L	2
Massachusetts _	L	2	Wisconsin _____	L	3
Michigan <sup>1</sup>			Wyoming _____	T	4
obsolete _____	T	3			
current _____	L	3			
Minnesota _____	L	3			
Mississippi _____	T	2			
Missouri _____	T	3			
Montana _____	L	3			
Nebraska _____	L	2			

# FIELD MANUAL

Table 6-1.—U.S. State plane coordinate systems – 1927 datum  
(continued)

<b>Transverse Mercator Projection</b>			
<b>Zone</b>	<b>Central meridian</b>	<b>Scale reduction<sup>2</sup></b>	<b>Origin<sup>3</sup> (latitude)</b>
<b>Alabama</b>			
East _____	85° 50' W.	1:25,000	30° 30' N.
West _____	87 30	1:15,000	30 00
<b>Alaska<sup>4</sup></b>			
2 _____	142 00	1:10,000	54 00
3 _____	146 00	1:10,000	54 00
4 _____	150 00	1:10,000	54 00
5 _____	154 00	1:10,000	54 00
6 _____	158 00	1:10,000	54 00
7 _____	162 00	1:10,000	54 00
8 _____	166 00	1:10,000	54 00
9 _____	170 00	1:10,000	54 00
<b>Arizona</b>			
East _____	110 10	1:10,000	31 00
Central _____	111 55	1:10,000	31 00
West _____	113 45	1:15,000	31 00
Delaware _____	75 25	1:200,000	38 00
<b>Florida<sup>4</sup></b>			
East _____	81 00	1:17,000	24 20
West _____	82 00	1:17,000	24 20
<b>Georgia</b>			
East _____	82 10	1:10,000	30 00
West _____	84 10	1:10,000	30 00
<b>Hawaii</b>			
1 _____	155 30	1:30,000	18 50
2 _____	156 40	1:30,000	20 20
3 _____	158 00	1:100,000	21 10
4 _____	159 30	1:100,000	21 50
5 _____	160 10	0	21 40
<b>Idaho</b>			
East _____	112 10	1:19,000	41 40
Central _____	114 00	1:19,000	41 40
West _____	115 45	1:15,000	41 40
<b>Illinois</b>			
East _____	88 20	1:40,000	36 40
West _____	90 10	1:17,000	36 40
<b>Indiana</b>			
East _____	85 40	1:30,000	37 30
West _____	87 05	1:30,000	37 30

## MAPPING

Table 6-1.—U.S. State plane coordinate systems – 1927 datum  
(continued)

<b>Transverse Mercator Projection</b>			
<b>Zone</b>	<b>Central meridian</b>	<b>Scale reduction<sup>2</sup></b>	<b>Origin<sup>3</sup> (latitude)</b>
Maine			
East _____	68° 30' W.	1:10,000	43° 50' N.
West _____	70 10	1:30,000	42 50
Michigan (old) <sup>4</sup>			
East _____	83 40	1:17,500	41 30
Central _____	85 45	1:11,000	41 30
West _____	88 45	1:11,000	41 30
Mississippi			
East _____	88 50	1:25,000	29 40
West _____	90 20	1:17,000	30 30
Missouri			
East _____	90 30	1:15,000	35 50
Central _____	92 30	1:15,000	35 50
West _____	94 30	1:17,000	36 10
Nevada			
East _____	115 35	1:10,000	34 45
Central _____	116 40	1:10,000	34 45
West _____	118 35	1:10,000	34 45
New Hampshire _____	71 40	1:30,000	42 30
New Jersey _____	74 40	1:40,000	38 50
New Mexico			
East _____	104 20	1:11,000	31 00
Central _____	106 15	1:10,000	31 00
West _____	107 50	1:12,000	31 00
New York <sup>4</sup>			
East _____	74 20	1:30,000	40 00
Central _____	76 35	1:16,000	40 00
West _____	78 35	1:16,000	40 00
Rhode Island _____	71 30	1:160,000	41 05
Vermont _____	72 30	1:28,000	42 30
Wyoming			
East _____	105 10	1:17,000	40 40
East Central	107 20	1:17,000	40 40
West Central	108 45	1:17,000	40 40
West _____	110 05	1:17,000	40 40

# FIELD MANUAL

Table 6-1.—U.S. State plane coordinate systems – 1927 datum  
(continued)

<b>Lambert Conformal Conic projection</b>				
<b>Zone</b>	<b>Standard parallels</b>		<b>Origin<sup>5</sup></b>	
			<b>Longitude</b>	<b>Latitude</b>
Alaska <sup>4</sup>				
10 _____	51° 50' N.	53° 50' N.	176° 00' W. <sup>5a</sup>	51° 00' N.
Arkansas				
North _____	34 56	36 14	92 00	34 20
South _____	33 18	34 46	92 00	32 40
California				
I _____	40 00	41 40	122 00	39 20
II _____	38 20	39 50	122 00	37 40
III _____	37 04	38 26	120 30	36 30
IV _____	36 00	37 15	119 00	35 20
V _____	34 02	35 28	118 00	33 30
VI _____	32 47	33 53	116 15	32 10
VII _____	33 52	34 25	118 20	34 08 <sup>5b</sup>
Colorado				
North _____	39 43	40 47	105 30	39 20
Central _____	38 27	39 45	105 30	37 50
South _____	37 14	38 26	105 30	36 40
Connecticut _____	41 12	41 52	72 45	40 50 <sup>5d</sup>
Florida <sup>4</sup>				
North _____	29 35	30 45	84 30	29 00
Iowa				
North _____	42 04	43 16	93 30	41 30
South _____	40 37	41 47	93 30	40 00
Kansas				
North _____	38 43	39 47	98 00	38 20
South _____	37 16	38 34	98 30	36 40
Kentucky				
North _____	37 58	38 58	84 15	37 30
South _____	36 44	37 56	85 45	36 20
Louisiana				
North _____	31 10	32 40	92 30	30 40
South _____	29 18	30 42	91 20	28 40
Offshore _____	26 10	27 50	91 20	25 40
Maryland _____	38 18	39 27	77 00	37 50 <sup>5c</sup>
Massachusetts				
Mainland _____	41 43	42 41	71 30	41 00 <sup>5d</sup>
Island _____	41 17	41 29	70 30	41 00 <sup>5c</sup>

# MAPPING

Table 6-1.—U.S. State plane coordinate systems – 1927 datum  
(continued)

<b>Lambert Conformal Conic projection (continued)</b>				
<b>Zone</b>	<b>Standard parallels</b>		<b>Origin<sup>5</sup></b>	
			<b>Longitude</b>	<b>Latitude</b>
Michigan				
(current) <sup>4</sup>				
North _____	45° 29' N.	47° 05' N.	87° 00' W.	44° 47' N.
Central _____	44 11	45 42	84 20	43 19
South _____	42 06	43 40	84 20	41 30
Minnesota				
North _____	47 02	48 38	93 06	46 30
Central _____	45 37	47 03	94 15	45 00
South _____	43 47	45 13	94 00	43 00
Montana				
North _____	47 51	48 43	109 30	47 00
Central _____	46 27	47 53	109 30	45 50
South _____	44 52	46 24	109 30	44 00
Nebraska				
North _____	41 51	42 49	100 00	41 20
South _____	40 17	41 43	99 30	39 40
New York <sup>4</sup>				
Long Island __	40 40	41 02	74 00	40 30 <sup>5f</sup>
North Carolina _____				
Carolina _____	34 20	36 10	79 00	33 45
North Dakota _____				
North _____	47 26	48 44	100 30	47 00
South _____	46 11	47 29	100 30	45 40
Ohio _____				
North _____	40 26	41 42	82 30	39 40
South _____	38 44	40 02	82 30	38 00
Oklahoma _____				
North _____	35 34	36 46	98 00	35 00
South _____	33 56	35 14	98 00	33 20
Oregon _____				
North _____	44 20	46 00	120 30	43 40
South _____	42 20	44 00	120 30	41 40
Pennsylvania _____				
North _____	40 53	41 57	77 45	40 10
South _____	39 56	40 58	77 45	39 20
Puerto Rico and Virgin Islands				
1 _____	18° 02' N.	18° 26' N.	66° 26' W.	17° 50' N. <sup>5g</sup>
2 (St. Croix) __	18 02	18 26	66 26	17 50 <sup>5f, g</sup>

## FIELD MANUAL

Table 6-1.—U.S. State plane coordinate systems – 1927 datum  
(continued)

<b>Lambert Conformal Conic projection (continued)</b>				
<b>Zone</b>	<b>Standard parallels</b>		<b>Origin<sup>5</sup></b>	
			<b>Longitude</b>	<b>Latitude</b>
Samoa _____	14° 16' S.	(single)	170 00 <sup>5h</sup>	— —
South Carolina				
North _____	33° 46' N.	34 58	81 00	33 00
South _____	32 20	33 40	81 00	31 50
South Dakota				
North _____	44 25	45 41	100 00	43 50
South _____	42 50	44 24	100 20	42 20
Tennessee _____	35 15	36 25	86 00	34 40 <sup>5f</sup>

Note: All these systems are based on the Clarke 1866 ellipsoid and are based on the 1927 datum. Origin refers to rectangular coordinates.

<sup>1</sup> The major and minor axes of the ellipsoid are taken at exactly 1.0000382 times those of the Clarke 1866, for Michigan only. This incorporates an average elevation throughout the State of about 800 ft, with limited variation.

<sup>2</sup> Along the central meridian.

<sup>3</sup> At origin, x = 500,000 ft, y = 0 ft, except for Alaska zone 7, x = 700,000 ft; Alaska zone 9, x = 600,000 ft; and New Jersey, x = 2,000,000 ft.

<sup>4</sup> Additional zones listed in this table under other projection(s).

<sup>5</sup> At origin, x = 2,000,000 ft, y = 0 ft, except (a) x = 3,000,000 ft, (b) x = 4,186,692.58, y = 4,160,926.74 ft, (c) x = 800,000 ft, (d) x = 600,000 ft, (e) x = 200,000 ft, (f) y = 100,000 ft, (g) x = 500,000 ft, (h) x = 500,000 ft, y = 0, but radius to latitude of origin = -82,000,000 ft.

system is used by most projects, but latitude/longitude, universal transverse mercator, or a local coordinate system may be used.

**State Plane Coordinate Systems—changes for 1983 datum.**—This listing indicates changes for the NAD 1983 datum from projections, parameters, and origins of zones for the NAD 1927 datum. State plane coordinates based on the 1927 datum *cannot* be correctly converted to coordinates on the 1983 datum merely by using inverse formulas to convert from 1927 rectangular coordinates to latitude and longitude, and then using



## MAPPING

forward formulas with this latitude and longitude to convert to 1983 rectangular coordinates. Due to readjustment of the survey control networks and to the change of ellipsoid, the latitude and longitude also change slightly from one datum to the other.

These changes are given in the same order as the entries in the 1927 table, except that *only the changes are shown*. All parameters not listed remain as before, except for the different ellipsoid and datum. Because all coordinates at the origin have been changed, and because they vary considerably, the coordinates are presented in the body of the table rather than as footnotes. Somoa is not being changed to the new datum.

Table 6-2.—U.S. State plane coordinate systems – 1983 datum

[L indicates Lambert Conformal Conic]			
Area	Projection		Zones
California	L		6
Montana	L		1
Nebraska	L		1
Puerto Rico and Virgin Islands	L		1
South Carolina	L		1
Wyoming	Unresolved		
Transverse Mercator projection			
Coordinates of origin (meters)			
Zone	x	y	Other Changes
Alabama			
East	200,000	0	
West	600,000	0	
Alaska, 2-9	500,000	0	
Arizona, all	213,360	0	Origin in Intl. feet <sup>1</sup>

# FIELD MANUAL

Table 6-2.—U.S. State plane coordinate systems – 1983 datum  
(continued)

Transverse Mercator projection (continued)			
Coordinates of origin (meters)			
Zone	<i>x</i>	<i>y</i>	<i>Other Changes</i>
Delaware	200,000	0	
Florida			
East, West	200,000	0	
Georgia			
East	200,000	0	
West	700,000	0	
Hawaii, all	500,000	0	
Idaho			
East	200,000	0	
Central	500,000	0	
West	800,000	0	
Illinois			
East	300,000	0	
West	700,000	0	
Indiana			
East	100,000	250,000	
West	900,000	250,000	
Maine			
East	300,000	0	Lat. of origin 43°40' N.
West	900,000	0	
Mississippi			
East	300,000	0	Scale reduction 1:20,000, Lat. of origin 29°30' N. Scale reduction 1:20,000, Lat. of origin 29°30' N.
West	700,000	0	
Missouri			
East	250,000	0	
Central	500,000	0	
West	850,000	0	
Nevada			
East	200,000	8,000,000	
Central	500,000	6,000,000	
West	800,000	4,000,000	
New Hampshire	300,000	0	

## MAPPING

Table 6-2.—U.S. State plane coordinate systems – 1983 datum  
(continued)

Transverse Mercator projection (continued)			
Coordinates of origin (meters)			
<i>Zone</i>	<i>x</i>	<i>y</i>	<i>Other Changes</i>
New Jersey	150,000	0	Central meridian 74°30'W. Scale reduction 1:10,000.
New Mexico			
East	165,000	0	
Central	500,000	0	
West	830,000	0	
New York			
East	All parameters identical with above New Jersey zone.		
Central	250,000	0	
West	350,000	0	
Rhode Island	100,000	0	
Vermont	500,000	0	
Wyoming	Unresolved		
Lambert Conformal Conic projection			
Coordinates of origin (meters)			
<i>Zone</i>	<i>x</i>	<i>y</i>	<i>Other Changes</i>
Alaska, 10	1,000,000	0	
Arkansas			
North	400,000	0	
South	400,000	400,000	
California			Zone 7 deleted.
1-6	2,000,000	500,000	
Colorado, all	914,401.8289	304,800.6096	
Connecticut	304,800.6096	152,400.3048	
Florida, North	600,000	0	
Iowa			
North	1,500,000	1,000,000	
South	500,000	0	
Kansas			
North	400,000	0	
South	400,000	400,000	
Kentucky			
North	500,000	0	
South	500,000	500,000	

## FIELD MANUAL

Table 6-2.—U.S. State plane coordinate systems – 1983 datum  
(continued)

Lambert Conformal Conic projection (continued)			
Coordinates of origin (meters)			
<i>Zone</i>	<i>x</i>	<i>y</i>	<i>Other Changes</i>
Kansas			
North	400,000	0	
South	400,000	400,000	
Kentucky			
North	500,000	0	
South	500,000	500,000	
Louisiana			
North	1,000,000	0	Lat. of origin 30°30' N.
South	1,000,000	0	Lat. of origin 28°30' N.
Offshore	1,000,000	0	Lat of origin 25°30' N.
Maryland			
	400,000	0	Lat. of origin 37°40' N.
Massachusetts			
Mainland	200,000	750,000	
Island	500,000	0	
			GRS 80 ellipsoid used without alteration.
Michigan			
North	8,000,000	0	
Central	6,000,000	0	Long. of origin 84°22'W.
South	4,000,000	0	Long. of origin 84°22'W.
Minnesota, all			
	800,000	100,000	
Montana			
(single zone)	600,000	0	Standard parallels, 45°00' and 49°00' N. Long. of origin 109°30' W. Lat. of origin 44°15' N.
Nebraska			
(single zone)	500,000	0	Standard parallels, 40°00' and 43°00' N. Long. of origin 100°00' W. Lat. of origin 39°50' N.
New York			
Long Island	300,000	0	Lat. of origin 40°10' N.
North Carolina			
	609,621.22	0	
North Dakota, all			
	600,000	0	
Ohio, all			
	600,000	0	

## MAPPING

Table 6-2.—U.S. State plane coordinate systems – 1983 datum  
(continued)

Lambert Conformal Conic projection (continued)			
Coordinates of origin (meters)			
<i>Zone</i>	<i>x</i>	<i>y</i>	<i>Other Changes</i>
Oklahoma, all	600,000	0	
Oregon			
North	2,500,000	0	
South	1,500,000	0	
Pennsylvania, all	600,000	0	
Puerto Rico and Virgin Islands	200,000	200,000	(Two previous zones identical except for <i>x</i> and <i>y</i> or origin.)
South Carolina (single zone)	609,600	0	Standard parallels, 32°30' and 34°50' N. Long. of origin 81°00' W. Lat. of origin 31°50' N.
South Dakota, all	600,000	0	
Tennessee	600,000	0	Lat. of origin 34°20' N.
Texas			
North	200,000	1,000,000	
North Central	600,000	2,000,000	Central meridian 98°30' W.
Central	700,000	3,000,000	
South Central	600,000	4,000,000	
South	300,000	5,000,000	
Utah			
North	500,000	1,000,000	
Central	500,000	2,000,000	
South	500,000	3,000,000	
Virginia			
North	3,500,000	2,000,000	
South	3,500,000	1,000,000	
Washington, all	500,000	0	
West Virginia, all	600,000	0	
Wisconsin, all	600,000	0	

NOTE: All these systems are based on the GRS 80 ellipsoid.

<sup>1</sup> For the International foot, 1 in = 2.54 cm, or 1 ft = 30.48 cm.

## FIELD MANUAL

### **Units**

English or metric units should be selected as early in the project as possible. Conversions are possible, but converting a large 1-foot contour map to meters is no trivial matter.

Remember that when using several sources of location data, the reference datum must be known. Systematic differences in location data are generally due to mixing datums.

### **Specific Nomenclature and Definitions**

Establish a uniform nomenclature system with written definitions for rock types, map units, and map symbols used. The American Geologic Institute *Glossary of Geology* [2] is the standard for geologic terms except where Reclamation has established definitions for its own needs. These definitions and nomenclature are discussed in chapters 2 through 5.

### **Field Equipment and Techniques**

General geologic mapping equipment and techniques are discussed in field geology manuals such as Lahee (1961) [3] and Compton (1985) [4]. Refer to these texts for discussions of suggested field equipment and general geologic mapping techniques.

### **Use of Computers**

Computers are used during a mapping program in four basic ways: (1) to process and analyze voluminous numerical data (e.g., joint data), (2) as a tool in the analysis of basic geologic data (e.g., construction of preliminary or final plan and section views which

## MAPPING

incorporate previously entered geologic data), (3) Computer Aided Drafting and Design (CADD) of section and plan views, and (4) in modeling geologic conditions. How computers will be used in the reduction, analysis, and drafting of the geologic data generated during a mapping program needs to be decided early because records of field data will depend on whether data are to be stored in digital format and restructuring these data at a later date is costly, time consuming, and introduces transcription errors.

### **Right-of-Way**

Right-of-way is needed for any mapping of non-Reclamation land and should be obtained early to prevent work delays. Although "walk on" permission usually is obtained easily, permission for trenching and drilling may take several months, especially if archeological or environmental assessment is necessary.

### **Records**

Systematic methods of recording field observations, traverse data, outcrop data, and trench logs are important. Suggested sample field book formats are shown under each section below dealing with specific mapping procedures, but any format should allow clear representation of the field data.

### **Geologic Considerations**

The following are some key items that should be evaluated during a mapping project. The degree of importance varies with the project but the factors are common to most.

## FIELD MANUAL

**Lithology.**—Differentiation between the various geologic deposits and lithologies in a study area is basic to geologic mapping. However, an engineering geologist is more concerned with the engineering characteristics of the unit than with its geologic definition, and these characteristics should be the controlling factor in how geologic units are subdivided. For some engineering geologic purposes, it may be reasonable to consolidate geologic units with similar engineering properties into a single engineering geologic map unit. Depending on the needs of the project, lithologic subunits may be defined jointly between the engineers and the geologists working on the job.

After the basic geologic subdivisions for a mapping job have been agreed upon, detailed descriptions of each subunit should be compiled and mapping symbols selected. Map unit definitions usually will apply specifically to the job or project area and normally will be modified as additional data are collected. Map symbols fall into several categories. American Geological Institute data sheets have a comprehensive tabulation of symbols.

**Geologic contacts.**—Two different line types normally are used on geologic maps to denote the precision and accuracy of geologic contacts. These are solid and broken (dashed or dotted) lines. Solid lines usually are used where exposures are excellent, such as a cleaned foundation or an area with nearly continuous outcrops. Solid lines indicate that the contacts are located with a prescribed degree of accuracy. Broken contacts are used when unsure of the accurate location of the contact, i.e., when the contact is covered by thin slopewash deposits (dashed line) or where the contact is buried by deep surficial deposits (dotted line). Confidence levels, expressed in feet or meters, for both types of contacts should be stated clearly in the definition of the contact



## MAPPING

line. The mapper should keep in mind the type of geologic data being compiled and use the appropriate line.

**Discontinuities.**—Discontinuities separate geological materials into discrete blocks that can control the stability and bearing capacity of a foundation or slope. Intersecting discontinuities in cut slopes can form unstable wedges. Because of the destabilizing or weakening effects, mapping and adequately describing discontinuities is critical in engineering geology studies. The various types of discontinuities and the terminology for describing their engineering properties are discussed in chapter 5.

**Weathering and alteration.**—The mechanical and chemical alteration of geological materials can significantly affect stability and bearing strengths. Adequately determining weathering depths, extent of altered materials and the engineering properties of these weathered and altered materials is critical in engineering geologic mapping. Refer to chapter 4 for definitions of weathering and alteration descriptors.

**Water.**—The location and amount of groundwater to be expected in an excavation and how it can be controlled is critical to the overall success of a project.

**Geomorphology.**—Study of landforms is often the key to interpreting the geologic history, structure, lithology, and materials at a site. Exploration programs can be better designed and implemented using landforms as a basis. The geomorphic history is important in determining the relative age of faults.

**Vegetation indicators.**—Differences in vegetation types and patterns can provide indirect data on lithologies, dis-continuities, weathering, groundwater,

## FIELD MANUAL

and mineralization. The water holding capacity of soil developed on one rock (e.g., shale) may differ considerably from the water holding capacity of soil developed on another type of rock (e.g., sandstone); consequently, the types of vegetation that grow in these soils can vary considerably. Minerals present in the parent rock may affect soil chemistry and may limit vegetation to types tolerant of highly acidic or alkaline soils or high concentrations of trace elements. Vegetation seeking groundwater moving up major joints and faults will form vegetation lineations that are highly visible on aerial photographs, particularly color infrared photographs. In most locations, local conditions have to be assessed to use vegetative indicators effectively.

**Cultural features (manmade).**—Cultural features, such as water, gas or oil wells, road cuts or foundation excavations, can provide surface and subsurface data and should be reviewed early in the mapping project. When data collection through trenching and core drilling programs is considered, buried utility lines (water, gas, electrical, sewage, or specialized lines) can be hazardous or embarrassing when broken. Usually the utility or owners will locate their lines.

**Field checking.**—Field checking by both mapper and independent reviewer is a critical part of the mapping process. Field checking after a map is complete allows the mapper to check the interpretations at a given location with the geologic concepts developed on the map as a whole. Field checking by the independent reviewer ensures that the basic field data are correct and conform to project standards. Periodic field checking of previously mapped areas can be useful as the mapper's concept of the site geology changes with the addition of new surface and subsurface data.

## MAPPING

### Site Mapping

Engineering geologic mapping has two phases—mapping prior to construction and mapping during construction. In general, the following guidelines are for: (1) general mapping requirements, (2) suggested equipment, (3) specific preparations needed for the job, (4) type of documentation needed, and (5) special considerations that the mapping may require.

#### General

Detailed site geologic mapping studies generally are done for most structures or sites. Site mapping requirements are controlled by numerous factors, the most important of which are the type and size of structure to be built or rehabilitated or site to be remediated, the phase of study (planning through operation and maintenance), and the specific design needs.

Site mapping studies for major engineering features should be performed within an approximate 5-mile (8-km) radius of the feature, with smaller areas mapped for less critical structures. These studies consist of detailed mapping and a study of the immediate site, with more generalized studies of the surrounding area. This approach allows an integration of the detailed site geology with the regional geology. The overall process of site mapping is a progression from preliminary, highly interpretive concepts based on limited data to final concepts based on detailed, reasonably well-defined data and interpretation. This progression builds on each previous step using more detailed methods of data collection to acquire better defined geologic information. Typically, site mapping is performed in two phases: (1) preliminary surface geologic mapping and (2) detailed surface geologic mapping. All site mapping studies begin

## FIELD MANUAL

with preparation of a preliminary surface geologic map which delineates surficial deposits and existing bedrock exposures. The preliminary surface geologic map is then used to select sites for dozer trenches, backhoe trenches, and drill holes. Surface geologic maps are then re-interpreted based on the detailed surface and subsurface data. If required, detailed subsurface geologic data are also obtained from exploratory shafts and adits.

### **Suggested Equipment**

The following list of basic equipment should meet most needs. Not all listed equipment is necessary for every project, but a Brunton Compass, geologist's pick, (2-pound hammer may be necessary for rock sampling), maps, map board, aerial photographs, notebook, scale, tape measure, protractor, knife, hand lens, various pens and pencils, and a GPS should meet most needs.

### **Preparation**

Whether a site mapping program is completed in one field season or over several years, the overall project schedule and budget are critical. A critical assessment should be made of the time available for the mapping program, the skills and availability of personnel to accomplish the work, weather conditions, and budget constraints.

### **Documentation**

Site data are documented on drawings (and associated notes) generated during the study. The drawings fall into two general categories—working drawings and final drawings. Working drawings serve as tools to evaluate and analyze data as it is collected and to define areas where additional data are needed. Analysis of data in a three-dimensional format is the only way the geologist

## MAPPING

can understand the site geology. Drawings should be generated early in the study and continuously updated as the work progresses. These drawings are used for pre-liminary data transmittals. Scales used for working drawings may permit more detailed descriptions and collection of data that are not as significant to the final drawings. Final drawings are generated late in the mapping program, after the basic geology is well understood. Many times new maps and cross sections are generated to illustrate specific data that were not available or well understood when the working drawings were made. Final drawings serve as a record of the investigations for special studies, specifications, or technical record reports.

**Preliminary Surface Geologic Mapping.**—The purpose of preliminary surface geologic mapping is to define the major geologic units and structures in the site area and the general engineering properties of the units. Suggested basic geologic maps are a regional reconnaissance map at scales between 1 inch = 2,000 feet and 1 inch = 5,280 feet (1:24,000 to 1:62,500), and a site geology map at scales between 1 inch = 20 feet and 1 inch = 1,000 feet (1:250 to 1:12,000). Scale selection depends on the size of the engineered structure and the complexity of the geology. Maps of smaller areas may be generated at scales larger than the base map to illustrate critical conditions. Cross sections should be made at a natural scale (equal horizontal and vertical) as the base maps unless specific data are better illustrated at an exaggerated scale. Exaggerated scale cross sections are generally not suited for geologic analysis because the distortion makes projection and interpretation of geologic data difficult.

Initial studies generally are a reconnaissance-level effort, and the time available to do the work usually is limited.

## FIELD MANUAL

Initially, previous geologic studies in the general site area are used. These studies should be reviewed and field checked for adequacy and new data added. Initial base maps usually are generated from existing topographic maps, but because most readily available topography is unsuitable for detailed studies, site topography at a suitable scale should be obtained if possible. Existing aerial photographs can be used as temporary base maps if topographic maps are not available. Sketch maps and Brunton/tape surveys or GPS location of surface geologic data can be done if survey accuracy or control is not available or necessary. Good notes and records of outcrop locations and data are important to minimize re-examination of previously mapped areas. Aerial photography is useful at this stage in the investigation, as photos can be studied in the office for additional data. Only after reasonably accurate surface geology maps have been compiled can other investigative techniques, such as trenching and core drilling, be used to full advantage. For some levels of study, this phase may be all that is required.

**Detailed Surface Geologic Mapping.**— The purpose of detailed surface geologic mapping is to define the regional geology and site geology in sufficient detail so geologic questions critical to the structure can be answered and addressed. Specific geologic features critical to this assessment are identified and studied, and detailed descriptions of the engineering properties of the site geologic units are compiled. Project nomenclature should be systematized and standard definitions used. Suggested basic geologic maps are similar to those for preliminary studies, although drawing scales may be changed based on the results of the initial mapping program. Maps of smaller areas may be generated to illustrate critical data at scales larger than the base map.

## **MAPPING**

The preliminary surface geology maps are used to select sites for dozer trenches, backhoe trenches, and drill core holes. As the surface geology is better defined, drill hole locations can be selected to help clarify multiple geologic problems. Detailed topography of the study site should be obtained, if not obtained during the initial investigations. Data collected during the preliminary investigations should be transferred to the new base maps, if possible, to save drafting time. Field mapping control is provided primarily by the detailed topographic maps and/or GPS, supplemented by survey control if available or Brunton/ tape survey. If not, large scale aerial photographs of a site area flown to obtain detailed topography are useful in geologic mapping.

### **Dozer Trench Mapping**

#### **General**

Dozer trenches are cut to expose rock or unconsolidated materials below the surface and major surface creep. Walls normally should be excavated vertically, free of narrow benches and loose debris. Upon completion of excavation, floors must be cleaned below any depth of ripping, loose rubble should be removed, and a new surface exposed. Structures such as contacts and shear zones must be traceable from wall into floor for optimum determination of their nature and attitude. The geologist is responsible to ensure the dozer operator produces a safe finished trench that meets Reclamation and Occupational Safety and Health Administration (OSHA) safety standards. If livestock are present, fencing of the trench with four strands of barbed wire may be required. After trench logging is completed, decide whether to leave the trench open or to backfill. At sites with complex geology, it is desirable to leave the

## FIELD MANUAL

trench open for reinterpretation of the trench in light of newly acquired data. Backfilling of the dozer trench may be necessary where an open trench would be a safety hazard. Generally, all trenches should be backfilled and com-pacted prior to abandonment.

### **Suggested Equipment**

Additional equipment needed may include hard hat, scraper or putty knife, square-nosed shovel, plastic flagging, nails, wooden stakes, surveyors chain or tape measure (feet or meters) and log book. Use putty knife, shovel, and whisk broom for cleaning trench exposures and a Brunton tripod for more accurate trench bearings.

### **Preparation**

Prior to working in a dozer trench, the geologist should inspect the excavation trench walls for failure planes (obvious or incipient) or loose materials. These should be removed before mapping starts. An examination of the whole trench should be made at the start of each work period. A baseline should be laid out along the toe of the trench wall or at the top of the excavation. Because dozer trenches often are not straight, the trench should be divided into a series of straight segments with stations established at each point where the trench changes direction. Each station should be marked by a stake, tied with flagging, and marked with the trench number and station letter (e.g., DT-12A). Flagging strips should be nailed to the wall approximately 6 feet (2 meters [m]) vertically above or below the station for another reference point in case minor sloughing buries or dislodges the stake.

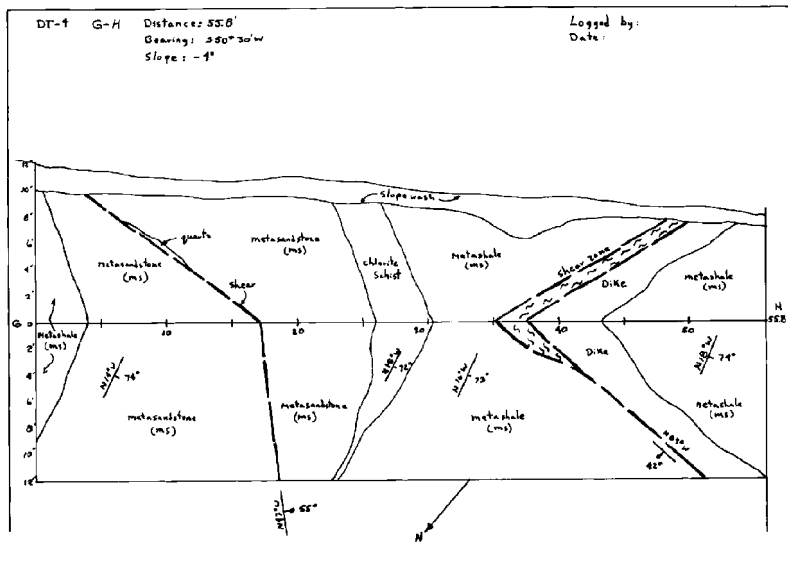


## MAPPING

### Documentation

The scale and format selected for logging a backhoe trench depends on the type of data needed and the amount of detail to be illustrated. Typical dozer trench log scales are between 1 inch (in) = 5 feet (ft) (1:100) and 1 in = 10 ft (1 : 200), but scales of 1 in = 1 ft (1: 50) may be required in critical areas to adequately show structural and stratigraphic details. If trench geology is not complex, record trench logs, along with names of the field party and date in a field book. Determine and record the bearing, slope distance, and slope angle between each station. Survey the coordinates and elevations of each station. Orient the log book so the sketch and description may be viewed together (see figure 6-2). Sketch the walls and floors across the top page of the open log book. Mark the baseline at 5-foot (1.5-m) intervals and draw a single "hinge line"; wall above, floor below. Determine the vertical heights of the trench walls at each station and between stations, if the profile or thickness of surficial materials changes between stations.

Sketches should be accurate and illustrate the field relationship of soil and geologic units and structures. Use nails and flagging strips to mark obscure contacts or other features for ready reference during logging. Designate geologic units by name and symbol. Accurately plot the attitude of contacts, bedding, foliation or cleavage, faults, shear zones, and joints where they are determined using standard symbols, and write a description. If attitudes are determined from the wall, they may be projected along strike into the floor, if no change is apparent in the floor. Note and show the bedding or foliation wherever relationships are complex and differ from the recorded attitude (i.e., where surface creep, drag folds, or disturbed zones are exposed in the wall). Record unit attitudes that may have been affected



## MAPPING

by surface creep or slumping. Written descriptions of soil and rock units and structural zones should be restricted to the page below the sketch and should not be written over the sketch. Main heading for written descriptions are restricted to mappable geologic units. Intervals are noted where the contacts intersect the baseline. Indent subheadings within text to describe lithologic or structural variations within the mappable unit. An example of heading order is as follows:

DT-58, Sta. B-C, Distance - 27.5', Bearing - S. 45°  
W.,  
Slope + 2  
22.5-50.0': Metasediments (description)  
39.9-41.0': Chlorite Schist B (description)  
47.5-49.0': Talc Schist (description)  
48.2-48.4': Shear Zone (description)

Stratigraphic units should be colored to complete the log. Photograph the trench to complement the log or to record specific details within the trench.

### **Backhoe Trench Mapping**

#### **General**

Backhoe trenches are excavated to expose rock or unconsolidated materials below surficial deposits and major surface creep. Generally, backhoe trenches are excavated at sites which must be returned to near-original conditions and where dozer trenching would produce unacceptable damage. Backhoe trenches often are excavated in the floor of an existing dozer trench to deepen the excavation. Walls should be excavated vertically and free of narrow benches and loose debris. In most cases, the trench should be about 3 to 3-1/2 feet wide (1 m) (width of standard backhoe bucket), 10 to 12

## FIELD MANUAL

feet (3 to 3.6 m) deep, and slope at one end for easy access. Upon excavation completion, hydraulic trench shores are placed and pressurized or wooden shores constructed to support the trench walls. Shore construction and spacing must meet OSHA standards and standards outlined in Reclamation's *Construction Safety and Health Standards* manual. At no time should personnel enter unshored portions of the trench over 5 feet deep. The geologist who oversees the excavation of the backhoe trench is responsible for the construction of a safe, stable trench.

After trench logging is completed, decide whether to leave the trench open or to backfill. At sites with complex geology, leave the trench open, if possible, as this allows reinterpretation of the trench in light of newly acquired data. However, backhoe trenches are prone to sloughing with time, even when supported, and backfilling of the trench may be necessary for safety reasons. The coordinates and elevation of each end of the backhoe trench should be surveyed prior to backfilling.

### **Suggested Equipment**

Standard field equipment is used during backhoe trench mapping. Additional equipment may include a hard hat, large knife, flat-blade pick or army trenching tool to clean off trench walls, putty knife, whisk broom, nails, flagging, twine, small string level, 100-foot (30-m) long surveyor's chain or tape, and map board or log book. The type of backhoe needed depends on how consolidated or cemented the material is, site accessibility, and depth to be excavated. Most of the larger, rubber-tired backhoes are suitable for excavation of typical trenches, but well consolidated or cemented material, steep site terrain, or trench depths over about 12 feet (3.6 m) may require a larger track-mounted hydraulic excavator.

## MAPPING

### Preparation

Each day prior to working in a backhoe trench, the trench along both sides and the trench walls should be examined for incipient fractures or loose materials, particularly within the surficial materials. These loose materials should be removed before work starts. Hydraulic trench shores should be checked visually for leakage and for loss of pressure by pushing on them with a foot. Re-pressure any loose shores and replace leaking shores. The stability of each shore should be checked before the mapper's weight is put on it, particularly if the shore is to be used to examine the upper trench wall or to climb out of the trench.

A backhoe trench must be cleaned prior to logging. During excavation, the backhoe bucket may smear clay and silt along the walls, obscuring structural and stratigraphic relationships. This smeared zone may be anywhere from a fraction of an inch thick to several inches thick, depending on the amount of fines and moisture in the material excavated. The smeared material can be removed by chipping or scraping with a large knife, flat-bladed pick, or army trenching tool. If the trench is excavated in reasonably consolidated material and the trench is free draining, a high pressure water and/or air jet will remove this material. Both walls should be spot cleaned and examined prior to major cleaning to determine which wall exposes the best geologic data. Usually only one wall is completely cleaned; the other wall is spot cleaned during trench logging to expose another view of critical features or relationships. After a wall is cleaned, a horizontal base line is established. The baseline is run at about eye level and constructed by stringing twine between nails driven into the cleaned trench wall. The twine can be leveled using a small string level (available in most hardware stores) prior to driving nails. When the baseline becomes either too high or too low for

## FIELD MANUAL

comfort-able measurements, a vertical offset of the string line is made and the baseline continued at the new horizon. In complex, critical areas where accurately located contacts are needed, a string grid with horizontal and vertical elements can be constructed off the baseline to assist in mapping.

### **Documentation**

The scale and format selected for logging a backhoe trench depends on the type of data needed and the amount of detail to be illustrated. Typical backhoe trench log scales are between 1 in = 5 ft (1:100) and 1 in = 10 ft (1 : 200), but scales of 1 in = 1 ft (1 : 50) may be required in critical areas to adequately show structural and stratigraphic details. If trench geology is not complex, a notebook is suggested. The log book should be oriented so the sketch and description may be viewed together. The names of the field party, date, trench number, location, and other pertinent data should be recorded. If trench geology is complex and a larger scale is desired, cut sheets of grid paper attached to a map board may be used. These sheets are usually redrafted after trench logging is completed. If the backhoe trench is wet or wall material is sloughing down onto the map board, a blank grid sheet can be taped to the map board and overlain by sheets of mylar. Trench data sketched onto the mylar will not be smeared as easily, and the sheets can be erased without tearing. Prints of the sheets can be made for use in preliminary data transmittal or as check prints for field checking. Figure 6-3 shows a completed trench log.

Because the log sheets are separated easily, each sheet should be marked with the names of the field party, date, trench number, location, and other pertinent data.

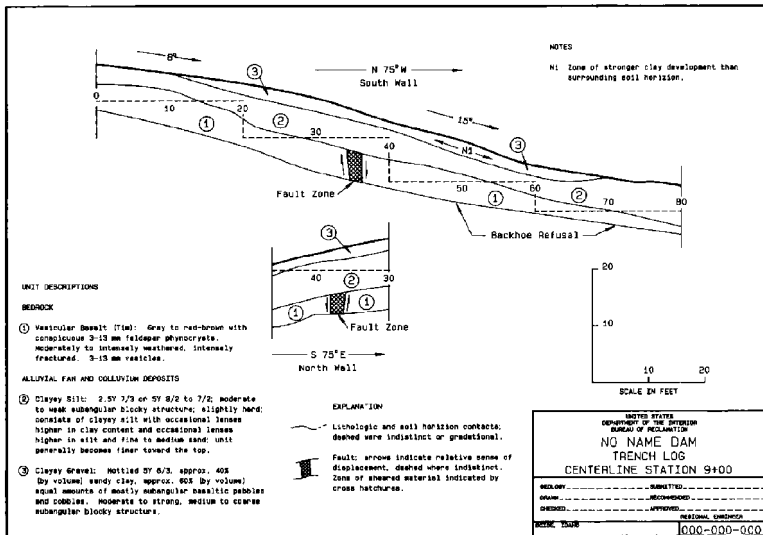


Figure 6-3.—Sample completed trench log.

## FIELD MANUAL

Begin trench logging by recording the trench bearing. Begin at one end of the trench; place a surveyors chain or tape along the horizontal base line string. Vertical distance of the trench wall above and below the base line should be measured every 10 feet (3 m) or so and the trench outlines sketched. Sketches must be as accurate as possible to illustrate the field relationships of soil, geologic units, and structures. Use flagging to mark obscure contacts or other features for easier logging.

Intervals for the various geologic units and features are to be noted where the contacts intersect the baseline. Contacts above and below the baseline are located by two measurements—the vertical distance from the baseline and baseline distance—and sketched onto the log. Geologic units should be designated by name or symbol. Symbols to illustrate the attitude of contacts, bedding, foliation or cleavage, faults, shear zones, and joints should be drawn at the point where determined and also re-corded in the written description. Bedding or foliation should be depicted and noted wherever relationships are complex and differ from the recorded attitude (i.e., where surface creep, drag folds, or disturbed zones are exposed in the wall). Attitudes on units that may have been affected by surface creep or slumping should also be so noted.

Written descriptions of soil and rock units and structural zones should be restricted to the area below the sketch. Main headings for written descriptions are restricted to mappable geologic units. Description format is similar to that discussed for dozer trench mapping. After trench logging is completed, geologic units should be colored to complete the log and the trench field checked. Photograph the trench to complement the trench log or to record specific details within the trench. The limited space and poor lighting conditions in a backhoe trench



## MAPPING

many times make it difficult to obtain satisfactory photos. Generally, cameras capable of closeup focusing and loaded with fast film work best. Photographs taken while standing at the top of the trench generally are marginal because of poor lighting and perspective. The ends of the trench should be located by GPS or survey.

### **Construction Geologic Mapping**

Geologic mapping during construction is to: (1) identify and delineate potential or actual construction-related needs and problems; (2) verify and better define geologic interpretations made during design studies, particularly for critical geologic features and properties; (3) determine if the geologic conditions are as interpreted during the design phase and ensure that the actual conditions revealed are as interpreted. If those conditions are not as interpreted, design modifications may be required; and (4) provide a record of as-built conditions in the event of litigation or operational problems.

To obtain meaningful data for mapping during construction, cooperation and coordination between the Contractor and the construction staff is required. The field geologist prioritizes mapping; and when the specific area is ready for mapping and approval, the staff and surveyors (if required) should accomplish the work as quickly as possible. Photographs should be taken using appropriate photographic equipment. All photographs should be captioned and dated.

Possible safety hazards that might occur during mapping should be evaluated, and appropriate precautions should be taken.

## FIELD MANUAL

### Large Excavation Mapping

#### General

Construction considerations prepared before construction begins should contain guidelines for the mapping of specific features. The scope and detail of mapping required at each portion of the site should be determined and suitable mapping scales determined. Suggested scales for detailed foundation mapping are 1 in = 5 ft to 1 in = 50 ft (1:50 to 1: 600), generalized foundation invert map scale 1 in = 20 ft to 1 in = 100 ft (1:20 to 1:1,000). Detailed, as-built foundation geology maps are used in final design modification, as a final record, and for use in possible future operation and maintenance problems. Mapping can be done on detailed topographic base maps generated from survey control, GPS, or plane table. Preferably, geology points are flagged and surveyed by a survey crew. Terrestrial photography, photogrammetry, and GPS can also be used to supplement mapping. Detailed photo-graphy of the entire foundation is important for inclusion in the final construction geology report and as a part of the construction record. Use standard nomenclature and symbols both on maps and photographs, but be consistent with those used in earlier studies and specifications. Use a systematic method of collecting mapping data, then compile these data into a useful and accurate geologic map.

Detailed, as-built geology maps of cutslopes are required in delineating and solving major slope stability problems and in selecting general slope support systems. Recommended scale selection for detailed cut-slope geology maps are 1 inch = 10 feet to 1 inch = 50 feet (1:100 to 1:600), generalized cutslope geology maps use a scale 1 inch = 20 feet to 1 inch = 100 feet (1:200 to 1:1,000). Generally, maps are on detailed topographic base maps

## MAPPING

generated from survey control. Geologic points may be flagged for survey by survey crews. Detailed photographs of the slopes are important.

### **Steep Slope Mapping**

#### **General**

Define the purpose and goal for mapping and research the stratigraphy and structural geology prior to starting. Select scaling and safety equipment for specific areas.

#### **Preparation**

Special training is required for scaling. While scaling and mapping, a pocket tape recorder and camera are useful for documentation.

#### **Suggested Equipment**

Use the appropriate scaling equipment and systems. Standard mapping equipment needs to be reviewed and modified for scaling operations.

#### **Documentation**

Establish ground control for mapping including terrestrial photo mapping. Data collected while scaling should be based on the purpose of mapping and detail required. Establish general map controls such as grid controls.

#### **Special Considerations**

Select specific portions of an exposure to be mapped.

## FIELD MANUAL

### Canal and Pipeline Mapping

#### General

In reconnaissance investigations, surface geologic mapping is used to determine the most feasible alignment, which may be representative of the geologic conditions to be encountered, the lining requirements, and construction materials available. Design data investigations along canal alignments must be detailed enough to determine the final alignment and all associated requirements for specifications and construction.

Preconstruction investigations for canals and pipelines are less detailed because of the long distances involved. Consequently, geologic construction mapping is necessary to verify preconstruction assumptions, document changes from original assumptions, and provide data for potential design changes or claim analyses.

#### Preparation

General field mapping requirements.

#### Documentation

Pertinent geologic data that should be shown on the base maps include: soil and geologic units, all natural and manmade exposures, geologic structures, springs and seepage, surface channels, and potentially unstable areas. Where appropriate, photographs with overlays or detailed site-specific drawings should be used to show surface conditions in relation to the canal prism or associated canal structures. Base maps should be plan strip topography or orthophotography with scales of 1 in = 20 ft (1:400) to 1 in = 100 ft (1:2,000) with associated topographic profiles.

# MAPPING

## Underground Geologic Mapping

### General

This is a general guide for recording tunnel geology and describes mapping requirements and procedures. This guide and the field geologist's judgement and experience should permit development of geologic data which adequately document geologic factors that are significant to design, construction, and stability of tunnels and shafts. Some of the necessary data may be obtained from other project personnel such as engineers, surveyors, and inspectors. The following items are of primary importance during the construction or exploration for a wide range of tunnel and shaft types, excavation problems, geologic conditions, and contract administration requirements. The data recorded and the emphasis given each item should be determined for each specific tunnel. (Note: references to tunnels apply equally to shafts)

Three principal objectives are to:

- Acquire progressive, timely mapping of all significant geologic features as exposed during the advance of the tunnel or shaft. These initial features are important for subsequent identification of changes which may take place, such as water flow, rock slaking, or support behavior, as the heading progresses and before lining or other completion measures are undertaken.
- Facilitate periodic transmittal of these data in preliminary form to the office so that conditions being encountered and their effect on the excavation can be used in immediate evaluation of current construction activities and anticipation of future excavation conditions.

## FIELD MANUAL

- Assure that a systematic, clear, record of geologic conditions is compiled for design reviews and use by the project and contractor. These data should be included in the final construction geology report. These records may prove invaluable during subsequent operation and maintenance and in the planning and design of future tunnels and shafts. If geologically related problems occur, these data will be essential in evaluating the conditions.

Accuracy is essential, and consistency of data shown on tunnel maps is vital. If the maps are used in contract claim negotiations or in litigation, even a few errors or inconsistencies may compromise the entire map.

The preparation of an adequate tunnel or shaft geologic map requires a careful study of geologic structure, lithology, mineralogy, groundwater, and their effects on rock quality and behavior, tunneling methods, stability, and support. The preparation of a tunnel or shaft geologic map is a geologic mapping process; geologic data should be recorded directly on the map while making the observations and not described in notes for subsequent drafting in the office. An appropriately scaled tunnel or shaft mapping form, prepared prior to starting the mapping, is essential to systematic data collection. One-matte-sided mylar tunnel forms should be used in wet excavations and are recommended as a standard for all tunnel and shaft mapping. Figures 6-4 and 6-5 are examples of field mapping forms. The use of mylars in all tunnels facilitates copying and immediate use. The extent or amount of mapping detail for a specific tunnel or shaft will depend on the driving method, geologic conditions, and design considerations. For example, tunnel face (head-ing) maps can be obtained under most conditions when conventional excavation (drill/blast) methods are used but are difficult to obtain in tunnels excavated by tunnel

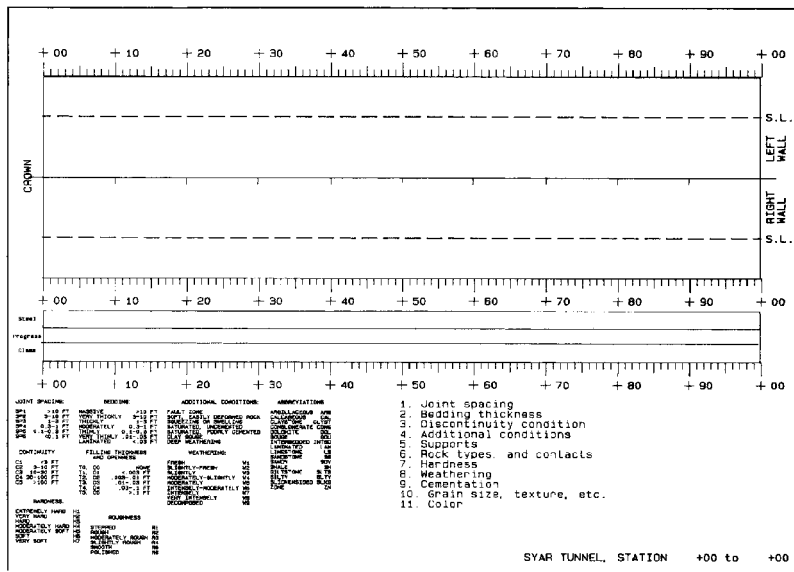


Figure 6-4.—Tunnel mapping form with key alphanumeric descriptors and mapping data.

TUNNEL BEARING:

SECTION

\* Cementation, grain size, joint continuity, openness, filling, etc.

SCALE OF FEET

SYMBOL	LITHOLOGY	BEDDING	JOINT SETS/SPACING	HARD	WEATH.	* Additional descriptors.
1.						
2.						
3.						
4.						
5.						
6.						

FAULT:	Str:	Dip:	Composition:
FAULT:	Str:	Dip:	Composition:

STEEL

CLASS

EXCAVATION PROGRESS

ALWAYS THINK SAFETY  
 UNITED STATES  
 DEPARTMENT OF THE INTERIOR  
 BUREAU OF RECLAMATION  
 CENTRAL UTAH PROJECT  
 BONNEVILLE UNIT - UTAH

STA.    +                      TO STA.    +

GEOLOGY                      FIELD APPROVAL  
 DRAWN                         TECHNICAL APPROVAL  
 CHECKED                      APPROVED  
 DRAWN BY:                      DATE:

66-418-XXXX

**Figure 6-5.—Tunnel mapping form with blocks for title and geologic data.**



## MAPPING

boring machine (TBM). TBM excavated tunnels may be more difficult to map than conventionally excavated tunnels, depending on the level of detail required, machine configuration, and the support method. However, the key rock characteristics relative to tunnel stability must be mapped. In tunnels where shotcrete or precast segments are used for support, detailed mapping may be impossible; this does not cancel the requirement for mapping and recording of important data on the geologic conditions. The geologist must obtain required data with the available resources and under the specific conditions. These guidelines apply to all tunnel or shaft excavations regardless of whether the mapping is performed during project planning, design data acquisition, or construction.

### **Safety**

Underground construction activities are inherently more hazardous than surface construction. Before working underground, the specific safety requirements for the particular tunnel should be determined. Self-rescuer training commonly is required, and the safety requirements as described in the *Reclamation Safety and Health Standards* [5] should be reviewed. Additional training or additional requirements may exist under special circumstances such as gassy conditions. Before beginning work, a familiarization tour of the work site (including the underground workings) should be made with project personnel, such as an inspector, intimately familiar with the job. Also, assume that every piece of equipment and worker is out to get you; you should always maintain an awareness of what the workers and equipment are doing around you.

## FIELD MANUAL

### General Preparation

Tunnel construction is essentially a linear activity. All access, equipment haulage, and work activities take place in a line. The mapping process should be planned such that a minimum number of trips to the heading are required and a minimum amount of time is spent at the heading. Geologic mapping can usually be integrated into an optimum part of the construction cycle. Unnecessarily spending time at the heading is not only inefficient but can interfere with the construction process by adding to an already congested situation.

Available geologic data should be reviewed and established nomenclature used as appropriate. Geologic features described in the available literature should be specifically investigated while mapping, especially those described in specifications documents. Forms should be designed to expedite the work as much as possible (figures 6-4 and 6-5), required mapping equipment must be available, and the construction cycle should be analyzed to determine the best and safest time to map. Tunnel map sheets should be a convenient size such as 8.5 x 11 inches (A4) or 11 x 18 inches (A3). This permits 100 feet (30 m) of tunnel on a scale of 1 inch = 10 feet (1:200) with sufficient space for concise explanations and a title block. The geology should be mapped in the tunnel directly on the matt side of mylar film. This map, developed in the tunnel, can be edited and copied for quick transmittal to the office. The value of current data cannot be overemphasized. Except under very special conditions, the recording of geologic data in a notebook without mapping for subsequent preparation of a graphic tunnel map is unacceptable. Without a graphic representation during data acquisition, the interrelationships of geologic data cannot be properly evaluated, and data are missed or errors are introduced. Some items listed above will not apply to every tunnel,

## MAPPING

and some items may be shown more appropriately in a summary tunnel map (figure 6-6). This map presents a summary of essential engineering and geologic relationships. Plotting engineering and geologic data as a time line permits direct comparison of geologic conditions, supports installed, overbreak, excavation rate, etc., for correlation. Summary sheet scales may range from 1 inch = 10 to 100 feet (1:100 to 1:1,000) depending on amount of data and complexity of the geology. Ongoing maintenance of these data avoids excessive compilation time after construction is completed. A summary tunnel map is required on tunnels for construction records.

When several individuals are mapping and/or contract requirements hinge on geologic data, e.g., payment based on ground classification, a project or specific mapping manual may be necessary. A manual provides an easy reference for data requirements and format, reduces inconsistency between geologists, and sets a specific mapping standard.

### **Excavation Configuration**

Conventionally excavated tunnels are usually a modified horseshoe shape. Departures from this shape are usually for a special configuration or when ground conditions dictate a circular shape for optimizing support effectiveness. Machine-excavated tunnels are round if bored unless a road-header type machine is used. Road-header excavated tunnels are usually horseshoe shaped for construction convenience. Shafts are almost always round for optimizing support effectiveness and because most are drilled or bored either from the surface or raise-bored from the bottom. Exploratory shafts may be sunk conventionally if shallow. Whatever the shape, the map format should be designed to minimize the amount of projection

## FIELD MANUAL

and interpretation required. Whenever possible, the full periphery mapping method should be employed.

### Data Requirements

The relationship of the geology to the engineering aspects of the tunnel or shaft is of primary importance. If geologically related problems occur, the recorded data will be valuable to the geologist and engineer in evaluating the conditions, the cause(s), and in devising remedial measures. In most cases, geologic discontinuities, such as joints, faults, bedding, etc., are the most important factors affecting excavation stability; and these data are of primary importance. Also, the rock strength is important in high cover tunnels, and water is important in many situations. The following data are most important:

**1. Rock Classification.**— Lithology and related features such as foliation, schistosity, and flow structure. Rock descriptions should be concise; use standard descriptors.

- **Formation boundaries** — describe bedding thickness and attitude, areas of soft, or unstable rock. Give dip and strike unless otherwise noted. Dips of planes (not necessarily true dip) into tunnel are desirable in cases where they may influence excavation stability.
- **Physical properties of the rock** — determine hardness by comparison with common or familiar materials, brittleness, reaction to pick or knife, and color.
- **Alteration** — describe degree, type, extent, and effects on construction. Differentiate between weathering, other alteration, and cementation.

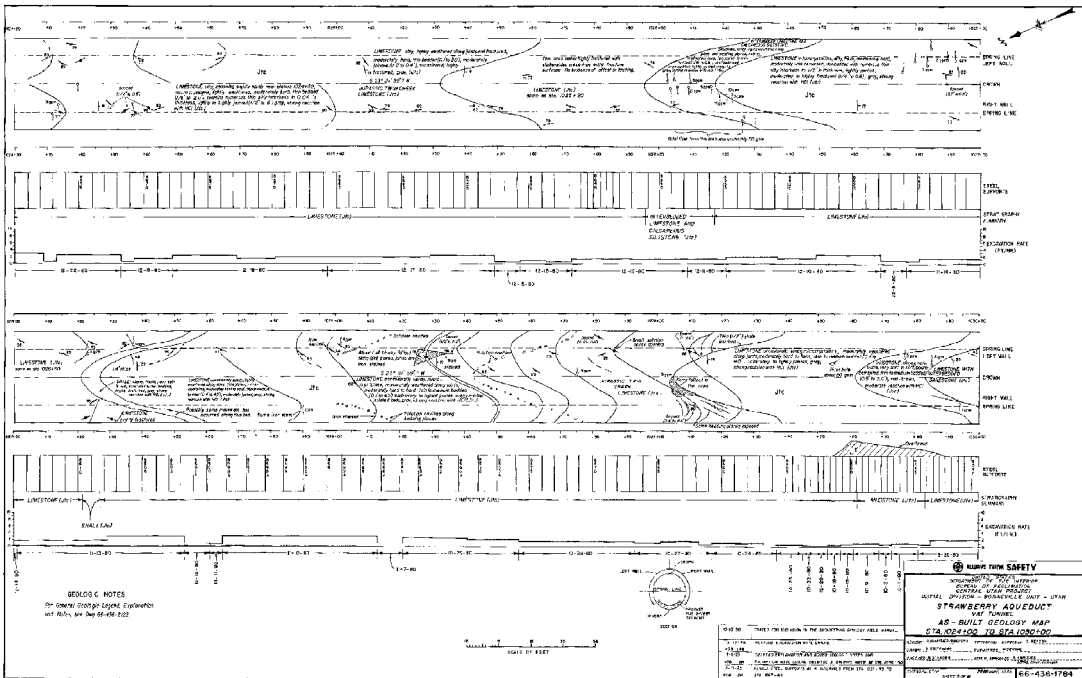


Figure 6-6.—As-built summary geology tunnel map.

## FIELD MANUAL

## MAPPING

- **Features** — describe the size, form (tabular, irregular), contacts (sharp, gradational, sheared), and mineralization, if any.

### 2. Conditions Which Affect Stability of the Rock.—

- **Joints or joint systems** — describe spacing, continuity, length, whether open or tight, slickensides, planarity, waviness, cementation, fillings, dip and strike, and water.
- **Shear zones** — describe severity of shearing and physical condition of rock in and adjacent to the zone, whether material is crushed or composed of breccia, gouge, or mylonite; describe gouge thickness, physical properties, mineralogy and alteration; dip and strike, and water.
- **Faults** — give dimensions of fault breccia and/or gouge and adjacent disturbed or fractured zones, amount of displacement, if determinable, and the fault's effect on stability of rock.

**3. Effects of Tunneling on Rock.**— Comment on: the condition of rock after excavation, rate of air slaking or other deterioration of rock where appropriate, rock bursts, fallouts, development of squeezing or heavy ground, and time interval between first exposure and the beginning of these effects. Include the evidence used in evaluation, and the reaction of different rock types to conventional blasting or mechanical excavation method.

Periodic re-examination of the tunnel and comparison of originally mapped conditions with those existing later is recommended.

### 4. Tunnel Excavation Methods.—

**Blast pattern** — Give example of typical blast round pattern, type of explosive and quantity per yard (powder factor) of rock blasted, size of rock fragments, ease or difficulty of rock breakage and condition of the walls of the tunnel such as whether half-rounds (half of peripheral shot holes) are visible. Some of this information should be obtainable from the inspectors.

**Overbreak** — Overbreak and fallout should be measured as a peripheral average from "B" line (excavation pay line), where practical, and maximum at specific stations. Plot average overbreak on the section along tunnel alignment. Relate this to geologic conditions and construction methods, particularly blasting procedure.

**Ground behavior** — Blockiness, caving, swelling, and/ or squeezing should be described with evidence and effects.

**Supports** — Give size and spacing of ribs, size and types of struts, and behavior of supports in reaches of bad ground. Where supports show distress or have failed, give reason for failure, time after installation for load to develop, the remedial measures undertaken, and size and spacing of replaced supports or jump sets. If a ground classification system is being used, relate to geologic conditions and support used. Incorporate some reference to the actual need for support versus that installed. Use the proper terminology when describing supports. A good reference for tunnel supports (and conventional tunneling) is *Rock Tunneling with Steel Supports* [6].



## MAPPING

Indicate where special supports such as mats, spiling, or breast boards are required and geologic reason. Where rock bolts (or split sets) are used, give spacing, size, length, type, anchor type, torque loading values, and quantities used. Note retorquing, if performed. Locations of rock bolts should be plotted on the geologic maps.

**Machine excavation** — In machine-type excavations (in addition to appropriate items above) give: rate of advance, pressures used, and description of cuttings or rock breakage. Describe the effect of cutters and grippers on rock walls, or other geologically related problems such as abrasive rock wearing cutters.

**5. Hydrogeology.**—Water flows should be mapped and quantities estimated. Daily heading and portal measurements should be recorded. The location of all significant flows should be plotted on the tunnel map and changes in rate or duration of flow recorded. If the water is highly mineralized, obtain chemical analyses of water for possible effect on concrete or steel linings or contamination of water being discharged or to be conveyed by the tunnel.

**6. Gas.**—The following should be done:

- Determine type, quantity, occurrence, geologic associations, and points of discharge should be mapped.
- Samples should be taken. This is usually done by safety personnel.
- Record actions taken.

**7. Instrumentation, Special Tests, Grout, and Feeler Holes.**—Locations and logs (if available) should be shown on the tunnel maps.

## FIELD MANUAL

**8. Miscellaneous Excavations.**—Geologic maps and sections of related excavations such as surge tanks, gate shafts, inlet and outlet portal open cuts are necessary.

Tunnel maps should include brief comments on the geologic conditions being encountered and their possible effects.

**9. Sampling.**—A systematic sampling program of the tunnel rock is essential to adequately record tunnel geology. These samples may be 2 in x 3 in (5 cm x 8 cm) or larger and should be secured in a labeled sample bag showing station, date, and wall position with an appropriate description. Rock that easily deteriorates should be protected with wax or plastic. Sampling at irregular (and locally close) intervals may be required to ensure that all important rock, geologic, and physical conditions are adequately represented. A representative stratigraphic series of samples should be collected. The judgement of the geologist who is familiar with the geology is the best guide in determining the most appropriate sampling interval.

Thorough photographic coverage provides a visual record of construction and geologic conditions. Postconstruction evaluations use construction photographs extensively and are an important part of the construction record. A camera should be part of the mapping equipment and routinely used. Photographs that show typical, as well as atypical, geologic conditions should be taken routinely. Identify photographs of significant features by number on the appropriate map sheet.

## MAPPING

### Underground Geologic Mapping Methods

#### Full Periphery Mapping

The full periphery (or developed surface) mapping method is widely used in engineering practice and involves creating a map of the surface of the underground excavation regardless of shape. The method produces a map which is virtually free from distortion and interpretation present in other methods where geologic features are projected onto a plane or section. The method has been used successfully in various types and shapes of excavations (Hatheway, 1982 [7]; U.S. Army Corps of Engineers, 1970 [8]; Proctor, 1971 [9]) and on numerous Reclamation projects.

The method uses a developed surface created by "unrolling" or "flattening out" the circumference of the tunnel or shaft to form a "plan" of the entire wall surface (figure 6-7). The geologic features are plotted on this plan. The method is especially effective in that geologic features of all types can be plotted directly onto the map regardless of orientation or location with no projection required. The method is useful for plotting curving or irregular discontinuities which are difficult to project to a flat plane as in other methods.

**Procedure.**—Full periphery mapping generally requires the assembly of field sheets prior to the actual start of mapping. This is done for drifts and tunnels by first drawing in the crown centerline of the plan (figure 6-7). The bases of the walls or the invert are then plotted at a circumferential distance from the crown centerline on the plan. For instance, if the tunnel is 10 feet (3.048 m) in excavated diameter, the invert centerline will be plotted 15.71 feet (4.79 m) (in scale) from the crown centerline. Plot springline at the appropriate circumferential

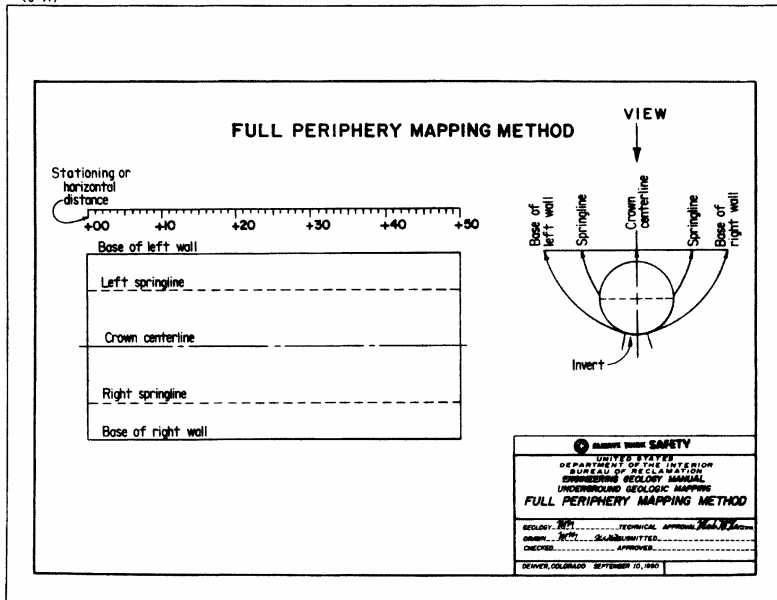


Figure 6-7.--Full periphery mapping method layout.

## MAPPING

distance from the crown centerline. This process is done for both walls and produces a plan which represents the actual wall surface of the excavation. The map layout is designed to be viewed from above the tunnel. Shaft data are plotted as viewed from inside the excavation. The tunnel invert is not mapped because rock surfaces usually are covered with muck or invert segments. Plot scales on either side of the plan to provide distance control while mapping. A longitudinal section view of the excavation may be added alongside the plan to provide a space to record types and locations of support, overbreak, etc. Plot geologic features on the field sheets (figures 6-4 and 6-5) by noting where the features intercept known lines, such as where a particular joint intercepts the crown centerline, the spring line on both walls, or the base of either wall. The trace of the joint is sketched to scale between these known points. The strike and dip of the discontinuity are recorded directly on the field sheet adjacent to the trace. The locations of samples, photographs, water seeps, and flows are plotted on the map (figure 6-8).

The Brunton compass is used to measure dips on the various discontinuities; but due to the presence of support steel, rock bolts, utilities, and any natural magnetism of the wall rock, a Brunton may not be reliable for determining the strike of the feature. In this case, the strike may be determined by one of several methods. The first method is to align the map parallel to the tunnel where the feature is exposed in the wall and plot the strike by eye on the sheet parallel to the strike of the feature in the wall. The second method is to observe the strike of the feature on the map where it intersects the crown centerline. At this point, the crown is essentially horizontal, and the trace of the feature at this point represents the strike. The third method is slightly more complex but is the most accurate method of the three.

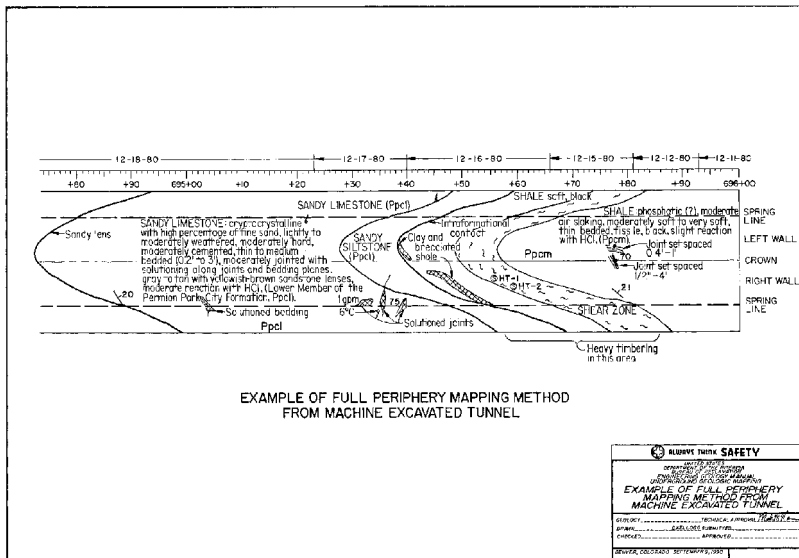


Figure 6-8.—Full periphery geologic map example.

## MAPPING

This method requires locating where the feature intersects springline on each wall of the full periphery map. These points are projected to the corrected springline. A line drawn between the projected points represents the strike of the feature. Note that these methods assume that the tunnel or drift is relatively horizontal. In some cases, if the excavation is inclined, the apparent strike can be corrected for the amount of inclination. A fourth method is to use a gyroscopic compass.

**Other Applications.**—With minor variations in the method described above, the full periphery method can be used equally well in vertical or inclined shafts, horseshoe shaped drifts and tunnels, and other regular shaped excavations.

**Advantages.**—The full periphery method:

- Involves plotting the actual traces of geologic features as they are exposed in the tunnel. This eliminates the distortion and interpretation introduced by other methods where the traces are projected back to a plane tangent to the tunnel.
- Allows the geologist to observe and plot irregularities in geologic features and make accurate three-dimensional interpretations of the features.
- Allows rapid and easy plotting of the locations of samples and photographs.
- Allows easy and rapid recording of the locations of rock bolts and other types of rock reinforcement.

### **Disadvantages.—**

- Since the surface of the excavation is generally a curved surface, the trace of planar features, such as fractures, faults, and bedding planes, produce curves when plotted on the map.
- The full periphery method requires that the points at which features intersect springline be projected to the original tunnel diameter in order to compute the true strike of the discontinuity (figure 6-7).

### **Plan and Section**

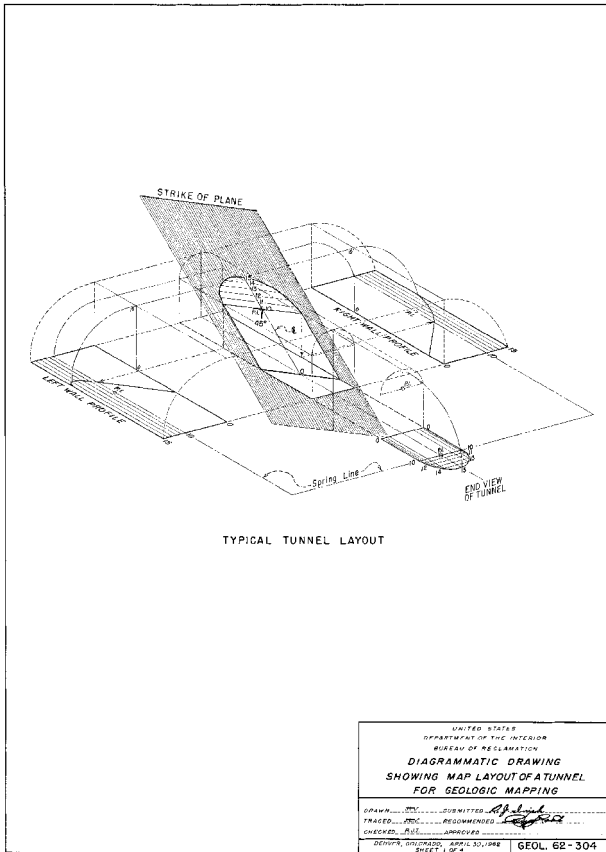
The plan and section method has been used in engineering practice but has generally been replaced by the full periphery mapping method. The plan and section method is still used where data interpretation is facilitated by the flat plan and sections. The method creates vertical sections commonly coincident with a wall or walls of a tunnel or shaft, through centerline, or is tangent to a curving surface commonly at springline or an edge of a shaft (figure 6-9). Geologic features are projected to the sections and plotted as they are mapped.

The method produces a map which is a combination of direct trace and projection or a projection of the walls except where the map is tangent to the excavation (figure 6-10). The plan through tunnel springline and centerline or shaft centerline is a projection of the geologic features exposed in the excavation.

**Procedure.**—The plan and section method generally requires the assembly of field sheets prior to the actual start of mapping. This is done for drifts and tunnels by drawing vertical sections the height of the excavation.

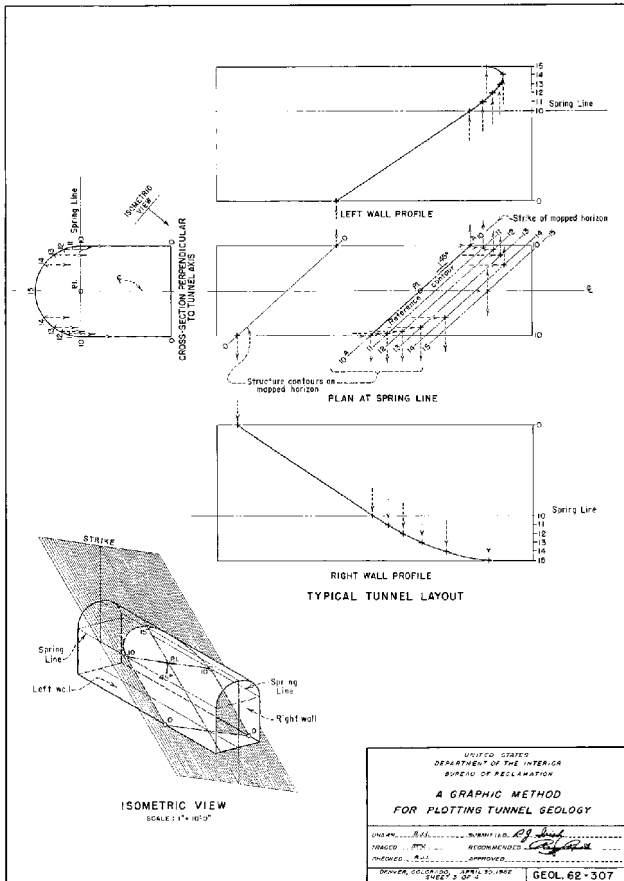


# MAPPING



**Figure 6-9.—Map layout of a tunnel for geologic mapping.**

# FIELD MANUAL



**Figure 6-10.—Relationship of planar feature trace to map projections.**

## MAPPING

The bases of the walls or the invert form the base of the section with springline plotted and the crown forming the top of the section. For instance, if the tunnel is 20 feet (6 m) high, the crown will be 20 feet (6 m) from the invert. Springline is plotted the appropriate vertical distance from the crown or invert (figure 6-10). This process may be done for one or both walls, producing one or two vertical representations of the wall/arch exposure. Shafts are similar, but the section corresponds to the wall of a rectangular shaft or is tangent to the shaft wall at a point, and the map is a projection of the shaft of one diameter.

A section through tunnel springlines produces a plan projection of the arch except at the plan intersection with the wall at springline. The corresponding section through a shaft produces a vertical projection of the wall(s) through a shaft or along a diameter. The map represents the actual wall surface of the excavation only where the projection intersects the wall.

Scales are added on either side of the sections to provide distance control while plotting. An additional longitudinal section view of the excavation may be added to provide a space to record types and locations of support or overbreak. Geologic features are then plotted on the field sheets by noting where the features intercept known lines, such as where a particular joint intercepts the crown centerline, the spring line on both walls, or the base of either wall. The trace of the joint is then projected to the section between these known points. The attitudes of features are recorded on the field sheet adjacent to the trace. The location of samples, photographs, water seeps, and flows can be recorded by finding their location on the wall and projecting that location to the map.

## FIELD MANUAL

**Advantages.**—The plan and section method:

- Produces two-dimensional sections and plans that do not require conversion. The sections and plans can be integrated directly with other plans and sections. The sections and plans are easily understood by individuals not familiar with full periphery mapping or individuals who have difficulty visualizing structural features in three-dimensions.
- Permits direct determination of strikes by spring-line intersections.

**Disadvantages.**—Since the surface of the excavation is generally a curved surface, the trace of planar features, such as fractures, faults, and bedding planes, are projections to a plane. The only objective data is where the map is coincident or tangent to the excavation surface.

The plan and section method requires:

- Plotting and observing geologic features and making accurate three-dimensional interpretations of the features by projecting locations to a plane.
- Plotting locations of samples and photographs by projection.
- Recording locations of rock bolts and other types of rock reinforcement by projection.
- Plotting is done after data collection and re-examination of the site is difficult or not practical.

## MAPPING

### **Face Maps**

The geology exposed in an excavation face is plotted directly on a map. The purpose of the face map is to provide a quick appraisal of rock conditions and provide data for special detailed studies. The combination of wall and face maps will usually give an adequate and clear permanent record of any complex tunnel geology. Natural scales such as 1 inch = 1 to 2 feet (1:50) are the most satisfactory. All significant geologic features which may affect the stability of the tunnel must be mapped.

### **Photogrammetric Mapping**

Photogrammetric geologic mapping is a specialized method consisting of the interpretation of close-range stereophotography of excavation walls. Photogrammetric control is provided by surveyed targets or by a gnomon or scale in the photographs. The stereophotos are interpreted using photogrammetric software or an analytical plotter. Feature location accuracy can vary from a few inches (cm) to one-eighth of an inch (3mm) depending on equipment and survey control accuracy. The photogrammetric mapping can be combined with detail line surveys for small-scale data collection and control.

### **Exploration Mapping Method Selection**

The geologic mapping format for exploratory drifts and shafts should be determined by data uses. Direct integration of excavation maps into composite maps of a dam foundation is much easier if undistorted sections are available. The maps can be treated in the same manner as drill hole logs. The disadvantages of plan and section mapping may be offset by the advantages of easy interpretation and integration into other data bases.

## FIELD MANUAL

**Construction Mapping.**—Full periphery geologic mapping should be used for routine construction activities. The advantages of increased speed and accuracy in production mapping and the reduction of interpretation offsets the disadvantages.

### **Summary**

This guide to tunnel geologic mapping during construction has been developed for general use and serves to standardize procedures and data collection. Items of primary significance are included, but some are not adaptable to all tunnels or methods of tunnel excavation. The judgment of an experienced geologist is the best guide to the specific items and amount of detail required to provide pertinent, informative data. To ensure reliable and useful tunnel geologic studies, all important geology and related engineering construction data which may be significant to tunnel construction as well as in the planning, designing, and constructing of future tunnels should be considered for inclusion in the tunnel map and report.

## **Photogeologic Mapping**

### **General**

Aerial photographs generally are used in reconnaissance geologic mapping, geologic field mapping, and in generation of photo-interpretive geologic maps. Various scales of airphotos are valuable for regional and site studies, for both detection and mapping of a wide variety of geologic features important to engineering geology.

## MAPPING

### **Types of Aerial Photographs**

**Panchromatic (Black and White).**—Panchromatic photography records images essentially across the entire visible spectrum, and with proper film and filters also can record into the near-infrared. In aerial photography, blue is generally filtered out to reduce the effects of atmospheric haze.

**Natural Color.**—Images are recorded in the natural colors seen by the human eye in the visible portion of the spectrum.

**False-Color Infrared.**—Images are recorded using part of the visible spectrum and part of the near-infrared, but the colors in the resultant photographs are not natural (false-color). Infrared film is commonly used and is less affected by haze than other types. False-color photography is not the same as thermal-infrared imaging which uses the thermal part of the infrared spectrum.

**Multispectral.**—Photographs acquired by multiple cameras simultaneously recording different portions of the spectrum can aid interpretation.

### **Photogrammetry and Equipment**

Use stereoscopes to view aerial photographs for maximum utility and ease of interpretation. Pocket stereoscopes are useful in the field or office. Large mirror stereoscopes are useful for viewing large quantities of photos or photos in rolls. Know the photo scale, resolution, and exaggeration. Be aware of the types of distortions inherent in airphotos.

## FIELD MANUAL

### **Compilation of Photogeologic Map Data**

Mapping should be done on transparent one-side-matte mylar overlays and not on the photographs. Any lines, even if erased, can confuse later interpretations using the photos. The mapping is then transferred to base maps minimizing the effects of distortions in photos due to the camera optics. Orthophoto quadrangles can help reduce this distortion.

### **Analysis of Aerial Photographs**

#### **General Interpretive Factors**

Analysis of aerial photographs involves interpreting indirect data. In most cases, several factors are used to interpret geologic conditions. Interpretive factors usually used in the analysis of aerial photographs are:

**Sun Angle.**—High or low illumination angles may be desired, depending on the nature of the features to be detected.

**Photographic Tone.**—Variations in color, intensity, shade and shadows.

**Texture.**—Frequency of change in tone, evident as roughness, smoothness.

**Color.**—True and false-color imagery may be easier to interpret than panchromatic photographs, depending on features being observed. For some applications (e.g., low sun angle photography), panchromatic photography is better.



## MAPPING

**Geomorphic Shape and Pattern.**—Geologic conditions can be identified by mapping various types of geomorphic features related to drainage, bedding, and structure.

**Vegetation.**—Some types of vegetation and vegetal patterns can assist in interpreting geology. Vegetation may indicate depth of soil, type of soil, available moisture, and type of bedrock.

### **Photoanalysis for Reconnaissance Geologic Mapping**

Photo-reconnaissance geologic mapping can be done to produce a preliminary geologic map of the study area prior to going into the field to check and verify the interpreted geologic data or to produce a finished geologic map with little or no field checking. These maps are called photo-reconnaissance geologic maps and photo-interpretive geologic maps, respectively.

#### **Photo-Reconnaissance Geologic Mapping**

Photo-analysis prior to field work allows the mapper to form a preliminary concept of the geology of the study area and to select areas for detailed examination. Prior photo-analysis is critical if available field time is limited, especially when a large area is involved, as in regional studies, reservoir area mapping, and pipeline or canal alignment studies.

#### **Photo-Interpretive Geologic Mapping**

Geologic maps produced solely from aerial photographs with little or no field checking are useful when time, funds, or access are limited or when adverse weather prevents a more detailed field mapping program. The

## FIELD MANUAL

limitations of this form of geologic map are dependent on outcrop density and degree of exposure, amount of vegetative cover, contrast of the geologic units, and the skills of the photogeologic mapper. This type of map is useful for preliminary or reconnaissance level evaluations but should never be used for design level work.

### **Photoanalysis During Geologic Field Mapping**

The location and verification of geologic features in the field can usually be expedited by using aerial photographs. Photographs often reveal landforms that are difficult to see or interpret from the ground, such as land-slides. Photographs can be used to clarify and speed up field mapping by allowing a comprehensive view of the study site and the relationships of the various geologic features exposed. Alternately viewing photos and examining outcrops can greatly facilitate mapping.

### **Availability of Imagery**

Aerial photography is available, commonly in a variety of scales and types, for essentially the entire conterminous United States. The principal repositories of publicly owned airphotos is the EROS Data Center, operated by the U.S. Geological Survey and the Agricultural Stabilization and Conservation Service (ASCS) of the U.S. Department of Agriculture. The USGS has several regional offices of the Earth Science Information Center (ESIC). The ESIC operates the Aerial Photography Summary Record System (APSRs), which is a standard reference data base for users of aerial photographs. The APSRS lists aerial photography available from a large number of government agencies and commercial companies. The lists are comprehensive and categorized by state and by latitude and longitude. APSRS data are

## MAPPING

available on request from ESIC. ESIC also provides information about cartographic products other than imagery.

Some important addresses and telephone numbers are:

USDA-ASCS (801) 524-5856  
Aerial Photography Field Office  
Customer Services  
2222 West 2300 South  
P.O. Box 30010  
Salt Lake City, UT 84130-0010

USGS (605) 594-6151  
EROS Data Center  
Sioux Falls, SD 57198

USGS (303) 202-4200  
ESIC  
Denver Federal Center  
Denver, CO 80225

USGS (650) 329-4309  
ESIC  
345 Middlefield Road  
Menlo Park, CA 94025

### **Aerial Photography Flight Planning**

If air photos are not available at the right scale, or of the right type for an area, specific flights can be made. Successful airphoto mission planning requires consideration of several factors, including film type, scale, time of day (sun-angle), time of year, and the size of the area to be covered. Mission planning should not be done by someone unfamiliar with the process without assistance. Specifications should be written to ensure that the resulting photographs will be appropriate for the

## FIELD MANUAL

intended purpose. Information critical to mission planning is available from the references listed below.

### **Time and Cost Estimating**

The cost of data acquisition is relatively easy to estimate. The cost of interpretation is much harder to estimate, being a function of the time required, which is related to the size and complexity of the study area and the skill of the interpreter. The cost of a single drill hole will pay for a lot of aerial photography and interpretation.

### **References**

A classic text on the use of airphotos in geology was reprinted in 1985 and should be readily available. Some of the equipment described is obsolete and it is essentially limited to discussion of panchromatic photography. The publication contains numerous stereopairs with geologic descriptions and is one of the best works on airphoto interpretation for geologists:

Ray, R.G., *Aerial photographs in geologic interpretation and mapping*, USGS Professional Paper 373, 230 p., 1960.

Other useful references are:

Lattman, L.H., and Ray, R.G., *Aerial photographs in field geology*, Holt, Rinehart and Winston, New York, NY 221 p., 1965.

Miller, V.C., *Photogeology*, McGraw-Hill, New York, NY, 248 p., 1961.

## MAPPING

A reference containing no general discussion of principles, but with excellent examples of stereopairs of geologic features, associated topographic maps, and geologic annotations is:

Scovel, J.L., et al., *Atlas of Landforms*, Wiley & Sons, New York, NY, 164 p., 1965.

A broad and lengthy reference covering remote sensing in general, including much information about aerial photography of all types, is:

Colwell, R.N., editor, *Manual of remote sensing*, 2nd edition, American Society of Photogrammetry, Falls Church, VA, 272 p., 1983.

## BIBLIOGRAPHY

- [1] U.S. Geological Survey, *Map Projections - A Working Manual*, U.S. Geological Survey Professional Paper 1395, 1987.
- [2] Jackson, Julia A., editor, *The Glossary of Geology*, 4th edition, American Geologic Institute, Alexandria, VA, 1997.
- [3] Lahee, Frederic H., *Field Geology*, 6th edition, McGraw-Hill, Inc., New York, NY, 1961.
- [4] Compton, Robert R., *Geology in the Field*, John Wiley and Sons, New York, NY, 1985.
- [5] Bureau of Reclamation, Division of Safety, *Safety and Health Standards*, Denver Office, Denver, CO.

## FIELD MANUAL

- [6] Proctor, M.E., and White, T.L., *Rock Tunneling with Steel Supports*, Commercial Shearing, Inc., Youngstown, OH, 1977.
- [7] Hatheway, A.W., "Trench, Shaft, and Tunnel Mapping," *Bulletin of the Association of Engineering Geologists*, v. XIX, 1982.
- [8] U.S. Army Corps of Engineers, "Engineering and Design, Geologic Mapping of Tunnels and Shafts by the Full Periphery Method," *Engineer Technical Letter No. 1110-1-37*, Washington, DC, 1970.
- [9] Proctor, R.J., "Mapping Geological Conditions in Tunnels," *Bulletin of the Association of Engineering Geologists*, v. VIII, 1971.

## Chapter 7

# DISCONTINUITY SURVEYS

### General

Physical properties of discontinuities generally control the engineering characteristics of a rock mass. Accurate and thorough description of discontinuities is an integral part of geological mapping conducted for design and construction of civil structures. It is improbable that any survey will provide complete information on all the discontinuities at a site. However, properly conducted surveys will furnish data with a high probability of accurately representing the site discontinuities. This chapter discusses discontinuity recording methodology. These recording methods can be applied to outcrops, drill holes, open excavations, and the perimeters of underground openings. The evaluation of discontinuity data is well described in the literature. For example, plotting discontinuity data on stereograms, contouring to determine prominent orientations, and subsequent wedge analyses are described in *Rock Slope Engineering* [1] and *Methods of Geological Engineering in Discontinuous Rock* and *Introduction to Rock Mechanics* [2,3]. Chapter 5, Terminology and Descriptions for Discontinuities, lists data that are typically recorded in discontinuity surveys.

It is extremely important that the actual discontinuity descriptors and measurement units be selected to support the anticipated rock mass classification system(s). Acquiring incomplete or excessive data may limit data usefulness in subsequent analyses, and result in excessive costs due to repeating surveys or from collecting more data than needed.

## FIELD MANUAL

### Empirical Methods for Rock Mass Classification

A number of empirical methods have been developed to predict the stability of rock slopes and underground openings in rock and to determine the support requirements of such features. A method for estimating steel-arch support requirements in tunnels was one of the first [4], and various methods which address open-cut excavations and existing rock slopes have been used since. The Geomechanical Classification (Rock Mass Rating [RMR]) [5,6] and the Norwegian Geotechnical Institute (NGI) (Q-system Classification [Q]) [7] are commonly used. Both of these methods incorporate Rock Quality Designation (RQD) [8]. Since both the RMR and Q-system are based on actual case histories, both systems can be somewhat dynamic, and refinements based on new data are widely suggested. Additional information on RQD, RMR, and the Q-system is provided in chapter 2.

Other predictive methods include the Rock Structure Rating (RSR) [9] and the Unified Rock Classification System (URCS) [10]. Keyblock analysis [11,12] is a means of determining the most critical or key blocks of rock formed by an excavation in jointed, competent rock. An excellent single source of information on the various classification systems is in American Society for Testing Materials Special Technical Publication 984, *Rock Classification Systems for Engineering Purposes*.

### Data Collection

Discontinuity data can be collected using areal or detail line survey methods. The areal method, which consists of the spot recording of discontinuities in outcrops within an area of interest, is of limited use in geotechnical analyses. Areal surveys should be applied only for preliminary scoping of a site or in cases where the lateral



## DISCONTINUITY SURVEYS

extent of exposed rock is inadequate to perform detail line surveys. The detail line survey (DLS) method (DLS or line mapping) provides spacial control necessary to accurately portray and analyze site discontinuities. DLS mapping was originally a method of mapping road cuts and open pit excavations. DLS use has been expanded both in scope and types of exposures mapped. Each geologic feature that intercepts a usually linear traverse is recorded. The traverse can be a 100-ft (30 m) tape placed across an outcrop, the wall of a tunnel, a shaft wall at a fixed elevation, or an oriented drill core. In all cases, the alignment of the traverse and the location of both ends of the traverse should be determined. The mapper moves along the line and records everything, as noted in chapter 5, or as needed to support analyses. Feature locations are projected along strike to the tape, and the distance is recorded. Regardless of the survey method, the mapper must obtain a statistically significant number of observations. A minimum of 60 discontinuity measurements per rock type is suggested for confidence in subsequent analyses [14].

The orientation of a discontinuity can be recorded either as a strike azimuth and dip magnitude, preferably using the right-hand rule, or as a dip azimuth and magnitude (eliminating the need for dip direction and alpha characters required by the quadrant system). According to the right-hand rule, the strike azimuth is always to the left of the dip direction. When the thumb of the right hand is pointed in the strike direction, the fingers point in the dip direction. The selected recording method should be used consistently throughout the survey.

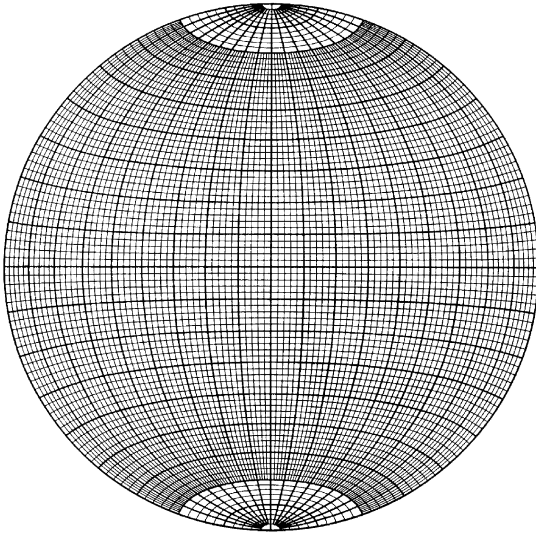
Data acquired in a single straight-line survey are inherently biased. The more nearly the strike of a discontinuity parallels the path of a line survey, the less frequently discontinuities with that strike will be

## FIELD MANUAL

recorded in the survey. This is called *line bias*. The number of intersecting discontinuities is proportional to the sine of the angle of intersection. In order to compensate for line bias, a sufficient number of line surveys at a sufficient variety of orientations should be conducted to ensure that discontinuities of any orientation are intersected by at least one survey at an angle of at least 30 degrees. Common practice is to perform two surveys at nearly right angles or three surveys at radial angles of 120 degrees. True discontinuity (set) spacing and trace lengths can be obtained by correcting the bias produced by line surveys [15, 16].

All discontinuities should be recorded regardless of subtlety, continuity, or other property until determined otherwise. Data collection should be as systematic as practicable, and accessible or easily measurable discontinuities should not be preferentially measured. Consistency and completeness of descriptions are also important. Consistency and completeness are best maintained if all measurements are taken by the same mapper and data are recorded on a form that prompts the mapper for the necessary descriptors. A form minimizes the probability of descriptor omission and facilitates plotting on an equal area projection, commonly the Schmidt net (figure 7-1), or entering data for subsequent analysis. Computer programs are available that plot discontinuities in a variety of projections and perform a variety of analyses. Whether the plot format is the equal area projection (Schmidt net) or equal angle projection (Wulff net), evaluation of the plotted data requires an understanding of the method of data collection, form of presentation, and any data bias corrections. References 2 and 3 in the bibliography are good sources of data analysis background information.

## DISCONTINUITY SURVEYS



**Figure 7-1. Equatorial equal area net (Schmidt net).**

Different rock types in the same structural terrain can have different discontinuity properties and patterns, and the host rock for each discontinuity should be recorded. This could be an important factor for understanding subsequent evaluations of tunneling conditions, rock slopes, or the in-place stress field in underground openings.

Figure 7-2 is a form that can be used to record the data in an abbreviated or coded format. Recording these data will provide the necessary information for determining RMR and Q. These codes are derived from the descriptors for discontinuities presented in chapter 5.

Project: _____											<b>DISCONTINUITY LOG</b>											Sheet _____ of _____																																																																																												
Feature: _____											Location: _____											Date: _____																																																																																												
Feature: _____											Location: _____											Recorded by: _____																																																																																												
Traverse Id.	Northing (start)	Easting (start)		Elevation (start)	Trend	Plunge		Traverse Length		Fl. No.		Recording Method: Strike Azimuth and Dip Magnitude * Dip Azimuth and Dip Magnitude																																																																																																						
Number	Distance	Rock	Azimuth	Dip	C	E	R	M	H	W	O	T	HL	Notes and Comments																																																																																																				
														<table border="0"> <tr> <td>Continuity</td> <td>C1 &lt;3 ft. (&lt;1 m)</td> <td>M1 Dry, not possible</td> <td>W1 Fresh</td> <td>T0 None</td> </tr> <tr> <td></td> <td>C2 3-10 ft. (1-3 m)</td> <td>M2 Dry, no evidence</td> <td>W2 Slightly weathered to fresh</td> <td>T1 &lt;0.003 ft (&lt;1 mm)</td> </tr> <tr> <td></td> <td>C3 10-30 ft. (3-10 m)</td> <td>M3 Dry, some evidence</td> <td>W3 Slightly weathered</td> <td>T2 0.003-0.01 ft (1-3 mm)</td> </tr> <tr> <td></td> <td>C4 30-100 ft. (10-30 m)</td> <td>M4 Damp, no free water</td> <td>W4 Moderately to slightly weathered</td> <td>T3 0.01-0.03 ft (3-10 mm)</td> </tr> <tr> <td></td> <td>C5 &gt;100 ft. (&gt;30 m)</td> <td>M5 Wet, some drips</td> <td>W5 Moderately weathered</td> <td>T4 0.03-0.1 ft (10-30 mm)</td> </tr> <tr> <td></td> <td></td> <td>M6 Cont. flow, low pres.</td> <td>W6 Intensely to moderately weathered</td> <td>T5 &gt;0.1 ft (&gt;30 mm)</td> </tr> <tr> <td>Ends</td> <td>E0 No ends visible</td> <td>M7 Cont. flow, high pres.</td> <td>W7 Intense, weathered</td> <td>HLD Completely, to strength of wall rock</td> </tr> <tr> <td></td> <td>E1 One end visible</td> <td></td> <td>W8 Very intensely weathered</td> <td>HL2 &gt;50%, or weaker than wall rock</td> </tr> <tr> <td></td> <td>E2 Both ends visible</td> <td>H1 Extremely hard</td> <td>W9 Decomposed</td> <td>HL3 &lt;50%</td> </tr> <tr> <td></td> <td></td> <td>H2 Very hard</td> <td></td> <td>HL5 No induction</td> </tr> <tr> <td></td> <td></td> <td>H3 Hard</td> <td>O0 Tight</td> <td></td> </tr> <tr> <td></td> <td></td> <td>H4 Moderately hard</td> <td>O1 &lt;0.003 ft (&lt;1 mm)</td> <td></td> </tr> <tr> <td>Roughness</td> <td>R1 Stepped</td> <td>Openness</td> <td>O2 0.003-0.01 ft (1-3 mm)</td> <td>* Dip magnitude follows right-hand rule</td> </tr> <tr> <td></td> <td>R2 Rough</td> <td></td> <td>O3 0.01-0.03 ft (3-10 mm)</td> <td></td> </tr> <tr> <td></td> <td>R3 Moderately rough</td> <td></td> <td>O4 0.03-0.1 ft (10-30 mm)</td> <td></td> </tr> <tr> <td></td> <td>R4 Slightly rough</td> <td></td> <td>O5 &gt;0.1 ft (&gt;30 mm)</td> <td></td> </tr> <tr> <td></td> <td>R5 Smooth</td> <td></td> <td></td> <td></td> </tr> <tr> <td></td> <td>R6 Polished</td> <td></td> <td></td> <td></td> </tr> </table>											Continuity	C1 <3 ft. (<1 m)	M1 Dry, not possible	W1 Fresh	T0 None		C2 3-10 ft. (1-3 m)	M2 Dry, no evidence	W2 Slightly weathered to fresh	T1 <0.003 ft (<1 mm)		C3 10-30 ft. (3-10 m)	M3 Dry, some evidence	W3 Slightly weathered	T2 0.003-0.01 ft (1-3 mm)		C4 30-100 ft. (10-30 m)	M4 Damp, no free water	W4 Moderately to slightly weathered	T3 0.01-0.03 ft (3-10 mm)		C5 >100 ft. (>30 m)	M5 Wet, some drips	W5 Moderately weathered	T4 0.03-0.1 ft (10-30 mm)			M6 Cont. flow, low pres.	W6 Intensely to moderately weathered	T5 >0.1 ft (>30 mm)	Ends	E0 No ends visible	M7 Cont. flow, high pres.	W7 Intense, weathered	HLD Completely, to strength of wall rock		E1 One end visible		W8 Very intensely weathered	HL2 >50%, or weaker than wall rock		E2 Both ends visible	H1 Extremely hard	W9 Decomposed	HL3 <50%			H2 Very hard		HL5 No induction			H3 Hard	O0 Tight				H4 Moderately hard	O1 <0.003 ft (<1 mm)		Roughness	R1 Stepped	Openness	O2 0.003-0.01 ft (1-3 mm)	* Dip magnitude follows right-hand rule		R2 Rough		O3 0.01-0.03 ft (3-10 mm)			R3 Moderately rough		O4 0.03-0.1 ft (10-30 mm)			R4 Slightly rough		O5 >0.1 ft (>30 mm)			R5 Smooth					R6 Polished			
Continuity	C1 <3 ft. (<1 m)	M1 Dry, not possible	W1 Fresh	T0 None																																																																																																														
	C2 3-10 ft. (1-3 m)	M2 Dry, no evidence	W2 Slightly weathered to fresh	T1 <0.003 ft (<1 mm)																																																																																																														
	C3 10-30 ft. (3-10 m)	M3 Dry, some evidence	W3 Slightly weathered	T2 0.003-0.01 ft (1-3 mm)																																																																																																														
	C4 30-100 ft. (10-30 m)	M4 Damp, no free water	W4 Moderately to slightly weathered	T3 0.01-0.03 ft (3-10 mm)																																																																																																														
	C5 >100 ft. (>30 m)	M5 Wet, some drips	W5 Moderately weathered	T4 0.03-0.1 ft (10-30 mm)																																																																																																														
		M6 Cont. flow, low pres.	W6 Intensely to moderately weathered	T5 >0.1 ft (>30 mm)																																																																																																														
Ends	E0 No ends visible	M7 Cont. flow, high pres.	W7 Intense, weathered	HLD Completely, to strength of wall rock																																																																																																														
	E1 One end visible		W8 Very intensely weathered	HL2 >50%, or weaker than wall rock																																																																																																														
	E2 Both ends visible	H1 Extremely hard	W9 Decomposed	HL3 <50%																																																																																																														
		H2 Very hard		HL5 No induction																																																																																																														
		H3 Hard	O0 Tight																																																																																																															
		H4 Moderately hard	O1 <0.003 ft (<1 mm)																																																																																																															
Roughness	R1 Stepped	Openness	O2 0.003-0.01 ft (1-3 mm)	* Dip magnitude follows right-hand rule																																																																																																														
	R2 Rough		O3 0.01-0.03 ft (3-10 mm)																																																																																																															
	R3 Moderately rough		O4 0.03-0.1 ft (10-30 mm)																																																																																																															
	R4 Slightly rough		O5 >0.1 ft (>30 mm)																																																																																																															
	R5 Smooth																																																																																																																	
	R6 Polished																																																																																																																	

Discontinuity Log 14HL  
Version 1.0

Figure 7-2. Discontinuity log field sheet.

## DISCONTINUITY SURVEYS

### BIBLIOGRAPHY

- [1] Hoek, E., and J. Bray, *Rock Slope Engineering*, revised 3rd edition, The Institute of Mining, London, 1981.
- [2] Goodman, R.L., *Methods of Geological Engineering in Discontinuous Rock*, 1976.
- [3] Goodman, R.L., *Introduction to Rock Mechanics*, 1980.
- [4] Terzaghi, K., Rock defects and loads on tunnel support, *Rock Tunneling with Steel Supports*, Commercial Shearing, Inc., Youngstown, OH, 1946.
- [5] Bieniawski, Z.T., *Engineering Rock Mass Classifications*, 1989.
- [6] Bieniawski, Z.T., and C.M. Orr, Rapid site appraisal for dam foundations by the geomechanics classification, *Proceedings 12th Congress Large Dams*, ICOLD, Mexico City, pp. 483-501, 1976.
- [7] Barton, N., F. Lien, and J. Lunde, Engineering classification of rock masses for the design of tunnel support, *Rock Mechanics*, v. 6, No. 4, pp. 189-236, 1974.
- [8] Deere, D.U., A.J. Hendron, F.D. Patton, and E.J. Cording, Design of surface and near surface construction in rock, *Proceedings 8th U.S. Symposium Rock Mechanics*, AIME, New York, pp. 237-302, 1967.
- [9] Wickham, G.E., and H.R. Tiedemann, Ground support prediction model RSR concept, *Proceedings Rapid Excavation Tunneling Conference*, AIME, New York, pp. 691-707, 1974.

## FIELD MANUAL

[10] Williamson, D.A., Unified rock classification system, *Bulletin of the Association of Engineering Geologists*, v. XXI, No. 3, pp. 345-354, 1984.

[11] Goodman, R.E., and Gen-Hua Shi, Geology and rock slope stability application of a keyblock concept for rock slopes, *Proceedings 3rd International Conference on Stability in Open Pit Mining*, Vancouver, June 1981.

[12] Goodman, R.E., and Gen-Hua Shi, *Block Theory and Its Application to Rock Engineering*, 1985.

[13] Piteau, D., Geological factors significant to the stability of the slopes cut in rock, *Proceedings of the Open Pit Mining Symposium*, South African Institute of Mining and Metallurgy, September 1970.

[14] Savely, J., Orientation and Engineering Properties of Joints in Sierrita Pit, Arizona, MS thesis, University of Arizona, 1972.

[15] Priest, S.D., and J.A. Hudson., Estimation of discontinuity spacing and trace length using scanline surveys, *International Journal of Rock Mechanics-Mining Sciences and Geomechanics Abstracts*, v. 18, No. 3, pp. 183-197, 1981.

[16] Terzaghi, R.D., Sources of error in joint surveys, *Geotechnique*, v. 15, No. 3, pp. 287-304, 1965.

## Chapter 8

# EXPLORATION DRILLING PROGRAMS

### Introduction

This chapter is a guide for developing effective and efficient exploration drilling programs. Drilling programs that involve extensive soil sampling, rock coring, instrumentation installations, or in-place testing commonly have excessive cost overruns and late completion times. The effort put into developing a well organized drilling program that explicitly defines drilling and sampling requirements can lower exploration costs significantly by eliminating unnecessary or redundant work and meeting schedules. Good references on drilling methods and equipment are *Groundwater and Wells*, second edition, by Fletcher G. Driscoll, published by Johnson Division, St. Paul, Minnesota 55112, and *Drilling: The Manual of Methods, Applications, and Management*, CRC Lewis Publishers, Boca Raton, Florida, 1996.

### Planning the Exploration Drilling Program

Developing an exploration program requires a thorough knowledge of the design requirements, site conditions, drilling equipment requirements and capabilities, and soil or rock core testing. It is extremely important that exploration needs be identified to avoid overdesign of a program by too many "it would be nice" requests.

A complete and detailed description of the drill site location, accessibility, work requirements, geology, and other pertinent information should be made available to either the drilling contractor or in-house drilling staff. This information is necessary for an effective and efficient drilling operation that will accomplish the program objectives. A major objective is to obtain the most information and samples possible from each hole by

## FIELD MANUAL

optimizing location, drilling and sampling methods, depth, and completion. For example, a drill hole on the intersection of dam and outlet works centerlines drilled to the depth of the deepest data requirement and sampled for both structures provides data for both structures.

Most exploration is done in phases, with subsequent exploration designed to refine the understanding of a site. Drill holes should be logged as the holes are drilled, so hole depths and subsequent hole locations can be changed as exploration progresses. Because an exploration program evolves as data are acquired, information should be reviewed and added to maps and sections as the data become available.

### **Site Inspection**

An onsite inspection of the drilling location should be made by the geologist, designers, and other essential members of the exploration team. The purpose of the onsite inspection is to determine the exploration needed to provide the data required for design. Data are required for several design disciplines with different needs. Having knowledgeable representatives see the site is important when formulating an exploration program. Changes and additions to exploration programs during or after exploration are expected but can be minimized with careful planning.

During the site inspection, the geologist and designers should discuss in detail all the design concerns that can only be solved by analyzing the subsurface geology. The team should be explicit as to the size, quantity, type, and quality of soil or rock samples that are necessary to develop an accurate evaluation of geologic conditions. The geologist can recommend the type of equipment and



## DRILLING PROGRAMS

drilling procedures needed, based on the drilling and sampling requirements, and to address design concerns as well as to provide samples needed for laboratory testing.

The onsite inspection should provide other pertinent information which is critical to the selection of specific equipment. The following factors should be addressed when preparing the exploration plan.

**Topography-drill site accessibility.**—The type of drilling equipment most suitable for the work needs to be determined. Truck-mounted, all-terrain, skid-mounted, or a combination of several types may be appropriate. Heavy excavation and hauling equipment may be required to construct access roads, drill pads, stream crossings, temporary bridges, or pipe culverts for river crossings. Explosives and track drills may be required to prepare drill pads or remove unsafe rock overhangs from drill sites, and roadbase or rockfill may have to be placed over soft mud or swamp. Helicopter support may be needed for fly-in rigs and heavy timber clearing. A source of water for drilling needs to be identified. Other considerations are whether there is a relatively close and level area that may be used as a temporary drill yard/staging area and how close equipment can be safely driven into the drill area.

**Right-of-way, access permits, drilling permits, construction or clearing permits.**—The drilling locations, whether on public or private land, may require access permits. Several different types of permits may be needed, including archeological and environmental permits. These permits may take considerable time to obtain and should be acquired as soon as possible. The limitations of the permits should be determined. Construction or clearing permits may be needed. Most

## FIELD MANUAL

states require special licenses or permits for drill operators who perform water-well drilling and installation.

### **Protection of the Environment**

Environmental, archeological, and biological factors may place restrictions or conditions on a site. Disposal of the cleared material should be arranged. The use of drilling mud requires planning and implementation prior to drilling. If the drill mud circulation pits can be excavated, the mud pits may have to be enclosed with fencing to keep out animals. Drill mud and cuttings as well as fuel and oil spills or oil change residue will require disposal. Some drill mud, cuttings, and water should be stored because the material is considered a hazardous waste. These materials may have to be disposed of at approved sites. Crossing shallow streams can create contamination or turbidity problems. Drill hole completion and site restoration should be formulated. Dust abatement may be necessary for travel over the access roads. Routes through planted fields should be arranged before travel.

### **Drilling**

Many factors should be considered during the development of the exploration plan as listed below:

- Are the drill sites on rock
- Can downhole hammers be used to set collar casing
- Are surficial materials suitable for hollow-stem auger use
- If the drill hole is to be water-pressure tested, may drilling mud or air foam be used

## DRILLING PROGRAMS

- Are soil samples required
- Can casing or hollow-stem augers be advanced through the surficial deposits so that rock coring can be performed
- Can the drill hole be used to combine geophysical and in-place testing
- Will geophysical testing be required in the drill hole
- Are angle holes required
- Will the holes require directional drilling control and then be verified by survey
- Will polyvinyl chloride (PVC) casing have to be installed for survey confirmation
- Will water pressure tests or permeability tests be required as the hole is drilled or can the testing be performed after the hole is completed
- Will the permeability tests require packers and pressure testing or gravity head pressure
- Will the holes require instrumentation installation
- What are the requirements for the backfill in the instrumentation drill hole and how is it to be placed
- Will the outside annulus of the casing require grouting
- What are the hole completion requirements

## FIELD MANUAL

### Equipment

- Are the requirements for soil sample and/or rock core sizes compatible with existing commercially available equipment
- Will the samples or cores have to be transmitted to the testing laboratories in sealed liners, split tube liners, thin-wall steel tubes, or cheesecloth and wax seals in core boxes
- Are there special concerns for the samples and their delivery
- Will those concerns require them to be transported in vibration-free containers
- Should the samples be protected from freezing
- Should the samples be weighed in the field and the density and moisture content determined before delivery to the laboratories
- What is the minimum drill equipment that should be specified considering the total hole depth, size of core or soil sample requirements, borehole diameter, and rod size
- What is the minimum mud pump or air compressor rating that should be specified
- Where is the water source; will water have to be hauled or can it be pumped to the drill site
- How much water line will have to be laid

## **DRILLING PROGRAMS**

### **Traffic Control and Safety**

- Will the drill locations require traffic control, detours, barricades, flag personnel, etc., for safety and public protection
- Will road or highway travel require rerouting during the drilling program
- Has permission been obtained from local, county, or state officials to close roads
- Will drilling be performed in high visibility areas
- Will equipment security and vandalism be enough of a problem to warrant nighttime security personnel or fencing

### **Special Considerations**

- Will the drilling require excavating or constructing ramps and drill pads on the slope face of an earth embankment
- Will the embankment slope face drilling have to be done with skid-rigs on timber cribbing platforms or with specialized drills that are capable of traversing and drilling into embankment slope faces without excavating ramps or benches
- Will underground drilling be required
- Establish and include all underground safety requirements in the drilling specifications
- Size the underground drilling equipment so it will be suitable for the height and width of the tunnel or drift

## FIELD MANUAL

- Is there potential for large water inflows
- Is there potential to intercept reservoir water during underground drilling operations
- Will the drilling program require drill setups on scaffolds or hanging platforms
- Are qualified personnel available to review the design of any scaffold or hanging platform drill setup, and will they have the authority to accept or reject the construction
- Will the drilling program require operation from a floating plant (barge) or a jack-up platform
- Obtain data for fluctuating river rises or falls, flow rate, and depth of water under normal flow conditions
- Will drilling be required in the vicinity of overhead transmission lines, transformer boxes, or underground buried utilities
- Have all underground utilities been located and flagged
- Will the program require helicopter service for fly-in rigs
- Have fly-in hazards been identified prior to start, such as transmission lines, heavy timber, turbulent winds, and rough terrain
- Are artesian pressures anticipated
- Are circulation loss zones anticipated
- Have contingency plans been prepared to seal and contain artesian water flow or large volume water flow that may be encountered during any drilling operations

## DRILLING PROGRAMS

- Has it been determined how the drill holes are to be completed, i.e., capped and locked collar casing, collar casing guard fixtures, or install piezometers or other monitoring instrumentation, or backfilled and grouted

### Drilling in Dam Embankments

The Bureau of Reclamation's (Reclamation) embankment design practice minimizes development of stress patterns within an embankment. Stress patterns could lead to hydraulic fracturing by drill fluids during drilling. Certain embankment locations and conditions have a higher potential for hydraulic fracturing than others, and improper drilling procedures or methods will increase the potential for hydraulic fracturing. Site locations and conditions where hydraulic fracturing by drilling media are more likely to occur and adversely affect a structure's performance include the following:

1. In impervious cores with slopes steeper than 0.5H:1V, cut-off trenches, and upstream-inclined cores.
2. Near abutments steeper than 0.5H:1V, where abrupt changes in slopes occur, and above boundaries in the foundation which sharply separate areas of contrasting compressibility.
3. Near structures within embankments.
4. In impervious zones consisting of silt or mixtures of fine sand and silt.

Recommended procedures for developing exploration and instrumentation programs and for drilling in the impervious portion of embankment dams are as follows:

## FIELD MANUAL

1. The embankment design should indicate whether a hydraulic fracturing potential exists.
2. If a high potential for hydrofracturing exists, the type of equipment and the method and technique to be used for drilling must have the approval of the exploration team. Once drilling has commenced, drilling personnel are responsible for controlling and monitoring drill media pressure, drill media circulation loss, and penetration rate to assure that the drilling operation minimizes the possibility for hydraulic fracturing.
3. If a sudden loss of drill fluid occurs during any embankment drilling within the dam core, drilling should be stopped immediately. Action should be taken to stop the loss of drill fluid. The reason for loss should be determined, and if hydraulic fracturing may have been the reason for the fluid loss, the geologist and designer should be notified.

With the exception of augering, any drilling method has the potential to hydraulically fracture an embankment if care is not taken and attention is not paid to detail. Augering is the preferred method of drilling in the core of embankment dams. Augering does not pressurize the embankment, and no potential for hydrofracturing exists. Use of a hollow-stem auger permits sampling in the embankment and allows sampling/testing of the foundation through the auger's hollow stem, which acts as casing.

Drilling methods which may be approved for drilling in embankment dams if augering is not practical (i.e., cobbly fill) are as follows:



## DRILLING PROGRAMS

1. Cable tool
2. Direct rotary with mud (bentonite or biodegradable)
3. Direct rotary with water
4. Direct rotary with air-foam
5. Down-hole hammer with reverse circulation

Selection of any one of the above methods should be based on site-specific conditions, hole utilization, economic considerations, and availability of equipment and trained personnel.

Any drilling into the impervious core of an embankment dam should be performed by experienced drill crews that employ methods and procedures that minimize the potential for hydraulic fracturing. It is essential that drillers be well trained and aware of the causes of and the problems resulting from hydraulic fracturing.

### **Safety**

Drilling safety requirements and safety requirements in general are available in *Reclamation Safety and Health Standards*, Bureau of Reclamation, United States Department of Interior, 1993.

### **Preparation of Drilling Specifications and Format**

The work requirements should be compiled in a clear and concise manner for use by the personnel who will

## FIELD MANUAL

perform and inspect the work. The following is a suggested specifications format for drilling contracts.

### **a. General Description of Exploration Program**

- (1) Available Geologic Data
- (2) Identification of Design Concerns
- (3) Generalized Exploration Drilling, Coring, Testing, Instrumentation Requirements

### **b. Location of Work**

- (1) Area Identification
- (2) Nearest Community
- (3) Emergency Facilities
- (4) Nearest Living Quarters/Crew Camp Area
- (5) Freight Facilities
- (6) Fuel and Supply Business Locations
- (7) Travel Routes/Road Restrictions
- (8) Public/Private Land Access Routes/Restrictions
- (9) Right-of-Way Permits

### **c. Site Location**

- (1) Hole Locations
- (2) Topography/Accessibility

## DRILLING PROGRAMS

- (3) Protection of the Environment
- (4) Water Source
- (5) Waste Disposal Area/Acceptable Waste Disposal Method
- (6) Drill Yard Storage Area—Restrictions

### **d. Work Requirements**

- (1) Site Preparation
- (2) Collaring Holes—Boring Size—Angle
- (3) Casing Requirements
- (4) Sample Requirements (Disturbed/Undisturbed)
- (5) Sample Sizes and Intervals
- (6) Care and Transportation of Samples
- (7) Core Sizes and Intervals
- (8) Care and Preservation of Rock Core
- (9) In-Place Testing Requirements
- (10) Instrumentation Requirements
- (11) Hole Backfill and Completion
- (12) Site Cleanup

## **FIELD MANUAL**

### **e. Equipment Requirements**

- (1) Drill Rig Capabilities
- (2) Pump/Air Compressor Capabilities
- (3) Drilling Media
- (4) Sampling/Coring Equipment
- (5) In Situ Testing Equipment
- (6) Instrumentation Equipment
- (7) Core Boxes/Sample Containers

### **f. Special Drilling Concerns**

#### **g. Potential for Program Change, Modification, or Extension**

#### **h. Safety Program/Safety Requirements/Safety Contingency Plans**

#### **i. Exploration Drilling Reports and Logs**

#### **j. Labor Checks/Equipment Checks/Cost Accounting**

## Chapter 9

# GROUNDWATER DATA ACQUISITION METHODS

### Introduction

This chapter provides information that will help select, install, and operate appropriate groundwater instrumentation and to collect, establish, maintain, and present the groundwater data. Most types of engineering geology investigations require acquisition and use of groundwater data. The data required may vary from simple monthly verification of the water level elevations along a canal-axis profile to hourly monitoring of piezometric conditions in multiple zones within a landslide or embankment. Successful implementation of a groundwater instrumentation program depends on knowledge of subsurface conditions, preliminary identification of all probable future uses of the data, and careful planning of an instrumentation system and data acquisition program to meet these data requirements. This chapter will provide the user with:

- A detailed description of methods employed in designing and installing groundwater monitoring systems.
- A detailed description of available manual and automated methods and techniques used in monitoring ground and surface water.
- A discussion of data base management and data presentation.
- A listing of more detailed and specific source material on groundwater data acquisition methods.

## FIELD MANUAL

### General

The importance of fully evaluating and understanding geologic factors controlling groundwater flow—including porosity, storativity, permeability, transmissivity, velocity, recharge, and discharge—cannot be overemphasized. This evaluation needs to be made at the onset of the exploration program and continually repeated throughout the investigations. These factors will ultimately control the type of groundwater acquisition methods required.

### Geologic Controls on Groundwater

Geologic controls on groundwater flow impact the design of observation systems and must be identified in the preliminary planning of the instrumentation program. For example:

1. Permeable materials, such as clastic sediments, karstic limestone, and fractured rock, control the type and size of well point, well screen, or piezometer to be used and must be accounted for in designing instrumentation for the program.
2. Relatively impermeable materials, such as clays, silts, shales, siltstones, and massive rock present special problems which must be accounted for in selecting the type and size of piezometer to be installed. Generally these materials require use of the smallest size piezometer practical because changes in water level and volume in the hole are small and require long periods of time to react. Pore pressure measurements in this type of geologic environment should be considered, particularly if short-term periodic—daily or weekly—changes in groundwater conditions are needed.

## GROUNDWATER

3. Layering, attitude of layers, boundaries, weathering and alteration, and environment of deposition all influence selection of instrumentation.

### **Design and Installation of Observation Wells and Piezometers**

#### **Analysis of the Geologic Environment**

The presence of variations in the geologic environment must be anticipated. Perched water tables, artesian aquifers, sources of recharge and discharge, known boundaries and barriers, and structural controls such as fractures, joints, faults, shears, slides, folds, and stratigraphic contacts should be considered when selecting instrument types and sizes. The preliminary instrumentation design should be advanced enough to allow procurement of needed equipment, but flexible enough to adapt to changes in the environment.

Different types of groundwater observation instruments provide different data types. Observation wells and piezometers are selected in accordance with the data required and the aquifer material and type. To be useful, reliable, and accurate, the well or piezometer design must be tailored to the subsurface conditions. Single or unconfined aquifer zones can be monitored by using a screened or perforated standpipe or porous tube piezometer, or by a pore-pressure transducer. Multiple zones may be monitored using multiple drill holes, multiple piezometers in a single drill hole, or multiple piezometer ports in a single standpipe.

## FIELD MANUAL

### Design

The most important aspect in the design of a groundwater monitoring well is the purpose and use of the well; whether for taking water samples, measuring water levels, geophysical investigations, or a combination of uses.

The hydrogeologic environment and the type of down-hole instruments that may be used in the well will influence the choice of well diameter, casing type, screen to be used, and the interval to be monitored.

Components of a typical well include a screened interval surrounded by filter/gravel-pack material isolated by a bentonite and/or cement grout seal, blank casing to the surface, and a protective well cover.

PVC is the most widely used material for standpipes (casing and screens) in monitoring wells. It is relatively inexpensive and presents few chemical interferences in water quality sampling. Many other materials are available for specific uses, including galvanized and stainless steel, Teflon<sup>®</sup>, and other plastics.

The diameter of the well depends on the instrumentation to be installed and the intended use. If the well is to be sampled, by either pump or bailer, a 3-inch (75-mm) diameter hole is the preferred size for accuracy and for complete development of the hole, but smaller sizes can be used with small bailers and peristaltic pumps. Wells used for measuring water levels only may be smaller diameter or may have multiple small diameter standpipes within a 4-inch (100-mm) to 8-inch (200-mm) diameter hole. A standpipe designed to accommodate an M-scope water level sensor can be  $\frac{3}{4}$  inch (19 mm) diameter. However, if the standpipe is to be



## GROUNDWATER

instrumented with a pneumatic or vibrating wire piezometer or if a recorder and electric probe will be used to monitor the water level, then the diameter of the standpipe depends on the size of the instrument or transducer to be installed. Lengths of well screen and casing (PVC perforated and solid standpipe) must have uniform inner and outer casing diameters. Inconsistent inner diameters cause problems when instruments with tight clearance are lowered into the well. The pipe may need to be reamed to remove the beads and burrs. A filter pack is generally composed of washed sand and gravel and is placed within the screened interval. The interval may extend above the screen depending on the zone thickness. The pack is designed primarily to allow water to enter the standpipe while preventing the movement of fines into the pipe through the slots, and to allow water to leave the standpipe when water levels drop. If the well is to be used for sampling, the pack material should be sterilized to prevent possible contamination before placement into the well. The gravel pack should be tremied through a pipe to prevent bridging. The top of the pack may be checked using a small diameter tamping tool, or a properly weighted surveyor's tape.

A seal is installed to create an impermeable boundary between the standpipe and the casing or drill hole wall. The seal should be placed in a zone of low permeability, such as a clay bed above the zone to be monitored. This ensures that water will not travel vertically along the casing or drill hole.

Cement grout can shrink due to temperature changes during curing and may crack. This causes a poor bond between the grout and the standpipe. A 1-foot (0.3-m) bentonite seal should be placed preferably as pellets or by tremieing a bentonite slurry immediately below and

## FIELD MANUAL

above the cement grout seal. This helps ensure a reliable plug. Any seal material (optional with bentonite pellets) should be tremied into place. This prevents bridging or caking along the hole wall. The seal must be reliable so that the screened interval monitors only the desired groundwater zone.

A drill hole containing multiple standpipes, each monitoring a zone or distinct water bearing strata, may have several isolating seals. To test the integrity of the seals, a gravity head test may be performed by adding water to the shallowest standpipe and continuously measuring the water level in the next lower piezometer to detect any leakage through or around the seals. If the water leaks into the lower interval, the piezometric head will rise in the lower standpipe.

A protective cover helps prevent damage to the standpipe and reduces surface water drainage into the backfilled hole. The casing should extend 5 to 10 feet (1.5 to 3 m) below ground and be grouted into place. Upon completion of the monitoring well, standpipe should be bailed or blown dry and the water level allowed to recover to a static level. A completion log should be prepared using the drillers' records, geologic log, and measurements. The log should include the actual depths and thicknesses of each component of the well; the standpipe's total depth; the screened interval, the isolated interval; the type of filter pack; the depth, thickness, and type of isolating seals; and a reference point from which all measurements were taken, such as top of casing or ground surface. Many excellent references are available to design and install groundwater monitoring wells for various purposes. Refer to these at the end of this chapter for more detailed instructions.

## GROUNDWATER

### Construction Materials

Construction materials for observation wells and piezometers are dictated by the projected use of the instrument and the permeability of the aquifer. The diameter of the standpipe, the type of standpipe used (metal versus plastic), screen slot size/porous tube type, and gravel pack material are all variables dictated by aquifer characteristics.

In a relatively permeable material, the diameter of a standpipe is not critical; sand or gravel pack around the well tip may not be required, but the screen slot size may be critical to the success of the installation. Too small screen or slot size may restrict instrument reaction to changes in water levels.

In a relatively impermeable material, pipe diameter may be critical, a pack material of select sand or fabric wrap usually is required, and a well point or screen assembly usually is needed, (0.010-0.020-inch [0.025-0.05 centimeter (cm)] slot size). Generally, the smallest diameter pipe practical should be used in this sort of monitoring application, keeping in mind that the standpipe diameter must be large enough to install a means of measuring water levels. If the volume of the hole is too large, too much water must move in and out of the hole to accurately reflect the water level. If rapid reaction to water level or changes is needed, a pressure transducer may be more appropriate than an open-tube piezometer or standpipe.

A variety of materials can be used as the standpipe. Polyvinyl chloride (PVC) plastic pipe is economical and easy to install. Plastic pipe is fairly fragile, deformable, and can be destroyed accidentally during installation. Metal pipe is more durable for installation but generally

## FIELD MANUAL

costs more than plastic, rusts or corrodes, and is subject to iron bacterial action. Generally, if grout plugs are used to isolate zones, black pipe is preferred because the zinc in galvanized pipe can react with the plug and destroy the seal. The inside diameter (I.D.) of the pipe depends on the permeability of the aquifer material and can vary from as small as  $\frac{1}{2}$  inch (13 millimeters [mm]) to 2 inches (50 mm) or larger. The diameter of the riser is critical to instrumentation of the observation well or piezometer. Generally,  $\frac{3}{4}$ -inch (19 mm) pipe is the smallest practical size that can be used in automated applications. Reaming of the pipe prior to installation to remove burrs, weld seams, and blebs of galvanizing material is a necessary precaution to ensure that the standpipe will be usable if the pipe I.D. and measuring device outside diameter (O.D.) are close.

The screen assembly selected for an observation well or piezometer can be a well point, well screen, porous tube, or perforated pipe (commercially manufactured or field fabricated). Screen should be PVC or corrosion-resistant metal. Slot-size is determined by filter material size and aquifer material.

The gravel-pack material selected is determined by the particle sizes of the aquifer material and the size of the well screen. Concrete sand or reasonably well-graded sand to pea gravel can be used.

Plug material used to isolate the interval to be monitored can be tremied cement grout, bentonite pellets, or a combination of the two. A bentonite slurry also may be used in some instances but must be tremied in place. Bentonite pellets are preferred if only one isolation method is used.

# GROUNDWATER

## Methods Used to Measure Groundwater Levels

### General

Groundwater measurements (and any instrumentation readings) should be interpreted concurrently with reading. Erroneous readings and faulty equipment need to be detected as encountered, and timely interpretation is a reliable method of bad reading detection. The person(s) taking the readings must understand the equipment and gather reliable data from the instruments. If bad readings or faulty equipment are not detected by concurrent interpretation, months of irretrievable data can be lost, and erroneous interpretations or data impossible to interpret can result.

### Manual Methods Used to Measure Groundwater Levels

**Chalk and Surveyors' Chain.**—Probably the oldest and one of the most reliable methods for measuring wells is the surveyors' chain and chalk method. This method is not recommended where water level depths exceed several hundred feet (300 m+).

A lead weight may (but not necessary) be attached to a steel measuring tape (surveyors' chain). The lower 5 feet (1.5 m) of the tape is wiped dry and covered with solid carpenter's chalk if the water level is roughly known. The tape is lowered into the well, and one of the foot marks is held exactly at the top of the casing. The tape is pulled up. The line can be read to a hundredth of a foot (0.003 m) on the chalked section. This reading is subtracted from the mark held at the measuring point, and the difference is the depth to water.

## FIELD MANUAL

The disadvantage to this method is that the approximate water depth must be known so that a portion of the chalked section will be submerged to produce a wetted line. Deep holes require a long surveyor's chain which can be difficult to handle.

**M-Scope (Electric Sounder).**—An M-scope is an electric sounder or electrical depth gauge consisting of an electrode suspended by a pair of insulated wires and a milliammeter that indicates a closed circuit and flow of current when the electrode touches the water surface. Usually, AA flashlight batteries supply the current. The insulated wire usually is marked off in 1-foot to 5-foot (0.3- to 1.5-m) intervals. The best devices have the measuring marks embedded directly into the line. Markers that are attached to the line slip, making it necessary to calibrate the instrument frequently.

With the reel and indicator wire in one hand and the other hand palm up with the index finger over the casing or piezometer pipe, the wire is lowered slowly over the finger into the piezometer pipe or well casing. By sliding the wire over the finger, the wire is not cut or damaged by the sharp casing or piezometer pipe. Several readings can be taken to eliminate any errors from kinks or bends in the wire. The water level depth can be measured from the top of casing using the mark-tags on the insulated wire and a tape measure marked in tenths and hundredths of a foot. The advantage of this method is that water level depths in holes several hundred feet deep can be measured fairly quickly and accurately. The disadvantage to this method is that malfunctioning or mechanical problems develop in the instrument giving erroneous water level readings. Before going into the field, the instrument must be checked for low batteries, tears, scrapes on the insulated wires, and iron-calcium buildup on the part of the electrode touching the water surface.

## GROUNDWATER

**Airline and Gauge.**—This method uses a small diameter pipe or tube inserted into the top of the well casing down to several feet below the lowest anticipated water level. The exact length of airline is measured as the line is placed in the well. The airline must be air tight and should be checked. The airline must hang vertically and be free from twists and spirals inside the casing. Quarter-inch (6.3 mm) copper or brass tubing can be used. The upper end of the airline is fitted with suitable connections and a Schraeder valve so that an ordinary tire pump can be used to pump air into the tube. A tee is placed in the line so that air pressure can be measured on a pressure gauge.

This device works on the principle that the air pressure required to push all the water out of the submerged portion of the tube equals the water pressure of a column of water of that height. A reference point (e.g., top of casing or pipe) and the depth to the lower end of the airline must be known. Air is pumped into the airline until the pressure on the gauge increases to a maximum point where all the water has been forced out of the airline. At this point, the air pressure in the tube just balances the water pressure. The gauge reading shows the pressure necessary to support a column of water of a height equal to the distance from the water level in the well to the bottom of the tube.

If the gauge reads the direct head of water, the submerged length of airline is read directly. The total length of airline to the reference point, minus the submerged length gives the depth to water below the measuring point. If the gauge reads in pounds per square inch, multiply the reading by 2.31 to convert to feet of water. An accurate, calibrated gauge and a straight, air-tight airline are important.

## FIELD MANUAL

**Popper.**—A simple and reliable method of measuring water levels is with a popper. A tape with a popper attached to the bottom is lowered into the well or casing until the water is reached, as indicated by a pop. The popper is raised above and lowered to the water surface several times to accurately determine the distance. A popper consists of a small cylinder closed at the top and open at the bottom. The open bottom causes a popping sound when the water surface is hit. A 1-inch (in) or 1½-in (25- or 40-mm) pipe nipple 2 to 3 in (50 to 75 mm) long with a cap on top works satisfactorily.

**Pressure Gauge for Monitoring Artesian Wells.**—Additional standpipe or casing can theoretically be extended to eventually equal the head of the water. A simple method to determine the artesian head is to attach a pressure gauge to the casing or the piezometer pipe. The gauge selected may be read directly or in feet (meters) of water. Install a tee on the standpipe or on the casing so that a pressure gauge and valve can be attached to the tee. The valve may be used to bleed the pressure gauge to see if the gauge is working and can be used to measure the flow on the artesian well. When a pressure reading is taken, a flow measurement should also be taken. During the winter months, the valve should be cracked open to allow the well to flow slightly to prevent the riser pipe from freezing and breaking. The line to the gauge should be bled of water. If the pressure gauge used is in lbs/in<sup>2</sup>, multiply the gauge reading by 2.31 to obtain the head of water above the valve.

### Continuous Recorders

**Stevens Recorder.**—The Stevens Recorder (produced by Stevens Water Resources Products) provides a reliable and economical way to obtain continuous water



## GROUNDWATER

level data. The recorder is a float type consisting of a 3- to 6-inch (76- to 152-mm) float connected to a pulley which turns a calibrated gear-driven drum. A power source, such as a spring clock or small motor, rotates the drum at a known rate giving a constant indication of elapsed time.

Gearing between the float pulley and the chart drum provide a changeable ratio of water movement to pen movement on the chart. A time scale is available on the chart, and continuous recordings may be maintained for up to several months. When a Stevens recorder is used in a well, the minimum diameter of the well casing is 4 inches (100 cm). An advantage of the Stevens recorder is versatility. Hydrographs can be created with scales of 1:1 to 1:20. Most recorders can be set from 4 hours to several months. Johnson-Keck has a water level sensing instrument that can continuously record water levels in ½-inch (13-mm) pipe and larger. Transistorized circuitry is used to control a battery powered motorized reel. The sensing float is attached to one end of the control wire, and the other end of the wire is connected to the reel. The instrument is connected to a Stevens type F or Stevens type A recorder. The control wire passes around the recorder pulley, and the sensing device is placed in the casing. The sensing device seeks the water surface; and once the water surface is found, the circuitry keeps the sensing device at the water surface.

Many float recorders can be attached to digital recorders for continuous records. Data from this type of instrument can be used and easily interfaced with a computer system.

**Bristol Recorders.**—Recorders for monitoring continuous artesian pressures are produced by Bristol Instrument Systems. The Bristol and Stevens recorders are similar in that pressure and time are recorded on a

## FIELD MANUAL

chart. The instrument usually contains diaphragms that can be adjusted to varying pressure conditions. The spring-driven clock usually is calibrated for 30 days. The Bristol recorder is very useful for observing pressure changes in artesian wells but is limited by freezing conditions in northern climates. A pressure gauge installed in the line between the artesian water and the pressure recorder is very useful. This gauge provides a good indication of the working condition of the instrument.

**Gas Bubbler Transducer.**—Pneumatic or gas bubble transducers are manufactured by many companies. The transducers vary from a single readout box to a complicated array of instruments that will measure several wells at once. A gas is forced through a tube at a constant rate past a diaphragm. When the pressure of the gas on the diaphragm and the water pressure on the other side of the diaphragm are equal, a constant reading is obtained. This reading equals the amount of water over the diaphragm. This number multiplied by 2.31 will give the amount of water head over the instrument. These instruments may be used as a single unit or connected into an electronic data acquisition system.

**Maintenance.**—A good maintenance program is necessary to ensure reliable performance of mechanically actuated recorders. The instruments and data collected are only as good as the preventive maintenance. A routine preventive maintenance program should be scheduled for all the instruments. In some cases, daily inspection of recorders is required; however, if the instrument is working properly, weekly inspections may be sufficient. Preventive maintenance can often be accomplished when the charts are changed.

## GROUNDWATER

### Methods and Techniques Used to Estimate Flows from Seeps, Springs, and Small Drainages

A thorough and detailed discussion of weirs, flumes, stilling wells, and other techniques is presented in Reclamation's *Water Measurement Manual* [1]. Small seeps, springs, and intermittent drainages are often encountered in field investigations. These features can provide key information during design and construction and may be key indicators of structure performance or environmental impacts that may affect the project. The location of drainage features, the rate of flow, and the time of year of the observation are important information. Flow can be estimated accurately using the methods described below:

Estimate the rate of flow in an open channel using  $Q=VA$ , where:

$Q$  = rate of flow

$V$  = velocity

$A$  = cross sectional area of channel

The cross-sectional area is determined by direct measurements where possible. Where impractical, the cross-sectional area may be estimated or scaled from a topographic map.

Velocity is determined using a float, a measuring tape, and a stop watch by timing how long a floating object takes to travel a given distance. This provides a crude but reasonably accurate estimate of flow. Other methods may include a pitot tube or flow meter.

Substitute the values obtained into the  $Q=VA$  equation to obtain the volume of flow.

## FIELD MANUAL

Measure flow from small springs and seeps directly by diverting the flow, or in some manner channel the flow to a point for collection in a container, such as a bucket. Determine the rate of flow by timing how long it takes to fill the container. Select points along a drainage where abrupt dropoffs occur and use this method. It is better to measure, however crudely; but if not possible, estimate the flow. Many more sophisticated methods can be used to obtain more accurate flow measurements, if necessary. Determination of the most appropriate method can be made if preliminary data are available.

### **Computer-Based Monitoring Systems**

#### **General**

Water level monitoring may be automated. Monitoring landslides can require a great number of points and frequent readings. A variety of data types may be required, which may include measurements of not only water levels and pore pressure changes, but deformation and movement as well. Systems required to collect, store, format, and present these data are available allowing realtime analysis of a wide variety of data types.

#### **Components of a Computer-Based Monitoring System**

1. Many types of instruments including inclinometers, pressure transducers, strain gauges, water level gauges, and flowmeters can be used in a monitoring system. Electronic instruments are available in many sizes and shapes; preliminary selection of the instrument type

## GROUNDWATER

should be made during the initial design of the system. The inside diameter of the well must be sized to accept the transducer.

2. Acquired data is sent from the instrument at the well to the data logger or processor. This is done by hardware from the instrument, line-of-sight radio, satellite radio, or phone lines.

Data from the monitoring points may be preprocessed in the field prior to transmittal to the central computer. A number of microprocessor data scanners that collect and reduce data can be installed at various field locations. The central computer queries the field scanners to obtain periodic updates. The remote scanners can be interrogated as frequently as desired. This may include a continuous data scan mode.

3. Data scanners reduce the instrument output to usable data. Data scanners can be the end destination for more simple systems or can be part of a more elaborate system. Generally, two types of signals are generated by instruments used in geotechnical monitoring: (a) digital and (b) analog current or voltages. Data scanners which accept and reduce data from both types of signals are available.

Many manufacturers offer complete packages of automated instrumentation systems, including computer hardware and software. If the initial observation well program is designed for automation, most of these systems will provide the high quality data required.

### **Special Applications**

Many types of instrumentation can be used in a single drill hole. A multiple use casing collects groundwater

## FIELD MANUAL

data from a large number of horizons within a single drill hole. Casing is available specifically for pore-pressure observations, or grooved casing can be used so that the well can be completed for both pressure and inclinometer measurements. Isolation between horizons can be accomplished either by installing a bentonite seal or by using a packer assembly designed as an integral part of a monitoring system. Use of a monitoring system greatly reduces drilling costs, provides detailed monitoring of critical drill holes, and provides a greater flexibility than systems previously available. Small diameter drill holes can be used to obtain a large number of isolated water level intervals and, depending on the application, can be very cost effective.

### **Data Base Management and Data Presentation**

Standard forms are available to record field data, although standard data sheets often must be modified for specific applications. Data sheets must include remarks and information that include the monitoring well number, location, elevation reference points, type and size of well, dates and times the well was read, depth to water, and the elevation of the water surface. Periodic readings of these observation wells over long periods of time generate numerous data sheets. Computerization of the data base very rapidly can become a necessity if data are to be readily available and easily analyzed.

Data entry and storage in digital format allows electronic transfer of data and greater flexibility in developing, analyzing, and presenting data. Data may be tabulated or presented as time-depth/elevation plots and interpretive drawings such as contours and other three dimensional plots. Tremendous volumes of data

## GROUNDWATER

can be reduced quickly to a usable format. Use of a commercially available data base allows data use and manipulation without specialized software or training.

### Definitions

**Aquifer**—A body of soil or rock that is sufficiently permeable to conduct groundwater and to yield economically significant quantities of water to wells and springs.

- **Confined aquifer**—An aquifer bounded above by impermeable beds, or beds of distinctly lower permeability than that of the aquifer itself. An aquifer containing confined groundwater.

- **Unconfined aquifer**—An aquifer having a water table. An aquifer containing unconfined ground-water.

**Artesian**—An adjective referring to groundwater confined under hydrostatic pressure.

**Artesian aquifer**—An aquifer containing water under artesian pressure.

**Aquitard**—A confining bed that retards but does not prevent the flow of water to or from an adjacent aquifer; a leaky confining bed. An aquitard does not readily yield water to wells or springs but may serve as a storage unit for groundwater.

**Aquiclude**—A body of relatively impermeable rock or soil that is capable of absorbing water slowly but functions as an upper or lower boundary of an aquifer and does not transmit significant groundwater.

## FIELD MANUAL

**Water table or water level**—The surface between the zone of saturation and the zone of aeration; the surface of a body of unconfined groundwater at which the pressure is equal to atmospheric pressure.

**Zone of aeration or Vadose zone**—Subsurface zone containing water under pressure less than atmospheric, including water held by capillarity, and containing air or gases generally under atmospheric pressure. This zone is limited above by the land surface and below by the surface of the zone of saturation or water table.

**Saturation**—The maximum possible content of water in the pore space of rock or soil.

**Zone of saturation**—A subsurface zone in which all of the interstices are filled with groundwater under pressure greater than atmospheric. The zone is still considered saturated even though the zone may contain gas-filled interstices or interstices filled with fluid other than water. This zone is separated from the zone of aeration by the water table.

### References

American Geological Institute, *Glossary of Geology*, 4th edition, Alexandria, VI, 1997.

Bureau of Reclamation, *Embankment Dam Instrumentation Manual*, U.S. Department of the Interior, United States Government Printing Office, Washington, DC, 1987.

Bureau of Reclamation, *Ground Water Manual*, 2nd edition, A Water Resources Technical Publication,



## GROUNDWATER

U.S. Department of the Interior, United States Government Printing Office, Washington, DC, 1995.

Driscoll, Fletcher G., *Groundwater and Wells*, 2nd edition, published by Johnson Division, St. Paul, MN 55112, 1987.

Leupold and Stevens Inc., *Stevens Water Resources Data Book*, 3rd edition, P.O. Box 688, Beaverton, OR 97005.

Morrison, Robert D., "Equipment, and Application," *Ground Water Monitoring Technology Procedures*, Timco Manufacturing Inc., Prairie du Sac, WI, 1983.

## BIBLIOGRAPHY

- [1] Bureau of Reclamation, *Water Measurement Manual*, 3rd edition, A Water Resources Technical Publication, U.S. Department of the Interior, United States Government Printing Office, Washington, DC, 1997.



## **Chapter 10**

# **GUIDELINES FOR CORE LOGGING**

These guidelines incorporate procedures and methods used by many field offices and are appropriate for "standard" engineering geology/geotechnical log forms, computerized log forms, and many of the modified log forms used by various Bureau of Reclamation (Reclamation) offices.

### **General**

#### **Introduction**

This chapter describes the basic methods for engineering geology core logging and provides examples and instructions pertaining to format, descriptive data, and techniques; procedures for working with drillers to obtain the best data; caring for recovered core; and water testing in drill holes. The chapter also provides a reference for experienced loggers to improve their techniques and train others. Most of the discussions and examples shown pertain to logging rock core, but many discussions apply to soil core logging, standard penetration resistance logs, and drive tube sample logging.

#### **Purpose, Use, and Importance of Quality Core Logging**

The ability of a foundation to accommodate structure loads depends primarily on the deformability, strength, and groundwater conditions of the foundation materials. The remediation of a hazardous waste site can be formulated only by proper characterization of the site. Clear and accurate portrayal of geologic design and evaluation data and analytical procedures is paramount. Data reported in geologic logs not only must be accurate,

## FIELD MANUAL

consistently recorded, and concise, but also must provide quantitative and qualitative descriptions.

Logs provide fundamental data on which conclusions regarding a site are based. Additional exploration or testing, final design criteria, treatment design, methods of construction, and eventually the evaluation of structure performance may depend on core logs. A log may present important data for immediate interpretations or use, or may provide data that are used over a period of years. The log may be used to delineate existing foundation conditions, changes over time to the foundation or structure, serve as part of contract documents, and may be used as evidence in negotiations and/or in court to resolve contract or possible responsible party (PRP) disputes.

For engineering geology purposes, the basic objectives of logging core are to provide a factual, accurate, and concise record of the important geological and physical characteristics of engineering significance. Characteristics which influence deformability, strength, and water conditions must be recorded appropriately for future interpretations and analyses. Reclamation has adopted recognized indexes, nomenclature, standard descriptors and descriptive criteria, and alphanumeric descriptors for physical properties to ensure that these data are recorded uniformly, consistently, and accurately. Use of alphanumeric descriptors and indexes permits analysis of data by computer. These descriptors, descriptive criteria, examples, and supporting discussions are provided in chapters 3, 4, and 5.

Exploration should be logged or, as a minimum, reviewed by an experienced engineering geologist. The logger should be aware of the multiple uses of the log and the needs and interests of technically diverse users. The

## CORE LOGGING

experienced logger concentrates on the primary purposes of the individual drill hole as well as any subordinate purposes, keeping in mind the interests of others with varied geological backgrounds including geotechnical engineers, contract drillers, construction personnel, and contract lawyers. An experienced logger tailors the log to meet these needs, describing some seemingly minor features or conditions which have engineering significance, and excluding petrologic features or geologic conditions having only minor or academic interest. Less experienced loggers may have a tendency to concentrate on unnecessary garnishment, use irrelevant technical terms, or produce an enormously detailed log which ignores the engineering geology considerations and perhaps the purpose for completing the drill hole. Adequate descriptions of recovered cores and samples can be prepared solely through visual or hand specimen examination of the core with the aid of simple field tests. Detailed microscopic or laboratory testing to define rock type or mineralogy generally are necessary only in special cases.

Empirical design methods, such as the Rock Mass Rating System Geomechanics Classification (RMR) and Q-system Classification (Q), are commonly used for design of underground structures and are coming into common use for other structures as well. If these methods are used, the necessary data must be collected during core logging.

If hazardous waste site characterization is the primary purpose of the drilling, the log should concentrate on providing data for that type of investigation.

Drilling and logging are to determine the in-place condition of the soil or rock mass. Any core condition, core loss, or damage due to the type of bit, barrel, or other equipment used, or due to improper techniques used in

## FIELD MANUAL

the drilling and handling processes should be described. Such factors may have a marked effect on the amount and condition of the core recovered, particularly in soft, friable, weathered, intensely fractured materials or zones of shearing. Geologic logs require the adequate description of materials; a detailed summary of drilling equipment, methods, samplers, and significant engineering conditions; and geologic interpretations. Complete geologic logs of drill holes require adequate descriptions of recovered surficial deposits and bedrock, a detailed summary of drilling methods and conditions, and appropriate physical characteristics and indexes to ensure that adequate engineering data are available for geologic interpretation and analysis.

### **Format and Required Data for the Final Geologic Log**

#### **Organization of the Log**

The log forms are divided into five basic sections: a heading block; a left-hand column for notes; a center column for indexes, additional notes, water tests and graphics; a right-hand column for classification and physical conditions; and a comments/explanation block at the bottom. Data required for each column are described in the following discussion and the referenced example logs. Log DH-123, figure 10-1, and log B-102, figure 10-2, are the most complete and preferred examples; other variations are presented but in some cases are not complete.

#### **Heading**

The heading block at the top of the form provides spaces for supplying project identifying information, feature,

# CORE LOGGING

GEOLOGIC LOG OF DRILL HOLE										SHEET 1 OF 2
FEATURE - EXAMPLE		PROJECT - Engineering Geology Manual			STATE					
HOLE NO. - DH-123		LOCATION - Channel, 600th Ave			Deck Elev. 2139.7		DIP (ANGLE FROM HORIZ.) - 90°			
BEGIN - 8-23-81		FINISHED - 9-8-81			DEPTH OF OVERBURDEN		TOTAL DEPTH 134.3			
DEPTH AND ELEV. OF WATER LEVEL AND DATE MEASURED		See Notes			LOGGED BY F. J. Miller		LOG REVIEWED BY S. R. Cowling			
NOTES ON WATER LOSSES AND LEVELS, CASING, CEMENTING, CAVING, AND OTHER DRILLING CONDITIONS	TYPE AND SIZE OF HOLE RECOVERY	PERCOLATION TESTS						DEPTH (FEET)	GRAPHIC LOG	CLASSIFICATION AND PHYSICAL CONDITION
		DEPTH (FEET)	LOSS (G.P.M.)	RESURGE (FEET)	PERCENTAGE OF HOLE RECOVERY	ELEV. (FEET)	GROUND ELEV.			
<p>Purpose of Hole: Foundation investigation of powerplant</p> <p>Location and Setup: Located 25 ft. rt. of Mag centerline, sta. 2085, level pad, excavated approx. 1.5 ft. of material for drill setup. All depth measurements from deck.</p> <p>Drillers: L. Harding and P. Smith.</p> <p>Drilling Equip.: Skid-mounted Long-year 36, hydraulic feed, rotary drill. No drill rods.</p> <p>Drilling Methods: 11.0-3.0": 35° rock bit. 3.0-7.3": NMD3 core barrel w/split-tube inner barrel. No side-discharge diamond bit, and clear water.</p> <p>7.3-9.2": 35° rock bit.</p> <p>9.2-134.3": Same as 3.0-7.3" interval.</p> <p>63.6-79.1": Used Revert mud.</p> <p>Drilling Conditions and Drillers</p> <p>Comments:</p> <p>11.0-10.3": Fast and smooth.</p> <p>10.3-29.8": Drilled moderately fast and rough.</p> <p>29.8-50.3": Drilled slow and smooth.</p> <p>50.3-63.6": Slow, rough, blocky.</p> <p>63.6-118.8": Slow to fast, smooth to slightly rough.</p> <p>118.8-134.3": Slow and smooth.</p> <p>Casing Conditions:</p> <p>11.0-10.0": Heavy</p> <p>11.5-18.5": Light</p> <p>51.0-63.6": Heavy</p> <p>115.8-129.1": Moderate</p>	RR	0	Infiltrable	No packer	55	2137.9		0.0-0.5': Deck		
	NH	47		(Packer No. 12) and Max volume all packer tests.	55			0.5-10.8": Quaternary Alluvium		
	D3	47						10.8-63.2": TERTIARY VOLCANICS		
	D3	47						63.2-134.3": Jurassic Metamorphics		
	RE	0.0	11.6	15	G	20	2128.4		0.0-0.5': Deck	
	NH	65		(casing to R.0')				0.5-10.8": Quaternary Alluvium		
	D3	98	0.6	20.6	18	G	20	0.5-10.8": Quaternary Alluvium		
		100						0.5-10.8": Quaternary Alluvium		
		100						0.5-10.8": Quaternary Alluvium		
		97						0.5-10.8": Quaternary Alluvium		
		100						0.5-10.8": Quaternary Alluvium		
		30						0.5-10.8": Quaternary Alluvium		
		35.7	45.7	0.1	25	5	2106.4		0.5-10.8": Quaternary Alluvium	
		97						0.5-10.8": Quaternary Alluvium		
		45						0.5-10.8": Quaternary Alluvium		
		44.8	54.8	0.0	25	5	2097.1		0.5-10.8": Quaternary Alluvium	
		100						0.5-10.8": Quaternary Alluvium		
		50	53.6	63.6	25	5	2080.6		0.5-10.8": Quaternary Alluvium	
		95		28.7	40	5			0.5-10.8": Quaternary Alluvium	
				14.1	25	5			0.5-10.8": Quaternary Alluvium	
	86							0.5-10.8": Quaternary Alluvium		
	98	3.6	23.6	0.6	25	5	2076.0		0.5-10.8": Quaternary Alluvium	
	97		1.1	50	5			0.5-10.8": Quaternary Alluvium		
			0.4	25	5			0.5-10.8": Quaternary Alluvium		
	70							0.5-10.8": Quaternary Alluvium		
	100							0.5-10.8": Quaternary Alluvium		
	100							0.5-10.8": Quaternary Alluvium		
	78.0	RR.0	Packer did not seat					0.5-10.8": Quaternary Alluvium		
	80							0.5-10.8": Quaternary Alluvium		
	83.7	93.7	0.2	25	5	2053.2		0.5-10.8": Quaternary Alluvium		
			0.3	50	5			0.5-10.8": Quaternary Alluvium		
			1.5	100	5			0.5-10.8": Quaternary Alluvium		
			0.4	50	5			0.5-10.8": Quaternary Alluvium		
			0.1	25	5			0.5-10.8": Quaternary Alluvium		
			0.2	50	5			0.5-10.8": Quaternary Alluvium		
			0.1	25	5			0.5-10.8": Quaternary Alluvium		
			0.1	25	5			0.5-10.8": Quaternary Alluvium		

**Figure 10-1.—Drill hole log, DH-123, sheet 1 of 2.**

# FIELD MANUAL

## GEOLOGIC LOG OF DRILL HOLE

SHEET 2 OF 2

FEATURE LOCATION PROJECT STATE

HOLE NO. COORDS. N. E. S. GROUND ELEV. DIP (ANGLE FROM HORIZ.)

BEGIN FINISH DEPTH OF OVERBURDEN TOTAL DEPTH REBARING

DEPTH AND ELEV. OF WATER LEVEL AND DATE MEASURED LOGGED BY LOG BEARING BY

NOTES ON WATER LOSSES AND LEVELS, CASING, CEMENTING, CAVING, AND OTHER DRILLING CONDITIONS	TYPE AND SIZE OF HOLE	DEPTH (FEET)	CORRECTION (%)	PERCOLATION TESTS								CLASSIFICATION AND PHYSICAL CONDITION
				DEPTH (FEET)		LOSS (G.P.M.)		PRESSURE (P.S.I.)		RECOVERY (MIN.)		
				FROM	TO	(P.S.A.)	(P.S.I.)	17'	30'	45'	60'	
Casing and Cementing Record		98	100-	110.4	0.1	25	5					37.6-42.1'; Altered Ash Flow Buff. Reddish-brown. Fragments can be broken from core with light to moderate manual pressure, pumice fragments powder w/light finger pressure. Very Intensely Fractured. Core recovered in lengths to 0.5', mostly fragments to 0.2' core segments. This discontinuous brown clay films on all joint surfaces.
Size of Casing Interval		100			0.2	50	5					49.5-63.2'; Basalt (Tb). Gray to black. Moderately to lightly vesicular, vesicles 1/16 to 1/32". Largest 5/16" across; coated or ringed with silica. Lightly Weathered. Core scratches with moderate knife pressure, and breaks 60 to 90° to core axis with moderate hammer blow. Moderately Fractured. Recovered mostly as 0.5' to 1.3" lengths maximum 2.3'. Joint sets: (1) Dips 85° to 90°, 2' fractures cross core axis at 53.4' and 61.2', irregular surfaces with oxide stains; (2) Dips 0 to 30° spaced 0.5-2.9', irregular rough surfaces, with thin, discontinuous clay coatings.
Drilling Fluid Color and Return		120			0.3	25	5					50.351.4'; Intensely Fractured. 59.2-63.2' (100% joints). Core recovered as 0.2 to 0.3' lengths maximum length 0.5'; joints dip 10 to 35°; spaced 0.2 to 0.4' irregular, rough surfaces, joints open and filled with up to 1/4" of buff colored clay.
Interval Color & Drilled Return		89			1.9	50	5					63.2-134.3'; Jurassic Metamorphic Rock
0.0-0.5' red		100		107.0	0.0	25	5					83.2-134.3'; Amphibolite Schist (Am)
0.5-1.0' brown		100		107.0	0.0	25	5					Dark green to greenish gray, fine-grained, schistose to subschistose, composed chiefly of hornblende and quartz with calcite veinlets to 3/4" along schistosity and epidote stringers throughout.
1.0-2.0' red		100		107.0	0.0	25	5					63.2-122.3'; Lightly Weathered. Red-brown oxidation staining on most discontinuities. Core breaks along schistosity with moderate to heavy hammer blow, scratches w/heavy knife pressure.
2.0-8.0' red		100		112.4	0.1	25	5					Moderately Fractured. (60% joints, 40% cleavage) except as noted below. Core recovered in lengths to 1.8", mostly 0.6 to 1.3'. Cleavage dips 65° spaced 0.8 to 1.9'. Two joint sets noted: (1) Dip 15-30°, spaced 0.7 to 2.0', smooth, coated with oxides of Fe and Mn; (2) Dips 5-20°, normal to set (1), spaced 0.4 to 2.5', most surfaces smooth, locally minor slickensides.
8.0-9.0' red		100		112.4	0.1	25	5					87.2-101.2'; Lightly Fracture. (50% joints, 50% cleavage). Core recovered in lengths to 2.9', mostly 1.6 to 2.1'.
9.0-9.5' gray		100		112.4	0.1	25	5					111.2-117.2'; Intensely Fractured. (80% joint, 20% cleavage) Core recovered in lengths to 0.7', mostly 0.3 to 0.6'
9.5-10.0' gray		100		112.4	0.1	25	5					CONTINUED IN CENTER COLUMN.
10.0-10.5' revert. 80 blue		40		CLASSIFICATION AND PHYSICAL CONDITION CONT'D								
10.5-11.0' revert. 90 gray				117.2-120.8'; Dike. Light gray, fine-grained. Upper contact welded, dips 28°, lower contact broken, dips 35°. Lightly weathered. Solution pitting to 1/8". Core breaks with moderate hammer blow. Intensely to Moderately Fractured. (100% joints). Joints are randomly oriented and spaced; surfaces are irregular and rough; no sets discernible. Recovered mostly as 0.3 to 0.7' core lengths.								
11.0-11.5' revert. 80 blue				122.3-134.3'; Fresh. No oxidation on discontinuities. Core breaks along schistosity or across axis with heavy hammer blow; scratches with heavy knife pressure. Lightly Fractured, except as noted below								
11.5-12.0' revert. 80 blue				(55% joints, 35% cleavage). Recovered in lengths to 4.2', mostly 1.6 to 2.7' Cleavage dips 85° to 70°, spaced 1.5 to 4.5'. Joint sets noted: (1) Dips 15-35°, spaced 1.5 to 5.3', most surfaces smooth, planar; (2) Dips 10-25° normal to set (1), spaced 2.0 to 6.5', most surfaces planar and smooth, about 5% with minor slickensides, 10% healed by quartz.								
12.0-12.5' revert. 80 blue				122.4-127.7'; Intensely Fractured. (50% joints, 50% cleavage). Recovered in lengths to 0.6', mostly 0.3 to 0.5'.								
12.5-13.0' revert. 80 blue				125.1-125.8'; Shear Zone. 0.5' thick. No Recovery (72.1-125.3'). Upper contact (7), lower contact dips 62-67° (subparallel to schistosity). Consists of 70% green, moist, soft clay gouge and 30% 1/6 to 1/4" platy, slickensided, amphibolite fragments. Lower 1/2 of shear is healed by quartz calcite. Fragments break with heavy finger pressure.								

Figure 10-2

Drill Hole Log - DH-123 Sheet 2 of 2

Figure 10-1.—Drill hole log, DH-123, sheet 2 of 2.



# CORE LOGGING

STANDARD PENETRATION TEST HOLE NO. **B-102**

SHEET 1 OF 3

PROJECT .....	FEATURE .....	AREA .....	1983 SEED INVESTIGATION	STATE .....
STATION/OFFSET STA. 19+08.5 P. 8.1; 0.95		GROUND ELEV. 4396.3		ANGLE FROM HORIZ. 90.0 0000
BEGUN 9-18-83		FINISHED 9-29-83		DEPTH TO BEDROCK 123.5
DEPTH TO WATER 75.1; 11-10-83		LOGGED BY .....		REVIEWED BY .....

NOTES	STANDARD PENETRATION TEST					DEPTH TO WATER	CLASSIFICATION AND PHYSICAL CONDITION
	(DESTINATION 1-21, 4675 MANUAL)						
	NUMBER OF BLOBS	PRECISE PENETRATION	BLOBS PER FOOT				
		1 TO 2	3 TO 4	5 TO 6	7 TO 8		
DRILL EQUIPMENT HOLE BUSH MOUNTED DRILL BEAN 80 WATER PUMP	18	17.7	*			83	4293.3
DRILLER ALBERT COLETER	32	11.4	*			97	4301.5
DRILL SETUP NET UP ON LHS EDGE OF CRUST OF CAR NEAR STA. 12+00	40	15.3	*			102	
DRILLING METHOD 6.0 IN. Ø DRILLED WITH 6" HOLLOW STEEL FLIGHT AUGERS (N, 1.0, AND 6.0 IN. LINE 100% IN BIT). TOOK PR TESTS ON APPROX. 5'-0" INTERVALS. EXCEPT UPPER 100' OF CRUST, WHICH WAS 1.5" Ø. USE SPILL SPOON BARREL AND SCALE MOUNTED ON HOLE NEAR STA. 12+00. HOLLOW STEEL AUGERS SET AT 10' WATER LEVEL. FULL OF WATER DURING DRILL- ING AND TESTING.	20	18.9	*			100	
OPERATING AFTER PUMPING THE WATER 14.8 IN. Ø BIT AT 10' IN. Ø BIT AT SPOON BARREL WITH BASKET CATCHER TO RECOVER PR SAMPLE	37	25.0	*			93	
1.5" Ø BIT USED FOR SAMPLES FOR WATER ANALYSIS AND TESTS	30	19.9	*			100	
1.5" Ø BIT USED FOR SAMPLES FOR WATER ANALYSIS AND TESTS	31	16.7	*			100	
1.5" Ø BIT USED FOR SAMPLES FOR WATER ANALYSIS AND TESTS	12	24.0	*			97	
1.5" Ø BIT USED FOR SAMPLES FOR WATER ANALYSIS AND TESTS	22	22.8	*			93	
1.5" Ø BIT USED FOR SAMPLES FOR WATER ANALYSIS AND TESTS	30	15.8	*			97	
1.5" Ø BIT USED FOR SAMPLES FOR WATER ANALYSIS AND TESTS	30	18.8	*			97	
1.5" Ø BIT USED FOR SAMPLES FOR WATER ANALYSIS AND TESTS	16		*			20	
1.5" Ø BIT USED FOR SAMPLES FOR WATER ANALYSIS AND TESTS	26	18.2	*			90	
1.5" Ø BIT USED FOR SAMPLES FOR WATER ANALYSIS AND TESTS	36	27.4	*			83	
1.5" Ø BIT USED FOR SAMPLES FOR WATER ANALYSIS AND TESTS	36	21.2	*			90	
1.5" Ø BIT USED FOR SAMPLES FOR WATER ANALYSIS AND TESTS	70	18.7	*			83	
1.5" Ø BIT USED FOR SAMPLES FOR WATER ANALYSIS AND TESTS	50	20.5	*			71	
1.5" Ø BIT USED FOR SAMPLES FOR WATER ANALYSIS AND TESTS	50	18.9	*			83	
1.5" Ø BIT USED FOR SAMPLES FOR WATER ANALYSIS AND TESTS	50	17.5	*			100	
1.5" Ø BIT USED FOR SAMPLES FOR WATER ANALYSIS AND TESTS	50	17.1	*			83	
1.5" Ø BIT USED FOR SAMPLES FOR WATER ANALYSIS AND TESTS	50	24.0	*			71	
1.5" Ø BIT USED FOR SAMPLES FOR WATER ANALYSIS AND TESTS	48	19.0	*			6	
1.5" Ø BIT USED FOR SAMPLES FOR WATER ANALYSIS AND TESTS	48	50.1	*			100	
1.5" Ø BIT USED FOR SAMPLES FOR WATER ANALYSIS AND TESTS			*			87	

<b>COMMENTS:</b> AP = 6" HOLLOW STEEL FLIGHT AUGERS PR = STANDARD PENETRATION RESISTANCE TEST HB = HOLE BIT CS = CASING DEB = DEBERTS * = INDICATES WATER LEVEL ABOVE GROUND SURFACE ACD = HYDROCLORIC ACID  NOTE: WEIGHT OF DROP HAMMER IS 140.00 LBS; HEIGHT OF ENTIRE HAMMER ASSEMBLY IS 100.78 LBS.	<b>EXPLANATIONS:</b> 4293.3 4301.5 4293.3 4297.8
--	--

FEATURE .....

**Figure 10-2.—Drill hole log, B-102, for Standard Penetration Test, sheet 1 of 3.**

# FIELD MANUAL

## STANDARD PENETRATION TEST HOLE NO. B-102

SHEET 2 OF 3

PROJECT		FEATURE		AREA		1983 SEED INVESTIGATION		STATE					
STATION/OFFSET		STA. 10+02.7, 8.1' U/S		GROUND ELEV.		3796.3		ANGLE FROM HORIZ.		W. 0.8 DOWN			
BEGIN		9-19-83		FINISHED		9-29-83		DEPTH TO BEDROCK		103.5			
DEPTH TO WATER		70.4		11-10-83		LOGGED BY				TOTAL DEPTH		114.0	
NOTES		STANDARD PENETRATION TEST (DESIGNATION E-2; EARTH MANUAL)				RECEIVED BY		CLASSIFICATION AND PHYSICAL CONDITION					
				BLOWS PER FOOT									
				140 LB. HAMMER-30 IN. DROP	10 20 30 40								
<p>AND FAST, ALTERNATING SOIL.</p> <p>CASING RECORD</p> <p>DATE SZ HOLE CS</p> <p>8-18 AP 15.0 15.0</p> <p>8-20 AP 45.5 44.0</p> <p>8-21 " 45.5 44.0</p> <p>8-22 " 45.5 44.0</p> <p>8-23 " 45.5 44.0</p> <p>8-24 " 45.5 44.0</p> <p>8-25 " 45.5 44.0</p> <p>8-26 " 45.5 44.0</p> <p>8-27 " 114.0 103.9</p> <p>FLUID RETURN</p> <p>0 DOWN " NO FLUID</p> <p>USED</p> <p>WATER D: 1.022</p> <p>100.0-114.0: 1.021</p> <p>100.0-114.0: 1.022</p> <p>FLUID COLOR</p> <p>0 DOWN " NO FLUID</p> <p>USED</p> <p>WATER D: 1.022</p> <p>100.0-114.0: 1.021</p> <p>100.0-114.0: 1.022</p> <p>FLUID LEVEL DURING DRILLING</p> <p>DEPTH FLUID LEVEL</p> <p>DATE</p> <p>8-20 15.0 0.1</p> <p>8-21 45.5 0.1</p> <p>8-22 45.5 0.1</p> <p>8-23 45.5 0.1</p> <p>8-24 45.5 0.1</p> <p>8-25 45.5 0.1</p> <p>8-26 45.5 0.1</p> <p>8-27 114.0 103.9</p> <p>WATER LEVEL AFTER DRILLING</p> <p>DATE WATER ELEVATION</p> <p>8-20 96.9 4987.4</p> <p>10-5 96.8 4987.1</p> <p>10-5 96.8 4979.9</p> <p>10-14 74.2 4971.8</p> <p>10-21 75.5 4973.8</p> <p>10-28 74.4 4972.2</p> <p>10-30 74.4 4972.2</p> <p>10-31 70.4 4976.0</p> <p>11-1 70.3 4976.0</p> <p>11-4 70.3 4976.0</p> <p>11-10 70.4 4976.0</p> <p>DENSITY WATER TESTS NONE TAKEN.</p> <p>DRILLING TIME 48 HOURS</p> <p>TEMPORARY</p> <p>HOLE COMPLETION</p> <p>BACKFILLED HOLE WITH REINFORCED CONCRETE FROM 105.2 TO 114.0</p> <p>BACKFILLED WITH RANDOM SAND AND GRAVEL FROM 103.9 TO 105.2</p> <p>INSTALLER'S T.O. PWC TO TEST AT LOWER 15.0 RECORDED WITH 0.500' SLOTS</p> <p>FINISH</p> <p>TO BE COMPLETED DURING 1984 FIELD SEASON</p> <p>PURPOSE OF HOLE TO DETERMINE THE LIQUIDATION POTENTIAL OF THE ENHANCEMENT AND FOUNDATION MATERIALS.</p>													
COMMENTS:						EXPLANATIONS:							
<p>AP = 8" HOLLOW-STEM FLIGHT AUGERS</p> <p>PM = STANDARD PENETRATION RESISTANCE TEST</p> <p>MB = ROCK BIT CS = CASING</p> <p>DED = DECIDUES SZ = SIZE OF CASING</p> <p>+ = INDICATES WATER LEVEL ABOVE GROUND SURFACE</p> <p>ACID = HYDROCHLORIC ACID</p> <p>NOTE: HEIGHT OF DROP HAMMER IS 130.95 LBS; HEIGHT OF ENTIRE HAMMER ASSEMBLY IS 180.78 LBS.</p>													

FEATURE: \_\_\_\_\_ AREA: 1983 SEED INVESTIGATION SHEET 2 OF 3 HOLE NO. B-102

**Figure 10-2.—Drill hole log, B-102, for Standard Penetration Test, sheet 2 of 3.**

# CORE LOGGING

**STANDARD PENETRATION TEST HOLE NO. B-102**

SHEET 3 OF 3

PROJECT..... FEATURE.....		AREA..... 1963 SEED INVESTIGATION.....		STATE.....	
STATION/OFFSET STA. 17-02.2, B-11 U/S.....		GROUND ELEV. 434.3 ANGLE FROM HORIZ. 90.0 DOWN.....			
BEGIN 8-18-83..... FINISHED 9-28-83.....		DEPTH TO BEDROCK 103.5.....		TOTAL DEPTH..... 171.0 BEARING.....	
DEPTH TO WATER TO N) 11-12-83.....		LOGGED BY.....		REVIEWED BY.....	
NOTES	STANDARD PENETRATION TEST (DESTINATION C-01, EARTH MANUAL)			CLASSIFICATION (DESTINATION)	
	NUMBER OF BLOWS IN FOOT	RESISTANCE INDEX	BLOWS PER FOOT	CLASSIFICATION	PHYSICAL CONDITION
	10	25	30	40	
CLASSIFICATION AND PHYSICAL CONDITION CONTINUED					
<p>110</p> <p>200</p> <p>300</p> <p>400</p> <p>500</p> <p>600</p> <p>700</p> <p>800</p> <p>900</p> <p>1000</p>					
<p>WITH LOW PLASTICITY AND QUICK DILATANCY. MAXIMUM SIZE 35MM. MOIST. BROWN. SCATTERED DILATED ORGANIC FRAGMENTS. METROGENEUS. WITH IRREGULAR INCLUSIONS OF BUFF VOLCANIC ASH. COMPRES. WITH MODERATE TO STRONG MANUAL PRESSURE. NO REACTION TO H<sub>2</sub>O.</p> <p>95 0-50 " SILTY SAND. APPROX. 50% FINES. COARSE TO FINE. HARD. ANGLAR TO SUB-ROUNDED SAND. FINE CLAY TO FINE SAND. ANGLAR TO SUBROUNDED GRAVEL. 15% FINES WITH LOW PLASTICITY AND QUICK DILATANCY. MAXIMUM SIZE 20MM. MOIST. BROWN. METROGENEUS. COMPRES. WITH MODERATE MANUAL PRESSURE. NO REACTION TO ACID (SM). HARD. ANGLAR TO SUB-ROUNDED SAND. FINE CLAY TO FINE SAND. ANGLAR TO SUBROUNDED GRAVEL. 15% FINES WITH LOW PLASTICITY AND QUICK DILATANCY. MAXIMUM SIZE 35MM. MOIST. BROWN. METROGENEUS. COMPRES. WITH MODERATE MANUAL PRESSURE. NO REACTION TO ACID (SM). 90 0-50 " SILTY SAND. APPROX. 50% FINES. COARSE TO FINE. HARD. ANGLAR TO SUBROUNDED GRAVEL. 15% FINES WITH LOW PLASTICITY AND QUICK DILATANCY. MAXIMUM SIZE 20MM. MOIST. BROWN. METROGENEUS. COMPRES. WITH MODERATE MANUAL PRESSURE. NO REACTION TO ACID (SM). 85 0-50 " SILTY SAND. APPROX. 50% FINES. COARSE TO FINE. HARD. ANGLAR TO SUBROUNDED GRAVEL. 15% FINES WITH LOW PLASTICITY AND QUICK DILATANCY. MAXIMUM SIZE 20MM. MOIST. BROWN. METROGENEUS. COMPRES. WITH MODERATE MANUAL PRESSURE. NO REACTION TO ACID (SM). 80 0-50 " SILTY SAND. APPROX. 50% FINES. COARSE TO FINE. HARD. ANGLAR TO SUBROUNDED GRAVEL. 15% FINES WITH LOW PLASTICITY AND QUICK DILATANCY. MAXIMUM SIZE 20MM. MOIST. BROWN. METROGENEUS. COMPRES. WITH MODERATE MANUAL PRESSURE. NO REACTION TO ACID (SM). 75 0-50 " SILTY SAND. APPROX. 50% FINES. COARSE TO FINE. HARD. ANGLAR TO SUBROUNDED GRAVEL. 15% FINES WITH LOW PLASTICITY AND QUICK DILATANCY. MAXIMUM SIZE 20MM. MOIST. BROWN. METROGENEUS. COMPRES. WITH MODERATE MANUAL PRESSURE. NO REACTION TO ACID (SM). 70 0-50 " SILTY SAND. APPROX. 50% FINES. COARSE TO FINE. HARD. ANGLAR TO SUBROUNDED GRAVEL. 15% FINES WITH LOW PLASTICITY AND QUICK DILATANCY. MAXIMUM SIZE 20MM. MOIST. BROWN. METROGENEUS. COMPRES. WITH MODERATE MANUAL PRESSURE. NO REACTION TO ACID (SM). 65 0-50 " SILTY SAND. APPROX. 50% FINES. COARSE TO FINE. HARD. ANGLAR TO SUBROUNDED GRAVEL. 15% FINES WITH LOW PLASTICITY AND QUICK DILATANCY. MAXIMUM SIZE 20MM. MOIST. BROWN. METROGENEUS. COMPRES. WITH MODERATE MANUAL PRESSURE. NO REACTION TO ACID (SM). 60 0-50 " SILTY SAND. APPROX. 50% FINES. COARSE TO FINE. HARD. ANGLAR TO SUBROUNDED GRAVEL. 15% FINES WITH LOW PLASTICITY AND QUICK DILATANCY. MAXIMUM SIZE 20MM. MOIST. BROWN. METROGENEUS. COMPRES. WITH MODERATE MANUAL PRESSURE. NO REACTION TO ACID (SM). 55 0-50 " SILTY SAND. APPROX. 50% FINES. COARSE TO FINE. HARD. ANGLAR TO SUBROUNDED GRAVEL. 15% FINES WITH LOW PLASTICITY AND QUICK DILATANCY. MAXIMUM SIZE 20MM. MOIST. BROWN. METROGENEUS. COMPRES. WITH MODERATE MANUAL PRESSURE. NO REACTION TO ACID (SM). 50 0-50 " SILTY SAND. APPROX. 50% FINES. COARSE TO FINE. HARD. ANGLAR TO SUBROUNDED GRAVEL. 15% FINES WITH LOW PLASTICITY AND QUICK DILATANCY. MAXIMUM SIZE 20MM. MOIST. BROWN. METROGENEUS. COMPRES. WITH MODERATE MANUAL PRESSURE. NO REACTION TO ACID (SM). 45 0-50 " SILTY SAND. APPROX. 50% FINES. COARSE TO FINE. HARD. ANGLAR TO SUBROUNDED GRAVEL. 15% FINES WITH LOW PLASTICITY AND QUICK DILATANCY. MAXIMUM SIZE 20MM. MOIST. BROWN. METROGENEUS. COMPRES. WITH MODERATE MANUAL PRESSURE. NO REACTION TO ACID (SM). 40 0-50 " SILTY SAND. APPROX. 50% FINES. COARSE TO FINE. HARD. ANGLAR TO SUBROUNDED GRAVEL. 15% FINES WITH LOW PLASTICITY AND QUICK DILATANCY. MAXIMUM SIZE 20MM. MOIST. BROWN. METROGENEUS. COMPRES. WITH MODERATE MANUAL PRESSURE. NO REACTION TO ACID (SM). 35 0-50 " SILTY SAND. APPROX. 50% FINES. COARSE TO FINE. HARD. ANGLAR TO SUBROUNDED GRAVEL. 15% FINES WITH LOW PLASTICITY AND QUICK DILATANCY. MAXIMUM SIZE 20MM. MOIST. BROWN. METROGENEUS. COMPRES. WITH MODERATE MANUAL PRESSURE. NO REACTION TO ACID (SM). 30 0-50 " SILTY SAND. APPROX. 50% FINES. COARSE TO FINE. HARD. ANGLAR TO SUBROUNDED GRAVEL. 15% FINES WITH LOW PLASTICITY AND QUICK DILATANCY. MAXIMUM SIZE 20MM. MOIST. BROWN. METROGENEUS. COMPRES. WITH MODERATE MANUAL PRESSURE. NO REACTION TO ACID (SM). 25 0-50 " SILTY SAND. APPROX. 50% FINES. COARSE TO FINE. HARD. ANGLAR TO SUBROUNDED GRAVEL. 15% FINES WITH LOW PLASTICITY AND QUICK DILATANCY. MAXIMUM SIZE 20MM. MOIST. BROWN. METROGENEUS. COMPRES. WITH MODERATE MANUAL PRESSURE. NO REACTION TO ACID (SM). 20 0-50 " SILTY SAND. APPROX. 50% FINES. COARSE TO FINE. HARD. ANGLAR TO SUBROUNDED GRAVEL. 15% FINES WITH LOW PLASTICITY AND QUICK DILATANCY. MAXIMUM SIZE 20MM. MOIST. BROWN. METROGENEUS. COMPRES. WITH MODERATE MANUAL PRESSURE. NO REACTION TO ACID (SM). 15 0-50 " SILTY SAND. APPROX. 50% FINES. COARSE TO FINE. HARD. ANGLAR TO SUBROUNDED GRAVEL. 15% FINES WITH LOW PLASTICITY AND QUICK DILATANCY. MAXIMUM SIZE 20MM. MOIST. BROWN. METROGENEUS. COMPRES. WITH MODERATE MANUAL PRESSURE. NO REACTION TO ACID (SM). 10 0-50 " SILTY SAND. APPROX. 50% FINES. COARSE TO FINE. HARD. ANGLAR TO SUBROUNDED GRAVEL. 15% FINES WITH LOW PLASTICITY AND QUICK DILATANCY. MAXIMUM SIZE 20MM. MOIST. BROWN. METROGENEUS. COMPRES. WITH MODERATE MANUAL PRESSURE. NO REACTION TO ACID (SM). 5 0-50 " SILTY SAND. APPROX. 50% FINES. COARSE TO FINE. HARD. ANGLAR TO SUBROUNDED GRAVEL. 15% FINES WITH LOW PLASTICITY AND QUICK DILATANCY. MAXIMUM SIZE 20MM. MOIST. BROWN. METROGENEUS. COMPRES. WITH MODERATE MANUAL PRESSURE. NO REACTION TO ACID (SM). 0 0-50 " SILTY SAND. APPROX. 50% FINES. COARSE TO FINE. HARD. ANGLAR TO SUBROUNDED GRAVEL. 15% FINES WITH LOW PLASTICITY AND QUICK DILATANCY. MAXIMUM SIZE 20MM. MOIST. BROWN. METROGENEUS. COMPRES. WITH MODERATE MANUAL PRESSURE. NO REACTION TO ACID (SM).</p>					
<p>11.37' BOTTOM OF HOLE.</p>					
COMMENTS:			EXPLANATIONS:		
<p>AP = 8" WELDON-STEIN FLIGHT AUGERS          PR = STANDARD PENETRATION RESISTANCE TEST          RB = ROCK BIT          CS = CASING          DES = DEBRIS          + = INDICATES WATER LEVEL ABOVE GROUND SURFACE          ACID = HYDROCHLORIC ACID</p> <p>NOTE: HEIGHT OF DROP HAMMER IS 170.0 LB. (WEIGHT OF ENTIRE HAMMER ASSEMBLY IS 180.75 LB.).</p>					

FEATURE..... AREA..... 1963 SEED INVESTIGATION..... SHEET 3 OF 3 HOLE NO. B-102

**Figure 10-2.—Drill hole log, B-102, for Standard Penetration Test, sheet 3 of 3.**

## FIELD MANUAL

hole number, location, coordinates, elevation, bearing and plunge of hole, dates started and completed, and the name(s) of the person(s) responsible for logging and review. Locations should preferably be in coordinates unless station and offset are all that is available.

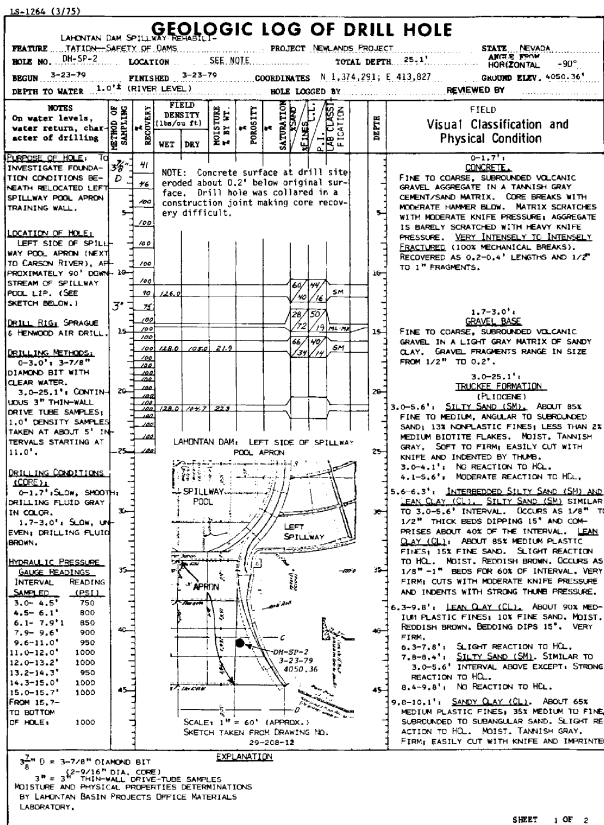
Provide both coordinates and station and offset if available. The dip or plunge of the hole can be the angle from horizontal or from vertical, but the reference point should be noted on the log. Spaces for depth to bedrock and water levels are also provided. All this information is important and should not be omitted. Below the heading, the body of the log form is divided into a series of columns covering the various kinds of information required according to the type of exploratory hole.

### **Data Required for the "Drilling Notes" Column**

Data for the left-hand column of all drill hole logs are similar whether for large-diameter sampling, Standard Penetration Tests, rock core, or push-tube sampling logs. These data are field observations and information provided by the driller on the Daily Drill Reports. Examples are provided for some of these data headings; a suggested guideline and preferred order is presented in the following paragraphs but may differ depending on the purpose and type of exploration. Headers for data can indicate whether depths are in feet (ft) or meters (m), eliminating the need to repeat "ft" or "m" for each interval entry. An example of the Drilling Notes column is provided on figures 10-1 through 10-4.

**General Information.**—This includes headers and data for the hole purpose, the setup or site conditions, drillers, and drilling and testing equipment used.

# CORE LOGGING



**Figure 10-3.—Drill hole log, DH-SP-2, sheet 1 of 2.**

# FIELD MANUAL

GEOLOGIC LOG OF DRILL HOLE—CONTINUATION SHEET							
FEATURE: LAHONTAN DAM SPILLWAY REPAIR/RECON. PROJECT, NEVADA PROJECT, NEVADA							
HOLE NO.: DH-SP-2	TATION - SAFETY OF DAMS						
SHEET 2 OF 2							
NOTES (CONTINUED)	FIELD VISUAL CLASSIFICATION AND PHYSICAL CONDITION (CONTINUED)						
<p><b>CASING RECORD:</b>            SIZE: 4"</p> <table style="width: 100%; border-collapse: collapse;"> <tr> <td style="width: 50%; border-bottom: 1px solid black;">INTERVAL DRILLED OR SHAFTED:</td> <td style="width: 50%; border-bottom: 1px solid black;">CASING DEPTH:</td> </tr> <tr> <td style="border-bottom: 1px solid black;">0.0-3.0'</td> <td style="border-bottom: 1px solid black;">0.0'</td> </tr> <tr> <td style="border-bottom: 1px solid black;">3.0-25.1'</td> <td style="border-bottom: 1px solid black;">3.0'</td> </tr> </table> <p><b>HOLE CONDITION:</b> LEFT HOLE OPEN. COULD NOT BACKFILL DUE TO RISING RIVER LEVEL.</p>	INTERVAL DRILLED OR SHAFTED:	CASING DEPTH:	0.0-3.0'	0.0'	3.0-25.1'	3.0'	<p>9.8-10.1' (CONTINUED); WITH MODERATE THUMB PRESSURE.</p> <p>10.1-10.4': <u>CLAYEY SAND (SC)</u>. ABOUT 75% FINE TO MEDIUM, SUBANGULAR TO SUBROUNDED SAND; 25% MEDIUM PLASTIC FINES. MODERATE TO STRONG REACTION TO HCL. MOIST. TANNISH GRAY. FIRM; CUTS EASILY WITH KNIFE.</p> <p>10.4-10.6': <u>SANDY CLAY (CL)</u>. SIMILAR TO 9.8-10.1' INTERVAL.</p> <p>10.6-11.0': <u>LEAN CLAY (CL)</u>. SIMILAR TO 6.3-9.8' INTERVAL.</p> <p>11.0-25.1': <u>CLAYEY SAND (SC-SM)</u>. ABOUT 70% MEDIUM TO FINE, SUBANGULAR TO SUBROUNDED SAND; 30% LOW TO MEDIUM PLASTIC FINES. SCATTERED AREAS GIVE MODERATE REACTION TO HCL. MOIST. TAN. FIRM; CUTS EASILY WITH KNIFE AND INDENTS WITH MODERATE THUMB PRESSURE. WITH CONTINUED WORKING, PERCENTAGE OF FINES INCREASES TO APPROXIMATELY 40% APPARENTLY DUE TO BREAKDOWN OF CLAYSTONE GRAINS OR WEATHERED VOLCANIC MATERIAL.</p> <p>13.7-15.0': <u>SANDY CLAY (CL-M)</u>. ABOUT 65% LOW TO MEDIUM PLASTIC FINES; 35% FINE TO MEDIUM, SUBANGULAR TO SUBROUNDED SAND. NO REACTION TO HCL. MOIST. BROWN. VERY FIRM; CUTS WITH MODERATE KNIFE PRESSURE, INDENTS WITH HEAVY THUMB PRESSURE.</p> <p>17.1-18.6': <u>CLAYEY SAND—POORLY GRADED SAND (SC-SP)</u>. ABOUT 90% MEDIUM TO COARSE, SUBANGULAR TO SUBROUNDED SAND; 10% MEDIUM PLASTIC FINES. OCCASIONAL MODERATE REACTION TO HCL. MOIST, GREENISH TAN. FIRM; CUTS EASILY WITH KNIFE, IMPRINTED WITH MODERATE THUMB PRESSURE.</p> <p>18.6-18.8': <u>SANDY CLAY (CL)</u>. ABOUT 75% MEDIUM PLASTIC FINES; 25% MEDIUM TO FINE, SUBANGULAR TO SUBROUNDED SAND. NO REACTION TO HCL. MOIST. BROWN. VERY FIRM; CUTS WITH MODERATE KNIFE PRESSURE, IMPRINTED WITH MODERATE TO STRONG THUMB PRESSURE.</p> <p>21.1-21.6': <u>CLAYEY SAND (SC)</u>. ABOUT 85% MEDIUM, SUBANGULAR TO SUBROUNDED SAND; 15% MEDIUM PLASTIC FINES. NO REACTION TO HCL. MOIST. TAN. SOFT; CRUMBLES WITH LIGHT MANUAL PRESSURE, INDENTS WITH LIGHT THUMB PRESSURE.</p> <p>24.6-24.7': <u>SANDY CLAY (CL)</u>. SIMILAR TO 18.6-18.8' INTERVAL.</p>
INTERVAL DRILLED OR SHAFTED:	CASING DEPTH:						
0.0-3.0'	0.0'						
3.0-25.1'	3.0'						
	SHEET 2 OF 2						
FEATURE: LAHONTAN DAM	PROJECT: NEVADA PROJECT, NEVADA						
	HOLE NUMBER: DH-SP-2						

**Figure 10-3.—Drill hole log, DH-SP-2, sheet 2 of 2.**

# CORE LOGGING

## GEOLOGIC LOG OF DRILL HOLE

FEATURE		Any Dam		PROJECT		Western States		STATE		Utah				
HOLE NO.		GPS-107-2		LOCATION		See Notes		GROUND ELEVATION		249.0'				
TOTAL DEPTH		48.5'		COORDINATES		N 2,770,481; E 1,248,710		COMPLETED		5-13-62				
DEPTH TO WATER		See Notes, Sheet 2		BEGIN		5-1-62		LOGGED BY		REVIEWED BY				
ANGLE FROM HORIZONTAL		90°		BEARING		---								
NOTES On water table levels, water return, character of drilling	Type and Size of Hole	RECOVERY	FIELD MOISTURE	FIELD WETNESS	FIELD DRYNESS	FIELD PLASTICITY	FIELD LIQUIDITY	PENETRATION RESISTANCE				DEPTH	VISUAL CLASSIFICATION AND PHYSICAL CONDITION	
								Blows per 65 ft	ACTUAL	CL	SC			
Purpose of Hole: To perform penetration resistance tests for materials and dynamic properties data and to install one PDP piezometer at Gal-Panchoe contact.	7" FA	O											SUMMARY LOG: 0.0-2.4': FILL. Sandy Clay with gravel. 2.5-36.5': QUATERNARY ALLUVIUM. Heavily Sandy Clay and Lean Clay (CL) with some Clayey Gravel (GC) at top and occasional Silty Sand (SM) and Clayey Sand (SC).	
														36.5-48.5': PANCHOE GROUP (Cretaceous Marine Sedimentary Rocks) Silty Sandstone and Sandstone.
Location of Hole: Station 107+01.2, offset 911.4' right of dam centerline.	SPT	87	1/8	32	26	8	19							
Drillers: B. Lowtree and F. Smith	SPT	80	1/5	32	23	8	0							
Drilling Equipment: Mobile B-61	SPT	73	1/8	30	23	8	8							
Drilling Methods: 0.0-0.0': Augered with 7" flights.	SPT	67	1/8	30	26	8	5							
5.0-44.0': Standard penetration tests (SPT) taken at approximately 1' intervals followed by cleanout with 3-5/8" tri-cone rock bit advanced to 1.5' below the previous SPT interval. Details of SPT test procedures in explanation below.	SPT	87	21/8	32	26	8	4							
44.0-48.5': 3WD-3 diamond drilling with 4.5" core barrel and split inner barrel.	SPT	81	1/8	32	26	8	12							
Drilling and SPT tests performed using "thick-w-7th" and/or "instapak" polymer reversible drilling fluid.	SPT	87	1/8	32	26	8	35							
Drilling Conditions: Iron rockbit and cored intervals only	SPT	80	2/8	32	26	8	14							
0-22.4': Generally smooth, easy; 10.8' contact light green to blue-gray color.	SPT	80	2/8	32	26	8	72							
22.9-44.0': Intermittently rough to moderately rough.	SPT	67	2/8	32	26	8	37							
44.0-48.5': Generally hard and smooth (3WD-3 core drilling).	SPT	100	1/8	NP	NP	NP	NP							
The SPT tests were conducted using the following equipment:	SPT	100	1/8	NP	NP	NP	NP							
1) 140 lb Mobile Safety Hammer with 30" length 3/4", with 80.0" drop, diameter 4-3/8"	SPT	100	1/8	NP	NP	NP	NP							
2) Diamond Drill BH upset drill rods, approx. 42.3 lbs/10 feet.	SPT	100	1/8	NP	NP	NP	NP							
3) Penetration sampler with split inner barrel; 2.95' long, 1 1/2" I.D., 2" O.D.	SPT	100	1/8	NP	NP	NP	NP							
4) Rope and Cathode system: a) Mast sheave 7.6" dia. b) Sheave height from Cathode, 29.35' (29'4.5") c) Cathode 8.0" diameter. d) 1" dia. new manilla rope; 2 wraps on Cathode.	SPT	100	1/8	NP	NP	NP	NP							

FEATURE: Figure 11-10-11, Sheet 1 of 3 PROJECT: \_\_\_\_\_ HOLE NO. \_\_\_\_\_ SPT-107-2

**Figure 10-4.—Drill hole log, SPT-107-2, sheet 1 of 3.**

# FIELD MANUAL

GEOLOGIC LOG OF DRILL HOLE—CONTINUATION SHEET			
FEATURE	PROJECT		SHEET 2 OF 3
HOLE NO.	SPT-107-2		
NOTES (Continued)	VISUAL CLASSIFICATION AND PHYSICAL CONDITION (Continued)		
<b>Estimated Drilling Fluid Return and color:</b> 0-48.5', 90% to 100% reddish brown	11.0-12.2' (Continued): mottled with red oxide and gray-green reduced material. No reaction with HCl.		
<b>Caving Conditions</b> None.	12.2-12.5': No Recovery.		
<b>Casing and cementing Record</b>	12.5-14.0': Rockbit.		
<b>size Depth Casing Interval Drilled</b>	14.0-15.1': Silty Sand (SM). Similar to 11.0-12.2' except: 60% sand and 40% fines with no to low plasticity; coarse sand size increased.		
7" 5.0' 5.0-48.5'	15.1-15.5': No Recovery.		
	15.5-17.0': Rockbit.		
	17.0-17.7': Clayey Gravel (GC-SC). Approx. 40% fine, hard, subrounded gravel; approx. 40% fine to coarse sand; approx. 20% fines with low plasticity; maximum size 10 mm. Soft; wet (due to mud contamination); brown to gray.		
	17.7-18.0': Sandy Clay (CL). Approx. 70% fines with low plasticity; approx. 25% size to medium with traces of coarse sand; approx. 5% fine, hard, subrounded gravel; maximum size 10 mm. Very soft; moist; gray with red oxide mottling. No reaction with HCl.		
ement only used in piezometer installation from 21.0' to surface.	18.0-18.5': No Recovery.		
	18.5-20.0': Rockbit.		
<b>Completion</b> Pulled flights. Installed one porous tube piezometer with a tip elevation of 210.0' (see diagram on Sheet 3). Finished hole with 4" standpipe and screw cap with 2.5' stickup for piezometer access. Set a 4x4' subwood post for future hole identification. Hole was not surveyed.	20.0-21.3': Silty Sand (SM). Approx. 65% predominantly fine to traces of coarse sand; approx. 35% fines with no to low plasticity; trace fine, hard, angular to subangular gravel, partially white quartz; maximum size 10 mm. Very soft; wet (due to mud contamination); blue-gray. No to weak reaction with HCl.		
	21.3-21.5': No Recovery.		
	21.5-23.0': Rockbit.		
<b>Depth to Water (below ground surface):</b>	23.0-23.7': Silty Sand (SM). Approx. 50% fine to coarse sand; approx. 25% nonplastic fines; approx. 25% fine to coarse, hard, subangular gravel; traces of white quartz; maximum size 10 mm. Soft; moist; blue-green.		
Date	Piezometer 107-2		
5-12-62	14.4'		
5-19-62	15.4'		
5-24-62	15.7'		
6- 1-62	16.3'		
6- 7-62	16.4'		
6-10-62	16.4'		
6-16-62	16.5'		
6-21-62	16.9'		
6-28-62	16.0'		
7-12-62	17.2'		
<b>Time Required to Complete Hole:</b>	24.5-26.0': Rockbit.		
Hole set up: 5 hours	26.0-27.3': Lean Clay (CL). Approx. 60% fines with medium plasticity; approx. 40% fine sand; maximum size fine sand. Firm; moist; blue with extensive white cementation due to calcium carbonate. Strong hydrogen sulfide odor. Strong reaction with HCl.		
Drilling: 11 hours	27.3-27.5': No Recovery.		
Downtime: 8 hours	27.5-29.0': Rockbit.		
	29.0-29.3': Lean Clay (CL). Similar to 23.7-24.3' interval except: Firm, with extensive white cementation due to calcium carbonate. Strong hydrogen sulfide odor. Strong reaction with HCl.		
	29.3-33.2': Lean Clay (CL). Approx. 35% fines with medium plasticity; approx. 25% fine sand; maximum size fine sand. Soft; moist; blue with white calcium carbonate stains and occasional carbonate-cemented, firm to hard areas. Strong hydrogen sulfide odor. No to strong (in white cementation) reaction with HCl.		
	30.2-30.5': No Recovery.		
	30.5-32.3': Rockbit.		
	32.3-33.5': Sandy Clay (CL). Approx. 63% fines with medium plasticity; approx. 35% predominantly fine sand; maximum size fine sand. Soft to very firm with depth in tube; moist to dry with depth. Dark blue with white and gray, calcium carbonate cement; trace calcareous concretionary material. Very strong reaction with HCl.		
	33.5-33.8': No Recovery.		
	33.8-35.0': Rockbit.		
	35.0-36.0': Sandy Clay (CL). Approx. 70% fines with medium plasticity; approx. 30% fine sand; maximum size fine sand. Firm; dry to moist; blue with extensive gray calcium carbonate mottling. Very strong reaction with HCl.		
	36.0-36.5': No Recovery.		
	36.5-48.5': SANDY CLAY (CL) (Cretaceous Marine Sedimentary Rocks)		
	36.5-38.0': Rockbit.		
	38.0-39.0': Sandy Claystone (ST). Recovered as Sandy to Silty Clay (CL-ML), with approx. 20% fines with no to low plasticity; and very firm with some cemented sandy claystone (?) fragments easily broken with fingers. Dry to moist; blue with gray calcium carbonate mottling. Very strong reaction with HCl. Hydrogen sulfide odor. May include some in-place, altered rock.		

FEATURE: Figure 11-10-12, Sheet 2 of 3

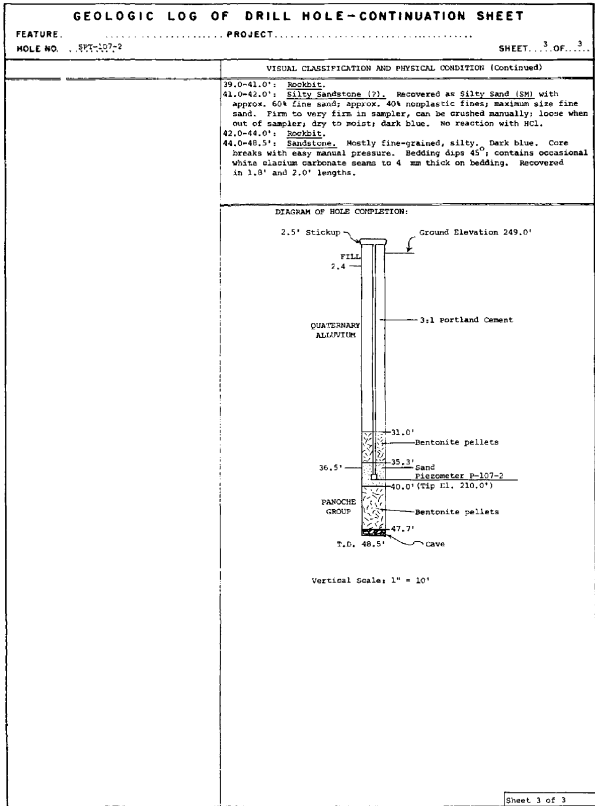
PROJECT:

HOLE NO. SPT-107-2

**Figure 10-4.—Drill hole log, SPT-107-2, sheet 2 of 3.**



# CORE LOGGING



**Figure 10-4.—Drill hole log, SPT-107-2, sheet 3 of 3.**

## FIELD MANUAL

**1. Purpose of hole** — Includes reason for drilling the hole, such as foundation investigation, materials investigation, instrumentation, sampling, or testing.

**2. Drill site or setup** — Includes general physical description of the location of the drill hole. Information on unusual setups, such as adjacent to a stream, or drilled from a barge, gallery, or adit, may help understand the unusual conditions.

**3. Drillers** — Names of drillers may be significant for reference or for evaluating or interpreting core losses, drilling rates, and other drilling conditions.

### **4. Drilling equipment** —

- Drill rig (make and model)
- Core barrel(s), tube(s), special samplers (type and size)
- Bits (type and size)
- Drill rods (type and size)
- Collar (type)
- Water test equipment (rod or pipe size, hose size, pump type and capacity, and relative position and elevation of pressure gauges or transducers), packers (type—mechanical or pneumatic)

Example: Skid-mounted Sprague and Henwood Model 250. NWD3 bottom discharge bit with a 5-ft (1.5-m), split-tube inner barrel. 5-ft (1.5-m) NW rods. Water tested with NX pneumatic

## CORE LOGGING

packer No. 12 with 1-1/4-inch (in) (32-millimeter [mm]) pipe, Bean pump with 35-gallons per minute (gal/min) (159 liters per minute) maximum volume, and 1-in (25-mm) water meter. (Water testing equipment can be a separate heading if desired.)

**Drilling Procedures and Conditions.**—These headers and data should include methods, conditions, driller's comments, and records for water losses, caving, or casing.

**1. Drilling methods** — Synopsis of drilling, sampling, and testing procedures, including procedures and pressures for drive or push tubes used through the various intervals of the hole.

**2. Drilling conditions and driller's comments** —

Note by interval the relative penetration rate and the action of the drill during this process (i.e., 105.6-107.9: drilled slowly, moderate blocking off, hole advancing 15 minutes per foot [.3 meter]). Unusual drilling conditions should be summarized. Changes in drilling conditions may indicate differences in lithology, weathering, or fracture density. The geologist needs to account for variations in driller's descriptions; each driller may describe similar conditions with different adjectives or percentage estimates. Any other comments relative to ease or difficulty of advancing or maintaining the hole should be noted by depth intervals. Drillers' comments need to adequately describe conditions encountered while advancing the hole. Statements such as "normal drilling" or "no problems encountered" are not useful.

Differences in drilling speeds, pressures, and penetration rates may be related to the relative

## FIELD MANUAL

hardness and density of materials. Abrupt changes in drilling time may identify lithologic changes or breaks and also may pinpoint soft or hard interbeds within larger units. Often, these may be correlated with geophysical logs. If the driller provides useful and accurate records of drilling conditions and procedures, an accurate determination of the top and bottom of key marker horizons can be made even without core.

Drilling progress should be recorded while drilling; recovery can be improved by relating recovery to optimum pressures and speeds, as well as providing data for interpretation. For each run, the driller should record the time when starting to drill and when stopping to come out of the hole. Most of these drilling progress data are qualitative rather than quantitative values. Controlling factors are not only the type of materials encountered but also may be mechanical or driller variables. These variables may include type and condition of the bit, rotation speed, drilling fluid pressure, etc. THE PURPOSE OF THE BORING IS TO OBTAIN THE HIGHEST QUALITY CORE AND MOST COMPLETE RECOVERY AND INFORMATION, NOT JUST FEET PER HOUR OR SHIFT.

**3. Drilling fluid** — Type and where used (including drilling fluid additives). This may be combined with or discussed under the heading, drilling methods.

**4. Drilling fluid return** — Include interval/percent return. Drilling fluid return may be combined with color.

**5. Drill fluid color** — Include interval/color.

## CORE LOGGING

**6. Caving conditions** — Intervals of cave with appropriate remarks about the relative amount of caving are to be noted. When possible, report the actual caving interval rather than the depth of the hole.

**7. Casing record** — Casing depth is the depth of casing at the start of the drilled interval (see the example below).

**8. Advancement (push-tube or Standard Penetration Test (SPT) applications)** — Include depth/ interval sampled.

**9. Cementing record** — Note all intervals cemented and if intervals were cemented more than once. This information may be combined with the casing record, as shown below:

Example of casing and cementing record:

Interval drilled (feet)	Size (inch)	Casing depth (feet)
0.0-2.3	6 Cs	0.0
2.3-4.5	6 Cs	2.0
4.5-9.2	6 Cs	4.0
9.2-15.3	NxCs	8.0
15.3-18.7	NxCs	15.0
18.7-33.2	Cmt	12.1-18.7 Cmt

**Hole Completion and Monitoring Data.**—Data shown in this section of the left-hand column include hole completion, surveys, water levels, drilling rates or time, and reason for hole termination.

## FIELD MANUAL

### **1. Borehole survey data** — Include if obtained.

Example of survey data:

Depth	Bearing	Plunge
59		90 <sup>°1</sup>
79	S 72°W	90°
99	S 75° W	89°
119	S 72° W	89°
Average	S 72° W	89°

<sup>1</sup> ° = degrees.

**2. Water level data** — Note depths and/or elevations, water quantities, and pressures from artesian flows. Water levels or flows should be recorded during hole advancement, between shifts, or at the beginning or end of a shift, but definitely should be recorded at completion of the hole and periodically thereafter. It may be advantageous to leave space or provide a note to refer the user to additional readings provided elsewhere on the log for subsequent measurements. Computer generated logs allow convenient updating of water levels long after the hole is completed.

Examples of drill hole logs illustrate optional format and subsequent readings. Examples of how to record data are:

## CORE LOGGING

Date 1981	Hole depth (feet)	Depth to water (feet)
11-02	25.0	6.0
Bailed 100 gal:		
Level before		6.0
Level after		21.0

or:

Date	Hole depth (feet)	Depth to water (feet)
11-03-81	25.0	15.0
11-04-81	40.0	29.0
01-05-82	95.2	7.0
01-15-82	95.2	Flowing 25 gal/min
02-03-82	95.2	Flowing 5 gal/min at 5 pounds per square inch (lb/in <sup>2</sup> )

**3. Hole completion** — Indicate how hole was completed or backfilled; if jetting, washing, or bailing was employed; depth of casing left in hole or that casing was pulled; location and type of piezometers; location, sizes, and types of slotted pipes (including size and spacing of slots) or piezometer risers; type and depth of backfill or depths of concrete and/or bentonite plugs; location of isolated intervals; and elevation at top of riser(s). Hole completion can be shown graphically (see figure 10-5).

# FIELD MANUAL

IS-1764-A (4/75)

GEOLOGIC LOG OF DRILL HOLE											
FEATURE San Luis Dam-SEED		PROJECT Central Valley Project, California		STATE California		HOLE NO. DH-DN/P-60-1		GROUND ELEVATION 381.5'		ARTICLE FROM	
LOC. 2-17-82		COORDINATES FINISHED 2-23-82		TOTAL DEPTH 50.0'		VERTICAL Vertical					
BEGUN 2-17-82		FINISHED 2-23-82		HOLE LOGGED BY J. Darling		DRILLER H. Ferrell					
NOTES On water table levels, water return, character of drilling	Type and Size of Hole	Recovery	DENSITY (lb./ft. <sup>3</sup> )		Specific Gravity	DEPTH	FIELD VISUAL CLASSIFICATION AND PHYSICAL CONDITION				
			Wet	Dry							
<b>Purpose of Hole:</b> Under the Safety Examination of Existing Dams (SEED) program, to obtain undisturbed Pitman soil samples and to install piezometers.							0.0-22.0'; <b>SOME 3 EMBANKMENT</b>				
<b>Location of Hole:</b> Station 60+21.8; offset 542.3' left of dam centerline.							22.0-50.0'; <b>Rockbit - No Recovery</b>				
<b>Drill Bit:</b> Falling 1500							50.0-51.0'; <b>Sandy clay (CL).</b> Approx. 70% medium plastic fines; 30% fine to coarse sand; trace of lime, hard, subangular to angular gravel, max. size 20 mm. Soft to firm; moist; brown with bluffs of blue clay to 20 mm. Strong reaction with HCl.				
<b>Drilling Methods:</b> Drilled with 3 1/2" "Reverable mud".							51.0-66.5'; <b>Pitcher Sample.</b>				
0.0-5.0'; 6 1/2" rockbit							66.5-77.0'; <b>Sandy clay (ML).</b> Approx. 60% medium to low plastic fines; 40% fine to coarse sand; 10% fine and coarse, hard, subrounded gravel, max. size 40 mm. Soft; moist to dry; blue-green. Weak reaction with HCl.				
5.0-7.0'; Pitcher sampler.							77.0-100.0'; <b>Rockbit - No Recovery.</b>				
7.0-10.0'; 8 1/2" rockbit							100.0-101.0'; <b>Contaminated Sample - Sand/Clay (CL).</b> Similar to 6.67-7.0'; interval except: Firm.				
10.0-14.0'; Pitcher sampler.							101.0-112.0'; <b>Sandy clay (CL-CH).</b> Approx. 60% medium to highly plastic fines; 40% fine to coarse sand; 10% fine and coarse, hard, subrounded gravel, max. size 60 mm. Firm; moist to dry; blue-green. Weak reaction with HCl.				
14.0-15.0'; 8 1/2" rockbit.							112.0-123.0'; <b>Pitcher Sample.</b>				
15.0-50.0'; Pitcher sampler.							123.0-134.0'; <b>Sandy Clay (CL-CH).</b> Similar to 12.0-12.36' interval except: max. size 40 mm; traces of brown spots.				
33.0-35.0'; Clean 45.0' out with 8 1/2" rockbit.							134.0-15.0'; <b>Rockbit - No Recovery.</b>				
<b>Drilling Conditions:</b> 0.0-33.0'; Medium fast, smooth.							15.0-35.0'; <b>Clayey sand with gravel (SC).</b> Approx. 50% fine to coarse sand; 50% low plastic fines; 20% fine and coarse, subrounded to subangular gravel, max. size 60 mm. Soft; moist to wet; gray-black to green. Weak reaction with HCl.				
33.0-49.0'; Medium slow, smooth.							35.0-45.0'; <b>Pitcher Sample.</b>				
<b>Estimated Drilling Fluid Returns:</b> 0.0-25.0'; 85% 25.0-35.0'; 75% 35.0-45.0'; 80% 45.0-50.0'; 95-98%							45.0-50.0'; <b>Lean to Fat Clay (CL-CH).</b> Approx. 95% medium to highly plastic fines; 5% fine sand. Firm; dry to moist; blue-green. Weak reaction with HCl.				
<b>Casing Record:</b> Drilled Depth Type Interval Casing Case							50.0-50.0'; <b>Scattered claystone fragments and brown clay lumps.</b>				
0.0-14.0' 8.5" 10" 14.0-25.0' 8.5" 10" 25.0-50.0' 20.0" 10"							50.0-59.30'; <b>Lean to Fat Clay (CL-CH).</b> Approx. 80% medium to highly plastic fines; 20% fine to coarse sand; 10% fine, hard, subrounded gravel, max. size 15 mm. Firm; dry to moist; blue-green, with traces of brown spots. Weak reaction with HCl.				
<b>Hole Completion:</b> Flushed hole with fresh mud and Petro Breaker 4 & B. Installed two vibrating							59.30-20.73'; <b>Pitcher Sample.</b>				
							20.73-21.57'; <b>Clayey Sand with Gravel (SC)</b> Approx. 60% fine to coarse sand; 40% low plastic fines; 30% fine and coarse, hard, subrounded gravel, max. size 40 mm. Soft to firm; moist to wet; brown with blue-green mottling. No reaction with HCl.				

### EXPLANATION

Sheet 1 of 3

FEATURE: San Luis Dam-SEED      FEATURE: Central Valley Project, California      HOLE NO. DH-DN/P-60-1

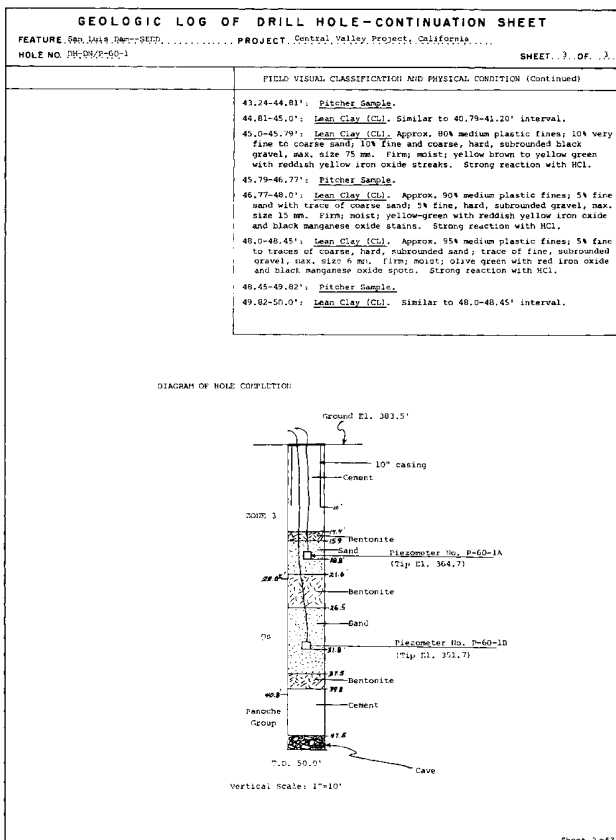


# CORE LOGGING

GEOLOGIC LOG OF DRILL HOLE—CONTINUATION SHEET																	
FEATURE: San Luis Dam—SEED	PROJECT: Central Valley Project, California	SHEET: 2 OF 3															
HOLE NO. DH-DN/P-60-1																	
NOTES (Continued)	FIELD VISUAL CLASSIFICATION AND PHYSICAL CONDITION (Continued)																
<p>Hole Completion (Continued): wire piezometers; tips at 38.8' (E1, 304.7) and 31.8' (E1, 351.7). Backfilled hole to surface as shown on diagram, sheet 3. Left 20' of 10" casing in hole.</p> <p>Drilling Mud Level</p> <table style="width: 100%; border-collapse: collapse;"> <thead> <tr> <th style="width: 10%;">Date</th> <th style="width: 10%;">Depth Mud</th> <th style="width: 10%;">Depth Hole</th> </tr> </thead> <tbody> <tr> <td>2-17-62</td> <td>7.0'</td> <td>25.0'</td> </tr> <tr> <td>2-18</td> <td>2.0'</td> <td>25.0'</td> </tr> <tr> <td>2-22</td> <td>7.5'</td> <td>45.0'</td> </tr> <tr> <td>2-23</td> <td>6.4'</td> <td>45.0'</td> </tr> </tbody> </table>	Date	Depth Mud	Depth Hole	2-17-62	7.0'	25.0'	2-18	2.0'	25.0'	2-22	7.5'	45.0'	2-23	6.4'	45.0'	<p>21.57-22.01': Pitcher Sample.</p> <p>NOTE: The top of the Quaternary Slopewash is assumed to lie within the sample taken from the 21.57-22.81' interval.</p> <p style="text-align: center;">*22.0- 240.79': <u>QUATERNARY SLOPEWASH AND RESIDUAL SOIL.</u></p> <p>22.81- 233.4': <u>Fat Clay (CH)</u>. Approx. 90% highly plastic fines; 10% fine to coarse, hard, subrounded sand. Firm; moist; brown, light brown, dark brown with scattered white grains of calcium carbonate. No reaction with HCl except for violent reaction on carbonate grains.</p> <p>At 23.0': One hard, subrounded, 90 mm dia. cobble.</p> <p>23.4- 224.7': <u>Pitcher Sample</u>. (Contaminated by Drilling Mud.)</p> <p>24.7-25.0': <u>Fat Clay (CH)</u>. Approx. 95% highly plastic fines; 5% fine to coarse sand; 5% fine and coarse, hard, subrounded gravel, max. size 30 mm. Firm; moist; dark brown. No reaction with HCl.</p> <p>25.0- 226.3': <u>Fat Clay with Gravel (CH)</u>. Approx. 80% highly plastic fines; 15% fine and coarse, hard, rounded gravel, max. size 50 mm; 5% fine to coarse sand. Firm; moist; dark brown. No reaction with HCl.</p> <p>226.3- 226.7': <u>Pitcher Sample</u>.</p> <p>226.7-27.0': <u>Fat Clay with Gravel (CH)</u>. Similar to 25.0- 226.3' interval except: Red-brown to brown; one 80 mm rounded cobble.</p> <p>27.0-27.58': <u>Fat Clay (CH)</u>. Approx. 95% highly plastic fines; 5% fine to trace of coarse, hard, subrounded sand, max. size 4 mm. Firm; moist; red-brown. Weak reaction with HCl.</p> <p>27.58-28.81': <u>Pitcher Sample</u>.</p> <p>28.81-29.43': <u>Fat Clay (CH)</u>. Similar to 27.0-27.58' interval.</p> <p>29.0-29.43': No reaction with HCl.</p> <p>29.43-30.81': <u>Pitcher Sample</u>.</p> <p>30.81-31.81': <u>Sandy Clay (CL)</u>. Approx. 75% low to medium plastic fines; 25% fine to medium sand. Soft; moist; yellow-brown with red-brown streaks. No reaction with HCl.</p> <p>31.0-31.81': Very soft; moist to wet. Possibly cave.</p> <p>31.81-32.82': <u>Pitcher Sample</u>.</p> <p>32.82-33.0': <u>Sandy Clay (CL)</u>. Similar to 30.81-31.81' interval.</p> <p>33.0-35.0': <u>No Recovery - Sample lost in hole</u>.</p> <p>35.0-35.36': <u>Sandy Clay (CL)</u>. Similar to 30.81-31.81' interval except: Trace of coarse, hard, subrounded sand, max. size 4 mm. Weak reaction with HCl.</p> <p>35.36-36.78': <u>Pitcher Sample</u>.</p> <p>36.78-37.0': <u>Sandy Clay (CL)</u>. Similar to 30.81-31.81' interval except: trace of coarse, hard, subrounded sand; trace of fine, subrounded gravel, max. size 10 mm.</p> <p>37.0-37.17': <u>Sandy Clay (CL)</u>. Approx. 75% medium plastic fines; 25% fine to traces of coarse, hard, subrounded sand, max. size 4 mm. Firm; moist; brown. Weak reaction with HCl.</p> <p>37.17-38.80': <u>Pitcher Sample</u>.</p> <p>38.80-39.0': <u>Sandy Clay (CL)</u>. Similar to 37.0-37.17' interval.</p> <p>39.0-39.22': <u>Lean Clay (CL)</u>. Approx. 90% low plastic fines; 10% fine to traces of coarse sand, max. size 4 mm; trace of soft, light brown claystone fragments to 20 mm max. size, easily broken with fingers. Firm; moist to wet; brown with dark brown streaks. No reaction with HCl.</p> <p>39.22-40.75': <u>Pitcher Sample</u>.</p> <p style="text-align: center;">*40.79-50.0': <u>PANOCHE FORMATION</u> (Cretaceous)</p> <p>40.79-41.20': <u>Lean Clay (CL)</u>. Similar to 39.0-39.22' interval except: Very firm; trace to 10% claystone fragments; many calcium carbonate streaks. Strong reaction with HCl. Light brown to light yellow brown.</p> <p>41.20-42.81': <u>Pitcher Sample</u>.</p> <p>42.81-43.24': <u>Lean Clay (CL)</u>. Similar to 40.79-41.20' interval.</p>	
Date	Depth Mud	Depth Hole															
2-17-62	7.0'	25.0'															
2-18	2.0'	25.0'															
2-22	7.5'	45.0'															
2-23	6.4'	45.0'															
FEATURE: San Luis Dam—SEED	PROJECT: Central Valley Project, California	SHEET 2 OF 3 HOLE NO. DH-DN/P-60-1															

**Figure 10-5.—Drill hole log, DH-DN/P-60-1, sheet 2 of 3.**

# FIELD MANUAL



Sheet 3 of 3  
HOLE NO. DH-DN/P-60-1  
60-1

**Figure 10-5.—Drill hole log, DH-DN/P-60-1, sheet 3 of 3.**

## CORE LOGGING

**4. Reason for hole termination** — State whether the hole reached the planned depth or reason why the hole was stopped short.

**5. Drilling time** — Total time, setup time, drilling time, and downtime should be recorded on drillers' daily sheets and should also be recorded on the drill log. These records are essential for determining exploration program costs.

### Center Columns of the Drill Log

**Computer Logs.**—Computer-generated logs offer several options for the content and format of the log such as permeability, penetration resistance, or rock properties which have some differences in format. Examples of each are shown in figures 10-2 through 10-5.

**Standard Geologic Log Form.**—The following discussion pertains to the center columns for the standard Reclamation log (form 7-1337). The columns shown on all figures are self-explanatory. The columns can be modified or new columns added to the existing log form for recording appropriate indexes or special conditions.

The percolation tests (water-pressure tests) column should record the general information of the tests. Additional data may be recorded on "water testing" log forms or drillers' reports.

Type and size of hole, elevation, and depth columns are self-explanatory.

Core recovery should be recorded in percent of recovery by run. Although desirable, core recovery does not necessarily require a visual graph. Core recovery should be noted carefully by the driller for each run on the daily

## FIELD MANUAL

drill reports; however, this column should be the record of those measurements determined by the geologist during logging. Measuring the core while in the split tube or sampler, if possible, will produce the most accurate recovery records.

A hole completion column may be added which graphically portrays how the hole was completed. If used, an explanation of the graphic symbols should be provided on the log form.

Rock quality designation (RQD) should be reported by core run. RQD should be included on the log in graph or tabular form regardless of the type project. RQD is used in almost any engineering application of the hole data. Most contractors are interested in RQD as an index of blasting performance, rippability, and stability. RQD is described and explained in chapter 5.

A lithologic log or graphic column is helpful to quickly visualize the geologic conditions. Appropriate symbols may be used for correlation of units, shear zones, water levels, weathering, and fracturing (see figure 10-1).

The samples and testing column should include locations of samples obtained for testing and can later have actual sample results inserted in the column, if the column is enlarged.

**Modifications to Standard Log Form.**—Modifications or adaptations of the center columns are permissible and, in some instances, encouraged. Examples are:

1. The use of a continuation sheet for longer drill logs saves time and is easier to type. The sheets may have only one column to continue the right-hand narrative, or may be divided into two or more

## CORE LOGGING

columns. See sheets 2 and 3 for drill hole SPT-107-2, figure 10-4, for an example; also see sheet 3 of 3 for drill hole DH-DN/P-60-1, figure 10-5.

2. The center column may be modified to portray additional data such as hole completion, various indexes, alphanumeric descriptors, or laboratory test data.

Standard penetration test hole SPT-107-2, figure 10-4, is a modified penetration resistance log which shows laboratory test results; a percent gravel/percent sand/ percent fines column; liquid limit/plasticity index (LL/PI) column, a field moisture column, and other modifications. Drill hole DH-SP-2, figure 10-3, has columns for reporting field density test results, moisture, porosity, percent saturation, percent fines/percent sand, LL/PI, and laboratory classification.

3. Another modification, shown on DH-SP-2, figure 10-3, is a drawing showing the location of the hole in relation to the structure being explored. Diagrams or graphs, such as water levels, may illustrate data better than a column of figures.

### **Required Data and Descriptions for the Right-Hand "Classification and Physical Condition" Column**

**General.**—An accurate description of recovered core and a technically sound interpretation of nonrecovered core are the primary reasons for core logging. The logger needs to remember that any interpretation, such as a shear, must be based on observed factual data. The interpreted reason for the core loss is given, but usually

## FIELD MANUAL

it is best to define the area of core loss as the interval heading. For example:

99.4. to 101.6: No Recovery. Interpreted to be intensely fractured zone. Drillers reported blocking off, core probably ground up during drilling.

103.4 to 103.7: Open Joint?. Drillers reported 0.3-ft drop of drill rods during drilling and loss of all water. Joint surfaces in core do not match.

0.7 to 11.6: Silty Sand. Poor recovery, only 6.2 ft recovered from interval. Classification based on recovered material and wash samples.

0.9 to 3.2: Rockbitted. No samples recovered. (Usually this would be subheaded under a previous description, inferring the materials are the same as the last recovered).

**Descriptions of Surficial Deposits.**—Surficial deposits such as slope wash, alluvium, colluvium, and residual soil that are recovered from drill holes are described using USBR 5000 and 5005. If samples cannot be obtained, then description of the cuttings, percent return and color of drilling fluid, drilling characteristics, and correlation to surface exposures is employed. Always indicate what is being described—undisturbed samples, SPT or wash samples, cuttings, or cores. Descriptors and descriptive criteria for the physical characteristics of soils must conform to the established standards. Chapter 11 provides guidelines for soil and surficial deposit descriptions.

Extensive surficial deposits usually are described using geologic and soil classifications. Where surficial deposits are very shallow and not pertinent to engineering applications for design or remediation or where geologic

## CORE LOGGING

classification such as landslides or talus is preferable, units may be given genetic or stratigraphic terms only. For example, Quaternary basin fill, recent stream channel deposit, Quaternary colluvium, zone 3 embankment, and random fill may be described generally; or these may be unit headings with group name subheadings. The format is:

**Geologic and group name.** i.e., Alluvium, (sandy silt). Field classification in parentheses if classified, refer to chapters 3 and 11 for exceptions.

**Classification descriptions.** Additional descriptors (particle sizes, strength, consistency, compactness, etc., from the USBR 5000 and 5005 standards descriptive criteria).

**Moisture.** (dry to wet).

**Color.**

If cores or disturbed samples are not available, describe as many of the above items as can be determined from cuttings, drill water color, drilling characteristics, correlation to surface exposures, etc. Remember that for rockbitted, no recovery, or poor recovery intervals, a classification and group name should be assigned as a primary identification.

**Description of Rock.**—Description of rock includes a rock unit name based on general lithologic characteristics followed by data on structural features and physical conditions. Bedrock or lithologic units are to be delineated and identified, not only by general rock types but by any special geological, mineralogical features with engineering significance, or those pertinent to interpretation of the subsurface conditions.

## FIELD MANUAL

Any information which is characteristic of all of the rock units encountered normally is included under the main heading, producing more concise logs. Differences can be described in various subheadings. Rock core is to be described in accordance with descriptors and descriptive criteria presented in chapters 4 and 5. A suggested format is:

**1. Rock name** — A simple descriptive name, sufficient to provide others with possible engineering properties of the rock type; may include geological age and/or stratigraphic unit name.

**2. Lithology (composition/grain sizes/texture/color)** — Give a brief mineralogical description. Describe grain shape and size or sizes and texture using textural adjectives such as vesicular, porphyritic, schistose. (Do not use petrographic terms such as hypidiomorphic, subidioblastic). Other pertinent descriptions could include porosity, absorption, physical characteristics that assist in correlation studies, and other typical and/or unusual properties. Provide the wet color of fresh and weathered surfaces.

Contacts should be described here also. If the contacts are fractured, sheared, open, or have other significant properties, the contacts should be identified and described under separate subheadings.

**3. Bedding/foliation/flow texture** — Provide a description of thickness of bedding, banding, or foliation including the dip or inclination of these features.

**4. Weathering/alteration** — Use established descriptors which apply to most of the core or use individual subheadings. For alteration other than



## CORE LOGGING

weathering, use appropriate descriptors. These may or may not be separate from weathering depending upon rock type and type of alteration. Also, include slaking properties if the material air or water slakes. (Weathering may be used as first or second order headings for some logs.)

**5. *Hardness*** — Use established descriptors.

**6. *Discontinuities*** — These include shears, joints, fractures, and contacts. Discontinuities control or significantly influence the behavior of rock masses and must be described in detail. Detailed discussions of indexes and of descriptive criteria, descriptors, and terminology for describing fractures and shears are provided in chapter 5 and 7.

Fractures or joints should be categorized into sets if possible, based on similar orientations, and each set should be described. When possible, each set should be assigned letter and/or number designations and variations in their physical properties noted by depth intervals. Significant individual joints also may be identified and described. Physical measurements such as spacing and orientation (dip or inclination from core axis), information such as composition, thickness, and hardness of fillings or coatings; character of surfaces (smooth or rough); and, when possible, fracture openness should be recorded. In drill core, the average length between fractures is measured along the centerline of the core for reporting any of the fracture indexes. However, when a set can be distinguished (parallel or subparallel joints), true spacing is measured normal to the fracture surfaces.

## FIELD MANUAL

**Description of Shears and Shear Zones.**—Shears and shear zones should be described in detail, including data such as the percentage of the various components (gouge, rock fragments, and associated features such as dikes and veins) and the relationship of these components to each other. Gouge color, moisture, consistency and composition, and fragment or breccia sizes, shape, surface features, lithology, and strengths are recorded. The depths, dip or inclination, and true thickness, measured normal to the shear or fault contacts, also must be determined, if possible, along with healing, strength, and other associated features. A thorough discussion of shears and shear zones is contained in chapter 5.

**Description of Core Loss.**—The significance of core loss is often more important than recovered core. Lost core may represent the worst conditions for design concepts, or it may be insignificant, resulting from improper drilling techniques or equipment. Core losses, their intervals, and the interpreted reason for the loss should be recorded on the log.

**Written Description Form.**—The written description for physical conditions consists of main headings, indented subheadings, and text which describes the important features of the core. Headings and indented subheadings divide the core into readily distinguishable intervals which are pertinent to an engineering geology study. Assigned unit names should correlate with those unit names used for surface mapping. These headings may describe portions of the core or the entire core, depending on how well the headings encompass overall characteristics. Items characteristic of the entire core in one hole may be stated under the major heading; however, in other holes, this same information may have to be broken out into various subheadings because it is not applicable to the entire core. In this discussion,

## CORE LOGGING

several logs are referenced as examples. These logs do not necessarily reflect the established standards, and each may be deficient in some format or context; they are existing logs which are included as examples of different situations which may be encountered. A discussion of headings follows:

**1. Main headings** — The main heading usually divides surficial deposits from bedrock. However, other methods are also acceptable, for example, the summary log in figure 10-5.

**2. First order heading** — The first order headings may be based on weathering or lithology. When the initial rock type exhibits more than one weathering break or the lithologic properties are most significant, lithology would be the first order heading. Weathering may be used as first order headings where significant. If a weathering break coincides with a lithologic break, or only one weathering break is present, they may both be included in the main heading. Depending on lithologies present, for example, if there is only one rock type, the first order headings may be based on fracturing. Lithology, weathering, or fracturing can also be the subject of the first order heading. In certain circumstances, a shear or shear zone or other feature could be given a first order or any lower order heading in order to emphasize a feature's presence or importance. The arrangement which will result in the simplest log is usually the best and should be used. The following examples illustrate the use of first, second, and third order headings. These examples are not intended to represent examples of complete logs.

An example in which weathering is preferred as the first order heading is:

## FIELD MANUAL

0.0-5.0: SLOPE WASH (main heading).—General description could include the total description of the unit.

5.0-200.0: PALEOZOIC CALAVERAS GROUP (main heading).

5.0-100.3: Moderately Weathered (first order heading based on weathering; descriptions of weathering applicable to all lithologies could be presented here).

5.0-10.9:	Basalt
10.9-20.1:	Limestone
20.1-50.3:	Shale
50.3-100.3:	Sandstone

100.3-150.0:	<u>Slightly Weathered</u>
100.3-120.2:	Sandstone
120.2-150.0:	Shale

150.0-200.6:	<u>Fresh Shale</u>
--------------	--------------------

An example in which lithology is preferred as the first-order subheading is:

0.0-5.0: SLOPE WASH (main heading).—General description, could include the total description of the unit.

5.0-200.6: PALEOZOIC CALAVERAS GROUP (main heading).—General description applicable to all lithologies.

5.0-100.3: Sandstone (first order heading based on lithology)

5.0-10.2: Intensely weathered

## CORE LOGGING

10.2-40.1: Moderately weathered

40.1-80.2: Slightly weathered

80.2-100.3: Fresh

100.3-150.1: Fresh Shale (first order heading which combines weathering and lithology)

150.1-200.6: Fresh Diabase

**3. Second order heading** — The second order heading and the associated description contain the characteristics of the rock that are unique to an interval that is not described in the main and first order headings. The second order heading usually is based on weathering if the first order heading is based on lithology. If the first order heading is based on weathering, the second order heading would usually be based on lithology. Fracture data can be described here if similar throughout the interval; if not, divide fracture data into third order headings.

**4. Third order heading** — The third order heading is usually based on fracture data, subordinate features, variations in lithology, etc. This includes variations of rock quality within a certain lithology due to shears, joints, bedding or foliation joints, or other discontinuities. Core recovery lengths are an indicator of fracturing and should be described under this heading, as in the interval from 87.2 to 101.2 in DH-123 figure 10-1. If the fractures are mainly prominent joint sets or other discontinuities, the spacing and orientation of individual sets, along with the overall fracture characteristics, should be noted.

## FIELD MANUAL

**5. Additional indentations** — Additional indentations usually are used to describe important additional subordinate features, such as veins or veinlets, variations in lithology, shears, and zones of non- or poor recovery.

In summary, any information consistent throughout a higher order heading, but usually included in a lower one, should be described in the higher order heading to prevent repetition.

### **Data Required for the Comments/Explanation Block**

The comments/explanation block at the bottom of the log form is used for additional information. This may include abbreviations used, gauge height for packer tests, and notes. The hole start and completion date should be in the heading, as well as the date logged. Revision dates of the log should be noted to ensure that the most recent version of the log can be identified. (Date logged and any subsequent revision dates should be entered in this block). The computer log file name can be recorded in this block.

### **Method of Reporting Orientation of Planar Discontinuities and Structural Features**

True dips can be measured directly in vertical holes. The dips of planar features in vertical holes are recorded as "dips 60°" or "60° dip" (see drawing 40-D-6499, figure 5-9). True dip usually is not known in angle holes; and, orientation is measured from the core axis and called inclination, i.e., "Joints are inclined 45° from the core axis" (figure 5-9). If dips are known from oriented core or other surveys, dips may be recorded instead of inclination

## CORE LOGGING

in angle holes. Figure 5-9 demonstrates how misinterpretations can occur; the inclination of a joint in the core from a  $45^\circ$  inclined angle hole can be interpreted as a horizontal joint or as a vertical joint by rotating the core.

### **Core Recovery and Core Losses**

Descriptions of core in the Classification and Physical Condition column should describe the recovered core, not only by physical measurements (maximum, minimum, and mostly range or average), but should identify and include the interpretation for any core losses, especially if the losses are thought to represent conditions different from the core recovered. Designers and other users of the completed log can incorporate into their design all the factual data that are seen and recorded. What is not seen or reported (core losses) is more difficult to incorporate into the design and may well be the most significant information. Also, core losses and interpretations of the reasons for their loss are significant engineering data that may correlate open joints, soft zones, or shears from boring to boring or from surface features to the subsurface explorations.

Core losses can result from three generalized conditions: inaccurate measurements by the drillers; poor drilling techniques, equipment, and handling; or geologic conditions. The geologist, using the depth of hole, recovered core, observations of the core, and drillers observations, is the individual to make interpretations of the core loss. All core should be measured by the logger. If using a split-tube barrel, the core should be measured while in the barrel and always after core segments are fitted together (using the midpoint of core ends). Unaccountable losses should be reconciled, and the location of the loss determined.

## FIELD MANUAL

Tape checks or rod checks are the most reliable and preferred methods for knowing the exact location of geologic conditions (top of each run is known with certainty) and where losses occur. All core runs should be measured and recorded; gains and losses can be transferred to adjacent runs and cancel out each other during the process of determining where the core loss is located. Inaccurate drillers' measurements, or locations where portions of the previously drilled interval was left in the hole (pulled off, or fell back in and redrilled), can be determined by examining and matching the end and beginning of each core run to see if they fit together or show signs of being redrilled. Gains may be attributed to pulling out the bottom of the hole, mismeasurement, recovering core left in the hole from the previous run, or recovery of expansive, slaking, or stress relieving materials.

Where unaccountable losses occur, the examination of core to determine the reason for that loss is critical. Poor drilling methods (excessive pressure, speed, excessive water discharge from the drill bit, not stopping when fluid return plugs), inaccurate measurements, or geologic conditions responsible for core losses should be determined. Core may have spun in the barrel after blocking; an intensely fractured zone may have been ground up; or a shear zone, open joint(s), solution cavity, or joint fillings may have been washed away. Geologic interpretation of the core loss is based on examining recovered core and the fractures present in the core. Drill water losses and color or changes in the drilling conditions noted by the driller may suggest an interpretation of the core loss. Where losses occur near a recovered clay "seam," clay coats fracture surfaces, slickensides and/or breccia and gouge are present, the core loss may be interpreted as a shear or shear zone. The description should include all the factual information—discontinuity surface orientations, slickensides, coatings, gouge and/or fractures; and the



## CORE LOGGING

interpretation that the loss occurred in a shear. Depending on the confidence in the interpretation based on the observed conditions, the description can be given as "shear," or "shear?," or "probable shear zone." When a portion of a shear zone has been lost during drilling, the no recovery zone should be described as part of the shear and the loss or part of the loss included in the shear's thickness.

### **Samples**

If the geologist selects representative or special samples for laboratory testing, an appropriate space should be left in the core box to ensure that when logs are reviewed or photographs are taken, core recovery is not misleading. Either filler blocks or a spacer which indicates the top and bottom depths of the sample and a sample number can be used to fill the sample space. For N-size cores, a length of 2- by 2-inch (50- by 50-mm) block or other spacers that fill the tray work well. These blocks also should be used to separate core runs. The lettering on the blocks should be easily readable at a distance. Spray painting the blocks white or yellow and lettering them with black waterproof pens enhances visibility and legibility. The sample interval, and sample number if desired, must be recorded in the Samples for Testing column on the log. Portions of the core may be preserved as representative samples or to protect samples from slaking or other deterioration.

## FIELD MANUAL

### Core Photography

#### General Photographic Methods

Transmittal of core photographs with the final logs is recommended. The photos may be included in the data package or as an appendix to the data report. Cores should be photographed while fresh. Before and after photographs of materials that slake or stress-relieve are recommended. The importance of photographing the core before it has been disturbed in transit and before its moisture content has changed cannot be overemphasized. If proper precautions during transport are followed, and the core is logged in a timely manner, reasonably good photographs can be obtained away from the drilling site. This permits the labeling of core features, if desired.

If possible, cores should be photographed in both color and black and white at 8- by 10-inch (200- by 250-mm) size. Black and white photographs do not degrade over time like color photographs. Core photographs should be submitted with the final logs in the geology data report; color photographs are best for data analysis.

Many methods are employed for photographing core. Each box of core can be photographed separately as the box is first filled or three or more boxes can be photographed at a time. There are advantages to both procedures:

- Greater detail and photographs depicting fresher conditions are the major advantages of photographing each box individually.
- When photographing several boxes at a time, transitional features, changes in weathering or fracturing, or large shear zones can be seen in one photograph.

## CORE LOGGING

The best method is a combination of the two. Pictures of individual boxes at the drill site and later pictures of the entire hole are the best of two worlds.

### **Individual Box Photography**

Any portion of core that is in danger of altering or disaggregating because of slaking or "discing" due to stress relief, expansion, or shrinkage due to changes in moisture or confinement because of down time, ends of shifts, or weekends must be boxed and photographed. Under these circumstances, the core should be photographed while at or near the material natural condition (even if a box is only partially filled).

Each photograph should be taken from approximately the same distance so that the scale of each photograph is identical. The box should fill the frame of the camera, thereby obtaining the highest quality resolution or core detail, and the camera should be held as close to normal to the core as possible. A tripod should be used if possible. Tilting the core box and, if necessary, standing in a pickup bed or other vantage point may be helpful. Most core boxes can be tilted about 70 to 80° before any core is in danger of spilling out, so very little additional height is required. A simple 2- by 4-foot (0.6- by 1.2-m) wood frame may be constructed, or the core box may be leaned against a tool box, pickup tailgate, or other stable object. A Brunton compass can be used to ensure that the box and the camera are placed at a consistent, uniform angle. Shadows should be eliminated as much as possible.

All core should be photographed both wet and dry. In hot or dry weather, the unphotographed boxed core should be covered by moist cloth. When ready to photograph, any dry zones should be touched up using a wet cloth or

## FIELD MANUAL

paintbrush. In extremely hot weather, the boxed core can be sprayed or sprinkled with water. A water hose, garden sprayer, or spray bottle works well for this operation. Wait for the water to be absorbed so that there is no objectionable sheen or glare-producing film of water on the core at the instant of film exposure.

A labeled lid, letter board, or another frame which shows feature, drill hole number, photograph, or core box number, and depths of the top and bottom of the cored interval should be included in the photograph. A scale in feet and/or tenths of a foot or meters is helpful.

### **Photographing Multiple Boxes**

As soon as possible after the core is removed from the barrel and boxed, the core should be photographed. To facilitate the photography, construct a frame capable of supporting three or more boxes at a time for use at the drill yard or core storage yard. Photograph the core dry then spray with water to bring back the natural moisture color. The same precautions about glare referred to previously should be followed.

A frame which shows the project, feature, hole number, box \_\_ of \_\_ boxes, and from—to, as a minimum, should be used for the photograph. Other optional but recommended entries may include date photographed, and a scale.

### **Special Circumstances**

Special photography such as closeups of shear zones or other special features may be worthwhile. When these photographs are taken, a common object or scale should be included to provide the viewer with relative or actual dimensions.

## CORE LOGGING

When cores are coated with drill mud, a brush, wet rag, or pocket knife should be used to wash or scrape off the mud so that materials are their natural color and features of the core are not obscured. This step obviously must be taken prior to logging the material.

### **Photograph Overlays**

Acetate or mylar overlays on photographs of core can help interpretation of exposed features. Details shown may include labels for shears, weathering, lithologies, or items of special interest. Other items that may be shown on overlays are joint sets, and they may be coded by an alpha or numeric character or by colored ink.

### **Equipment Necessary for Preparing Field Logs**

The following equipment or supplies are necessary for adequately preparing geologic logs:

Core recovery sheets and rough log forms or computer data sheets.—For recording core recovery and maintaining accurate depth measurements for determining core loss intervals.

Drillers' reports.—Daily drill reports (figure 10-6) to check measurements for core recovery, identifying changes in condition or contacts in intervals of poor recovery, determining reasons for core loss, and evaluating openness of fractures.

Knife.—Core hardness/strength characteristics; cleaning or scraping drill mud from core to allow logging and measurement of core recovery.

Hammer.—Core hardness/strength characteristics.

**DAILY DRILL REPORT**

Drill hole number \_\_\_\_\_

Feature \_\_\_\_\_

Date \_\_\_\_\_

Project \_\_\_\_\_

State \_\_\_\_\_

Depth to water begin of shift \_\_\_\_\_, measuring point (describe) \_\_\_\_\_ at \_\_\_\_\_ ft. (height) above ground.

INTERVAL		OVERBURDEN OR ROCK TYPE	DRILL METHOD			DRILL CASING			PR TEST (18" total)	DRILLING MEDIUM					
From	To		Bit or Sampler Size	Type 1/	Length of Borel or Sampler	Size	Depth	Blows			Air (Cfm)	Water (Describe Quality)	Additives 2/ (Describe)	Color of fluid returns	Percent of returns
								6"	6"	6"					

**COMMENTS**

From	To

**EQUIPMENT NO. HRS. GAS**

Depth to water	Drill	Pump	Compressor	Welder	Other	EQUIPMENT NO.	HRS.	GAS

Notes: Following are examples of descriptive words and symbols to be used.  
 1/ Type bit or sampler: D = diamond, TC = Tricone, DN = Danison, WB = Wash Boring, etc.  
 2/ Additives: Bentonite, Revert, Loaloss, Salt Brine, Clay, V7E, etc.

Driller \_\_\_\_\_  
 Helper \_\_\_\_\_  
 Helper \_\_\_\_\_  
 Rig Used \_\_\_\_\_  
 Hole Number \_\_\_\_\_

Figure 10-6.—Daily drill report.

## CORE LOGGING

Tape measure or folding ruler (engineering scale with hundredths of feet or metric as appropriate).—Recovery measurements, thickness of units, shears and fillings, and spacing of fractures.

Protractor.—Measuring orientation of contacts, bedding and foliation, and fracture orientation.

Hydrochloric acid.—Mineral or cementing agent identification (3:1 distilled water to acid).

Hand lens.—Mineral or rock identification, minimum 10X.

Marking pen.—Waterproof ink for marking core for mechanical breaks, depth marks on core, sample marking.

Paintbrush and/or scrub brush, and water.—For cleaning core and for identifying wet color and incipient fractures.

Color identification charts (Munsel Color System or American Geological Institute Rock Color Chart).

Filler block (spacer) material.—For identifying non-recovery intervals and location of samples and for recording drill depths.

Sample preparation materials.—Wax, heater, container, brush, cheese cloth, etc.

Rock testing equipment.—Schmidt hammer, point load apparatus, pocket penetrometer or torvane.

## FIELD MANUAL

### **Instruction to Drillers, Daily Drill Reports, and General Drilling Procedures**

Communication between the geologist and driller is extremely important. Establishment of lines of communication, both orally and in writing, is key to a successful exploration program.

The role of the geologist in the drilling program is as an equal partner with the driller at the drill site. Establishment of this partnership at the beginning of the drilling program will result in better data. Failure to establish a good working relationship with the drill crew often results in unanswered questions and a poor quality end product. One way to establish good working rapport is to keep the drillers informed and to plan with them.

#### **Drill Hole Plan**

A suggested method for ensuring that a clear understanding of what the drilling requirements and expectations are from the drill hole is the preparation of a drill hole plan. The plan is prepared prior to starting the hole and after the geologist has used available interpretive data and has determined whether special testing and procedures or deviations in standard practice are required. This document provides the driller with information about safety, special site conditions, purpose of the hole, procedures to be followed, water testing requirements, materials expected to be recovered, any special sampling or geophysical testing required, and hole completion requirements.

#### **Guidelines for Drillers**

The following guidelines provide a framework for preparing written instructions for drill crews or for



## CORE LOGGING

contract drill specifications. Also, the guidelines serve to help geologists correct poor drilling procedures, collect additional data, or improve core handling and logging.

**Drill Setup.**—To ensure that drill holes are completed at the desired location and along the correct bearing and plunge, the use of aiming stakes and a suitable device for measuring angles should be provided by the geologist and used by the drill crews. Drillers should use aiming stakes set by the geologist or survey crew for the specified bearing of the drill hole. The rig must be anchored properly so that it will not shift. If stakes have been removed or knocked over, they should be replaced by the geologist. Also, drillers must ensure the hole is drilled at the designated angle. The geologist should check the plunge angle with Brunton compass, and/or the drillers should use an appropriate measuring device.

**Daily Drill Reports Preparation.**—The drillers should prepare duplicate daily drill reports using carbon paper (additional copies of each report may be required on contract rigs). All copies must be legible and preferably printed. One copy should be provided to the geologist for monitoring progress and for preparation of the geologic log. The drill report has a space opposite each run for each item of information required; each of these spaces need to be filled out completely. Data should be added to the report or recorded in a notebook after each run. Drillers should record data as it occurs. See drawing 40-D-6484 (figure 10-6) as an example for reporting daily drill activities. Many field offices have local forms on which these data can be recorded. Comments regarding specific items to be recorded on the daily reports are contained in the following paragraphs.

**1. Recording depths and core loss** — Check for agreement on depths for intervals drilled by

## FIELD MANUAL

consecutive shifts. Depths should be recorded in feet and tenths of feet or to the nearest centimeter, as appropriate. Tape checks or rod checks may be required at change of shift or more frequently when requested by the geologist. The section entitled "Core Recovery and Core Losses" contains instructions for proper use of core measurements, filler blocks (spacers), and tape checks. The driller is responsible for knowing the depth of the barrel and the hole at all times. Discrepancies between intervals drilled and recovery need to be resolved. Only standard length drill rods should be used. Core should be measured while it is still in the inner barrel and after it is placed in the core box. Record the most correct measurement of the two in the report. In the event core is left in the hole, the next run should be shortened accordingly; the left amount and proper hole entry and startup procedures should be followed to facilitate recovery.

**2. Recording drilling conditions** — Make sure drilling conditions, such as fast or slow, hard or soft, rough or smooth, even or erratic, moderately fast or very slow, bit blocks off, etc., are indicated for each run. Record time in minutes per foot (meter) of penetration. Any changes in the drilling rate within a run also should be noted along with intervals of caving or raveling. If the bit becomes plugged or blocking off is suspected, the driller should stop drilling and pull the core barrel. Also, when drill circulation is lost, the driller should pull and examine the core.

**3. Drilling fluid return and color** — The type, color, and estimated percent of drilling fluids returned should be recorded for each core run. The depth of changes in fluid loss or color is particularly

## CORE LOGGING

important. If drilling mud is used, indicate number of sacks used per shift. In case of total loss of drilling fluid, it may be necessary to pressure test the interval.

**4. Description of core** — Drillers need to describe the core in general terms; i.e., moderately hard, very hard, soft, clay seams, broken, color, etc. If familiar with the rock types, drillers may report more than just general terminology.

**5. Water-pressure testing** — Holes in rock are typically water tested in 10-foot (3-m) intervals at pressures of approximately  $\frac{1}{2}$  lb/in<sup>2</sup> (3.5 kilopascals [kPa]) to 1 lb/in<sup>2</sup> (6.90 kPa) per foot (1/3 m) of cover up to 100 lb/in<sup>2</sup> (690 kPa). NOTE: Pressures may be modified for each site. Factors such as density of materials, "overburden pressure" or "cover," bedding, purpose of testing, distances from free faces, water levels, and artesian pressures all must be taken into account so that pressure testing does not unintentionally hydrofracture the foundation or jack foundation materials. Pressures should be determined by the geologist. If a range of pressures is used, and disproportionately high water losses are obtained at the higher pressures, the pressures should be stepped down and water losses at the lower pressures recorded. Water test pressures should be stepped up 3 to 5 times and then stepped down. Flow versus pressure should be plotted; and if the relationship is not linear or smoothly curved, hydrofracturing or jacking may be occurring. If the decreasing pressure curve does not follow the increasing pressure curve, washing, plugging, or hydrofracturing or jacking may be occurring without the foundation materials returning to the prewater test state. Intentionally increasing the pressure until the foundation is fractured or jacked is a good

## FIELD MANUAL

way to determine appropriate grout pressures. Gravity tests, overlapping pressure tests, and variations in the length of the interval tested may be used to ensure complete test data. For example, a packer interval of 8 feet (2.4 m) may be used if the hole is caving too badly to get 10 feet (3 m) of open hole. Also, if a packer will not seat at 10 feet (3 m) above the bottom of the hole and there is good rock at 12 feet (3.66 m), a 12-foot test interval may be used. If losses are above 15 gal/min (1.146 liters per second [L/sec]), exceed pump or system capacity, or water is known to be bypassing the packer, reduce the length of the packer interval and retest.

Losses should be recorded in gallons and tenths of gal/min (L/sec). The driller should record the water meter reading at 1-minute intervals, and the test should be run for a full 5 minutes at each pressure increment after the flow has stabilized. The driller should report the average flow in gal/min (L/sec) for the 5-minute test. Each driller should keep his own record of the packer data in case questions arise concerning the testing. A suggested form for recording data is shown in figure 10-7.

**6. Casing or cementing depths** — The depth of the casing or the cemented interval should be shown for each core run. Do not cement any more of the hole than is necessary to repair a caving or raveling interval. The use of additives such as calcium chloride or aluminum powder, if permitted, will reduce the set time. These materials should be added to the water and not to the cement.

**7. Recording unusual conditions** — All unusual conditions or events should be noted in the "Notes"

Drill Hole No. \_\_\_\_\_

### WATER TESTING RECORD

Date \_\_\_\_\_

Feature \_\_\_\_\_ Project \_\_\_\_\_

State \_\_\_\_\_

Type of Packer \_\_\_\_\_

Driller \_\_\_\_\_

Notes \_\_\_\_\_

Inspector \_\_\_\_\_

Test Section		Gauge Height or Gravity Surface	Packer Gas Pres. Enter "w" if loaded mechanically, "g" if gravity	Test Pres. Enter "g" if gravity	Shut in Pressure	Stab. Period	Water loss in gallons for each minute of test					Total loss in gallons
From	To						1	2	3	4	5	

Hole No. \_\_\_\_\_

Figure 10-7.—Water testing record.

CORE LOGGING

## FIELD MANUAL

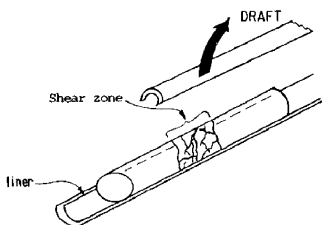
column of the report. This includes such items as sudden changes in drilling speed, loss of circulation, drop of drill string (open joints or cavities), casing and cementing procedures, caving, squeezing, packer failures, and gas.

**8. Recording setups, drilling, and downtime** — Time must be noted on reverse side of report. Type, number, and size of bit is indicated here also.

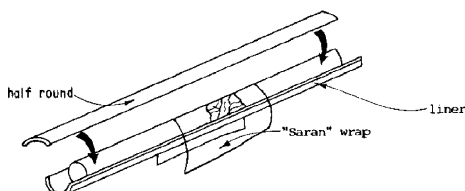
**9. Recording water level measurements** — Measurement should be recorded at the start of each day shift and shown on the day shift report. Holes should be jetted or bailed prior to completion of the hole to obtain reliable water level data. Immediately after jetting or bailing, the depth to water should be recorded.

**10. Care of core and core boxes** — Split-tube (triple tube) core barrels should be used. If not used, the core should not be damaged when extracted from the core barrel. Do not beat on the barrel with a metal hammer; use a rubber mallet/hammer or a piece of wood. The best way to remove core from a solid barrel is by using a pump to pressurize the inside of the barrel and extrude the core (stand back!). The mud pump will work satisfactorily for this. Core should be extracted from the inner tube and carefully placed into core boxes by hand. The use of cardboard or plastic halfrounds is recommended (see figure 10-8. Core pieces should be fitted into the core box and fragments should be arranged to save space. Long pieces may be broken for better fit in the core box, but a line should be drawn across the core to denote mechanical breaks. If 5-foot (1.5-m) core

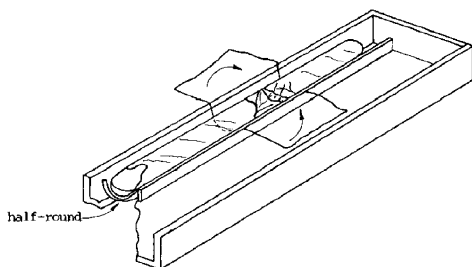
## CORE LOGGING



1. Remove upper split liner to expose fractured rock or shear zone.



2. Place "Saran" wrap over shear zone; then place half-round over top of core and wrap.



3. Take to core box, rotate liner, half-round and core 180° and place in core box; then wrap "Saran" wrap over top of core. An additional half-round may then be placed over the zone to protect it, or to write on. Shear zone may be lifted out of box as a unit if waxing of sample is desired.

**Figure 10-8.—Use of half-round to protect core.**

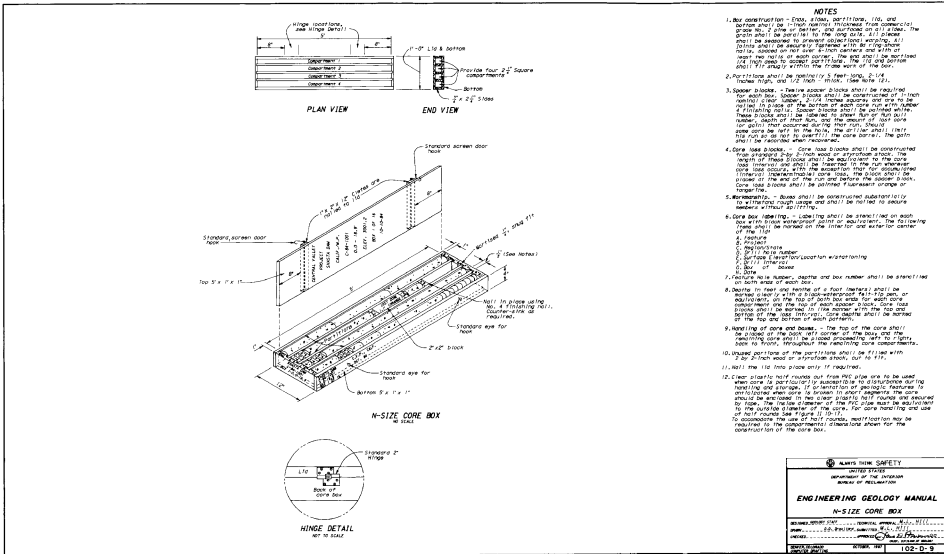
## FIELD MANUAL

boxes are used, mechanical breaks to fit 5-foot runs in boxes are reduced. Figure 10-9 shows a typical core box for N-size core.

Core should be placed in the core box from left to right, with the top to the left, bottom to the right, starting at the top of the box so the core reads like a book. The ends and top of the box should be marked with black enamel paint or indelible felt pen. Core blocks, which mark the depths, are placed between each run and the depth marked. Data on the outside of the left end of the box should include the project, feature, drill hole number, box number, and depth interval in the box.

Filler blocks (spacers) are necessary to properly record information and minimize disturbance to the core during handling. Blocks should be placed with a planed side marked with either black enamel paint or indelible felt-tip pen; 2- by 2-inch (50- by 50-mm) blocks work well for N-size core. All core runs must be separated with blocks properly labeled at the top and bottom of the run. Sample intervals should be marked in the boxes using wooden blocks of lengths equal to the missing core so that the sample may be returned to the box. Gaps for core losses should not be left in the core box. Core left in the hole and recovered on the next run may be added to the previous run. Filler blocks inserted where unaccountable core losses occur should show the length of loss in tenths of feet, as follows: LC (lost core) 0.3 foot, or NR (no recovery) 0.3 foot. The core loss block indicates that a certain length of core was unaccountably lost within a run, and the block should be placed at the depth of the core loss. If the point of core loss cannot be determined, the block can be placed in the core box at the bottom of





- NOTES**
1. Box construction - Ends, sides, partitions, lid, and bottom shall be 1/2 inch nominal thickness (nominal) galvanized sheet metal. The sheet shall be suitable to the long side. If 20 gauge sheet is necessary to prevent outward warping, all joints shall be double riveted. Particles with an average size of 1/2 inch or larger shall not be permitted to pass through the lid. The lid shall be suitable to support partitions. The lid and screen shall be placed within the frame work of the box.
  2. Partitions shall be galvanized 3 feet long, 2 1/4 inches high, and 2 1/2 inches wide (nominal).
  3. Spacer blocks - Two low spacer blocks shall be required for each hole. Spacer blocks shall be constructed of such material as copper, brass, or 1/4 inch aluminum and shall be drilled to the top of the screen on each side of the hole. These blocks shall be spaced to make the screen tight when inserted. The spacer blocks shall be spaced to make the screen tight when inserted. The spacer blocks shall be spaced to make the screen tight when inserted. The spacer blocks shall be spaced to make the screen tight when inserted.
  4. Core hole blocks - Core hole blocks shall be constructed from galvanized 3/16 inch wood or aluminum stock. The height of these blocks shall be adjusted to the core hole diameter and shall be fastened to the box with spacer blocks, with the exception that for unconfined cores of 1 1/2 inch diameter or less, the core hole block shall be placed at the top and below the spacer block. Core hole blocks shall be placed in alternate core compartments.
  5. Rivetmanship - Rivets shall be constructed substantially to a minimum, except where noted, and shall be placed to ensure freedom of fitting.
  6. Core box openings - Logging shall be permitted on each side with three rectangular joints or equivalent. The following openings shall be provided:
    - a. Entrance
    - b. Inspection
    - c. 1/2 inch diameter
    - d. 1/4 inch diameter
    - e. 1/2 inch diameter
    - f. 1/4 inch diameter
    - g. 1/2 inch diameter
  7. Location of the number, opening and box number shall be printed on both ends of each hole.
  8. Drilling in feet and inches of a full meter's shall be marked clearly on the sides of the box. The top of each hole shall be marked on the top of each spacer block. Core hole blocks shall be placed in the screen with the top and bottom of the hole indicated. Core holes shall be marked on the top of each partition.
  9. Marking of core and boxes - The top of the box shall be marked in feet and inches on the left side of the box. The hole size shall be marked on the right side of the box. The hole size shall be marked on the right side of the box. The hole size shall be marked on the right side of the box.
  10. Unconfined cores of the partition shall be placed with 2 1/2 inch wood or aluminum stock, cut to fit:
    - a. 1/2 inch the top hole shall fit required.
  11. Core shall be held in place by the spacer blocks. The spacer blocks shall be spaced to make the screen tight when inserted. The spacer blocks shall be spaced to make the screen tight when inserted.

Figure 10-9.—Standard N-size core

## FIELD MANUAL

## CORE LOGGING

the run, preceding the bottom of run block. Cavities may be marked on the block. All spacer, sample, and core loss blocks should be nailed to the bottom or sides of the box to prevent movement of the core.

At the drill site, core boxes should be lined up, preferably on boards or planks, in order from top to bottom, with labels and up side to left, in a safe area and kept covered with lids. While in the field, do not place boxes where sliding or caving of slopes is likely to occur and keep out of the way of vehicles and equipment. Core boxes, especially those containing soft, slaking, or intensely fractured core material, should be covered immediately to prevent damage by rain or drying. Tray partitions in boxes should be nailed so that nails do not protrude from bottom of boxes.

When the core is moved, be careful to prevent disturbance, breakage, or spilling. Damage to the core during transportation can be minimized by using nailed-down spacers and a 3/4- to 1-inch thick (19-25-mm) foam-rubber pad placed between the top of the core and the secured core box lid.

**Hole Completion.**—Completion of the drill hole should meet the requirements established by the exploration program and at the direction of the field geologist. Drill holes usually will be completed either with sufficient casing or plastic pipe to assure that the hole will stay open for later water level observations. In areas where vandalism may occur or when long-term monitoring is contemplated, a standpipe and suitable cap with lock should be installed. Completion information should be indicated on the driller's report. The drill hole number should be stamped or welded into the casing. If groundwater observation riser pipes have been installed,

## FIELD MANUAL

install a minimum 3-foot (1-m) length of surface casing with a locking cap as a standpipe to mark the drill hole and protect the riser pipe. Grouted in place, this standpipe can also serve to protect the observation well from infiltration by surface runoff.

### **Concrete Core Logging**

Concrete structures are commonly cored to assess the quality of concrete or as part of foundation investigations on existing features. An early macroscopic assessment of concrete core is warranted for the following reasons:

- Concrete physical condition may suggest changes in the drilling program or sampling techniques that would be difficult to modify after drilling is complete. A different approach in drilling or sampling techniques may be necessary to determine the cause of distress or failure.
- Shipping, handling, and sample preparation may modify the concrete core by inducing, modifying, or masking fractures or causing core disintegration.
- Core could be lost or destroyed before reaching the laboratory.
- Macroscopic examination may provide the required information eliminating the need for a petrographic examination.

This section is based on American Society for Testing Materials Designations (ASTM) C 823-83 and C 856-83.

**Purposes of Examination.**—Investigations of in-service concrete conditions are usually done to: (a) determine the ability of the concrete to perform

## CORE LOGGING

satisfactorily under anticipated conditions for future service; (b) identify the processes or materials causing distress or failure; (c) discover conditions in the concrete that caused or contributed to satisfactory performance or failure; (d) establish methods for repair or replacement without recurrence of the problem; (e) determine conformance to construction specification requirements; (f) evaluate the performance of the components in the concrete; and (g) develop data for fixing financial and legal responsibility.

In addition to the usual drill log information, the following should be provided, if available:

- Reason for and objectives of the coring program.
- Location and original orientation of each core.
- Conditions of operation and service exposure.
- Age of the structure.
- Results of field tests, such as velocity and rebound or Schmidt hammer data.

Figure 10-10 is an example of a drill hole log showing the types of information that can be shown and a format for a log showing both rock and concrete core.

**Examination.**—Concrete core is commonly marked in the field showing the top and bottom depths at the appropriate ends and at any of the following features. Below are listed the major items to examine and record:

**Fractures** — Cracks or fractures in core are best seen on smooth surfaces and can be accented by wetting and partial drying of the surface. Old crack surfaces are often different colors than fresh fracture

# CORE LOGGING

GEOLOGIC LOG OF DRILL HOLE NO. DH-101		SHEET 1 OF 2																																																																																		
FEATURE: EAST PARK DAM - SEED LOCATION: SEE NOTES BEGIN: 03-17-68 FINISHED: 03-22-68 DEPTH AND ELEV. OF WATER LEVEL AND DATE MEASURED: 0.3 (1199.20)	PROJECT: ORLAND PROJECT COORDINATES: N 819981 E 1895161 TOTAL DEPTH: 36.1 ft DEPTH TO BEDROCK: 16.6 ft	STATE: CALIFORNIA GROUND ELEVATION: 1199.5 ANGLE FROM HORIZON: 90 BEARING: HOLE LOGGED BY: STEVEN SHERER REVIEWED BY:																																																																																		
NOTES	PERMEABILITY TESTS	FIELD VISUAL CLASSIFICATION AND PHYSICAL CONDITION	DEPTH																																																																																	
<p>ALL MEASUREMENTS ARE IN FEET FROM GROUND SURFACE.</p> <p><b>DRILLED BY:</b> Regional Drill Crew, H. Jack Fry, Driller.</p> <p><b>PURPOSE OF HOLE:</b> To determine condition of sea concrete, lift line bonding and foundation/concrete contact, permeability and rock properties of bedrock.</p> <p><b>LOCATION OF HOLE:</b> 2.0 ft from southwest edge of sea crest; 50.5 ft from right abutment.</p> <p><b>DRILL RIG:</b> Soregus &amp; Herwood.</p> <p><b>DRILLING METHODS:</b> Drilled with clean water. 0.0 to 21.6 ft: Continuous coring with 6-inch dia. by 3 ft long core barrel and diamond bit, except: 21.1 to 21.8 ft: NQD-3 core barrel with diamond bit; refusal at 21.2 ft. Hole dia. 7 inches; core dia. 5.78 to 6.0 inches. 21.6 to 21.7 ft: NQD-3 core barrel with diamond bit; refusal at 21.7 ft. 21.7 to 22.8 ft: 3-inch casing. 22.8 to 35.1 ft: Continuous coring with NQD-3 core barrel with diamond bit and split inner barrel; hole dia. 2.98 inches; core dia. 1.76 inches.</p> <p><b>DRILLING CONDITIONS:</b> 0.0 to 21.1 ft: Slow and smooth with some roughness. 21.1 to 22.8 ft: Very rough with chatter; would not advance. 22.8 to 35.1 ft: Moderate speed and smooth.</p> <p><b>ESTIMATED DRILLING FLUID RETURN:</b> 0.0 to 16.6 ft: 100% gray. 16.6 to 35.1 ft: 100% dark gray.</p> <p><b>CASING RECORD:</b> Type: HQ casing. Casing: Dial. Interval Drilled (feet) -- 0.0 to 21.7 ft 22.8 22.8 to 35.1 ft</p> <p><b>DEPTH TO WATER DURING DRILLING:</b> (at start of</p>	<table border="1" style="width: 100%; border-collapse: collapse;"> <tr> <th style="width: 10%;">DEPTH (ft)</th> <th style="width: 10%;">PERMEABILITY (K VALUE)</th> <th style="width: 10%;">PRESSURE (PSI) UP/DOWN</th> <th style="width: 10%;">HELE TYPE/SIZE</th> <th style="width: 10%;">% RECOVERY</th> <th style="width: 10%;">CLASSIFICATION</th> <th style="width: 10%;">DEPTH (ft)</th> </tr> <tr> <td>0</td> <td></td> <td></td> <td></td> <td></td> <td></td> <td>0.0 to 16.6 ft: CONCRETE.</td> </tr> <tr> <td>5</td> <td>2.29 x 10<sup>-5</sup></td> <td>0</td> <td>6" D</td> <td>.1</td> <td></td> <td rowspan="10"> <p><b>About 65% BY VOLUME</b> igneous, metamorphic and sedimentary aggregate. About 60% of aggregate is subangular to well rounded, spherical and tabular. Fine and coarse gravel; about 80% angular to subrounded, medium to coarse sand; about 8% subrounded to well rounded, spherical to tabular cobbles. Some amorphous gravel and cobble pieces are oxidized around outer 1/4 inch. Some secondary siliceous oxides to intensely weathered. Occasional small 1/8 to 1/2 inch diameter tree branch fragments throughout and small bits of plant material are common. About 35% BY VOLUME fine-grained, gray-colored sand/cement matrix with few to many scattered air vesicles ranging from 1/8 to 1 inch, mostly 1/8 to 1/4 inch, maximum aggregate size 6 inches. Moderately soft to moderately hard, easy to moderately easy to groove matrix with knife; poorly to well bonded and unstrained except as noted. See "COMMENTS" below for explanation of abbreviation.</p> <p><b>DEPTH</b> 0.25 ft: LL 2; not bonded, water flowing into hole, and out downhole face of case. 2.6 ft: AA, Btc. 4.4 ft: AA, MB. 6.2 ft: AA, MB. 7.8 ft: LL 2, MB; soft and broken into pieces, water seeping on downhole sea face. 8.6 ft: AA, Btc. 8.9 to 10.7 ft: Many small air vesicles. 10.7 ft: AA, Btc. 0.4 ft (10.8 in) conglomerate piece in concrete. 12.5 ft: LL 2 measured on face of core, but not seen in core. 12.6 ft: AA, MB; 1/4 to 1 inch piece of wood at 12.6 ft. 12.6 to 14.4 ft: Many small air vesicles. 14.4 ft: AA, MB. 14.7 to 16.6 ft: Many small air vesicles. 16.6 ft: Contact of concrete with conglomerate bedrock is well-bonded, irregular surface.</p> <p><b>16.6 to 35.1 ft: UPPER JURASSIC/LOWER CRETACEOUS STONY CREEK FORMATION</b></p> <p>Conglomerate. Light gray-brown to dark gray and green. Composed chiefly of well-rounded to subrounded, spherical to tabular, coarse sand- to cobble-size rock fragments of chert, quartzite, quartz and serpenite in dark gray ferruginous and argillaceous cementation. Texture is about 80% rock fragments and about 10% cementing matrix. Rock fragments composed of approximately 80% predominantly fine and coarse gravel and about 20% coarse sand. Thickly bedded with 1- to 2.3-ft thick fining upward sequence to massive. Intensely to moderately weathered. Dark gray to dark brown with moderate to heavy oxide staining throughout cementation. Moderately hard to moderately soft. Core</p> </td> </tr> <tr> <td>6</td> <td></td> <td></td> <td></td> <td></td> <td></td> </tr> <tr> <td>10</td> <td></td> <td></td> <td></td> <td></td> <td></td> </tr> <tr> <td>15</td> <td></td> <td></td> <td></td> <td></td> <td></td> </tr> <tr> <td>20</td> <td></td> <td></td> <td></td> <td></td> <td></td> </tr> <tr> <td>25</td> <td></td> <td></td> <td></td> <td></td> <td></td> </tr> <tr> <td>30</td> <td></td> <td></td> <td></td> <td></td> <td></td> </tr> <tr> <td>35</td> <td></td> <td></td> <td></td> <td></td> <td></td> </tr> <tr> <td>40</td> <td></td> <td></td> <td></td> <td></td> <td></td> </tr> <tr> <td>45</td> <td></td> <td></td> <td></td> <td></td> <td></td> </tr> <tr> <td>50</td> <td></td> <td></td> <td></td> <td></td> <td></td> </tr> </table>	DEPTH (ft)	PERMEABILITY (K VALUE)	PRESSURE (PSI) UP/DOWN	HELE TYPE/SIZE	% RECOVERY	CLASSIFICATION	DEPTH (ft)	0						0.0 to 16.6 ft: CONCRETE.	5	2.29 x 10 <sup>-5</sup>	0	6" D	.1		<p><b>About 65% BY VOLUME</b> igneous, metamorphic and sedimentary aggregate. About 60% of aggregate is subangular to well rounded, spherical and tabular. Fine and coarse gravel; about 80% angular to subrounded, medium to coarse sand; about 8% subrounded to well rounded, spherical to tabular cobbles. Some amorphous gravel and cobble pieces are oxidized around outer 1/4 inch. Some secondary siliceous oxides to intensely weathered. Occasional small 1/8 to 1/2 inch diameter tree branch fragments throughout and small bits of plant material are common. About 35% BY VOLUME fine-grained, gray-colored sand/cement matrix with few to many scattered air vesicles ranging from 1/8 to 1 inch, mostly 1/8 to 1/4 inch, maximum aggregate size 6 inches. Moderately soft to moderately hard, easy to moderately easy to groove matrix with knife; poorly to well bonded and unstrained except as noted. See "COMMENTS" below for explanation of abbreviation.</p> <p><b>DEPTH</b> 0.25 ft: LL 2; not bonded, water flowing into hole, and out downhole face of case. 2.6 ft: AA, Btc. 4.4 ft: AA, MB. 6.2 ft: AA, MB. 7.8 ft: LL 2, MB; soft and broken into pieces, water seeping on downhole sea face. 8.6 ft: AA, Btc. 8.9 to 10.7 ft: Many small air vesicles. 10.7 ft: AA, Btc. 0.4 ft (10.8 in) conglomerate piece in concrete. 12.5 ft: LL 2 measured on face of core, but not seen in core. 12.6 ft: AA, MB; 1/4 to 1 inch piece of wood at 12.6 ft. 12.6 to 14.4 ft: Many small air vesicles. 14.4 ft: AA, MB. 14.7 to 16.6 ft: Many small air vesicles. 16.6 ft: Contact of concrete with conglomerate bedrock is well-bonded, irregular surface.</p> <p><b>16.6 to 35.1 ft: UPPER JURASSIC/LOWER CRETACEOUS STONY CREEK FORMATION</b></p> <p>Conglomerate. Light gray-brown to dark gray and green. Composed chiefly of well-rounded to subrounded, spherical to tabular, coarse sand- to cobble-size rock fragments of chert, quartzite, quartz and serpenite in dark gray ferruginous and argillaceous cementation. Texture is about 80% rock fragments and about 10% cementing matrix. Rock fragments composed of approximately 80% predominantly fine and coarse gravel and about 20% coarse sand. Thickly bedded with 1- to 2.3-ft thick fining upward sequence to massive. Intensely to moderately weathered. Dark gray to dark brown with moderate to heavy oxide staining throughout cementation. Moderately hard to moderately soft. Core</p>	6						10						15						20						25						30						35						40						45						50						<p><b>PERCOLATION TESTS:</b> Gravity water loss tests were conducted using an inflatable packer. No packer used during 0.0- to 10.7-foot test interval.</p> <p><b>EXPLANATION OF SYMBOLS USED IN DESCRIPTION OF CONCRETE:</b>                      AA: Breaks around aggregate.                      T&amp;A: Breaks through and around aggregate.                      LL: Lift line.                      MB: Mechanical break, not at bottom of core run.                      Btm: Break at bottom of core run.                      AG: Breaks around gravel in conglomerate.</p>	<p>6" D: 6-inch dia., by 3ft long core barrel and diamond bit.                      NQD-3: NQD-3 core barrel with diamond bit.                      3"CS: 3-inch casing.</p> <p><b>Definition of Bonding:</b>                      Well bonded: No to few small air vesicles; no separation of concrete along lift line; well consolidated.                      Moderately well bonded: No to a few small air vesicles; separates along lift line; well consolidated.                      Poor bonding: Large and/or numerous air vesicles at contact; easy to separate along lift line; soft concrete mortar or absence of concrete mortar.</p>
DEPTH (ft)	PERMEABILITY (K VALUE)	PRESSURE (PSI) UP/DOWN	HELE TYPE/SIZE	% RECOVERY	CLASSIFICATION	DEPTH (ft)																																																																														
0						0.0 to 16.6 ft: CONCRETE.																																																																														
5	2.29 x 10 <sup>-5</sup>	0	6" D	.1		<p><b>About 65% BY VOLUME</b> igneous, metamorphic and sedimentary aggregate. About 60% of aggregate is subangular to well rounded, spherical and tabular. Fine and coarse gravel; about 80% angular to subrounded, medium to coarse sand; about 8% subrounded to well rounded, spherical to tabular cobbles. Some amorphous gravel and cobble pieces are oxidized around outer 1/4 inch. Some secondary siliceous oxides to intensely weathered. Occasional small 1/8 to 1/2 inch diameter tree branch fragments throughout and small bits of plant material are common. About 35% BY VOLUME fine-grained, gray-colored sand/cement matrix with few to many scattered air vesicles ranging from 1/8 to 1 inch, mostly 1/8 to 1/4 inch, maximum aggregate size 6 inches. Moderately soft to moderately hard, easy to moderately easy to groove matrix with knife; poorly to well bonded and unstrained except as noted. See "COMMENTS" below for explanation of abbreviation.</p> <p><b>DEPTH</b> 0.25 ft: LL 2; not bonded, water flowing into hole, and out downhole face of case. 2.6 ft: AA, Btc. 4.4 ft: AA, MB. 6.2 ft: AA, MB. 7.8 ft: LL 2, MB; soft and broken into pieces, water seeping on downhole sea face. 8.6 ft: AA, Btc. 8.9 to 10.7 ft: Many small air vesicles. 10.7 ft: AA, Btc. 0.4 ft (10.8 in) conglomerate piece in concrete. 12.5 ft: LL 2 measured on face of core, but not seen in core. 12.6 ft: AA, MB; 1/4 to 1 inch piece of wood at 12.6 ft. 12.6 to 14.4 ft: Many small air vesicles. 14.4 ft: AA, MB. 14.7 to 16.6 ft: Many small air vesicles. 16.6 ft: Contact of concrete with conglomerate bedrock is well-bonded, irregular surface.</p> <p><b>16.6 to 35.1 ft: UPPER JURASSIC/LOWER CRETACEOUS STONY CREEK FORMATION</b></p> <p>Conglomerate. Light gray-brown to dark gray and green. Composed chiefly of well-rounded to subrounded, spherical to tabular, coarse sand- to cobble-size rock fragments of chert, quartzite, quartz and serpenite in dark gray ferruginous and argillaceous cementation. Texture is about 80% rock fragments and about 10% cementing matrix. Rock fragments composed of approximately 80% predominantly fine and coarse gravel and about 20% coarse sand. Thickly bedded with 1- to 2.3-ft thick fining upward sequence to massive. Intensely to moderately weathered. Dark gray to dark brown with moderate to heavy oxide staining throughout cementation. Moderately hard to moderately soft. Core</p>																																																																														
6																																																																																				
10																																																																																				
15																																																																																				
20																																																																																				
25																																																																																				
30																																																																																				
35																																																																																				
40																																																																																				
45																																																																																				
50																																																																																				
<p><b>COMMENTS:</b></p>		<p>SHEET 1 OF 2 DRILL HOLE DH-101</p>																																																																																		

**Figure 10-10.—Log of concrete and rock core.**

## CORE LOGGING

surfaces. Old fracture surfaces often have reaction products or alteration of the surfaces. Fractures often follow structural weaknesses.

**Reacted particles** — Rims on gravel or sand are often caused by weathering processes unless other factors indicate chemical reactions with the cement paste. Crushed aggregate with rims probably is due to chemical reaction with the cement paste.

**Reaction products** — Crushed aggregate with rims usually indicates alteration in the concrete, such as alkali-silica reaction or alkali-carbonate reaction. Rims in paste bordering coarse aggregate and light colored areas in the paste may be gel-soaked or highly carbonated paste adjoining carbonate aggregate that has undergone an alkali-carbonate reaction. White areas of fairly hard, dry material or soft, wet material that has fractured and penetrated the concrete and aggregate or fills air voids should be recorded. Alkali aggregate reaction products can be differentiated from calcium carbonate deposits by using hydrochloric acid. The reaction products do not fizz.

**Changes in size or type of fine and coarse aggregate** — Sizes, shapes, and types of aggregate can vary in a structure due to changes in mixes, placement procedure, or sources and should be logged.

**Voids** — Voids (honeycomb, popcorn) are indicators of trapped air, inadequate vibration, or insufficient mortar to effectively fill the spaces among coarse aggregate particles. Voids should be described and the volume percent estimated.

## FIELD MANUAL

**Segregation of components** — Concrete components can become segregated or concentrated during placement. Large aggregate sizes can separate from fine aggregate, and paste can separate from the aggregate, especially near forms or finished surfaces.

**Cold joints or lift lines** — Weak joints or zones can form in concrete due to long periods between buckets or mixer loads. Poor vibration or poor or improper preparation of previous lift surfaces can form zones of weakness or actual planes similar to joints in rock. These surfaces, called lift lines, should be described and any material on the surfaces described. Lift lines can be very subtle and difficult to locate. Design or construction data often provide clues as to where to look for lift lines and construction joints. The core should be examined wet. Clues to lift line locations are: (1) aligned aggregate along the surfaces each side of a line, (2) coarser aggregate above the lift line than is below the line, (3) different shape, gradation, or composition of aggregate above and below the lift line, (4) a thin line of paste on the lift line, and (5) no aggregate crosses the lift line.

**Steel or other imbedded items** — Reinforcing steel and orientations should be described as well as other materials encountered such as timber, steel lagging, dirt, or cooling pipes.

**Changes in color of the cement** — Changes in paste color can indicate reaction products or changes in cement type or cement sources and should be logged.

**Aggregate-paste bond** — The bond between the aggregate and cement should be described. A good bond is characterized by concrete breaking through



## CORE LOGGING

the aggregate and not around the particles. A fair bond is characterized by concrete breaking through and around the aggregate. A poor bond has concrete breaking around the aggregate.

**Aggregate rock type** — The aggregate rock type can be important in determining the causes of concrete problems. For example, limestone often has chert inclusions suggesting an aggregate reaction, whereas an igneous rock such as granite probably will not react with cement. Both the coarse and fine aggregate should be examined.

**Aggregate shape** — Aggregate shape is usually unique to each source. Rounded or subrounded aggregate is probably natural. Angular (sharp) aggregate is probably crushed.

**Mechanical breaks** — Mechanical breaks in the core and whether the break is around or through the aggregate should be noted.



## Chapter 11

# INSTRUCTIONS FOR LOGGING SOILS

### General

All subsurface investigations of soils for construction materials and for most engineering purposes using test pits, trenches, auger holes, drill holes, or other exploratory methods should be logged and described using the standards in USBR 5000 [1] and 5005 [1] (Unified Soil Classification System [USCS]) in accordance with the established descriptive criteria and descriptors presented in chapter 3 and the guidelines presented in this section.

All investigations associated with land classification for irrigation suitability, as well as data collection and analyses of soil and materials related to drainage investigations, should be logged and described using the U.S. Department of Agriculture terminology outlined in appendix I to *Agriculture Handbook No. 436* (Soil Taxonomy), dated December 1975 [2].

Test pits and auger holes may be logged on a form (figure 11-1), or logs may be computer generated. For metric design studies and specifications, information is to be in metric units. For specifications using English units, the written soil description should use metric units for the description of soil particle sizes (millimeters instead of inches). Example word descriptions are shown in figures 11-2 through 11-11.

# FIELD MANUAL

7-1336-A (1-86) Bureau of Reclamation	<b>LOG OF TEST PIT OR AUGER HOLE</b>	HOLE NO. _____									
FEATURE _____ PROJECT _____ AREA DESIGNATION _____ GROUND ELEVATION _____ COORDINATES N _____ E _____ METHOD OF EXPLORATION _____ APPROXIMATE DIMENSIONS _____ LOGGED BY _____ DEPTH WATER ENCOUNTERED 1/ _____ DATE _____ DATE(S) LOGGED _____											
CLASSIFICATION GROUP SYMBOL <small>(describe sample taken)</small>	CLASSIFICATION AND DESCRIPTION OF MATERIAL  SEE USBR 5000, 5005	% PLUS 3 in (BY VOLUME) <table style="margin-left: auto; margin-right: auto;"> <tr> <td style="border: 1px solid black; padding: 2px;">3</td> <td style="border: 1px solid black; padding: 2px;">5</td> <td style="border: 1px solid black; padding: 2px;">PLUS</td> </tr> <tr> <td style="border: 1px solid black; padding: 2px;">5</td> <td style="border: 1px solid black; padding: 2px;">12</td> <td style="border: 1px solid black; padding: 2px;">12</td> </tr> <tr> <td style="border: 1px solid black; padding: 2px;">in</td> <td style="border: 1px solid black; padding: 2px;">in</td> <td style="border: 1px solid black; padding: 2px;">in</td> </tr> </table>	3	5	PLUS	5	12	12	in	in	in
3	5	PLUS									
5	12	12									
in	in	in									
REMARKS:											

1/ Report to nearest 0.1 foot.

GPO 849-388

Figure 11-1.—Log of test pit or auger hole.

# LOGGING SOILS

1-1336-A (1-66) Bureau of Reclamation		LOG OF TEST PIT OR AUGER HOLE	HOLE NO. _____	
FEATURE _____		PROJECT _____		
AREA DESIGNATION _____		GROUND ELEVATION _____		
COORDINATES N _____ E _____		METHOD OF EXPLORATION _____		
APPROXIMATE DIMENSIONS _____		LOGGED BY _____		
DEPTH WATER ENCOUNTERED 1/ _____ DATE _____		DATE(S) LOGGED _____		
CLASSIFICATION GROUP SYMBOL (describe sample taken)	CLASSIFICATION AND DESCRIPTION OF MATERIAL  SEE USBR 8000, 8005	% PLUS 3 in (BY VOLUME)		
		3- 8 in	8- 12 in	PLUS 12 in
GM  5.2 ft	0.0 to 5.2 ft WELL-GRADED GRAVEL WITH SAND: About 70% coarse to fine, hard, subangular gravel; about 30% coarse to fine, hard, subangular sand; trace of fines; maximum size, 75 mm; moist, brown; hard to auger; no reaction with HCl.			
SP  10.5 ft	5.2 to 10.5 ft POORLY GRADED SAND: About 95% fine to medium sand; about 5% fines; maximum size, medium sand; wet, yellow brown; hard to auger; weak reaction with HCl.			
GP  17.6 ft	10.5 to 17.6 ft POORLY GRADED GRAVEL WITH SAND: About 60% predominantly fine, hard, subangular to subrounded gravel; about 40% predominantly fine sand; trace of fines; maximum size, 40 mm; dry, tan; hard to auger; no reaction with HCl.			
SW  25.3 ft	17.6 to 25.3 ft WELL-GRADED SAND: About 85% coarse to fine, hard, subangular sand; about 10% coarse to fine, hard, subrounded gravel (about 1/3 of gravel particles are flat); about 5% fines; maximum size, 40 mm; wet, brown; hard to auger; weak reaction with HCl.			
REMARKS:				

1/ Report to nearest 0.1 foot

GPO 848-361

Figure 11-2.—Clean coarse-grained soils.

# FIELD MANUAL

7-1336 A (1-86) Bureau of Reclamation	<b>LOG OF TEST PIT OR AUGER HOLE</b>	HOLE NO. _____		
FEATURE _____ PROJECT _____ AREA DESIGNATION _____ GROUND ELEVATION _____ COORDINATES N _____ E _____ METHOD OF EXPLORATION _____ APPROXIMATE DIMENSIONS _____ LOGGED BY _____ DEPTH WATER ENCOUNTERED $\frac{1}{2}$ _____ DATE _____ DATE(S) LOGGED _____				
CLASSIFICATION GROUP SYMBOL (describe sample taken)	CLASSIFICATION AND DESCRIPTION OF MATERIAL  SEE USBR 5000, 5005	% PLUS 3 in (BY VOLUME)		
		3 - 5 in	5 - 12 in	PLUS 12 in
CL    4.3 ft	0.0 to 4.3 ft LEAN CLAY: About 90% fines with medium plasticity, high dry strength, medium toughness; about 10% predominantly fine sand; maximum size, coarse sand; moist, brown; hard to auger; no reaction with HCl.			
ML    11.0 ft	4.3 to 11.0 ft SANDY SILT: About 70% nonplastic fines, rapid dilatancy, no dry strength; about 30% fine sand; maximum size, fine sand; wet, gray, faint organic odor; some roots present, easy to auger; weak reaction with HCl.			
CH    17.7 ft	11.0 to 17.7 ft FAT CLAY: About 90% fines with high plasticity, high to very high dry strength, high toughness; about 10% medium to fine sand; trace of gravel; maximum size, 20 mm; dry, reddish-brown; hard to auger; strong reaction with HCl.			
MH    25.5 ft	17.7 to 25.5 ft ELASTIC SILT: About 100% fines with low to medium plasticity, slow dilatancy, medium dry strength, low to medium toughness; trace of fine sand; maximum size, fine sand; wet, black; easy to auger; weak reaction with HCl.			
REMARKS				

$\frac{1}{2}$  Report to nearest 0.1 foot

CPD 847-120

Figure 11-3.—Fine-grained soils.

# LOGGING SOILS

7-1336 A (1-84) Bureau of Reclamation		LOG OF TEST PIT OR AUGER HOLE		HOLE NO. _____	
FEATURE _____		PROJECT _____			
AREA DESIGNATION _____		GROUND ELEVATION _____			
COORDINATES N _____ E _____		METHOD OF EXPLORATION _____			
APPROXIMATE DIMENSIONS _____		LOGGED BY _____			
DEPTH WATER ENCOUNTERED 1/ _____ DATE _____		DATE(S) LOGGED _____			
CLASSIFICATION GROUP SYMBOL <small>(describe sample taken)</small>	CLASSIFICATION AND DESCRIPTION OF MATERIAL  SEE USBR 8000, 8006	% PLUS 3 in (BY VOLUME)			
		3- 8 in	8- 12 in	PLUS 12 in	
GM  (lab classif.)  three sack samples  3.2 ft	0.0 to 3.2 ft WELL-GRADED GRAVEL WITH SAND: Sample had 64% coarse to fine, hard, subangular gravel; 34% coarse to fine, hard, subangular sand; 2% fines; maximum size, 75 mm; no reaction with HCl; Cu = 24, Cc = 1.8  IN-PLACE CONDITION: Homogeneous, moist, brown  Three 50-lbm sack samples taken for testing from 18-inch-wide sampling trench for entire depth interval on east side of trench. Samples were mixed and quartered.				
CL  (lab classif.)  one sack sample  7.6 ft	3.2 to 7.6 ft LEAN CLAY WITH SAND: Sample had 84% fines; 16% predominantly fine sand; maximum size, coarse sand; no reaction with HCl; LL = 36, PI = 19.  IN-PLACE CONDITION: Firm, homogeneous, moist, yellowish-brown.  One 40 lbm sack sample taken for testing from 12-inch-wide sampling trench from 4.7 to 6.8 ft depth.				
REMARKS					

1. Report to nearest 0.1 foot

GPO 849-381

Figure 11-4.—Soil classifications based on laboratory test data.

# FIELD MANUAL

7-1336-A (1-66) Bureau of Reclamation	<b>LOG OF TEST PIT OR AUGER HOLE</b>	NO. NO. _____						
FEATURE _____ PROJECT _____ AREA DESIGNATION _____ GROUND ELEVATION _____ COORDINATES N _____ E _____ METHOD OF EXPLORATION _____ APPROXIMATE DIMENSIONS _____ LOGGED BY _____ DEPTH WATER ENCOUNTERED $\frac{1}{2}$ _____ DATE _____ DATE(S) LOGGED _____								
CLASSIFICATION GROUP SYMBOL (describe sample taken)	CLASSIFICATION AND DESCRIPTION OF MATERIAL  SEE USBR 6000, 6005	% PLUS 3 in (BY VOLUME)						
		<table border="1" style="width: 100%; border-collapse: collapse;"> <tr> <td style="width: 33%; text-align: center;">3-5</td> <td style="width: 33%; text-align: center;">PLUS</td> <td style="width: 33%; text-align: center;">12 12</td> </tr> <tr> <td style="text-align: center;">in</td> <td></td> <td style="text-align: center;">in</td> </tr> </table>	3-5	PLUS	12 12	in		in
3-5	PLUS	12 12						
in		in						
SC  two sack samples         9.8 ft	0.0 to 9.8 ft CLAYEY SAND WITH GRAVEL: About 50% coarse to fine, hard, subangular to subrounded sand; about 25% fine, hard, subangular to subrounded gravel; about 25% fines with medium plasticity, high dry strength, medium toughness; maximum size, 20 mm; wet, reddish-brown; easy to auger; weak reaction with HCl.  Two 50 lbm sack samples obtained by mixing and quartering entire interval.							
	Other typical descriptions of sampling:  One 40-lbm sack sample is all soil removed in top 2.5 ft of interval. One 40-lbm sack sample is all soil removed from bottom 2.0 ft of interval.  One 50-lbm sack sample obtained by mixing and quartering all soil removed from 3.4 to 7.2 ft in interval.							
REMARKS								

$\frac{1}{2}$  Report to nearest 0.1 foot

OFC 849-22

Figure 11-5.—Auger hole with samples taken.



# LOGGING SOILS

7-13 4-A (1-86) Bureau of Reclamation		LOG OF TEST PIT OR AUGER HOLE	HOLE NO. _____		
FEATURE _____ AREA DESIGNATION _____ COORDINATES N _____ E _____ APPROXIMATE DIMENSIONS _____ DEPTH WATER ENCOUNTERED $\frac{1}{2}$ _____ DATE _____		PROJECT _____ GROUND ELEVATION _____ METHOD OF EXPLORATION _____ LOGGED BY _____ DATE(S) LOGGED _____			
CLASSIFICATION GROUP SYMBOL <small>(describe sample taken)</small>	CLASSIFICATION AND DESCRIPTION OF MATERIAL  <small>SEE USBR 9000, 9005</small>	% PLUS 3 in (BY VOLUME)			
		3 - 8 in	8 - 12 in	PLUS 12 in	
GP (visual) GW (lab classif.)  three sack samples   3.2 ft	0.0 to 3.2 ft POORLY GRADED GRAVEL WITH SAND: About 70% coarse to fine, hard, subangular gravel; about 30% coarse to fine, hard, subangular sand; trace of fines; maximum size, 75 mm; no reaction with HCl.  IN-PLACE CONDITION: Homogeneous, moist, brown  LAB TEST DATA: 64% gravel, 34% sand, 2% fines, Cu = 24, Cc = 1.8. Laboratory classification is WELL-GRADED GRAVEL WITH SAND.  Three 50-lbm sack samples taken for testing from 18-inch-wide sampling trench for entire depth interval on east side of trench. Samples were mixed and quartered.				
CL (lab classif.)  one sack sample  7.6 ft	3.2 to 7.6 ft LEAN CLAY: About 90% fines with medium plasticity, high dry strength, medium toughness; about 10% predominantly fine sand; maximum size coarse sand; no reaction with HCl.  IN-PLACE CONDITION: Firm, homogeneous, moist, yellowish-brown.  LAB TEST DATA: 84% fines, 16% sand, LL = 36, PI = 19  One 40-lbm sack sample taken for testing from 12-inch-wide sampling trench from 4.7 to 6.8 ft depth.				
REMARKS					

$\frac{1}{2}$  Report to nearest 0.1 foot

GPO 848-371

Figure 11-6.—Reporting laboratory classification in addition to visual classification.

# FIELD MANUAL

7-1936-A (1-64) Bureau of Reclamation	<b>LOG OF TEST PIT OR AUGER HOLE</b>	HOLE NO. _____			
FEATURE _____ PROJECT _____		GROUND ELEVATION _____			
AREA DESIGNATION _____		METHOD OF EXPLORATION _____			
COORDINATES N _____ E _____		LOGGED BY _____			
APPROXIMATE DIMENSIONS _____		DATE (B) LOGGED _____			
DEPTH WATER ENCOUNTERED 1/ _____		DATE _____			
CLASSIFICATION GROUP SYMBOL  (describe sample taken)	CLASSIFICATION AND DESCRIPTION OF MATERIAL  SEE USBR 8000, 8005	% PLUS 3 in (BY VOLUME)			
		3 - 8 in	8 - 12 in	PLUS 12 in	
CL         4.2 ft	0.0 to 4.2 ft LEAN CLAY: About 90% fines with medium plasticity, high dry strength, medium toughness; about 10% predominantly fine sand; maximum size, medium sand; strong reaction with HCl.  IN-PLACE CONDITION: Soft, homogeneous, wet, brown  GEOLOGIC INTERPRETATION: highly weathered Niobrara formation				
SC         9.8 ft	4.2 to 9.8 ft CLAYEY SAND WITH GRAVEL: About 50% coarse to fine, hard, subangular to subrounded sand; about 25% fine, hard, subangular to subrounded gravel; about 25% fines with medium plasticity, high dry strength, medium toughness; maximum size, 20 mm; weak reaction with HCl.  IN-PLACE CONDITION: Firm, homogeneous except for occasional lenses of clean fine sand 1/4 inch to 1 inch thick, moist, reddish-brown  GEOLOGIC INTERPRETATION: alluvial fan				
REMARKS					

1/ Report to nearest 0.1 foot

Figure 11-7.—Undisturbed soils.

# LOGGING SOILS

7-1336-A (1-58) Bureau of Reclamation	<b>LOG OF TEST PIT OR AUGER HOLE</b>	HOLE NO. _____		
FEATURE _____	PROJECT _____			
AREA DESIGNATION _____	GROUND ELEVATION _____			
COORDINATES N _____ E _____	METHOD OF EXPLORATION _____			
APPROXIMATE DIMENSIONS _____	LOGGED BY _____			
DEPTH WATER ENCOUNTERED 1/ _____ DATE _____	DATE(S) LOGGED _____			
CLASSIFICATION GROUP SYMBOL (describe sample taken)	CLASSIFICATION AND DESCRIPTION OF MATERIAL  SEE USBR 9000, 9005	% PLUS 3 in. (BY VOLUME)		
		3 8 in.	6 12 in.	PLUS 12 in.
SM  3.1 ft	0.0 to 3.1 ft SILTY SAND: About 70% coarse to fine, hard, angular sand; about 25% nonplastic fines, rapid dilatancy, no dry strength; about 5% fine, hard, angular gravel; maximum size, 10 mm; moist, brown, faint organic odor; some roots present, easy to auger; no reaction with HCl.			
GC  6.7 ft	3.1 to 6.7 ft CLAYEY GRAVEL: About 75% coarse to fine, hard, subrounded gravel; about 15% fines with medium plasticity, high dry strength, medium toughness; about 10% coarse, hard, subrounded sand; maximum size, 75 mm; dry, brown; hard to auger; strong reaction with HCl.			
SC  9.8 ft	6.7 to 9.8 ft CLAYEY SAND WITH GRAVEL: About 50% coarse to fine, hard, subangular to subrounded sand; about 25% fine, hard, subangular to subrounded gravel; about 25% fines with medium plasticity, high dry strength, medium toughness; maximum size, 20 mm; wet, reddish-brown; easy to auger; weak reaction with HCl.			
REMARKS				

1/ Report to nearest 0.1 foot.

GFC 84-1-1

Figure 11-8.—Coarse-grained soils with fines.



# LOGGING SOILS

Sheet 1 of 2

T. 1226 A (11-82) Bureau of Reclamation		LOG OF TEST PIT OR AUGER HOLE	HOLE NO. _____		
FEATURE _____		PROJECT _____			
AREA DESIGNATION _____		GROUND ELEVATION _____			
COORDINATES N _____ E _____		METHOD OF EXPLORATION _____			
APPROXIMATE DIMENSIONS _____		LOGGED BY _____			
DEPTH WATER ENCOUNTERED 1/ _____ DATE _____		DATE LOGGED _____			
CLASSIFICATION GROUP SYMBOL (NORTH AMERICAN)	CLASSIFICATION AND DESCRIPTION OF MATERIAL SEE USBR 5000, 5005	% PLUS 3 in. (BY VOLUME)			
		3	6	Plus	
in	in	in	in	in	
CL  In-place unit weight        4.3 ft	0.0 to 4.3 ft LEAN CLAY: About 50% fines with medium plasticity, high dry strength, medium toughness; about 10% predominantly fine sand; maximum size, coarse sand; no reaction with HCl.  IN-PLACE CONDITION: Firm, homogeneous, moist, reddish-brown  In-place dry unit weight and moisture from test at 3.0 to 3.7 ft: 112.0 lbf/ft <sup>3</sup> , 11.7%.				
GC  In-place unit weight        8.2 ft	4.3 to 8.2 ft CLAYEY GRAVEL WITH SAND: About 55% coarse to fine, hard, angular to subangular gravel (1/4 of gravel particles are flat or elongated); about 25% fines with medium plasticity, no dilatancy, high dry strength, medium toughness; about 20% predominantly fine sand; maximum size, 75 mm; weak to strong reaction with HCl.  IN-PLACE CONDITION: Firm, homogeneous, moist, brown  In-place dry unit weight and moisture from test at 6.2 to 7.0 ft  Total: 129.7 lbf/ft <sup>3</sup> , 13.2%  Minus No. 4: 107.8 lbf/ft <sup>3</sup> , 12.1% (90% compaction)  Max. Unit Weight, Opt.: 119.7 lbf/ft <sup>3</sup> , 11.0%				
REMARKS					

1. Report to nearest 0.1 foot.

DPL 7-81-22

Figure 11-10.—Reporting in-place density tests and percent compaction.

# FIELD MANUAL

7-1336-A (1-84) Bureau of Reclamation		LOG OF TEST PIT OR AUGER HOLE		HOLE NO. _____		
FEATURE _____		PROJECT _____				
AREA DESIGNATION _____		GROUND ELEVATION _____				
COORDINATES N _____ E _____		METHOD OF EXPLORATION _____				
APPROXIMATE DIMENSIONS _____		LOGGED BY _____				
DEPTH WATER ENCOUNTERED 1/ _____ DATE _____		DATE(S) LOGGED _____				
CLASSIFICATION GROUP SYMBOL <small>(describe sample taken)</small>	CLASSIFICATION AND DESCRIPTION OF MATERIAL  SEE USBR 5000, 8005	% PLUS 3 in (BY VOLUME)				
		3 - 5 in	5 - 12 in	PLUS 12 in		
(GW)scb	<p>0.0 to 7.4 ft WELL-GRADED GRAVEL WITH SAND, COBBLES, AND BOULDERS: About 70% coarse to fine, hard, subrounded gravel; about 30% coarse to fine, hard, subangular sand; trace of fines no reaction with HCl.</p> <p>TOTAL SAMPLE (BY VOLUME): 22% 3- to 5-inch hard, subrounded cobbles; 14% 5 to 12-inch hard, rounded cobbles; 2 percent plus 12-inch hard, subrounded boulders; remainder minus 3-inch; maximum dimension, 400 mm.</p> <p>IN-PLACE CONDITION: homogeneous, dry, brown</p> <p>GEOLOGIC INTERPRETATION: alluvial fan</p>	22	14	2		
7.4 ft						
REMARKS:						

1/ Report to nearest 0.1 foot

GPO 549-385

Figure 11-11.—Soil with measured percentages of cobbles and boulders.

## LOGGING SOILS

### Formats for Test Pits and Auger Hole Logs

#### General Instructions

The following subsection provides general instructions for log format and descriptions. Refer to chapter 3 for descriptive criteria, classification, and group names and symbols.

- Capitalize the group name. If cobbles and boulders are present, include them in the typical name.
- Describe plasticity of fines as:
  - “approximately 30 percent (%) fines with high plasticity”
  - “approximately 60% fines with low to medium plasticity”
  - “approximately 10% nonplastic fines”
- Give results of hand tests when performed.
- Use “reaction with hydrochloric acid (HCl).”
- Do not give unnecessary information such as “no odor,” “no gravel,” and “no fines.”

However, the negative result of a hand test is positive information and should be reported as “no dilatancy,” “nonplastic,” “no dry strength,” or “no reaction with HCl.”

For reporting maximum particle size, use the following:

Fine sand

Medium sand

Coarse sand

5-millimeter (mm) increments from 5 mm to 75 mm

25-mm increments from 75 mm to 300 mm

100-mm increments over 300 mm

## FIELD MANUAL

For example, “maximum particle size 35 mm” or “maximum particle size 400 mm” are the correct format and size increment.

Table 11-1 is a checklist for log descriptors. Format for descriptions, results, and other information are in the following subsections.

Table 11-1.—Checklist for the description of soils  
in test pit and auger hole logs

- 
1. Group symbol. - Capitalized and shown in the left-hand column.
  2. Depth. - Depths of interval classified, shown in either meters or feet and tenths of units in second column from the left.
  3. Identification of sample. - Type and size of sample and origin of sample, shown in third column from the left.
  4. Classification and description column. -
    - a. First paragraph. -
      - (1) Depth of interval classified
      - (2) Group name capitalized
      - (3) Percent of fines sand and gravel by weight (include trace amounts but not added to percentage which must equal 100 percent)
      - (4) Description of particles
        - (a) Particle size range: describe as either gravel - fine or coarse, or sand—fine, medium, or coarse
        - (b) Hardness of particles (coarse sand and larger)
        - (c) Particle angularity (angular, subangular, sub-rounded, or rounded)
        - (d) Particle shape (flat, elongated, or flat and elongated)
        - (e) Maximum particle size or dimension



## LOGGING SOILS

- (5) Description of fines
  - (a) Plasticity (nonplastic, low, medium, or high)
  - (b) Dilatancy (none, slow, or rapid)
  - (c) Dry strength (none, low, medium, high, or very high)
  - (d) Toughness (low, medium, or high)
- (6) Moisture condition (dry, moist, or wet)
- (7) Color (moist color)
- (8) Odor (mention only if organic or unusual)
- (9) Reaction with HCl (none, weak, or strong)
- b. TOTAL SAMPLE (BY VOLUME): second paragraph, if applicable - i.e., more than 50 percent plus 75-mm material
  - (1) Percent of cobbles and percent of boulders
  - (2) Same information as item 4.a (4)
- c. IN-PLACE CONDITION: third paragraph (second paragraph if less than 50 percent oversize)
  - (1) Consistency; fine-grained soils only (very soft, soft, firm, hard, or very hard)
  - (2) Structure (stratified, lensed, slickensided, blocky, fissured, homogeneous)
  - (3) Cementation (weak, moderate, strong)
  - (4) Moisture (if an in-place condition paragraph is included, moisture is not described in the first paragraph)
  - (5) Color (if an in-place condition paragraph is included, color is not described in the first paragraph)
  - (6) Result of in-place density and/or moisture tests
- d. GEOLOGIC INTERPRETATION: (fourth paragraph) geologic description including genetic name, stratigraphic name if known, and any local name.

## FIELD MANUAL

5. Remarks block. - Provide additional description or remarks such as root holes, other debris found, caving, degree of difficulty to auger or excavate, reason for refusal or reached predetermined depth, and water level information or hole completion.

---

Figure 11-12 is a field form for logging soils.

### Reporting by Method of Classification

Preparation of Logs Based on Visual Classification.—List fines, sand, and gravel in descending order of percent (must add up to 100 percent). For visual classification, estimate percentages to the closest 5 percent. Precede the estimated percentages with “approx.,” not “about.” If a component is present but is less than 5 percent of the total, use “trace.” “Trace” is not included in the 100 percent.

Preparation of Logs Based on Laboratory Classification.—When logs are prepared using laboratory classifications (based on laboratory tests), the information must be presented on the log as shown in figure 11-4. The difference between a laboratory and a visual classification is depicted in figure 11-6.

The visual classification should not be changed, nor should the estimated percentages, plasticity description, or the results of the hand tests (dry strength, dilatancy, and toughness) be changed to reflect laboratory tests results. The visual classification is based on the total material observed; whereas, the laboratory classification is based on a representative sample of the material.

# LOGGING SOILS

FIELD FORM—SOIL LOGGING

HOLE NO. \_\_\_\_\_

DATE \_\_\_\_\_ PROJECT \_\_\_\_\_ FEATURE \_\_\_\_\_  
AREA \_\_\_\_\_ DRILLER \_\_\_\_\_ LOGGED BY \_\_\_\_\_

-----  
**SAMPLE INTERVAL AND TYPE:**

Type \_\_\_\_\_ Moisture  
Sample \_\_\_\_\_ Sample  
Interval \_\_\_\_\_ Sample Weight (Lbs) \_\_\_\_\_ Interval \_\_\_\_\_

-----  
Typical Name \_\_\_\_\_  
Group Symbol \_\_\_\_\_

-----  
**SIZE DISTRIBUTION, CHARACTERISTICS:**

(5-mm increments from 5 to 75 mm, 255-mm increments from 75 to 300 mm, 100mm increments over 300 mm)

Boulders (>300 mm) \_\_\_% (vol.) Max. size (mm) \_\_\_ Hardness \_\_\_ Angularity \_\_\_\_\_

Cobbles (75-300 mm) \_\_\_% (vol.) Max. size (mm) \_\_\_ Hardness \_\_\_ Angularity \_\_\_\_\_

Gravel \_\_\_% Coarse (20-75 mm) \_\_\_ Fine (5-20 mm) \_\_\_ Hardness \_\_\_ Angularity \_\_\_

Sand \_\_\_% Coarse \_\_\_ Medium \_\_\_ Fine \_\_\_ Hardness \_\_\_ Angularity \_\_\_\_\_

Fines \_\_\_\_\_%

Plasticity: Nonplastic \_\_\_\_\_ Low \_\_\_\_\_ Medium \_\_\_\_\_ High \_\_\_\_\_

Dilatancy: No \_\_\_\_\_ Slow \_\_\_\_\_ Rapid \_\_\_\_\_

Dry Strength: No \_\_\_\_\_ Low \_\_\_\_\_ Medium \_\_\_\_\_ High \_\_\_\_\_ Very High \_\_\_\_\_

Toughness: Low \_\_\_\_\_ Medium \_\_\_\_\_ High \_\_\_\_\_

Maximum Size: Fine Sand \_\_\_\_\_ Medium Sand \_\_\_\_\_ Coarse Sand \_\_\_\_\_ mm

Moisture: Dry \_\_\_\_\_ Moist \_\_\_\_\_ Wet \_\_\_\_\_

Color \_\_\_\_\_ Odor \_\_\_\_\_ Organic Debris and Type \_\_\_\_\_

Reaction with HCl: None \_\_\_\_\_ Weak \_\_\_\_\_ Strong \_\_\_\_\_

-----  
**EXCAVATING/AUGERING/DRILLING CONDITIONS:**

Hardness: Very Soft \_\_\_\_\_ Soft \_\_\_\_\_ Hard \_\_\_\_\_ Very Hard \_\_\_\_\_

Penetration Action: Smooth \_\_\_ Mod. Smooth \_\_\_ Mod. Rough \_\_\_ Rough \_\_\_

Penetration Rate: Very Fast \_\_\_ Fast \_\_\_ Slow \_\_\_ Very Slow \_\_\_

PAGE \_\_\_ OF \_\_\_

Figure 11-12.—Field form - soil logging.

## FIELD MANUAL

The specimens for testing are to be samples that represent the entire interval being described (see USBR 7000 and 7010 [1]). The material collected must be split or quartered to obtain the specimen that is to be tested in the laboratory.

Coefficients of uniformity and curvature ( $C_u$  and  $C_c$ ) are to be calculated and reported on the logs for coarse-grained materials containing 12 percent or less fines.

Laboratory gradation percentages and Atterberg limits are to be reported to the nearest whole number.

Procedures for Reporting Laboratory Data in Addition to Visual Classification and Description.—In some instances, gradation analyses and Atterberg limit tests are performed on soil samples in conjunction with preparation of logs of test pits or auger holes. These data should be shown on the logs and clearly identified as laboratory test data.

Specimens for testing are to be from samples that represent the entire interval being described. If this is not possible, the location of the sample should be given as part of the word description. The sample taken should be split or quartered to get the specimen size required for testing (figure 11-5, interval 0.0 to 9.8 feet (ft)).

Laboratory test data are to be presented in a separate paragraph. If the test results indicate a different classification, and therefore different group symbol and/or group name than the visual classification, give the laboratory classification symbol and name in this paragraph (figure 11-6).

## LOGGING SOILS

**Note:** For logs which incorporate the test results, the statement "Classification by laboratory" should be placed in the "Remarks" portion of the log.

Coefficients of uniformity and curvature ( $C_u$  and  $C_c$ ) are to be calculated and reported on the logs for coarse-grained materials containing 12 percent or less fines.

All laboratory gradation percentages and Atterberg limits are to be reported to the nearest whole number.

### Reporting Undisturbed (In-Place) Conditions

List in-place conditions on logs of test pits in a separate paragraph (figure 11-7). Do not give in-place soil conditions (consistency, compactness) on auger hole logs (unless the holes are large enough to inspect). Instead, describe difficulty of augering (figure 11-8). Also describe caving or any other unusual occurrences during drilling of the auger hole.

In-place density tests are often performed in test pits or trenches. When a large quantity of logs are reviewed, density information on the log can save time, even though additional time is required for preparation of the log.

Results of in-place density tests that are performed in test pits or trenches are to be included on the log in the descriptive paragraph on in-place conditions, as illustrated in figure 11-10.

Results of any laboratory compaction tests (Proctor, minimum and maximum density) performed on the material from the in-place density tests or from the pit or trench are to be included on the log.

## FIELD MANUAL

For pipeline investigations, the percent of the maximum dry density or the percent relative density should be in parentheses on the logs (figure 11-10).

Densities are reported to the nearest 0.1 pound per cubic foot ( $\text{lb}/\text{ft}^3$ ) or 1 kilogram per cubic meter ( $\text{kg}/\text{m}^3$ ). Moisture content is reported to the nearest 0.1 percent. Percent of laboratory maximum dry density or relative density is reported to the nearest whole number.

### Geologic Interpretations

Geologic interpretations should be made by or under the supervision of a geologist. Give geologic interpretation in a separate paragraph (figure 11-7). Interpretation should also be included in the narrative section of the materials portion of the design data submittals.

### Description Formats on Test Pit and Auger Hole Logs for Soils with Cobbles and Boulders

If the soil has less than 50 percent cobbles and boulders (by volume), give the group name of the minus 75-mm portion and include cobbles and/or boulders in the group name (figure 11-11). Use two paragraphs to describe soil. Refer to chapter 3 for a more complete discussion of classification and classification group names and symbols.

- Describe the minus 75-mm fraction in the first paragraph. These component percentages are estimated by weight.
- Describe the total sample in a second paragraph. These percentages are estimated by volume. Even if the percentage of cobbles and boulders is determined by measurement, use “approx.” in the word description.

## LOGGING SOILS

If the soil has more than 50 percent cobbles and boulders (by volume), list cobbles and boulders first in the name (figure 11-13). Do not give a group symbol or group name.

- Describe the total sample in the first paragraph. Percentages are estimated by volume.
- Describe the minus 75-mm fraction in a second paragraph. Percentages are estimated by weight.

Angular particles larger than 75 mm are described as cobbles and boulders, not as rock fragments. A description of their shape should be provided in the word description.

### Description of Materials Other than Natural Soils

Materials which are not natural soils are not described or classified in the same manner as natural soils. The section titled "Use of Soil Classification as Secondary Identification Methods for Materials other than Natural Soils", chapter 3, outlines the criteria to be followed and provides example descriptions for test pit and auger hole logs. Refer to appropriate sections in chapter 3 for example format and descriptions. Figures 11-14 through 11-17 show a variety of logs of test pits and auger holes reflecting miscellaneous conditions.

### Format of Word Descriptions for Drill Hole Logs

The descriptions of surficial deposits and soil-like materials in geologic logs of exploration holes should use similar descriptive criteria and format established for test pits and auger holes except as noted in the following paragraphs.

# FIELD MANUAL

7-1336-A (1-66) Bureau of Reclamation		<b>LOG OF TEST PIT OR AUGER HOLE</b>		HOLE NO. _____	
FEATURE _____ PROJECT _____			GROUND ELEVATION _____		
AREA DESIGNATION _____			METHOD OF EXPLORATION _____		
COORDINATES N _____ E _____			LOGGED BY _____		
APPROXIMATE DIMENSIONS _____			DATE(S) LOGGED _____		
DEPTH WATER ENCOUNTERED $\frac{1}{2}$ _____ DATE _____					
CLASSIFICATION GROUP SYMBOL (describe sample taken)	CLASSIFICATION AND DESCRIPTION OF MATERIAL  SEE USBR 8000, 8006	% PLUS 3 in (BY VOLUME)			
		3 - 8 in	8 - 12 in	PLUS 12 in	
Cobbles and Boulders          4.5 ft	<p>0.0 to 4.5 ft COBBLES AND BOULDERS WITH SILTY GRAVEL AND SAND:</p> <p>TOTAL SAMPLE (BY VOLUME): About 35% 3- to 5-inch hard, sub-rounded cobbles; about 30% 5- to 12-inch hard, subangular to subrounded cobbles; about 5% hard, subrounded boulders; remainder minus 3 inch; maximum dimension, 600 mm.</p> <p>MINUS 3-inch FRACTION (BY MASS): About 40% coarse to fine, hard, subrounded gravel; about 30% coarse to fine, hard, sub-rounded sand; about 30% nonplastic fines; no reaction with HCl.</p> <p>IN-PLACE CONDITION: homogeneous, moist, brown</p>	35	30	5	
REMARKS					

$\frac{1}{2}$  Report to nearest 0.1 foot

GPO 849-367

Figure 11-13.—Soil with more than 50 percent cobbles and boulders.



# LOGGING SOILS

P. 1134-A (1-61) Bureau of Reclamation		LOG OF TEST PIT OR AUGER HOLE	HOLE NO. _____	
FEATURE _____ PROJECT _____		GROUND ELEVATION _____		
AREA DESIGNATION _____		METHOD OF EXPLORATION _____		
COORDINATES N _____ E _____		LOGGED BY _____		
APPROXIMATE DIMENSIONS _____		DATE(S) LOGGED _____		
DEPTH WATER ENCOUNTERED 1/ _____ DATE _____				
CLASSIFICATION GROUP SYMBOL <i>(Describe sample system)</i>	CLASSIFICATION AND DESCRIPTION OF MATERIAL  SEE USBR 2006, 2005	S. PLUS 3 IN. 18" VOLUMES		
		3 IN.	6 IN.	12 IN.
CL/CH	0.0 to 2.9 ft LEAN TO FAT CLAY: About 95% fines with medium to high plasticity, high dry strength, medium to high toughness; about 5% fine sand; maximum size, fine sand; dry, reddish-brown; hard to auger; no reaction with HCl.			
2.9 ft				
REMARKS				

1/ Moisture in percent @ 1 foot G-17 (Rev. 1-)

Figure 11-14.—Borderline soils.

# FIELD MANUAL

7-1334-A (1-66) Bureau of Reclamation	LOG OF TEST PIT OR AUGER HOLE		HOLE NO. _____	
FEATURE _____		PROJECT _____		
AREA DESIGNATION _____		GROUND ELEVATION _____		
COORDINATES N _____ E _____		METHOD OF EXPLORATION _____		
APPROXIMATE DIMENSIONS _____		LOGGED BY _____		
DEPTH WATER ENCOUNTERED 1/ _____ DATE _____		DATE(S) LOGGED _____		
CLASSIFICATION GROUP SYMBOL  (describe sample taken)	CLASSIFICATION AND DESCRIPTION OF MATERIAL  SEE USBR 8000, 8005	% PLUS 3 in. (BY VOLUME)		
		3 - 8 in	6 - 12 in	PLUS 12 in
CL  three sack samples      4.2 ft	0.0 to 4.2 ft LEAN CLAY: About 90% fines with medium plasticity, high dry strength, medium toughness; about 10% predominantly fine sand; maximum size, medium sand; strong reaction with HCl.  IN-PLACE CONDITION: Soft, homogeneous, wet, brown.  Three 50-lbm sack samples taken from 12-inch-wide sampling trench for entire interval on north side of test pit. Samples mixed and quartered.			
(SC)g  block sample      9.8 ft	4.2 to 9.8 ft CLAYEY SAND WITH GRAVEL: About 50% coarse to fine, hard, subangular to subrounded sand; about 25% fine, hard, subangular to subrounded gravel; about 25% fines with medium plasticity, high dry strength, medium toughness; maximum size, 20 mm; weak reaction with HCl.  IN-PLACE CONDITION: Firm, homogeneous except for occasional lenses of clean fine sand 1/4 inch to 1 inch thick, moist, reddish-brown.  12- by 12-inch block sample taken at 6.0 to 7.0 ft depth, at center of south side of test pit.			
REMARKS				

1/ Report to nearest 0.1 foot

CPO 848-101

Figure 11-15.—Test pit with samples taken.

# LOGGING SOILS

7-1334 A (1-64) Bureau of Reclamation		LOG OF TEST PIT OR AUGER HOLE		HOLE NO. _____	
FEATURE _____		PROJECT _____		GROUND ELEVATION _____	
AREA DESIGNATION _____		COORDINATES N _____ E _____		METHOD OF EXPLORATION _____	
APPROXIMATE DIMENSIONS _____		DEPTH WATER ENCOUNTERED 1/ _____		LOGGED BY _____	
DATE _____		DATE(S) LOGGED _____			
CLASSIFICATION GROUP SYMBOL <small>(Describe sample taken)</small>	CLASSIFICATION AND DESCRIPTION OF MATERIAL  SEE USBR 8000, 8006	% PLUS 3 in (BY VOLUME)			
		3 - 6 in	6 - 12 in	12 - 18 in	PLUS 18 in
SH          3.1 m	0.0 to 3.1 m SILTY SAND: About 70% coarse to fine, hard, angular sand; about 25% nonplastic fines, rapid dilatancy, no dry strength; about 5% fine, hard, angular gravel; maximum size, 10 mm; moist, brown, faint organic odor; some roots present, easy to auger; no reaction with HCl.				
GC          6.7 m	3.1 to 6.7 m CLAYEY GRAVEL: About 75% coarse to fine, hard, subrounded gravel; about 15% fines with medium plasticity, high dry strength, medium toughness; about 10% coarse, hard, subrounded sand; maximum size, 75 mm; dry, brown; hard to auger; strong reaction with HCl.				
SH/ML          9.7 m	6.7 to 9.7 m SILTY SAND: About 55% medium to fine sand; about 45% nonplastic fines, slow dilatancy; maximum size, medium sand; wet, reddish-brown; easy to auger; no reaction with HCl.				
REMARKS					

1/ Report to nearest 0.1 foot.

GPO 849-284

Figure 11-16.—Disturbed samples.

# FIELD MANUAL

7-1334-A (1-84) Bureau of Reclamation		LOG OF TEST PIT OR AUGER HOLE		HOLE NO. _____		
FEATURE _____ PROJECT _____						
AREA DESIGNATION _____ GROUND ELEVATION _____						
COORDINATES N _____ E _____ METHOD OF EXPLORATION _____						
APPROXIMATE DIMENSIONS _____ LOGGED BY _____						
DEPTH WATER ENCOUNTERED $\frac{1}{2}$ _____ DATE _____ DATE(S) LOGGED _____						
CLASSIFICATION GROUP SYMBOL <small>(describe sample taken)</small>	CLASSIFICATION AND DESCRIPTION OF MATERIAL  SEE USBR 8000, 8006	% PLUS 3 in (BY VOLUME)				
		2 - 6 in	8 - 12 in	PLUS 12 in		
SC         2.7 ft	<p>0.0 to 2.7 ft CLAYEY SAND WITH COBBLES: About 55% coarse to fine, hard, subrounded sand; about 35% fines with medium plasticity, medium toughness; about 10% coarse to fine, hard, subrounded gravel; weak reaction with HCl.</p> <p>TOTAL SAMPLE (BY VOLUME): About 5% 3- to 5-inch hard, subrounded cobbles; remainder minus 3 inch; maximum dimension, 100 mm.</p> <p>IN-PLACE CONDITION: Firm, homogeneous, moist, gray; some mica present</p>	5				
SC         2.7 ft	<p>0.0 to 2.7 ft CLAYEY SAND WITH GRAVEL AND COBBLES: About 45% fine to coarse, hard, subrounded sand; about 35% fines with medium plasticity, medium toughness; about 20% fine to coarse, hard, subrounded gravel; trace of hard, subrounded cobbles; maximum dimension, 150 mm; moist, gray; some mica present; no reaction with HCl.</p>	tr				
REMARKS						

$\frac{1}{2}$  Report to nearest 0.1 foot

SFD 545-361

Figure 11-17.—Two descriptions from the same horizon. (Top) Undisturbed soil containing estimated percent of boulders. (Bottom) Disturbed soil containing trace of cobbles.

## LOGGING SOILS

### Exceptions to Test Pit and Auger Hole Format and Descriptions for Drill Hole Logs

Unlike test pit logs where geologic interpretations may be provided at the bottom of the log form, geologic interpretations are required on drill hole logs. The geologic classification (e.g., Quaternary Alluvium, Quaternary Glacial Outwash, Quaternary Landslide, Tertiary Basin Fill Deposits) should be provided as main headings on the geological drill hole log.

Group names are capitalized in all test pit and auger hole logs. Where capitalization of the group name would conflict with main headings on drill hole logs, capitalize only the first letter of each word of the group name and the group symbol. If the first letter of each word is not capitalized, the group name is considered informal usage only and not a classification.

Classification and word description format for drill hole logs is similar to those used for test pit logs. Also, materials recovered from drill holes are generally considered to represent in-place conditions. These criteria do not apply when samples are not recovered or when poor recovery precludes classification (figure 11-18).

#### Samples Recovered from Wash Borings or as Cuttings

When drill holes are advanced with a rock bit, water jet, or other nonsampling methods, a group symbol and name or classification of the recovered materials should not be assigned, nor should in-place descriptions, such as consistency, be used. However, descriptive criteria, such as particle size, dry strength, and reaction with HCl, should be provided using the same terminology and format used for auger holes.

7-1897 (6-74)  
Bureau of Reclamation

### GEOLOGIC LOG OF DRILL HOLE

SHEET..... OF.....

FEATURE .....		PROJECT .....				STATE .....	
HOLE NO. ....	LOCATION .....	COORDS. N. ....		E. ....	GROUND ELEV. ....	DIP (ANGLE FROM HORIZ.) .....	
BEGUN .....	FINISHED .....	DEPTH OF OVERBURDEN .....		TOTAL DEPTH .....	BEARING .....		
DEPTH AND ELEV. OF WATER LEVEL AND DATE MEASURED .....		LOGGED BY .....				LOG REVIEWED BY .....	

NOTES ON WATER LOSSES AND LEVELS, CASING, CEMENTING, AND OTHER DRILLING CONDITIONS	TYPE AND SIZE OF HOLE	CORE RECOVERY (%)	PERCOLATION TESTS						DEPTH (FEET)	ELEV. (FEET)	DEPTH (FEET)	GEOLOGIC LOG	SAMPLES FOR TESTING	CLASSIFICATION AND PHYSICAL CONDITION
			DEPTH (FEET)		LOSS (G.P.M.)	PRESSURE (P.S.I.)	LENGTH OF TEST (MIN.)	ELEV. (FEET)						
			FROM (F. C.)	TO										
<p>NOTE: Where materials are not recovered from drill hole, but in-place conditions may be determined from other observations, descriptions are permissible in either the right-hand column of the log or as a note in the left-hand column.</p> <p>NOTE: No classification is obtained or wash bored.</p> <p>NOTE: Where poor recovery is obtained do not assign group names. However, provide as much descriptive information as possible.</p>	<p>10</p> <p>20</p> <p>30</p> <p>40</p>	<p>10</p> <p>20</p> <p>30</p> <p>40</p>											<p>0.0-16.0': <b>FILL.</b> Exposure in road cut 15 ft to the west of drill hole is Clayey Gravel (GC) with approx. 75% coarse to fine, hard, angular, metamorphic gravel; 15% fines with medium plasticity, high dry strength, medium toughness; 10% coarse, hard, angular sand; max. size 7mm; strong reaction with HCl. In-place condition is firm, moist, reddish-brown. Material is apparently unzoned miscellaneous fill.</p> <p>0.0-11.7': <b>Rockbitted.</b> Recovered cuttings as angular, metamorphic sand and fine gravel.</p> <p>11.7-16.0': <b>Poor Recovery.</b> Recovered four angular, gravel-size fragments with reddish-brown, sandy clay coatings in upper 3.5'. Fines and sand washed away. Lower 0.8' is lean clay (residual soil). Materials recovered were approx. 85% fines with low to medium plasticity, high dry strength, medium toughness; 15% predominantly fine sand; max. size coarse sand; firm, moist, dark brown, strong reaction with HCl.</p> <p>14.0-39.8': <b>PRECAMBRIAN GRANITE.</b> [Describe as rock unit.]</p>	

Figure 11-18.—Drill hole advanced by tri-cone rock bit.

## LOGGING SOILS

Descriptions should be preceded by “Recovered cuttings as . . .” or “Recovered wash samples as. . .” (figure 11-18, interval 0.0-11.7 ft.

### Poor or Partial Recovery

Where poor or partial recovery precludes accurate classification, a primary classification should not be assigned, but as much descriptive information as possible should be provided. Recovered materials, together with drilling conditions, cuttings, and drilling fluid color or losses, may be used to interpret reasons for losses and types of materials lost. However, an appropriate subheading (i.e., “Poor Recovery”) should be used (figure 11-19, 2.1 to 3.9 ft.

### Materials Other Than Soils and Special Cases

As discussed in chapter 3, “Use of Soil Classification as Secondary Identification Methods for Materials Other Than Natural Soils,” exceptions to the test pit and hole classification and format are also applicable to hole logs. These special cases include processed or manmade materials, shells, partially lithified or poorly cemented materials and decomposed bedrock, and shallow surficial deposits or soils. Other special categories of soil-like materials should be classified by USBR 5000 or USBR 5005[1]. These are soil-like slide-failure zones or planes; shear or fault zones; bedrock units which are recovered as soil-like material or consist of soil-like material; and landslides and talus (figures 11-20, 11-21, and 11-22).

Format and classification for these exceptions are described below.

GEOLOGIC LOG OF DRILL HOLE										SHEET		OF	
FEATURE		LOCATION				PROJECT				STATE			
HOLE NO.		COORD. N.		E.		GROUND ELEV.		ELEVATION FROM WORK		TOTAL DEPTH		BEARING	
SECTION		FINISH		DEPTH OF OVERBURDEN		LOGGED BY		LOG REVIEWED BY					
DEPTH AND ELEV. OF WATER LEVEL AND DATE MEASURED		TYPE AND SIZE OF HOLE		PERCOLATION TESTS		ELEV. OF TEST		DEPTH OF TEST		CLASSIFICATION AND PHYSICAL CONDITION			
NOTES ON WATER LEVELS AND LEVEL, CASING CREWING, CAVING, AND OTHER DRILLING CONDITIONS		RECOVERY		DEPTH (FEET)		LOGS		PERCENT		ELEV. OF TEST			
		(%)		FROM TO		10-P.M. (P.T.)		OF TEST (MIN.)		ELEV. OF TEST (FEET)			
										DEPTH (FEET)			
										GRAPHIC LOG			
										SAMPLES FOR ANALYSIS			
										0.0-1.0': <b>ADULTS AND BIRD NESTS.</b>			
										1.0-3.0': <b>PERVIOUS SPERMATOPHYTES 3.</b>			
										0.0-2.1': <b>Rockblitted.</b> Recovered cut-			
										tings as fine to coarse, angular			
										sand and fine gravel-size, angular,			
										meta-sedimentary rock fragments.			
										2.1-3.0': <b>Poor Recovery.</b> Recovered			
										as gravel-size, hard, angular,			
										meta-sedimentary and granitic rock			
										fragments and gravel, mostly			
										30-60m, max. size 7mm; and approx.			
										5% soft, wet, sandy clay. No			
										reaction to HCl. Most of fines			
										washed away during drilling.			
										3.9-15.4': <b>PERVIOUS SPERMATOPHYTES 1.</b>			
										3.9-12.3': <b>Lean Clay w/trace of</b>			
										Cobbles (CL). Approx. 60% fines			
										with medium plasticity, high dry			
										strength, medium toughness; approx.			
										20% fine to coarse subangular sand;			
										trace of hard, subrounded cobbles;			
										max. size 10mm. Fine homogeneous,			
										sandy, light brown. Weak reaction			
										with HCl.			
										10.0-12.7': <b>Poor Recovery.</b> Fines			
										washed away, barrel blocked.			
										12.7-15.4': <b>Sandy Clay (CL).</b> Approx.			
										60% fines with medium plasticity.			
										(Continue with description.)			
										15.4-21.7': <b>PERVIOUS SPERMATOPHYTES 2.</b>			
										15.4-21.7': <b>Sandstone.</b> Gray, fine-			
										grained, etc. (Continue description.)			

Figure 11-19.—Log showing poor recovery.



GEOLOGIC LOG OF DRILL HOLE

FEATURE		PROJECT		STATE								
LOCATION		COORDS. N. E		GROUND ELEV.								
DIP (ANGLE FROM HORIZ)		TOTAL DEPTH		BEARING								
DEPTH AND ELEV. OF WATER LEVEL AND DATE MEASURED		LOGGED BY		LOG REVIEWED BY								
NOTES ON WATER LOSSES AND LEVELS, CASING, CEMENTING, CAVING, AND OTHER DRILLING CONDITIONS	TYPE AND SIZE OF HOLE	PERCOLATION TESTS					ELEVATION (FEET)	DEPTH (FEET)	GENERIC LOG	SAMPLES FOR TESTING	CLASSIFICATION AND PHYSICAL CONDITION	
		RECOVERY (%)	DEPTH (FEET)		LOSS (G.P.M.)	PRESSURE (P.S.I.)						WELL OPENING (INCHES)
			FROM (IN. CAL.)	TO								
										<p>0.0-1.0': <u>SLOPE WASH (Qsu)</u>. Red-brown, moist, firm, lean to fat clay (CL, CH) (upper 0.2' is dark brown topsoil). Roots extend to 0.8'.</p> <p>1.0-38.2': <u>QUATERNARY LANDSLIDE (Qla)</u>. Poor to moderate recovery. Composed of randomly oriented, moderately weathered, hard, angular hornblende schist blocks and fragments, in an estimated 5-20% matrix of red-brown lean clay. Blocks and fragments recovered in core lengths to 3.2', mostly 0.5' - to 1.2' lengths.</p> <p>0.2- to 1.4'- <u>Clay Matrix Lean Clay (CL)</u> Where recovered, matrix consists of approx. 90% fines with medium plasticity, high dry strength, medium toughness, approx. 10% fine to coarse, hard, angular to subrounded sand. Matrix is firm, moist, light brown. No reaction to HCl.</p> <p>36.0-38.2': <u>Slide Plane Lean Clay (CL)</u> 2.2' thick, upper contact dips 30°, dip of lower contact unknown. Composed of approx. 90% fines with medium to high plasticity, high dry strength, medium toughness, moist, firm, red-brown and tan; no reaction with HCl; 10% subangular to wedge-shaped, hard, 0.01 to 0.04' thick, hornblende schist fragments. Fragments break with slight finger pres.</p>		

LOGGING SOILS

Figure 11-20.—Log of landslide material (a).

7-1137 (8-74)  
Boring and Paving

### GEOLOGIC LOG OF DRILL HOLE

SHEET ..... OF .....

FEATURE .....		PROJECT .....				STATE .....	
HOLE NO. ....	LOCATION .....	COORDS. N. .... E. ....		GROUND ELEV. ....	DIP (ANGLE FROM HORIZ.) .....		
BEGUN .....	FINISHED .....	DEPTH OF OVERBURDEN .....		TOTAL DEPTH .....	BEARING .....		
DEPTH AND ELEV. OF WATER LEVEL AND DATE MEASURED .....		LOGGED BY .....				LOG REVIEWED BY .....	

NOTES ON WATER LOSSES AND LEVELS, CASING, CEMENTING, CAVING, AND OTHER DRILLING CONDITIONS	TYPE AND SIZE OF MOLE	RECOVERY (%)	PERCOLATION TESTS				DEPTH (FEET)	ELEV. FROM (FEET)	DEPTH (FEET)	GRAPHIC LOG	SAMPLES FOR TESTING	CLASSIFICATION AND PHYSICAL CONDITION	
			DEPTH (FEET)		LOSS (G.P.M.)	PRESSURE (P.S.I.)							LENGTH OF TEST (MIN.)
			FROM (P.C.)	TO									
												0.0-2.0': <u>QUATERNARY COLLUVIUM (Qc)</u> . Residual soil and slope wash. Consists of approx. 55% red-brown fat clay, 20% fine sand and 25% intensely weathered, 0.1 to 0.4' thick soft, angular, fine gravel sandstone fragments.	
												2.0-17.3': <u>QUATERNARY LANDSLIDE DEBRIS (Qlb)</u> . Moderate recovery due to Gravel-, cobble-, and boulder-size fragments.	
												2.0-13.6': <u>Sandy Clay with Cobbles (Qc/c)</u> . [Describe as per criteria for test pits and auger holes.]	
												13.6-16.7': <u>Clayey Gravel with Cobbles and Boulders (Qc/cb)</u> . [Describe as per criteria for test pits and auger holes.]	
												16.7-17.3': <u>Slide Plane, Gravely clay (Qc)</u> . 0.6' thick, dips 30°, parallel to bedding. Consists of approx. 60% fines with medium plasticity, high dry strength, medium toughness, moist, firm, red-brown; 25% mostly 0.02 to 0.08" thick platy to angular, intensely weathered, meta-silt fragments, max. size 0.2' and 15% fine, angular sand. Fragments break with slight manual pressure.	
												17.1-17.3': Dark brown, highly slickensided surfaces, slickensides parallel to contact.	

(sheet 1 of 2)

Figure 11-21.—Log of landslide material (b).

**GEOLOGIC LOG OF DRILL HOLE**

FEATURE.....		PROJECT.....		STATE.....	
HOLE NO.....	LOCATION.....	GROUND ELEV.....		DIP (ANGLE FROM HORIZ).....	
BEGUN.....	COORDS. N..... E.....	DEPTH OF OVERBURDEN.....		TOTAL DEPTH.....	BEARING.....
DEPTH AND ELEV. OF WATER LEVEL AND DATE MEASURED.....		LOGGED BY.....		LOG REVIEWED BY.....	

NOTES ON WATER LOSSES AND LEVELS, CASING, CEMENTING, CAVING, AND OTHER DRILLING CONDITIONS	TYPE AND SIZE OF MOLE	PERCENT RECOVERY (%)	PERCOLATION TESTS					ELEVATION (FEET)	DEPTH (FEET)	GALVANIC LOG	SAMPLES FOR TESTING	CLASSIFICATION AND PHYSICAL CONDITION
			DEPTH (FEET)		LOSS (G.P.M.)	PRESSURE (P.S.I.)	US MESH (MIN.)					
			FROM (IP, CL, W, CA)	TO								
												17.3-152.6': <b>CRETACEOUS PANOCHE GROUP.</b> 17.3-67.9': Sandstone. Fine to medium grained, mostly subangular grains of quartz with trace of mica. Thinly bedded; bedding mostly 0.1 to 0.3'; dips 30-35°. <u>Intensely weathered</u> , body of rock stained light brown, locally light gray. Core can be gouged 1/16" deep with moderate knife pressure, breaks across bedding and grains with light manual pressure. <u>Moderately Fractured</u> (80% bedding joints, 20% norm jnts) except as noted below. Core recovered in lengths to 1.1', mostly 0.5 to 0.9'. Two joint sets noted: (1) bedding joints dip 30 to 35°; moderately spaced, mostly 0.4 to 0.9'; surfaces smooth to slightly rough, about 40% are open and with 0.01 to 0.03' thick red-brown; fat clay fillings; joint surfaces are weathered and easily gouged with moderate knife pressure. (2) dips 60 to 75°, normal to bedding; widely spaced, mostly 1.0-1.5'; joint surfaces smooth, filled with 0.01" to 0.06' red-brown, fat clay. Sandstone can be disaggregated by hand to "clayey sand (SC)." (Continue with description of rock units.)

(sheet 2 of 2)

LOGGING SOILS

Figure 11-22.—Log of bedrock.

## FIELD MANUAL

Processed or Manmade Materials.—Surficial deposits such as tailings, crushed rock, shells, or slag are assigned a genetic name such as filter, bedding, drain material, shells, tailings, or road base, and a classification group name and symbol are assigned in quotation marks, for example: Filter material, “poorly graded sand (SP-SM).” Soil descriptors are then used to describe the materials.

Where drill holes penetrate embankment materials, main headings on the drill hole logs should be a classification of the type of embankment, such as “Zone 3 Miscellaneous Embankment.” The materials recovered in each interval are classified, and group names and symbols are provided as subheadings. See 1.0- to 3.9-ft and 3.9- to 15.4-ft intervals shown in figure 11-19.

Partially Lithified or Poorly Cemented Materials and Decomposed Rock.—Descriptions of partially lithified or poorly cemented materials such as siltstone, claystone, sandstone, and shale or decomposed rock which are broken down during drilling or field classification testing should be classified by an appropriate rock unit name or by geologic formation name, if known, of the in-place materials. The materials are then described using descriptors for rock (chapter 4). A soil classification for the broken down materials should be reported in quotation marks on the drill logs and all figures, tables, drawings, or narrative descriptions. The disaggregating mechanism (e.g., drilling or testing) should be specified (figure 11-22, interval 17.3 to 67.9 ft).

Shallow Surficial Deposits.—Surficial deposits such as drill pad or dozer trench fill for drill setups, shallow slope wash, or topsoil materials which will not be used in, or influence, design or construction may be classified by genetic classification (e.g., “fill,” “slopewash,” or “topsoil”). Complete classification descriptions are not required on drill hole logs; however, a classification name and/or

## LOGGING SOILS

symbol may be assigned and is often desirable. Although a complete description is not required on each log, an adequate description of these materials should be provided in a general legend or explanation drawing and in the narrative of the report, if not completely described in drill hole logs.

Slide Failure Zones or Planes, Shear or Fault Zones, and Interbeds Recovered as Soil-like Materials.—These features should be described using geologic names as well as behavior and soil classifications.

Landslides and Talus.—Surficial deposits such as landslides and talus should be assigned their genetic geologic name in the main headings of the drill hole log. Landslide debris composed primarily of soils is classified as landslides in the main heading. Soil-like materials should be classified and group names and symbols provided in the headings. The materials are then described using the descriptive criteria for drill hole logs. Where materials are predominantly rock fragments such as talus and block slides, the materials should be logged similar to the method used in figure 11-22.

### Equipment Necessary for Preparing the Field Log

The following is a list of equipment for field testing and describing materials.

Required equipment:

- Small supply of water (squirt bottle)—for performing field tests
- Pocket knife or small spatula
- Materials for taking or preserving samples—sacks, jars, labels, cloth, wax, heater, etc.

## FIELD MANUAL

- Hammer—for hardness descriptors
- Tape measure and/or rule (engineer's scale and metric scale)
- Petrie dish for washing specimens
- Small bottle of dilute hydrochloric acid [one part HCl (10 N) to three parts distilled water. When preparing the dilute HCl solution, slowly add acid into the water following necessary safety precautions. Handle with caution and store safely. If solution comes in contact with skin, rinse thoroughly with water.]
- Rags for cleaning hands
- Log forms

### Optional apparatus:

- Small test tube and stopper or jar with lid
- Plastic bags for “calibration samples”
- Hand lens
- Color identification charts
- Paint brush and/or scrub brush and water for cleaning samples
- Marking pens
- Protractor
- Drillers' reports for drill holes
- Comparison samples (in jars): fine gravel—3/4 inch to No. 4 sieve; medium sand—No. 4 to No. 10 sieve; and coarse sand—No. 10 to No. 40 sieve
- Small No. 4 and 200 sieves

## LOGGING SOILS

### Example Descriptions and Format

The examples which follow illustrate the preferred format, description, and organization, and some of the more significant exceptions to typical standards.

#### Laboratory Classifications in Addition to Visual Classifications

In some instances, laboratory classifications may be determined in addition to the field visual classification. This may be done to confirm the visual classification, particularly when starting work in a new location or because the classification may be critical.

The laboratory data used must be reported in a separate paragraph at the end of the work description, as shown in the examples in figure 11-23. If the laboratory classification is different from the visual classification, as in the upper example, give the group symbol in the left-hand column and the group name in the paragraph on the laboratory data.

**DO NOT CHANGE THE VISUAL CLASSIFICATION OR DESCRIPTION.** The visual classification is based on a widely observed area in the excavation, whereas the laboratory classification is based on a sample of the material.

If the visual classification was the best judgment of an experienced classifier, both are correct in what they represent.

# FIELD MANUAL

Page 1 of 3

7 1330-A (11-80) Bureau of Reclamation		LOG OF TEST PIT OR AUGER HOLE	HOLE NO. <u>TP-1-TTDL</u>				
FEATURE _____ AREA DESIGNATION <u>Sta. 191+74 on Centerline</u> COORDINATES N <u>438,961</u> E <u>766,219</u> APPROXIMATE DIMENSIONS <u>16'x4'x6'</u> DEPTH WATER ENCOUNTERED <u>0</u> See DATE _____		PROJECT _____ GROUND ELEVATION <u>2770.7</u> METHOD OF EXPLORATION <u>MF-80 Backhoe</u> LOGGED BY _____ DATE(S) LOGGED <u>8/6/87</u>					
Remarks							
CLASSIFICATION GROUP SYMBOL (describe sample taken)	CLASSIFICATION AND DESCRIPTION OF MATERIAL  SEE USBR 5000.5005				% PLUS 3 in (BY VOLUME)		
		3	6	PLUS	3	6	12
		in	in	in	in	in	in
(SC)g two 60-lbm sacks          2.0 feet	0.0 to 2.0 ft. CLAYEY SAND WITH GRAVEL AND TRACE OF COBBLES: About 45% coarse to fine, angular to subangular sand; about 40% coarse to fine, angular to subangular, brittle to hard gravel with weak surface coating; about 15% fines with medium to hard plasticity, no dilatancy, medium toughness, medium to high dry strength; max. size, 250 mm; dry, brown; no reaction with HCl.  IN-PLACE CONDITION: Dense, homogeneous, root holes, weak cementation, moist to wet.  LAB TEST DATA: Two sack samples taken from 2-ft-wide swath at 1.5 ft depth across trench. Material mixed and quartered to get test sample. 35% sand, 51% gravel, 14% fines, LL=53, PI=34. Max. unit weight, opt.: 112.3 lb/ft <sup>3</sup> , 15.6%. Laboratory Classification is Clayey Gravel with Sand (GC)s. (Nondispersive).  GEOLOGIC INTERPRETATION: Quaternary Slopewash (Qsw)				T	T	0
(GC)sc two 60-lbm sacks	2.0 to 5.8 ft. CLAYEY GRAVEL WITH SAND AND COBBLES: About 45% coarse to fine, angular to subangular, hard gravel with weak surface coating; about 40% coarse to fine, angular to subangular sand; about 15% fines with medium to high plasticity, slow dilatancy, medium toughness, medium dry strength; weak reaction with HCl.  TOTAL SAMPLE (BY VOLUME): About 5% 75 to 125 mm, brittle to hard, angular to subangular cobbles, and boulders; remainder minus 75 mm; max. dimension 550 mm.  IN-PLACE CONDITION: Dense, heterogeneous, sand and fines, weakly cemented, dry, brown.  LAB TEST DATA: Two 60-lbm sack samples obtained from backhoe bucket from depths of 4.5 to 5.5 ft on northeast side of trench. 43% gravel, 35% sand, 22% fines; LL=50, PI=31. Max. unit weight, opt.: 118.6 lb/ft <sup>3</sup> , 13.3%. (Nondispersive).				5	T	T
REMARKS Moderate ground cover of sagebrush. Maximum size boulder taken from excavation was 550x325x200 mm. Stopped test pit at 6.0 feet unable to excavate further with backhoe. Water encountered only in upper 2.0 ft due to rain from previous three days.							

610-BAL-780

Figure 11-23.—Geologic interpretation in test pit (sheet 1).



## **LOGGING SOILS**

### **Word Descriptions for Various Soil Classifications**

**Figures 11-6 to 11-17 illustrate some typical word descriptions based on the soil classifications.**

**Logs are generally typed and single spaced. The examples in this manual are presented double spaced for legibility.**

#### **Samples Taken**

**In addition to the brief description of the samples taken under the “classification group symbol” column, a more complete description of any samples taken from each depth interval is included in the word descriptions. The description should include the size of the sample, the location represented by the sample, and how the sample was obtained (e.g., quartering and splitting).**

**Examples of how to report the sample information for a pit or trench are shown in figures 11-24 through 11-33.**

**Some examples use the abbreviated method of indicating the group name with the group symbol. This abbreviated method is described in appendix X5 in USBR 5000, “Determining Unified Soil Classification (Laboratory Method)” [1] and chapter 3.**

#### **Reporting Laboratory Data**

##### **Classifications Based on Laboratory Data**

**If the soil classification reported on the logs is based on laboratory data and not a visual classification, this should be clearly and distinctly reflected on the log.**

# FIELD MANUAL

Page 2 of 3

7-113a-A (1-76) Bureau of Reclamation	<b>LOG OF TEST PIT OR AUGER HOLE</b>	HOLE NO. <u>TP-1-TTDL</u>
FEATURE _____ PROJECT _____ AREA DESIGNATION <u>Sta. 191+74 on Centerline</u> GROUND ELEVATION <u>2770.7</u> COORDINATES N <u>438,961</u> E <u>766,219</u> METHOD OF EXPLOSION <u>MF-80 Backhoe</u> APPROXIMATE DIMENSIONS <u>16' x 4' x 6'</u> LOGGED BY _____ DEPTH WATER ENCOUNTERED <u>1/</u> See _____ DATE _____ DATE(S) LOGGED <u>8/6/87</u> Remarks _____		
CLASSIFICATION GROUP SYMBOL (describe sample taken)	CLASSIFICATION AND DESCRIPTION OF MATERIAL  SEE USBR 5000, 5005	% PLUS 3 IF (BY VOLUME)  3 5. PLUS 5 12 12 in in in
5.8 feet	GEOLOGIC INTERPRETATION: Quaternary Slopewash (Qsw)	
6.0 feet	5.8 to 6.0 ft. Andesite: Gray; porphyritic; phenocrysts consist of white plagioclase laths to 1 cm in length in an aphanitic groundmass; non-porous; weak to no reaction with HCl. See "Geologic Profile on Test Pit No. TP-1-TTDL" for detailed hardness, weathering, and fracture density descriptions. No sample taken.  GEOLOGIC INTERPRETATION: Tertiary Shorts Ranch Andesite (Tsa)	
REMARKS		

1/ Report to nearest 0.1 foot

GSC 84-1

Figure 11-24.—Geologic interpretation in test pit (sheet 2).

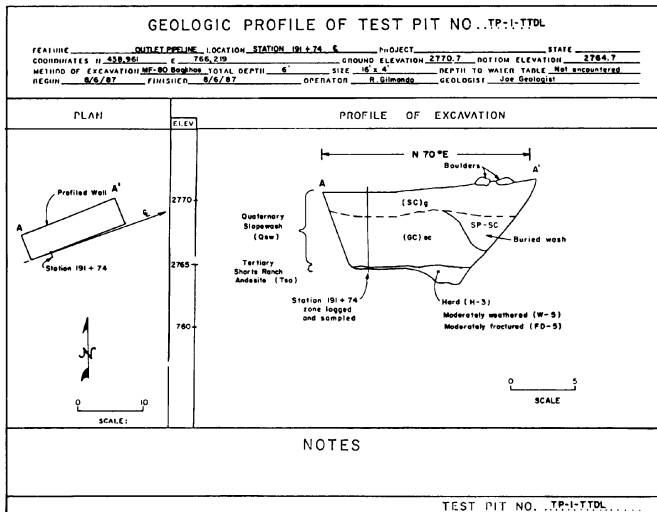


Figure 11-25.—Geologic interpretation in test pit using a geologic profile (1).

# FIELD MANUAL

Page 1 of 3

1336-A (1 Rev) Bureau of Reclamation		LOG OF TEST PIT OR AUGER HOLE	HOLE NO. <u>TP-2-TTDL</u>		
FEATURE		PROJECT _____			
AREA DESIGNATION <u>Sta. 196+01 on Centerline</u>		GROUND ELEVATION <u>2766.8</u>			
COORDINATES N <u>439.095</u> E <u>766.624</u>		METHOD OF EXPLORATION <u>MF-BQ Backhoe</u>			
APPROXIMATE DIMENSIONS <u>17'x4'x7.5'</u>		LOGGED BY _____			
DEPTH WATER ENCOUNTERED <input type="checkbox"/> Not Encountered		DATE(S) LOGGED <u>8/6/87</u>			
CLASSIFICATION GROUP SYMBOL (describe sample taken)	CLASSIFICATION AND DESCRIPTION OF MATERIAL  SEE USBR 8000.8005	% PLUS 3 in (BY VOLUME)			
		3 - 6 in	6 - 12 in	PLUS 12 in	
<p>(SC)g one 45-lbm sacks</p> <p>0.5 feet</p>	<p>0.0 to 0.5 ft. CLAYEY SAND WITH GRAVEL AND TRACE OF COBBLES: About 50% coarse to fine, angular to subangular sand; about 35% coarse to fine, angular to subangular, brittle to hard gravel with weak surface coating; 15% fines with medium plasticity, slow to no dilatancy, medium toughness, medium dry strength; max. size 100 mm; strong reaction with HCl.</p> <p>IN-PLACE CONDITION: Loose, homogeneous, root holes, weak cementation, dry, brown.</p> <p>LAB TEST DATA: 41% sand, 35% gravel, 24% fines, LL=38, PI=16. Lab max. density, opt.: 116.8 lbf/ft<sup>3</sup>, 12.7%. (Nondispersive).</p> <p>GEOLOGIC INTERPRETATION: Quaternary Slopewash (Qsw)</p>	T	0	0	
<p>(GF-GC)sc (Lab Classif.)</p> <p>Andesite (Tsa) two 60-lbm sacks</p>	<p>0.5 to 7.5 ft. Andesite; Dry gray; porphyritic, intensely to moderately weathered; non-porous; weak reaction with HCl on body of rock, strong reaction with carbonate coatings on fracture surfaces. See "Geologic Profile of Test Pit No. TP-2-TTDL" for more detailed hardness, weathering, fracture density, and joint descriptions. Very difficult to excavate below 6.5 feet. Excavated materials breaks down as follows:</p> <p>POORLY GRADED GRAVEL WITH SILT, SAND AND COBBLES: About 60% coarse to fine, angular to subangular, brittle to hard gravel with weak surface coating; about 30% coarse to medium, angular to subangular sand; about 10% fines with low plasticity, slow to rapid dilatancy, low toughness, low dry strength; strong reaction with HCl.</p> <p>TOTAL SAMPLE (BY VOLUME): About 40% 75 to 125 mm brittle to hard, angular to subangular cobbles; trace of plus 125 mm brittle to hard, angular to subangular cobbles; remainder minus 75 mm; max. dimension 250 mm.</p>	40	T	0	
<p>REMARKS Considerable ground cover of mesquite and paloverde trees, greasewood bushes and cacti. Maximum size cobble taken from excavation was 250x250x200 mm. Stopped test pit at 7.5 feet, unable to excavate further with backhoe.</p>					

Figure 11-26.—Geologic interpretation in test pit (sheet 3).

# LOGGING SOILS

Page 1 of 2

9 133a A (1-86) Bureau of Reclamation		LOG OF TEST PIT OR AUGER HOLE	HOLE NO. <u>TP-4-TTDL</u>		
FEATURE _____		PROJECT _____		GROUND ELEVATION <u>2722.6</u>	
AREA DESIGNATION <u>Sta. 20+27 on Centerline</u>		METHOD OF EXPLORATION <u>MF-80 Backhoe</u>		LOGGED BY _____	
COORDINATES N <u>439,409</u> E <u>767,405</u>		APPROXIMATE DIMENSIONS <u>17'x4'x10'</u>		DATE(S) LOGGED <u>8/7/87</u>	
DEPTH WATER ENCOUNTERED <u>1/ Not</u> DATE _____		Encountered			
CLASSIFICATION GROUP SYMBOL (describe sample taken)	CLASSIFICATION AND DESCRIPTION OF MATERIAL  SEE USBR 5000, 5005	% PLUS 3 in. (BY VOLUME)			
		3 in.	6 in.	PLUS 12 in.	
SP-SM           two 60-lb sacks	0.0 to 2.0 ft. POORLY GRADED SAND WITH SILT, GRAVEL AND COBBLES: About 55% coarse to fine, angular to subangular sand; about 35% coarse to fine, angular to subangular, brittle to hard gravel with moderate surface coating; about 10% fines with low plasticity, rapid dilatancy, low toughness, low dry strength; strong reaction with HCl.  TOTAL SAMPLE (BY VOLUME): About 5% 75 to 125 mm, brittle to hard, angular to subangular cobbles; trace of plus 125 mm brittle to hard, angular to subangular cobbles; remainder minus 75 mm; max. dimension, 250 mm.  LAB TEST DATA: Sack samples taken from spoil pile. 46% gravel, 44% sand, 10% fines; LL=30, PI=10, Cu=88.5, Cc=1.8. Maximum and Minimum Relative Density: 127.3 lbf/ft <sup>3</sup> , 99.2 lbf/ft <sup>3</sup> ; Lab max. density, opt.: 117.4 lbf/ft <sup>3</sup> , 13.0%. Laboratory Classification is Well Graded Gravel With Clay and Sand (GW-GC)s. (Nondispersive).  IN-PLACE CONDITION: Loose, homogeneous, root holes, moderate cementation, dry, brown.  GEOLOGIC INTERPRETATION: Quaternary Slopewash (Qsw)	5	T	0	
2.0 feet					
(SM)gc  Andesite (Tsa) two 45-lb sacks	2.0 to 10.0 ft. SILTY SAND WITH GRAVEL WITH TRACE OF COBBLES: About 60% coarse to fine, angular to subangular sand; about 25% coarse to fine, angular to subangular, brittle to hard gravel with moderate surface coating; about 15% fines with low plasticity, rapid dilatancy, low toughness, low dry strength; max. dimension, 250 mm; strong reaction with HCl.  LAB TEST DATA: Two sack samples taken from backhoe bucket at 7.0 to 7.5 depth. 54% sand, 29% gravel, 17% fines; LL=34, PI=8. Lab max. density, opt.: 112.2 lbf/ft <sup>3</sup> , 15.1%. (Nondispersive).	T	T	0	
REMARKS Moderate ground cover of mesquite and paloverde trees, greasewood bushes and maximum size cobble taken from excavation was 400x250x250 mm. Stopped test pit at 10.0 feet, unable to excavate further with backhoe.					

1/ Report to nearest 0.1 foot

GFO 849-1-1

Figure 11-27.—Geologic interpretation in test pit (sheet 4).

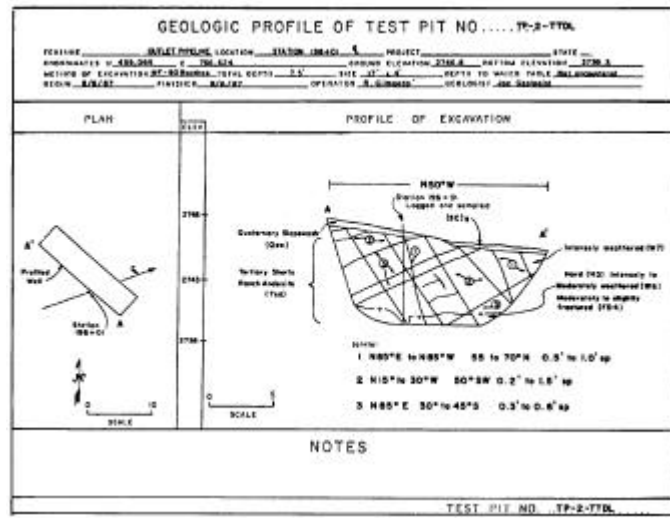


Figure 11-28.—Geologic interpretation in test pit using a geologic profile (2).

# LOGGING SOILS

7 1336 A (1 86) Bureau of Reclamation	<b>LOG OF TEST PIT OR AUGER HOLE</b>	HOLE NO. <u>TP-2-TIDL</u>									
FEATURE _____ PROJECT _____ AREA DESIGNATION <u>Sta. 196+01 on Centerline</u> GROUND ELEVATION <u>2746.8</u> COORDINATES N <u>439.095</u> E <u>766.624</u> METHOD OF EXPLORATION <u>MF-80 Backhoe</u> APPROXIMATE DIMENSIONS <u>17'x4'x7.5'</u> LOGGED BY _____ DEPTH WATER ENCOUNTERED <u>Not</u> DATE _____ DATE(S) LOGGED <u>8/6/87</u> <u>Encountered</u>											
CLASSIFICATION GROUP SYMBOL (describe sample taken)	CLASSIFICATION AND DESCRIPTION OF MATERIAL  SEE USBR 5000, 5005	% PLUS 3 in. (BY VOLUME) <table style="margin: auto;"> <tr> <td style="border: 1px solid black;">3</td> <td style="border: 1px solid black;">5</td> <td style="border: 1px solid black;">PLUS</td> </tr> <tr> <td style="border: 1px solid black;">in</td> <td style="border: 1px solid black;">12</td> <td style="border: 1px solid black;">12</td> </tr> <tr> <td style="border: 1px solid black;"></td> <td style="border: 1px solid black;">in</td> <td style="border: 1px solid black;">in</td> </tr> </table>	3	5	PLUS	in	12	12		in	in
3	5	PLUS									
in	12	12									
	in	in									
7.5 feet	LAB TEST DATA: 68% gravel, 25% sand, 7% fines; LL=36, PI=12; Cu=53.1, Cc=4.3. Maximum and minimum relative density; 127.9 lbf/ft <sup>3</sup> ; 96.8 lbf/ft <sup>3</sup> ; proctor max. density, opt.: 117.9 lbf/ft <sup>3</sup> , 13.6%. Laboratory Classification is Poorly Graded Gravel with Clay and Sand (GP-GC)s. (Nondispersive).  GEOLOGIC INTERPRETATION: Tertiary Shorts Ranch Andesite (Tsa)										
REMARKS											

1/ Report to nearest 0.1 foot

GFC 849-211

Figure 11-29.—Geologic interpretation in test pit (sheet 5).

# FIELD MANUAL

7-1336-A (1-84) Bureau of Reclamation	<b>LOG OF TEST PIT OR AUGER HOLE</b>	HOLE NO. <u>TP-4-TTDL</u>
FEATURE _____ PROJECT _____ AREA DESIGNATION <u>Sta. 203+27 on Centerline</u> GROUND ELEVATION <u>2722.6</u> COORDINATES N <u>439,409</u> E <u>767,405</u> METHOD OF EXPLORATION <u>MF-80 Backhoe</u> APPROXIMATE DIMENSIONS <u>17'x4'x10'</u> LOGGED BY _____ DEPTH WATER ENCOUNTERED <u>1/ Not</u> DATE _____ DATE(S) LOGGED <u>8/7/87</u> <u>Encountered</u>		
CLASSIFICATION GROUP SYMBOL (describe sample taken)	CLASSIFICATION AND DESCRIPTION OF MATERIAL  SEE USBR 5000, 5005	% PLUS 3 in (BY VOLUME) 3- 5- 12- 12- in in in in
10.0 feet	Excavated material in place is: Andesite; Dry; gray; porphyritic; irregular weathering profile, 2.0 to 7.5 ft. decomposed, (W9), very soft (H7), some structure visible, carbonate cementation throughout; 7.5 to 9.8 ft. intensely weathered, (W7), soft (H6), intensely fractured (FD7), carbonate coatings on joint surfaces; 9.8 to 10.0 ft. intensely to moderately weathered (W6), moderately hard (H4), intensely fractured (FD7). Hardness increases with depth.  GEOLOGIC INTERPRETATION: Tertiary Shorts Ranch Andesite (Tsa)	
REMARKS		

1/ Report to nearest 0.1 foot

GPO 829-121

Figure 11-30.—Geologic interpretation in test pit (sheet 6).



# LOGGING SOILS

7 1334 A (1 Rev) Bureau of Reclamation	<b>LOG OF TEST PIT OR AUGER HOLE</b>	HOLE NO. <u>TP-FWT-101</u>										
FEATURE _____ PROJECT <u>Central Utah</u> AREA DESIGNATION _____ GROUND ELEVATION _____ COORDINATES N _____ E _____ METHOD OF EXPLORATION <u>John Deere 710B Backhoe</u> APPROXIMATE DIMENSIONS <u>5' x 20' x 15'</u> LOGGED BY _____ DEPTH WATER ENCOUNTERED <u>1/ 13.0</u> DATE _____ DATE(S) LOGGED <u>5/11/87</u>												
CLASSIFICATION GROUP SYMBOL (describe sample taken)	CLASSIFICATION AND DESCRIPTION OF MATERIAL  SEE USBR 5000, 5005	% PLUS 3 in (BY VOLUME) <table style="margin: auto; border-collapse: collapse;"> <tr> <td style="border: 1px solid black; padding: 2px;">3</td> <td style="border: 1px solid black; padding: 2px;">5</td> <td style="border: 1px solid black; padding: 2px;">12</td> <td style="border: 1px solid black; padding: 2px;">PLUS</td> <td style="border: 1px solid black; padding: 2px;">12</td> </tr> <tr> <td style="border: 1px solid black; padding: 2px;">in</td> <td style="border: 1px solid black; padding: 2px;">in</td> <td style="border: 1px solid black; padding: 2px;">in</td> <td style="border: 1px solid black; padding: 2px;"></td> <td style="border: 1px solid black; padding: 2px;">in</td> </tr> </table>	3	5	12	PLUS	12	in	in	in		in
3	5	12	PLUS	12								
in	in	in		in								
MH (lab. classif.)  one 45-lb sack  1.5 feet	0.0 to 1.5 ft. ELASTIC SILT: Sack sample (No. 1) from swath along entire trench at a depth of 1.0 ft had 77% fines; 23% predominantly fine sand; maximum size, medium sand; no reaction with HCl; LL=52, PI=21, Minus #4 SpG. = 2.63.  IN-PLACE CONDITION: Homogeneous, moist, soft, dark brown; some roots present.  GEOLOGIC INTERPRETATION: Road fill.											
ML (lab. classif.) INTENSELY WEATHERED SHALE  5.0 feet	1.5 to 5.0 ft. SANDY SILT WITH GRAVEL: Recovered predominantly as sandy silt with decomposed to intensely weathered elongated fragments of shale ranging in size from fine sand to fine gravel. Some lenses and pockets of sandy silt are also present. Gravel fragments break easily with slight finger pressure. Sack sample (No. 2) taken from 18-in-wide sample trench from 3.5 to 4.5 ft depth on east wall (see sketch). Sample contained 52% fines; 35% predominantly fine sand; 13% gravel; maximum size 18 mm; moderate reaction with HCl; LL=39, PI=12, Minus #4 SpG. = 2.70. Laboratory Classification is Sandy Silt (ML).  IN-PLACE CONDITION: Loose, slightly moist easily excavated, some roots down to 4.0 ft, no cementation between fragments, bedding faintly visible below 4.0 ft, vertical stringers of silty sand fill open joints, gray and green, rapid sloughing of trench walls.  GEOLOGIC INTERPRETATION: Tertiary Green River Formation (Tgr)											
GM (lab. classif.) MODERATELY WEATHERED SHALE	5.0 to 10.5 ft. MODERATELY WEATHERED SHALE: Recovered predominantly as moderately weathered gravel to boulder-size angular fragments of shale. Material in trench wall (see sketch) is mostly intensely fractured shale with silt-filled joints. Maximum dimension 18 inches. Many of the larger											
REMARKS Cover; Sagebrush, grass and weeds. Stopped excavation at 14.0 ft. due to backhoe refusal. Unable to penetrate. Excavated near small stream. Geologic descriptions by Joe Geologist.												

1/ Report to nearest 0.1 foot

GPO 849-27-1

Figure 11-31.—Geologic interpretation in test pit (sheet 7).

# FIELD MANUAL

7 133a A (1-80) Bureau of Reclamation		LOG OF TEST PIT OR AUGER HOLE	HOLE NO. <u>TP-FWT-101</u>	
FEATURE _____		PROJECT <u>Central Utah</u>		
AREA DESIGNATION _____		GROUND ELEVATION _____		
COORDINATES N _____ E _____		METHOD OF EXPLORATION <u>John Deere 710B Backhoe</u>		
APPROXIMATE DIMENSIONS <u>5'x20'x15'</u>		LOGGED BY _____		
DEPTH WATER ENCOUNTERED <u>13.0</u> DATE _____		DATE(S) LOGGED <u>6/11/87</u>		
CLASSIFICATION GROUP SYMBOL (describe sample taken)	CLASSIFICATION AND DESCRIPTION OF MATERIAL  SEE USBR 5000, 5005	% PLUS 3 in (BY VOLUME)		
		3-8 in	5-12 in	PLUS 12 in
one 45-lb sack	<p>boulder-size fragments broke when dropped from backhoe bucket. Maximum dimension 450 mm. Material excavated with some difficulty below 8.0 ft due to less fracturing. Laboratory sample No. 3 taken from 7.0 to 7.8 ft depth along entire pit floor, material mixed and quartered to get sample. Sample had 71% fine to coarse gravel; 19% fines; 10% predominantly fine sand; trace of cobbles. Strong reaction with HCl. Laboratory Classification is Silty Gravel With Cobbles (GM).</p> <p>IN-PLACE CONDITION: Moist, heterogeneous, mostly gray with green lenses. Predominantly open bedding joints spaced approximately 6 in to 1.5 ft visible in trench wall. Many joints filled with silt, some joints tight, large blocks fell from vertical walls frequently. Some carbonate cementation between beds. Weathering is less intense below 9.0 ft causing difficult excavation. Below 8.0 ft material was mostly cobble and boulder-size fragments which broke when excavated.</p> <p>GEOLOGIC INTERPRETATION: Tertiary Green River Formation (Tgr)</p>			
10.5 feet				
SHALE	<p>10.5 to 14.0 ft. SLIGHTLY WEATHERED TO FRESH SHALE: Recovered as slightly weathered to fresh cobble to boulder-size gray angular fragments of shale. Fragments break with slight hammer blow. Material was very difficult to excavate requiring repeated passes with bucket in some layers. Could not excavate below 14.0 ft. Moderately to slightly fractured. Jointing is all vertical or parallel to bedding with approximately 20% silt-filled and most with reddish-brown staining on joint surfaces. Small seeps in trench walls below 13.0 ft. Walls slake slightly after 1 hour of exposure to drying. Very little sloughing occurred during the 1-hour exposure of vertical trench walls. Three-inch-thick bed of harder green shale encountered at bottom of trench. Excavated cobble and boulder-size fragments broke with very heavy hammer blow. No sample taken; no lab. classification.</p> <p>GEOLOGIC INTERPRETATION: Tertiary Green River Formation (Tgr)</p>			
14.0 feet				
REMARKS				

1/ Report to nearest 0.1 foot

OFD 844-241

Figure 11-32.—Geologic interpretation in test pit (sheet 8).

# LOGGING SOILS

7.1336 A (1-66) Bureau of Reclamation	LOG OF TEST PIT OR AUGER HOLE	HOLE NO. _____
FEATURE _____	PROJECT _____	
AREA DESIGNATION _____	GROUND ELEVATION _____	
COORDINATES N _____ E _____	METHOD OF EXPLORATION _____	
APPROXIMATE DIMENSIONS _____	LOGGED BY _____	
DEPTH WATER ENCOUNTERED 1/ _____ DATE _____	DATE(S) LOGGED _____	

SKETCH OF TRENCH WALL	DEPTH (FT)
<p><b>EAST WALL</b></p>	<p>0</p> <p>5</p> <p>10</p> <p>14.0</p>
<p>Pit oriented N-S            DIFFICULT TO SEE WALL BELOW 10 FT,      (S) = sample no. 1 location</p> <p style="text-align: right;">SCALE: 1" = 40'</p> <p style="text-align: center;">SKETCH BY JOE GEOLOGIST</p>	
REMARKS:	

1/ Report to nearest 0.1 foot

GPO 849-295

Figure 11-33.—Geologic interpretation in test pit using a geologic profile (3).

## FIELD MANUAL

The laboratory data should be reported on the log form as shown in the examples in figure 11-4.

The location of the sample and any laboratory tests performed need to be clearly described.

The coefficients of uniformity and curvature ( $C_u$ ,  $C_c$ ) are to be calculated and reported for coarse-grained soils containing 12 percent fines or less.

Gradation percentages and Atterberg limits are to be reported to the nearest whole number.

The fact that the classification is a laboratory classification needs to be indicated in the "classification group symbol" column.

The words "about" or "approximately" are not used in the word description.

### Soils with More Than 50 Percent Cobbles and Boulders

If the soil contains more than 50 percent (by volume) cobbles and/or boulders:

1. The first paragraph describes the total sample and includes the information on the cobbles and boulders. The information in the paragraph is the same as described previously for cobbles and boulders.
2. The words "COBBLES" or "COBBLES AND BOULDERS" are listed first in the classification group name:

## LOGGING SOILS

### COBBLES WITH POORLY GRADED GRAVEL COBBLES AND BOULDERS WITH SILTY GRAVEL

3. A classification symbol is *not* given. Where a report or form requires a classification symbol, use the words “cobbles” or “cobbles and boulders” instead.

An example of a word description for a soil with more than 50 percent cobbles and boulders is shown in figure 11-13.

### Special Cases for USCS Classification

Some materials that require a classification and description according to USCS should not have a heading that is a classification group name. When these materials will be used in, or have influence on, design and construction, they should be described according to the criteria for logs of tests pits and auger holes, and the classification symbol and group name should be in quotation marks. The heading should be as follows:

TOPSOIL  
DRILL PAD  
GRAVEL ROAD SURFACING  
MINE TAILINGS  
UNCOMPACTED FILL  
FILL

For example:

Classification symbol	Description
TOPSOIL	0.0 to 1.6-ft TOPSOIL—would be classified as “ORGANIC SOIL (OL/OH).” About 90%

## FIELD MANUAL

finer with low plasticity, slow dilatancy, low dry strength, and low toughness; about 10% fine to medium sand; soft, wet, dark brown, organic odor; roots present throughout strata; weak reaction with HCl.

### Reporting In-Place Density Tests

In-place density tests are sometimes performed in test pits in borrow areas so that in-place densities can be compared with the expected compacted densities for the embankment. The required volume of material needed from the borrow area can also be calculated. The in-place density is also used to evaluate the expansion or collapse potential for certain soils.

The density should be reported in the paragraph on in-place condition. Examples of the format are shown in figure 11-10. The upper example is used when only the density is determined. The lower example is used when a laboratory compaction test is also performed to calculate the percent compaction (or D value if rapid method is used) (USBR 7240, [1]). For cohesionless soils, similar information is reported for the maximum index density, the minimum index density, and the percent relative density.

If the in-place density test hole spans two (or more) depth intervals of classification, the data and comments for the test should be placed in the interval description corresponding to the top of the test hole. At the end of the information reported, the comment (in all capital letters) must be added: "NOTE: TEST EXTENDED INTO UNDERLYING INTERVAL." An in-place density test should not span different materials or layers.

## LOGGING SOILS

Because the laboratory compaction test is generally performed on the material removed from the test hole, note that the data are for a mixture of intervals by adding, "NOTE: COMPACTION TEST PERFORMED ON MATERIAL MIXED FROM TWO DIFFERENT INTERVALS."

The density units are lb/ft<sup>3</sup> or kilonewtons per cubic meter (kN/m<sup>3</sup>).

### Samples Taken

In addition to the brief description of the samples taken under the "Classification Group Symbol" column, a more complete description of any samples taken from each depth interval is included in the word description. The description should include the size of the sample, the location represented by the sample, and for each sample, how the sample was obtained (e.g., quartering and splitting).

An example of how to report the sample information for an auger hole is shown in figure 11-17. An example of how to report the sample information for a test pit or trench is shown in the section on word descriptions of undisturbed samples.

The approximate weight of samples should be stated.

### Measured Percentages of Cobbles and Boulders

If the percentages of the plus 3-inch particles are measured, not estimated, the percentages are reported to

the nearest 1 percent. In the word description for the plus 3-inch particles, do not use the term "about" before the percentages.

## FIELD MANUAL

The procedure for measuring the percent by volume of cobbles and boulders is given in the test procedure, USBR 7000, "Performing Disturbed Soil Sampling in Test Pits"[1]. This method is rarely used; percentages are usually estimated. It is not recommended that the percentages be measured for auger holes, since the mass of material recovered is generally insufficient to obtain a reliable gradation of plus 3-inch particles.

Figures 11-23 through 11-33 show a variety of logs of test pits using both the USCS and the geologic interpretation of the parent material. Note that USCS indicates that bedrock has been altered or weathered to a soil-like material. For engineering considerations, use the USCS but present the rock conditions as well.

## BIBLIOGRAPHY

- [1] Bureau of Reclamation, U.S. Department of the Interior *Earth Manual*, Part 2, third edition, 1990.
- [2] U.S. Department of Agriculture, *Agriculture Handbook No. 436*, Appendix I (Soil Taxonomy), December 1975.



## Chapter 12

# HAZARDOUS WASTE SITE INVESTIGATIONS

### General

Hazardous waste site investigations are geologic by nature. Site geology affects how the contaminants enter and migrate through the environment, controls the severity of the contamination problem, and determines if and how the contamination is remediated. An accurate characterization of site geology is critical for the successful removal and/or remediation of hazardous waste.

Investigations at hazardous waste sites use the same basic tenets of geology commonly applied in other areas of engineering geologic exploration. Even though these engineering geologic investigation techniques are universal, certain specialized criteria and regulations are required at hazardous waste sites which differ from traditional geologic work. This chapter assumes that accepted geologic procedures and equipment are used at hazardous waste sites and only discusses the variations in the planning, implementation, and documentation of geologic field work required at such sites. Documentation at hazardous waste sites plays a very prominent role and involves much more effort than other geologic investigations.

This chapter provides a general overview of documents, terminology, processes, requirements, and site specific factors for an investigation. This information can be used to better prepare or conduct a field program. Much information provided here is extracted from numerous Environmental Protection Agency (EPA) guidance documents. Hazardous waste investigations involve a

## FIELD MANUAL

myriad of documents and processes, mostly referred to by acronyms. See the appendix for an explanation of the more common acronyms.

In hazardous waste investigations, understanding the contaminant's physical and chemical properties is very important. These properties are useful for predicting pathways that allow contaminant migration through complex subsurface conditions. The understanding of subsurface conditions permits a program designed to better investigate and sample potentially contaminated soil, rock, and water.

### Common Terminology and Processes

The "typical" hazardous waste site remediation process involves several investigation phases. Each phase usually has a different emphasis and a different level of detail.

In general, there are two sets of regulations involved in hazardous waste site remediation: Resource Conservation Recovery Act (RCRA) and Comprehensive Environmental Response, Compensation, and Liability Act (CERCLA). RCRA regulations are largely confined to *operators and generators* of existing facilities, whereas CERCLA regulations are confined to the investigation of *abandoned* sites (Superfund). Although most Bureau of Reclamation (Reclamation) activities involve CERCLA investigations, wastes generated during the investigation may fall under RCRA regulations.

According to EPA guidelines (*Guidance for Performing Preliminary Assessments Under CERCLA*, EPA/540/G-91/013), EPA uses a structured program to determine appropriate response for Superfund sites. The CERCLA/

## HAZARDOUS WASTE

Superfund Amendments and Reauthorization Act of 1986 (SARA) process ideally evolves through the following phases: (1) discovery, (2) preliminary assessment, (3) site inspection, (4) hazard ranking, (5) remedial investigation, (6) feasibility study, (7) record of decision, (8) remedial design, (9) remedial action, and (10) operation and maintenance. Removal actions may occur at any stage.

### Documentation

Proper documentation at jobs involving hazardous waste is more important than at more "traditional" geologic investigation sites. The alleged low concentration values for risks to human health and the associated costs for contaminant testing are primary reasons for good documentation. Soil contaminants are typically reported in parts per million (ppm) (milligram per kilogram [mg/Kg]) and water contaminants are typically reported in parts per billion (ppb) (microgram per liter [ $\mu\text{g/L}$ ]). Since relatively low concentration levels may influence a decision for an expensive cleanup, the prevention of cross contamination and proper testing procedures is a necessity. Also, proper documentation is necessary for legally defensible data.

EPA has established documentation requirements for investigations. This chapter discusses the various documents needed by EPA under the Superfund program with an emphasis on the Sampling and Analysis Plan (SAP). Other documents such as the Health and Safety Plan (HASP), Spill Prevention Plan, and Community Relation Plan are often pertinent to the field operation.

The SAP will assist in preparing the required documents necessary before actual site work begins. Specific requirements for individual programs vary greatly, and

## FIELD MANUAL

common sense and regulatory concurrence dictate the level of detail needed. The EPA report *Guidance for Conducting Remedial Investigations and Feasibility Studies Under CERCLA*, Interim Final, October 1988 (EPA/540/G-89/004) provides additional details regarding EPA-required documentation.

### **Work Plan (WP)**

The WP includes a review of the existing data (background and study rationale), documents the decisions to be made during the evaluation process, and presents anticipated future tasks. The WP also designates responsibilities and sets the project schedule and cost. The primary use of the WP is to provide an agreed procedure to accomplish the work. The WP also provides other interested agencies (such as local government agencies) the opportunity to review proposed work. The WP is placed in the Administrative Record.

The WP may include an analysis and summary of the site background and physical setting, an analysis and summary of previous studies and response actions, a presentation of the conceptual site model (including the nature and extent of contamination), a preliminary assessment of human health and environmental impacts, additional data needs to conduct a baseline risk assessment, the preliminary identification of general response actions and alternatives, and the data needs for the evaluation of alternatives.

### **Sampling and Analysis Plan (SAP)**

The SAP provides the "nuts and bolts" of the procedures to be used at a site and must be site specific. The SAP should consist of three parts:

## HAZARDOUS WASTE

- (1) A Field Sampling Plan (FSP) that provides guidance for all field work by defining in detail the sampling and data-gathering methods to be used on a project.
- (2) An Analysis Plan (AP) that describes analysis of the collected data, such as the contaminant chemical data, the groundwater quality, and the geologic setting.
- (3) A Quality Assurance Project Plan (QAPP) that describes the quality assurance and quality control protocols necessary to achieve Data Quality Objectives (DQOs). Data Quality Objectives are qualitative and quantitative statements that clarify the study objective, define the type of data to collect, determine the appropriate collection conditions, and specify tolerable decision error limits on the quality and quantity of data needed to support a decision.

The level of detail contained within the SAP varies. Depending on the WP, the testing, analysis, and quality control may be delegated to a differing lead agency or contractor. Whether the SAP contains individual FSP, AP, and/or QAPP, the SAP indicates the field personnel roles and responsibilities, the acquired data goals, the analytical methods, and how these methods meet the DQOs. Guidance for the selection and definition of field methods, sampling procedures, and custody can be obtained from the EPA report *Compendium of Superfund Field Operations Methods*, December 1987 (EPA/540/P-87/001 or National Technical Information Service [NTIS] publication PB88-181557). This report is a compilation of demonstrated field techniques that have been used during remedial response activities at hazardous waste sites.

## FIELD MANUAL

The FSP specifies the actual data collection activities to be performed. The AP provides the details if changes in sampling methods or number of samples need to be made. If the AP is a separate document, the FSP should spell out in detail exactly how and why samples will be collected in the field.

Included with the SAP (sometimes as an appendix to the FSP) are the standard operating procedures (SOPs) to be used during the investigations. The SOPs describe, in item-by-item detail, the exact steps to be followed for each sampling procedure. Included in the SOPs are calibration and maintenance requirements for equipment to be used. Manufacturer's recommendations and usage manuals can serve as part of the individual SOPs. Further details regarding standardized tasks are given in the EPA Quality Assurance Technical Information Bulletin *Creating SOP Documents*.

The QAPP is a companion document typically written when the FSP is final. The QAPP ensures that data and the subsequent analyses are of sufficient quantity and quality to accurately represent the conditions at the site. The QAPP often describes policy, organization, and functional activities not addressed within the work plan.

The following is a suggested SAP format.

### Example Sampling and Analysis Plan

#### FSP

1. Site Background
2. Sampling Objectives
3. Sample Location and Frequency
4. Sample Designation
5. Sampling Equipment and Procedures
6. Sample Handling and Analysis

## HAZARDOUS WASTE

### AP

1. Objective(s) of the Data Collection
2. Analytical Methods and Software
3. Parameters Available and Required
4. Analytical Assumptions (Boundaries, Estimated Data)
5. Data Management and Manipulation
6. Evaluation of Accuracy (Model Calibration and/or Sensitivity Analysis)

### QAPP

1. Project Organization and Responsibilities
2. QA Objectives for Measurement
3. Sample Custody
4. Calibration Procedures
5. Data Reduction, Validation, and Reporting
6. Internal Quality Control
7. Performance and System Audits
8. Preventative Maintenance
9. Data Assessment Procedures
10. Corrective Actions
11. Quality Assurance Reports

### **Health and Safety Plan (HASP)**

Each field activity will vary as to amount of planning, special training, supervision, and protective equipment needed. The HASP, prepared to support the field effort, must conform to the Reclamation Safety and Health Standards. The site-specific HASP should be prepared concurrently with the SAP to identify potential problems early in the planning stage, such as availability of trained personnel and equipment. The HASP preparer should review site historical information along with proposed activities to identify potentially hazardous operations or exposures and to require appropriate protective measures. Appendix B of the *Occupational Safety and*

## FIELD MANUAL

*Health Guidance Manual for Hazardous Waste Site Activities* (National Institute for Occupational Safety and Health/Occupational Safety and Health Administration/U.S. Coast Guard/U.S. Environmental Protection Agency, 1985) provides an example of a generic format for an HASP. Commercial computer programs that allow preparers to "fill in the blanks" to produce rudimentary HASPs are also available.

A HASP should include, as appropriate, the following elements:

1. Name of site health and safety officer and names of key personnel and alternates responsible for site safety and health.
2. Listing of the potential contaminants at the site and associated risk(s).
3. A health and safety risk analysis for existing site conditions and for each site task and operation.
4. Employee training assignments.
5. A description of personal protective equipment to be used by employees for each of the site tasks and operations being conducted.
6. Medical surveillance requirements.
7. A description of the frequency and types of air monitoring, personnel monitoring, and environmental sampling techniques and instrumentation to be used.
8. Site control measures.
9. Decontamination procedures.
10. Standard operating procedures for the site.



## HAZARDOUS WASTE

11. A contingency plan that meets the requirements of 29 CFR 1910.120(l)(1) and (l)(2).
12. Entry procedures for confined spaces.
13. Local emergency numbers, notification procedures, and a clear map (and written instructions) showing the route to the nearest medical facility *capable of handling emergencies arising from a hazardous waste site*.

### **Spill Prevention Plan (SPP)**

All samples, equipment, cuttings, and other materials that have been exposed to potential contaminants must be decontaminated and/or tested and treated according to Applicable or Relevant and Appropriate Requirement (ARAR). Contingencies must be made for accidentally releasing and spreading contaminants into the environment during field activities at hazardous waste sites. Contaminants may originate from substances brought onto the site for specialized testing (e.g., standards for chemical testing), from accumulations of "free" contaminants, or from contaminated natural water which is released during sampling or investigations. Sufficient equipment (e.g., drums, absorbents, etc.) must be onsite to effectively control spills. In addition, key personnel should be identified for the control of spills. Paramount to such planning are spill prevention measures. Spill prevention plans may be incorporated into appropriate sections of a SAP or HASP, if desired.

### **Contaminant Characteristics and Migration**

A primary difference between conventional engineering geology investigations and hazardous waste investigations is that drilling methods may impact the contaminant sampling results and increase migration

## FIELD MANUAL

paths. Lubricants, fuels, and equipment may mask specific chemical testing or react with the contaminant of concern (COC). All samples, waste discharges, and equipment used in the investigations require evaluation in relation to the potential contaminant(s). The following unique site factors are also important.

### **Contaminant Properties**

Some contaminants are inherently mobile, for example, volatile organic compounds (VOCs). When released, VOCs can migrate rapidly through air, soil, and groundwater. Other contaminants, such as heavy metal solids, are less mobile. Heavy metals tend to accumulate on the surface of the ground. Although heavy metals may not readily migrate into and through the subsurface, heavy metals may still migrate through the air as airborne particles. Understanding the behavior of COCs is very important because behavior will significantly influence the ultimate design of the exploration program. For example, investigations to find gasoline, a light nonaqueous phase liquid (LNAPL), should concentrate on the water table surface. Dense, nonaqueous phase liquid (DNAPL) investigations should concentrate towards the bottom of the aquifer(s) or water table. Note that some contaminants react with investigation materials; e.g., TCE in high concentrations reacts with polyvinyl chloride (PVC) pipe.

When possible, the typical contaminant investigation will estimate the source type and location. The source type may be barrels, storage tanks, pipelines, injection wells, landfills, or holding ponds. In investigations that involve groundwater contamination, the investigation must address collecting samples of material that may be moving or have moved off site.

## HAZARDOUS WASTE

Identifying the contaminant and its behavior within the hydrogeologic environment must be kept foremost in mind while developing the program. Hydrochemical parameters such as density, diffusivity, solubility, soil sorption coefficient, volatilization (vapor pressure), and viscosity may impact the specific contaminant movement. Biological activities or meteoric waters may impact various COCs in the subsurface. Some contaminants degrade over time and under some environmental conditions. In some instances, the degradation product (TCE to vinyl chloride) is worse than the original product.

A general introductory geological hazardous waste investigation reference is the *Standard Handbook for Solid and Hazardous Waste Facility Assessments*, by Sara, 1994. A general introductory reference for environmental chemistry is *Fundamentals of Environmental Chemistry*, by Manahan, 1993. A reference on DNAPL materials is *DNAPL - Site Evaluation* by Cohen and Mercer, 1993. A reference for groundwater chemical and physical properties is *Groundwater Chemicals - Desk Reference*, by Montgomery, 1996. *Toxicological Profile Series* published by the U.S. Department of Health and Human Resources describes physical, chemical, and biological processes which effect contaminant fate and transport.

### Geologic Factors

The migration of contaminants is dependent on the subsurface materials and water. The arrangement of the geologic materials impacts the direction and flow rate of the contaminants and groundwater. Geologic factors such as stratigraphy, structure, and lithology control the occurrence and movement of water.

Various geologic factors to consider include: depth of soil, depth to bedrock, depth to the water table, seasonal

## FIELD MANUAL

variations in water table, water quality characteristics of site aquifers, mineralogic compositions of soil and rock, gradation, consolidation, and fracturing. Contaminant characteristics, such as property differences between solid or liquid materials, differences in liquid viscosity, or differences in liquid density relative to water, may influence how the contaminants interact with geologic factors and how the contamination plumes will behave.

### **Hydrologic Factors**

Groundwater flow is a function of precipitation, runoff, and infiltration (figure 12-1).

Groundwater flow occurs through two zones: the unsaturated (vadose or aeration) zone and the saturated zone. Each zone can be either soil or rock. Groundwater movement is affected by the characteristics of the material pore spaces (porosity) and the interconnectivity of the pore spaces (permeability). Water movement occurs under a hydraulic gradient.

Other terms often used in groundwater are transmissivity and storativity. Both terms are bulk terms used to describe the water over the entire hydrologic unit. Transmissivity is directly related to permeability. Storativity is a dimensionless value often incorrectly equated with specific yield. For a more detailed description, see the Bureau of Reclamation Water Resource Technical Publication, *Ground Water Manual*, second edition, 1995 or *Groundwater*, by Freeze and Cherry, 1979.

An unconfined aquifer, often referred to as a "water table" aquifer, has no overlying confining layer. Water infiltrating into the ground percolates downward through air-filled interstices of the vadose zone to the saturated zone. The water table, or surface of the saturated groundwater

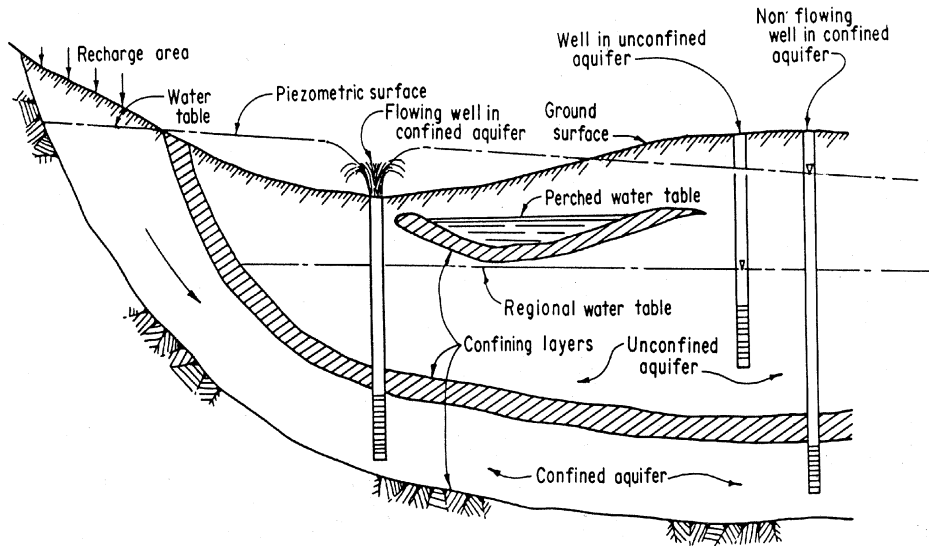


Figure 12-1. Aquifer types.

## FIELD MANUAL

body, is in contact with the atmosphere through the open pores of the material above and is in balance with atmospheric pressure.

A confined, or artesian, aquifer has an overlying, confining layer of lower permeability than the aquifer. Water in an artesian aquifer is under pressure, and when the confining layer is penetrated, the water will rise above the bottom of the confining bed to an elevation controlled by the aquifer pressure. If the confining layer transmits some water into adjacent layers, the aquifer is said to be a "leaky aquifer." A perched aquifer is created by beds of clay or silt, unfractured rock, or other material with relatively lower permeability impeding the downward percolation of water. An unsaturated zone is present between the bottom of the perching bed and the regional aquifer. Such an aquifer may be permanent or may be seasonal.

Aquifers are typically anisotropic; i.e., flow conditions vary with direction. In granular materials, the particle shapes, orientation, and the deposition process usually result in vertical permeability being less than horizontal permeability. The primary cause of anisotropy on a microscopic scale is the orientation of platy minerals. In some rock, the size, shape, orientation, and spacing of discontinuities and other voids may result in anisotropy. These factors should always be considered when modeling contaminant migration from hazardous waste sites.

After the natural flow conditions at a site are characterized, the presence of artificial conditions which may modify the flow direction or velocity of groundwater is determined. Such items as surface water impoundments and drainages may influence overall groundwater flow models. Also, if existing water wells are present in the area, pumping may be drawing the contaminants toward the wells. All possible influences affecting the

## HAZARDOUS WASTE

groundwater flow must be identified to model contaminant plume migration rates and paths.

### Classification and Handling of Materials

Classification of soils for engineering properties is described in chapter 3. Instructions for Logging Soils and Surficial Deposits (chapter 11) describes logging procedures, but there are two significant differences for hazardous waste investigations.

- (1) Logging of the soil is often limited to visual inspection of cuttings. The sampling protocol may prohibit the handling or poking of samples. Often the samples are sealed for chemical testing, and time for classification is restricted to the period when the sample is being packaged. Size of samples is kept to a minimum to reduce the amount of investigation-derived waste.
- (2) All material recovered or generated during an investigation (samples, cuttings, water, etc.) should be considered hazardous waste unless proven otherwise. Material removed should not be considered normal waste unless tested and permitted.

The RCRA statutory definition for hazardous waste is broad and qualitative and does not have clear bounds. Hazardous waste is defined as material meeting the regulatory definition contained in 40 CFR 261.3. However, the definitions of solid and hazardous waste contained in 40 CFR 261 are relevant only in identifying the waste. Material may still be considered solid or hazardous waste for purposes of other sections of RCRA. Some waste defined under the present regulatory statutes could become hazardous waste in the future.

## FIELD MANUAL

From the RCRA document, the definition of hazardous waste is any

*. . . solid waste or combination of solid wastes which because of its quantity, concentration, or physical, chemical, or infectious characteristics may: (A) cause, or significantly contribute to, an increase in mortality or an increase in serious irreversible, or incapacitating reversible, illness; or (B) pose a substantial present or potential hazard to humans or the environment when improperly treated, stored, transported, or disposed of, or otherwise managed.*

The level of contamination acceptable within the subsurface is based on a complex formula that involves the risk of exposure; toxicity, mobility, and volume of contaminants; and the cost of remediation. Soil and rock removed from a site cannot be returned to a site after the investigation has been completed.

Investigation waste water must be tested and handled under a different set of rules. If the water is mixed with cuttings, the material is considered a combination of solid wastes. If the water is discharged on a site, the water typically must meet drinking water standards. EPA currently requires that sole source aquifers have special project review criteria for Federal actions possibly affecting designated aquifers. Water withdrawn for public drinking water supplies currently falls under the Safe Drinking Water Act (SDWA) (Public Law 93-523) regulations, as amended and reauthorized (1974). (See 40 CFR 141 G for applicable water supply systems. See 40 CFR 143 for applicable water supply systems.) Note that the number of regulated constituents and their respective maximum contaminant levels (MCLs) are frequently updated.



## HAZARDOUS WASTE

Identifying and classifying hazardous waste is described in *Hazardous Waste*, by Wagner, 1990. Procedures for site evaluation are contained in *EPA Guidance for Conducting Remedial Investigation and Feasibility Studies Under CERCLA*, 1988.

### Field Sampling Protocol

One of the most difficult parts of any investigation is collecting representative samples. A sampling strategy must be efficiently and logically planned which delineates site location, number of samples collected, types of samples collected, testing methods to be used, and the duration and frequency of sampling. The difficulties of drilling in the right location and the problems associated with collecting representative samples is similar to traditional investigations. However, for hazardous waste investigation, the COC must be considered in both time and space. Statistical considerations should be part of the sampling program. The following are references for sampling statistical considerations:

Harvey, R.P. Statistical Aspects of Air Sampling Strategies. In: *Detection and Measurement of Hazardous Gases*; edited by C.F. Cullis and J.G. Firth. Heineman Educational Books, London, 1981.

Mason, B.J. *Protocol for Soil Sampling: Techniques and Strategies*. EPA Environmental Systems Laboratory, Contract No. CR808529-01-2. March 30, 1982. EPA-600/54-83-0020.

Smith, R., and G.V. James. *The Sampling of Bulk Materials*. The Royal Society of Chemistry, London. 1981.

## FIELD MANUAL

Environmental Protection Agency. *Handbook for Sampling and Sample Preservation of Water and Wastewater*. September 1982. EPA 600/4-82-029.

### Sampling Strategies

Investigators must determine the correct number and types of samples to be collected, the proper chemical testing methods (analytical procedures), and the proper sampling equipment before field activities begin. Sample containers, preservatives, sample quantities, and proper holding times are also dictated by the chosen methods.

Table 12-1 is a list of recommended sampling containers and holding times for various classes of contaminants in soils.

Several sampling strategies are available, each with advantages and disadvantages. *Random sampling* uses the theory of random chance probabilities to choose representative sample locations. This is appropriate when little information exists concerning the material, locations, etc. Random sampling is most effective when the number of sampling locations is large enough to lend statistical validity to the random selection.

*Systematic random sampling* involves the collection of randomly selected samples at predetermined, regular intervals (i.e., a grid). The method is a common sampling scheme, but care must be exercised to avoid over-sampling of one material or population type over others.

*Stratified sampling* is useful if data are available from previous investigations and/or the investigator has experience with similar situations. This scheme reduces the number of samples needed to attain a specified precision. Stratified sampling involves the division of the

## HAZARDOUS WASTE

Table 12-1. EPA recommended sampling containers, preservation requirements, and holding times for soil samples

Contaminant	Container <sup>1</sup> Preservation <sup>2</sup>	Holding time <sup>3</sup>
Acidity	P, G	14 days
Alkalinity	P, G	14 days
Ammonia	P, G	28 days
Sulfate	P, G	28 days
Sulfide	P, G	28 days
Sulfite	P, G	48 hours
Nitrate	P, G	48 hours
Nitrate-Nitrite	P, G	28 days
Nitrite	P, G	48 hours
Oil and grease	G	28 days
Organic carbon	P, G	28 days
<b>Metals</b>		
Chromium VI	P, G	48 hours
Mercury	P, G	28 days
Other metals	P, G	6 months
Cyanide	P, G	28 days
<b>Organic compounds</b>		
Extractables		
Including: Phthalates, nitro-samines, organic pesticides, PCBs, nitroaromatics, isophorone, polynuclear aromatics hydrocarbons, haloethers, chlorinated hydrocarbons, and tetrachlorodibenzo-p-dioxin (TCDD)	G, Teflon®-lined cap	7 days until extraction
		30 days after extraction

Footnotes at end of table.

## FIELD MANUAL

Table 12-1. EPA recommended sampling containers, preservation requirements, and holding times for soil samples (continued)

Contaminant	Container <sup>1</sup> Preservation <sup>2</sup>	Holding time <sup>3</sup>
Purgeables		
Halocarbons and aromatics	G, Teflon®-lined septum	14 days
Acrolein and acrylonitrile	G, Teflon®-lined septum	3 days
Orthophosphate	P, G	48 hours
Pesticides	G, Teflon®-lined cap	7 days until extraction  30 days after extraction
Phenols	G	28 days
Phosphorus	G	48 hours
Phosphorus, total	P, G	28 days
Chlorinated organic compounds	G, Teflon®-lined cap	7 days

<sup>1</sup> P = polyethylene, G = glass.

<sup>2</sup> All samples are cooled to 4 °C. Preservation is performed immediately upon collection. For composites, each aliquot preserved at collection. When impossible to preserve each aliquot, samples may be preserved by maintaining 4 °C until compositing and sample splitting is completed.

<sup>3</sup> Samples are analyzed as soon as possible. Times listed are maximum holding if analysis is to be valid.

Source: Description and Sampling of Contaminated Soils, EPA/625/11-91/002 (1991).

## HAZARDOUS WASTE

sample population into groups based on sample characteristics. The procedure involves handling each group or division separately with a simple random sampling scheme.

*Judgement sampling* introduces a certain amount of judgment into the sampling approach and should be avoided if a true random sample is desired. Judgment sampling allows investigator bias to influence decisions, which can lead to poor quality data or improper conclusions. If the local geology is fairly well understood, judgement sampling may provide the most efficient and cost-effective sampling scheme; however, regulatory concurrence, rationale, and proper documentation will be necessary.

*Hybrid sampling* is a combination of the types previously described. For example, an initial investigation of drums might be based on preliminary information concerning contents (judgement, stratified) and then random sampling of the drums within specific population groups (random). Hybrid schemes are usually the method of choice for sampling a diverse population, reducing the variance, and improving precision within each subgroup.

After the appropriate sampling scheme has been chosen, the specific type of samples necessary for characterization must be identified. The unique characteristics of the site COCs will play an important role in determining which media will be sampled. Some sampling devices are described in this manual or the *Earth Manual*, parts 1 and 2, USBR, 1990 and 1999. A summary of sampling devices is shown in table 12-2.

## FIELD MANUAL

Table 12-2. Summary of soil sampling devices

Sampling device	Applications	Limitations
<b>Hand-held samplers</b>		
Spoons and scoops	Surface soil samples or the sides of pits or trenches	Limited to relatively shallow depths; disturbed samples
Shovels and picks	A wide variety of soil conditions	Limited to relatively shallow depths
<b>Augers<sup>1</sup></b>		
Screw auger	Cohesive, soft, or hard soils or residue	Will not retain dry, cohesionless, or granular material
Standard bucket auger	General soil or residue	May not retain dry, cohesionless, or granular material
Sand bucket auger	Bit designed to retain dry, cohesionless, or granular material (silt, sand, and gravel)	Difficult to advance boring in cohesive soils
Mud bucket auger	Bit and bucket designed for wet silt and clay soil or residue	Will not retain dry, cohesionless, or granular material
Dutch auger	Designed specifically for wet, fibrous, or rooted soils (marshes)	

<sup>1</sup> Suitable for soils with limited coarse fragments; only the stoney soil auger will work well in very gravelly soil.

## HAZARDOUS WASTE

Table 12-2. Summary of soil sampling devices (continued)

Sampling device	Applications	Limitations
<b>Augers<sup>1</sup></b>		
In situ soil recovery auger	Collection of soil samples in reusable liners; closed top reduces contamination from caving sidewalls	Similar to standard bucket auger
Eijkelcamp stoney soil auger	Stoney soils and asphalt	
Planer auger	Clean out and flatten the bottom of predrilled holes	
<b>Tube samplers<sup>2</sup></b>		
Soil probe	Cohesive, soft soils or residue; representative samples in soft to medium cohesive soils and silts	Sampling depth generally limited to less than 1 meter
Thin-walled tubes	Cohesive, soft soils or residue; special tips for wet or dry soils available	Similar to Veihmeyer tube
Soil recovery probe	Similar to thin-walled tube; cores are collected in reusable liners, minimizing contact with the air	Similar to Veihmeyer tube

<sup>1</sup> Suitable for soils with limited coarse fragments; only the stoney soil auger will work well in very gravelly soil.

<sup>2</sup> Not suitable for soils with coarse fragments.

## FIELD MANUAL

Table 12-2. Summary of soil sampling devices (continued)

Sampling device	Applications	Limitations
<b>Tube samplers<sup>1</sup> (continued)</b>		
Veihmeyer tube	Cohesive soils or residue to depth of 10 feet (3 meters [m])	Difficult to drive into dense or hard material; will not retain dry, cohesionless, or granular material; may be difficult to pull from ground
Peat sampler	Wet, fibrous, organic soils	
<b>Power-driven samplers</b>		
Split spoon sampler	Disturbed samples from cohesive soils	Ineffective in cohesionless sands; not suitable for collection of samples for laboratory tests requiring undisturbed soil
<b>Thin-walled samplers</b>		
Fixed piston sampler	Undisturbed samples in cohesive soils, silt, and sand above or below water table	Ineffective in cohesionless sands
Hydraulic piston sampler (Osterberg)	Similar to fixed-piston sampler	Not possible to limit the length of push or to determine amount of partial sampler penetration during push

<sup>1</sup> Not suitable for soils with coarse fragments.



## HAZARDOUS WASTE

Table 12-2. Summary of soil sampling devices (continued)

Sampling device	Applications	Limitations
<b>Thin-walled samplers (continued)</b>		
Free piston sampler	Similar to stationary piston sampler	Not suitable for cohesionless soils
Open drive sampler	Similar to stationary piston sampler	Not suitable for cohesionless soils
Pitcher sampler	Undisturbed samples in hard, brittle, cohesive soils and cemented sands; representative samples in soft to medium cohesive soils, silts, and some sands; variable success with cohesionless soils	Frequently ineffective in cohesionless soils
Denison sampler	Undisturbed samples in stiff to hard cohesive soils, cemented sands, and soft rocks; variable success with cohesionless materials	Not suitable for undisturbed sampling of cohesionless soils or soft cohesive soils
Vicksburg sampler	Similar to Denison sampler except takes wider diameter samples	

In addition, the following references may be consulted for sample collection methods:

Environmental Protection Agency. *Characterization of Hazardous Waste Sites - A Methods Manual, Volume I - Site Investigations*. April 1985. EPA 600/4-84-075.

## FIELD MANUAL

Environmental Protection Agency. *Characterization of Hazardous Waste Sites - A Methods Manual: Volume II. Available Sampling Methods*. September 1983. EPA 600/4-83-040, PB84-126929.

Environmental Protection Agency. *A Compendium of Superfund Field Operation Methods*. December 1987. EPA 540/P-87-001, PB88-181557.

Samples can be either grab or composite samples. Grab samples are collected at a discrete point, representing one location and/or time interval. Composite samples are collected from several sources which are then accumulated to represent a broader area of interest. The requirements for testing will often dictate which sampling method is used. For example, composite samples of soil cannot be used for volatile compounds because portions of the contaminants may easily volatilize during collection.

Many soil samples are collected as grab samples. Soil samples should be collected from areas where dumping, spills, or leaks are apparent. Soil samples should be collected from areas upstream and downstream from suspected contaminant entry and in areas where sediment deposition is significant. Samples can be collected readily from the first 18 inches (450 mm) (depending upon the soil type) by using relatively simple tools, such as spades, scoops, and dredge scoops. If scoops are used for collecting surface soil samples, purchase enough scoops to use a new scoop for each sample rather than decontaminating scoops between samples. Not only is time saved, but cross contamination is kept to a minimum. The COC must also be considered. If sampling for heavy metals, metal scoops should not be used, or if sampling for semivolatiles, plastic scoops should be avoided. Samples from greater depths usually require more elaborate methods or equipment, such as test pits, hand augers, thin-wall tube samplers, hand or

## HAZARDOUS WASTE

power corers, bucket augers, cutting or wash samples, direct-push tools, etc. The nature of the geologic material to be sampled will influence significantly the methods to use, but every effort should be made to reduce the amount of investigation-derived waste generated from the sampling method. Direct-push sampling (such as the Geoprobe®) is preferable in that drill cuttings and drilling fluids are not generated.

A useful field pocket guide is available from EPA: *Description and Sampling of Contaminated Soils*, EPA/625/12-9/002, November 1991. This guide addresses soil characterization, description, sampling, and sample handling. Within this guide are general protocols for soil sample handling and preparation. The following are procedures from the guide:

### **Soil Sample Collection Procedures for Volatiles.**

1. Tube samples are preferred when collecting for volatiles. Augers should be used only if soil conditions make collection of undisturbed cores impossible. Soil recovery probes and augers with dedicated or reusable liners will minimize contact of the sample with the atmosphere.
2. Place the first adequate grab sample, maintaining and handling the sample in as undisturbed a state as possible, in 40-milliliter (mL) septum vials or in a 1-liter (L) glass wide mouth bottle with a Teflon®-lined cap. *Do not mix or sieve soil samples.*
3. Ensure the 40-mL containers are filled to the top to minimize volatile loss. Secure the cap tightly, but do not overtighten.

## FIELD MANUAL

4. Examine the hole from which the sample was taken with an organic vapor instrument after each sample increment. Record instrument readings.
5. Label and tag sample containers, and record appropriate data on soil sample data sheets (depth, location, etc.).
6. Place glass sample containers in sealable plastic bags, if required, and place containers in iced shipping container. Samples should be cooled to 4 degrees Centigrade ( $^{\circ}\text{C}$ ) as soon as possible.
7. Complete chain of custody forms and ship as soon as possible to minimize sample holding time. Scheduled arrival time at the analytical laboratory should give as much holding time as possible for scheduling of sample analyses.
8. Follow required decontamination and disposal procedures.

### **Soil Sample Collection and Mixing Procedures for Semivolatiles and Metals.**

1. Collect samples.
2. If required, composite the grab samples or use discrete grab samples.
3. If possible, screen the soils in the field through a precleaned O-mesh (No. 10, 2-millimeter [mm]) stainless steel screen for semivolatiles, or Teflon<sup>®</sup>-lined screen for metals.
4. Mix the sample in a stainless steel, aluminum (not suitable when testing for aluminum), or glass mixing container using appropriate tool (stainless steel spoon, trowel, or pestle).

## HAZARDOUS WASTE

5. After thorough mixing, place the sample in the middle of a relatively inexpensive 1-meter (m) square piece of suitable plastic, canvas, or rubber sheeting.
6. Roll the sample backward and forward on the sheet while alternately lifting and releasing opposite sides or corners of the sheet.
7. After thorough mixing, spread the soil out evenly on the sheet with a stainless steel spoon, trowel, spatula, or large knife.
8. Take sample container and check that a Teflon® liner is present in the cap, if required.
9. Divide the sample into quarters, and take samples from each quarter in a consecutive manner until appropriate sampling volume is collected for each required container. Separate sample containers would be required for semivolatiles, metals, duplicate samples, triplicate samples (split), and spiked samples.
10. Secure the cap tightly. The chemical preservation of solids is generally not recommended.
11. Label and tag sample containers, and record appropriate data on soil sample data sheets (depth, location, etc.).
12. Place glass sample containers in sealable plastic bags, if required, and place containers in iced shipping container. Samples should be cooled to 4 °C as soon as possible.
13. Complete chain of custody forms and ship as soon as possible to minimize sample holding time. Scheduled arrival time at the analytical laboratory

## FIELD MANUAL

should give as much holding time as possible for scheduling of sample analyses.

14. Follow required decontamination and disposal procedures.

### Water Quality Sample Collection Methods

**Surface Water Collection.** Surface water on or adjacent to a suspected hazardous waste site can yield significant information with minimal sampling effort. Surface water can reveal the presence of contamination from several pathway mechanisms. If only a knowledge of the presence or absence of contamination in the water is needed, the collection of grab samples will usually suffice. If the water source is a stream, samples also should be collected upstream and downstream from the area of concern. Additional monitoring of surface water is required of seeps, spills, surface leachates, etc. If the site has National Pollutant Discharge Elimination System (NPDES) outfalls, the discharges should be sampled.

Water quality samples are often the most important material collected at a site. Determining the appropriate number of samples and appropriate test method is critical to a successful program. A good guidance document to develop a water quality sampling program and provide the reasoning for collecting appropriate water samples is EPA's *Handbook, Ground Water*, volumes I and II, EPA/625/6-90/016. There are several factors to consider in the selection of appropriate sampling devices. Time and money are obvious factors; however, the data use, formation permeability, water depth, and contamination type are considerations. Water monitoring goals and objectives should be addressed, such as:

## HAZARDOUS WASTE

Is the investigation to determine source(s)?

Are the investigations included for a time critical removal action?

Have the potential contaminants been identified?

Will there be a follow up risk assessment and/or remediation?

Are there potential responsible parties (PRPs) involved?

Water samples can be routinely analyzed for current EPA listed priority pollutants. Alkalinity, acidity, total organic halogens, and chemical oxygen demand are often indicators of contamination. Routine tests can be used as screening techniques before implementing more costly priority pollutant analyses. Bioassessment samples, if needed, are described in *Rapid Bioassessment Protocols for Use in Streams and Rivers*, EPA/444/4-89-001. If technical impracticability (*Guidance for Evaluating the Technical Impracticability*, EPA Directive 9234.2-25, or natural attenuation are potential remediation options, additional water quality parameters may need testing consideration.

**Groundwater Collection.** Groundwater contamination is usually difficult and costly to assess, control, and remove. Monitoring wells sample a small part of an aquifer, depending on screen size, length, placement depth, pumping rates, and other factors. The use of wells and piezometers can introduce additional problems due to material contamination, inadequate construction, and uncertainties of the water zone sampled. Guarding against cross contamination of multiple aquifers is important. Proper well construction requires significant skill. General guidelines for design and construction of monitoring wells can be found in *American Society for Testing Materials (ASTM)*

## FIELD MANUAL

D5092-90, and guidelines for sampling can be found in RCRA *Groundwater Monitoring Draft Technical Guidance*, EPA/530-R-93-001. For general details on groundwater quality monitoring well construction, see figure 12-2. The location of the screen and designing and development of the screen and sand pack is extremely important in hazardous waste wells. Meeting the turbidity requirement of less than five nephelometric turbidity units (NTUs) is difficult to achieve in the best circumstances. Drilling exploration and monitoring wells in sequence from least to most contaminated areas is good practice because this minimizes the possibility of introducing contaminants into cleaner aquifers or areas.

Although the *Compendium of ERT Groundwater Sampling Procedures*, EPA/540/P-91/007, provides standard operating procedures for emergency response teams, the recommended water quality sampling procedures for groundwater should be in accordance with EPA's *Low-Flow (Minimal Drawdown) Ground-Water Sampling Procedures*, EPA/540/S-95/504. The Minimal Drawdown (MD) method requires using a submersible pump placed within a riser and not operated until the well has stabilized. The use of bailers and hand pumps, including automated hand pump systems for water quality sampling, is discouraged under the MD method.

Limiting water column disturbance is a primary reason for installing a dedicated submersible pump. Lowering a temporary sampling device into the water column creates a mini-slug test. The surge of water may induce sediments into the monitoring well. As a result, the water may not meet the five NTU limit that is part of the requirement for water quality monitoring wells. Sediments can significantly impact testing. If sediment



# HAZARDOUS WASTE

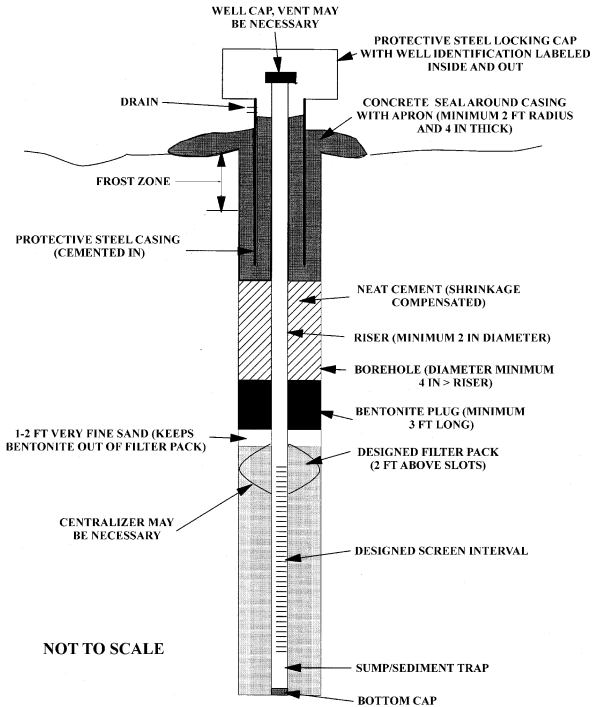


Figure 12-2. Typical monitoring well construction for water quality sampling.

## FIELD MANUAL

content is great, additional tests, such as comparing total versus dissolved solids, should be considered.

Some sampling devices may induce volatilization. Peristaltic pumps, bailers, or hand pumps in low-flow conditions can impact the test results for semi-volatile and volatile compounds. Peristaltic pumps may induce volatilization if the samples are lifted from depths greater than about 25 feet.

The MD method is the preferred sampling collection method because the method uses a low pumping rate (as low as 0.1 liter per minute) and attempts to limit drawdown to less than 0.3 foot. If the extraction rate exceeds the ability of the formation to yield water for low permeability wells, turbulent conditions can be induced within the borehole. Water may trickle and fall down the casing. This may potentially increase air exposure and can entrain air in the water.

Although preferred water quality sampling uses the MD method, other methods may be acceptable to EPA or other regulatory agencies. Devices such as bailers or peristaltic and hand pumps are routinely used at some sites. However, if these devices are used and surge the well, water sampling protocols often require that the well be purged of at least three well volumes of water prior to collecting a sample.

Whatever sample device is selected, stabilization of typical water quality parameters, such as pH, redox potential, conductivity, dissolved oxygen, and turbidity, are usually required. Which water quality parameters are specified may be dependent on the site conditions and regulatory requirements. The water extraction devices and procedures should be specified in the FSP and

## HAZARDOUS WASTE

correlated to match the site conditions, contaminants, and the regulatory agency requirements.

**Vadose Zone.** In addition to sampling aquifers at hazardous waste sites, significant information can be obtained by vadose zone sampling. Leachates from COCs migrate through the vadose zone toward the water table. Samples collected from this zone can indicate the types of contaminants present and can aid in assessing the potential threat to the aquifer below. The various types of vadose zone monitors can be used to collect water samples or interstitial pore space vapors for chemical analyses and to determine directional flow of COCs. The main advantage is that such sampling is relatively inexpensive, simple to do, and can begin supplying information before aquifer monitoring is started. The types of vadose zone monitors, their applications, and their use in satisfying the requirements of RCRA are discussed in *Vadose Zone Monitoring at Hazardous Waste Sites*, EMSL-LV KT-82-018R, April 1983.

### Geophysical Methods

Geophysical methods can be used effectively at hazardous waste sites to assist in defining the subsurface character of the site, to assist in the proper placement of monitoring wells, to identify buried containers and debris, and to decrease the safety risks associated with drilling into unknown buried materials. A good overview of the subject of geophysical methods for surveying hazardous waste sites is: *Geophysical Techniques for Sensing Buried Wastes and Waste Migration*, prepared for EPA by Technos, Inc., available from the National Water Well Association.

## FIELD MANUAL

### Miscellaneous Methods

Ambient concentrations of volatile and semivolatile organics, trace metals, and particulate matter in the air can provide important data on the atmospheric migration path and the populations at risk and can be used for source evaluations and personnel monitoring. Portable monitoring devices such as organic vapor analyzers, stain detector tubes, or other monitors can detect the presence of various atmospheric hazards. Other monitors commonly used at hazardous waste sites are explosimeters, oxygen indicators, and personal sampling pumps.

Other specialized sampling techniques may be necessary at hazardous waste sites to sample media normally not found in the geologic environment. Wipe samples may be used to document the presence of toxic materials and to determine that site or equipment decontamination has been adequate. Wipe sampling consists of rubbing a moistened filter paper, such as Whatman 541 filter paper, over a measured area of 15 in<sup>2</sup> (100 cm<sup>2</sup>) to 10 ft<sup>2</sup> (1 m<sup>2</sup>). The paper is then sent to a laboratory for analysis.

### Sample Analysis

Onsite laboratories and field analytical equipment, such as portable gas chromatographs (GCs) and immunoassay kits, can be very beneficial for rapid analyses. Rapid-analysis equipment, such as GCs, immunoassay, and colorimetric kits, are a cost-effective alternative for providing qualitative and semi-quantitative chemical data and for screening large numbers of samples prior to submittals for laboratory testing. Another beneficial use of field screening techniques is to provide general contaminant level data for samples to be tested in the laboratory. If a sample has a very high contaminant

## HAZARDOUS WASTE

concentration, the sample may have to be diluted before being analyzed to protect the laboratory instruments from costly contaminant saturation problems.

There are many standardized testing procedures and methods for hazardous waste evaluation. Table 12-3 lists some common method series. Each series contains numerous individual methods. There are over 25 series-500 (determination of organic compounds in drinking water) methods. Method 502.1 is for halogenated volatile organics (purgeable halocarbons) by GC (48 compounds); Method 502.2 is for nonhalogenated volatile organics by GC (6 compounds); Method 503.1 is for aromatic and unsaturated volatile organics (purgeable aromatics) by GC (28 compounds); Method 507 is for nitrogen and phosphorus containing pesticides by GC (66 substances).

The following references discuss some of the common methods:

*Methods for the Determination of Organic Compounds in Drinking Water.* EPA-600/4-88/039, December 1988 (500 Series).

*Guidelines Establishing Test Procedures for the Analysis of Pollutants Under the Clean Water Act.* 40 CFR Part 136, October 26, 1984 (600 Series, for effluent - wastewater discharged to a sewer or body of water).

*Test Methods for Evaluating Solid Waste.* SW-846, 2nd Edition, Revised, 1985 (8000 Series for groundwater, soil, liquid, and solid wastes).

*Methods for Chemical Analysis of Water and Wastes.* EPA-600/4-79-020, March 1983.

## FIELD MANUAL

Table 12-3. Common laboratory testing methods<sup>1</sup>

Method testing series	Analytes
100 - EPA method	Physical properties - water
200 - EPA method	Metals - water
300 - EPA method	Inorganic, non-metallics - water (i.e., alkalinity)
400 - EPA method	Organics - water (i.e., chemical oxygen demand, total recoverable petroleum hydrocarbons [TRPH])
500 - EPA method	Organic compounds in drinking water
600 - EPA method	Organic compounds in effluent
900 - EPA method	Biologic - water (i.e., coliform, fecal streptococcal)
1000 - SW-846 method	Ignitability, toxicity characteristic leaching procedure (TCLP), extractions, cleanup, headspace - solids
3000 - SW-846 method	Acid digestion, extractions, cleanup, headspace - solids
4010 - SW-846 method	Screening for pentachlorophenol by immunoassay - solids
5000 - SW-846 method	Organic (purge and trap, gas chromatograph/mass spectrometer [GC/MS], sorbent cartridges)
6000 - SW-846 method	Inductively coupled plasma (spectrometry)
7000 - SW-846 method	Metals - solid waste
8000 - SW-846 method	Organic compounds in solid waste
9000 - SW-846 method	Inorganics, coliform, oil and grease extractions - solids

<sup>1</sup> This list is not inclusive. Significant overlap and exceptions are present. Methods listed are basic guides to provide the investigator with the general structure of the testing method scheme. Numerous individual methods exist within each series.

## HAZARDOUS WASTE

*Standard Methods for the Examination of Water and Wastewater*, 19th edition, Greenberg; American Public Health Association, Washington, DC, 1995.

Reference guides are also available from several sources, such as the Trace Analysis Laboratory Reference Guides from Trace Analysis Laboratory, Inc., 3423 Investment Boulevard, No. 8, Hayward, California 94545, telephone (415) 783-6960.

An important consideration in planning any field investigation program is scheduling the anticipated activities. Sufficient time must be allowed for the peculiarities of hazardous waste work. Several factors must be considered: (1) time for establishing work zones and erecting physical barriers, (2) time for establishing equipment, personnel, and vehicle decontamination stations, (3) time needed to decontaminate equipment and personnel, (4) loss of worker efficiency due to safety monitoring, safety meetings, and the use of protective clothing, (5) documentation requirements and sample-handling procedures, and (6) inventory and procurement of specialized sample containers, preservative preparation, and reference standards, and equipment calibrations.

### **Safety at Hazardous Waste Sites**

A major factor during hazardous waste site investigations is the safety of both the general public and the site investigators. The following references may be of assistance:

## FIELD MANUAL

*Interim Standard Operation Safety Guides.* Revised September 1982, U.S. EPA, Office of Emergency and Remedial Response (OERR).

*Guidance Manual for Protection of Health and Safety at Uncontrolled Hazardous Substances Sites.* EPA, Center for Environmental Research Information (ORD) (in draft, January 1983).

*Reclamation Safety and Health Standards.* U.S. Department of the Interior, Bureau of Reclamation, Denver, Colorado, 1993.

*Chemical Substance Hazard Assessment and Protection Guide.* OWENS/URIE Enterprises, Inc., Henahan, Urie, & Farlern, Wheat Ridge, Colorado, 1994.

### **Sample Quality Assurance and Quality Control**

Sample QA procedures confirm the quality of the data by documenting that integrity is present throughout the sample history. Several sample types are used. *Field blanks* are samples of a "pure" substance, either water, solid, or air, which are collected in the field using the same procedures as are used for actual environmental samples. The purpose of the field blank is to ensure that outside influences are not contaminating the true samples (i.e., vehicular exhaust) during sampling. If "hits" are discovered in the field blank, the question arises whether contamination not associated with the site is affecting the true samples.

*Trip blanks* are samples of a "pure" substance (analyte-free deionized water which accompanies samples with volatile contaminants) prepared in a laboratory or other



## HAZARDOUS WASTE

controlled area and placed in a shipping container with environmental samples. The purpose of the trip blank is to ensure that samples were not cross contaminated during shipment and storage. "Hits" in a trip blank indicate that COCs were present in a container to a degree sufficient to infiltrate into the trip blank sample jar and, hence, possibly into true samples.

*Equipment blanks* are used when sampling equipment is cleaned and re-used for subsequent sample collection. The blanks verify the effectiveness of field cleaning procedures. The final rinse for the sampling equipment is often made with analyte-free deionized water. The rinse water is run on or through the sampling equipment, collected in appropriate containers and preserved. These samples are usually collected on a schedule, such as once every 10 episodes.

*Duplicates* are samples collected at the same time, in the same way, and contained, preserved, and transported in the same manner as a corresponding duplicate. Duplicates are used to determine the precision of the laboratory method and integrity of the sample from collection through testing. Duplicates are typically collected once every 10 samples.

*Matrix spikes* provide the best overall assessment of accuracy for the entire measurement system. For water investigation episodes, a laboratory usually prepares the spike samples, sends them to the site, and the spike sample(s) are included in the sample handling and shipping process. The samples are analyzed blind by the off-site laboratory. Matrix spikes can also be made from certified mixtures of a contaminant and clean soil in the field.

## FIELD MANUAL

All types of blanks and duplicates must be prepared in the same sample containers as actual samples including labeling and identification schemes so that the laboratory analyzes the sample without knowing that the samples are quality control (QC) samples (blind testing).

In addition to field QC samples, the analytical laboratory also uses QC samples. *Method blanks* are organic-free or deionized water carried through the analytical scheme like a sample. Method blanks measure contamination associated with laboratory activities. *Calibration blanks* are prepared with standards to create a calibration curve. *Internal standards* are measured amounts of certain compounds added after preparation or extraction of a sample. *Surrogates* are measured amounts of certain compounds added before preparation or extraction of a sample to determine systematic extraction problems. *Duplicates and duplicate spikes* are aliquots of samples subjected to the same preparation and analytical scheme as the original sample. *Laboratory control standards (LCSs)* are aliquots of organic-free or deionized water to which known amounts of analyte have been added. LCSs are subjected to the sample preparation or extraction procedure and analyzed as samples.

Field, laboratory, data validation, and report presentation documents must be meticulously maintained during hazardous waste site investigations. All field activities should be recorded in bound, consecutively numbered log books. Each entry should be made with indelible ink, and all strike outs should be made by a single line which allows the original error to be legible and initialed and dated by the person making the correction. Entries should include date, weather conditions, personnel involved with the activity, the type of activity being performed, unusual circumstances or variations made to the SOPs, and data appropriate to the activity being

## HAZARDOUS WASTE

performed. This is a diary of all activities on a site. The investigator responsible for the activity is responsible for maintaining the field log book. An important purpose of the field log book is to document any changes made to SOPs. If such changes may affect data quality, concurrence with managers or regulatory personnel is required in writing. All records must be under control at all times. Unique project numbers should be assigned to all log books, documents, and reports. All records must be maintained and custody documented so that unauthorized changes or tampering are eliminated. Log book entries should be photocopied on a regular schedule to ensure that field data are not lost if the original book is lost or destroyed.

Activities during an investigation must be reviewed to ensure that all procedures are followed. System audits should consist of inspections of training status, records, QC data, calibrations, and conformance to SOPs. System audits are performed periodically on field, laboratory, and office operations. Each major investigation type should be subject to at least one system audit as early as practicable. Performance audits include evaluation and analysis of check samples, usually from laboratory activities. Readiness reviews occur immediately prior to beginning each type of field activity to assess the readiness of the team to begin work. A checklist of prerequisite issues, such as necessary equipment, controlled documents, training, assignments, spare parts, field arrangements, etc., are discussed and documented.

If any weaknesses or deficiencies are identified, the investigator must resolve them before field activities proceed.

# FIELD MANUAL

## Sample Management

There must be control and documentation of all samples after the environmental samples are collected in the field. The proper quantity of a sample must be collected to have sufficient volume for the subsequent analysis. The proper sample container and preservative must be used so that sample integrity is not compromised. Many types of samples (e.g., volatiles) must be cooled, usually to 4 °C, throughout their history after collection. The proper analytical methods must be identified to obtain the desired result. The laboratory must handle and track the received samples in a timely and accurate manner to ensure that the results are correct.

### Sample Custody

Sample custody is a prime consideration in the proper management of samples. Sample custody is designed to create an accurate, written, and verified record that can be used to trace the possession and handling of the samples from collection through data analyses and reporting. Adequate sample custody is achieved by means of QA-approved field and analytical documentation. A sample is considered in custody if the sample is (1) in one's actual physical possession, (2) is in one's view after being in one's physical possession, (3) is in one's physical possession and then locked up or otherwise sealed so that tampering will be evident, or (4) is kept in a secure area restricted to authorized personnel only. Personnel who collect samples are personally responsible for the care and integrity of these collected samples until the samples are properly transferred or dispatched. To document that samples are properly transferred or dispatched, sample identification

## HAZARDOUS WASTE

and chain of custody procedures must be followed. Sample custody in the field and in transit involves the steps described below.

**Sample Identification.** The sample must first be properly and uniquely identified. Sample identification entails establishing a scheme which ensures that each sample is identified in such a way that one sample cannot be mistaken for another. Examples of sample labels are shown in figure 12-3. Labels must be filled out immediately after the sample is collected to ensure that containers are not later misidentified. Indelible ink must be used on all labels, and the writing must be legible. For samples which require preservation, the sample labels must have a space on the label reserved for noting the preservative added, or other treatments, such as filtering, compositing, etc. Labels can be removed from a sample jar during shipment, especially if the accompanying ice melts and saturates the shipping labels. Double-label samples such as sacked soil whenever possible or completely wrap the label over the sample bottle with wide, water-proof tape. Also record the collection of each sample in the field log book and chain of custody records.

**Chain of Custody.** Once all samples for a specific sampling task have been collected, the sampler(s) will complete the chain of custody record (figure 12-4). Specific procedures for completing this form should be included in the work plan documents specific to the project. This record accompanies the samples to their destination. All samples typically are transferred from the sample transport container (e.g., cooler) and kept in the exclusion zone until transferred to a noncontaminated sample transport container in the contamination reduction zone. The samples, with accompanying documentation, are

# FIELD MANUAL

## Soil Sample Identification Label

Bureau of Reclamation Chemistry Laboratory Sample ID	
Project	_____
Feature (dam, river, etc)	_____
Sampling date	_____ Time _____
ID:	_____
	_____
Analysis Request	_____
Comments:	_____
	_____

## Water Sample Identification Labels

*****TRACE ELEMENTS*****	
DATE _____	SITE _____
TIME _____	
SAMPLED _____	SAMPLER _____
PLASTIC, 250 ML, RAW	
ACIDIFIED WITH HNO <sub>3</sub>	

*****UNTREATED SAMPLE*****	
DATE _____	SITE _____
TIME _____	
SAMPLED _____	SAMPLER _____
PLASTIC, 250 ML, RAW	

Figure 12-3. Soil and water sample identification labels.

### Chain of Custody Record

Project Manager			Project name					Batch identification												
Samped by and title (signatures)								Date Time					Remarks	Initials and date sample destroyed						
Laboratory																				
Field identification	Date collected	Time	Lab identification	Sample type																

Relinquished by (signature)	Date	Time	Relinquished by (signature)	Date	Time	Relinquished by (signature)	Date	Time
Received by (signature)	Date	Time	Received by (signature)	Date	Time	Received by lab (signature)	Date	Time

Point of contact: \_\_\_\_\_

Remarks: \_\_\_\_\_

DISTRIBUTION: Original: Accompanies shipment. Pink copy: Field records. Yellow copy: Associate laboratory

Sample shipped via

Priority Mail     Bus     Other  
 Express Mail     UPS

HAZARDOUS WASTE

**Figure 12-4. Chain of custody record.**

## FIELD MANUAL

then prepared for either distribution to the onsite laboratory or shipment to an analytical laboratory in the support zone.

When transferring the possession of samples, the individuals relinquishing and receiving the samples will sign, date, and note the time on the chain of custody record. This record documents sample custody transfer from the sampler to the analyst. Note that some commercial shippers (such as Federal Express) do not sign chain of custody records but do prepare separate shipping documents which indicate receipt of the cooler(s). When samples are passed among field personnel while still onsite, chain of custody records do not need to be signed, as long as physical possession is retained by identified, responsible personnel during transit of the container(s).

### **Packaging**

Samples must be packaged properly for shipment and dispatched to the appropriate laboratory for analysis; a separate record accompanies each shipment. Samples within shipping containers will be sealed for shipment to the laboratory by using custody seals (figure 12-5). Seals are made of paper, with adhesive backing, so that they will tear easily to indicate possible tampering. There are two methods of using custody seals. One method is to place several sample containers in individual plastic bags (or boxes) within the shipping container and then place the custody seal along the only opening of each bag. An advantage of this scheme is that the seal is not exposed to outside influences; but the disadvantages are that the bags are very pliable, and shifting may cause the seal to break, and the seal may become immersed in water if ice melts around the bags. The second method is to place the custody seal on the outside of the cooler, along a seam of




 <p>UNITED STATES BUREAU OF RECLAMATION OFFICIAL SAMPLE SEAL</p>	SAMPLE NO.	DATE
	SIGNATURE	
	PRINT NAME AND TITLE (Inspector, Analyst or Technician)	
SEAL BROKEN BY		DATE
<small>7-2284 (3-81) Bureau of Reclamation</small>		

Figure 12-5 Custody seal.

## FIELD MANUAL

the lid. The advantage of this method is that the seal is stuck to the solid body of the cooler. The main disadvantage is that the seal is exposed to handling by the shipping company and other personnel from the field to the laboratory. The seal must not be broken accidentally because a broken seal will place all the samples represented by the seal in jeopardy of disqualification due to tampering. An option may be to place clear tape over the seal as added protection.

The samples within a container must be packed to avoid rattling and breakage. Styrofoam "popcorn" or bubble pack sheeting are acceptable packing materials. Organic packing materials, including sawdust, should be avoided due to the possibility of becoming wet from melting ice. Each sample jar should be wrapped such that jar-to-jar contact is avoided. Also, it is usually desirable to place ice at the bottom of the container, and place the samples above the ice, with a water-proof barrier between the ice and samples. This way, if the ice melts, there is a lessened probability of the samples becoming immersed. If time is available, ice should be double-wrapped, using several "ice packages" to lessen spillage potential. Chemical ice packs and dry ice should be avoided, if possible, to lessen the chance of chemical contamination. The chain of custody record must accompany each container and list only the samples contained within the specified cooler. The original chain of custody record should be sealed in a "zip-lock" plastic bag and taped to the inside top of the cooler lid. When the laboratory opens a cooler, the number and identification of each sample contained within the cooler must exactly match the corresponding chain of custody record. A copy of the chain of custody record is to be retained by the investigator or site manager, and a copy is also retained by the laboratory. A three-carbon copy type chain of custody record is best.

## HAZARDOUS WASTE

The water drain at the lower edge of the cooler must be sealed so there is no possibility of the drain opening. If any leakage occurs from a cooler containing environmental samples, the shipping company will cease shipment and delay the arrival of the samples, possibly exceeding the holding times of the contained samples. A shipping company may have unique requirements; but as a general rule, the weight of a cooler should not exceed 50 to 70 pounds. If sent by mail, the package must be receipt requested. If sent by common carrier, a government bill of lading can be used. Proper shipment tracking methods must be in place. Copies of all receipts, etc., must be retained as part of the permanent documentation.

Upon arrival at the laboratory, the containers will be opened, the custody seals inspected and documented, and any problems with chain of custody, temperature, or sample integrity noted. The laboratory custodian will then sign and date the chain of custody record and enter the sample identification numbers into a bound, paginated log book, possibly assigning and cross-referencing a unique laboratory number to each sample received. The laboratory then controls the samples according to the SOPs specified in their work plan documents.

### Decontamination

Decontamination consists of removing contaminants and/or changing their chemical nature to innocuous substances. How extensive decontamination must be depends on a number of factors, the most important being the type of contaminants involved. The more harmful the contaminant, the more extensive and thorough decontamination must be. Less harmful contaminants may

## FIELD MANUAL

require less decontamination. Only general guidance can be given on methods and techniques for decontamination. The exact procedure to use must be determined after evaluating a number of factors specific to the site.

When planning site operations, methods should be developed to prevent the contamination of people and equipment. For example, using remote sampling techniques, using disposable sampling equipment, watering down dusty areas, and not walking through areas of obvious contamination would reduce the probability of becoming contaminated and require a less elaborate decontamination procedure.

The initial decontamination plan is usually based on a worst-case situation. During the investigations, specific conditions are evaluated including: type of contaminant, the amount of contamination, the levels of protection required, and the type of protective clothing needed. The initial decontamination system may be modified by adapting it to actual site conditions.

## APPENDIX

# ABBREVIATIONS AND ACRONYMS COMMONLY USED IN BUREAU OF RECLAMATION ENGINEERING GEOLOGY AND RELATED TO HAZARDOUS WASTE

(Many are modified from A.A.P.G. Committee  
on Stratigraphic Correlations)

### Acronyms and Abbreviations Commonly Used in Bureau of Reclamation Engineering Geology

---

---

A	Apparent trace
acre-ft	Acre-feet
acre-ft/d	Acre-feet per day
acre-ft/yr	Acre-feet per year
AGI	American Geological Institute
AP	Analysis Plan
APSRS	Aerial Photography Summary Record System
ARAR	Applicable or Relevant and Appropriate Requirement
ASCS	Agricultural Stabilization and Conservation Service
ASTM	American Society for Testing Materials

## FIELD MANUAL

ASTM/USCS	American Society for Testing Materials/ Unified Soil Classification System
b	As a suffix, with boulders
BJ	Bedding joint
c	As a suffix, with cobbles
CADD	Computer assisted design and drafting
CERCLA	Comprehensive Environmental Response, Compensation, and Liability Act
CH	Fat clay
CL	Lean clay
CL	Cleavage
CL-ML	Silty clay
cm	Centimeter
cm <sup>2</sup>	Square centimeter
cm/s	Centimeter per second
COC	Contaminant of concern
D	Dip trace
DI	Durability Index
DLS	Detail line survey
DNAPL	Dense, nonaqueous phase liquid
DQOs	Data Quality Objective

## ABBREVIATIONS

EPA	Environmental Protection Agency
ft	Foot
ft <sup>2</sup>	Square foot
ft <sup>3</sup>	Cubic foot
ft <sup>3</sup> /s	Cubic foot per second
ft/yr	Feet per year
FJ	Foliation joint
FSP	Field Sampling Plan
FZ	Fracture zone
g	As a prefix, gravelly; as a suffix, with gravel
gal	Gallon
gal/min	Gallon per minute
GC	Clayey gravel
GC-GM	Silty, clayey gravel
GC/MS	Gas chromatograph/mass spectrometer
GC	Gas chromatograph
GM	Silty gravel
GP	Poorly graded gravel
GP-GC	Poorly graded gravel with clay
GP-GM	Poorly graded gravel with silt

## FIELD MANUAL

GPS	Global Positioning System
GW	Well graded gravel
GW-GC	Well graded gravel with clay
GW-GM	Well graded gravel with silt
H1	Extremely hard
H2	Very hard
H3	Hard
H4	Moderately hard
H5	Moderately soft
H6	Soft
H7	Very soft
HASP	Health and Safety Plan
HCl	Hydrochloric acid
ID	Inside diameter
IF	Incipient fracture
IJ	Incipient joint
in	Inch
in <sup>2</sup>	Square inch
in <sup>3</sup>	Cubic inch
JT	Joint



## ABBREVIATIONS

k	Hydraulic conductivity
kPa	Kilopascal
kg/cm <sup>2</sup>	Kilogram per square centimeter
km	Kilometer
kN	Kilonewton
kN/m <sup>3</sup>	Kilonewton per cubic meter
L	Liter
lb/in <sup>2</sup>	Pound-force per square inch
lb/in <sup>2</sup>	Pounds per square inch
lb/ft <sup>3</sup>	Pounds per cubic foot
LCS	Laboratory control standard
LL/PI	Liquid limit/plasticity index
LNAPL	Light nonaqueous phase liquid
L/sec	Liter per second
m	Meter
m <sup>2</sup>	Square meter
m <sup>3</sup>	Cubic meter
m <sup>3</sup> /s	Cubic meter per second
m <sup>3</sup> /yr	Cubic meter per year
MB	Mechanical break

## FIELD MANUAL

MCL	Maximum contaminant level
mg/Kg	milligram per kilogram
MH	Elastic silt
mi	Mile
ML	Silt
mm	Millimeter
NAD	North American Datum
NASC	North American Stratigraphic Code
NCC	National Cartographic Information Center
NGI	Norwegian Geotechnical Institute
NPDES	National Pollutant Discharge Elimination System
NTIS	National Technical Information Service
NTU	Nephelometric turbidity unit
OD	Outside diameter
OERR	Office of Emergency and Remedial Response
OH	Organic clay
OL	Organic silt
OSHA	Occupational Safety and Health Administration

## ABBREVIATIONS

Pa	Pascals
PRP	Possible responsible party
PCB	Pentachlorobenzene
ppb	Part per billion
ppm	Part per million
PSI	Pound-force per square inch
PT	Peat
PVC	Polyvinyl chloride
QAPP	Quality Assurance Project Plan
QC	Quality control
RCRA	Resource Conservation Recovery Act
Reclamation	U.S. Bureau of Reclamation
RF	Random fracture
RMR	Rock Mass Rating System Geomechanics Classification
RQD	Rock Quality Designation
RSR	Rock Structure Rating
S	Strike trace
s	As a prefix, sandy; as a suffix, with sand
SAP	Sampling and Analysis Plan
SC	Clayey sand

## FIELD MANUAL

SC-SM	Silty, clayey sand
SDWA	Safe Drinking Water Act
SM	Silty sand
SOP	Standard operating procedures
SP	Poorly graded sand
SP-SC	Poorly graded sand with clay
SPT	Standard Penetration Test
SP-SM	Poorly graded sand with silt
SW	Well graded sand
SW-SC	Well graded sand with clay
SW-SM	Well graded sand with silt
TBM	Tunnel boring machine
TCE	Trichloroethylene
TCLP	Toxicity characteristic leaching procedure
TRPH	Total recoverable petroleum hydrocarbons
URCS	Unified Rock Classification System
USCS	Unified Soil Classification System
USDA	United States Department of Agriculture
USGS	United States Geological Survey

## ABBREVIATIONS

VOC	Volatile organic compound
WP	Work plan
yd <sup>3</sup>	Cubic yard
µg/L	microgram per liter
µm	Micrometer
EC	degrees Centigrade
EF	degrees Fahrenheit

### **Commonly Used Acronyms and Abbreviations Related to Hazardous Waste**

---

---

ARAR	Applicable or relevant and appropriate requirement
AST	Above ground storage tank
AP	Analysis plan
BADT	Best available demonstrated technology
BAT	Best available technology or best available treatment
CAA	Clean Air Act
CERCLA	Comprehensive Environmental Response, Compensation, and Liability Act (Superfund)

## FIELD MANUAL

CERCLIS	Comprehensive Environmental Response, Compensation, and Liability Information System
COD	Chemical oxygen demand
CRP	Community Relations Plan
CRZ	Contaminant reduction zone
CWA	Clean Water Act (aka FWPCA)
DQO	Data quality objectives
EPA	Environmental Protection Agency
FS	Feasibility study
FSP	Field sampling plan
HASP	Health and safety plan
HRS	Hazard ranking system
HS	Head space (analysis)
IDL	Instrument detection limit
IDLH	Immediately dangerous of life and health
LEL	Lower explosive limit
LFL	Lower flamability limit
LUST	Leaking underground storage tank
MCL	Maximum contaminant level (SDWA)
MDL	Method detection limit

## ABBREVIATIONS

MSDS	Material safety data sheet
NCR	Nonconformance report
ND	Nondetect
NFRAP	No further remedial action planned
NPDES	National Pollutant Discharge Elimination System
NPL	National Priority List
NTIS	National Technical Information Service
OSWER	Office of Solid Waste and Emergency Response
PA	Preliminary assessment
PCB	Polychlorinated biphenyl
PEL	Permissible exposure limit or personal exposure limit
PPB	Parts per billion
PPM	Parts per million
PPT	Parts per trillion
PPT <sub>h</sub>	Parts per thousand
PRP	Potentially responsible party
PS	Point source
PVC	Polyvinyl chloride

## FIELD MANUAL

PWS	Public water supply or public water system
QA	Quality assurance
QAPP	Quality assurance project plan
QC	Quality control
QL	Quantitation limit
RA	Remedial action or removal action or risk assessment
RCRA	Resource Conservation Recovery Act
RD	Remedial design
RfD	Reference dose
RI	Remedial investigation
RMCL	Recommended maximum contaminant levels
RME	Reasonable maximum exposure
ROD	Record of decision
RP	Responsible party
RPM	Remedial project manager
RQ	Reportable quantity
SAP	Sampling and analysis plan
SAR	Start action request



## ABBREVIATIONS

SARA	Superfund Amendments and Reauthorization Act of 1986
SAS	Special analytical services
SDWA	Safe Drinking Water Act
SF	Slope factor
SI	Site inspection
SOP	Standard operating procedures
SQG	Small quantity generator
STEL	Short-term exposure limit
STP	Sewage treatment plant
SVOC	Semivolatile organic chemical (Compound)
SWDA	Solid Waste Disposal Act
TCE	Trichloroethylene
TCL	Target compound list
TCLP	Toxicity characteristic leaching procedure
TD	Toxic dose
TDS	Total dissolved solids
THC	Total hydrocarbons
TIC	Tentatively identified compound
TLV	Threshold limit value

## FIELD MANUAL

TOA	Trace organic analysis
TOC	Total organic carbon or total organic compound
TOX	Total organic halogens
TPY	Tons per year
TRPH	Total recoverable petroleum hydrocarbons
TSCA	Toxic Substances Control Act
TSDF	Treatment, storage, and disposal facility
TSS	Total suspended solids
UEL	Upper explosive limit
UFL	Upper flamability limit
UST	Underground storage tank
VOC	Volatile organic chemical (compound)
WP	Work plan
WSRA	Wild and Scenic Rivers Act
WWTP	Wastewater treatment plan