



EP-USP

PEF2602
Estruturas na Arquitetura II - Sistemas Reticulados
2º Semestre 2015



FAU-USP

PÓRTICOS

Ruy Marcelo de Oliveira Pauletti
Leila Cristina Meneghetti
23/11/2015

www.lmc.ep.usp.br/disciplinas/pef2602

The Top 15 Skylines in the World v3.0
(from Luigi di Derio, www.diserio.com)
1. Hong Kong, China: Metro/Urban Population: 6.9 million



2. Chicago, USA: Metro/Urban Population: 9.5 million



3. Shanghai, China: Metro/Urban Population: 13.1 million



4. New York City, USA : Metro/Urban Population: 21.0 million



5. Tokyo, Japan: Metro/Urban Population: 32.0 million



6. Singapore: Metro/Urban Population: 3.8 million



7. Toronto, Canada: Metro/Urban Population: 5.1 million



8. Kuala Lumpur, Malaysia: Metro/Urban Population: 1.5 million



9. Shenzhen, China: Metro/Urban Population: 4.2 millions



10. Seoul, South Korea: Metro/Urban Population: 20.8 million



São Paulo – mar de prédios



Pórticos

Arranjo de barras predominantemente horizontais (vigas) e verticais (pilares), conectadas de modo a permitir a interação entre forças e momentos fletores (nós rígidos)

Os membros de um pórtico são em geral capazes de resistir a esforços normais, cortante e de flexão, e são comumente usados em padrões repetitivos, resultando em estruturas hiperestáticas.

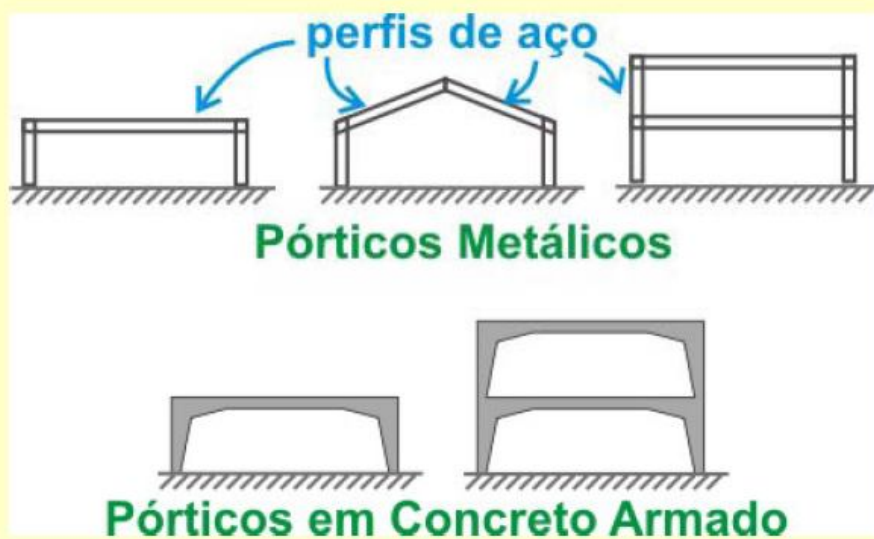
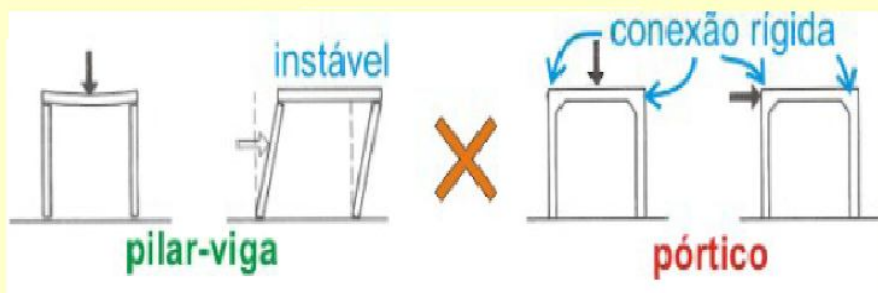

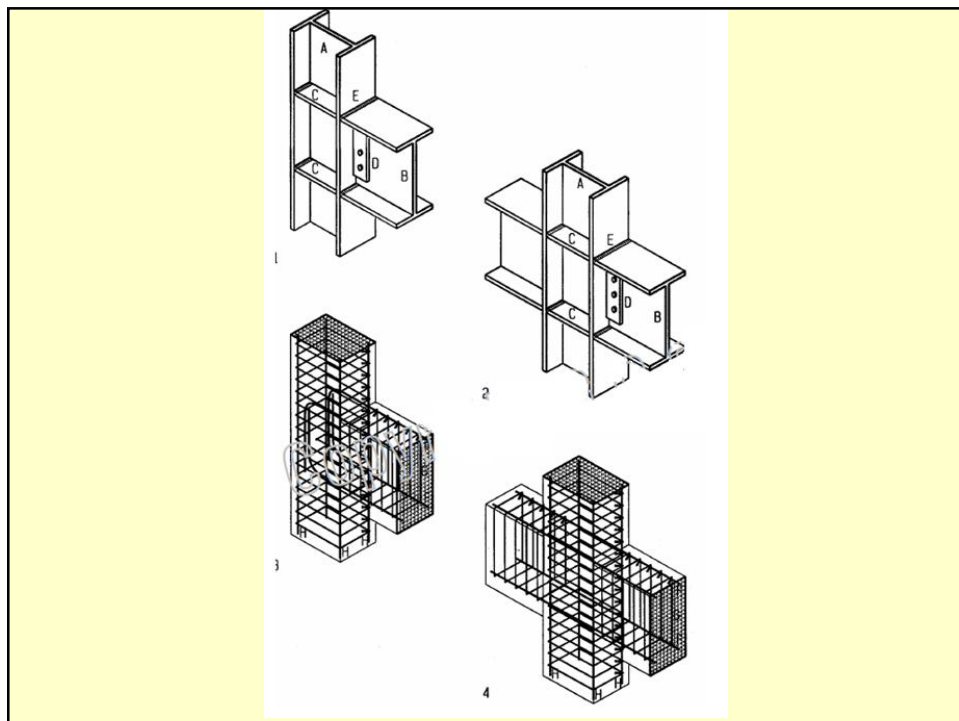
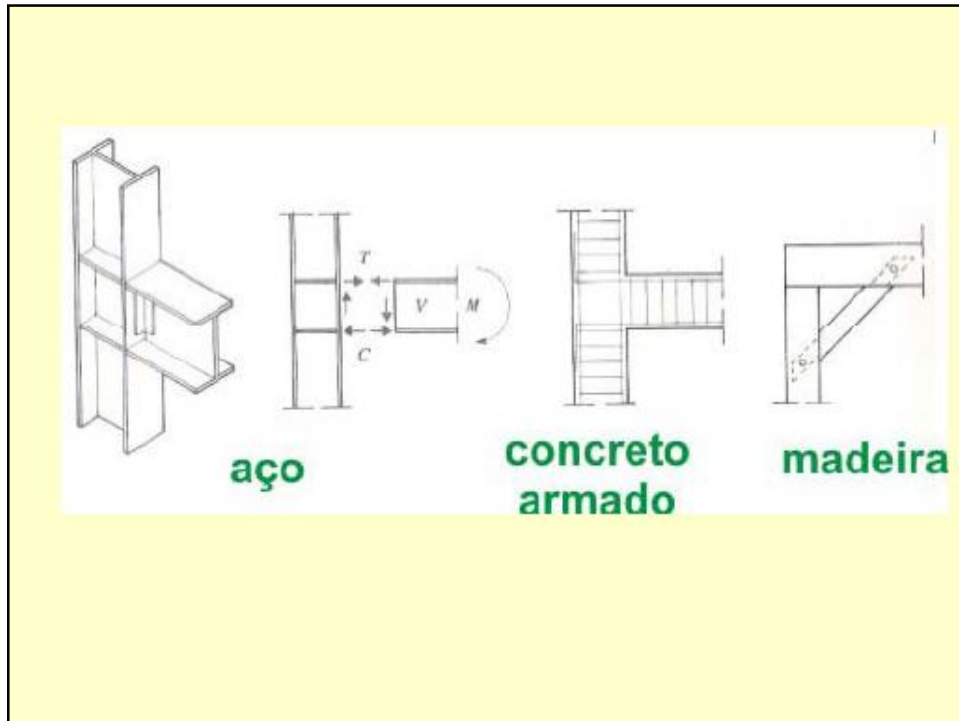

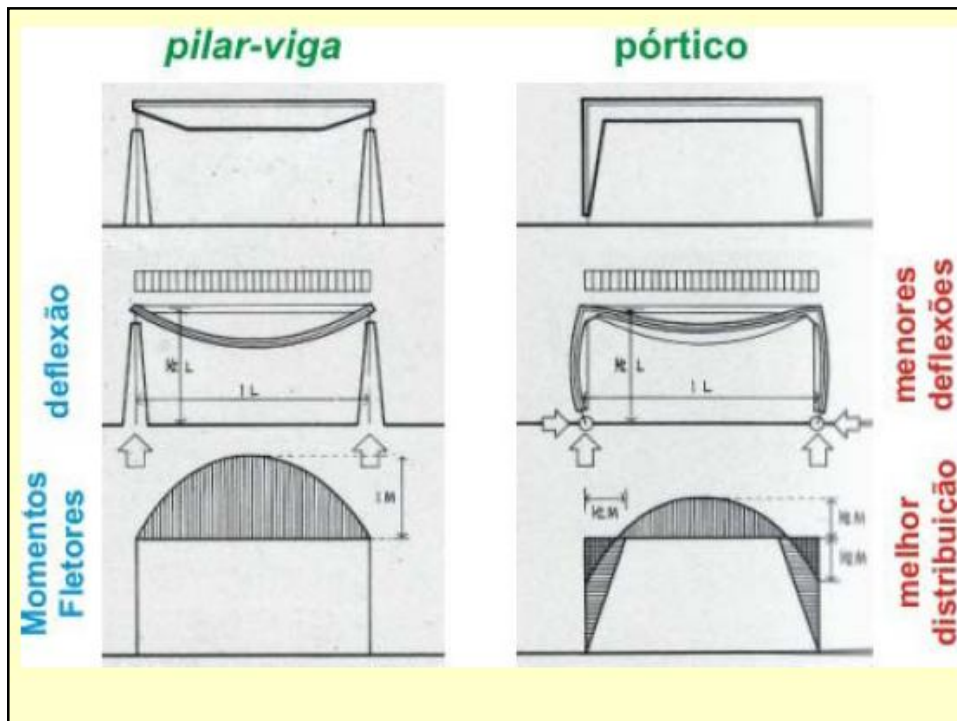
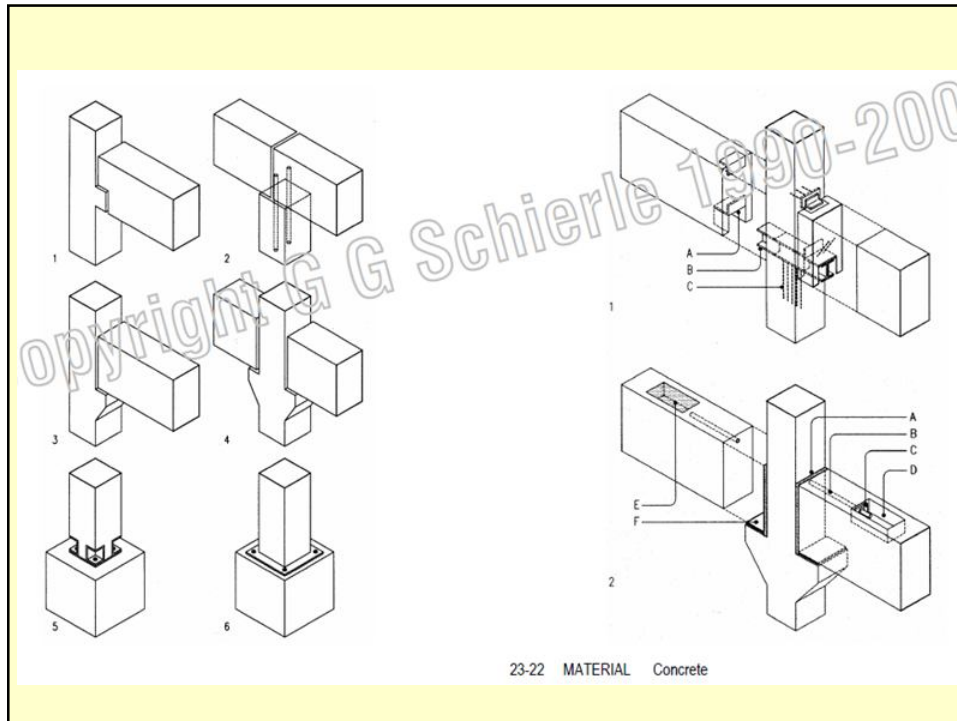

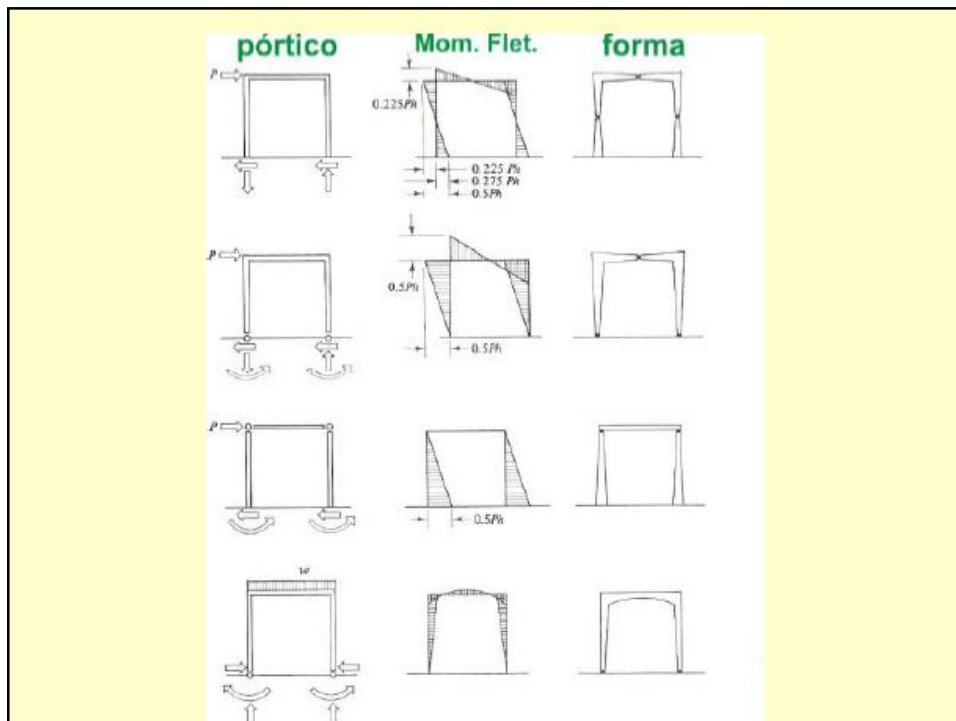
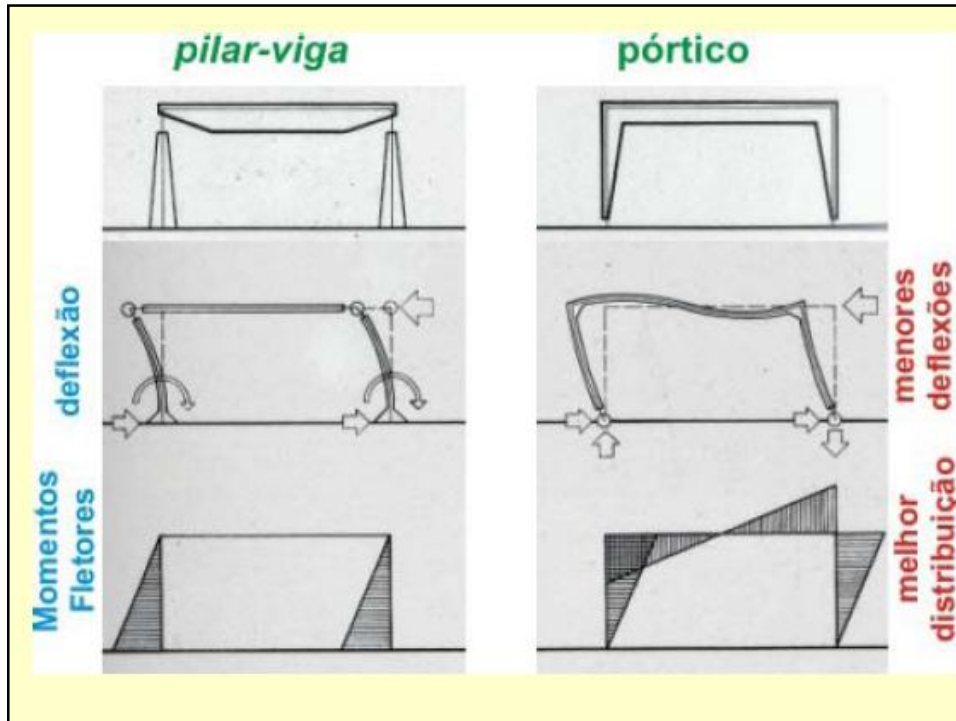

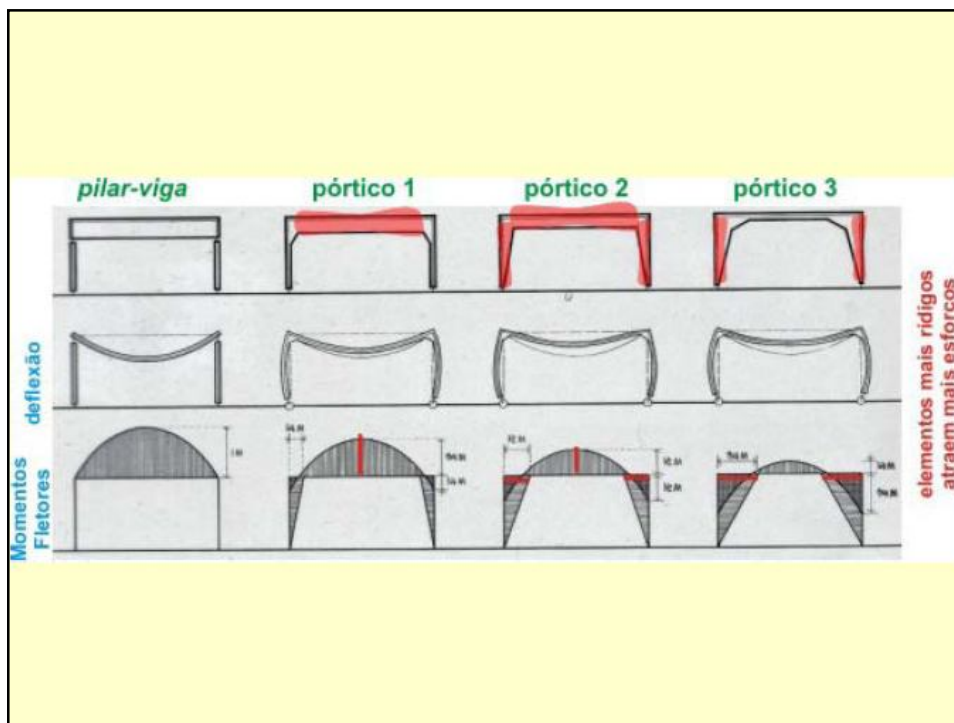

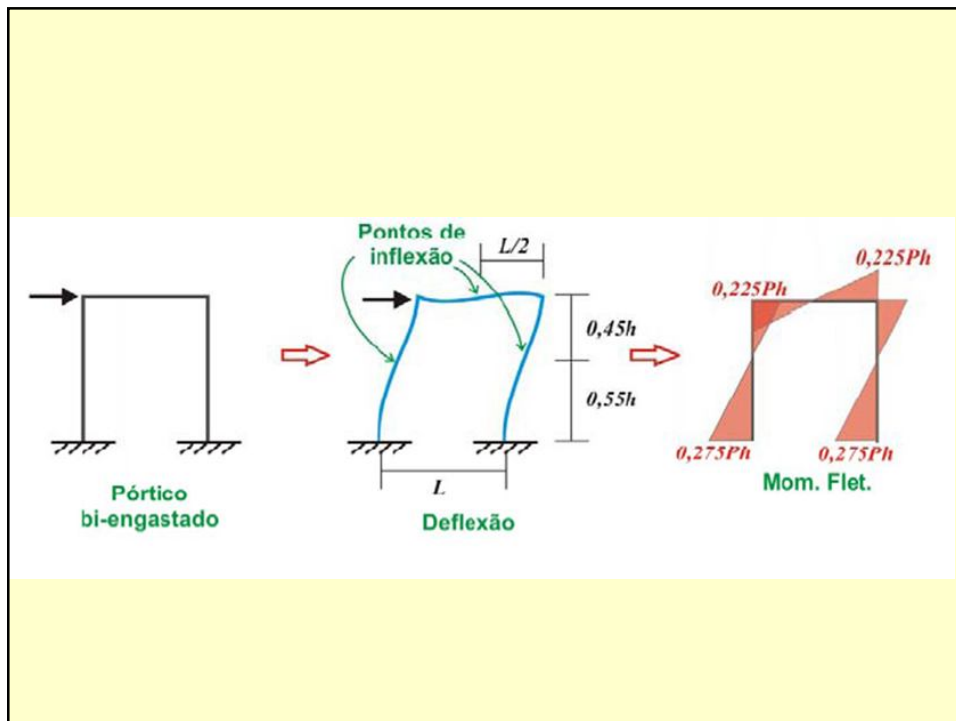
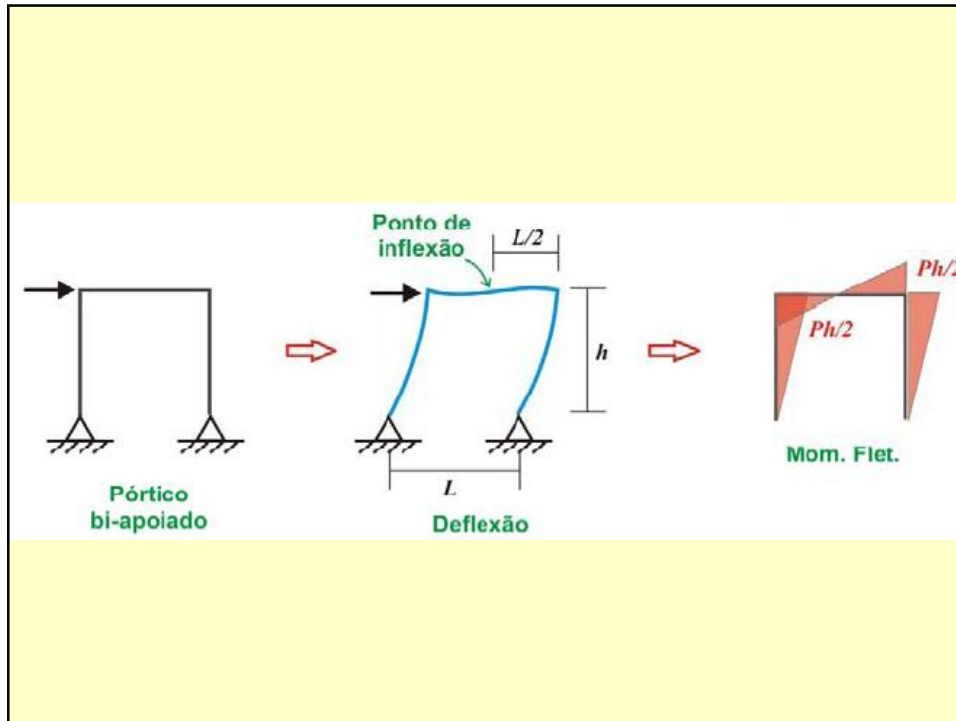

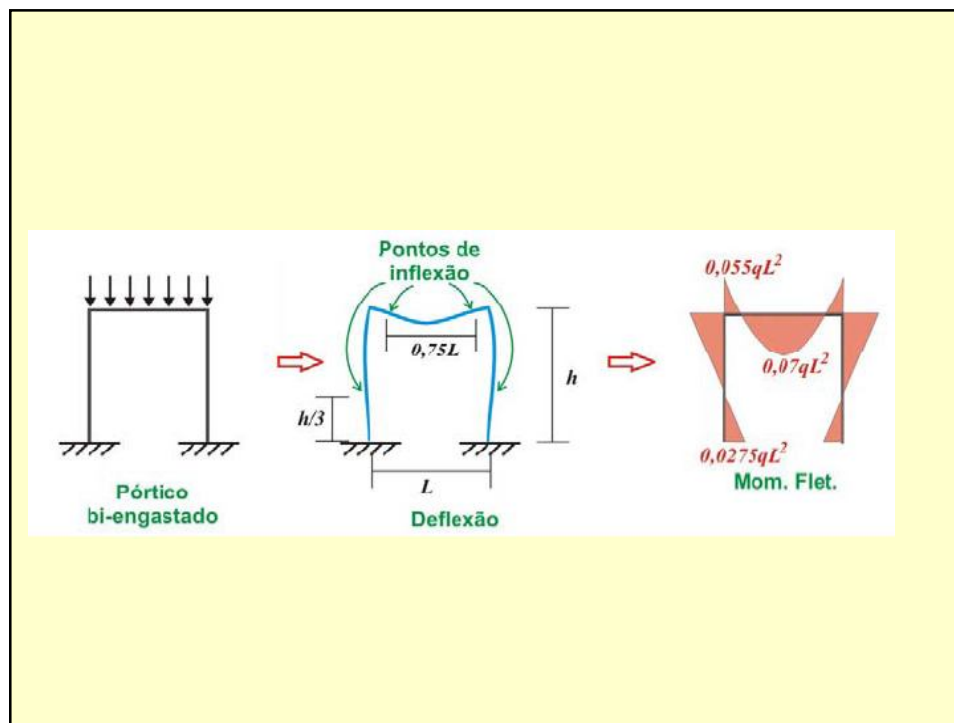
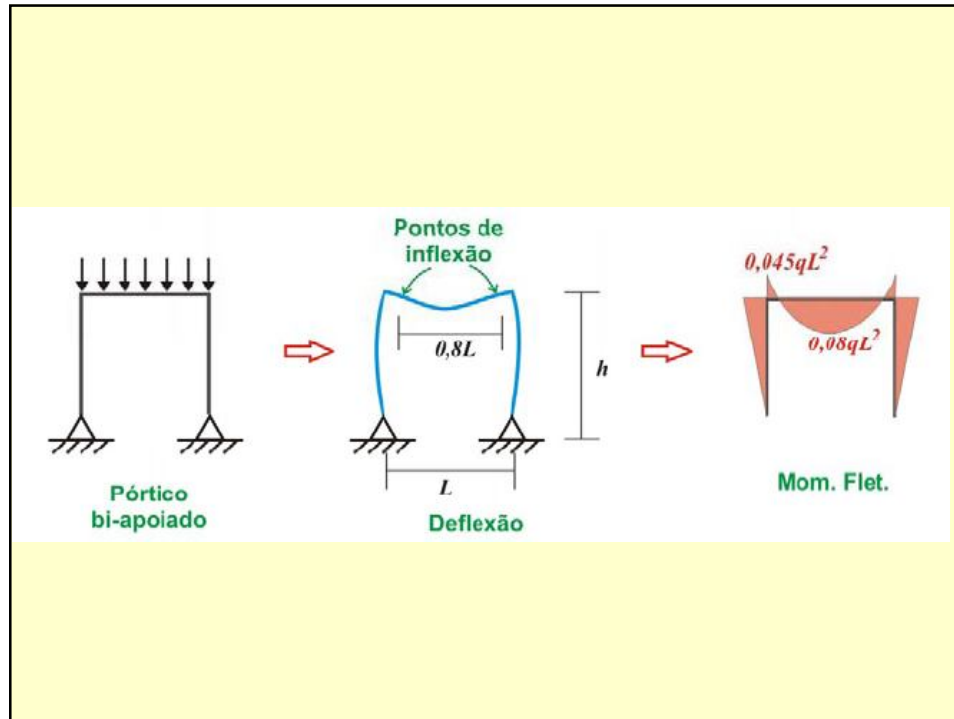

⇒ **Aplicação: pré-moldados**

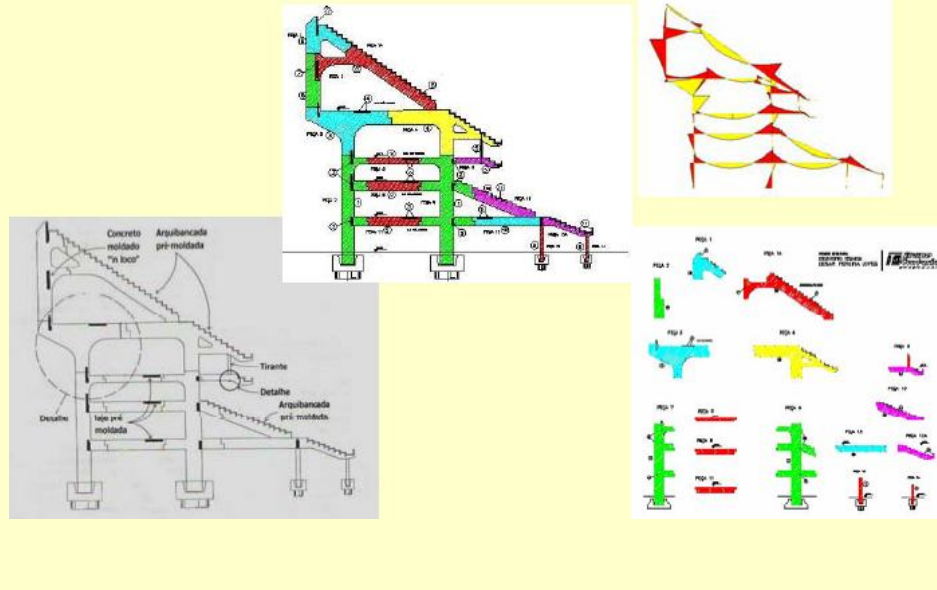

• **Painéis Vierendeel**

⇒ **estrutura horizontal**

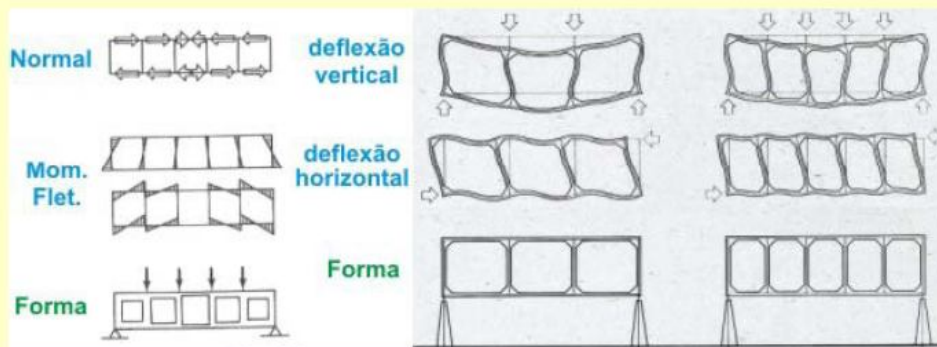

Edifícios altos – instabilidade estrutural

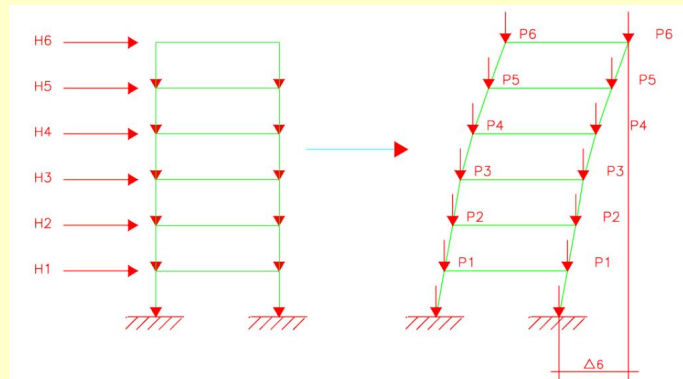

20 pavimentos

30 pavimentos

40 pavimentos

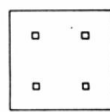
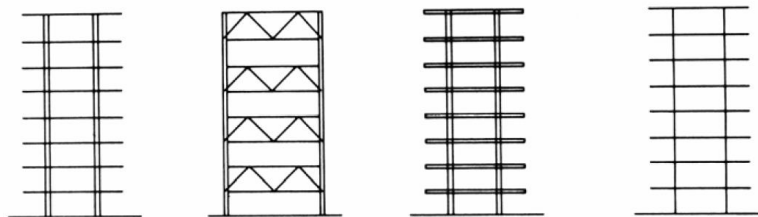

Pilares

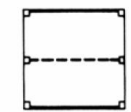

Treliça Inter Pavimento

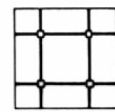

Pórticos

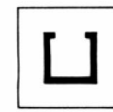

Núcleos

Giongo, 2006

