

The Handbook of
**Historical
Linguistics**

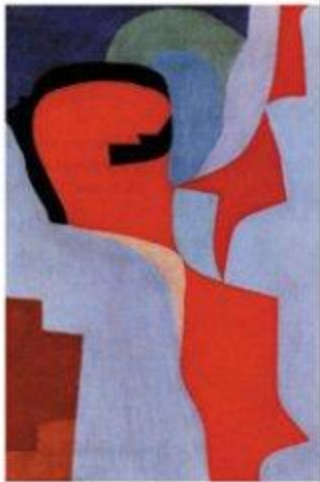

Edited by

**Brian D. Joseph
and Richard D. Janda**



The Handbook of Historical Linguistics

Blackwell Handbooks in Linguistics

This outstanding multi-volume series covers all the major subdisciplines within linguistics today and, when complete, will offer a comprehensive survey of linguistics as a whole.

Already published:

The Handbook of Child Language

Edited by Paul Fletcher and Brian MacWhinney

The Handbook of Phonological Theory

Edited by John A. Goldsmith

The Handbook of Contemporary Semantic Theory

Edited by Shalom Lappin

The Handbook of Sociolinguistics

Edited by Florian Coulmas

The Handbook of Phonetic Sciences

Edited by William J. Hardcastle and John Laver

The Handbook of Morphology

Edited by Andrew Spencer and Arnold Zwicky

The Handbook of Japanese Linguistics

Edited by Natsuko Tsujimura

The Handbook of Linguistics

Edited by Mark Aronoff and Janie Rees-Miller

The Handbook of Contemporary Syntactic Theory

Edited by Mark Baltin and Chris Collins

The Handbook of Discourse Analysis

Edited by Deborah Schiffrin, Deborah Tannen, and Heidi E. Hamilton

The Handbook of Language Variation and Change

Edited by J. K. Chambers, Peter Trudgill, and Natalie Schilling-Estes

The Handbook of Historical Linguistics

Edited by Brian D. Joseph and Richard D. Janda

The Handbook of Language and Gender

Edited by Janet Holmes and Miriam Meyerhoff

The Handbook of Second Language Acquisition

Edited by Catherine Doughty and Michael H. Long

The Handbook of Historical Linguistics

Edited by

*Brian D. Joseph and
Richard D. Janda*

© 2003 by Blackwell Publishing Ltd

350 Main Street, Malden, MA 02148-5018, USA
108 Cowley Road, Oxford OX4 1JF, UK
550 Swanston Street, Carlton South, Melbourne, Victoria 3053, Australia
Kurfürstendamm 57, 10707 Berlin, Germany

The right of Brian D. Joseph and Richard D. Janda to be identified as the Authors of the Editorial Material in this Work has been asserted in accordance with the UK Copyright, Designs, and Patents Act 1988.

All rights reserved. No part of this publication may be reproduced, stored in a retrieval system, or transmitted, in any form or by any means, electronic, mechanical, photocopying, recording or otherwise, except as permitted by the UK Copyright, Designs, and Patents Act 1988, without the prior permission of the publisher.

First published 2003 by Blackwell Publishing Ltd

Library of Congress Cataloging-in-Publication Data

The handbook of historical linguistics / edited by Brian D. Joseph and Richard D. Janda.
p. cm. – (Blackwell handbooks in linguistics)

Includes bibliographical references and index.

ISBN 0-631-19571-8 (alk. paper)

1. Historical linguistics. I. Joseph, Brian D. II. Janda, Richard D. III. Series.

P140 .H35 2003
417'.7–dc21

2002074363

A catalogue record for this title is available from the British Library.

Set in 10/12pt Palatino
by Graphicraft Limited, Hong Kong
Printed and bound in the United Kingdom
by T.J. International, Padstow, Cornwall

For further information on
Blackwell Publishing, visit our website:
<http://www.blackwellpublishing.com>

Some images in the original version of this book are not available for inclusion in the eBook.

Contents

List of Contributors	ix
Preface	xi
Part I Introduction	1
On Language, Change, and Language Change – Or, Of History, Linguistics, and Historical Linguistics	3
RICHARD D. JANDA AND BRIAN D. JOSEPH	
Part II Methods for Studying Language Change	181
1 The Comparative Method	183
ROBERT L. RANKIN	
2 On the Limits of the Comparative Method	213
S. P. HARRISON	
3 Internal Reconstruction	244
DON RINGE	
4 How to Show Languages are Related: Methods for Distant Genetic Relationship	262
LYLE CAMPBELL	
5 Diversity and Stability in Language	283
JOHANNA NICHOLS	
Part III Phonological Change	311
6 The Phonological Basis of Sound Change	313
PAUL KIPARSKY	
7 Neogrammarian Sound Change	343
MARK HALE	
8 Variationist Approaches to Phonological Change	369
GREGORY R. GUY	

9	“Phonologization” as the Start of Dephonetization – Or, On Sound Change and its Aftermath: Of Extension, Generalization, Lexicalization, and Morphologization RICHARD D. JANDA	401
Part IV Morphological and Lexical Change		423
10	Analogy: The Warp and Woof of Cognition RAIMO ANTILA	425
11	Analogical Change HANS HENRICH HOCK	441
12	Naturalness and Morphological Change WOLFGANG U. DRESSLER	461
13	Morphologization from Syntax BRIAN D. JOSEPH	472
Part V Syntactic Change		493
14	Grammatical Approaches to Syntactic Change DAVID LIGHTFOOT	495
15	Variationist Approaches to Syntactic Change SUSAN PINTZUK	509
16	Cross-Linguistic Perspectives on Syntactic Change ALICE C. HARRIS	529
17	Functional Perspectives on Syntactic Change MARIANNE MITHUN	552
Part VI Pragmatico-Semantic Change		573
18	Grammaticalization BERND HEINE	575
19	Mechanisms of Change in Grammaticization: The Role of Frequency JOAN BYBEE	602
20	Constructions in Grammaticalization ELIZABETH CLOSS TRAUOGOTT	624
21	An Approach to Semantic Change BENJAMIN W. FORTSON IV	648
Part VII Explaining Linguistic Change		667
22	Phonetics and Historical Phonology JOHN J. OHALA	669
23	Contact as a Source of Language Change SARAH GREY THOMASON	687
24	Dialectology and Linguistic Diffusion WALT WOLFRAM AND NATALIE SCHILLING-ESTES	713

25	Psycholinguistic Perspectives on Language Change	736
	JEAN AITCHISON	
	Bibliography	744
	Subject Index	843
	Name Index	856
	Language Index	879

*I think we agree: the past is over.**

George W. Bush, May 10, 2000 (quoted in the *Dallas Morning News*)

[W]ho can produce a book entirely free of mistakes?

Theodosius Grigorievich Dobzhansky, 1970

* Here, "we" = (i) Bush, then governor of Texas, and (ii) John McCain, US Senator from Arizona and formerly Bush's main competitor in the Republican primary elections preceding his successful campaign for the US presidency.

Contributors

JEAN AITCHISON

Worcester College, University of Oxford, UK

RAIMO ANTILA

Department of Linguistics, University of California at Los Angeles, USA

JOAN BYBEE

Department of Linguistics, University of New Mexico, USA

LYLE CAMPBELL

Department of Linguistics, University of Canterbury, New Zealand

WOLFGANG U. DRESSLER

Institut für Sprachwissenschaft, Universität Wien, Austria

BENJAMIN W. FORTSON IV

Houghton Mifflin Company, Boston, MA, USA

GREGORY R. GUY

Department of Linguistics, New York University, USA

MARK HALE

Department of Classics, Concordia University, Canada

ALICE C. HARRIS

Program in Linguistics, Vanderbilt University, USA, and Department of Linguistics, University at Stony Brook-SUNY, USA

S. P. HARRISON

Department of Anthropology, University of Western Australia, Australia

BERND HEINE

Institut für Afrikanistik, Universität zu Köln, Germany

HANS HENRICH HOCK

Department of Linguistics, University of Illinois, USA

RICHARD D. JANDA

Department of Linguistics, The Ohio State University, USA

BRIAN D. JOSEPH

Department of Linguistics, The Ohio State University, USA

PAUL KIPARSKY

Department of Linguistics, Stanford University, USA

DAVID LIGHTFOOT

Department of Linguistics, Georgetown University, USA

MARIANNE MITHUN

Department of Linguistics, University of California at Santa Barbara, USA

JOHANNA NICHOLS

Department of Linguistics, University of California, Berkeley, USA

JOHN J. OHALA

Department of Linguistics, University of California, Berkeley, USA

SUSAN PINTZUK

Department of Language and Linguistic Science, University of York, UK

ROBERT L. RANKIN

Department of Linguistics, University of Kansas, USA

DON RINGE

Department of Linguistics, University of Pennsylvania, USA

NATALIE SCHILLING-ESTES

Department of Linguistics, Georgetown University, USA

SARAH GREY THOMASON

Department of Linguistics, University of Michigan, USA

ELIZABETH CLOSS TRAUOGT

Department of Linguistics, Stanford University, USA

WALT WOLFRAM

Department of English, North Carolina State University, USA

Preface

Any large-scale work like this typically involves a huge amount of effort on the part of a great many individuals, and such is certainly the case with the present volume. Given the enormous debt of gratitude owed by the editors to all the participants in this massive project, we are moved to adopt (and adapt) the phrasing which Peter Schickele (1976: xvii) was led to use in expressing his thanks for the help he had received with one of his books (though of a very different nature):

A project of this scope could not be realized without the aid of many people . . . [–] or rather it *could*, but it would be dumb to do it that way when there are so many people around willing to give their aid. It is impossible to thank by name every single person who helped . . . , but it would be a . . . shame if . . . [the editors] didn't mention those to whom . . . [they are] most deeply indebted.

Most importantly, the authors represented here have all been very cooperative and, on the whole, quite prompt. Inasmuch as this work has developed over a long period of time – the initial proposal for the volume was first put together in 1994 – we especially thank all parties involved for their indulgence and patience at moments when the book occasionally seemed to be barely inching its way toward the finish line. To a great extent, the single longest delay resulted from our working through several conceptions of our introductory chapter, which we finally came to see not as a mere curtain-raiser to open the volume, but as an attempt to wrestle with significant but rarely addressed questions concerning the general nature of historical linguistics, even if this extended the work's gestation period beyond what any of us originally expected or could easily have imagined.

Still, even with the passage of so much time – or even precisely because of it – we are encouraged by the following apposite words (brought to our attention by William Clausing) from Nietzsche's 1886 book *Morgenröte: Gedanken über die moralischen Vorurteile* (“*Daybreak: Thoughts on the Prejudices of Morality*”),

which we here give after an excerpt (p. 5) from the 1997 translation by R. J. Hollindale (edited by Maudemarie Clark and Brian Leiter):¹

Above all, let us say it SLOWLY. . . . This preface is late, but not too late . . . – what, after all, do five or six years matter? A book like this, a problem like this, is in no hurry; we both, . . . just as much as . . . [the] book, are friends of *lento*. It is not for nothing that one has been a philologist; perhaps one is a philologist still – that is to say, a teacher of slow reading; in the end, one also writes slowly . . . [P]atient friends, this book desires for itself only perfect readers and philologists[; it asks]: learn to read me well!

Whether just understandably human or else all too human in explanation, the lengthy preparation-time expended on this volume makes it hard for us to list exhaustively all the input and assistance that have gone into making the final product what it is. Still, we would like to single out by name a number of people and institutions for special thanks. Most of all, we gratefully acknowledge the support of our respective families and relatives, the sore trying of whose patience must sometimes have led them to wonder whether our jobs required them to be Jobs. We are also extremely appreciative of the help provided over the years by several research assistants, especially Toby Gonsalves, Steve Burgin, Mike Daniels, and Pauline Welby. To the staff at Blackwell Publishing, particularly Beth Remmes and Tami Kaplan, we are forever indebted for their unusual tolerance of our persistent tinkering, their willingness to accommodate their schedules to our work habits, and their enthusiasm for the project in the first place (from the earliest moments of Philip Carpenter's first conversations with us through Steve Smith's encouragement along the way). Finally, we thank the Department of Linguistics, along with the Department of Slavic and East European Languages and Literatures, both at The Ohio State University, for providing significant support in the form of subsidies for postage and xeroxing, computer accounts, and access to research assistants.

It is traditional to offer a dedication for a book; how could a volume on historical linguistics not embrace such a tradition wholeheartedly? Since a dedication to our families could not even begin to express adequately our appreciation for their long suffering through seemingly endless discussions of individual chapters and related issues, followed by the thrashing out of draft after draft of the introduction, we promise them other compensation for their sacrifices. Hence we must turn elsewhere for an appropriate object of our dedication – though not completely.

In a sense, virtually all our efforts in editing this handbook have confronted us with the inescapable fact that the best work in linguistic diachrony nearly always involves various sorts of collaboration – collaboration that is at times even family-like (parental or filial, between teachers and students; fraternal or sororal, among colleagues and competitors), but more often just amicable, and almost invariably cooperative in several senses. For example, in cases where investigators of language change express violent disagreement with

their predecessors, a closer look tends to reveal that a strong rebuttal of an earlier position may still crucially presuppose some determinative phrasing of scholarly questions, an indispensable collation of the facts, or pioneering paleographic spadework by the previous researcher being criticized. Just as often, advances in historical linguistics arise via the progressive, mosaic-like accumulation of contributions that gradually come to cover all relevant aspects of, and perspectives on, a particular diachronic problem. Increasingly, too, breakthroughs in various specializations have brought such complexity to linguistic diachrony as a whole that a single person cannot gain or maintain expertise in all of its subfields, and therefore a collaborative approach becomes inescapable. In all of these instances, scholarly cooperation and collectivity really do provide demonstrable benefits for individuals, since they allow the weaknesses of one researcher to be compensated for by the strengths of another. After all, as the author of the Argentine gaucho epic *Martín Fierro* put matters (albeit within a very different context) – cf. Hernández (1872: 33, lines 1057–8; our translation): “It’s not unusual for one person to be short of something that another person has more than enough of.”²

One aspect of collaboration has to do, of course, with interdisciplinary research. A solid beginning in this direction already exists in the many writings which compare diachronic or synchronic linguistics with biology (especially its evolutionary aspects) and paleontology. In a field which calls itself “historical linguistics,” focusing on change over time, one might also expect to encounter substantial cross-contacts in which (diachronic) linguists react to the work of historians and other students of time and change – especially philosophers, but also anthropologists, psychologists, and physicists. In preparing our introductory chapter, though, we were surprised to find so few recent discussions by linguistic diachronicians of intersections between our field and the work of historians or other specialists on time and change. The extensive scope of our introductory essay is therefore due in large part to our having attempted to discuss a judicious selection of directly relevant historical and time- or change-related work. Since we are not specialists in those fields, our remarks concerning them should be taken as suggestive leads intended to goad our readers into joining us in exploring links with those other disciplines. Their doing so will promote collaboration more than sufficient to make up for any castigation we may receive at the hands of those with greater sophistication in the above-mentioned fields.

At this juncture, however, we can probably best promote interdisciplinary approaches to language change by acknowledging briefly, with admiration and astonishment, the standard set for linguists by those (non-linguistic) historians who sift through what seem like not only mountains but even mountain ranges of written and other evidence in their studies of earlier times. We have in mind here, besides a number of studies mentioned in our introductory chapter, such volumes as Gerhard L. Weinberg’s meticulously documented *The Foreign Policy of Hitler’s Germany* (1970–80) and his even more comprehensive *A World at Arms: A Global History of World War II* (1994), or David Hackett Fischer’s

Albion's Seed: Four British Folkways in America (1989) – as broad as it is deep – and his more specialized *Paul Revere's Ride* (1994). Thus, for example, though Fischer (1994) focuses on a subject which might seem already to have been strip-mined to oblivion by earlier historians, he succeeds in reaching original conclusions by basing its 17 chapters of connected narrative and analysis (pp. 1–295) on 124 pages of documentation, the latter including 19 appendices (pp. 297–325), 12 historiographical summaries (pp. 327–44), 46 categories of primary-source listings (pp. 345–72, with an overview on p. 345), and 841 notes (pp. 373–421). Even more exemplary is the documentation in Weinberg (1994b) – more than 3,000 notes (of two sorts, filling over 180 pages), supplemented by 23 maps and a 24-page bibliographical essay on the variety of published and archival sources consulted (the major abbreviations alone taking three pages to list) – given that its wealth of unpublished material allows Weinberg to establish multiple points of detailed fact which in turn justify more global conclusions of great novelty and insight.³ In the presence of such scholarship, we do not see how any historically minded researcher could react otherwise than as Beethoven said he would do (here in our retranslation; cf. Thayer et al. 1908: 455–8 on the tangled transmission of the composer's remarks) in expressing his esteem for Handel: "I would bare my head and fall to my knees!"⁴

Still, regardless of the degree to which they do or do not individually cross inter- or intra-disciplinary boundaries, we are convinced that the chapters of this volume together demonstrate the value, utility, and necessity of collaboration in work on language change: no single author, living or dead, could possess the expertise in all branches of historical linguistics needed in order to author alone a handbook like this. Similarly, the combination of planning, advisory commenting, and introduction-writing carried out by the editors has been possible only through a highly collaborative effort. And sometimes even the names of collaborating authors and/or editors can undergo a kind of fusion. In a number of our own joint works (supplementary to our independent writings), although all of these have been produced via absolutely equal participation, there have even occasionally been variations in the ordering of our names (a case in point being that for the editorship of this handbook as a whole versus that for the authorship of this preface and the introduction). Such variable orderings have caused bibliographical conundrums occasionally finessed by references to "J and J."

Now, in all humility, we readily admit that we are not now, nor are we ever likely to be, the best-known – and we certainly are not the first – J and J to collaborate in historical linguistics. Rather, both of these distinctions seem likely to be held in perpetuity by Karl Jaberg (1877–1958) and Jakob Jud (1882–1952); cf., for example, Bronstein et al. (1977: 102–3, 111–12). Besides publishing many individual works, these two giants of Romance dialectology and its diachronic implications co-authored the monumental *Sprach- und Sachatlas Italiens und der Südschweiz* (1928–40); this "*Linguistic and Material Atlas of Italy and Southern Switzerland*" consists of eight primary volumes, plus three

supplemental ones, and it contains more than 1,700 maps. (It in turn served as the main model for the *Linguistic Atlas of New England* (Kurath et al. 1939–43), whose staff Jud helped to train.) Most importantly, though, the joint productions of this earlier J-and-J pair provide exactly the model for linguistic diachronicians' (and variationists') collaboration to which we aspire and which we so highly recommend; cf. Malkiel (1959: 259):

[T]he two Swiss scholars were . . . different in temperaments, tastes, and ambitions. It was their ability to bridge this . . . discernible gap in embarking on a joint venture, with thorough mutual respect for . . . [each other's] accomplishments and inclinations, that assured the[ir] . . . success. . . . Jaberg . . . and Jud exemplify a team who succeeded in maintaining their bonds of loyalty . . . through different stages of their . . . lives, despite . . . occasional disagreements on matters of detail. No severer test of a person's tact and delicacy has ever been devised.

While Jaberg and Jud had the luxury of frequently conferring in person as they carried out their joint work on dialectology and diachrony, the field of historical linguistics – especially, again, historical Romance linguistics – provides several equally encouraging instances of long-distance collaboration (a difficult circumstance of which we two have become acutely aware while finishing the joint editing of this volume via messages, phone calls, and mailings back and forth across the Atlantic).

One of the most inspiring such examples involves the international exchange of scholarly papers and epistolary consultations between a German-born Austrian and a Spaniard who, despite their very different backgrounds, circumstances, and ages, remained in touch as they each matched their long lifetimes with publication lists characterized by not only length but also longevity (i.e., active shelf-lives). Given that mail delivery by train between major European cities – especially before the rise of air transport during and following World War II – was once astoundingly rapid (even by today's standards), a question/answer pair of messages traveling by rail from Graz to Madrid and back could be exchanged faster than many twenty-first-century scholars read and answer their e-mail via the Internet. Thus, in the decades straddling the turn from the nineteenth to the twentieth century, it often took only two days for a letter from Hugo (Ernst Maria) Schuchardt (1842–1927) to reach Ramón Menéndez Pidal (1869–1968) when they were corresponding about their prolific contributions to so many fields. Schuchardt wrote on Romance dialects and Vulgar Latin, but also more generally; he specialized in analogy, etymology, and sound-“laws” – regarding the last of which he took on the Neogrammarians, as in his 1885 *Über die Lautgesetze: gegen die Junggrammatiker* – and he was an initiator of creole and language-contact studies (cf. Baggioni 1996). Menéndez Pidal, too, was a dialectologist, but he is best known for founding historical philology in Spain through his tireless activities in editing medieval texts, developing (from 1904 through its twelfth edition in 1966) an increasingly detailed *Manual de gramática histórica española* (“*Handbook of Spanish Historical Grammar*”), publishing

on stylistics, founding a journal, training students, and presiding for more than thirty years over the Royal Spanish Academy (cf. Portolés 1996).

The poignant culmination of the mutually supportive communications between Schuchardt and Menéndez Pidal arguably came when the Austrian, in his early eighties, was asked to contribute an original study as a collegial offering for the festschrift (three volumes, later published as Comisión organizadora 1925) then being prepared in honor of his Spanish correspondent. Schuchardt responded with a poem explaining that, although his arms were too weak to carry the heavy dictionaries needed for a work of scholarship, and his eyes too tired to read the tiny print of their contents, he could still send a simple greeting in verse to the man who had edited – and done so much else to promote the study of – the twelfth-century Spanish epic “*El cantar de mío Cid*” (“The Song of My Cid”), itself a poem celebrating Rodrigo Díaz de Vivar (c.1043–99), the noble warrior-champion (in older Spanish, *campeador*) who had become known as *el Cid* (from Spanish Arabic *as-sīd* “the lord”). In his boyhood, wrote Schuchardt (1925), the story of *el Cid* had provided him with a radiant paragon of heroism to whom he dedicated childish verses. But then Ramón Menéndez Pidal’s editions of that epic narrative had firmly linked the fame of Don Rodrigo with the name of the poem’s energetic and academically fearless editor – Don Ramón – thus again justifying use of a salutation from long ago to address a warrior-champion of philology: “*Mío Cid Campeador*.” In light of such a magnanimous gesture, it is our wish that every historical linguist should be able to correspond, and even to collaborate, with an altruistic, truly encouraging colleague of this sort.⁵

We are hopeful, then, that these kinds of productive close cooperation among investigators of language change will turn out to be at least as common and as fruitful later in the new century and millennium as they are now, and as they were in previous centuries. Such a pooling of strengths and resources is dictated not only by the above-mentioned growing complexity of differing specializations within research on linguistic diachrony, but also by the fact that – as our introductory chapter emphasizes in several places (especially its concluding sections) – a sharing of labor between studies of changes completed in the past and studies of ongoing changes in the present seems likely to provide the surest basis for progress in our field. And these dual foci of attention virtually demand a maximum of coordinated joint work – of collaboration.

We therefore dedicate this book to the spirit of cooperation and collaboration in historical linguistics – past, present, and future. This attitude is embodied (if not directly expressed) by the following anonymous poem in Sanskrit, the language whose growing importance in late-eighteenth-century and early-nineteenth-century philology is generally viewed as having provided perhaps the major impetus for the ensuing development of historical linguistics into a science. The verses in question were anthologized by Böhtlingk (1870: 175) as no. 940 (no. 346 in his earlier, shorter edition); we present them first in devanagari script and then in transliteration, followed by our more metrical and referentially broader adaptation of the translation by Brough (1968: 69; his

no. 62).⁶ We know of no more eloquent way to symbolize the interconnectedness of (i) time and history, (ii) scholarship via friendly collaboration, and – by implication – (iii) language:

अदौ तन्व्यो बृहन्मध्या विस्तारिण्यः पदे पदे ।
यायिन्यो न निवर्तन्ते सतां मैत्र्यः सरित्समाः ॥

ādāu tanvyo bṛhanmadhyā vistāriṇyaḥ pade pade
yāyinyo na nivartante satām māitryaḥ saritsamāḥ

Quite lean at first, they quickly gather force, And grow in
richness as they run their course;
Once started, back again they do not bend: Great rivers,
years, and ties to a good friend.

Richard D. Janda
The American Library in Paris

Brian D. Joseph
Columbus, Ohio

NOTES

- 1 Nietzsche's (1881/1964: 9–10) original German reads: "– . . . Vor allem sagen wir es langsam. . . . Diese Vorrede kommt spät, aber nicht zu spät . . . [.] was liegt im Grunde an fünf, sechs Jahren? Ein solches Buch, ein solches Problem hat keine Eile; überdies sind wir beide Freunde des *lento*, . . . ebensowohl als . . . [das] Buch. Man ist nicht umsonst Philologe gewesen, man ist es vielleicht noch . . . [–] das will sagen, ein Lehrer des langsamen Lesens: endlich schreibt man auch langsam . . . [G]eduldige . . . Freunde, dies Buch wünscht sich nur vollkommene Leser und Philologen[; es bittet]; lernt mich gut lesen!! –."
- 2 The original Spanish of Hernández' gaucho narrator (1872: 33) states: "No es raro que a uno le falte / lo que [a] algún otro le sobre."
- 3 Weinberg (1994) is unique in combining presentation of details like Hitler's 1940 order to ready plans for invading Switzerland – a project, "[o]riginally code-named operation 'Green', renamed 'Christmas Tree' when the former . . . was applied to the planned invasion of Ireland" (pp. 174, 982nn.219–23) – with discussion of such higher-level conclusions as the tactical failure (and not just the strategic error) of Pearl Harbor's bombing: "The ships were for the most part raised; by the end of December . . . [, 1941,] two of the battleships . . . imagined sunk were on their way to the West Coast for repairs . . . [, and ultimately a]ll but the *Arizona* returned to service" (pp. 258–62, 1004–5nn.338–57). The story- and script-writers of the 2001 film *Pearl Harbor* should have read Weinberg (1994) first.
- 4 Thayer et al. (1908: 455–8) give the German version of what Beethoven said as: "Ich würde mein Haupt entblößen und . . . niederknien!"

- 5 Schuchardt's (1925) original German is as follows: "Einst, in meinen Kinderjahren . . . [,] / Strahlte mir der Cid als Vorbild / Wahren Heldentums entgegen, / Und ich weiht' ihm kind'sche Verse. . . . / Mit dem Ruhm von Don Rodrigo / Habt Ihr, Don Ramón, den Euern / Fest verknüpft. . . . / . . . Nun . . . / steigt wie einst der Gruß empor: / *Mío Cid Campeador*." For the previously mentioned information about the speed of early twentieth-century mail delivery by train between Austria and Spain, we are indebted to Bernhard Hurch, who now holds Schuchardt's chair at the University of Graz (where there is a Schuchardt archive which maintains a site on the World-Wide Web).
- 6 In contrast to the preceding endnoted remarks, we should inform our readers that (with rare exceptions) no original non-English versions are given for any of the quotations included in the following introductory discussion of the topics and contents found in this volume. This decision to use only translations (which are uniformly our own, if not otherwise attributed) in the general introduction to the book reflects not our preferences, but the need to achieve at least some economies of space in an already lengthy essay.

Part I

Introduction

Introduction Contents

1 Part the First: Intersections of Language and History in this Handbook	4
1.1 On language – viewed synchronically as well as diachronically	4
1.1.1 <i>The nature of an entity largely determines how it can change</i>	4
1.1.2 <i>Pruning back the view that languages change like living organisms</i>	6
1.2 On change – both linguistic and otherwise	10
1.2.1 <i>Lesser and greater ravages of time</i>	11
1.2.2 <i>Uniformitarianism(s) versus uninformed tarryin' -isms</i>	23
1.2.3 <i>Change revisited</i>	38
1.3 On time	89
1.3.1 <i>A skeptical challenge to the unreconstructed nature of reconstructions</i>	93
1.3.2 <i>Time is not space (and diachrony is not diatopy) – but is time travelable?</i>	95
1.3.3 <i>Whence reconstruction?</i>	102
2 Part the Second: Historical Aspects of the Linguistics in this Handbook	114
2.1 Reconstructing from absences – or, topics to be found elsewhere	115
2.2 Constructing a present – or, topics to be found here	119
2.3 Synthesizing tradition and innovation – or, topics here in a new light	125
3 Epilogue and Prologue	127
3.1 Passing on the baton of language – and of historical linguistics	127
3.2 Envoi	130
Notes	131

On Language, Change, and Language Change – Or, Of History, Linguistics, and Historical Linguistics

RICHARD D. JANDA AND BRIAN D. JOSEPH

Fellow-citizens, we can not escape history.

Abraham Lincoln, “[2nd] Annual Message of the President of the U.S. to the Two Houses of Congress; December 1, 1862” original emphasis, reprinted in Richardson (1897: 142)

*History is more or less bunk.*¹

Henry Ford as interviewed by Charles N. Wheeler; *Chicago Daily Tribune* 75.125 (May 25, 1916: 10) (repeated under oath during Ford’s libel suit against the *Tribune* before a court in Mount Clemens, Michigan (July, 1919))

In this introduction to the entire present volume – a collection of chapters by scholars with expertise in subareas of historical linguistics that together serve to define the field – we seek to accomplish three goals. First, we present and explicate what we believe to be a particularly revealing and useful perspective on the nature of language, the nature of change, and the nature of language change; in so doing, we necessarily cover some key issues in a rather abbreviated fashion, mainly identifying them so that they may together serve as a frame encompassing the various subsequent chapters. Second, we introduce the book itself, since we feel that in many respects this volume is unique in the field of linguistic diachrony. Third and finally, we seize the opportunity provided by the still relatively recent turn of both the century and the millennium to step back for a moment, as it were, and use the image of historical linguistics that emerges from the representative set of papers in this handbook for the purpose of reflecting on what the present and future trajectory of work in our field may – and can – be.

Thus, in the first part of this introduction, we do not hesitate to address extremely general, even philosophical, issues concerning language, change, and language change – whereas, in its second part, we focus on more concrete matters pertaining to the volume at hand, and, in its third part, we present a modest, minimal synthesis that aims to assess what are likely to be the most promising avenues and strategies for investigation as research on linguistic change continues to move forward to (the study of) the past. As we pursue these three goals, we intentionally do not at any point give chapter-by-chapter summaries. Rather, we weave in references to chapters as we discuss major issues in the field, with references to the authors here represented given in SMALL CAPITALS when they occur.

The particular thematic organization of our discussion, however, does not alter the fact that the major sections into which this book is divided follow fairly traditional – and thus for the most part familiar – lines of division: the twenty-five chapters that follow are grouped into sections in such a way as to fall into three main parts. First, in part II, the major methodologies employed in studying language change are presented, with emphasis on the tried-and-true triad of the comparative method, internal reconstruction, and (the determination of) genetic relatedness. Second, in parts III through VI, discussions of change in different domains and subdomains of grammar are to be found: these respectively cover phonology, morphology/lexicon, syntax, and pragmatics/semantics, in that order. In each case, the topics are approached from two or more different – and sometimes even opposing – perspectives. Third, in part VII, various causes of change, both internal and external – and cognitive as well as physiological – share the spotlight. In all of these sections, the long tradition of scholarship in historical linguistics in general is amply represented, but a final indication of the dimensions of the scholarly tradition in these areas can be found in this volume’s composite bibliography, which collects all the references from all the chapters and this introduction into a single – and massive – whole.

1 Part the First: Intersections of Language and History in this Handbook

1.1 *On language – viewed synchronically as well as diachronically*

1.1.1 *The nature of an entity largely determines how it can change*

[A] language . . . is a grammatical system existing . . . in the brains of a group of individuals . . . [;] it exists perfectly only in the collectivity . . . , external to the individual.

Mongin-Ferdinand de Saussure (1916: 30–1), trans. Roy Harris (1983: 13–14)

[A] LANGUAGE . . . is . . . a set of sentences . . . [–] all constructed from a finite alphabet of phonemes . . . [– which] may not be meaningful, in any independent sense of the word, . . . or . . . ever have been used by speakers of the language.

Avram Noam Chomsky, "Logical structures in language,"
American Documentation 8.4 (1957: 284)

Linguistic theory is concerned primarily with an ideal speaker-hearer, in a completely homogeneous speech-community, who knows its language perfectly.

Avram Noam Chomsky, *Aspects of the Theory of Syntax* (1965: 3)

The range of possible changes in an entity is inextricably linked with the nature of that entity. This is a truism, but that status does not make such an observation any less significant – or any less true. On a more abstract level, it is directly supported by the differential predictions concerning linguistic diachrony that follow from the above-cited characterizations of language (in general) associated with de Saussure (1916) versus Chomsky (1957, 1965). On the Saussurean view that *langue* is essentially the union of different speakers' linguistic systems, an innovation such as one speaker's addition of an item to some lexical field (e.g., color terminology) may count as (an instance of) significant language change, since any alteration in the number of oppositions within some domain necessarily modifies the latter's overall structure. But no such conclusion follows from the Chomskyan focus on a language as a set of sentences generated by an idealized competence essentially representing an intersection defined over the individual grammars within a community of speakers.

As a more concrete example, consider the diachronic consequences of Lieber's (1992) synchronic attempt at *Deconstructing Morphology*, where it is argued that, in an approach to grammar with a sufficiently generalized conception of syntax (and the lexicon), there is in essence no need whatsoever for a distinct domain of morphology. On such a view, it clearly is difficult – if not impossible – to treat diachronic morphology as an independent area of linguistic change.² An idea of how drastic the implications of this approach would be for studies of change in particular languages can be quickly gained by picking out one or two written grammars and comparing the relative size of the sections devoted to morphology versus syntax (and phonology). For example, nearly two-thirds (138 pp.) of the main text in Press's (1986) *Grammar of Modern Breton* is devoted to morphology, as opposed to only 14 percent (30 pp.) for syntax and 21 percent for phonology (44 pp.). Nor is such "morphocentricity" (cf. also Joseph and Janda 1988) limited to "Standard Average European" languages or to what might be thought of as more descriptive works. Thus, for example, in Rice's (1989) highly theoretically informed *Grammar of Slave* (an Athabaskan language of Canada), the relative proportions are roughly the same: 63 percent (781 pp.) for morphology versus only 27 percent (338 pp.) for syntax and 10 percent (128 pp.) for phonology.³

While Lieber's morphological nihilism is admittedly an extreme position, it is by no means an isolated one. After all, morphology is so recurrently partitioned out of existence by syntacticians and phonologists alike that it has

even been called “the Poland of grammar” (cf.⁴ Janda and Kathman 1992: 153, echoed by Spencer and Zwicky 1998: 1). On the other hand, while phonology and syntax themselves – along with phonetics, semantics, and the lexicon – seem to be in no danger of disappearing from accounts of linguistic structure, there is constant variation and mutation (not to mention internecine competition) within and among the major approaches to these domains. Hence, even if there were unanimity among historical linguists concerning the mechanisms and causes of language change, most (if not all) diachronic descriptions of particular phenomena would still remain in a state of continuous linguistic change, as it were, due to the never-ending revisions of synchronic theories and hypotheses.⁵

The present volume attempts to make a virtue of necessity by promoting such manifestations of diversity and (friendly) competition. Subject only to practical limitations of space, time, and authorial independence, we have – for selected individual aspects of language change – tried to match each chapter that depends on a particular synchronic perspective with one or more opposing chapters whose approach is informed by a specific alternative take on linguistic theory and analysis. For example, chapter 14, which is imbued with DAVID LIGHTFOOT’S commitment to approaching syntactic change from a formal starting-point, can be juxtaposed with chapter 17, which reflects MARIANNE MITHUN’S exploration of functional explanation in both synchronic and diachronic syntax. This handbook thus follows an inclusive strategy that omits no traditional sub-field of historical linguistics (as opposed, say, to the exclusions which would result from accepting the diachronic consequences of Lieber’s whittled-down approach to synchronic grammar).

1.1.2 Pruning back the view that languages change like living organisms

However, in contrast to works like Pedersen’s (1924) book-length account of what was achieved mainly by Indo-Europeanists during the nineteenth century, or like much of James Anderson’s (1991) encyclopedia-article overview of linguistic diachrony, the present volume is most assuredly not a history of historical linguistics – and it is especially not a history of general linguistics.⁶ As a result, the various contributors to this book (apart from this introduction) make virtually no mention of certain positions concerning the nature of language and language change which were once quite common but have now been largely discredited, though not completely abandoned. Perhaps the most prominent such position involves approaches which find it productive to treat languages as organisms.

In the view of Bopp (1827, here quoted from 1836: 1), for example, languages must be seen “as organic natural bodies that form themselves according to definite laws, develop, carrying in themselves an internal life-principle, and gradually die off” (translation after Morpurgo Davies 1987: 84; see also the discussion and references there – plus, more generally, Morpurgo Davies

1998: 83–97 et passim).⁷ In this, Bopp followed the treatment of Sanskrit and other things Indic by Friedrich von Schlegel (1808/1977), whose own positive use of “organic” (German *organisch*) – roughly meaning “innately integrated but able to develop” (as opposed to “adventitious and merely ‘mechanical’ [*mechanisch*; cf. pp. 51–52]”) – was due less to his admiration (from afar) for comparative anatomy than it was to his familiarity with German Romantics (see Timpanaro 1972) like Herder (cf., e.g., 1877–1913: vol. 1, 150–2) and the natural philosopher von Schelling (1798, 1800). Going even further, August Schleicher (1873: 6–7) advocated treating linguistics as literally a branch of biology parallel to botany and zoology (for discussion, see Koerner 1978a, 1989; Tort 1980; Wells 1987; Collinge 1994a; Desmet 1996: 48–81 et passim; Morpurgo Davies 1998: 196–201 et passim; and their references on Schleicher):

Languages are natural organisms which, without being determinable by human will, came into being, grew and developed according to definite laws, and now, in turn, age and die off; they, too, characteristically possess that series of manifestations which tends to be understood under the rubric “life”. Glottics, the science of language, is therefore a natural science; in total and in general, its method is the same as that of the other natural sciences.

Yet one immediately wonders how such pioneering figures of historical linguistics could overlook the ineluctable fact that, as already pointed out by Gaston Paris (1868) in an early critique (p. 242):

[a]ll of these words (*organism, be born, grow . . . , age, and die*) are applicable only to individual animal life . . . [E]ven if it is legitimate to employ metaphors of this sort in linguistics, it is necessary to guard against being duped by them. The development of language does not have its causes in language itself, but rather in the physiological and psychological generalizations of human nature. . . . Anyone who fails to keep in mind this fundamental distinction falls into obvious confusions.

De Saussure (1916: 17, here quoted from 1983: 3–4) reacted to the organicism of Bopp and Schleicher in a rather similar vein: “[T]he right conclusion was all the more likely to elude the[se] . . . comparativists because they looked upon the development of languages much as a naturalist might look upon the growth of two plants.” But Bonfante (1946: 295) expressed matters even more trenchantly: “Languages are historical creations, not vegetables.”

While we are here constrained to extreme brevity (but see the above references), present-day diachronicians can draw from the organicism of many nineteenth-century linguists an important moral regarding cross-disciplinary analogies (and envy). It is certainly the case that, during K. W. F. von Schlegel’s and Bopp’s studies in Paris (starting respectively in 1802 and 1812) and during the period of their early writings on language (respectively c.1808ff and 1816ff), such natural sciences as biology, paleontology, and geology were quite well established and abounded with lawlike generalizations, whereas such social

sciences as psychology and sociology either had not yet been founded or were still in their infancy. Von Schlegel's and Bopp's formative experiences at this time were thus set against a general backdrop which included the wide renown and respect accorded to, for example, Cuvier's *principe de corrélation des formes* (formulated in 1800 and usually translated as "principle of the correlation of parts"; cf., e.g., Rudwick 1972: 104, and 1997: passim), which stressed the interdependence of all parts of an organism and thus functioned so as both to guide and to constrain reconstructions of prehistoric creatures. Hence it is not surprising that, lacking recourse to any comparably scientific theory of brain, mind, personality, community, or the like, such linguists as von Schlegel, Bopp, and later Schleicher were irresistibly tempted to adopt an organismal (or organismic) approach when they found lawlike correspondences across languages (or across stages of one language) and began to engage in historical reconstruction.⁸

This trend can be seen as following from a variation on a corollary of Stent's (1978: 96–7) assertion that a scientific discovery will be premature in effect unless it is "appreciated in its day." In this context, for something to lack appreciation does not mean that it was "unnoticed . . . or even . . . not considered important," but instead that scientists "did not seem to be able to do much with it or build on it," so that the discovery "had virtually no effect on the general discourse" of its discipline, since its implications could not "be connected by a series of simple logical steps to canonical . . . knowledge." (It was in this sense, e.g., that Collingwood (1946/1993: 71) described Vico's 1725 *Nuova scienza* ("New Science") as being "too far ahead of his time to have very much immediate influence.") In the case at hand, the relevant corollary is that scholars tend to interpret and publicize their discoveries in ways which allow connections with the general discourse and canonical knowledge of their discipline. More particularly, however, scholars in a very new field – one where canons of discourse and knowledge still have not solidified or perhaps even arisen yet – are tempted to adopt the discourse and canons of more established disciplines, and it is this step that nineteenth-century organicist diachronicians of language like von Schlegel, Bopp, and Schleicher seem to have taken. Seen in this light, their actions appear understandable and even reasonable.

What remains rather astonishing, though, is the fact that, even after the (more) scientific grounding of psychology and sociology later in the nineteenth century, a surprising number of linguists maintained an organicist approach to language. As documented in painstaking detail by Desmet (1996), a "naturalist linguistics" was pursued in France during the period from approximately 1867 to 1922 by a substantial body of scholars associated with the *École d'anthropologie* and the *Société d'anthropologie de Paris*, publishing especially in the *Bulletins* and *Mémoires* of the latter, in the *Revue d'anthropologie* or *L'homme*, and in the *Revue de linguistique et de philologie comparée* (*RdLPC*), a journal which they founded and dominated. Thus, at the same time as the *Société de linguistique de Paris* continued to enforce its ban on discussions concerning the origin(s) of language(s), a cornucopia of lectures, articles, and even books on issues

connected with the birth and death of language(s) as viewed from an organicist perspective (along with issues related to language vis-à-vis race) flowed from the pens of such now little-known scholars as Chavée, Hovelacque, de la Calle, Zaborowski, Girard de Rialle, Lefèvre, Regnaud, Adam, and Vinson (the last of whom had 237 publications in the *RdLPC* alone; cf. Desmet 1996).

Still, while this movement itself died out in France *c.*1922 (aging and weakening along with its major proponents),⁹ one can still document occasional instances of explicitly organicist attitudes toward language and language change within the scholarly literature of the last decade of the twentieth century and on into the first decade of the twenty-first. Yet this is an era when the increasing solidity and number of accepted cognitive- and social-psychological principles leave no room for a Bopp-like appeal to biology as the only available locus for formulating lawlike generalizations concerning linguistic structure, variation, and change. Still, for example, Mufwene (1996) has suggested that, in pidgin and creole studies, there are advantages to viewing the biological equivalent of a language as being not an individual organism, but an entire species – which, expanding on Bonfante’s (1946) above-mentioned aphorism, we may interpret as implying that, rather than being a vegetable, each language is an agglomeration of vegetable patches!

More provocative have been various organicist-sounding works by Lass, beginning especially with his earlier (1987: 155) abandonment of the “psychologicistic/individualist position . . . that change is explicable . . . in terms of . . . individual grammars.” Instead, Lass (1987: 156–7) claims that “languages . . . are objects whose primary mode of existence is in time . . . [– h]istorical products . . . which ought to be viewed as potentially having extended (trans-individual, trans-generational) ‘lives of their own’.” More recently, Lass (1997: 376–7) has reiterated and expanded this glottozoic claim, suggesting that we “construe language as . . . a kind of object . . . which exists (for the historian’s purposes) neither in any individual (as such) . . . nor in the collectivity, but rather as an area in an abstract, vastly complex, multi-dimensional phase-space . . . [a]nd having (in all modules and at all structural levels) something like the three kinds of viral nucleotide sequences.”

This sort of approach has already been compellingly and eloquently countered by Milroy’s (1999: 188) response to Lass’s (1997: 309 *et passim*) characterization of languages as making use of the detritus from older systems via “bricolage,” whereby bits and pieces left lying around get recycled into new things. After first asking how we can “make sense of all this without . . . an appeal to speakers,” Milroy further queries: “If there is bricolage, who is the bricoleur? Does the language do the bricolage independently of those who use it? If so, how?” Our own answer to Milroy’s rhetorical questions echoes former Confederate General George Pickett’s late-nineteenth-century riposte – “I think the Union Army had something to do with it” (cf. Reardon 1997a: 122, 237n.2, 1997b; Pickett 1908: 569) – to incessant inquiries concerning who or what had been responsible for the negative outcome of “Pickett’s Charge” at the battle of Gettysburg (July 1–3, 1863) during the American Civil War.¹⁰ That is, unlike

Lass (1980: 64ff, 1981: 268ff, 1997: *passim*), who comes perilously close (cf. especially p. xviii) to suggesting that – as Dressler (1985b: 271) critically puts it – “[i]t is not . . . individual speakers who change grammar, but grammar changes itself,” our view on the identity of the parties most responsible for linguistic change is, rather: we think speakers have something to do with it (see Joseph 1992; Janda 1994a).

And this conclusion leads us to the above-mentioned moral for students of language change which, to repeat, is provided by the history of linguistics, even though considerations of space dictate the virtually total further exclusion from this volume of that topic. Namely, given that human speakers (and signers) are the only known organisms which/who come into question as plausible agents of change in languages, it is incumbent on historical linguists to avoid the trap of reacting to their potential disillusionment with current research findings in psychology and sociology by giving up entirely on psychology and sociology – and, along with them, on speakers – and so turning too wholeheartedly to the “better understood” field of biology. It is the latter move, after all, which has lured scholars like Lass (1997) into treating languages as organisms, or at least pseudo-organisms. Learning a lesson from what can now be recognized as needless wrong turns in the work of K. W. F. von Schlegel, Bopp, Schleicher, and later *linguistes naturalistes*, we can conclude that it is better for diachronic linguistics if we stand for an embarrassingly long time with our hands stretched out to psychology and sociology than it is for us to embrace the siren of biological organicism.¹¹

It is thus no accident that the present volume apportions either entire chapters, or at least substantial portions of them, to various aspects of psycholinguistics (including language acquisition and the psychophysics of speech perception) – see the respective chapters by JOHN OHALA (22) and JEAN AITCHISON (25) – and to central topics in sociolinguistics (like social stratification, attitudes or evaluations, and contact) – as in the respective chapters by GREGORY R. GUY (8), SARAH GREY THOMASON (23), and WALTER WOLFRAM AND NATALIE SCHILLING-ESTES (24).

1.2 *On change – both linguistic and otherwise*

All things move, and nothing remains still . . . ; you cannot step twice into the same stream.

Heraclitus (c.540 BC – c.480 BC¹²), quoted by “Socrates” in Plato’s *Cratylus* (c.385 BC: 402A, trans. Harold N. Fowler (1926: 66–7))

Plus ça change, plus c’est la même chose.

“The more that changes, the more it’s the same thing” (often less literally as “The more things change, the more they stay the same” or “The more things change, the less things change”).

Alphonse Karr, *Les Guêpes* (“The Wasps”) (January, 1849), reprinted (1891: 305) in vol. 6 of the collected series

As the title of this introductory essay indicates, we believe that it is crucial for historical linguists to devote some attention to working toward an understanding of change overall, and thus to wrestling conceptually with the time dimension that accompanies all activity in this world.¹³ We therefore begin with some general thoughts about time and change, as well as the epistemology and methodology of historical research.

1.2.1 Lesser and greater ravages of time

Only this . . . is denied even to God . . . [:] / the power to make [undone] what has been done.

Agathon (c.400 BC), quoted in Aristotle's *Nicomachean Ethics*, VI. 2.6 (p. 1139b, l. 10) (c.330 BC), trans. H. Harris Rackham (1934: 330–1)¹⁴

As the sun's year rolls around again and again, the ring on the finger becomes thin beneath by wearing; the fall of dripping water hollows the stone; the bent iron ploughshare secretly grows smaller in the fields, and we see the paved stone streets worn away by the feet of the multitude. . . . All these things, then, we see grow less, since they are rubbed away.

(Titus) Lucretius Carus, *Dē rērum nātūrā librī sex* ("Six Books on the Nature of Things"), I. 311–19 (c.60 BC), transl. after Cyril Bailey (1947: I, 190–3, II, 643–50)

Imagine that you are a geologist and that you want to study an event¹⁵ such as the ongoing erosion – by wind and water – of an exposed sandstone hillside (recently denuded of its grass cover by fire) over the course of several decades. How should you go about this? More particularly, consider which option you would select if you were forced to choose between two polar-opposite possibilities. On the one hand, you are offered the opportunity to obtain a relatively continuous filmed record of the hillside and the forces affecting it, in the form either of a real-time videotape or of time-lapse photography (advancing at a rate of, say, one frame per minute). Alternatively, you will be limited to only two snapshots of the hillside, one taken at the beginning and one taken at the end of the relevant decades-long period – that is, when the originally smooth and sloping surface was first exposed to the elements, and then again after it had been worn down to corrugated flatness.

Few indeed, we venture to say, are those who would willingly choose the essentially static, before-versus-after view afforded by the latter alternative, with just two stages documented – given that, after all, it is so much less informative and revealing, that it omits the details showing the course of change, and that it leaves the mechanisms of the transition between initial stage and final stage to be reconstructed inferentially. The point here is not that such reconstructions are impossible to carry out. Indeed, if they are all that is available to a scholar, then she or he will tend to be content with them and to do with them what she or he can. Still, if options with more detailed

information are available, such as time-lapse photography (e.g., with 60 frames per hour) or even continuous videotaping (which later can be either excerpted or else viewed at high speed), then these will of course tend to be preferred. The second, interstitial-reconstruction alternative simply provides less of the information that is relevant for understanding the transition between two states whose spatiotemporal connectedness is beyond dispute even though they lie far apart chronologically.

Yet, before we turn from our brief encounter with research on geological change back to a focus on investigations of alterations in language(s), it is worth emphasizing that the relevant moral lesson provided by geology for historical linguists goes far beyond the fact that geologists indeed view diachronic data which fill in the gaps between the beginning and the endpoint of a change as being highly desirable in principle. Rather, in cases like ongoing studies of the behavior of Mount Etna, it is clear that geologists regularly take the practical step of putting their money where their mouth – of a volcano – is. As recently as 2001, newspapers were reporting that the Sicilian peak was producing spectacular lava flows moving up to 100 meters an hour – and this information comes largely from the “huge array of monitoring techniques” recently discussed by Rymer et al. (1998): for example, measurements of seismicity, ground deformation, and microgravity, or results derived from electromagnetic, magnetic, and gas geochemistry, and the use of remote sensing. The authors conclude (p. 335) that a full understanding of Etna’s volcanism over time will require “the more comprehensive acquisition and real-time analysis of continuous data sets over extended periods.”

Furthermore, the above-mentioned time-lapse photography of flowers, plants, and trees, which is so familiar to (present and former) schoolchildren from nature films, sometimes turns out to be a crucial tool in the discovery of botanical secrets. Milius (2000: 413), for instance, describes the 26-year-old mystery of a New Zealand mistletoe whose “hot-pink buds . . . open upside down . . . [.] stay[ing] connected at their tips but split[ting] apart . . . at the stem end” – the agency of particular birds (and bees) in twisting open these buds from the top became clear only through the use of “surveillance videos.” In short, actual research practice in the natural sciences makes it abundantly clear that scholars of virtually all disciplines have much to gain from studying the intermediate stages of changes, not just their before and after.

In historical linguistics, a revealing pair of terms has been adopted by a number of scholars in order to do justice to this crucial difference between (i) the juxtaposition of two temporally distinct states, regardless of the number of events intervening between them, and (ii) the transitional course of one event as it happened. As the most constant advocate of this distinction, Andersen (1989: 12–13) has stated:

[L]inguists have tended to take little interest in the actual diachronic developments in which a language tradition is preserved and renewed as it is passed on from speaker to speaker – which should be the historical linguist’s primary object

of inquiry. Instead . . . [.] they have focused . . . on *diachronic correspondences*, calling these metalingual relations “changes” . . . and speaking of them as of objects changing into other objects, bizarre as it may seem. . . . In other words, the word “change” has commonly been employed . . . not to describe anything going on in the object of inquiry – language in diachrony – but rather to sum up a reified version of the linguist’s observations. . . . In order to describe effectively the reality of diachronic developments, . . . the term “*innovation*” [can be used] to refer to any element of usage (or grammar) which differs from previous usage (or grammars). The notion of innovation makes it possible to break down any diachronic development (“change”) into its smallest appreciable constituent steps. [emphasis added]

In addition, however, some socio- and historical linguists (of varying persuasions) who employ the above notions find it useful to make a further distinction between an *innovation* – as the act of an individual speaker, regardless of whether or not it later catches on in a speech community – and a *change*, strictly defined as an innovation that has been widely adopted by members of such a community. Milroy (1992: 219–26), refining earlier discussion in Milroy and Milroy (1985), distinguishes between *speaker innovation* and *linguistic change*, while Shapiro (1991: 11–13, 1995: 105n.1), imposing a specific interpretation on the more general definition in Andersen (1989: 11–13), similarly reserves the term *change* “for an innovation that has ceased to be an individual trait and . . . [so has] become a social fact” (1995: 105n.1).

It is worth emphasizing that more than terminology is at stake here, because differing interpretations of the word *change* have sometimes led historical linguists to talk past one another. On the one hand, many works on grammaticalization surveyed here by BERND HEINE (chapter 18) focus on the beginning and endpoints of developments which stretch over so many centuries that their authors are virtually compelled to neglect numerous (sometimes even all) intermediate stages and hence to treat myriad static diachronic correspondences – in a rather direct manner – as outright changes.¹⁶ Many formalist treatments of diachronic syntax discussed by LIGHTFOOT (chapter 14), on the other hand, limit their accounts of language change primarily to an individual speaker’s innovations (especially those of a child). Yet the collective view of the variationist works discussed by GUY (chapter 8) is that expressed by Labov (1994: 310–11), who speaks of “change in language . . . [only] when other speakers adopt . . . [a] new feature . . . [, so that] the change and . . . [its] first diffusion . . . occur at the same time.” There is thus much to be said for recognizing the above-mentioned three-way distinction: namely, *diachronic correspondence* (juxtaposing two potentially non-adjacent times) versus *innovation* (initiated by an individual person at one particular time) versus *change* (requiring adoption, over time, by all – or at least much – of a group).¹⁷

Applying these distinctions to our above geological example, we can say that studying a diachronic correspondence like the relation between the starting-point and the endpoint of a hillside’s erosion could rarely, if ever, provide as much insight into that long-term phenomenon as detailed research on the

actual series of innovations which make up the overall change-process of erosion itself.

However, in doing historical linguistics, we are generally closer to being in the position of a geologist who has only two before-versus-after snapshots – or, perhaps more fittingly, only a pair of hand-drawn sketches based on two such photographs. Nearly all historians, in fact, confront (to varying degrees) this kind of yawning chasm amidst fragments of documentary evidence,¹⁸ a predicament which led the American scholar Charles Beard to say that, in doing history, “We hold a damn dim candle over a damn dark abyss” (cf. Smith 1989: 1247). In our own field, too, Labov (1994: 11) has noted that “[h]istorical linguistics can . . . be thought of as the art of making the best use of bad data,” though we would prefer to characterize the data in question as “imperfect.” That is, until recently, the devices available for making and storing historical records have been such as virtually to guarantee that the information preserved will of necessity be fragmentary or otherwise incomplete, and so possibly misleading, etc. – whereas “bad” implies mistaken, faulty, or false.¹⁹ Still, Labov’s point is well taken, and there sometimes are bona fide, or rather mala fide, hoaxes (e.g., this seems to apply to the so-called Praenestine fibula; see Gordon 1975; Guarducci 1984), where the bad data are of an evil sort. Indeed, as both MARK HALE and SUSAN PINTZUK stress in their chapters (7 and 15, respectively), there are many cases where the only way to study a change involves consulting fragments of documentary evidence such as texts, recordings, and the like²⁰ (and see sections 1.2.3.4 and 1.2.3.5 on “imperfections” in paleontological data).

Nor should we forget the fact that the overwhelmingly preponderant direction of spread for linguistic changes is generally believed to flow from colloquial speech to more formal speech and thence to documentary writing, despite occasional instances of the reverse. (As for the latter, there are, e.g., spelling pronunciations like *of[t]en* and sporadically attested backformations like *misle* ‘to mislead,’ variously rhyming with *fizzle* or *(re)prisal*, based on a reinterpretation of (visually presented) simple past or past participial *misled* as *misle-(e)d* rather than *mis-léd*.) Consequently, most research on language changes which date back before the era of sound recordings is actually focused on the penetration into writing of already-occurred changes, rather than on their ultimate origin in spoken language.²¹ And, even then, the texts (in the general sense) which are at issue are all subject to the vagaries of attestation, to the need for interpretation (e.g., of the relation between spelling and pronunciation, which is one focus of philology), and to problems regarding dating of composition, manuscript transmission, and scribal traditions, etc.²² Caution is thus always in order – for several reasons, as can easily be shown by a few brief examples.

1.2.1.1 *Historical evidence is like the sea: constant but ever-changing*

For one thing, not all (forms or sentences found in) texts are of equal status, particularly where normalized editions or collections of excerpts are concerned. Instructive in this regard is a scholarly exchange – cf. Lightfoot (1979, 1980),

Lieber (1979), and Russom (1982) – concerning the absence versus presence in Old English of so-called “indirect passives”: sentences of the type *I was recently given a book about cats*, in which a logical (grammatical relational) indirect object surfaces as the subject of a passive verb. Lightfoot (1979) started off this debate by claiming that Old English had only a non-transformational (lexical) passive, and thus that the Modern English transformational (syntactic) passive represents an innovation, basing this assertion on the apparent absence from pre-Modern English of indirect passives (which he viewed as necessarily non-lexical and hence syntactic).²³ Lieber (1979) then countered this claim by adducing four apparent instances of indirect passives from the Old English period. Russom (1982) settled the matter, however, by showing that these four examples all evaporate when subjected to closer examination. One case, for example, involves the passive of a verb that did not normally govern a surface indirect object (but instead two accusative objects), while two cases are actually alternative versions of the same example – cited elliptically in two different ways in Lieber’s source – which clearly involves (in its fullest form) an underlying animate direct object realized as a passive subject (or theme) on the surface, as in *The slave was given (to) the master*. The fourth and final case likewise shows an animate passive subject as theme, but it significantly also contains a true (underlying and superficial) indirect object that is inflectionally marked as such (by *-e*) via a conventional scribal sign (a macron over the final consonant) that is visible in the best editions of the text but missing from many secondary sources that cite the example, including the only one consulted by Lieber. Here, Russom’s careful assessment of the evidence from a philological standpoint (one taking original text, scribal practices, and overall context into account) proved crucial to an accurate assessment of the linguistic claim being made – and not only with respect to the synchronic status of an Old English construction, but also regarding an alleged change (versus the actual lack thereof) in the diachrony of English passives.

1.2.1.2 *Accidental gaps in the historical record*

Moreover, despite all the philological care in the world, even something as seemingly fixed as date of first attestation is not always a reliable indication of age. For instance, the word *éor* is attested very late in the Ancient Greek tradition, occurring only in glosses from the fifth century AD attributed to the lexicographer Hesychius, but it clearly must be an “old” word, inherited from Proto-Indo-European, since it seems to refer to female kin of some sort and thus appears to be the Greek continuation of PIE **swés(o)r* ‘sister,’ altered by the action of perfectly regular sound changes.²⁴ The complete absence of this word from the substantial documentary record of Greek prior to the fifth century AD, which covers thousands and thousands of pages of text, is thus simply an accidental gap in attestation. Further, oral transmission clearly can preserve archaic forms, as the evidence of the *Rig Veda* in Sanskrit shows, even though there is no (easy) way to assign a “first attestation” to an orally transmitted text.²⁵

1.2.1.3 *Delays in attestation – for example, of taboo words*

A similar issue arises with lexical items that have special affective or emotive value, such as the subset of taboo forms often called “curse words” – that is, expletives (fillers) of a particular sort. To take a comparatively mild example, the earliest citations in the *Oxford English Dictionary* (s.v.) for the English noun *shit*, attested since c.1000, reflect a purely referential use, with the relevant sense being ‘diarrh(o)ea, especially in cattle.’ The usage of this form as a “contemptuous epithet applied to a person” is documented only since 1508, while its extremely frequent contemporary (modern) use as an expletive (with the euphemistically deformed variant *Shoot!*) is not recorded in the *OED* at all. However, the word in question has clear cognate forms within Germanic (e.g., *Scheiss(e)* in German), and it arguably derives from an Indo-European prototype, given the formal and semantic parallels in related languages (e.g., Hittite *sakkar*, Greek *skô:r* ‘dung’). Moreover, there appears to be a panchronic and thoroughly human proclivity to employ lexical items with such meanings for affective purposes.²⁶ We therefore contend that the burden of proof ought to be on anyone who claims that its expletive use is only a recent phase in the more than 5,000-year history of the word at issue in this paragraph.²⁷

1.2.1.4 *High-prestige data can come from once low-prestige sources*

Furthermore, even when some specific set of documents – or, with luck, an entire textual genre – characteristic of a particular linguistic period happens to be preserved in nearly or (*mirabile dictu*) completely pristine form,²⁸ we do well to remind ourselves of the apparently ubiquitous bias favoring the creation and preservation of religious, legal, commercial, and literary texts over written representations of informal speech. Now, it is in the very nature of holy scriptures, stabilizing laws, binding contracts, and monumental epics to promote the iconic equating of fixation in writing with fixity of language, and of intended invariance over time with imposed linguistic invariance.

As Rulon Wells (1973: 425–6) once eloquently put it:

[T]here was never a time in biology when the study of fossils was more highly esteemed than the study of living plants and animals . . . [, whereas] it was only after centuries of debate that the study of living languages and literatures (written or oral) came to be considered not inferior to the study of Latin and Greek. And the debate was, in effect, ended sooner for literature than for language: the “progressive” view prevailed, very broadly speaking . . . [.] for literature already in the Enlightenment, but for language not until romanticism . . . In biology, per contra, it was generally recognized that if, e.g., one classified fossil molluscs exclusively according to properties of their shells, this basis of classification, used for lack of anything else, was forced upon us by the circumstance . . . that only their hard shells, and not their soft inner vital parts, . . . [were] preserved . . . [. But, eventually, t]his view [was] attained in the nineteenth century . . . [:] that we lacked information about such vital parts of the classical languages as their . . . intonation, the details of their pronunciation, and the full extent of differences of dialect, social class, and style within them.

In the twentieth century, on the other hand, it was well into the 1960s and even the 1970s before William D. Labov's findings concerning the greater consistency and even systematicity of informal speech-styles firmly impressed themselves on the minds of linguists. We have in mind such quantitative results as those of Labov (1989a: 13–14, 17–18) concerning speakers of Philadelphia English. Even though the spontaneous speech of a representative sample of these speakers was characterized by 99–100 percent consistency (with 250 clear tokens versus 1 ambiguous case) in realizing the lexical – that is, phonemic – contrast between low, lax /æ/ in *sad* versus raised, centralized /æh/ (phonetically [e^h]) in *bad*, *glad*, and *mad*), there was only 73–7 percent consistency (depending on the evaluation of difficult-to-interpret tokens) in the realization of this pattern within the more formal style involved in reading word-lists aloud. And even elicitation-style (i.e., focused interrogation of the sort that asks questions like “What do you do/say when such-and-such happens?”) was only 90–6 percent consistent for /æ/ versus /æh/. Simultaneously, that is, writing tends to favor both conservatism and hypercorrection.

In short, there is little we can do to change the circumstance that the texts which most often tend to be written and preserved are those which least reflect everyday speech.²⁹ But we can at least admit our awareness of this situation, and concede that it obliges us to use extreme caution in generalizing from formal documents. After all, in the words of Bailey et al. (1989: 299): “[T]he history of . . . language is the history of vernaculars rather than standard languages. Present-day vernaculars evolved from earlier ones that differed remarkably from present-day textbook[-varieties] . . . These earlier vernaculars, rather than the standard, clearly must be . . . the focus of research into the history of . . . [languages].” In fact, this view had already been just as forcefully expressed at the beginning of the twentieth century by Gauchat (1905: 176), who referred to “spoken dialects” as “living representatives” which can provide evidence regarding “the phases which the literary languages have passed through in the course of time . . . [; t]he vernaculars . . . can serve as our guides in helping us to reach a better understanding of academic [varieties of] languages.”³⁰

1.2.1.5 *The first shall be trash, and the trash shall be first*

To this pithy encapsulation of the diachronic linguistic facts, we would only add that modern-day archeology and paleontology are replete with suggestive parallels likewise involving the subsequent historiographical valorization of phenomena whose worthlessness or even repulsiveness could only seem obvious both to cohorts in the past (human or otherwise) and to laypeople in the present. To take a specific and extreme example: probably the most revealing and reliable information regarding the diet and activities of the prehistoric Egyptians living at Wadi Kubbania (near modern Aswan) c.18,000 years ago comes from the analysis of “charred infant feces, so identified by their size . . . , [which had been] swept into . . . [camp]fire[s]” (cf. the summary in Fagan 1995: 92–3, 264, plus the fuller account in Hillman 1989). Similarly, the controversial

question of whether members of the dinosaur family *Tyrannosauridae* (now extinct for tens of millions of years) were principally predators or scavengers is now beginning to be resolved on the basis of *Tyrannosaurus rex* coprolites (see, e.g., Chin et al. 1998). This is because “histological examination of bone in coprolites can give the approximate stage of life of the consumed animal” and thus show whether *Tyrannosauri reges* tended to prey on the youngest and oldest (hence most vulnerable) members of herds or instead to scavenge on carrion of all ages, gregarious or not (cf. the more accessible discussion in Erickson 1999: 49).³¹ In short, as Rathje (1978: 374) has put it so well (in the context of justifying studies of present-day waste products along with ancient ones; cf. also Rathje 1974): “All archeologists study garbage; the Garbage Project’s raw data are just a little fresher than most.” Similarly, Rathje (1977: 37) draws special attention to a dictum of “[a]rcheology pioneer Emil Haury . . . [:] ‘If you want to know what is really going on in a community, look at its garbage.’”³²

Among the situations in historical linguistics to which findings like the above are strikingly similar, we here mention three. First, there is the fact that the most revealing evidence concerning the history of Romance languages comes not from Classical Latin texts, but from Vulgar Latin like that found in the graffiti of Pompeii (volcanically fixed in 79 AD) and from the later list of stigmatized forms excoriated in the so-called “Appendix of Probius” (late fourth century); cf., for example, Elcock and Green (1975: 35–8, 40–6). What some upstanding Pompeiians thought of the graffiti in question is revealed by a contemporary addendum (written in classical meter) which Elcock and Green render as “I wonder, o wall, that you have not fallen in ruins, / since you bear the noisome scrawl of so many writers.” A second such case concerns the short non-literary Latin texts, mostly from c.100 AD, found on small pieces of wood (c.10 cm by 10 cm) that had been used for everyday records and messages at the Roman fort of Vindolanda (now near Chesterholm, Northumberland) in northern England; see the discussion and references in Grant (1990: 129–33, 234–5). Precisely because of their non-Classical spelling and grammar, these texts by humble soldiers and their families have recently been described as priceless – yet, shortly after they were written, many of the messages “were evidently deposited in a rubbish dump,” while “others were found in drainage areas, suggesting that they had been flushed away” (p. 132).³³

Our third and final example of this type shows particularly clearly how seemingly throwaway texts can provide crucial evidence regarding the dating of specific linguistic changes. This instance comes from Old High German (OHG) and concerns rough drafts (*Vorakte*) from the eighth to ninth centuries which happened to be preserved in the northeastern Swiss monastery of St Gall – even though (most of) the filed official documents (*Urkunden*) based on these drafts were also preserved and so might have been expected to allow the discarding of the latter. As documented in detail by Sonderegger (1961: 253, 267–8, 1970: 34–9), the fortuitously preserved rough versions of many OHG legal documents written in St Gall c.800 AD are several decades ahead of the

officially filed final versions in consistently designating the primary umlaut (i.e., to short *e*) of OHG *a*. In an example pair from 778, for instance, the draft form (*H*)*isanherio* – a man's name – was changed to *Isanhario* for the final version, and a pairing from 815 similarly matches the name spelling *Uurmheri* in a draft with the rewritten final form *Wurmhari*. Due to the serendipitous preservation of the St Gall rough drafts, then, a more accurate initial-stage chronology for the much-discussed process of umlaut as it occurred in (Alemannic) OHG could be arrived at (cf. Janda 1998a) without that process meeting an otherwise certain fate of being assigned far too late a date. But we are rarely so lucky.

1.2.1.6 *Broken threads in the histories of languages*

In sum, then: no matter how carefully we deal with documentary evidence from the past, we will always be left with lacunae in coverage, with a record that remains imperfect and so confronts us with major chasms in our understanding that must somehow be bridged. And “chasm(s)” is sometimes a charitable characterization of the impediments that bedevil the pursuits of diachronic linguists. Surprisingly often, the discontinuities posed by apparent gaps are compounded many times over when it turns out that what we actually face is not an interruption of a single linguistic tradition, but the end of one line of language transmission and the beginning or recommencement of a related but distinct line. Precisely such a situation obtains in the case of English – one sufficiently well known to receive mention in a popularizing work like the imposing encyclopedia compiled by Crystal (1995: 29):

Most of the Old English corpus is written in the Wessex dialect . . . because it was th[e speech of the West Saxon] . . . kingdom . . . [.] the leading political and cultural force at the end of the ninth century. However, it is one of the ironies of English linguistic history that modern Standard English is descended not from West Saxon but from Mercian, . . . the [ancestor of the Southeast Midland] dialect spoken . . . in . . . [and] around London when that city became powerful in the Middle Ages.

That is, it is more or less impossible to carry out a direct tracing of West Saxon linguistic trends from late Old English into early Middle English, since Wessex speech is so sparsely attested after the Norman Conquest, and it is simultaneously impossible to pursue the direct antecedents for the early Middle English form of Southeast Midland speech back into the late Old English period, due to the dearth of Mercian texts in that earlier era.³⁴ In terms of the eroding-hillside analogy used above in the beginning of section 1.2.1, not only do cases like the one just mentioned limit analysts to dealing with (drawings of) just two photographs; they also force scholars to work with before-and-after photographs of different (albeit similar and neighboring) hillsides. Let us mention just one more related hurdle: Lass (1994: 4n.2) mentions a curious paradox of temporal misalignment which Dieter Kastovsky (pers. comm.) had once pointed

out to him – the fact that, even in the normalized and hence homogeneous-seeming treatments of Old English typically found in historical grammars, “the phonology usually referred to in the[se] handbooks is that of the ninth to tenth centuries, but the morphology and syntax is that of the tenth to the eleventh.” As if it were not already bad enough that seeking historical explanations for linguistic phenomena sometimes seems like looking for the Loch Ness monster, the many discontinuities involved should make us wary that alleged images of the monster may actually show not only the front part of one creature and the tail of another, but even the head of one creature, the neck of another – and so on. Exorcising such multiple demons may be a holy endeavor, but endeavoring to study language change is unavoidably a holey exercise (though undeniably of wholly consuming interest to its practitioners). Kroeber (1935: 548) said it perhaps best of all: “More useful is the definition of a historian as one who ‘knows how to fill the lacunae.’”³⁵

1.2.1.7 *Historical linguistics versus presently imperfect records of the past*

There is little doubt, then, that one fundamental issue in historical linguistics concerns how best to deal with the inevitable gaps and discontinuities that exist in our knowledge of attested language varieties over time. This book as a collective whole is largely an attempt to answer this key question as it pertains to language and related cultural phenomena.

One (partial) reponse is that – to put matters bluntly – in order to deal with gaps, we speculate about the unknown (i.e., about intermediate stages) based on the known. While we typically use loftier language to characterize this activity, describing the enlightened guesses in our speculations with more neutral names like “sober hypotheses that can be empirically tested,” the point remains the same. In this respect, one of the relatively established aspects of language that can be exploited for historical study is our knowledge of the present,³⁶ where we normally have access to far more data than could ever possibly become available for any previously attested stage (at least before the age of audio and video recording), no matter how voluminous an earlier corpus may be.

We focus on this application of the present to the past in the following section. Still, it is important to note first that some linguists have suggested that there can be too many data available for some stage of a language, and that such a situation can get in the way of a clear understanding of what is going on. Thus, for example, in the view of Klein (1999: 88–9): “[L]ass (1997) makes the important paradoxical point that, despite our interest in taking into account as much data as possible in applying the comparative method, too much data can sometimes be a hindrance in that it may muddle the picture by making it harder to know what forms to take as input to the method.” Stronger statements than this are hard to find in print, but one of us was once told by a former historian colleague at the University of Chicago: “Study the present as history in progress? Don’t do that, or you’ll drown in the data!” As regards

current and future progress in increasingly skilled applications of the comparative method (see chapter 1 by RANKIN, chapter 2 by S. P. HARRISON, and HALE's chapter 7), we agree with the view that some careful sifting of available data is needed. But, with regard to the question of understanding how languages change, it is clearly the case that, the more enriched our view is of what holds for any given language state, the better and therefore the more enriched will be our view of the historical developments which led to that state or which emerged from that state (remember again the eroded hillside washed and blown away above, from section 1.2.1).

One angle on utilizing the present for the illumination of the past is linguistic typology, as emphasized nearly half a century ago by Roman Jakobson (1958: 528–9): “A conflict between the reconstructed state of a language and the general laws which typology reveals makes the reconstruction questionable . . . A realistic approach to a reconstructive technique is a retrospective road from state to state and a structural scrutiny of each of these states with respect to the typological evidence.” In this way, knowledge gained from a survey of the various features that synchronically characterize the range of the notion “possible human language” can be used as a means to gain insights into possible synchronic stages in the past. For instance, suppose it turns out to be a valid (linguistic-universal) generalization, as Jakobson (1958: 528) also claimed, that “as a rule, languages possessing the pairs voiced–voiceless . . . [and] aspirate–nonaspirate . . . have also a phoneme /h/” – that is, that there are no languages with aspirated stops that do not also have [h].³⁷ Suppose, further, that one is faced with the task of accounting for the transition from a language state with [p^h t^h k^h] and [h] to one with [f θ x] but no [h].³⁸ It would seem reasonable to posit an initial stage with [f θ x h], prior to the stage with [f θ x] but no [h], rather than positing (contrary to the above-mentioned alleged universal) first the loss of [h], with the subsequent survival for some period of the aspirated stops. We would in this way be using information gleaned from the present to guide hypotheses about putative language states in the past. Crucially, our hypotheses in such cases are only as valid as the strength and certainty of our typological information and putative language universals,³⁹ but the methodological practice of using typology as a heuristic and a guideline for hypotheses regarding the past is what it is instructive to draw attention to here.⁴⁰

Typology (or at least typologists) can be said to come in two flavors, however. One approach views typological gaps as constituting an interim report suggesting but not demonstrating the systematic absence of some phenomenon (or, conversely, the presence of some negative constraint). On this view, any qualitatively unique linguistic element or structure newly proposed for some language(s) is viewed with suspicion – since it has the defect of lacking independent motivation – but it is not treated as *a priori* impossible. Another approach to typology, though, is tempted either to reject unique phenomena, almost out of hand (e.g., as being the result of observational or analytical error), or to reanalyze each of them as a marked variant of an existing (more robustly motivated) phenomenon. This latter perspective might make more

sense if more of the world's thousands of languages and dialects had been thoroughly, cogently, accessibly described, but our present state of knowledge about current linguistic diversity around the globe is seriously incomplete. As a result, many typological slots cannot be regarded as anything more than provisionally unfilled – especially since, from time to time, apparently unique elements and structures turn out to be more common than was originally thought. Thus, for example, Ladefoged and Maddieson (1996: 18–19, plus references there) discuss sounds produced by “moving the tongue forward to contact the upper lip” – for example, the “series of linguo-labial segments . . . [found] in a group of [Austronesian] languages from the islands of Espiritu Santo and Malekula in Vanuatu” (cf. the sequence of photographs, Ladefoged and Maddieson 1996: 19, showing the production of such a sound in Vao), and they also mention similar sounds elsewhere in the world.

Given the surprising frequency of such discoveries, a less absolutist approach to language typology seems preferable, and we would wager to say that this perspective is indeed the predominant one in current synchronic typologizing. Nevertheless, in mentioning above that typology often plays a role in historical linguistic reconstruction, we have already implicitly indicated that typology has a diachronic dimension, as well. Intriguingly, though, many historical linguists have been quite absolutist in their invocations of typology – to the point where, for example, Watkins (1976: 306) could complain that the “typological syntax” of Lehmann (1974) and others had led to “a theory which elevate[d] . . . some of Greenberg’s [(1966)] extremely interesting quasi-universals to the dubious status of an intellectual straitjacket . . . into which the facts of various Indo-European languages . . . [had to] be fitted, willy-nilly, rightly or wrongly.”

As it turns out, projections of absolutist synchronic typology onto a diachronic axis are often discussed by historical linguists in connection with (or even as constituting) the so-called “uniformitarian principle” (or “hypothesis”). This notion has been variously defined, as can be seen by comparing the version given in Labov (1972a: 275) – “the forces operating to produce linguistic change today are of the same kind and order of magnitude as those which operated in the past” – with either of the two versions later provided in Hock (1991b: 630), the second of which states that “[t]he general processes and principles which can be noticed in observable history are applicable in all stages of language history.” In devoting the next section entirely to the nexus of issues centering on uniformitarianism, we have been guided by two main considerations. On the one hand, this (sort of) principle continues to figure prominently in contemporary discussions of language change. On the other hand, the “principle” itself is also revealed by closer inspection not only to be entirely derivable from other (irreducible) principles but also to be bound up with a number of lingering controversies, for some of which it seems that at least one of the contending parties is not fully informed about the relevant opposing views – hence the second part of the following section title. For readers who have either just acquired or always felt an antipathy toward the (nine-syllable length of the) term *uniformitarianism*, we should immediately mention that our eventual

conclusion will be that the relevant concept is better expressed under an alternative rubric like “informational maximalism.”

1.2.2 *Uniformitarianism(s) versus uninformed tarryin’ -isms*

All sequences of events based on human activity can be viewed as natural – that is, as causally determined developments in which every stage must be understood with reference to the combinations and tensions of the preceding stage. In this sense . . . [,] one does not need to distinguish between nature and history, since what we call “history”, if seen purely as a course of events, takes its place as part of the natural interrelationships of world happenings and their causal order.

Georg Simmel, “Vom Wesen der Kultur,” *Österreichische Rundschau* 15 (1908), reprint in Simmel (1957: 86); trans. Roberta Ash (1971: 227)

[T]hose who, maintaining the historicity of all things, would resolve all knowledge into historical knowledge . . . argu[e:] . . . Might not a . . . revolutionary extension sweep into the historian’s net the entire world of nature? In other words, are not natural processes really historical processes, and is not the being of nature an historical being?

Robin George Collingwood, *The Idea of History* (1946), re-edited (1993: 210)

While one is admittedly not likely to run into the term *uniformitarianism* outside of historical linguistics and other disciplines which deal with change(s) over time, the central concept behind this apparent sesquipedalianism is actually quite hard to avoid and/or ignore. For example, if a diachronician of any sort tries to escape from his or her subject by planning a vacation visit among the miles of snowy-white gypsum dunes in White Sands National Monument near Alamogordo, New Mexico, he or she may pick up Houk and Collier’s (1994) guide to the dunes and there read (on p. 18):

Ancient sand dunes are the building blocks of many of the earth’s sedimentary rocks . . . Geologists have studied these rocks all around the globe . . . [,] peer[ing] back into the past . . . But the best instrument for studying the past is a sound understanding of the processes operating in the present . . . White Sands . . . offer[s] . . . geologists a perfect opportunity to study sand in the process of being deposited.

In fact, even non-geographical attempts to escape the long reach of uniformitarianism are ultimately doomed to failure. That is, any historically minded scholar who enjoys hiding temporarily in detective novels as a form of escape literature probably will eventually read some of G. K. Chesterton’s Father Brown stories – among which is “The Strange Crime of John Boulnois” (published first in 1914), whose title character writes on “Catastrophism” and so is a

presumptive opponent of uniformitarianism. (Boulnois, an “Oxford man,” has challenged “alleged weak points in Darwinian evolution” via his counter-proposals involving “a comparatively stationary universe visited occasionally by convulsions of change” – which anticipates our later discussion, in sections 1.2.3.4 and 1.2.3.5, of “punctuated equilibrium” – though that is not his crime; cf. Chesterton 1929: 292–304.) In short, if uniformitarianism gives the impression of being uniformly present in disciplines which possess a diachronic component, or even just some kind of historical relevance, that is probably an accurate impression.

Virtually all scholars engaged in historical pursuits agree that uniformitarianism, at a minimum, has something to do with the relevance of the present for the study of the past. Several factors provide the crucial support for this conclusion and hence justify using considerations connected with the present as a means to elucidate the past. One such factor is sheer practicality: that is, the present (i.e., non-relic-like elements of the present – ones which lack unmistakable traces of a different past existence) are normally more directly accessible than is the past (i.e., those aspects of a former past identifiable from traces carried over into the present), and so we are able to study the present in ways that are unavailable for the study of the past: by reinterviewing someone, for instance. A more logic-oriented factor, though – and certainly a more compelling one – has to do with what can be called *independent motivation*. That is, since present-day entities and processes, being investigable in great detail before our very eyes, can be established with relative certainty, they are also available to be exploited for the purpose of proposing descriptions and explanations for phenomena – linguistic or otherwise – which occurred before our lifetimes, or even before the time of the earliest records kept by humans.

Lurking behind the scenes here, as the foundational core of this discussion, is the principle of parsimony (a.k.a. economy), which – despite its frequent association with a particular Franciscan theologian and philosopher who lived c.1285–1349 (his identity is “revealed” below) – was actually first invoked by Aristotle (384–322 BC) in his *Posterior Analytics*, his *Physics*, and his *Of the Heavens* (each time in a slightly different phrasing) For example, in chapter 25 of book 1 from the first of these (written c.350 BC), Aristotle states (in our adaptation of a 1960 translation by Hugh Tredennick) that:

it may be assumed, given the same conditions, that that form of demonstration is superior to the rest which depends on fewer postulates, hypotheses, or premises – for, supposing that all of the latter are equally well known, knowledge will be more quickly attained when there are fewer of them, and this result is to be preferred.

This methodological principle of Aristotle’s was well known to the most prominent figures of medieval scholasticism. It was thus regularly quoted and discussed in works – written mainly in the period from c.1225 to c.1325 – by authors like Robert Grosseteste, (St) Bonaventure, (St) Thomas Aquinas,

Henry of Ghent, Duns Scotus, and Peter Aureol, who also favored certain paraphrases of their own, such as (here translated from the Latin) “It is useless to explain by several things what can be explained by one”; cf. Maurer (1978: 405). But the concept at issue is in fact not now typically referred to either in this or in Aristotle’s phrasing. Instead, it is most often encountered in a formulation widely known from the philosophical and scientific literature as “Ockham’s razor,” a name that arose in the mid-seventeenth century because parsimony as an entity-shaving device had become closely associated with a late scholastic writer, English-born William of Ockham (the above-mentioned Franciscan theologian and philosopher), who invoked it with particular frequency.⁴¹ Still, the precise phrasing of the principle which most linguists and other scholars associate with Ockham was not in fact ever used (literally) by him. Rather, it appears to be post-medieval and was first attested in the seventeenth century, later becoming famous when it was prominently mentioned by Leibniz: “Entities are not to be multiplied without necessity” – that is, “without independent motivation.” The closest that Ockham ever came to writing this was in his statement(s) that “a plurality never is to be posited without necessity” (in the Latin form “*pluralitas numquam est ponenda sine necessitate*”; cf. again Maurer 1978: 405). At any rate, it can indeed be demonstrated that what has been called Ockham’s razor in fact holds Aristotle’s blade.

Now, in the case of language change, working backwards from a knowledge of the present is clearly (equivalent to) a way of “depending” on “fewer postulates” (since it does not rely on entities postulated for the past without any other motivation), and it also just as clearly does not needlessly multiply entities (within a particular account), since constructs that are needed independently for explaining the present are pressed into service as parts of an explanation for the past. The methodological step of working backwards from the present – advocated, for instance, by Labov (1972aff) (as already noted above) – is thus licensed by both Aristotle’s and Ockham’s versions of the parsimony principle.

Another key factor that must be summoned into play here, though, is the assumption that the laws of nature are the same at all times and in all places. This crucial assumption – though sometimes treated as in essence a principle, too – is really nothing more than the result of another application of Ockham’s razor (with Aristotle’s blade), and thus likewise follows from the principle of parsimony. In a paradoxical sense, however, this concept is often treated as axiomatic – for the reason that, without some such orienting concept as an underpinning for investigations of the past, there would be no principled way to establish meaningful comparisons between different time(period)s, since the “ground rules” (so to speak) would then be free to differ from era to era. Moreover, it then would presumably be very difficult to determine (whether anyone could know) what the temporal locus is of the point(s) in time where a transition from one set of natural laws to another distinct set occurs, since such a difference could set in even from one moment to the next. One surely cannot – for obvious reasons – legitimately propose generalization of the following type: at sea level, water now always boils at 100°C, because it has done

so ever since the exact moment on the morning of May 13, 2,000,000,000 BC, when Mickey's little hand was on the nine and his big hand was on the twelve – though the relevant boiling temperature had earlier always been 200°C. (On the general subject of time, especially as it relates to language change, see section 1.3 below.)

Much more can and should be said about “uniformitarianism” in its various avatars – and not just because (as befits a principle that frequently comes up in the course of historical linguists' musings on language change) both the history of the term itself and the ways in which it came to be applied in studies of language change prove to be enlightening. Rather, there really are major points of dispute latent in the differing definitions and interpretations that have been offered for this concept, with significant consequences relating, for example, to what can and cannot be achieved by reconstruction. We address a number of these issues in the section that follows (though we will have to reserve more extensive discussion for some other, later occasion).

1.2.2.1 *“Multiple meanings of uniformity and Lyell's creative confusion”*

While scholars are sometimes tempted to inveigh against certain (in their opinion) perverse ways in which other people – including scholars – use particular terms, it is usually best if they try to resist this temptation. In rare cases, though, it seems that some such policing of terminology would actually have been well advised, since it would apparently have staved off a certain amount of confusion and spared a great deal of otherwise wasted time and effort. Such a yearning to manage scientific terminology is perhaps most justified in the case of labels whose morphological transparency suggests that they have equally obvious semantics – a situation which readily invites misinterpretation of technical usage, especially when forms are borrowed from another field. All these factors seem to have been at work in linguists' misappropriation of the geological (and biological) term “uniformitarianism,” and so we devote most of this subsection to keeping the relevant strands apart – in doing which we follow the model from geology established by Gould (1987), and so take our title from that of the corresponding subsection (pp. 117–26) of his monograph.

A scholar encountering *uniformitarianism* for the first time would surely recognize the base stem *uniform-(ity)*, and so ask: “But uniformity of what?” – only to answer, perhaps in the next breath, “Why, uniformity of law, certainly!”: that is, the above-mentioned parsimony-derived principle that natural laws are constant across space and time. Yet probably another consideration would soon come to mind, one involving the slightly extended (and likewise previously mentioned) parsimony-derived assumption that such uniformity of law allows one to view the present as a key to the past: any process now observable thereby becomes available to be invoked as part of a plausible explanation for past events – this principle is that of “uniformity of process through time.” This and the previous interpretation are both aspects of uniformitarianism that make eminent sense; indeed, their validity has already been argued for above. Moreover, these notions are in keeping with two specific cases already

discussed here previously. One of these concerned the assumption that, given what we know about variation in modern languages, there cannot really have been as little diversity in spoken Gothic as the relatively variation-free documentary record suggests (cf. n. 28); the other case involved the application to reconstruction of synchronically based observations concerning linguistic typology (recall section 1.2.1.7).

Things start to go wrong, though, when historical linguists and/or other diachronicians view principles like these as having been first introduced into the scientific arena by nineteenth-century British (and, later, American and German) geologists led especially by Sir Charles Lyell. Quite on the contrary: as we document below, numerous historians of geology and biology over the past forty years have emphasized that explicit appeals to such uniformity of law were already common practice among Lyell's geological and biological contemporaries and predecessors (a number of whom he did not portray in a positive light). Moreover, Lyell's own innovative uniformities – namely, uniformity of rate (a.k.a. uniformity of effect) and uniformity of state (a.k.a. uniformity of configuration) – have not held up well at all.

Lyell (1830–3: *passim*) claimed in particular that geological change is “slow, steady, and gradual” (and not cataclysmic or paroxysmal) – cf. Gould (1987: 120) – because such floods, earthquakes, and volcanic eruptions as do occur are strictly local catastrophes. While this turns out to be true most of the time, it is by no means true all of the time, and Lyell's insistence that “the earth has been fundamentally the same since its formation” (argued by Gould 1975/1977 to have been the type of uniformity “closest to Lyell's heart”) was abandoned even by its author before the end of his life, essentially because it had been empirically falsified by the documented phenomena of complete extinction and speciation evolution which had been championed by his protégé, Charles Darwin.

That the original sense of “uniformitarianism” involved Lyell's uniformity of rate is clear from the context within which Whewell (1832: 126) coined this long term, since Whewell suggested that the question of “uniform . . . intensity . . . [would] probably for some time divide the geological world into two sects, . . . the *Uniformitarians* and the *Catastrophists*” (original emphasis). The crucial missing element here is that there really were two kinds of catastrophists: what can be called “scientific catastrophists,” like Whewell and the French paleontologist Cuvier, and what can be called “religious catastrophists,” like Buckland (1836). Lyell wrote as if he were refuting all catastrophists, but in fact he was refuting only religious catastrophism. Yet, within geology, religious catastrophism no longer needed refutation at the time of Lyell's writing; cf. Gould (1975/1977: 149):

By 1830, no serious catastrophists believed that cataclysms had a supernatural cause or that the earth was [only] 6,000 years old. Yet . . . these notions were held by many laymen . . . and . . . some quasi-scientific theologians. A scientific geology required their defeat, [for which scientific] catastrophists . . . praised Lyell because he brought a geologic consensus so forcefully to the public.

In short, as pointed out by Gould's (1987: 118–19) extensive and eloquent study of Lyell as a "Historian of Time's Cycle" (expanding on the start already made in Gould 1965):

Lyell united under the common rubric of uniformity two different kinds of claims – a set of methodological statements about proper scientific procedure, and a group of substantive beliefs about how the world really works. The methodological principles were universally acclaimed by scientists, and embraced warmly by all geologists; the substantive claims were controversial, and, in some cases, accepted by few other geologists . . . [In short,] Lyell . . . pulled a fast one – perhaps the neatest trick of rhetoric, measured by subsequent success, in the entire history of science. He labelled . . . different meanings as "uniformity" and argued that since all working scientists must embrace the methodological principles, the substantive claims must be true as well.

But, in so doing, Lyell (1830–3) achieved more than just an ephemeral accomplishment, more than a temporary victory. Rather, his strategy worked so well that he earned himself a lasting place in the history of geology *on his own terms* – an extremely rare and truly stunning coup. Thus, as Gould (1975/1977: 142) goes on to emphasize:

[m]ost geologists would tell you that their science represents the total triumph of Lyell's uniformity over unscientific catastrophism. Lyell . . . won the victory for his name [and term], but modern geology is really an even mixture of two scientific schools – . . . original . . . uniformitarianism and . . . scientific catastrophism. . . . We accept . . . [the] two uniformities [(of law and process)], but so did the catastrophists. Lyell's third uniformity [(of rate/effect)], appropriately derigidified, is his great substantive contribution; his fourth (and most important) uniformity [(that of state or configuration)] has been graciously forgotten.

With so many senses of "uniformitarianism" struggling with one another in the geological trenches, it is not really surprising that historical linguists should show a correspondingly high degree of variation in their understanding and use of the term in question. The great frequency with which one encounters the rate-oriented interpretation of the concept appears to show, on the one hand, how strong an influence was exercised by a concentrated set of publications by Labov during the decade 1971–81 and, on the other hand, exactly how little attention is sometimes paid by readers in certain fields to the titles of books.

As regards the former point, it is useful to juxtapose with each other the primary statements made about uniformitarianism in the first two publications of the series Labov (1972a, 1974/1978, 1981). Repeating from earlier the remarks of Labov (1972a: 275) in *Sociolinguistic Patterns*, we can note that the definition there speaks of a principle such that "the forces operating to produce linguistic change today are of the same kind and [the same] order of magnitude as those which operated in the past." This is quite similar to – but

also (in that it mentions magnitude) slightly stronger than – Labov’s (1974/1978: 281) definition in “On the use of the present to explain the past.” In the latter work, there is a statement to the effect that, in “apply[ing] principles derived from . . . sociolinguistic studies of change in progress . . . [to the study of language change in the past], we necessarily rely upon the uniformitarian principle – that . . . the forces which operated to produce the historical record are the same as those which can be seen operating today.” And a similar statement is found in the equally influential Labov (1981) (“Resolving the Neogrammarian controversy”).

Though noticeable attention was paid both to the definitions and to the discussions provided by Labov on the subject of uniformitarianism in the set of publications just mentioned, the most salient fact about general reactions to Christy’s (1983) short (xiv + 139-page) book on roughly the same topic in its historical dimension was that much of his audience seems to have ignored the circumscribed focus stated explicitly in Christy’s title. At least among diachronic (as well as synchronic) *linguists*, that is, there apparently have been many readers who have assumed that Christy’s monograph on *Uniformitarianism in Linguistics* was – and still is – essentially a comprehensive treatment of uniformitarianism in every relevant field, including geology and biology. Yet Christy’s (1983) study, a revision of his Princeton University Ph.D. dissertation from 1982, actually has (reflecting its origins) an extremely narrow scope. The two nearly exclusive foci of Christy (1983) are, namely: (i) the geology of the nineteenth century and bordering decades as the idiosyncratic uniformitarian Lyell, his contemporaries, and his later hagiographers saw it, and him(self), and (ii) the paths by which the general concept of uniformitarianism first found its way from geology and (to a lesser extent) also biology into linguistics and then became established in the latter field, especially among the Neogrammarians. Because of its temporally truncated, excessively personalized (Lyellian), and thus myopic view of geology (lacking even glancing mention of numerous relevant studies on uniformitarianism which were available before 1982), the quite brief monograph in question has had the unfortunate effect of allowing diachronicians of language in particular to deprive themselves of access to works presenting a much truer picture of a major concept in their own and neighboring fields.

Admittedly, the background issues here – which involve at least partly the union as well as definitely the entire intersection between and among linguistics, geology, and biology – are quite complicated: to stay abreast of developments in three fields both diachronically (in terms of prior and ongoing historiography) and synchronically (in terms of current theory and practice) is probably beyond the capacity of any one individual. Nor do we wish to downplay Christy’s (1983) achievement in combing numerous mainly nineteenth-century sources in order to establish which specific scholarly and personal connections were most probably responsible for allowing uniformitarian ideas to percolate so rapidly from geology (and biology) into linguistics. Yet certain other comparisons are difficult to avoid. For example, Wells (1973: 424) – to whom Christy

(1983) refers – dissects several inconsistencies inherent in Lyell’s remarks on uniformitarianism, reviews the related geological and other literature, and concludes that, in essence, “Lyell himself was not an out-and-out uniformitarian.” Christy (1983), however, mentions three earlier works – by Hooykaas (1959, 1970) and Gould (1965) – which explicitly and cogently argue that Lyell’s only novel uniformities were not methodological and solid, but theoretical and seriously flawed, and yet Christy fails to discuss these findings (also repeated in other roughly contemporary works), but instead touts Lyell’s theoretical proposals (one of which Lyell ultimately abandoned) as being what sets him above and apart from his predecessors.

It is true that Christy (1983) gives a definition for uniformitarianism that is arguably more productive than those (quoted above) provided by Labov (1972a, 1974/1978), since Christy avoids any phrasing of an excessively, unnecessarily restrictive sort which would basically prohibit the positing of entities or processes for the past which are not observable today. Instead, for Christy (1983: ix), the principle in question has more to do with the fact that “knowledge of processes that operated in the past can be inferred by observing ongoing processes in the present.” This is essentially the “independent motivation” variety of uniformitarianism discussed near the start of the previous section: what is observed in the present can be proposed for the past, but what is not observed in the present cannot simply be banished, *ipso facto*, from the realm of the possible for the past. Labov (1994), however, keeps pace with shifts of thought in geology (thus citing Gould 1980 on Bretz 1923; cf. also Baker and Nummedal 1978; Baker 1981), adopts this geological consensus which had come to the fore since his last (1972a) book, and therefore thoroughly revises his earlier views by redefining uniformitarianism in Christy’s terms. For Labov (1994: 21), that is, the relevant principle states that proposals regarding the past are to be seen as independently motivated if they invoke processes known from the present. Yet, although Christy’s (1992) paper was presented at a 1989 conference that not only followed Christy’s (1983) book by six years but also was attended by some of the authors whose past and present research runs counter to his conclusions about the notions of uniformitarianism – and catastrophism – held in geology before, during, and after the time of Lyell, there is no mention in Christy (1992) of these scholars’ insights, even as claims.

The essence of this situation can perhaps best be expressed by means of a geological/geographical metaphor, and so we contend that the upshot of the above considerations for diachronicians (and synchronicians) of language is roughly as follows. In brief, taking Christy’s (1983) *Uniformitarianism in Linguistics* as one’s main or even sole source of information on the nature of uniformitarianism in geology (especially pre- and post-Lyell, but even *apud* Lyell) would be like mistakenly believing that a suspension bridge which linked the two rims of the Grand Canyon would constitute the entire US state of Arizona. Arizona indeed bills itself as “The Grand Canyon State,” and the Canyon itself is of such monumental depth and breadth that any bridge over it (we hasten to add that there is no such bridge at present, nor do we

favor the building of one) would truly be a marvel of engineering. Yet, relative to the entirety of both the Kaibab and the Coconino Plateaus, which it separates, the Grand Canyon is not large; compared to the whole rest of Arizona, the Canyon is anything but grand. Just as obviously, then, one short monograph on how an idea was transmitted from those who promoted it in earlier nineteenth-century geology to those who perceived, received, and reconceived it in later nineteenth-century linguistics does not even sufficiently exhaust the relevance of nineteenth-century geology for linguistics (whether historical, historiographical, or otherwise), let alone pre- and post-nineteenth century geology, and nineteenth-century geology as it existed apart from propaganda and hagiography.

1.2.2.2 *On living with catastrophes – and toward informational maximalism*

In this regard, one striking note of geological continuity – or at least resonance – that has potentially great relevance for diachronic (as well as synchronic) linguistics is provided by the way in which the non-religious catastrophism which had prevailed before Lyell (1830–3), even though driven underground by the latter's gradualistic uniformitarianism, today has a contemporary parallel in modern "neo- (or: new) catastrophism." Because it refutes uniformity of rate (or effect), this trend has been particularly stressed (as already indicated above) by Labov (1994: 21–3), who refers to the above-mentioned Gould (1980) and Bretz (1923) precisely for their discussions of how the so-called channeled scablands of Eastern Washington were carved out by repeated instances of "a single flood of glacial meltwater" which had "violent effects" when "vast volumes of water [were] suddenly released." It is examples like this which have sounded the death knell for versions of uniformitarianism that refuse to countenance proposals involving processes which are posited for the past but which have never been observed in the present (or during recorded history). As we have previously mentioned in connection with a number of issues, this older viewpoint – with its "if we don't see it now, then it never happened before" perspective – is now generally seen by geologists as being excessively restrictive on theoretical as well as on empirical grounds; cf., for example, Baker (1998).⁴²

As regards the empirical evidence in question, the proponents of the new catastrophism have so far collected a host of dramatic examples that have, by and large, been found convincing. (The catastrophes proposed in connection with certain extinctions, however, have been more controversial: cf., e.g., Alvarez et al. 1980, Raup 1986, and Alvarez 1997 on asteroids as the possible nemesis of dinosaurs.) We will here cite only two general types of what could be called "neo-examples of paleo-catastrophes," but all of the relevant cases are quite dramatic. The first such case involves comparing recorded versus unrecorded events in the behavior of volcanoes. On the one hand, some notable instances of volcanic activity have been witnessed and recorded – and thus can be considered to be part of a "present" that is available to anyone

invoking strict uniformitarianism as a guide to the past. This was the case, for example, with the Mt St Helens eruption in Washington state during 1980, and with the Tambora and Krakatoa eruptions in Indonesia during 1815 and 1883, respectively. Yet, as stressed by, for example, Decker and Decker (1998: 514; see also *Encyclopedia Britannica Online* 1994–2000) in a recent discussion of “Volcanism” exemplified partly with reference to the western United States, it is clear that “civilizations have never been tested by a cataclysm on the scale of the eruption at Yellowstone about 2,000,000 years ago; that eruption involved nearly 3,000 cubic kilometres of explosively boiling magma.” In short, the two observed eruptions in question ejected far less magma (from Krakatoa only some 18 cubic kilometres; from Tambora still just some 50–100 cubic kilometres) than did the prehistoric volcanic activity at issue – whereby it must of course be noted that the ancient eruption has been totally inferred from the geological record precisely because it was not witnessed.

Furthermore, according to the widely accepted “Big Bang” theory of the origin of the universe (cf., e.g., Weinberg 1977), certain events took place in the first few seconds or even picoseconds (billionths of a second) that have clearly not taken place in exactly that way at any time since, even though the unique events of this cataclysmic origin apparently do conform to natural laws as currently understood. Phenomena of this and the previous (volcanic) sort represent the kind of evidence which is now routinely adduced as showing the cogency of the neo-catastrophist conclusion that, in the concise but eloquent phrasing of Gould (1980: 201): “uniformity of law [across time and space] does not preclude natural catastrophes, particularly on the local scale . . . [;] some invariant laws operate to produce infrequent episodes of sudden, profound change.”

Moreover, the intervals between recurrences of even non-catastrophic but lawful phenomena can be so extended that the recurrent events in question have not yet occurred before the eyes of modern-day scientists. Therefore, glibly saying that the “present is the key to the past” does not excuse us from defining precisely what we mean by “present.” Clearly, not all phenomena occur at all times (just as they do not occur in all places – and certainly not simultaneously in all places!). Rather, in stating that the present is the key to the past, we intend “the present” to signify “the period during which scientifically accurate and explicit records have been kept.” Still, once we concede that this is what we mean, we thereby also admit that the relevant period is of comparatively brief duration – regardless of whether it is thought to have started during the lifetime of the Renaissance physician (and alchemist) Paracelsus (1493–1541) or of the Sanskrit grammarian Pāṇini (c.500 BC) or even of some Paleolithic painter drawing animal shapes on a cave wall (c. 14,000 BC) near what is now Altamira, Spain. That is, no matter how we calculate the length of time “during which scientifically accurate and explicit records have been kept,” we effectively are forced to concede that neither in language nor in geology have all possible types and magnitudes of phenomena necessarily occurred before our eyes.

Gould (1998: 211) has made this very point in a particularly succinct and apposite way (cf. also Wells 1973: 424) by writing that:

[to] regard nature's laws as invariant in space and time . . . [is] to articulat[e . . .] a general assumption and rule of reasoning in science . . . [, but it is] false . . . [to] extend such a claim to current phenomena (rather than universal laws) . . . [; then,] we surely go too far. The present range of observed causes and phenomena need not exhaust the realm of past . . . [ones].

Yet, by constraining themselves to use only the present in order to explain the past, some linguists have done exactly what Gould cautions against. In particular, instead of assuming that whatever occurs now is independently motivated and is thus available to be invoked in order to explain the past, even an old hand at historical linguistics like Lass (1978) instead once chose to adopt a struthious viewpoint – that of an ostrich – which in effect really does say that, “if we can't see something now, then it couldn't have existed then.” This kind of claim (which suggests that nothing can be postulated that has not yet been seen) may seem to be so extreme that no right-minded diachronician could ever have even implied it, but cf. Lass (1978: 274): “If we adopt a ‘uniformitarian’ view of language history . . . , then what we can reconstruct is . . . limited by our empirical knowledge of things that occur in present-day languages.” And Lass (1978: 277) is even more adamant: “If we reject the binding force of uniformitarian principles on the content of history, then we reject all interesting history” (for a less extreme view of uniformitarianism, however, see Lass 1997). The approach taken by Lass (1978) and certain like-minded scholars admittedly is quite wonderfully constrained, but this virtue does not compensate for its inconsistency with modern science – which, after all, has deposited promissory notes for many kinds of initially unobservable (and many still unobserved) constructs. There simply is no absolute basis for forbidding all hypotheses regarding unobserved elements in either a spatial or a temporal dimension.

Digging so deeply below the surface, in either linguistic or geological bedrock, is not very common among diachronicians of language, but our doing so here serves to show that an accurate summary of most discussions of uniformitarianism by historical linguists over the past two decades is quite reminiscent of a line from a short story by H. H. Munro (“Saki”) (1924): “A little inaccuracy sometimes saves tons of explanation.” Perhaps this strategy lies behind Lass's (1980) apparent exaggerations in favor of positing for the past only presently observable phenomena. Perhaps, too, it explains why Lyell has gone into so many older histories of geology (and biology), and even into newer introductory textbooks, right up to the present day, as an essentially error-free warrior-hero of science who vanquished ignorance and conquered religiously inspired anti-scientific prejudice – with not a word about his exaggerations of uniformitarianism or his creationist beliefs. These virtual hagiographies, in turn, clearly dominate the view of geology presented in the

most-quoted monograph on uniformitarianism in linguistics, Christy (1983) – whose almost exclusive focus on Lyell’s own self-servingly (if unintentionally) misleading blend of substantive and methodological uniformitarianism has not served to enlighten linguists either about language change or about pre- and post-Lyellian geology. For example, there were histories of geology (and biology) available long before 1982–3 whose discussions of the relevant issues would have helped avoid the canonization of Lyell (and the turning of the catastrophist Cuvier into a veritable scapegoat); cf. Davies (1969: 218):

Lyell and his disciples were mistaken in their belief that earth-movements have acted incessantly and with the same intensity throughout geological time, and their opponents, with their theory of catastrophes alternating with periods of calm, came closer to the modern conception of Earth-history as a series of orogenies [cases of mountain formation] separated by periods of quiescence . . . [T]he sole mistake of the catastrophists was to regard the earth-storms as sudden cataclysms occupying a period to be measured in days rather than in the millions of years demanded by modern geology.

(This passage once again anticipates our discussion of punctuated equilibrium in sections 1.2.3.4 and 1.2.3.5 below.) Here, we would only add that a more positive picture of Cuvier (though by no means a whitewash) emerges in such works as Coleman (1964), Outram (1984), and Rudwick (1997).

Admittedly, we may not be typical in our enthusiastic reaction to accounts of geological (and biological) controversies like those in Davies (1969), Rudwick (1972), Mayr (1982: 375–81, 875, 881–2n.9), and Gould (1987). Still, we personally find these to be nearly as gripping as detective stories, and we urge linguists – particularly all students of language change – to read such works, and also to read collections of original geological classics like those in Albritton (1975), rather than consulting only sanitized summaries written at one or two removes. It is apparently only in this way that certain misleading ideas about uniformitarianism can be avoided. First, there are a number of writers on linguistic topics from the mid-nineteenth-century and before whose verifiably uniformitarian leanings tend to be neglected;⁴³ for discussion, see especially Aarsleff (1982), Naumann et al. (1992), and Janda (2001: §8). Second, neither Lyell nor his close predecessor Hutton (1788, 1795) nor the latter’s devoted apologist Playfair (1802) can by any means be considered the originator of the concept of uniformitarianism; crucial in this regard is Aarsleff’s (1979: 316) observation that:

[i]t is characteristic of the history of ideas . . . , [and especially] of its weakness, that it does not find th[e] . . . principle [of uniformitarianism] until the word had been created . . . around 1840. But there is an analogue in the early seventeenth century in the discussion and controversy that followed Galileo’s writings on Jupiter’s moons, on the surface of the moon, etc. Indeed, the rejection of the hierarchical Aristotelian universe (with its fixed spheres, etc.) marks the assertion of a uniformitarian view of nature.

Given that Aarsleff is thanked by Christy (1983: vi) for “invaluable advice” during the writing of that book, and that another of his works is cited by the latter author, it is puzzling that Aarsleff’s earlier (1979) comments about pre-Lyellians who advocated what was basically uniformitarianism long before that term was coined (by Whewell in 1832, it will be recalled) are not mentioned anywhere by Christy (1983). At any rate, we believe that it is crucial to emphasize that the list of pre-Lyellian uniformitarians (in either theory or practice) is extremely long, that it reaches back to the early 1600s and is more or less continuous through to Lyell’s time (and afterward), and that it is much more international (in the sense of pan-European) than one might expect.⁴⁴ In addition, Sober (1988), has recently emphasized the centrality of uniformitarian ideas in the scientific work of Newton (1687) and the philosophical work of Hume (1748): “Newton’s idea[s] implement . . . an Ockhamite principle of parsimony” (Sober 1988: 52–3), while “Hume gave prominent place to an idea he called the Principle of the Uniformity of Nature . . . [– i.e., across] space and time” (Sober 1988: 41). Since these facts were known even during Lyell’s lifetime (and since it is also evident that Lyell was strongly influenced by Newton), we find it almost incomprehensible that Lyell and Hutton so regularly receive credit as, so to speak, the father and the grandfather of uniformitarianism. Probably the main reason for this is that, as we have already emphasized repeatedly, Lyell (1830–3) blended together at least four kinds of uniformities, and so this may have made his proposals seem unique – although, as we have seen, this is ultimately not to his credit (a point which we take up immediately below).

A third point worth repeating here is that a truly large number of mid-to-late-twentieth-century geologists (and biologists) have emphasized that Lyellian uniformitarianism is *not*, despite that author’s best (albeit probably unconscious; cf. Gould 1987: 119) efforts, an indivisible monolith of a notion that inextricably combines uniformities of law, process, rate, and state. Gould (1987: 118) himself “single[s] out the work of Hooykaas (1959), Rudwick (1972), and Porter (1976)” as having first pointed out the cracks in the alleged unity of Lyell’s uniformitarianism, but Gould (1965) had also come to the same principal conclusion.⁴⁵

Closing the circle by returning to the subject of Aristotle’s blade in Ockham’s razor and using them to cut away an unnecessary entity, we can summarize both this and the previous subsection by saying that (in a strict sense) linguistics, geology, biology, and other fields with a historical component do not really have a uniformitarian *principle*. Instead, they have only a uniformitarian *theorem* – at least as revealingly expressed, we think, by a name like *informational maximalism*, which we discuss below. This unprincipled conclusion, so to speak, follows because the only two valid aspects of uniformity – uniformity of law and uniformity of process (which have misleadingly come to be associated more with Lyell than with his predecessors, who developed them) – are in fact both straightforwardly derivable from the familiar principle of parsimony (or simplicity). The other two principal senses of uniformity – uniformity of

rate (or effect) and uniformity of state (or configuration) – both of which are non-methodological and hence subject to empirical (dis)confirmation – are both demonstrably false in the general case, though we must concede that gradualness is not infrequently found in particular cases (yet once again, cf. the subsequent discussion of punctuated equilibrium in sections 1.2.3.4 and 1.2.3.5).

It is a good sign for historical linguistics that the majority of discussions which specifically treat uniformitarianism tend to focus primarily on uniformity of process (introduced above as an independent-motivation-related criterion) and only secondarily on uniformity of law (introduced above as a more directly parsimony-related criterion whereby two sets of laws – each for a different time – are clearly inferior to one set of law holding for all time(s). In such works, uniformity of rate tends to receive little, if any, (tertiary) attention, while uniformity of state is hardly heeded at all. Thus, for example, Collinge's (1994b: 1561) remarks on the historiography of historical linguistics single out uniformitarianism as a "desirable . . . controlling subtheory" for Neogrammarians like Osthoff and Brugmann (1878), who reasoned that (in our adjustment of Collinge's translation) "the psychological and physiological nature of [hu]man[s] as speaker[s] must have been essentially identical at all epochs" (here, intriguingly, we seem to be on the border between the uniformities of law and of process).

In dealing here with the nexus of issues usually discussed together under the Lyellian rubric of *uniformitarianism*, we have so far avoided proposing any new names for specific senses falling under that umbrella term – though we have suggested that the "u . . . word" itself be dropped, partly because it does not represent a basic principle, anyway, but just a theorem derivable from the principle of parsimony (i.e., Ockham's razor and Aristotle's blade). We should mention, however, that some scholars have dispreferred *uniformitarianism* on such grounds as the fact that this term would also apply to a universe which showed uniformity because every event was controlled by the intervention of divine whim (cf., e.g., Mayr 1972/1976: 286). On the other hand, there are also difficulties with the related proposal to give *uniformitarianism* the alternative name *actualism* on the grounds that the principle's main force is that the present is the key to the past. As has already been discussed above and elsewhere (cf. Janda 2001: §8), the main reason for mentioning the present in connection with the study of the past is that the present is the time about which we normally can gain the most information. But this is not a necessity; an unfortunate conjunction of industrial accidents, environmental problems, political turmoil, and arbitrary, dictatorial governments could cause it to happen that, at some point in time, more information was available (and could be gathered) about language use at a recent past time than about speech in the present.⁴⁶ Hence the term *actualism*, we would claim, actually suppresses the crucial fact that the present is important to the study of the past, not simply because it is the present, but because it is the time at and for which the greatest amount – and the greatest variety – of information is normally available.

To a great extent, then, what we should really strive for, in diachronic pursuits such as historical linguistics, is what could be called “*informational maximalism*” – that is, the utilization of all reasonable means to extend our knowledge of what might have been going on in the past, even though it is not directly observable. Normally, this will involve a heavy concentration on the immediate present, but it is in fact more realistic just to say that we wish to gain a maximum of information from a maximum of potential sources: different times and different places – and, in the case of language, also different regional and social dialects, different contexts, different styles, different topics, and so on and so forth. We can recall here the hypothetical situation discussed at the start of section 1.2.1 above, where we listed two alternatives involving very different collections of information about the same event: on the one hand, a few still-life photographs of an eroding hillside; on the other hand, a series of time-lapse photographs of the same “event.” What time-lapse pictures do, of course, is to maxim(al)ize the available information in comparison with just a few random snapshots, and we would suggest that it is the sworn duty of every kind of historian – of language, of natural events, or of (non-linguistic) human acts – to exploit any ethical means available in order to reach such an information-maxim(al)izing goal. (We should consider renaming this approach, however – and thus think about calling it “*informational maximality*” – if we want to avoid any negativity that might tend to accompany words ending in *-ism*.)

Now, uniformitarianism in some of the senses discussed here – most profitably following Gould (1987) and similar-minded others – can be a remarkably powerful and beneficial tool in this pursuit of maxim(al)izing information. For example, it sometimes brings a vigorous breath of fresh air into diachronic investigations when a researcher suddenly says, as Glassie (1968: viii) did about historical studies of folklore, “We . . . have talked too much in the past tense . . . [;] our methods have been too few, our fields of investigation too limited.” And issues centering on issues of uniformitarianism – both pro and con – have recently invigorated debates among historians of family life as to whether and when families in earlier times lived their lives in ways (e.g., regarding child-rearing) that were basically different from the practices of our own time.⁴⁷ Indeed, discussions concerning how studies of earlier times by present-day scholars should best be carried out – and how students can most effectively be instructed about the past, even if they do not later intend to become diachronicians of any kind – quite commonly center on uniformitarianism-related issues.⁴⁸ But there are certain other senses of *uniformitarianism* that can turn this principle into a straitjacket which hinders the formulation of reasonable hypotheses about the past and about the why and how of change. Let us therefore now cease any and all uninformed tarryin’ in *-isms*, and thus turn back now to a (re)consideration of the basic object under scrutiny here – change itself – all the while attempting to maxim(al)ize the amount of relevant information about it which we can efficiently assemble and concisely present.

1.2.3 *Change revisited*

The description of a language is not achieved through taking apart all the elements of its delicate machinery any more than a watch would be usefully and exhaustively described through the linear display on a green cloth of all its springs and cogwheels. It is necessary to show how all the elements of both the language and the watch cooperate when at work. Anatomy, unless studied with a view to accounting for physiology, would amount to some sort of “necrology” or corpse-lore of little use or interest to anybody except perhaps professional embalmers. So far we have had, in . . . linguistics, a little too much anatomy and not enough physiology, and the rigor after which some of us are striving too often resembles rigor mortis. But no analogy is fully satisfactory. . . . In the case of languages, observation will show, not only how they function today, but also how the ever changing and conflicting needs of their users are permanently at work silently shaping, out of the language of today, the language of tomorrow.

André Martinet, “The unity of linguistics,” *Word* 10.2–3 (1954: 125)

What model will ever catch process? . . . [A] history that claims . . . realism must surely catch process – not just change, but the changing, too.

Greg Denning, *Mr. Bligh’s Bad Language: Passion, Power and Theatre on the “Bounty”* (1992: 6)

Most if not all works on language change which are known to us take the concept of change essentially for granted. Their reasons for doing so may well have something to do with the difficulty of precisely and accurately characterizing the relevant notion. Take, for instance, one philosopher’s definition – that of Bertrand Russell (1903: 469 [S442]):

Change is the difference, in respect of truth or falsehood, between . . . [(1)] a proposition . . . [P] concerning an entity . . . [X] and a time T and . . . [(2)] a proposition . . . [P'] concerning the same entity . . . [X] and another time T', provided that the two propositions . . . [P and P'] differ only by the fact that T occurs in the one where T' occurs in the other. . . .

For Russell, that is, an entity X can be said to have changed between times T and T' if some proposition concerning X is true at T but false at T', or vice versa. Significantly, this much-discussed definition does not require the two relevant times T and T' to be chronologically adjacent, and so it apparently permits use of the term *change* with reference to diachronic correspondences between states which are temporally quite distant from each other: say (to take a linguistic example), between reconstructed Proto-Indo-European (PIE) c.5,000 BC versus present-day Modern English in AD 2000.⁴⁹ But Russell’s (1903) account of change was soon directly challenged (along with much previous philosophizing about time in general; see here section 1.3 below) by J. M. E. McTaggart’s arguments to the effect that, since change crucially involves time, but “nothing

that exists can be temporal," then "time is unreal," and so change does not exist, either (1908: 457).⁵⁰ In response to McTaggart's provocative claims, a defense and clarification of Russell's approach to change (though not to time in general) was later provided by C. D. Broad (1938). Broad more explicitly narrowed the sense of his definiendum in ways which strike the present editors/authors as more conducive to explaining change(s) in language – as long as we take "change" here to collapse the distinction made between (*individual*) *innovation* and (*group-wide*) *change* in section 1.2.1 above. That is, Broad's account is more centrally focused on spatiotemporal and causal connectedness – and hence on differences which, for language, could arise within a single speaker's lifetime (1938: 297):

There are certain series of successive events . . . such that the members of any one such series are intimately interconnected by . . . [particular] spatial, causal, and other relations, which do not interconnect members of any two such series. Each such series is counted as the history of a different thing. Now successive members of one such series may differ in respect of a certain quality; e.g., one term may have the determinable quality Q in the determinate form q_1 . . . [, while] . . . a later term may have Q in the form q_2 . The statement "The thing . . . [X] changes from q_1 to q_2 " is completely analyzable into a statement of the . . . kind . . . "There is a certain series of successive events so interrelated that it counts as the history of a certain thing [X] . . . ; e_1 and e_2 are two successive adjoined phases in this series . . . [,] and e_1 has Q in the form q_1 . . . [, while] e_2 has Q in the form q_2 ".

In the time since Broad wrote the foregoing, the already considerable philosophical literature on change has grown truly massive (but cf. the ancient-to-modern historical surveys given in brief by Čapek 1967 and Turetzky 1998 or at length by Strobach 1998). Still, we assume that an updated general account of the above sort (as most cogently explicated by Mellor 1998: 70–2, 85–96, 98–100, 115–17 et passim; Strobach 1998; and their most recent references) will be adequate for the purposes of this introduction (and in fact as a background for all the chapters in this volume, just as each author implicitly assumes). Hence the main remaining issue to be addressed here concerns what can be viewed as the difference between change(s) in a token versus change(s) in a type. This distinction is particularly relevant for historical linguists, as is evident from the amount of discussion devoted to its ramifications in the following subsections. But the same difference often arises in everyday life.

For instance, if someone begins a conversation or discourse by saying, "*That dog has changed a lot since I last visited your breeding farm,*" this ambiguous start might be continued either with "*– it's full-grown now*" (revealing that a dog in a specific sense is being discussed) or with "*– the spots have been bred right out of it*" (revealing that a breed of dog in a generic sense is at issue). In this case, saying that one particular dog has changed involves a report on a comparison made across two different temporal states of a single concrete entity, but saying that a breed of dogs has changed requires a comparison made across a series of different entities (associated with two at least partly distinct times) which

are still taken to (help) constitute earlier and later states of one abstract entity. Latent here, of course, is the question of species as realities versus abstractions – an extremely vexed complex of issues in biology beyond our ability to do justice to here (but see Wilson 1990).⁵¹

Hence, after this broad but rapid pass through the general issues involved in defining both change and what changes, we now return to specific issues of linguistic change.

1.2.3.1 Processes of change versus accidental gaps in the historical record

With regard to the phenomenon of change itself, we would argue that anyone who wants to understand the mechanisms by which change takes place – in language or indeed in any happenstance or activity or event – must (i) find two well-attested different states which are as close together in time as possible and (ii) learn as much about each one as is humanly possible, since this provides the best basis for determining the nature of the transition between them.⁵² Most of the time in historical linguistics, however, we have one stage about which we know little and another stage about which we know even less. In such (myriad) cases, one may well ask whether the study of language change is a reasonable or even a possible endeavor. Of course, we can try to make a virtue of necessity, and so rejoice in the fact that extremely limited bases of comparison of this sort – with two fragmentarily attested stages – prevent us from being overwhelmed by data (recall the discussion in section 1.2.1.7 above). But the extensive filling-in which this approach unavoidably entails can lead diachronic linguists to reconstruct direct continuities in places where the actual history of a language may well have included many abandoned offbranchings, or even a succession of extremely similar dead ends. As that inimitable giant of Romance historical linguistics, the late Yakov Malkiel, once put it (1967: 149):

[N]ot only does the actual progress of research fail to follow a straight line, but the development of language itself . . . reveals, on microscopic inspection, a number of . . . sharp curves and breaks . . . [,] an angularity which, as a rule, only in long-distance perspective yields to the soothing image of straight, beautifully drawn lines.

Bynon (1977: 6), on the other hand, has talked of “an optimal time-lapse” of some “four or five centuries” between the two linguistic states being examined. She reasons that this “is most favorable for the systematic study of change . . . [,] the differences between successive language states are then sufficiently large to allow the statement in the form of rules of completed changes . . . [,] yet continuity is not at stake – one is clearly still dealing with ‘the same language’.” (Or is one? See both above and below for further discussion of this notion of “sameness.”) Related to this is Bloomfield’s (1933: 347) assertion that “the process of linguistic change has never been directly observed; . . . such observation, with our present facilities, is inconceivable.”⁵³

Still, as Labov has forcefully argued, with regard to what he first documented on Martha's Vineyard and has repeatedly seen confirmed since (see chapter 8 by GUY): "the mixed pattern of uneven phonetic conditioning . . . [with] shifting frequencies of usage in various age levels, areas, and social groups . . . is the process of linguistic change in the simplest form which deserves the name" (1963: 293). In short, overall processes of linguistic change are not unobservable. Indeed, it was already the case in the early 1960s that the particular changes involving diphthong centralization by English-speakers on Martha's Vineyard (e.g., in *knife* and *house*) had been documented first-hand (via several kinds of recordings: audiotapes, spectrograms, tables or graphs, phonetic transcriptions, and the like). Yet even Labov's work on these data was based on inferences about change extrapolated by means of a comparison of Martha's Vineyard in the early 1960s with records from some thirty years earlier – that is, by looking at two chronologically close stages (for related discussion, see also chapter 24 by WOLFRAM AND SCHILLING-ESTES).

We thus learn about change from comparisons of various sorts. One approach performs "vertical"⁵⁴ comparison – that between different stages of a language – and so relies on the interpretation of documentation linked with some earlier stage(s), whether in a written form requiring more intensive philological analysis⁵⁵ or in some other form requiring less intensive analysis (e.g., wax recordings, tapes, movies, etc.);⁵⁶ from these sources, we extract inferences about change by looking at what is different between the two stages. But we can also perform "horizontal" comparison – that between related languages⁵⁷ – and so make inferences about change that rest on two crucial assumptions. These are, first, that all related languages must ultimately have arisen from a common earlier source (see chapter 4 by LYLE CAMPBELL) and, second, that finding mismatches in comparable items between the two languages implies that at least one change – and possibly more – must have taken place.⁵⁸ In either way, we can learn something about language change; in both cases, comparison is necessarily involved.

Actually, these observations point to a further complication, since it is far from obvious that the same object is really being compared in any intended vertical comparison between two of its different stages – this is the previously mentioned problem of type change versus token change. For one thing, a notion such as "English," even if it is temporally limited as, say, "twentieth-century English," and geographically further localized as, say, "twentieth-century North American English," is always (though see nn. 35, 36) something of a convenient fiction, a construct which allows us to proceed with analysis by suggesting cross-temporal uniformity but then, when minutely scrutinized, quickly breaks down. For another thing, even if we agree that we can talk in terms of "English of the twentieth century in North America" and compare it with "English of the eighteenth century in North America," will there really be something(s) to compare meaningfully?⁵⁹

For example, further arguments are given in the following subsection (see also chapters 7, 21, and 14 by HALE, BENJAMIN W. FORTSON IV, and LIGHTFOOT,

respectively) that it is valid to view the transmission of language over time as necessarily discontinuous, since the twin facts of birth and death of individual speakers require some version of the object “Language”/“language X” to be recreated anew within each individual as she or he helps define a new generation. But, in that case, seeking the continuity that is needed for cross-temporal comparisons may often or even always be in vain. Rather, we must recognize the social fact that, as the members of each identifiable generation recreate language for their own use, language is continuously being integrated into a society that is not uniform in terms of age but still takes in new members seamlessly from new entries into it (i.e., new individuals). Thus, the social dimension of language must be a crucial ingredient in any attempt to provide some sense of the continuity that exists, overall, throughout the history of a language.

To take yet another tack, though: Is “English” as instantiated in one individual necessarily the same as “English” as instantiated in another? If not, will a valid cross-temporal comparison ever be possible? The question of asking whether “English” as an entity covers Old English, Middle English, and Modern English is thus akin to the issue of considering whether the “New York Yankees” is/are an entity that covers both the 1927 instantiation and the 1998 instantiation of that team, even though all that is the same is the “corporate” being – the “Yankees” as an abstraction. On a more personal level, given that most of the cells in a person’s body are completely replaced within a certain number of years (seven, according to one tradition of folk wisdom), is there any real sense in which we can consider ourselves to be “the same” individual at different stages of our life? It was a negative response to this kind of query that apparently induced the Ancient Greek philosopher Heraclitus to make his famous statement that “you can’t step twice into the same river” (cf. section 1.2 above), but the basic question here at issue was not just asked but also answered more than a century ago by the physical scientist and writer John Tyndall (1897: 50–1):

Consider . . . personal identity . . . in relation to . . . molecular form . . . [.] the whole body . . . wastes . . . , so that after a certain number of years it is entirely renewed. How is the sense of personal identity maintained across this flight of molecules? . . . Constancy of form in the grouping of the molecules, and not constancy of the molecules themselves, is the correlative of this constancy of perception. Life is a *wave* which in no two consecutive moments of its existence are composed of the same particles [original emphasis].

This same phenomenon is, if anything, even more characteristic of the way in which speakers view their languages as maintaining diachronic coherence and essential identity in the face of constant variation and change. In fact, one historical (and general) linguist, as brought out in the next subsection, has even gone so far as to claim that “[l]inguistic change does not exist,” and he seems to be right – if not in every sense, then (as the following discussion shows) in at least one sense of *change*.

1.2.3.2 (Potential) type immortality via a discontinuous series of mortal tokens

Most linguists, we think, would agree that an individual person's language is more than the totality of sentences that he or she has ever uttered – or will ever actually utter – since an infinity of possible sentences always remains unsaid. It therefore makes sense to identify a person's idiolect with the neurologically instantiated cognitive system(s) allowing him or her: (i) to use and understand language, spoken or signed, and (ii) thereby to follow or flout the group- and community-norms of his or her surroundings.⁶⁰ In this sense, the birth of a new linguistic pattern correlates with the moment of its initial cognitive adoption, not with its first application in speech. Even more linguists, we are confident, would agree that speakers are mortal – from which it follows that cognitively realized linguistic systems exist, on average (depending on the conditions of life at any given place), for less than 100 years, with many enduring less (often, alas, much less) than the biblical three score years and ten: 70 years. But particular (sets of) speech-patterns used by older speakers can exceed these temporal limits of human mortality, because communities are continually replenished by the births of younger speakers willing and able to replicate some version of such patterns.

Yet, in terms of Tyndall's (1897) above-mentioned distinction, this chain of generations is interlinked not by "constancy of the [same neural] molecules [of grammar] themselves," but by "constancy of form in the grouping of . . . [different] molecules" – or even more abstract entities – of grammar. For example, in cases where historical linguists tend to say that *a* "becomes" *a'* (commonly abbreviated as *a > a'*), it really is not completely accurate to substitute a description in which *a* "is replaced" by *a'*,⁶¹ rather, it is most revealing to characterize such cases by saying that, after a time when (only) *a* is used, *a'* is introduced and varies with *a* – until *a* no longer is used, but only *a'*. Given this, there follow certain conclusions as to the nature of language and change; it was Coseriu (1982: 148) who pursued these latent implications to their most drastic but most rigorously logical extreme, contrasting *dínamis* (Classical Greek for 'power, ability, faculty' – thus here, 'system of procedures') with *érgon* (Classical Greek for 'work, deed,' thus here, 'product'):

The actual problem of linguistic change viewed from the standpoint of . . . language as a creative activity can best be understood . . . if we start from the assumption that linguistic change "does not exist" . . . [T]here are three ways in which what has been called "linguistic change" does not exist: first, it does not exist as a modification in an "object" conceived of as being continuous, as a process of change in external phenomena (as, for example, *a > e*); second, it usually does not exist for the speakers of a language, who normally are convinced – so far as their own activity is concerned – that they are continuing a linguistic tradition without change . . . [and] third, it often does not exist in the language . . . as a system of procedures, but rather only in language . . . as a product of already given procedures of . . . language, which as such do not become different.

Coseriu's third point appears to be the least controversial: regardless of whether use of a novel speech-pattern is characteristic of an entire community or of only one individual, an insightful analysis will recognize (as argued above) that the origin of such a pattern almost always lies earlier in time than the moment(s) of its first utterance.⁶² For example, one of the authors (Janda) recalls that, when he first heard someone pronounce the past tense of *speedread* with ablaut in only its second element (as [spɪdrɛd], his reaction was to wince. This was because he suddenly realized, for the first time, that his own analysis of this verb involved a quasi-serial structure which would require him to say double-ablouted *speedread* ([spɛdrɛd]), even though he had never heard this (innovative?) past-tense form before and in fact did not have any occasion to utter it himself until much later.

Coseriu's second sense in which linguistic change is non-existent has been challenged by proponents of the view that some (especially older) speakers do become aware of the directionality and change inherent in linguistic variation (cf., e.g., Andersen 1989, with whom we tend to agree), but nearly the identical conclusion had earlier been reached by writers like Bynon (1977: 1, 6).⁶³

[S]peakers for whom a . . . language serves as a means of communication are in general quite unaware of its historical dimension. . . . [B]ecause it is embedded in variation patterns current within the community, the process of language change lies for the most part outside of the individual speaker's awareness; pre-occupied with the social significance of alternative forms, . . . [most speakers are] largely unaware of their correlation with time . . . [Yet] the present state [of a language] is the only one which can provide . . . full information on all . . . phenomena, including . . . change.

This issue is far from being moot, in part because Labov (1972aff) has demonstrated that middle-aged adults often play a crucial early role in ongoing changes, due to their being incomparably more sensitive to the social ways of their community than are young children, and in part (as well as relatedly) because Labov and other variationists have taken the central ingredient of linguistic change to be an alteration of sociolinguistic norms. Obviously, too, if we grant the validity of Coseriu's (1982) first point, then innovations in a speaker's idiolectal grammar during his or her lifetime are left as the only possible kind of change in language: if such phenomena are rejected (as changes), then there is no escape from the conclusion that linguistic change does not exist. Yet it is such innovations in an individual's grammar over his or her post-acquisitional lifetime that most generative diachronicians have found least revealing (or, at any rate, least deserving of their attention). Let us thus turn to the issue on which, despite persistent criticisms from adherents of other approaches to diachrony, there seems to be the most agreement between Coseriu and earlier as well as more recent generativist historical linguists: the discontinuous transmission of language over time (the following discussion of which is expanded from Janda 2001: §3).

It is actually by no means unexpected that discontinuities of diachronic transmission should characterize a phenomenon like language, which shows

such relatively abstract patterning and is realized (whether in speech or in signing) by elements that, individually, are highly ephemeral. This is because even an entity with a more concrete nature and greater temporal staying power cannot survive for long on an absolute timescale unless it is recategorized as representing a more abstract type instantiated by a temporal succession of discontinuous physical tokens (for a musical parallel, cf. Hopkins 1980: 615–17 on French composer Maurice Ravel’s techniques for expressing the temporal extension of musical “objects” via strategies of movement as well as stasis). The point at issue can be illustrated with reference to a set of nineteenth-century train-car pictures employed – for other purposes, but with equal force – by the Swedish archeologist Oscar Montelius (1899: 260–3), who used the drawings here labeled figures I.1–4 (= figures 73–6 in his article) to exemplify his “typological” method for deriving a chronology of artifacts.⁶⁴ For example,

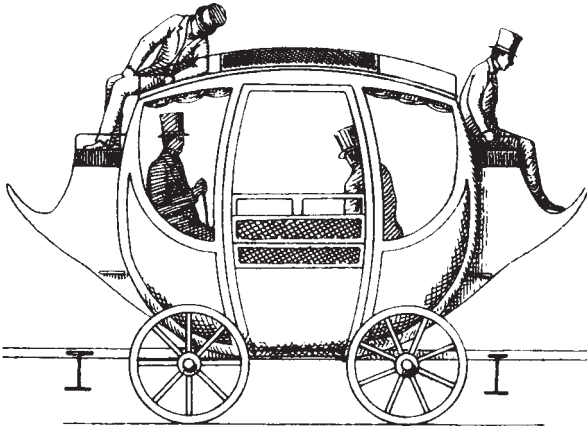

Figure I.1 Montelius’s figure 73: British, 1825: the first train-car for passenger transport

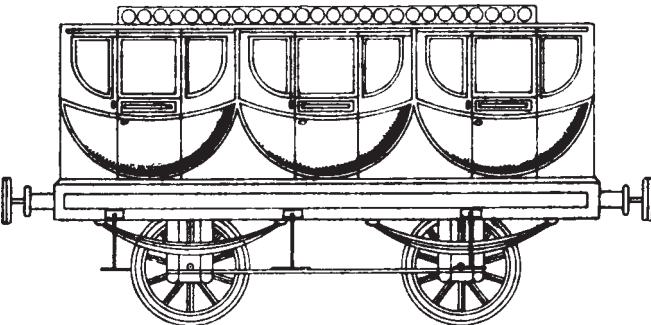

Figure I.2 Montelius’s figure 74: Austrian, 1840

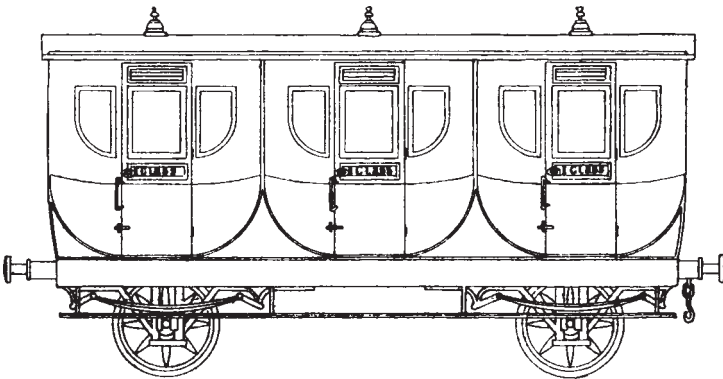

Figure I.3 Montelius’s figure 75: one of the first train-cars ordered for the Swedish state railways (made in Germany shortly after the mid-1850s): for first-class passengers

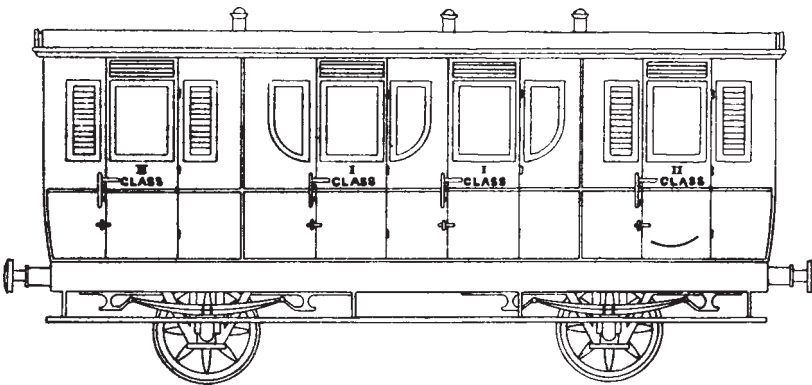

Figure I.4 Montelius’s figure 76: another of the first train-cars ordered for the Swedish state railways (made in Germany shortly after the mid-1850s): for first- and second-class passengers

given a set of objects whose respective properties are, schematically, (i) A, (ii) AB, and (iii) BC, this method would analyze these objects as having developed in that order – viz., (i)–(ii)–(iii) – that is, from lesser to greater overall complexity, and with formally intermediate items being medial in time. Now, such an approach is known to face certain problems of temporal ambiguity when it attempts to order prehistoric artifacts whose chronology is as yet unknown on other grounds.⁶⁵ But the development of European railroads is a historical development whose exact chronology is not in any doubt.⁶⁶ Hence there is nothing to prevent us from hijacking Montelius’ train-cars, so to speak, and focusing on the fact that a series of four distinct, discontinuous physical objects can here be viewed as four tokens that are

relatively constant in themselves yet, together, successively instantiate one overall type which is undergoing change (recall section 1.2.3 above on change, tokens, and types).

The type/token distinction is thus indeed crucial as regards discussions of change. That is, we might say (without any reflection) that the European train-car “changed in shape” from rounded to squarish between 1825 and c.1857, and we might even figuratively say that the carriage-like British train-car of 1825 “ultimately turned into” the squarish Swedish train-car of c.1857 – in both cases describing a type in terms of its earlier versus later tokens at the extremes of a timespan. But (unless railway parts underwent direct physical recycling in the 1800s) we cannot truthfully say that any particular English train-car of 1825, as a concrete object, “literally changed into” a train-car of 1840 (in Austria or anywhere else) much less that it “physically became” a Swedish train-car of c.1857. In sum, then, individual (tokens of) train-cars are not immortal, so to speak: they eventually disappear from railway traffic and must be replaced. Yet precisely the continuing construction of new (tokens of) train-cars, even with slightly different properties, allows the (type of the) train-car to survive longer than any one of its particular manifestations ever lasts on the job.

Hence, on this concrete, token-based interpretation, the train-car of an earlier era does not change into, but is instead replaced by, the train-car of a later era, and so a Coseriu of the rails could legitimately claim that, in at least one sense, “train-car change does not exist” – perhaps only to receive the answer that, in another sense, individual (tokens of) train-cars do in fact undergo some physical change over their working lifetimes. But a Labov of the locomotives could then point out that even a figurative, type-oriented approach – one which allows a train-car of one era to be described as changing into a train-car of another era – obscures the fact that, at any given time, there are likely to be several vintages of train-cars in use. For example, the working life of a train-car from 1840 might well have been so lengthy that such an entity could share the rails with a train-car built in c.1857, and perhaps even be pulled by the same engine. Even when relativized to a type, then, train-car change, too, surely can sometimes happen through variation due to overlap, not via periodic abrupt replacement of entire vintages of train-cars.⁶⁷

This kind of observation is worth emphasizing, because the present chronological sequence discussed by Montelius (1899) vis-à-vis archeology and here compared to linguistic change involves a persistent property – the curved, stagecoach-like windows flanking the central door(s) on every post-1825 train-car – of the sort sometimes said to require a “historical explanation,” as if such a retention could arise, or be repeated, in some way other than synchronically. The implication here is that the older window-style of train-cars built earlier must somehow have been held over into later train-cars by a quasi-physical inertial force. But this ignores the crucial fact of discontinuity. Newly produced train-cars cannot come to have old-style windows unless they were actively – that is, synchronically – designed and built with copies

of these; the only place where the motionless sort of inertia can keep old windows is on old train-cars. We can avoid the “historical explanation” trap and its invalid inertial reasoning, though, by recalling the above-mentioned variationist fact that at least some train-cars of an older vintage are likely to have been still in use (or at least vividly remembered) when new train-cars were planned – and in fact probably served as a model and motivating factor for the design of the latter. Since, at every moment, any given state represents either an identical continuation or else a changed version of some earlier state, and since both continuity and change can be viewed as aspects of history, it follows that everything in the universe must in some sense have a “historical explanation,” and so this concept simultaneously explains everything and nothing; cf., for example, Janda (1984: 103n.3).⁶⁸ It is much more useful, therefore, to consider psychological and sociocultural factors (such as conformity and accommodation) in seeking explanations for the long-term retention of some property across a type’s many successive, discontinuous tokens, whether these be train-cars or linguistic systems (i.e., grammars).

Still, in switching our focus away from how design features of conveyances for transporting humans are diachronically transmitted, and back to how human speech-patterns are passed along through time, there is one last (but far from least) parallelism to be noted. Namely, there can be certain periods during which virtually every newly constructed token of a type – either linguistic or rail-related – seems to resemble its predecessor model(s) so closely that no systematic (i.e., type-representative) trend of change in form is evident across such a chain of two or more members (although the latter will of course be physically distinguishable with reference to their non-systematic characteristics).

In the case of train-cars, this practically goes without saying, since it is normally much more profitable in manufacturing to build multiple exemplars of a successful product over several years (by making nearly exact copies of an only slightly varying prototype) than it is to construct one qualitatively unique (type of) ware after another. Thus, although the four train-cars discussed here following Montelius (1899) do indeed represent (regardless of the temporal overlap that they may later have shown) a chronologically accurate series when they are sequenced according to their date of construction and earliest use (first 1825, then 1840, and finally, twice, the mid-1850s), they do not actually form an unbroken chain – since, between any adjacent pair of these, there intervened many other tokens more nearly identical to the earlier model of the two. For instance, the manufacture of the 1825 train-car was followed, over the next several years, by the building of many similar conveyances that did not systematically differ from it. Besides, given that the use of assembly lines and of interchangeable parts was not common until after about 1855, repeated manufacturing of “the same train-car” tended to involve taking the most recently built train-car as a model for creating its successor more than it did the cookie-cutter-like turning out of identical train-cars literally from the same mold(s).⁶⁹

1.2.3.3 *Child-changed or not, language is always transmitted discontinuously*

But, just as it is not a mere possibility but a verifiable fact that, during some temporal spans, the physical features of train-cars were passed along discontinuously – from earlier to later tokens of that type – without *systematic* change, so do we also know that there continue to be times when the discontinuous transmission of a linguistic system's more abstract features too can take place without any *systematic* change – as opposed to idiosyncratic innovation(s). This kind of amazingly exact grammatical cloning (in the non-technical sense of the word)⁷⁰ is documented for cases of language transmission from an older to a younger generation like those reported by Labov (1994: 579), who mentions “children as young as three years old” who have near-identical matches with their parents for patterns of quantitative variation like English *-t/-d* deletion (cf. also Roberts and Labov 1995; Roberts 1997). These findings may seem innocuous on the surface (e.g., they surprise few non-linguists), but they have profound implications for synchronic as well as diachronic linguistics.

Most crucially, the fact that language can be discontinuously transmitted from parents to children without systematic change confirms what we asserted above: the main reason to assume discontinuous language transmission is that human life is bounded by natality and mortality. That is, the force obliging us to accept discontinuity is the (delayed) one-two punch of birth and death, not some misguided reasoning whereby the existence of linguistic change and a dearth of imaginable explanations for it somehow foster the desperate belief that only imperfect language acquisition can explain substantial linguistic changes over time. After all, language acquisition as part of discontinuous transmission need not involve systematic change, and (as stressed in the last section) socially motivated (group-oriented) change can be associated with an individual's adulthood – for example, when a lower-middle-class speaker in New York City brings to his most formal styles an off-the-scale frequency for a prestige variant (like “undropped” /r/ in syllable codas; cf., e.g., Labov 1972a: 160 et passim). This is, one might say, the linguistic equivalent of a train-car manufacturer's adding various new external panels, grillwork, and coats of paint to a train already in service for several years after the latter has been moved onto a route passing through up-scale neighborhoods.

Given our insistence on the reality of discontinuity, in language as well as in life (both being bounded by death), it is incumbent upon us to offer at least a sketch of a model suggesting how language is passed along over time, and where the primary locus (or loci) of change is (or are) likely to be, vis-à-vis the different stages of life and the various possible sorts of transmission. We discuss this topic at some length below, but first address a further implication of the fact that discontinuous linguistic transmission is not automatically associated with systematic change, especially during language acquisition in childhood. Namely, if the acquisitional accomplishment of overcoming the challenge of discontinuous transmission by achieving close copies of older speakers' linguistic

patterns can be repeated across a large number of generations before there is any major systematic change, then this situation might be considered a linguistic equivalent of the scenario known among evolutionary biologists as “punctuated equilibrium” (and mentioned here above in n. 17).

1.2.3.4 *Peripatric speciation of biologists’ “punctuated equilibrium” among linguists*

Though briefly discussed as an attested possibility by Haldane (1932: 22, 102) and anticipated above the species level by the “quantum evolution” of Simpson (1944: 206), the concept variously referred to as *punctuated equilibrium*, *punctuated equilibria*, or *punctuationism* gained prominence in current evolutionary biology due to the recent writings of two contemporary paleontologists. First (but as yet without new terms) came a short, low-profile journal article by Eldredge (1971), and then a long paper by Eldredge and Gould (1972) in the proceedings of a high-profile symposium. The perspective outlined in those works has been updated periodically by their authors: for example, in Gould and Eldredge (1977, 1993), Gould (1982, 1989, 1997), and Eldredge (1989, 1995, 1999), with the longest dedicated treatment being Eldredge’s (1985) book *Time Frames*, which is entirely devoted to – and hence subtitled – *The Rethinking of Darwinian Evolution and the Theory of Punctuated Equilibria* (but see now also – passim – Gould’s 2002 *The Structure of Evolutionary Theory*, especially pp. 745–1024). In the nearly three decades since its full-blown emergence, punctuationism has provoked critical reactions of varying severity and cogency,⁷¹ and these, in turn, have elicited very pointed responses from Eldredge and/or Gould. Others as well have contributed defenses and elaborations; as representatives of either or both of the latter, cf. Stanley (1975, 1979, 1981), Vrba (1980, plus Vrba and Gould 1986), Williamson (1981, 1985), Sober (1984/1993: 355–68), Cheetham (1986), Jackson and Cheetham (1990, 1994, 1999), and Schwartz (1999: 321–30, 354–7, 377–9), among others. In short, the topic of punctuated equilibrium has now achieved such a broad distribution across both the specialist and the generalist literatures on evolutionary biology and other disciplines that it could not do otherwise than eventually enter the consciousness of linguistic diachronicians. Still, as we discuss in this and the next section, the results of linguists’ dealings with punctuational matters include a heavy mixture of the vague, the misinterpreted, and the misleading, though we are convinced that a heuristic look at biological punctuationism suggests several largely corrective but nonetheless genuine insights – mainly of a sociolinguistic nature – which are of great value for the study of language change.

At issue in this general debate are a number of related punctuationist claims; a convenient statement summarizing the biological core of these is provided by Eldredge (1999):

[T]he bulk of most species’ histories are marked by stability (... little or no accumulation of anatomical change) ... [Thus,] most ... change in evolution, assumed to be under the control of natural selection, occurs ... in conjunction

with the actual process of speciation, which for the most part occurs through . . . geographic variation and isolation. (p. 22)

[S]peciation – the derivation of two or more descendant species from an ancestral species . . . [–] is commonly regarded as requiring, on average, from several hundred to several thousand years to complete. To an experimental biologist, the process is hopelessly slow . . . [But, to] a paleontologist, . . . speciation seems almost blindingly quick, especially when contrasted with much longer periods (millions of years, often) . . . [during which] species appear to persist relatively unchanged. (pp. 37–8)

Yet one aspect of punctuated equilibrium must be evaluated as most central, while some apparent aspects turn out to be peripheral or even misleading. For example, in the estimation of Gould (1982):

Of the two claims of punctuated equilibrium – geologically rapid origins and subsequent stasis – the first has received the most attention, but . . . [it must be] repeated[ly] emphasized that . . . the second . . . [is] most important. We . . . [may], and not facetiously, take . . . as our motto: stasis is data . . . [I.e., s]tasis can be studied directly . . . [, and t]he (potential) validation of punctuated equilibrium will rely primarily upon the documentation of stasis. (p. 86)⁷²

Punctuated equilibrium is a specific claim about speciation and its deployment in geological time; it should not be used as a synonym for any theory of rapid evolutionary change at any scale. (p. 84)

Despite such caveats, however, certain historical linguists and other students of non-biological evolutionary change have been unable to resist the temptation to draw parallels between biological punctuationism and diachronic phenomena in their own fields, particularly on the basis of facts like the following socio-linguistic realities summarized by Labov (1994: 24):

[C]atastrophic events . . . play . . . a major role in the history of all languages, primarily in the form of population dislocations: migrations, invasions, conquests . . . Other abrupt political changes . . . le[a]d to alterations in the normative structure of the speech community. . . . [S]ignificant external effects are of this catastrophic type, while all gradual effects are internal, structural reactions set off by these rare disruptions. . . . The external history of most languages shows the uneven path of development that corresponds well to the sporadic character of sound change [sporadic, that is, in its unpredictability of occurrence, despite the regularity of its outcome]. . . . It remains to be seen whether the two types of uneven development can be fitted together, or whether language and social change are both erratic and independently motivated.

After all, this coincidence involving linguistic and politico-demographic catastrophes is extremely reminiscent of the paleontological finding expressed by Eldredge (1985: 168) as follows: “nearly every burst of evolutionary activity

represents a rebound following a devastating episode of extinction," whereby the "truly severe extinctions took out up to 90 percent of all species then on . . . earth." (Further discussion of extinction rates and even apparently cyclic mass-extinction patterns can be found, e.g., in Lawton and May 1995 and the extensive references there, as well as in more generally oriented works like Raup 1986.)

It is thus not really surprising that, in light of its suggestive name and its seeming applicability well beyond biology, the concept of punctuated equilibrium has exercised an influence stretching deep into other fields like psychology, anthropology, sociology, political science, economics, philosophy (cf. the range of papers in Somit and Peterson 1992 on *The Punctuated Equilibrium Debate in the Natural and Social Sciences*, to which "and in the Humanities" should have been appended), and, most recently, historical linguistics. However, radically (and radially) extending punctuationism outside biology has led to such far-reaching reinterpretations that these quasi-mutations among peripheral populations have ended up paralleling the very evolutionary mechanism that underlies punctuated equilibrium itself. This is, namely, *peripatric speciation*, one subtype of the larger category of *allopatric* (née *geographic*) speciation,⁷³ whose importance was first pointed out by Mayr (1942, 1954, 1963: 481–515 et passim) in work often seen as building on the sort of findings reported by Dobzhansky (1937) and particularly on Wright's (1931, 1932) earlier research concerning genetic drift (i.e., distributional asymmetries arising in small populations), most of it later summarized in Provine (1986). As we have already indicated, certain works on historical linguistics exemplify precisely this phenomenon whereby conceptual speciation of "punctuated equilibrium" has occurred on the periphery (or, more accurately, the exterior) of biology: thus, for instance, the publisher's blurb (on p. i) for Dixon (1997) describes that book as "offer[ing] . . . a new approach to language change, the punctuated equilibrium model." Similarly, Lass (1997: 304) takes it to be obvious that, "not dissimilar to the picture of 'punctuated equilibrium' . . . in biology, . . . languages . . . vary all the time, but they change in bursts."

Forming the background for these issues is Darwin's (1859: 341–2) contention, in *The Origin of Species*, that apparent gaps in the evolutionary development of species are simply accidental lacunae resulting from the non-preservation of intermediate forms in the fossil record:⁷⁴

The geological record is extremely imperfect . . . [.] this fact will to a large extent explain why we do not find interminable variants . . . connecting together all the extinct and existing forms of life by the finest graduated steps. He who rejects these views on the nature of the geological record . . . will rightly reject my whole theory.

Disagreeing with this claim, however, Eldredge and Gould (1972) took as their point of departure the view that evolutionary gaps are not apparent, but real, so that abrupt transitions in the fossil record at a given site or region must be

taken at face value. On this view, evolution – at the level of *species*⁷⁵ – does not occur via infinitesimal changes continuously accumulating at a constant rate, but via occasional, relatively short bursts of comparatively rapid speciation which can be seen as starkly setting off (or punctuating) the considerably long intervening periods of non-speciational stasis (i.e., periods of provisional equilibrium). Crucial here is the focus both on the geologically sudden appearance and on the subsequent persistence of entire species – particularly on the permanent replacement of one species by another from within the same phylum (i.e., either species selection or, alternatively, species sorting; cf. Stanley 1975, 1979; Gould 1985, 1990; Eldredge 1995: 119ff) – rather than on the gradual transformation of a complete species or complete phylum (“phyletic gradualism”) or on transitions between individual organisms. This fits well with the arguments provided by Ghiselin (1974, 1987, 1989) and Hull (1976, 1978, 1999), among others, in favor of treating species themselves as “individuals” (i.e., as collectivities functioning as higher-level units) which are smaller than phyla but larger than organisms (and populations). For more detailed discussion of species and species formation, see Mayr (1963: 14, or 1957), on the much earlier literature, and Endler (1977) or White (1978), plus Jameson (1977) or Barigozzi (1982), on the more recent literature. Rather closer to the present are the treatments of species and speciation given in Ereshefsky (1992) or Claridge et al. (1997), Wilson (1990), Giddings et al. (1989), Otte and Endler (1989), Kimbel and Martin (1993), Lambert and Hamish (1995), and, most recently, Howard and Berlocher (1998), Magurán and May (1999), or Wheeler and Meier (2000).

Bringing to the punctuation-versus-stasis distinction a primary focus on species-as-individuals, rather than on organisms-as-individuals, is what allows Eldredge, Gould, Stanley, Vrba, and others to avoid contradiction in maintaining both (i) that transitions between species are abrupt and (ii) that this fact need not be attributed to so-called “macro-mutations” in organisms (for background, see Dietrich 1992). Hence punctuationists can adopt a non-Darwinian (because literal) reading of the fossil record without abandoning Darwin’s adherence to Linnaeus’ dictum (cf. von Linné 1753: §77) that nature does not make (evolutionary) leaps: *Natura non facit saltus [sic]*.⁷⁶ The apparent dilemma here can be resolved by making use of Mayr’s above-mentioned notion of allopatric – especially peripatric – speciation. That is, a series of heritable mutations in individual organisms must indeed be responsible for speciation, but this occurs in some other (Greek *allo-*) place than in the ancestral core “homeland,” or “fatherland” (Greek *pátra*), of the species – usually taking place, instead, around (Greek *peri*) the edges of its range.

Beyond its suggestive parallelism with the linguistic finding that communicative isolation promotes increasing divergence between dialects, Mayr’s (1942, 1954, 1963/1979) achievement in linking together geographical isolation and speciation is noteworthy because it actually represents quite a departure from Darwin’s (1859: 51–2) practice in treating:

the term *species* . . . as one [that is] arbitrarily given for the sake of convenience to a set of individuals closely resembling each other . . . [and so] does not essentially differ from the term *variety*, . . . given to less distinct and more fluctuating forms . . . [, which], again, in comparison with mere individual differences, is also applied arbitrarily, and for mere convenience sake.

In short, Darwin's denial of species as systematic entities existing in nature made it impossible for him to address speciation insightfully – so that, as Mayr (1963: 13) puts it:

[As for that] . . . great evolutionary classic . . . *On the Origin of Species* . . . [, it] is not . . . widely recognized that Darwin failed to solve the problem indicated by the title of his work. Although he demonstrated the modification of species in the time dimension, he never seriously attempted a rigorous analysis of the problem of the multiplication of species, the splitting of one species into two.

In fact, as Sober (1993: 143) has trenchantly phrased such matters (cf. also Stanley 1981: 14):

Perhaps a less elegant but more apposite title for Darwin's book would have been *On the Unreality of Species as Shown by Natural Selection* . . . [– yet, if] species are [not] . . . real, how could a theory . . . explain their origin? . . . [Indeed,] Darwin thought . . . that there . . . [is] no uniquely correct way to sort organisms into species . . . [;] species are unreal . . . [– but not . . .] higher taxa, such as genera, families, orders, and kingdoms. . . Darwin [(1859: 420)] thought that th[e] . . . phylogenetic branching process provides *the* objective basis for taxonomy . . . : “all true classification is genealogical; . . . community of descent is the hidden bond which naturalists have been unconsciously seeking, . . . [not] the mere putting together and separating objects more or less alike.”

Although Sober (1993) and Mayr (1963, plus previously as well as subsequently: e.g., 1942, 1997) both judge Darwin (1859) as having erred in downplaying the evolutionary role of biological species, it is intriguing that Darwin's approach – essentially the view that “it's branches all the way down” – is basically identical to the perspective which diachronic (and synchronic) linguists have tended to adopt. That is, given the well-known difficulties (primarily of a sociolinguistic nature) connected with attempts to define any language as a collection of structurally similar or mutually intelligible dialects, many linguists have viewed *dialect* as the more tractable term, since the joint genetic pedigree of related dialects remains much easier to determine than speakers' possible recategorization of cognate dialects as different languages. It is this viewpoint which yields book titles referring to, for example, “the Italic dialects” (as in Conway et al.'s 1933 three volumes with that same name) or to “the Germanic dialects” (as in Baskett 1920, *Parts of the Body in the Later Germanic Dialects*). At the same time, most historical linguists have avoided the error made by Darwin when he overlooked the importance of isolation for

speciation – and dialect differentiation. On the other hand, paleontologists as a whole have been far ahead of historical linguists when it comes to recognizing the non-recoverability (hence the necessarily incomplete reconstructibility) of certain ancestral entities. And this biological insight, too, is intimately tied up with Mayr's emphasis on the role of peripheral isolates in (peripatric) speciation.

In evolutionary terms, that is, a selectionally shaped mutational development on a species' periphery – whose crucial outcome is reproductive isolation – usually occurs with such rapidity, and among so few organisms, that it essentially never survives into the fossil record. (Recall – from n. 17 – Engelmann and Wiley's (1977: 3) statement that they “do not know of any paleontologist who would claim to recognize an individual ancestor . . . in the fossil record.”) What fossils tend to show, rather, is an abrupt replacement such that the sort of organisms remaining in the “ancestral homeland(s)” – so also Dawkins (1986: 238–9) – suddenly yield to those of an originally peripheral variety, whereby this kind of situation arises when ecological changes or other external events promote the return of a once small and ancestor-like (but now large and crucially mutated) allo-/peri-patric population.⁷⁷ In this regard, considerable confusion has been caused by biologists and other scholars who have de-emphasized not only Eldredge, Gould et al.'s organism/species distinction, but also their description of punctuations as being quasi-instantaneous in geological time. Given the existence of obvious linguistic parallels to the scenario just sketched (e.g., when a construction that arose and spread slowly within the colloquial speech of a socially peripheral group later enters the formal register of written records with relative rapidity⁷⁸), it is quite unfortunate that disequilibrating punctuations have been misinterpreted as occurring virtually instantaneously in absolute time.

In a (geo)paleontological context, though, a “short” burst of “rapid” speciation is virtually never reducible to a duration any more “punctual” than 10,000 years, and only rarely and serendipitously limited to 10,000–20,000 years in length (cf. Gould 2000: 339–45).⁷⁹ This is because, as Stebbins (1982: 16) puts it, often even “60,000 years is so short relative to geological periods that it cannot be measured by geologists or paleontologists . . . [; hence t]he origin of a new kind of animal in 100,000 years or less is regarded by paleontologists as ‘sudden’ or ‘instantaneous’.” Thus, for example, the sharp-toned criticisms of punctuationism intended by Dawkins (1986: 230ff, 241–8, 1996: 105, 2000: 195–7) to tie Eldredge, Gould et al. to macro-mutations within individual organisms are simply irrelevant to those authors' actual focus on species-as-individuals. That is, the speciation which eventually occurs via geologically rapid replacement in an ancestral homeland, while far from being either continuous or infinitesimal, still has a gradual (stepwise) component. This is because it requires no saltational macro-mutations of the sort that could produce a human-like or even an insect-like eye in a single leap, as it were, but instead involves a very large number of intermediate generations which simply happen to pass by too quickly, too peripherally, and among too few individuals to appear in the fossil record.

The drastic compressions to which the vagaries of (non-)preservation can subject the objects that are produced (and/or reproduced) over lengthy time-spans are brought home to us, as linguists living and working shortly after the year 2000, by historian Felipe Fernández-Armesto's (1995: 11) suspicions about how little will ultimately remain of our own experiences and memorabilia from the last millennium, in that the author mentions his:

vision of some galactic museum of the distant future in which diet Coke cans will share with coats of chain mail a single small vitrine marked "Planet Earth, 1000–2000, Christian Era" . . . [M]aterial from every period and every part of the world . . . over the last thousand years . . . will be seen . . . as evidence of the same quaint, remote culture . . . [both] bankers' plastic and Benin bronzes. The distinctions apparent to us . . . [today], as we look back on the history of our thousand years . . . , will be obliterated by the perspective of long time and vast distance. Chronology will fuse like crystals in a crucible, and our assumptions about the relative importance of events will be clouded or clarified by a terrible length of hindsight.

Given that distortions of this sort (compression fractures, so to speak) are inevitable whenever the very closest comparanda across fossil records of any kind, linguistic or otherwise, are separated by millennia (in linguistic evolution) or even – to coin a useful term – millionennia (in biological evolution), how can we be so confident about our diachronic-linguistic activity in attempting to reconstruct details and overall structures of earlier language-states – as well as major changes in these – on the basis of arguably scanty textual evidence? Probably the best that we can do is to confess explicitly that any seemingly direct pairing of an apparent etymon with a reflex from which it is separated by hundreds or even thousands of years surely reflects, not an actual innovation, but a diachronic correspondence (recall section 1.2.1 above): that is, it is virtually certain that numerous intermediate steps were involved, even if it is now possible only to speculate about them. For example, the abrupt appearance in documents of a linguistic innovation at a considerably advanced stage of generalization (say, the distinctive palatalization of all consonants before any formerly – but not necessarily still – front vowel) does not force historical phonologists to posit a single macro-change leaping from no change to a maximum effect. After all, it can rarely be ruled out that such a general pattern may have evolved via stepwise extension from an originally much more limited set of inputs and contexts (more detailed discussion along these lines can be found in Janda and Joseph 2001 on sound change and in Janda 2001 on both phonological and morphosyntactic change) – that is, via a linguistic expansion process all of whose non-final stages may have been realized only in informal speech, without any reflection in the formal register of writing (cf. again n. 21).

In short, as an activity based heavily on studying fragmentary, fossil-like documents that are subject to similar vagaries of preservation and destruction, the study of language change, too, can be said to have its "geological" time as

well as its peripheral isolates – and this fact justifies micro-mutational alternatives to the previously mentioned objectionable macro-mutations which, in biology, critics like Dawkins have attempted to link unfavorably with punctuated equilibrium. Still, while Dawkins may have aimed at punctuationism (as a whole) and missed, his critical arrow can find at least one mark within the community of historical linguists. In particular, the straw man that Dawkins (1986: 223–4) intentionally sets up in seeking to show that Eldredge, Gould, et al. have not overturned orthodox Darwinian gradualism is strikingly reminiscent of certain writings on grammaticalization theory.⁸⁰ Dawkins’s straw man is an imaginary proponent of the view that, since “[t]he children of Israel, according to the [biblical] *Exodus* story, took 40 years to migrate across the Sinai desert to the Promised Land . . . [–] a distance of some 200 miles . . . [– t]heir average speed was therefore approximately 24 yards per day, or 1 yard per hour.”

Of course, this can hardly be an exact figure, since one must factor in the lack of travel at night (hence Dawkins revises his wilderness speed-figure to 3 yards per hour). Yet, as Dawkins (1986: 223) goes on to observe:

[h]owever we do the calculation, we are dealing with an absurdly slow average speed, much slower than the proverbially slow snail’s pace (an incredible 55 yards per hour is the speed of the world-record snail according to the *Guinness Book of Records*). But of course nobody really believes that the average speed was continuously and uniformly maintained. Obviously the Israelites traveled in fits and starts, perhaps camping for long periods in one spot before moving on.

Now, Dawkins’s point in setting up this dummy view is to demonstrate the lack of novelty of the punctuationalist (“fits and starts”) approach. Next, he continues (still on p. 223):

suppose that eloquent young historians burst upon the scene. Biblical history so far, they tell us, has been dominated by the “gradualistic” school of thought . . . [, which] literally believe[s] that the Israelites . . . folded their tents every morning, crawled 24 yards in an east-northeasterly direction, and then pitched camp again. The only alternative to “gradualism”, we are told, is the dynamic new “punctuationalist” school of history . . . [, a]ccording to the radical[s] of which] . . . the Israelites spent most of their time in “stasis”, not moving at all but camped, often for years at a time, in one place. Then they would move on, rather fast, to a new encampment, where they again stayed for several years. Their progress towards the Promised Land, instead of being gradual and continuous . . . [involved] long periods of stasis punctuated by brief periods of rapid movement. Moreover, the . . . bursts of movement were not always in the direction of the Promised Land.

While we obviously think that a gradual and continuous version of the *Exodus* migration would be exactly as far-fetched as Dawkins makes it sound, essentially this sort of scenario appears to be accepted by most grammaticalizationists for such phenomena as potentially millennia-long changes from (i) stressed full word to (ii) prosodically weak clitic to (iii) unstressed suffix to

(iv) zero. For instance, Greenberg (1991) traced the development of the Aramaic definite suffix *-a* “over a period of approximately 3000 years” (p. 302). Greenberg himself masterfully divided the overall change involved into a sequence of individual and discrete changes, but the fact remains that many – if not most – grammaticalizationists assert the reality and even the conceptually necessary status of grammaticalization as a virtually indivisible continuum. Still, given the vast timespans over which grammaticalization is often said to occur, as well as the existence of counter-grammaticalizational phenomena – for examples and discussion, see especially Janda (2001: 269 et passim), along with the other papers in Campbell (2001b) – we view it as virtually certain that much of what is now called “grammaticalization” actually displays punctuational tendencies (“fits and starts”). We see no more reason to think that all “morphemes grammaticalize” irreversibly, continuously, gradually, and at a constant rate, across thousands of individuals and hundreds of years – as in Haspelmath’s (1998: 344) “gradual unidirectional change . . . turn[ing] . . . lexical items into grammatical items” – than we do to assume that the Israelites of Exodus moved northeasterly toward the Promised Land at a fixed rate of 24 yards per day while traveling through the wilderness. Indeed, it is believing in either of these tall tales that is likely to entrap the gullible in a wilderness of gratuitous assumptions.

In short, then, Dawkins (1986) surely was wrong to assume that no serious scholar in any historical discipline focusing on how fossil-like records reflect speciation-like phenomena over millennia could ever find glacial gradualism (much less seamless continuity) to be worthy of serious consideration as a possible major tempo and mode of change. Rather, the advocates of a yards-per-day account of the Exodus migration, intended by Dawkins as straw-filled caricatures, actually have flesh-and-blood counterparts among grammaticalizationists within diachronic linguistics. Indeed, given the failure of many historical linguists to address the above-mentioned distinction between diachronic correspondences and actual innovations (again recall section 1.2.1 above), it can fairly be said that what Dawkins takes to be the obvious and non-newsworthy core of punctuationism – that is, predominantly gradual real-time transitions between (mostly unpreserved) individual organisms versus periodically abrupt geological-time leaps between preserved fossils bearing on the species level – remains (and most likely will long continue to be) a bone of contention among students of language change.

Admittedly, issues of gradualism/continuity versus punctuationism are ripe for misunderstanding outside of linguistics, as well – both in biology and in other fields. We have already remarked, for example, on Dawkins’s tendency to underreport Eldredge, Gould et al.’s focus on entire species, rather than individual organisms, in discussions of punctuated equilibrium. Still, the greatest distortions of the latter concept have occurred on the periphery of biology: that is, in non-physical disciplines which have nonetheless tried to adopt biological metaphors – including, as adumbrated above, linguistics, especially in its diachronic aspect.

1.2.3.5 *Parallels between biological and linguistic evolution: some fruitful, some not*

The irony here, as noted at the start of the previous section, is that the metamorphosing/mutation of punctuated equilibrium in peripheral fields – into variant notions far removed from its original sense in biology – iconically mirrors the very notion of peripatric speciation which provides the foundation for punctuationism. For example, Lightfoot (1999a: 18, 84, 228, 231–2), in devoting considerable discussion to linguistic instantiations, or at least purported analogues, of punctuated equilibrium, omits mention of the species-level focus of Eldredge, Gould, et al., even though his characterization of individual speakers' grammatical reanalyses as “catastrophic changes” (in the technical sense) runs directly counter to the supra-individual, quasi-social emphasis in published explications by biological punctuationists themselves.⁸¹ Indeed, both punctuationists and their critics agree on the crucial role played by migration in accounting for the non-gradual transitions in the fossil record, and, as already discussed above in n. 17, migration is clearly a contact- and group-related social factor – hence arguably a form of spread; cf., for example, Dawkins (1986: 240–1; original emphasis):

[I]f . . . the “transition” from ancestral . . . to descendant species appears to be abrupt . . . [, the reason may be] simply that, when we look at a series of fossils from any one place, we are probably not looking at an *evolutionary* . . . [but] a *migrational* event, the arrival of a new species from another geographical area . . . [. T]he fossil record . . . is *particularly* imperfect just when it gets interesting, . . . when evolutionary change is taking place . . . [. T]his is partly because evolution usually occurred in a different place from where we find most of our fossils . . . [,] and partly because, even if we were fortunate enough to dig in one of the small outlying areas where most evolutionary change went on, that evolutionary change (though still gradual) occupie[d] . . . such a short time that we . . . [would] need an extra rich fossil record in order to track it.

Paleontology, then – diachronic biology, so to speak – provides essentially no *direct* evidence (as opposed to inferential considerations – so-called “how else?” arguments –) regarding the crucial role of innovating/innovative *individual* organisms in evolutionary change. But is there some way in which synchronic biological studies of rapidly reproducing organisms can perhaps compensate for this lacuna? Again, in principle, yes; in practice, however, no.

It is not difficult to compile a solid list with documented cases of rapid contemporary evolution. We have in mind here more than just instances like Goodfriend and Gould's (1996) demonstration that evolution of shell-ribbing in the Bahamian snail *Cerion rubicundum* occurred via a geologically punctuational “ten-to-twenty-thousand-year transition by hybridization,” or Lenski and Travisano's (1994) meticulous recording of increases in average cell-size over 2000 generations of replications (slightly different in each case, despite maximally identical experimental conditions) by each of 12 different populations

of the human-gut bacterium *E(scherichia) coli*. Much more convincing to the general public, rather, is the better-known example (cf. Weiner 1995; Grant and Grant 1999, and references there) involving persistent changes – as a response to rapid climatic alterations – in the size and strength of the bills of Darwin’s finches on the Galápagos Islands. No less deserving of close attention, though, is the research of Reznick et al. (1977), who traced changes in Trinidadian guppies’ maturity rates (and in other reproduction-related behaviors known to be highly heritable) over eleven years, for females, and as little as four years, for males. Losos et al. (1997), on the other hand, were able to document an adaptation of Bahamian lizards’ average leg-length (ecologically conditioned according to whether the dominant local flora consisted mainly of trees and other vegetation with thick perching places or of bushes having narrow twigs) over only 20 years. (For further discussion of such studies, see Gould 2000: esp. 334–41ff)

Yet, as Gould (2000: 335) summarizes concisely:

[B]iologists have documented a veritable glut of . . . rapid and . . . measurable [modern] evolution on timescales of years and decades . . . [in spite of t]he urban legend . . . that evolution is too slow to document in palpable human lifetimes. . . . [Yet, although t]he . . . truth has affirmed innumerable cases of measurable evolution at this minimal scale – [still,] to be visible at all over so short a span, [such] evolution must be far too rapid (and transient) to serve as the basis for major transformations in geological time . . . – or, “if you can see it all, it’s too fast to matter in the long run!”.

That is, even if the fast-track evolution among individual creatures which can be currently observed is assumed also to have been characteristic among the prehistoric organisms now preserved only in fossils (even if what we see is what prehistory got, so to speak), the associated rates of change are not slow enough to explain the glacial pace of broad trends in the fossil record. Indeed, says Gould (2000: 344):

[t]hese measured changes over years and decades are too fast . . . to build the history of life by simple cumulation . . . [E.g., Reznick et al.’s (1977)] guppy rates range from 3,700 to 45,000 darwins (a . . . metric for evolution, expressed as a change in units of standard deviation – . . . [in particular, as a] measure of variation around the mean value of a trait in a population – per million years). By contrast, rates for major trends in the fossil record generally range from 0.1 to 1.0 darwin[s – so that] . . . the estimated rates . . . for guppies . . . are . . . four to seven orders of magnitude greater than . . . [for] fossil[s] (that is, ten thousand to ten million times faster).

Far from being disappointing, however, this finding actually provides a number of reasons for students of language change – and not just biologists – to be especially content. For one thing, the above-mentioned examples of rapidly trending but not lasting directions of variation present linguists with

a crucial caveat to remember in their diachronic studies. Namely, some variation is stable (occasionally for surprisingly long periods of time – a point that we stress below in section 1.2.3.8, in connection with the age-grading example of a youngster's *Mommy* yielding to an adolescent's *Mom*, and see NICHOLS'S chapter 5 regarding other kinds of stability in language over time), so that variants which one encounters for the first time – and thus takes to be innovative harbingers of future developments – may well be neither recent in origin nor likely to win out in the future. We emphasize this point because of our own experience as speakers of English. After living for an appreciable period of time (into our twenties) without any feeling that much linguistic change was occurring (recall Bynon's 1977: 1, 6 previously quoted suggestion that most speakers are unaware of real changes in language precisely because they are so preoccupied with the social significance of alternative forms that they overlook their correlation with time), we later (especially in our thirties, and increasingly in our forties) became convinced that many diverse trends had just started and were surely proceeding rapidly toward their endpoint, maybe even to be completed during our lifetimes. Yet caution directs us to concede that perhaps very little of the variation which is currently known will survive for very long (even if it outlives us), much less undergo strengthening and expansion across most or all varieties of our native language. Gould (2000: 345) draws a remarkably similar conclusion regarding the rapid but ephemeral biological-evolutionary phenomena here summarized further above, incidentally (but intentionally) implying that their reversibility is largely responsible for the equilibrium (= stasis) part of the punctuational two-step (on this point, cf. also Eldredge 1995: 69–78):

Most cases like the Trinidadian guppies and Bahamian lizards represent . . . momentary blips and fillips that “flesh out” the rich history of lineages in stasis, not the atoms of substantial and steadily accumulated evolutionary trends. Stasis is a dynamic phenomenon. Small local populations and parts of lineages make short and temporary forays of transient adaptation, but these tiny units almost always die out or get reintroduced into the general pool of the species. . . . [N]ew island populations of lizards . . . , tiny and temporary colonies . . . [,] are almost always extirpated by hurricanes in the long run.

Linguists (of the synchronic as well as the diachronic persuasion) will hear here – for example, in Gould's statement that “Stasis is a dynamic phenomenon” – an echo of Jakobson's (1981: 374) credo that he had, ever “[s]ince . . . [his] earliest report of 1927 to the new . . . Prague Linguistic Circle . . . [Pražský lingvistický kroužek,] propounded the idea of permanently dynamic synchrony.”

Now, Eldredge (1989: 206–7, 1995: 64–5, 78–85, 1999/2000: 142–3) had in fact already argued that the geographically limited, single-population locus of most evolutionary phenomena plays a major role in promoting stasis – in regard to both “habitat tracking” and the isolation of populations within a species (on these two points, see also Futuyma 1992: 104–7 et passim):

[B]y far the most common response of species to environmental change is that they move – they change their locus of existence . . . [,] seek[ing] familiar living conditions . . . [,] habitats that are “recognizable” to them based on the adaptations already in place . . . [; t]his is “habitat tracking . . . [”, a] constant search . . . , generation after generation, within every species on the face of the earth . . . [.] Species tend to change locale . . . [,] rather than anatom[y, as soon as a] . . . suitable habitat can be found . . . [; i.e., they do not] stay put and adapt to new environmental regimes. (Eldredge 1995: 64–5, 78)

Wright . . . [(1931, 1932, 1982)] gave us the fundamental view of species organization still with us today: species are composed of a series of semi-isolated populations. . . . Species are . . . necessarily disjunct in their distributions, despite the . . . [usually rather] neat line that can be drawn around their entire range of distribution . . . [.] Hence] the semi-isolated populations within a given species undergo . . . semi-independent evolutionary histories. . . . Given this . . . organization, it defies credulity that any single species, as a whole, will undergo massive, across-the-board gradual change in any one particular direction. (Eldredge 1995: 82–3)

[E]ach local population . . . liv[es] . . . in [an] ecosystem . . . with somewhat different physical environments, predators, and prey . . . , with its own sampling of the genetic variation of the entire species, . . . [with a] different mutational histor[y] . . . [and] history of genetic drift . . . and . . . [of] natural selection . . . [.] It is highly unlikely that natural selection could ever “move” all the populations of an entire species in any one single evolutionary direction for any significant amount of time at all. (Eldredge 1999/2000: 143)

For paleontological data strongly supportive of this view, see now especially Lieberman et al. (1995). But of course all of this only goes to strengthen further the conclusion that the primary mechanism of speciation really is peripatric in nature, thus necessarily involving one or more peripheral, isolated populations.

Using this notion heuristically, we can then further ask whether population-based (i.e., population-constrained) stasis in evolutionary biology has any close analogues in the domain of language change – a question which appears to have a decidedly affirmative answer. As we have already hinted (in n. 75), the most appropriate linguistic equivalent of a biological population (or “deme”) would seem to be either a speech-community (cf. here GUY’S chapter 8), or – more probably – a social network of interacting speakers; research on the linguistic role of networks has been pioneered by Lesley and James Milroy (cf., e.g., L. Milroy 1980, 1987; L. Milroy and J. Milroy 1992; J. Milroy and L. Milroy 1985; J. Milroy 1992; J. Milroy and L. Milroy 1992) and is here discussed in some detail by WOLFRAM AND SCHILLING-ESTES’S chapter 24. Crucially, network studies reveal that, despite the frequent observation (already found in Bloomfield 1933) that language changes tend to start in the most populous and most culturally important urban areas and then to filter down from there to successively less populous cities, towns, and, lastly, rural villages – each time skipping over smaller intervening populations – the prerequisite for such spread

of linguistic innovations is a network structure which includes people with loose ties to many social groups but strong ties to none; that is, a typically urban characteristic. But, in populations with dense, multiplex social networks involving frequent and prolonged contact among the members of small peer groups across many social contexts, these close ties promote greater resistance to the adoption of linguistic innovations: in short, dense, multiplex social networks promote relatively greater (but by no means absolute) linguistic stasis. It is worth stressing that networks of this sort seem to have been overwhelmingly predominant among humans for essentially all of their prehistory (given that the origin of writing seems roughly to have accompanied the rise of urbanization; cf., e.g., Renfrew and Bahn 2000).

Here – in juxtaposing not human languages and biological species, but instead small, close-knit social networks (to which the Milroys have rightly drawn linguists' attention) and local populations of organisms (the demes on which Sewall Wright helped biologists to focus) – we might initially be tempted to think that we have indeed found a factor which can and does promote punctuated equilibrium in human language(s). At the very least, treating social networks as a crucial element in language change provides a useful corrective for anyone tempted to speak monolithically about changes “in English” (as a whole), or even just “in American English” or “New York City English,” since all of these agglomerations not only consist ultimately of individuals but also are highly reticulated. Moreover, it appears accurate to conclude that, when one simply compares all of the dialects (and subdialectal network varieties) of a language, probably the majority of linguistic features which are shared by all varieties represent traits jointly inherited from their common linguistic ancestor, rather than innovations which arose in one variety (or a sprinkling of varieties) but were then eventually diffused from there to *all* other varieties of the language at issue. Individual linguistic networks (and even larger speech-communities and dialects) really can be surprisingly resistant to certain changes.⁸² For example, many authors discuss the so-called Great Vowel Shift which marks the transition from later Middle English (ME) to earlier Modern/New English (NE) not only as if it were phonologically uniform (in spite of, e.g., Stockwell and Minkova 1987) but also as if it had affected every dialect of the language. Yet it is well documented in *The Survey of English Dialects* (cf., e.g., Orton 1962; Orton and Halliday 1962, 1963a, 1963b; Kolb 1966; and later atlases) that, in “Northumberland, Cumberland, and Durham . . . [m]ost of the dialects . . . still have a high back rounded vowel” as the reflex of ME long [u:] in words like *cow*, *out*, and *mouse* (cf. the summary and related discussion in Janda 1987: 354).

Nor should we forget that, ever since the initial rise of city states in ancient Mesopotamia several millennia ago, urban centers have exercised a continuing magnetic attraction on rural populations that leads to a kind of mobility among humans which strikes us as quantitatively (though perhaps not qualitatively) quite different from the situations of other biological species. For instance, one occasionally hears bandied about, in informal discussions of linguistic change,

such statements as the allegation that, “Until 1900, most people in the world never traveled more than 50 miles from their birthplace during their lifetimes” (significantly, we know of no published instantiation of this claim). However, meticulous scholarship by historians like Bailyn (1987: 20–1) has documented findings like the following:

If . . . one uncontroversial fact . . . has emerged from the . . . decades of research [1955–85] in European social history, it is that the traditional society of early modern Europe was a mobile society – a world in motion. . . . Rich [(1950) had earlier] stressed the relationship between domestic migration and overseas migration . . . [; in addition, h]e found a persistence rate in selected Elizabethan villages over a ten-year period of no more than fifty percent . . . [,] estimat[ing] . . . that only sixteen percent of all Elizabethan families had remained in the same village as long as a century . . . []. Since then], the picture has been greatly elaborated . . . by local historians . . . [and by] historical geographers. . . . We now know . . . that the English population[’s] . . . mobil[ity] . . . was a composite of three closely interwoven patterns [= with movements locally over short distances, regionally over longer distance, and London-ward over variable distances].

Moreover, quite apart from the fact that Milroy(i)an (at their finest, Milroyal) network studies have stressed the importance, alongside denser groups, of looser-knit social groupings – which tend to counteract static equilibrium in language – even biologists have been quick to point out that (most of) language and other aspects of human culture are transmitted across time (and space) via non-genetic mechanisms which endow linguistic and other cultural “evolution” with a decidedly non-biological character. On this point, there is complete accord even between “ultra-Darwinians” (cf., e.g., Eldredge 1995: 4), on the one hand, and punctuationists like Eldredge and Gould, on the other hand. Dawkins’s (1986) take on the relevant differences-within-similarities is as follows:

Darwin[’s] . . . successors have been tempted to see evolution in everything, . . . [even] in fashions in skirt lengths. Sometimes such analogies can be immensely fruitful, but it is easy to push . . . [them] too far. . . . The trick is to strike a balance between too much indiscriminate analogizing . . . and a sterile blindness to fruitful analogies. (p. 195)

[I]n human cultural evolution . . . , choice by whom matters . . . [, although c]ultural evolution is not really evolution at all . . . [,] if we are being fussy and purist about our use of words . . . []. Still, i]t has frequently been pointed out . . . that there is something quasi-evolutionary about many aspects of human history. If you sample a particular aspect of human life at regular intervals, . . . of one century or perhaps one decade, you will find . . . true trends . . . , without [all of] these . . . being, in any obvious sense, improvements. Languages clearly evolve in that they show trends . . . [,] they diverge, and . . . [,] as the centuries go by after their divergence . . . [,] they become more and more mutually unintelligible. (pp. 216–17)

Gould (1991: 63–5), for his part, has been even more explicit about the true nature of the parallels under consideration – and, unlike Dawkins, he does not fail to mention the important additional role played by such convergence-promoting phenomena of direct cultural contact as borrowing:

[C]omparisons between biological evolution and human cultural or technological change have done vastly more harm than good – and examples abound of this most common of all intellectual traps. Biological evolution is a bad analogue for cultural change because the two are . . . different . . . for three major reasons that could hardly be more fundamental. . . First, cultural evolution can be faster by orders of magnitude than biological change at its maximal Darwinian rate – and . . . timing . . . [is] of the essence in evolutionary arguments. Second, cultural evolution is direct and Lamarckian in form: . . . [t]he achievements of one generation are passed . . . directly to descendants, thus producing the great potential speed of cultural change. Biological evolution is indirect and Darwinian . . . [:] favorable traits do not descend to the next generation unless, by good fortune, they arise as products of genetic change. Third, the basic topologies of biological and cultural change are completely different. Biological evolution is a system of constant divergence without subsequent joining of branches. In human history, transmission across lineages is, perhaps, the major source of cultural change. Europeans learned about corn and potatoes from Native Americans and gave them smallpox in return.

These considerations, though, do not ineluctably obligate us to believe that episodes of language change should be primarily brief and abrupt, rather than continuous and gradual, and they certainly do not appear to favor stasis over innovation(s). On these grounds alone, we are surely justified in concluding that (based on the present sifting of diverse available evidence) a maximally close analogue of punctuated evolution in biology has not so far been established as the *general* case within the set of phenomena often referred to as linguistic evolution. Yet this conclusion is actually not very different from the situation in biology, where it turns out that the most illuminating question to ask is no longer “Does punctuated equilibrium exist?” (since yes, it does), or “Does the evolution of *all* species seem to be punctuational in nature?” (since no, although this is true for many species), but instead “Which aspects of the evolution of which species appear to be punctuational in nature?”⁸³

Thus, linguists can most assuredly profit – and profit the most – from investigating which particular aspects of which specific languages subject to which external circumstances seem to have undergone the most rapid changes or to have shown the longest periods of stasis – this last notion more often being referred to by linguists as “stability.” That a solid start and some progress along these lines has already been made is demonstrated by a growing body of research that includes such pioneering studies as Fodor (1965) and Mithun (1984). Mithun, for instance, compared “functionally comparable but formally different devices” across six Northern Iroquoian languages and, on that basis, suggested (pp. 330–1) that morphosyntax is more stable than the lexicon, with

syntax being functionally more stable than morphology and (within the lexicon) predicates being more stable than particles. The “hierarchy of stability across these . . . interlocking domains” therefore seems to be, “in order of increasing volatility,” as follows: syntax, morphology, predicates, particles. (Janda 2001: 310–11n.14 observes that these differential rates of stability versus change render even more implausible the claim of some grammaticalizationists – recall the discussion in the previous section – that a single linguistic element undergoing successive reanalyses across several linguistic domains must always display a constant grammaticalization rate.) More recently, Nichols (1992a and many subsequent works) has devoted particularly close attention to the differential stability of different linguistic elements; NICHOLS’s chapter 5 here thus discusses in considerable detail what is presently known about this topic, likewise providing extensive references.

As a general methodological point, it is worth emphasizing at this juncture how much more revealing it is – both in historical linguistics and in evolutionary biology – to adopt the divide-and-conquer strategy of posing many local questions regarding some possibly large-scale trend, rather than making one global query. We have just mentioned the benefits that linguists like Mithun and Nichols have derived from asking numerous small questions (here concerning differential rates of stability across components and units of grammar; cf. also Joseph and Janda 1988: 205–6 (n. 12) and Janda et al. 1994 on the statistical predominance of “local generalizations” over more global ones), but there exists a striking biological analogue to this. Although the particular suggestion by Stebbins (1982) that we have in mind was made in an introductory textbook intended for laypeople, and although it was superseded by more technical later treatments of the relevant phenomena, the fact remains that the analytical tack adopted by Stebbins toward the start of the debate over punctuationism was indeed prescient, being far more productive than the winner-take-all tug-of-war which tended to dominate the time of his writing.

In particular, Stebbins (1982) decided to address punctuated equilibrium in connection with a response to the *Alice-in-Wonderland*-inspired “Red Queen” hypothesis of Van Valen (1973) and others, so named because it has to do with active evolutionary “running” just in order to “stay in the same place” (cf. also Stanley and Yang 1982 on so-called “zigzag evolution” – e.g., in clams). Observing that some living animals and plants look very much like their ancient fossil ancestors, despite “constant changes . . . [in] internal, largely biochemical characteristics” that cannot be detected from fossils, Stebbins (pp. 20–1) argued that, at least for these, the Red Queen hypothesis may be valid. He highlighted, for example, the “evolutionary constancy” of small, secretive, or sedentary animals like shrews, oysters, jellyfishes, cockroaches, scorpions, and many kinds of worms, which already have met successfully “all the environmental challenges . . . of scores or hundreds of million years.”⁸⁴ These, he contrasted with such living things as song birds and mice (“small, highly active creatures”) or large carnivores (lions, birds of prey, etc.), for all of whom environmental challenges (e.g., “new and different predators”

for the former, “elusiveness of their prey” for the latter) have continually motivated adaptations whose effects are highly visible in the fossil record. This kind of correlation had not gone unnoticed before, but Stebbins rightly connected it with the punctuationism debate.

In addition, however, Stebbins (1982: 138–9) cited previous research by Wilson et al. (1974) and King and Wilson (1975) – cf. also, (later) Wilson et al. (1987) – suggesting that the same kind of differentiated evolutionary rates may be more directly detectable at the level of individual genes, especially those which code for cellular proteins; this might lead one to conclude that genes coding for cellular proteins “often and perhaps always” evolve at different rates from those that determine overall body plan, including anatomical structure:

[C]himpanzees . . . [and] humans . . . [show very] strong resemblances between cellular proteins . . . in spite of large . . . differences in external anatomy. Among frogs, pairs of species . . . almost identical in overall body plan and anatomy nevertheless are far more different from each other with respect to cellular proteins than are apes from humans . . . [T]here [may be] something about their overall genetic constitution that makes mammals more susceptible to changes in anatomy . . . [, whereas] frogs [are] more susceptible to changes in cellular proteins.

However, Stebbins (1982: 139) argued that such reasoning need not point directly to the sort of punctuationism in which a successful response to a challenge can be made relatively quickly – “in a few thousand generations, by anatomical changes” – after which evolution “may proceed very slowly until the population faces another environmental challenge.” Still, on the other hand, many environmental challenges may exert what amounts to “only low to moderate selective pressures on cellular proteins,” a fact that is well known from comparisons between humans and chimpanzees. Therefore, suggests Stebbins (1982: 139), evolutionary changes in these molecules could continue slowly for long periods of time, and so it is possible that:

evolution of anatomical structure and function often proceeds . . . punctua[lly] . . . , while evolution of most cellular enzymes proceeds more gradually . . . , with the combined] result . . . be[ing] a hare and tortoise pattern. . . . [I]n a young group, newly evolved lines would differ more from each other with respect to anatomy and outward form than with respect to enzymes . . . [; i]n an old group, the reverse would be the case. . . . This explanation agrees with observations. Mammals are relatively young . . . [, having] diversified rapidly between 50 . . . and 60 million years ago . . . [, whereas] frogs . . . acquired their present body plan more than 200 millions years ago.

Here again, we would stress that the main import for historical linguists of such earlier ruminations by a biologist like Stebbins (1982) is that they show the advantages to be gained by studying rate of change not globally but

componentially, with attention paid simultaneously to various entities on multiple levels involving different relative dimensions of focus (recall, too, the above-mentioned start made in this direction by linguistic diachronicians like Fodor, Mithun, and Nichols). Stebbins's lead was, in turn, borne out by the later and much more broadly based conclusions of Hunter et al. (1988), whose broad survey of recent research suggested that stasis occurs more often in such macroscopic fossils as marine arthropods, bivalves, corals, and bryozoans, while gradualist patterns tend to predominate in foraminifera, radiolarians, and other microscopic marine forms (for a brief survey of these and most other forms of life, see Tudge 2000, plus references there).

We thus conclude that, given the uncertainties which currently reign among evolutionists as to precisely what (non-zero) number and which varieties of taxa (taxonomic groupings of various sizes) are associated with stasis-cum-punctuationism versus gradualism, students of language change should not feel undue concern over the fact that the relative roles and frequency of sudden versus gradual change have not yet been satisfactorily determined in linguistics, either. While this may gladden those linguists who assume that historical research on language and on biology necessarily should (nearly) always yield parallel results, such is not at all our reading of the situation. Our belief, rather, is that uncertainties in another field which is often attended to by one's own specialty can be useful in suggesting that external disciplines are actually most helpful if scouted out heuristically – as available sources for borrowing (or generating) novel hypotheses and other ideas – rather than taken as models for emulation. The danger in the latter case, of course, is that too close a shadowing of another field can tempt scholars to interpret ambiguous cases (and even to nudge their unambiguous results) in the direction which the relevant other discipline would lead one to expect, and the consequences of this strategy can be particularly grave if the model field in question is subject to dramatic or rapid changes in its dominant orientation(s). In the case of language and biology, then, there can be no harm in diachronicians' treating punctuational change, stasis, and gradual change as if those notions had been proposed wholly within linguistics and just accidentally happen to have extradisciplinary counterparts.

Even while saying this, we do not wish to downplay too much the productive interpenetrations and suggestive resemblances that already characterize the relationship between historical linguists and evolutionists. For example, Platnick and Cameron (1977) is an interdisciplinary study of cladistic methods in three domains – linguistics, textual studies, and phylogenetic analysis by evolutionists – and is in fact a collaboratively biologist+linguist-authored article that appeared in the journal *Systematic Zoology*. Harvey and Pagel's (1991) treatment of *The Comparative Method in Evolutionary Biology* is also of considerable potential interest to diachronicians of language (although it tends to bug linguists who read all of its pages, since the book makes essentially no reference to the substantial existence of a comparative method in historical linguistics). And the set of several papers collected in Nerlich (1989), despite its focus mainly on

evolution in the sense of language change, does make some connections with evolutionary biology. On the other hand, there are even some publications of a wholly (or at least primarily) biological nature which still provide sobering suggestions for those linguists who are perhaps somewhat too mesmerized by genetics and, in particular, by recent genomic research.

Marks (2000), for example, presents a reaction to such frequently bandied-about facts as the finding that “geneticists have been able to determine with precision that humans and chimpanzees are 98 percent identical genetically” – which could even lead some diachronicians (as well as synchronicians) of language to suggest that studies of chimpanzee communication (whether in the wild or in captivity) might throw a directly useful light on human linguistic abilities. Instead, Marks suggests, we would do better to confess (and confront) our unfamiliarity with genetic comparisons. It is this ignorance which leads us to overlook the fact that, since DNA is a linear array of four bases, there exist only four possibilities as to what base will occur at any specific point in a DNA sequence, and therefore “[t]he laws of chance tell us that two random sequences from species that have no ancestry in common will match at about one in every four sites.” Thus, even two unrelated DNA sequences will be 25 percent identical, and this fact has implications not only for comparisons between two kinds of animals, but also for comparisons between animals and plants, since “all multicellular life is related . . . and . . . shares a remote common ancestry.” Taking this information and running with it, Marks concludes that:

if we compare any particular DNA sequence in a human and a banana, the sequence would have to be more than 25 percent identical. For the sake of argument, let’s say 35 percent. In other words, your DNA is over one-third the same as a banana’s. Yet, of course, there are few ways other than genetically in which a human could be shown to be one-third identical to a banana.

In light of these background considerations, we doubt whether (m)any linguists, historically minded or not, would find much appeal in the prospect of devoting, say, 25 percent of their time to studying the communicative abilities of bananas. Sometimes, it appears, we simply have to let biology be itself. And, actually, an exhortation along these lines has already been issued to us by the often-quoted last sentence of Voltaire’s (1759: 86) *Candide*: “Mais il faut cultiver notre jardin” – which (cf. Wootton 2000: xliii, 135) is in fact best translated as “But we have to work our land(s)” or “cultivate our field(s).”⁸⁵ That is, protagonist *Candide*’s last(-mentioned) piece of advice is significantly *not* “Il faut cultiver le jardin d’autrui” and especially not “Il faut que quelqu’un d’autre cultive notre jardin,” which would respectively mean “We have to cultivate somebody else’s field(s)” and “Somebody else has to cultivate our field(s)/land(s).” Of course, historical linguists’ labor need not be pure, in the sense that they can profitably crib hints from watching how biologists work in their own field and then apply such inspiration to the field of linguistic change. But,

still (with apologies to Bernstein et al. 1955), it would be wise as well as good – and certainly for the best, we know – if diachronicians of language would both thoroughly observe biological practice and also do all the necessary linguistic spadework before they attempt to implant any fruits of evolutionists' thinking within linguistic accounts which deal with specific language changes. Not every garden-variety outgrowth of recent developments in the field of biology can find an insightful application in the work of historical linguists. Before concluding this section, therefore, we take a brief look at a (somewhat indirectly) punctuated-equilibrium-related concept which (i) has been borrowed from biology by certain linguists and used in one kind of research on language change but (ii) has not yet been shown to provide a more satisfactory account than certain other biological or even linguistic concepts would have done.

The evolutionary notion known as the *founder principle* (or *effect*) was adopted by Mufwene (1996) from biology – he cites only Harrison et al. 1988 (*Human Biology: An Introduction to Human Evolution, Variation, Growth, and Adaptation*) – and applied by him to those arenas of linguistic change connected with the study of creole languages. Mufwene's goal thereby was to “analogize ‘language’ to ‘population’ in population genetics,”⁸⁶ thereby “hoping to account more adequately for some aspects of language restructuring . . . in contact situations, especially those associated with the varieties called ‘creoles’” (pp. 83–4). The relevance of the founder principle and of founder populations to the above goal was that these concepts allegedly help to explain “how structural features of creoles have been predetermined to a large extent (but not exclusively!) by characteristics of the vernaculars spoken by the populations that founded the colonies in which they developed.” That is, since European colonies often began with large numbers of indentured servants and other low-status employees of colonial companies, the presence of so many speakers of non-standard varieties of the creoles' European lexifier-languages can be invoked in order to explain “the 17th and 18th-century non-standard origin of several features of creoles.” The specific relevance of the founder principle emerges more directly when Mufwene states his assumption that “some features which might be considered disadvantageous . . . in the metropolitan varieties of the European lexifier-languages” – “because they are rare, not dominant, and/or used by a minority” – “may well have become advantageous in the speech of the colonies' founder populations.” One such example proposed by Mufwene (1966) involves the presence of locative-progressive constructions like *be up(on) V-ing* in earlier varieties of English (reflexes of which are still found today, in some non-standard varieties, as *be a-V-in'*).

Mufwene (1996: 84–5) focuses as follows on certain additional ways in which, he claims, the biological founder principle bears on the genesis of creoles (for that author's more recent views, see Mufwene 2001 (*The Ecology of Language Evolution*), which manifestly also uses a certain amount of biologically oriented terminology):

[T]ypical population-genetics . . . explanations for the dominance of . . . disadvantageous features in a (colony's) population are: 1) such features may have been reintroduced by mutation; 2) they may have been favored by new ecological conditions in the colony . . . [,] or 3) the colony may have received significant proportions of carriers of the features/genes, a situation which maximized the chances for their successful reproduction . . . [.] In creole genesis[. . .] the 2nd and 3rd reasons account largely for the restructuring of the lexifier [in/as the creole]. True mutations are rare, though there are plenty of adaptations . . . [.] The developments of creoles a[re] . . . instances of natural adaptations of languages qua populations to changing ecological conditions. In every colony, selection of the lexifier for large-scale communication in an ethnographic ecology that differed from the metropolitan setting called for the adaptations that resulted in a new language variety.

At this point, we should hasten to state that there clearly are at least superficial similarities between the biological founder principle (for which we quote biologists' definitions further below) and certain linguistic situations. NICHOLS'S chapter 5 (in its section 4.2), for example, discusses in some detail a geographical distribution whereby two "low-viability features" (numeral classifiers and verb-subject word order) having no obvious grammatical interconnections are associated with each other in a large group of Pacific Rim languages spoken in the far western Americas – from which Nichols concludes that this association "must reflect the . . . two features' accidental cooccurrence in their ancestral language or population," and that the latter was once a "small colonizing population."

One crucial aspect of founder effects – which, not surprisingly, are invariably due to the founder principle – is thus that a small, isolated founding population is always involved. This is reflected, for example, by the summary of Mayr's (1954) original treatment of the principle in his later (1982) survey of *The Evolution of Biological Thought*. In particular, because he was "aware of the frequency of founder populations beyond the periphery of the solid species range," Mayr (1954) "finally" saw that founder populations "would be the ideal place for a drastic genetic reorganization of the gene pool in the absence of any noticeable gene flow and under conditions of a more or less strikingly different physical and biotic environment" (Mayr 1982: 602). In this regard, it is indeed generally agreed by biologists that the founder principle per se (as opposed to the interacting factor of gene flow) was initially proposed and most strongly advocated by Mayr, and this is indicated by frequent references in the literature to "Mayr's founder principle," as in Ereshefsky (1992: 89, 95). (Hence Mufwene's (1996) failure to mention Mayr at all must simply be an oversight.) However, it is less than clear that those linguistic phenomena which are described as founder effects always involve direct analogs of their alleged biological counterparts.

Perhaps most striking is the disparity between, on the one hand, Labov's (1972a, 1994–2001) defense of unmonitored, casual-style, working-class speech

as essentially least marked and, on the other hand, Mufwene's above-mentioned (1996) assertion that the features spread in creoles due to the founder principle might be considered disadvantageous in the metropolitan varieties of the European lexifier-languages "because they are rare, not dominant, and/or used by a minority." Here, on the contrary, it would appear that, aside from the problem of quite probably lacking (overt) prestige, the linguistic features in question would most likely be both frequent and dominant – due to their occurrence in unmonitored, casual-style, natural speech – and it further appears that, as features of working-class speech, such features would not in fact be used by a minority, either, but by a majority or at least a plurality. All of this begins to make Mufwene's (1996) proposed analogy between the genetically governed biological founder principle and its putative linguistic counterpart look much more tenuous; indeed, the relevant linguistic phenomena now increasingly start to sound much more like cultural-behavioral issues. Yet this seems to be consonant with Labov's very recent (2001: 503–4) characterization of the linguistic founder effect in terms of a kind of gatekeeper function:

The doctrine of first effective settlement . . . [– cf.] Zelinsky 1992 . . . [–] limits the influence of new groups entering an established community . . . [by] asserting that the original group determines the cultural pattern for those to follow, even if these newcomers are many times the number of the original settlers. This is consistent with the fact that New York City, Philadelphia, Boston, and Chicago, cities largely composed of 19th-century immigrants from Europe, show only slight influences from the languages of these ethnic groups in the form of the local dialect . . . [Only if, i]n any one generation, . . . the numbers of immigrants rise to a higher order of magnitude than the extant population . . . [can] the doctrine . . . be overthrown, with qualitative changes in the general speech pattern. (pp. 503–4)

Moreover, Labov also observes that this principle did not originate in the 1990s, but was in fact "independently formulated . . . in Creole studies . . . by Sankoff (1980) as the 'first past the post' principle."

Yet there is one final observation of a biological nature to be made here, and this is that, since the linguistic data presently being considered come from a creole language, we should at least briefly reconsider Thomason and Kaufman's (1988) view that abrupt creolization involves "shift without normal transmission" (for her more recent, solo views, cf. THOMASON'S chapter 23 here). And this should in turn lead us at least to consider the possibility that an equally good or perhaps even better biological analog (than the founder principle) might be involved: namely, hybridization (cf., e.g., a classic paper like Anderson and Stebbins's 1954 discussion of "Hybridization as an evolutionary stimulus" and compare Trudgill 1996 on "dual-source pidgins"). On the other hand, though, hybridization is not inherently linked with punctuated-equilibrium phenomena in the way that the biological founder principle is; Mayr (1997: 183), for example, directly states that, "[i]n peripatric speciation, a founder population is established beyond the periphery of the previous species' range,"

and we know that peripatric speciation seems to be firmly linked with punctuationism. As a result, a decision to abandon biological-founder-principle explanations in favor of biological-hybridization-principle explanations would force us to end our discussions of punctuated equilibrium sooner rather than – as here and now – later.

While this excursion into paleobiology admittedly has not done full justice to the huge specialized literature on punctuationism in the several relevant subfields of biology, it does suffice to show the dangers of glibly importing technical terminology whose specific senses in specialist (i.e., non-linguistic) parlance display, not surprisingly, exactly the number and kind of arbitrary semantic accretions that linguists should expect. If interpreted extremely broadly, as throughout Dixon's (1997) monograph, or in the brief statement by Labov (1994: 24) quoted above ("catastrophic events . . . play . . . a major role in the history of all languages"; recall also Lass 1997: 304), a punctuated-equilibrium approach to language change seems to have much going for it. That is, it does appear that major structural changes in the phonology or morphosyntax of a language are not a yearly or even a centennial occurrence. Observation over time thus tends to reveal a kind of stasis in what could be called the skeleton and organs of a language which most often are relatively unaffected by the constant but minor semantic and other lexical innovations in the covering flesh and skin. But there are linguistic analyses which invoke punctuationism for the sole purpose of justifying accounts expressed in terms of "catastrophes," where a given change occurs (in toto) via one individual speaker's grammatical reanalysis across adjacent generations – even though this approach ignores the crucial limitation of biologists' punctuations to changes taking place in geological time – that is (to repeat), ones occurring over thousands and tens of thousands of years. (Recall that, as Gould 2000: 340 puts it, "even ten thousand years represents a geological eye-blink in the fullness of evolutionary time.") This kind of error, since it arises from misinterpreting one chronological scale of measurement as if it were another temporal yardstick, is thus reminiscent of the 1999 immolation, in the Martian atmosphere, of the multimillion dollar *Climate Orbiter* space probe, which burned up (after months of successful space travel) due to an interpretive mix-up involving the unnoticed combination of Anglo-American and metric units of measurement in the calculation of its trajectory.

Lexical borrowing is certainly familiar to historical linguists (and cf., again, THOMASON'S chapter 23 herein), but, rather than just borrowing terms with conceptually suggestive names and then essentially guessing what the meaning of a certain item is "in biology," diachronicians have much to gain from actually reading a variety of biologists' competing views on the relevant topics (cf. the numerous references listed above, plus the synoptic surveys provided by such collections as Sober 1994; Ridley 1997; Hull and Ruse 1998). Those who do, we are convinced, will find that, while the notion of punctuated equilibrium has linguistic analogs, it most assuredly does not motivate the exclusionary focus on individual speakers advocated by so many diachronic

and synchronic linguists. While all biologists indeed uniformly recognize that there is a crucial individual side in phylogenetic evolution (especially speciation), as well as in ontogenetic development, they are, on the whole, much more rarely subject to temporary amnesia concerning the importance of interactions within and between ecologically defined groups than linguists seem to be. The proper balance between group focus and individual focus has been well expressed in Mayr's many discussions of "population thinking" (cf., e.g., 1997: 310 et passim, plus references there), which takes biological populations and larger natural groupings (like species) seriously – but at the same time "emphasizes the uniqueness of every individual in populations . . . [.] and therefore the[ir] real variability."

While individuals are not all there is, the fact remains that even groups of people are indeed made up of discontinuous entities, and so we have reason to return, in the next two sections, to the issue of discontinuity between individuals as it relates to matters of change (here, in language) – a topic which was a particular favorite of the distinguished evolutionary biologist Dobzhansky (cf., e.g., 1937: 4–5 ("Discontinuity") et passim, 1970: 19–24 ("The Discontinuity of Individuals" and "The Discontinuity of Arrays of Individuals").

1.2.3.6 *Discontinuity of language transmission even in what "doesn't change"*

Most scholars who study linguistic change would surely agree with Kiparsky (1968: 175) that "a language is not some gradually and imperceptibly changing object which smoothly floats through time and space, as historical linguistics based on philological material all too easily suggests" (e.g., recall the still deceptively well-preserved book from 1775 discussed here in n. 28). Rather, "the transmission of language is discontinuous," as Kiparsky himself had already stressed earlier (cf. 1965: I.4, II.12–13); see, too, the later, similar phrasing of Lightfoot (1979: 148, 1981: 212). In generative grammar, this view was apparently first expressed by Halle (1962: 64–5). But Halle also mentioned several illustrious predecessors – including figures like von Humboldt (1836), Paul (1880), Herzog (1904: 57ff), and Meillet (1904–5, 1929) – who had held similar views long before him. Halle, in turn, reported that Meillet's work had first been brought to his attention by Edward S. Klima, who soon pursued a similar approach in Klima (1964, 1965), while Kiparsky acknowledged the influence of unpublished prior statements by G. Hubert Matthews and Paul Postal (the latter's views later appearing in print as Postal 1968: 269–81, 308–9).

As for Meillet, there is great irony in the fact that, despite the frequency of observations (e.g., here in HEINE's chapter 18 and many references there) that twentieth-century grammaticalization studies began with Meillet (1912), there is virtually no mention in the diachronic-linguistic literature of the great French scholar's very clear views (quoted by Halle 1962: 64n.9–66n.11) regarding the cross-generational discontinuity of language transmission. A substantial (and earlier) statement concerning this topic can be found in Meillet (1904–5: 6–7):

One must keep in mind from the very start the essentially discontinuous character of the transmission of language. . . . This discontinuity . . . would not in itself suffice to explain anything, but, without it, all the causes of change would without a doubt be powerless to transform the meaning of words as radically as has happened in a large number of cases . . . [I]n a general way, moreover, the discontinuity of transmission is the prime condition which determines the possibility and the modalities of all linguistic changes.

Elsewhere (1929: 74–5), Meillet describes language as being transmitted through being “recreated by each child on the basis of the speech data it hears.” These are Meillet’s own words (in translation), but they have been put to various different uses by later writers. For a critical analysis of the generative (re)interpretation imposed by Halle (1962) on his French forerunner, see Baron (1977: 28–34, 47n.11–48n.15).

At least as memorable as Meillet’s prose statements on transmissional discontinuity in language, though, are the schematic diagrams later provided first by Klima (1965: 83), then – slightly revising the original – by King (1969: 85), next – again with revisions – by Andersen (1973: 767, 778; cf. also 1990: 13), and lastly – in its most complex form – by Traugott (1973a: 41–5, 1973b: 316–17). See Janda (2001: 274–5) for a discussion that lists not only later, similar diagrams but also many prose discussions implying them.

Unfortunately, many scholars’ acceptance of these particular discontinuity-emphasizing diagrams as a general type seems to have been seriously compromised because they embody – or even just because they have been associated with – certain questionable but much less central generativist claims regarding diachrony. Among these secondary aspects, whose objectionableness has been especially harmful in overshadowing the core notion that language is transmitted discontinuously, are the following implications: (i) that children are the primary instigators of linguistic change (via simplification), (ii) that children acquire language mainly from an older generation (whose additions complicate grammar), and (iii) that speakers have only a single, variation-free grammar. Based on numerous actual past misunderstandings of discontinuity claims and graphics, we wish to forestall possible future misinterpretations by explicitly emphasizing – and in the strongest possible terms – that we ourselves categorically reject all three of the above assertions. Hence figure I.5 is likewise intended to imply rejection of these claims, and so we present it as a significantly revised and updated version of diagrams dating from the mid-to-late 1960s and early 1970s (originally derived from Halle, Matthews, Postal, and Kiparsky) that were evolved by Klima, King, Andersen, and Traugott; the diagram reproduced here thus presents the considerably revised version developed by Janda (2001: 277).

In figure I.5, the major focus is on the idiolect of one particular speaker/hearer, here labeled individual C – with an analogous situation understood as holding for any given signer-viewer – but the various pairs of ellipses signal the existence of additional relevant generations besides N–1, N, and N+1, and of individuals beyond A, B, and C within them. Other individuals than C

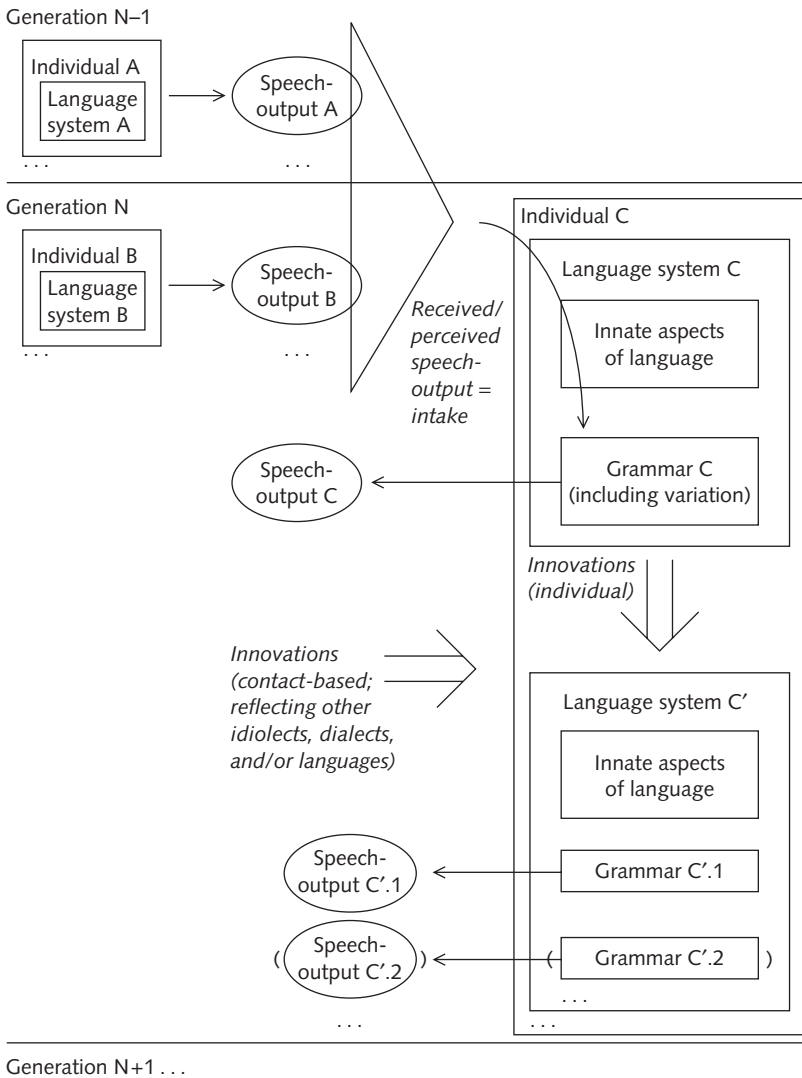

Figure I.5 The discontinuous transmission of language and its relation to change: a revised schema

Source: Janda (2001: 277), after Klima (1965); King (1969); Andersen (1973); Traugott (1973a, 1973b)

clearly also have both (i) innate aspects of language – a.k.a. a(n) LAD (Language Acquisition Device) or UG (Universal Grammar) – and (ii) an acquired grammar, but these have here been collapsed as language systems A and B, etc. The large arrowhead-like triangle intersecting speech-outputs A and B shows not only that the speech of more than one individual (and generation)

is relevant for both language acquisition and language change, but also that no one ever hears the entire speech-output of anyone else, and that what is physically heard is subject to interpretation. That is, there is a difference between input and intake, as stressed for second-language acquisition by researchers like first Corder (1967: 165) and then Chaudron (1985), Zobl (1985), and several other authors in Gass and Madden (1985).

Within individual C, there are two temporally sequenced language states, an earlier (or even earliest) state C and a later (or even latest) state C'; the former is altered into the latter as the result of innovations which sometimes are internally individual (perhaps partly maturational) but more often are contact-based (and so can involve both intended accommodation and unintended hypercorrection). Language system C' also allows for the parenthesized option of a second grammar C'.2 (and, as suggested by the ellipsis, allows for additional other grammars) besides C'.1, this in connection with diglossic situations (cf. originally Ferguson 1959) where sets of linguistic features vary in tandem and so justify simultaneous multiple grammars (cf., more recently, Kroch 1989a; Lightfoot 1991: 136–40). In addition, though, all of the grammars in the above schema should be interpreted as including variation, some of which may best be treated in terms of variable rules (cf., e.g., Labov 1972, 1994) and/or in terms of competing alternative constructions or multiple analyses (cf., e.g., Fillmore et al. 1988; Harris and Campbell 1995: 51, 59, 70–2, 81–9, 113, 310–12).

As its eclectic and general nature suggests, the graphic figure I.5 is intended to be specific only about those aspects of language transmission and linguistic change regarding which relative certainty or at least consensus can be assumed; the details have been either omitted or only vaguely hinted at for matters concerning which there exists significant disagreement or substantial doubt. Thus, for example, the absence of precise age-related information regarding the language systems of C and C' in individual C at various stages allows for some influence of a (rather than **the*) child on language change, but without forcing us to view childhood as the primary chronological locus of linguistic innovations (for discussion, cf. Aitchison 1981, quoted from 2001: 201–10, 216; especially Romaine 1989). In light of the still-controversial nature of generations, both as idealized constructs and as agents in models of language acquisition, it seems best to follow the suggestions of Manly (1930) and – more recently – Weinreich et al. (1968):

[T]here ha[s] . . . been a curious failure on the part of scholars to recognize, or perhaps rather to emphasize, what actually occurs in the transmission of a language from generation to generation. The actual facts are, of course, known to everyone. . . . There is no such thing in reality as a succession of generations. Yet scholars constantly write as if there were. The community is renewed and continued, not by successive generations, but by a constant stream of births. This fact is of importance in all questions concerning the transmission of human culture. It is of supreme importance in the history of human speech. . . . [E]ach and every child, during the formative period of . . . speech, is more closely and intimately associated with children slightly older than . . . [him/herself] than with adults . . .

and is psychologically more receptive of influence from these children than from adults. (Manly 1930: 288–9)

[T]here is a mounting body of evidence that the language of each child is continually being restructured during his[or her] preadolescent years on the model of his [or her] peer group. Current studies of preadolescent peer groups show that the child normally acquires his [or her] particular dialect pattern, including recent changes, from children only slightly older than himself [or herself]. (Weinreich et al. 1968: 145)

All of these authors, it should be noted, make prominent reference to the fact that the transmission of language is both temporally and spatially trans-individual, and hence also discontinuous in an important sense. On the other hand, it bears repeating (recall sections 1.2.3.1–1.2.3.3 above) that, although the discontinuous transmission of language plays a role in the introduction and propagation of linguistic innovations, even aspects of a language which are acquired by a speaker in a form unchanged from that used by an older generation are passed on and picked up via (or despite) transmissional discontinuity. It is thus the case that, as we have already observed previously, the more challenging fact about linguistic change is not how much of language changes in a short time, but instead how relatively little of it undergoes rapid alteration (cf., e.g., Nichols 1992a; NICHOLS'S chapter 5 here) – a situation whose suggestive parallels with biological evolution were discussed in the preceding section (which cited such works as, e.g., Eldredge 1991: 44–47). For further references and discussion, see also Janda (2001: 310–11n.14).

Since figure I.5 above directly connects the discontinuity of language transmission with individual speakers, a further word on individuals vis-à-vis speech communities is in order here. We have already cited Labov (1994: 45n.2) as viewing a “language as a property of the speech community” and “preferring to avoid a focus on the individual, since the language has not in effect changed unless the change is accepted as part of the language by other speakers.” Still, it remains the case that, since grammars are properties of individual brains, whereas a community has no (single) brain, there can be no such thing as a “community grammar” except as a linguist’s construct. Instead, rephrasing Labov’s observation, we can conclude that a given linguistic innovation is potentially more revealing to the extent that it comes to characterize many individuals’ grammars. In this regard, it is significant that Labov (1997) has made a start toward a synthesis of views by focusing on those specific – influential – individuals who are most likely to spread linguistic innovations to groups of other individuals, and hence eventually to an entire speech-community. In addition, Labov (1999) has recently discussed the individual “outliers” (quantitatively anomalous speakers) who are so frequently encountered in variationist studies. For more discussion, see again the work of James Milroy (e.g., 1993: 223), to whom is due the extremely useful distinction – whose wider adoption we have already advocated above in section 1.2.1 – between an *innovation* (which may be made by an individual speaker) and a

change (which is a community's increasing adoption of some innovation); this trend has been continued and elaborated by Milroy (1999), among others.

1.2.3.7 *Discontinuity of individual grammars and the last rites of linguistic organicism*

Although all linguists must, at some level, be aware that it is speakers who act in and on language – and not linguistic units that act in and on speakers – one can nevertheless find statements like the following, which comes from Pagliuca's (1994: ix) introduction to a collection of papers all on the topic of grammaticalization (on which herein cf. especially JOAN BYBEE'S chapter 19, HEINE'S chapter 18, MITHUN'S chapter 17, and ELIZABETH CLOSS TRAUGOTT'S chapter 20, but also, to a more limited extent, FORTSON'S chapter 21, HARRISON'S chapter 2, HANS HENRICH HOCK'S chapter 11, and BRIAN D. JOSEPH'S chapter 13):

As a lexical construction enters and continues along a grammaticalization pathway, . . . it undergoes successive changes . . . broadly interpretable as . . . a unidirectional movement away from its original specific and concrete reference and to increasingly abstract reference. Moreover, . . . material progressing along a pathway tends to undergo increasing phonological reduction and to become increasingly morphologically dependent on host material. . . . [T]he most advanced grammatical forms, in their travel along developmental pathways, may . . . undergo . . . continuous reduction from originally free, unbound items . . . to affixes.

Yet, given the transmissional discontinuity of languages – and hence of their morphosyntactic and lexical elements and principles – across individual minds, it behooves us to resist the temptation to view particular linguistic constructions (phrases, words, or morphemes) as if they were organisms with lifespans longer than those of humans by several orders of magnitude (much less as entities independent of people). This is not just misleading linguistics; it is also mutant biology.

One factor apparently responsible for the frequency with which grammaticalization studies (like the one quoted above) posit millennia-long “diachronic processes” and “mechanisms of change” is the temptation that exists to use biological – that is, organismal – metaphors for languages and linguistic entities. This misleading practice has already been criticized above, but the temptation is so strong (to judge from the number of linguists who apparently give in to it) that a few more words on this topic seem apposite here. The central point at issue is simply that the lives (i.e., the lifespans and lifetime activities) of biological organisms are not a good model for the “behavior” of – for what happens to and with – elements of language.

Actually, the more nearly accurate biological parallel is one where each speaker in the stream of overlapping generations is engaged in replicating morphemes which show strong phonological and semantic resemblances to morphemes used by a previous generation but often have distinct properties of form, category, or grammatical function (modulo the reservations expressed

above regarding idealized generations). It is this ceaselessly repeated replication (on which cf. also Lass 1997: 111–13, 354–81) that allows both for general trends (like the downgrading correspondence that usually holds between instantiations of “the same” morpheme in the grammars of earlier versus later generations) and for occasional reversals where an innovation in one generation vis-à-vis another sometimes proceeds contrary to the statistically predominant direction of reanalysis. The best illustration for the illusion which unfortunately bedevils so many studies of grammaticalization is one similar to the “cloning” analogy (in the non-technical sense) that was just adduced: namely, a child’s “flip book” – a low-tech instantiation of the principle that underlies motion pictures (for an example that is readily accessible, see Eames and Eames 1977, *Powers of Ten: A Flipbook* – based on a film of the same name). When a thumb is rapidly drawn down one unbound edge of such a booklet, a single figure appears to move across a single page, but there is in fact a rather long sequence of pages, each with a figure on it, though in a slightly different configuration relative to the figures on the other pages. Since we here have not one thing that changes, but only a temporal sequence of quite similar things, it is clear why, adopting essentially the same perspective as the current work on this specific issue, Coseriu (1982) chose to give his article a provocative title directly expressing its author’s view that “Linguistic change does not exist.”

Once we recognize that any linguistic phenomenon which appears to persist in relatively similar form over a period lasting hundreds of years necessarily requires multitudes of speakers to perform thousands of (near-)replications for some pattern of language, it becomes clear why innovations like those associated with grammaticalization arise in the first place, and with such frequency, as well as why there cannot be any “diachronic” unidirectionality constraints like those frequently discussed in the grammaticalization literature. That is, given the impossibility of any mechanisms which would restrict contemporary speakers’ linguistic behavior in the use of morphemes by forcing them to consult what long-past generations once did, the only valid limits that make sense are synchronic ones relating to: (i) what speakers’ minds predispose them to do in reaction to the data that they happen to hear around them, and (ii) their social attitudes of conformity, non-conformity, or hyperconformity to the usage of groups which produce such data. The former point, after all, is basically what Lightfoot (1979, this volume) has always emphasized, though a certain trigger-happy way of phrasing matters may have provoked some misunderstanding. In any case, such considerations should lead us to conclude that such commonly discussed and grammaticalizationally relevant notions as pragmatic subjectivization, semantic bleaching, morphosyntactic reanalysis, and phonetic reduction all actually constitute distinct synchronic phenomena which also exist apart from grammaticalization and so need not yield unitary, unidirectional/irreversible chains of linguistic development.

But, for anyone who adopts or maintains the metaphor whereby individual morphemes (and constructions) undergo putative long-term developments as if they were single living organisms, claims of unidirectionality/irreversibility

are quite consistent, since organisms live only forward. Nevertheless, the length and nature of the “path(way)s” which are thereby assumed provide some grounds for skepticism. In particular, the “path(way)” metaphor compares the sequences typically associated with grammaticalization phenomena to a walkway whose course is determined in advance because all of its parts are present and fixed at the outset. Indeed, with self-reflexive iconicity, much work on grammaticalization – itself often said (cf. Heine et al. 1991) to depend crucially on metaphor – relies heavily on a particular “path(way)” metaphor in which the walkway at issue leads gently but firmly downhill (as if gravity as well as narrowly spaced locking turnstiles prevented any retrograde movement) and is plastered with signs forbidding any wandering off the path to pick flowers or picnic on the grass. Yet it is not clear why and how speakers’ use of morphemes at any given moment in the history of a language should be prevented from involving, for example, hypercorrection in such a way as to halt or to reverse a downgrading trend – and, indeed, upgrading phenomena are surprisingly common, once one starts to look for examples.

In short, then, we can actually be grateful to those grammaticalizationists (like Pagliuca 1994) who indulge in biological metaphors that turn, for example, morphemes into organisms. This is because – once we consider such analogies – the lack of evidence for that particular kind of comparison helps lead us quickly to the more insightful comparison of morphemes with patterns of speech which are replicated in interchanges: sometimes between speakers of the same generation, but also between speakers of different generations. And, as regards replication and other aspects of the biological transmission of information, Dawkins (1998/2000: 192–3) suggests some extremely useful distinctions based on the practice of biologists (for an alternative view see Salthe 1993):

Modern biologists use the word *evolution* to mean a . . . process of systematic shifts in gene frequencies in populations, together with the resulting changes in what animals and plants actually look like as the generations go by . . . [.] Development is not the same thing as evolution. Development is change in the form of a single object, as clay deforms under a potter’s hands. Evolution, as seen in fossils taken from successive strata, is more like a sequence of frames in a cinema film. One frame doesn’t literally change into the next, but we experience an illusion of change if we project the frames in succession. With this distinction in place, we can quickly see that the cosmos does not evolve (it develops) but technology does evolve (early airplanes are not moulded into later ones . . . [.] but the history of aeroplanes . . . and of many other pieces of technology, falls well into the cinema frame analogy). Clothes fashions, too, evolve rather than develop. It is controversial whether the analogy between genetic evolution, on the one hand, and cultural or technical evolution, on the other, leads to illumination or the reverse.

These distinctions (and comparisons) will be useful to keep in mind as we now proceed to other topics (and leave behind, for dead, the notion that linguistic units of any kind are organisms).

1.2.3.8 *Change is not stable variation or identical but independent recurrence*

In a very real sense, there is an equally important additional question lurking in discussions like the above that absolutely demands to be answered, or at least asked, when we confront the phenomenon of change in language (and elsewhere). It is all well and good to ask what we mean by talking about “change” in the first place, but we must also more specifically ask what it is that comes to be different when a language changes. If – as indeed seems to be the case, in light of the argumentation just presented – the transmission of language is discontinuous, and if language is therefore replicated (*mutatis mutandis*) generation by generation, then differences between states become evident only via comparisons. But such comparative pairings of different linguistic states come in several varieties, some of which can give the impression of involving change without actually doing so. This circumstance forces diachronicians to exercise particular caution in dealing with those linguistic elements for which speakers employ two or more variants. That is, in cases where an examination of the present confronts observers with ongoing linguistic variation in some aspect of usage, this situation need not actually represent “change in progress,” even though that is a ready interpretation, one which is often accurate but just as often turns out not to be so.⁸⁷ Rather, the coexistence of two or more variants may represent stable variation that can persist over long periods of time and confront the analyst with an opposition whose members possess their own socially interpretable significance.

For example, the current variation between two types of words which English-speakers use in order to address their own parents – little children tend to be the ones who use terms such as *Mommy* or *Mummy* and *Daddy*, while adults tend to employ *Mom* and *Dad* or *Mother* and *Father* – is not a reflection of a currently ongoing change in English. Rather, the use by a speaker (especially a male) of, say, *Mommy/Mummy*, as opposed to *Mom* or *Mother*, says something about his or her age, degree of dependence, and the like, but it does not allow us to conclude that he or she belongs to a particular generation or “vintage” (in the sense of a group defined by the proximity of their birth years and hence also by many shared experiences). For example, any linguist who is told that a randomly chosen English-speaker at some point in time called or calls his mother *Mommy* can easily specify within 15 years that speaker’s age at the time (because saying “15 years old” will virtually guarantee success). But estimating such a speaker’s birth year is likely to result in blind guessing, since the speaker could have been born in 1995, or 1970, or 1945, or 1920, or 1895, or . . . That is, all of the available evidence known to us suggests that, for over a century at least, the vast majority of natively English-speaking children have called their parents *Mommy/Mummy* (or the like) up to a certain age, and then switched to *Mom/Mother* (or the like) for essentially the rest of their lives. In short, knowing that young(er) or old(er) speakers currently exhibit differences in some speech-pattern is not a sufficient basis for identifying the direction

or even verifying the existence of linguistic change. Instead, it is only when a situation involving such variability is compared with some other fixed temporal reference point, across real time, that it becomes possible to interpret the initial situation as reflecting change in progress and exhibiting a detectable directionality of change.

A practical consequence of this view is that, in order to make a meaningful assessment of some possible change, one has to establish beyond a reasonable doubt that, quite apart from the language-transmissional issues discussed in the preceding section (1.2.3.7), there really is some continuity between the “before” and the “after” that are being compared. In order to be maximally useful or even meaningful, a comparison of Old English with Modern English would have to control for dialect (as noted above in section 1.2.1.6), in order to ensure there is what we might term “direct lineal descent” between some element in stage 1 and its altered form in stage 2. At the same time, we also need to allow for independent (re)creation of phenomena at different stages.

Thus – to take a very specific, concrete example – the documented occurrence of *mo* for *homo(sexual)* in student slang at Duke University (in North Carolina) during the late 1980s⁸⁸ and its earlier attestation in the slang of adolescent boys at Camp Ethan Allen in Vermont during the early 1960s⁸⁹ most likely represents a pairing of forms that arose independently of each other. Each occurrence seems to have arisen as an only accidentally parallel selection from among the shared set of word-formation possibilities – a clipping, in this case – that characterize slang.⁹⁰ In this sense, there is a diachronic correspondence between 1960s Vermont *mo* and 1980s Duke *mo*, but nothing that clearly connects them via direct lineal descent, because there is nothing that fills in the temporal and geographical distance between them. Even with such independent occurrences, though, there are still diachronic questions to be asked: for example, how did each community come to create the relevant form?; how did it spread within each community?; and so on. Still, with no continuity, with no filling in of the gaps, there is here no connected history to speak of, but only distinct, separate occurrences, each rooted in its own present moment.

In talking about change in language, we necessarily take a diachronic perspective and investigate the effects of the temporal dimension on linguistic behavior by humans. We tend to focus on what has changed between language states, but, in a sense, it is equally revealing to note what does not change and to develop from that a sense of what can remain stable in a language through time. Clearly, anything about language that is truly universal should remain invariant across time,⁹¹ but our knowledge of truly absolute and inviolable universals of human language – “design features,” as it were – is rather circumscribed, at best. Recognizing, though, that some aspects of language do not change allows us to see change as something noteworthy when we do become aware of it, and thus as something that needs to be explained. Indeed, in chapter 2, HARRISON takes precisely such a view with regard to the workings of the comparative method, and, in chapter 5, NICHOLS similarly points to

various pockets of stability in language over time. Moreover, we know that arbitrary aspects of language can persist through time, and this again shows that there can be stable elements and temporal continuity. Labov (1989a: 85), for example, notes the situation whereby “children acquire at an early stage historically transmitted constraints on variables that appear to have no communicative significance, such as the grammatical conditioning of . . . [-ing versus -in’] in English,” and, among other, similar cases, he discusses the variable deletion of final [t]/[d] in English, as well (see also section 1.2.3.3 above).

To an extent, then, doing historical linguistics, or even just viewing language diachronically, involves an attempt to focus on precisely those aspects of language which require a kind of explanation that is often loosely called “historical,” as discussed earlier (see n. 68), but can more accurately be labeled *polysynchronic*. Thus, certain individual present-day phenomena can seem synchronically unmotivated vis-à-vis the overall patterns of a contemporary grammar, but they may turn out to make eminent sense when seen either (i) as survivals – passed on through a connected series of intermediate synchronic states – from a historically antecedent state in which they were synchronically motivated, or (ii) as analogies based ultimately on such survivals. In the above-mentioned case of *mo*, for instance, its post-clipping occurrence in two distinct locales at different times need not be explained with reference to history (the past) – via the positing of a direct lineal link between an earlier and a later synchronic state, since each clipped result can be motivated in its own right, at its own synchronic time and place. But, given the usual arbitrariness of the connection, in linguistic signs, between the signifier and the signified (à la Saussure), the fact that *m-* occurs at all in *mo* cannot be explained in (mono)synchronic terms (except through the accidental convergence of independent spontaneous coinages), much less on universal grounds (in contrast to what might be argued for, say, the *m-* of *ma* “mother”). Rather, the *m-* of *mo* can be explained only in terms of continuing retention from an earlier time, hence polysynchronically (but not really “historically”: after all, there are countless other phenomena whose origin in “history” – the past – has not guaranteed their survival into today’s present).⁹²

1.2.3.9 *Language change as change in language, not of language(s)*

In clarifying here what we mean by *change*, it is important to exclude certain conceivable senses of that word when it follows *language*. For instance, the label *language change* is not used in this volume to refer to what might be termed “language shift” or “language replacement” situations, especially ones involving a transfer of language loyalties and preferences from one tongue to another. This caveat is in no way intended to be facetious: Posner (1997: 3), for example, distinguishes between *linguistic change* (which affects “dynamic systems . . . [having] their own mechanisms of change”) and *language change* (since “the language of a community, as an entity, can change”); in so doing, she creates the strong impression that the latter term refers (primarily) to language shift.⁹³ In any case, to discuss a concrete possibility: if more and

more speakers in (the) Ukraine should now begin to use Russian, rather than Ukrainian, in their day-to-day affairs, one could talk about a change in language(s) taking place there, but this switch would involve the partial substitution of one language for another – a replacement of one language by another in a particular social arena – not an immediate change in either one of the two languages involved.⁹⁴ As important a topic as this general kind of shift may be, it is not, in itself, directly central to historical linguistics as the field has been defined here.

Rather similarly, the term *change* by itself is often used elsewhere in a purely synchronic sense. Consider example, the much-discussed Modern High German generalization of “final devoicing” (or, in German, *Auslaut(s)verhärtung*) as it relates to the word-final /g/ which can be motivated at the end of the underlying representation of, for example, the morpheme that means “dwarf” (on the basis of the phonetic [g] that surfaces in nominative plural *Zwerge* “dwarfs” (or “dwarves”). In this specific case, the relevant process is often said to “change” /g/ into phonetic [k] (or, on more structuralist accounts, into phonemic /k/) at the end of the (bare) nominative-singular form *Zwerg*. Now, admittedly, such alterations in form are frequently linked in important ways with historical phonology, since they are often the synchronic reflections of sound changes. See, for example, chapter 3 by RINGE on internal reconstruction, and chapter 9 by RICHARD D. JANDA, which refers in part to neutralization-related (a.k.a. morphophonemic) alternations like German [g] ~ [k] (but also is partly focused on the ways in which the so-called “phonologization” of former allophones really involves morphologization and lexicalization). Still, our interest here in synchronic alternations is restricted to the ways in which they arise from, and may reflect, past situations and events.

1.2.3.10 “Historic linguistics, you’re history!”: generalizing historical linguistics

Having devoted close attention to several of the issues connected with the concept and term *change*, we turn lastly to *history*, *historic*, and *historical*, yet another terminological nexus that figures prominently both in this work and in work on diachronic linguistics in general. We do so mainly because, within the field of historical linguistics, the label *historical* is sometimes employed in a way that gives rise to ambiguity (and thus also to at least some confusion), the latter due mainly to the fact that the adjectives *historical* and *historic* show semantic overlap – which arises from the fact that the noun *history* is itself ambiguous.⁹⁵

On the one hand, *historical* can refer to anything that has taken place in the past, possibly with a limitation confining it to exactly those prior events which have been documented in some written form – hence the distinction between *history* and *prehistory*, even though historical linguists often try to determine prehistoric(al) states of affairs and, to that end, propose specific reconstructions (see chapter 1 by RANKIN) or statements of language relationships (see chapter 4 by CAMPBELL). For many scholars who would describe their field as

“historical linguistics”, one legitimate target of research involves a focus not on change(s) over time but on the synchronic grammatical systems of earlier language stages. This practice can be called (not unrevealingly) “old-time synchrony,” and it has made its mark in the form of numerous studies providing synchronic analyses of particular syntactic constructions, word-formation processes, (morpho)phonological alternations, and the like for individual earlier (pre-modern or at least early modern) stages of languages. Thus, for example, Sommerstein (1973) treats the synchronic phonological system of Ancient Greek. Gaining as much synchronic information as possible about an earlier stage of a language must surely be viewed as a necessary prerequisite for doing serious work on the diachronic development of a language: as noted above (in section 1.2.3.1 regarding “vertical” comparison, and see also n. 59 and section 1.2.1.6), it is through the comparison of two stages of a language that we get a glimpse of what has changed (or remained the same, as the case may be). Nonetheless, pursuing the synchrony of earlier language states solely for the sake of (synchronic) theory-building (e.g., discussing proposed global rules in syntax based on agreement patterns of Ancient Greek, in the manner of Andrews 1971), as worthy a goal as it may be, does not count as doing historical linguistics in the literally *dia-chronic* (through-time) sense that we wish to develop here. At least in a technical sense, then, *diachronic linguistics* and *historical linguistics* are not synonymous, because only the latter includes research on “old-time synchrony” for its own sake, without any focus on language change.

But we must now bring in the term *diachronic* again for a comparison with *historical* vis-à-vis their individual combinations with *change*. In this regard, we would argue that it is perfectly legitimate to talk about *diachronic change*, since change indeed takes place through time (or at least is evident from a comparison of states across time) and also since change over time needs to be distinguished from diachronic stasis and/or stability. What we find unnecessarily misleading, however, is the phrase *historical change* (cf., e.g., Pinker 1994: 489), since change itself can never be banished to some historical (i.e., temporally distant) stage of a language. Rather, change is always instantiated over a period of contemporary time – that is, over a series of synchronic states which constitute a succession of present moments. The result of a change could indeed be talked about as something historical, but the process of change itself is always unfolding in some present moment(s) for some speaker(s). Before leaving this topic, let us return briefly to the above-mentioned assumption that, if it is legitimate to speak of *diachronic change*, then it is equally reasonable to talk about *diachronic stability*. Regarding the latter concept, we would like to stress that, as reflected in chapter 5 by NICHOLS, it is just as important – even if this is traditionally a lesser concern for historical linguists – to consider what in a language does not change through time, not just what does change.

Juxtaposing *historical* and *history*, we note that a linguistic diachronician may encounter both of the expressions “historical linguistics” and “language history” (on the earlier use of latter term, albeit from a slightly different vantage point from that assumed here, consult Malkiel 1953). According to one

common view, doing historical linguistics in the sense of looking at earlier linguistic stages and making comparisons between and among them can also lead to studying language history: that is, the history of a particular language or languages – a kind of glosso(bio)graphy, so to speak. Such information generally forms the basis for our understanding of language change in general. There thus necessarily exists a link between language change and language history, even though the study of language change can be pursued without any need to venture very far, temporally, from the present – as shown by the work of Labov (along with his students and other collaborators) on urban American English in the latter half of the twentieth century and the beginning of the twenty-first. That is, one does not have to be very historical (much less historic; see below) to be a historical linguist. The field is open (as it should be) to both studies of language history and studies of language change.⁹⁶ We might then say that historical linguistics is about the linguistics of history and the history of languages, and includes all that those two areas encompass.

On the other hand, there is an additional moral latent in the fact that the English word *historical* (attested since the fifteenth century) is also sometimes used to mean (or at least to connote) the same thing as *historic* (attested since c.1607), hence roughly “famous or important in history, having great or lasting significance, known or established for an appreciable time.” Thus, for example, in the American Automobile Association (AAA) of Ohio’s *Home and Away Magazine* 21.2 (for March/April, 2000), there is a vignette (p. 65) with the punning title “Historical Descent.” This description initially raises the expectation that what follows will relate either to someone’s having had a prominent ancestor or to a famous exploit involving downward movement (say, an early aviator’s momentous landing, or a spelunker’s record drop deep into the earth). But the text that then follows turns out to present simply a description of a hike down into Heritage Canyon (near Fulton, Illinois), where an open-air museum in a former quarry preserves old buildings moved there mostly from neighboring sites. The descent at issue is undeniably *historical*, since it has to do with local history, but it is hardly *historic* in the sense of being either generally significant or well known, even though the phrase *historical descent* which is at issue here readily invites this inference. On the other hand, *historic* is occasionally used with the meaning ‘relating to (or having a) history,’ as on an intriguing sign outside a Central California town which orders passers-by to “Visit historic Templeton!” Since Templeton (population 800) does not rate a “Points of Interest” entry in recent editions of the AAA’s *California . . . [Nevada] Tourbook* (over 1200 pages long, in its 1999 update), and since the town (located between Atascadero and Paso Robles) no longer even appears on *Tourbook* maps (as it did in the 1992 edition), but receives only an “Accommodations” listing (for two restaurants), it does not seem at all like a place connected with events of general significance, famous or infamous.⁹⁷ Templeton, California, then, is *historic* only in that, like everything else in universe, it has a history, or else it would not exist. Current use of the adjectives *historical* and *historic* is thus indeed somewhat mixed up, and hence can be misleading.

We do not, however, mention this potential confusion mainly because it illustrates semantic variation or change in contemporary English. Rather, we do so because it provides one of the few explanations available for why certain scholars sometimes appear to interpret *historical linguistics* as if it were *historic linguistics*,⁹⁸ the study of languages only insofar as they have either undergone momentous changes or been spoken by communities which have produced people and achievements famous in history: for example, the Athens of Pericles, the Rome of Augustus, or the England of Shakespeare, Chaucer, and whoever composed the epic poem *Bēowulf* ('*Bee Wolf*,' whose hero's vulpine ferocity is matched by a stinging sword).⁹⁹ That is, a survey of all the books and articles written up until now by historical linguists would arguably reveal an extreme bias in favor of Indo-European languages – and, within that family, in favor of Classical Latin, Classical Greek, the literary monuments of earlier stages of English, and similar foci in other "languages of culture," as they are sometimes self-promotingly termed. For instance, any readers who attempt to find an introduction to linguistic diachrony that does not exemplify haplology by citing Latin *nūtri-trix* > *nūtrix* 'female nourisher, nurse,' or else older English *Engla lond/land* > *Englond/England* 'Angles' land, England,' will find that even a consultation of Crowley (1997: 42), with its intended "Pacific bias" favoring especially Austronesian and Indo-Pacific Australian languages (p. 10), is going to let them down.

Yet, as we have already stressed in the several of the preceding sections (1.2.1.4–1.2.1.6), this skewing imposes on the study of language change not only (i) self-defeatingly narrow horizons (via the elimination of so many language families and languages where change indisputably takes place) but also (ii) artificially binocular-sized perspectives within those already limited horizons (via the exclusion of non-standard varieties and even colloquial styles). It is true, we confess, that the last century and especially its latter decades have seen historical linguists pursuing a historic trend toward an increasingly strong focus on non-(Indo-)European languages and on non-standard, non-formal varieties. Still, the non-academic public apparently remains convinced that the older literary monuments of classical tongues and standard languages should be the focus of diachronic linguists, and this can have repercussions even for research on ongoing change in modern colloquial English. The *Wall Street Journal* reported in 1980, for example, that then vice-presidential candidate George H. W. Bush, after hearing about a large NSF grant awarded to Labov and his colleagues at the University of Pennsylvania for the study of local speech, exasperatedly asked in public why anyone would care how people talk in Philadelphia. It seems safe to draw the historical inference that Vice-President and later President Bush did not agitate for increased funding of quantitative variationist sociolinguistics during his 12 years in or near the White House.

But, just as the philosophical study of events has elicited the comment that "[e]vents need not be momentous: the fall of a sparrow is as much an event as the fall of the Roman Empire" (cf. Mackie 1995: 253),¹⁰⁰ so linguistic diachronists

have everything to gain from promoting the view that the texts which comprise their subject matter are often most revealing when they are not historic, but only historical. It must therefore belong to the mind-set of those who study language change to believe (with apologies to W. C. Fields for exploiting what is popularly believed to be but is in fact not his epitaph; cf. Burnham 1975: 123; Boller and George 1989: 26; Rees 1993) that one linguistic interest of George H. W. Bush – and in fact of every George Bush – actually should, on the whole, rather be in Philadelphia: in how people talked there in 1980, and how they talk there now. Even a traditional literary classic like Shakespeare's 1599 *Julius Caesar* (in act III, scene 2) implicitly warns us that broad-based investigations are necessary because the determining influence on future English (or any other standard language) may come from a region, "many ages hence . . . [, having] accents yet unknown." Because it is precisely such broad coverage – of change as well as of variation – at which the determining plan of the present work aims, we follow the next section with a compact overview of this volume and the papers in it, organized by topics rather than by page numbers.

1.3 *On time*

[W]hat is time? . . . Who can explain it easily and briefly? Who can grasp . . . [it], even in cogitation, so as to offer a verbal explanation of it? Yet . . . what do we mention, in speaking, more familiarly and knowingly than time? And we certainly understand it when we talk about it; we even understand it when we hear another person talking about it. . . . What, then, is time? If no one asks me, I know . . . [,] but, if I want to explain it to a questioner, I do not know.

Aurelius Augustinus (St Augustine), *Confessionum libri 13* "(13 Books of) Confessions" (c.400; critical edition 1934/1981), trans. Vincent J. Bourke (1953)

The besetting sin of philosophers, scientists, and . . . [others] who reflect about time is describing it as if it were a dimension of space. It is difficult to resist the temptation to do this because our temporal language is riddled with spatial metaphors . . . [: e.g., we say,] "Events keep moving into the past" . . . [But] events cannot literally move or change . . . [,] as Smart (1949) . . . asserted, things change, . . . [but] events happen. . . . Those who spatialize time, conceiving of it as an order in which events occupy different places, are hypostasizing time. What we perceive and sense are things changing. Time is a nonspatial order in which things change.

C. W. K. Mundle, "Consciousness of time," in Edwards (1967: VIII, 138)

With a saintly scholar like Augustine already on record as expressing extreme uncertainty and even anxiety about attempts to define time, it would seem that, perhaps apart from formal semanticists, no linguists – not even historical linguists – should announce their intention to characterize temporal concepts without first recalling the saying (from part 3 of Pope's 1711 *Essay on Criticism*)

that “fools rush in where angels fear to tread.” Still, we believe that a certain amount of work on language change has been and still is bedeviled by an insistent though usually unspoken adherence to an arguably misleading and ultimately indefensible assumption about time: namely, that what modern-day historical linguists – and other historians – directly study (in whole or in part) is something called “the past” which exists elsewhere than in the present. While there is much to criticize in this view, we also take seriously the proverb that warns: “What’s sauce for the goose is sauce for the gander.” Thus, precisely because we are convinced that pernicious consequences beset the view – perhaps even the majority opinion – that linguistic diachronicians are engaged in direct study of a non-present “past,” it behooves us to outline an alternative approach, even if this should turn out to be a minority perspective that is itself greatly in need of elaboration and refinement. In this section, then, we begin by presenting some remarks on the general nature of time; we then bring these notions to bear on questions of linguistic change and reconstruction.

Devout respect for St Augustine’s thoughts on time has not stopped later generations of scholars from continuing to address this topic at length. For example, an International Society for the Study of Time has existed since 1966, holding conferences and publishing proceedings at quite regular intervals (cf., e.g., Fraser and Lawrence 1975.). Hence we disclose no secrets in admitting that even authors in tandem can find time to achieve only the barest sampling of the vast pertinent literature. In atonement, our sole recourse here is to highlight, from among the seemingly endless list of available works, a useful sample of the writings that we have found most cogent. For perhaps the best overview of the literature on time and the broad range of issues involved, see Fraser (1966) and references there. Other helpful anthologies include Gale (1967), van Inwagen (1980), Healey (1981), Swinburne (1982), Flood and Lockwood (1986), Le Poidevin and Macbeath (1993), Oaklander and Smith (1994), Savitt 1995, and Le Poidevin (1998). In turn, virtually all the papers in these volumes themselves list additional references, and some of the books’ editors have annotated their lists of further readings (cf. especially Le Poidevin and Macbeath 1993: 223–8). As for concise single-authored works, among those most valuable to us have been Whitrow (1961, 1988), Mellor (1998), and, despite its unusual title, Nahin (1999) – all with extensive bibliographies – plus, especially as a historical overview, Turetzky (1998).¹⁰¹

Without seeking to one-up Augustine, we must in all fairness confess that it is much easier to say what time is not than to say what it is. In line with this, we here devote only the barest programmatic remarks to a positive characterization of time, whereas we offer a much more extensive negative critique of certain commonly held competing approaches. Yet, from the etymological sense of definition (i.e., *de-fin-ition*) as marking off ends (*fin-es*) and hence setting limits, it follows that the act of establishing what something is not can also play an important role in defining a thorny concept. At any rate, in essaying to state what time is, we are most persuaded by an overall perspective whose defenders include, among many others, Mundle (1967), who equates time with

change – a view already quoted at the outset of this section (recall “Time is a nonspatial order in which things change”) and who thus concludes (p. 138) that “[o]ur consciousness of time’s ‘flow’ is our consciousness of things changing.” Similarly, Mellor (1981: 81, 1998: 70) emphasizes that “. . . [c]hange is clearly of time’s essence” (cf. also the similar treatment adopted by Le Poidevin 1991).

This change-based approach has the merit of facilitating a direct, non-circular account of a central temporal distinction – variously labeled “before” versus “after,” or “earlier” versus “later” (with non-relativistic simultaneity being definable as their joint negation) – which is crucial for any attempt to characterize the directionality of time (cf. also Reichenbach 1928; Earman 1974; Horwich 1987; Mellor 1991; Savitt 1995; Price 1996; and references there). This advantage derives from the fact that ordering in time can be equated with the structuring of changes, because changes are inherently associated with processes, while the latter, in turn, inherently possess an asymmetrical internal organization which is related to matters of cause versus effect. Moreover, given that processes can be interlinked either via overlapping (where portions of two processes are also associated as co-parts of a third process) or via proper inclusion (where two micro-processes co-occur within one macro-process), the totality of such complex and chained processes corresponds to (i.e., “covers”) the connectedness and continuousness of time, since there will never be any moment at which “nothing is going on anywhere.” (Take a moment to consider, in this regard, how staggeringly many processes involving subatomic particles must be active in the universe at every instant, even for entities ostensibly “at rest”!¹⁰²) In Mellor’s (1998: 118) words, “the causal theory of time order . . . makes the asymmetry and irreflexivity . . . [of ‘earlier’ and ‘later’] follow from the fact . . . that nothing can cause or affect either itself or its [own] causes.” This theory “also tells us why the direction of time has no spatial analogue, since . . . causes have effects in all spatial directions.” On such a view, we need not even assume that time exists independently and thus provides a dimension in which processes can take place; rather, we may assume that processes and their structure define time and so can be said to constitute it.

Although it remains controversial, the above-mentioned causal theory of time – arguably anticipated by Greek and Roman philosophers (like Epicurus (c.341–270 BC) and his poetic interpreter Lucretius (c.95–52 BC); cf. Lucretius c.60 BC: 1.198–9, 2.670–1) – has clearly exercised a solid intuitive appeal during the past three centuries. After this viewpoint was first extensively laid out by Leibniz (von Leibniz and Clarke 1717), it was soon after revised by Kant (1781: 188ff), and it has now been further elaborated by modern scholars ranging from Earman (1974) to Mellor (1998). To this causal approach there corresponds a parallel theory in which the central asymmetry at issue is not between cause and effect, but instead between lesser and greater entropy – the latter being a measure of the randomness (i.e., chaos, disorder, etc.) among the part(icle)s of a system (for a general discussion, cf. Kaku 1995: 304–6). This perspective goes back, via Reichenbach (1928) and Eddington (1928), all the way to Boltzmann (1898: 257–8, and even 1872). Strikingly (and fortunately), Hockett (1985) hap-

pens to summarize and illustrate exactly this kind of entropy-based approach as part of a detailed discussion relating specific aspects of diachronic linguistics to general considerations in history and historiography. Hence we here quote an extended passage – from Hockett (1985: 328) – at least partly as a down payment on an implied promissory note (from the current authors to our readers) guaranteeing that the present section does, indeed, move from the generally temporal to the specifically linguistic (and historical):

If you are told that, of two observations made one second apart . . . [– their relative times] not being specified . . . [– one] found the air pressure at both ends of a closed chamber the same, while the other found high pressure at one end and zero at the other, you have no trouble inferring which of these states came first . . . [T]he second law of thermodynamics is only a statistical generalization, so . . . it is not . . . impossible for all the air in the chamber to rush suddenly to one end, but the probability of that event is extremely small, and you are surely right to make the more likely inference. . . . The example is trivial because . . . extreme, but . . . also . . . clear. The reference to the second law of thermodynamics is not out of place . . . [:] as Blum [(1968/1970)] says, it is entropy that establishes “time’s arrow . . .”[. Thus, e]very historiographic decision reduces to elementary inferential acts like th[e] . . . preceding . . . [, or else] it is not valid.

These considerations, being completely general, also apply fully to linguistic reconstruction, which is the ultimate focus of the present section. Hockett (1985: 328) therefore goes on to state that:

[i]n more general terms . . . [,] there is evidence for two states of affairs (or events), S_1 and S_2 , separated in time but not in space. It is known that one of these was succeeded by the other, but not which came first. Now S_1 is of type T_1 . . . [,] and S_2 of type T_2 . If there is empirical evidence that type T_1 can give way to type T_2 , but that the opposite order of succession is improbable, then, obviously, it is inferred that S_1 preceded S_2 ; similarly in the converse case. Sometimes there is no such evidence, or the probabilities are even, or it is not clear to what types S_1 and S_2 belong, so that no decision can be made . . . [I]f the probabilities do not strongly favor one order or the other, the historical inference for the particular case is correspondingly insecure.

From Hockett’s well-taken remarks on the necessity of recognizing the role of probabilities in historiography in general,¹⁰³ it is a short step to an important point about the nature of linguistic historiography – that is to say, about linguistic reconstruction. However difficult a concession it may be for historical linguists, they must in all honesty admit that it is virtually, perhaps even absolutely, never the case that the probability of full accuracy for a reconstruction of a non-recent past event is 1.0. Thus, even with regard to a form like the reconstructed stem for ‘father’ in PIE – *p̥ater-, a reconstruction which is widely accepted and surely believed in to a high degree by most practicing Indo-Europeanists – much remains indeterminate: for example, (i) whether there was any distinctive or non-distinctive aspiration on the initial stop, and, if so,

to what extent; (ii) exactly where in the mouth contact was made for the medial stop; and so forth.¹⁰⁴ Surely there can be no less indeterminacy in the reconstruction for 'name' in PIE, where the forms in the various languages match up reasonably well but still fail to agree in certain details.¹⁰⁵ Hence, the primary question here, far from being how close to 1.0 the probabilities of proposed linguistic reconstructions definitely are, is instead how close to 0 (zero) they might conceivably be.

1.3.1 *A skeptical challenge to the unreconstructed nature of reconstructions*

As a result, it has been proposed in all seriousness by Janda (1994a, 2001) that the asterisk as an indicator of reconstructed forms in historical linguistics should be abandoned in favor of a complex symbol roughly of the form $n\%$ (RN), where the variable n stands for a number showing the reconstructor's (or a later writer's) percentually expressed level of confidence in a particular reconstruction, while the parenthesized (RN) stands for the initials of the reconstructor's name (or of a later writer's name). In this revised notation, Schleicher's (1868) reconstruction of 'master' (i.e., 'powerful one') in a shape like PIE *patis¹⁰⁶ would presumably be reformulated as 99.9% (AS) patis by a revived Schleicher but as 0% (CW) patis by, for example, Calvert Watkins (cf. Watkins 1985: 52–3),¹⁰⁷ whose – and many others' – preferred alternative, *potis, we ourselves would in turn give as 90% (RDJ and BDJ) potis, owing to a number of uncertainties such as those expressed above concerning *pāter-.

That is, we do not doubt for a moment that it is well justified to reconstruct *some* PIE word meaning something like 'master' and having roughly the shape *potis, but it will most likely never, ever be possible – either for us or for our successors – to verify every detail in the phonetics of the reconstructed form, let alone its semantics. (For example, regarding its range of referents, we may legitimately ask whether the term at issue applied only to powerful adults, or also to powerful children, or even – metaphorically – to powerful animals or the like.) Hence we do not consider the $n\%$ (RN) label for reconstructed items to be in the least a facetious suggestion; indeed, such a notation would in fact be a first step toward devising a reliable index for indicating the degree(s) of (un)certainly associated with many specific proposed linguistic reconstructions. And extending this notational practice to every segment (or even every intrasegmental feature) in reconstructed forms would go a long way toward iconically reflecting the full extent of their iffy, diaphanous nature.

That such a percentual labeling for reconstructed forms has considerable advantages over simple asterisking becomes immediately apparent in cases where the reconstruction of a joint pre-*proto-ancestor* is made solely on the basis of two (or more) totally reconstructed *proto-languages*. This kind of reconstruction that goes back beyond (i.e., further back in time than) a given *proto-language*, via application of the comparative method to two *proto-languages*,

has been discussed as a procedure by – among others – Haas (1969). And it has been practiced to an extreme degree by so-called Nostraticists (cf., e.g., the discussion pro and con in Joseph and Salmons 1998, as well as Campbell 1998 and CAMPBELL's chapter 4 here). Comparisons of this sort are generally treated as if they were just like reconstructions based solidly on two sources of attested data. But if one proto-form that is less than fully secure (e.g., rated at only 70 percent, in the $n\%$ (RN) notation) is compared with another proto-form that is similarly less than fully secure (and thus again rated at only 70 percent), then the result is the reconstruction, not of a 70 percent certain pre-proto- (or even "proto-proto-") form, but rather of a form that is 49 percent "certain" – and so clearly has a score that is closer to 0 percent than to 100 percent. It is admittedly true in such instances that, if one piles up the asterisks, then the multiplicity of stars does iconically tend to suggest that there is (or should be) greater uncertainty among scholars as to the probable accuracy of the relevant reconstructions. The monograph on Indo-European (IE) /a/ by Wyatt (1970), for example, – though its focus is not on comparative but on "internal" reconstruction (cf. RINGE's chapter 3 herein) – uses * for reconstructed Proto-IE (PIE), ** for pre-proto-IE (PPIE), and *** for pre-pre-proto-IE (PPPIE); hence, in proposing a particular (and particularly static) prehistory for the root meaning 'drive; lead,' Wyatt (1970: 56) writes "*****ág-* > ***ág-* > **ág-*."

However, the rapid dropping-off of confidence which necessarily accompanies the act of reconstructing items from reconstructions alone is indicated much more accurately via the multiplicative effects of the percentual notation, since in principle a pair of reconstructed forms bearing respectively a %X and a %Y label can together yield at most a %X·Y-labeled pre-proto-form, where the product X·Y must necessarily be lower than either X or Y. (We presuppose that a reconstructed form can surely never have a value of 1.0, for full confidence.) In sum, the use of a(n) (un)certainty index for proto-language forms makes possible a far more realistic assessment of probabilities (i.e., the likelihood of actual prior existence) in cases where essentially "proto-proto-" forms have been reconstructed on the basis of two or more sets of already-reconstructed proto-forms. As indicated by the rapid drop-off of the percentual scores in such cases, uncertainty ramifies much more quickly at greater (= more profound) time depths when only proto-forms are used, according to the method of Haas and many Nostraticists, in order to base reconstructions on reconstructions (on reconstructions (on reconstructions . . .)).

Further, while many linguists limit their use of the term "reconstruction" to the positing of forms and constructions for linguistic stages from which no records survive, it is actually the case that even attested stages of languages require considerable interpretation and filling-in of details – as well as more substantial aspects. Hence virtually all historical linguistic research merits the descriptor "reconstruction." And, finally, it must be conceded (if one is truly honest) that the presence of *re-* in "reconstruction" presupposes a degree of certainty about the accuracy of proposals regarding earlier states of linguistic affairs which flies in the face of the (im)probabilities just discussed. To be blunt

about it, we do not so much “reconstruct” a proto-language as “construct” it in the first place (although subsequent revisions of such *cōnstructs* could perhaps be called *ré-cōnstructs*). In fact, it might be preferable, as a precautionary measure, for diachronicians to talk about “speculating” a proto-language (or part of an attested language state), rather than about “reconstructing” it.

We emphasize this point (at the risk of belaboring it) because some linguists engaged in linguistic reconstruction give the impression that they take their proposals to be 100 percent accurate, acting almost as if they believe that the original linguistic objects which they seek to reconstruct still exist somewhere, frozen in time at some other place or in some other dimension – which, if only it could somehow be accessed, would confirm their proposals.¹⁰⁸ But is this kind of cocksure certainty not tantamount to a belief in the possibility of time travel back to, say, the Pontic steppes in c.3000 BC (on one view of where PIE might have been spoken)? (cf. Harrison, this volume, section 2.2.)

As a result, we think it appropriate at least to touch briefly on the issue of whether time should be conceptualized and discussed in spatial terms (another topic which is perennially discussed in philosophical disquisitions on time) – partly because it intersects with the issue of whether or not so-called “time travel” is now or someday will be possible, and what that might (or might not) mean for historical linguistics.

1.3.2 *Time is not space (and diachrony is not diatopy) – but is time travelable?*

In order to explore time and space, and time as space, we return to the aforementioned matter of discussing what time is and what it is not. First of all, one must guard against the tendency (surely an understandable temptation) to confuse time itself with the measurement of time. Thus forewarned, one can more readily see that any and all references to durations such as picoseconds, nanoseconds, milliseconds, seconds, minutes, hours, days, months, years, centuries, millennia, etc. actually reduce to using phenomena that recur at regular intervals as a background available for correlation with other events. But, obviously (we say along with most but not all philosophers and physicists), time must surely involve more than the measurement of time, and to pick one method for measuring time is not to define time itself.¹⁰⁹ A second and much more relevant misconception about time, however, arises from unconscious but no less real reductions of time to space. Now, ever since shortly after they were stimulated by Einstein’s (1905) paper on special relativity (summarized and explicated in Fölsing 1997: 178ff), physicists have widely exploited the idea of “space-time.” As Minkowski (1908: 54) put it, “space on its own and time on its own . . . decline into mere shadows, and only a kind of union between the two . . . [can] preserve its independence” (for insightful discussion, cf., e.g., Greene 1999: 47–66 et passim). But physicists’ space-time is not the notion that needs cautioning against in historical investigations (linguistic and otherwise). Rather, there are quite a number of approaches to time which

either view events and times as “moving” (see, e.g., Williams’s 1951 much-cited critique of “The myth of [time’s] passage,” i.e., the view that time literally passes (by)), or, what is worse, treat times as if they were places. It is this latter perspective which, we argue, is most pernicious for historical linguistics, because it appears to provide the unspoken premise behind certain proposed reconstructions whose presupposition of eventual verification in fact (or at least of verifiability in principle) would otherwise have no leg to stand on.

The problems that attend this view of time as place are numerous; we mention only a few of them here. For one thing, there is a matter of consistency. Though it is incompatible with the dominant view that the past is by definition over and gone, the opinion that the past (still) exists somewhere as a place is admittedly not without adherents, but how could the future exist as a place if it has not yet happened, and thus presumably could not really be located anywhere (at least not yet)? Also, if individual times were places, would it not then be the case that revisiting (“reliving”) the past would involve flitting from temporal location to temporal location? If so, how would a time traveler physically continue into the next state that lies ahead of the state currently being visited, since that next state would itself be a place with its own location?

And what would be the length – the temporal duration – of such individual states? If they are short enough (say, one picosecond in duration), could a visitor see anything significant happening there? With all the traveling in-between states, would this perspective on time not be even jerkier than watching the frames of a movie as if they were a fast slide-show? Or would the individual states themselves be long enough to have their own temporality (their own internal time structure, with events happening before versus after one another)? Would a visitor to state X alter it in some substantive way, and thus create a state X’? If so, where would the latter be located, and would the visitor instantly enter such state? Where, in fact, would any state of this sort have its existence? If the relevant location is “in some other dimension,” then what is the ontological status of this dimension? Much more specifically, if there actually should be some subpart of the past which is the place(s) where PIE “perdures” (as Michael Silverstein might say), how many temporal states does this represent? Would it be possible to reconstruct the range of variation surely extant in such a language from one individual time-state/place? What would ensure that a visitor to any such state would travel in the right sequence to one or more of the subsequent states? And so on and so forth.¹¹⁰

Given the multiple problems attendant upon the space-as-time approach (≠, to repeat, the relativistic notion of space-time), we here reject it – whereby we follow such similarly minded scholars as Smart (1949, 1955, 1967), along with the above-mentioned Mundle (1967) and Williams (1951). This conclusion renders impossible one major proposal on how travel through time might be possible, since some notion of past as place(s) seems to underlie the popular conception of how time travel could work – as a physical journey to some place(s) where past states continuously wait for out-timers to visit them. This is, for example, one interpretation of H. G. Wells’s (1895) novel *The Time*

Machine (recently refilmed), which ends with its narrator wondering whether the book's protagonist "may even now – if I may use the phrase – be wandering on some plesiosaurus-haunted Oolitic coral reef, or beside the lonely saline seas of the Triassic age." In this case, it would seem that, with the publicly declared bankruptcy of the spatial theory of time, there are no prospects that time travel could ever get off the ground.¹¹¹ But die-hard advocates of the view that linguistic reconstructions are somehow still verifiable in principle might continue to argue (or at least to assume) that, even if time is not spatial, time travel (of another sort) is nonetheless possible.

Although premising a short story, novel, or film on the possibility of travel through time can lead, in the best cases, to entertaining and even riveting plots, it is ironic that most writings or lectures by philosophers on the subject of time travel have the effect of making the reader or listener look repeatedly at his or her watch. Admittedly, there are certain works (some now almost with the status of classics) which are often discussed and thus bear mentioning here: for example, Earman (1974), Meiland (1974), Lewis (1976a), MacBeath (1982), Ehring (1987), Horwich (1987, 1995), Craig (1988), Flew (1988), Maudlin (1990), J. Smith (1990), Edwards (1995), Vihvelin (1996), and N. Smith (1997).¹¹² Yet we must agree with Earman's (1995: 268) assessment that "[t]he philosophical literature on time travel is full of sound and fury, but the significance remains opaque . . . [, and there is a rather narrow] focus . . . on two matters, backward causation and . . . paradoxes." Indeed, Earman (1995: 280–1) points out that:

[t]he darling of the philosophical literature on . . . time travel is the "grandfather paradox" and its variants. For example, Kurt travels into the past and shoots his grandfather at a time before grandpa became a father, thus preventing Kurt from being born, with the upshot that there is no Kurt to travel into the past to kill his grandfather . . . [,] so that Kurt is born after all and travels into the past.

– and shoots his grandfather . . . , thus preventing Kurt from being born. . . . From this kind of fixation on the part of philosophers of time travel, Earman (1995: 269n.3) draws the (surely correct) conclusion that "the philosophy of science quickly becomes sterile when it loses contact with what is going on in science."

Yet the reason why the preceding sentence is true, and why we echo it here, is – as Earman (1995: 268) points out – that, "[during the last few years . . . [,] leading scientific journals have been publishing articles dealing with time travel and time machines." For example, just in 1990–2, there were 22 papers on these subject, involving 22 authors, in such highly respected and rigorously refereed journals as *Physical Review D* (11 articles), *Physical Review Letters* (5), *Classical and Quantum Gravity* (3), *Annals of the New York Academy of Sciences* (2), and *Journal of Mathematical Physics* (1 article). That this continuing development is not better known outside of physics is partly due to the fact that some of these papers are camouflaged (intentionally so, though this is less often the case now) because their titles refer to "closed time(-)like curves [CTCs]" and

“closed time(-)like lines,” or “wormholes” and “causality (violation(s)).” But especially more recent articles are not afraid of titles mentioning “time travel” and, much more often, “time machines.”

In order to put some teeth into these assertions – with their obvious potential implications for students of language change – we need to provide some hard references to a set of representative articles by physicists which relate to the subject of time travel. Hence we give the following brief list of chronologically varied but mainly recent works: Feynman (1949), Gödel (1949), Everett (1957), Newman et al. (1963), Hawking and Ellis (1973), Tipler (1974, 1976a, 1976b), Morris et al. (1988), Aharonov et al. (1990), Frolov and Novikov (1990), Kim and Thorne (1991), Gott (1991), Hawking (1992, 2000, 2001), Headrick and Gott (1994), and Li and Gott (1998). Selecting just a few of these for more than nominal mention, we can begin with Feynman’s (1949) suggestion that the previously discovered positron (from *posi(tive elec)tron* – since it is the anti-particle of the electron) might really be, despite forward-looking appearances, an electron traveling backwards in time. But most later discussions have explored questions at a more cosmic level, and thus in connection with the curved space-times (related to the interpretation of gravity as the warping of space-time by mass) which came to the fore with the publication of Einstein (1916). Gödel (1949) thus proposed a solution to Einstein’s field equations for general relativity which was applicable to a rotating (thenceforth “Gödelian”) universe composed of perfect fluid at constant pressure – a place where space-time shows natural instances of closed time-like lines (of the Minkowskian “world lines” sort) which induced Gödel to conclude that “it is theoretically possible to travel into the past.”

Similarly, Tipler (1974) builds on earlier work to suggest that a long enough, very dense cylinder rotating with sufficient surface speed would allow the formation of closed time-like lines connecting events in space-time, reasoning that, “if we construct a sufficiently large rotating cylinder, we create a time machine.” Morris et al. (1988) invoke subatomic considerations and argue that the quantum “foam” filling space-time must contain tunnel-like “wormholes” allowing virtually instantaneous travel between the regions connected by them – regions existing in different time periods – so that time travel is probable under certain conditions. Aharonov et al. (1990), in turn, use a major principle of quantum mechanics (that certain particles can exist in various states simultaneously until they are observed) in proposing to build quantum-mechanical “balloons” which exist simultaneously in all their possible sizes and whose occupants must therefore simultaneously exist in many different rates of time – with this allowing particles to be sent into their own past. Gott (1991), on the other hand, showed for any two sufficiently long, dense, straight, but also extremely thin cosmic strings (presumed relics from the Big-Bang origin of the universe) that, if they approach each another from opposite directions and pass each other at high speed, then this should warp space-time via the formation of closed time-like loops encircling the two strings, thereby allowing observers to travel into their own past.

There are three reasons why there is no need for linguists, even diachronicians, to be at all put off or frightened by physicists' time-travel research along these lines. First, there are many books (and a few articles) which present excellent summaries and discussions of the above-mentioned articles and so make it less pressing to consult the original texts (or direct reprints thereof). Relevant here are, more generally, Hawking (1996), Parker (1991), Thorne (1994), Kaku (1994: 232–51 et passim), Price (1996), Novikov (1998), and Ehrlich (2001: 146–71 et passim), but most of all (because more specifically) Earman (1995) – as well as Pickover (1998) and especially Nahin (1999), a volume of awe-inspiring breadth and depth. Nahin (1997), on the other hand, is devoted to apprising literary authors that some of their ideas which were once only fiction are now science, and Simpson (1996) is a posthumously issued but (in general) still paleontologically sound example of a science-fiction novel by a major figure in evolutionary biology. Second, neither the conclusion that time travel cannot be shown on theoretical grounds to be impossible in principle (accepted by a large number of physicists) nor the stronger claim that time travel can be shown on theoretical grounds to be possible in principle (accepted by a smaller but still impressive number of physicists – though not, e.g., by Hawking 1992) forces us to believe that time travel as a practical reality is achievable at present or will be so in the foreseeable future. Third, even if the theoretical possibility of time travel should someday become realizable in the distant future, the earliest periods that will thereby become visitable are likely (on most theories) to be ones close to the departure date of the relevant travelers, and thus much *later* than our own time. Given their significance, we next briefly address the second and third points just mentioned.

As for establishing that practical considerations now render impossible even theoretically imaginable forms of time travel like the above-mentioned proposals from the recent physics literature, we believe that two observations should suffice. First, in the paragraph prior to the immediately preceding one, we have used the word *sufficient(ly)* in places where the original works used either the term *infinite(ly)* or an astronomically high number. Hence Tipler's (1974) rotating cylinder must be infinitely long and turn at at least half the speed of light, whereas the fastest speed currently achievable is less than one tenth of light speed. And Gott's (1991) passing cosmic strings not only must be infinitely long but also must (on one interpretation) move almost at the speed of light. Second, the infinities and astronomically great speeds (and densities) involved in these scenarios do not seem to bother physicists much, since the latter seem much more concerned with "the principle of the thing." Thus, for example, Nahin (1999: 370n.13) emphasizes that Gödel (1949) himself calculated the necessary speed of his potential time travelers as 71 percent of the speed of light and assumed that, if the needed rocket ship could "transform matter completely into energy," then the weight of the fuel would be greater than the rocket's weight by a factor of ten to the twenty-third power divided by the square of the duration (in rocket time) of the relevant travel as measured

in years. But Gödel's point, as Nahin (1999: *ibid.*) stresses, was that, despite the "formidable numbers" involved, "they require no violation of physical laws, and that is what really . . . [would be needed] if time travel is to be disproved."

For present purposes, then, the finding that time travel is both completely impracticable now and also likely to remain so for quite some time means that historical linguists can heave a mixed sigh of relief and disappointment. On the one hand, individual diachronicians of language can be fairly sure that the linguistic work on past times which they have achieved at second hand (i.e., at a later date, usually a much later one) will probably not be drastically overthrown by a returning time traveler who has had first-hand experience with the same speech-community. Neither do historical linguists need to fear that their best work will be obviated if a traveler back in time succeeds (as long as the usual paradoxes can be avoided) in inducing the speakers of the relevant speech-community to adopt new changes – say, as innovations common in speech (and thus audiotapable by the time traveler) but never used in writing – which contradict the way in which the language has been reconstructed from documents. Nor, lastly, is there any reason for Indo-Europeanists to torture themselves with the thought that the ancestral language to which they devote so much time was not wholly an outgrowth of its earlier past, but instead might have arisen when, say, Eric Hamp passed through a time warp and (again *pace* the usual paradoxes) unknowingly created PIE by talking to speakers of some other language while he thought he was doing fieldwork on Albanian (which, at least in this fantasy, might originally have been a language isolate). On the other hand, the present and foreseeably future impossibility of time travel as a practicable option means that, as we have repeatedly stressed here, there is essentially no hope (barring rarities equivalent to the discovery and decipherment of Hittite) that any particular reconstruction of an unattested language (state) will ever be absolutely confirmed – that is, that Jane or John Doe will ever be entitled to write, for example, 100% (JD) *potis* for PIE "powerful" or the like.¹¹³

At the same time, the other (third) point mentioned further above – the probability that even the time travel which could become practicable far in the distant future would most likely be limited to visiting time periods which are closer to a traveler's moment of departure, rather than (to) today's present (2002) and/or earlier times – also bears some useful implications for today's diachronic linguists. Relevant here is the fact that many of the space-time-related scenarios for travel through time involve one person (or set of persons) who moves faster than another person (or set of persons). This is because, via the Einsteinian phenomenon of "time dilation," time progresses more slowly at higher rates of speed (i.e., time effectively compensates for motion) – indeed, for a person who could somehow travel at the speed of light, time would actually stop. But, for a relatively stationary person (or set of persons), there is no time dilation, and so someone traveling away from such stationary person(s) at near light speed would return to find that she or he in some sense represented their (slight) past, since less time would have passed for her or

him (as a traveler) than for the other(s). Yet, here, the traveler cannot meet up with her or his own past (in the sense of the time before she or he started traveling). Because similar phenomena tend to hold for many of the physicists' time-travel models listed above, the strong overall trend is that these scenarios generally are incapable – even theoretically speaking (quite apart from practical matters) – of taking anyone back into a past prior to today's present (2002). There simply seems no earthly way for Indo-Europeanists to gain direct access to their ancestral object of interest, even by time travel.¹¹⁴

Yet, as we have already mentioned several times in previous sections (and will stress again at the end of this entire introduction), there are already independent reasons to study the present as a source of information regarding language change, given that (i) we have greater and more varied access to the present than to any other time, and (ii) all that one has to do in order to have the present turn into the past is to wait. In a nutshell, then, this relatively brief consideration of the possibilities of time travel within modern space-time physics has shown that even this once-science-fictional (but now theoretically science-factual) phenomenon still does not permit access to the language states which constitute the primary interest of most historical linguists, but instead provides an additional reason to concentrate on the present as a valuable source of data bearing on linguistic change as well as linguistic variation. But, as for the possibility of absolutely validating reconstructions proposed for, say, *c.*3,000 BC, *c.*5,000 BC, or even longer ago, it is this fond hope which is most likely to remain the stuff of films and novels. Still, it is revealing to return one last time to the matter of why the data of such ancient times (as well as of more recent ones) are so much less accessible to us, and especially why it is not possible to reconstruct (verifiably) the past in anything close to its original detail – since, if we could do so, we truly would be entitled to claim that a certain past time and state now exist (again) in some place.

A resolution to this question begins to emerge once we concede that, for all its humor, *The Hitchhiker's Guide to the Galaxy* (Adams 1980) is entirely correct when it emphasizes (p. 76) just how “vastly hugely mind-bogglingly big” the universe is – and not just how big space is, but how much there is in it. That is, we need only consider, for a given instant, (i) the total number of all the subatomic particles within all the atoms in all the molecules of the entire universe and (ii) the fact that this universe of particles can be viewed as standing in some overall relation to one another. It is beyond belief that this whole universe of particles could possibly be identically configured at any two moments, given the complexity and sheer volume of what would have to remain constant (and the ante is only upped further if we bring in anti-particles, on which cf., e.g., Greene 1999: 8–9). Once we delve into micro- as well as macro-levels, therefore, it must be the case that, from each instant to the next, the universe is changed into a unique new state. Thus, for an earlier time to be (re)constructed as a place, or to be fixed so as to be visitable as if it were a place, one would really have to realign every bit of matter at every level and every state of energy (even those entities, like gases, which are defined, in

their ideal state at least, by random movements of constituent particles). The implications of this conclusion surely are directly relevant for all forms of scientific and historical study, among them historical linguistics.

We turn once more to Hockett (1985: 336) for a characteristically insightful observation in this regard:

Some . . . events . . . are in principle unobservable in detail. If . . . [one] spill[s] a bowl of sugar, is it possible to have recorded the exact positions of all the grains in the bowl before the spill so that, afterwards, they can all be carefully picked up with tweezers and restored exactly to their former positions? If . . . [one] pour[s] a spoonful of sugar into . . . [one's] coffee, can any record be made of the exact sequence in which the grains – or the molecules – dissolve? Can one label a molecule without destroying it? Can one determine the exact number of cells in a particular human brain, or the exact number of stars in our galaxy? . . . As we contemplate smaller and smaller things, or more and more numerous aggregates, we pass eventually through a hazy boundary beyond which precise determinations are both impossible and unimportant . . . [–] *because* they are impossible.

The view of time that is most consistent with these observations is the one in which time is basically a process – or collection of processes – transforming one state of the universe into another (an approach that should be acceptable even to the many linguists who do not otherwise posit transformations, since it does not really involve movement from one state to another). But, if time is indeed the continual transformation of states via processes, then it can also quite justifiably be described as literally destructive (or, at a minimum, deformative) in its consequences, since time's effects make the universe as a whole unrestorable from one state to the next, at least given our current understanding concerning the (un)likelihood that substantial portions of the particulate universe will be manipulable by human or other agents in the foreseeable future.

That is, taking seriously the vastness of the universe and of all the matter in it makes it clear why restoring or recreating the past, as well as conceiving of it as a fixed place to be visited in confirmation of hypotheses formulated in the present, is impossible and really no more than an illusion. This last point is especially important, because it gets to the heart of what we do as historical linguists, and what we actually study when we do historical linguistics. We thus end this section with a closer consideration of this very point.

1.3.3 *Whence reconstruction?*

There clearly exists a strong human inclination – of nostalgic origin, perhaps – to try to recreate or at least glimpse the past: consider, for example, the willingness with which laypeople (i.e., non-linguists) accept such notions as the reputedly unchanged survival of Shakespearean (= Elizabethan or early Jacobean) English into modern times somewhere in the Great Smoky Mountains of Tennessee or on a remote island off the Virginia Coast.¹¹⁵ Some such drive,

it appears, is what leads so many linguists – and so many historians in general – to attempt reconstructions of the past. It is also clear that a minimum of reasonable inferences can indeed be made about the past, including the linguistic past; sometimes, indeed, historical material is available that seems to provide a direct “window” into (or at least onto) the past. We have in mind here such phenomena as the aftermath of cataclysmic events like the eruption of Mt Vesuvius in AD 79 or certain kinds of shipwrecks. Regarding the latter, it is particularly appropriate to cite the description by Goodheart (1999: 40) – since, in the opinion of that author (a polar opposite of this introduction’s two authors in his degree of historical confidence), “everyone agrees that”:

for all intents and purposes, the deep oceans remain a closed time capsule. And every indication is that it is an exceptionally rich time capsule – archaeologically as well as monetarily. The value of shipwrecks generally, besides what they have to tell about maritime history, is that, unlike most land sites, each freezes in time a particular moment of history, the moment of its sinking. Each is, in a sense, a small-scale Pompeii. And . . . [.] like the ash of Vesuvius, the ocean can, under certain conditions, be an extraordinary preservative environment. This is especially true in its cold, lightless depths, where fewer destructive microorganisms live, and where wrecks lie mostly beyond the reach of storms, trawler nets, and scuba divers.

For all their vigor of expression, though, Goodheart’s assertions pale next to those of many archeological works designed to appeal to general readers. For instance, the dust-jacket of Nick Constable’s (2000) *World Atlas of Archeology* confidently alleges that “[a]rtifacts, relics, bones, and ruins provide us with *first-hand* evidence and irrefutable proof of the practices of historic civilizations . . . [.] from the pyramids of Egypt . . . [onward]” (emphasis added). Here, one is tempted to respond that, yes, we can certainly have first-hand contact with any of the relevant objects that have survived into the present – but by what means (other than time travel, which we have seen to be currently a practical impossibility) could we gain literally “first-hand evidence of . . . historic civilizations”? Similarly, in 1998, as part of their “Ancient Voices” series, a consortium of the BBC, The Learning Channel, and Time-Life jointly issued a video, titled *The Secret of Stonehenge*, whose accompanying description invites its viewers to see lost worlds “brought to life again through state-of-the-art virtual reality reconstructions, stunning location-filming and evocative reenactments.” Perhaps the makers (and viewers) of such productions think that, as long as enigmatic relics from earlier times are “brought to . . . life,” it does not really matter much whether such reconstructions and re-enactments closely correspond to – that is, bring *back* (to life or to cloned imitation) – anything that was once real and true.

In this regard, introductory books and films about paleontology tend to be more honest and up-front regarding the degree to which they reflect the filling-in of fragmentarily preserved remains via present-day conjecture. The following rather frank admission has been made (cf. Gibson 1999) by Tim

Haines, producer of the three-hour, 9.6-million-dollar BBC mini-series *Walking with Dinosaurs*, which was watched by 13.2 million British viewers (one fourth of the UK's population) and later shown in the US by the Discovery Channel (in April of 2000): "All paleontology requires you to interpret something that's dead. . . . This series is our best guess and the best guess of some very intelligent scientists" (the latter being eight well-known paleontologists).

It is not entirely clear why there should exist greater diffidence in paleontology than in archeology concerning the details of reconstructed entities, but one possibly relevant factor may be paleontologists' need to flesh out many extinct creatures based solely on remains among which few or no traces of soft tissues have been preserved. Thus, one can see (in museums) reconstructions of dinosaurs whose feathers and purple skin are clearly labeled as speculative in accompanying descriptions. This can be contrasted with current practice in so-called "anthropological archaeology," a tradition within which a work like Wells (1999) confidently maintains that the artifacts dug up from large pre-Roman settlements in Western and Central Europe suffice "to show just how complex native European societies were before the [Roman] conquest," with "remnants of walls, bone fragments, pottery, jewelry, and coins tell[ing] much about . . . farming, trade, religious ritual . . . [, and other aspects of] the richly varied lives of individuals." Here, there appears to be a stronger temptation to fill in cultural gaps by extrapolating from the wealth of ethnographic material known to be available from myriad nineteenth- and especially twentieth-century studies of contemporary peoples. In this regard (a point to which we return below), practitioners of linguistic reconstruction seem to show degrees of confidence closer to those of anthropological archeology than to those of paleontology.

There is another possible reason why paleontologists tend to be less vehement in promoting their reconstructive work, and this has to do with past embarrassments caused by (aspects or wholes of) detailed concrete reconstructions of some creature which were first confidently proposed but then ignominiously withdrawn. One of the most notorious cases of this sort has to do with the spike of *Iguanodon*, a large plant-eating reptile whose fossil remains were discovered in England in the 1820s and led to its becoming only the second officially named dinosaur (in an 1825 publication; for thorough discussion of these and related facts, see Wilford 1985: 27–31, 56–65, 78–84, 129–32).

British physician Dr Gideon Mantell, who (along with his sister) had found the fossils and who first described them, made two major wrong assumptions about *Iguanodon*: (i) he thought that the animal had walked on four legs, like an oversized iguana, and (ii) the fact that only one spike-fossil had been found led him to mistake the dinosaur's spiky thumb-bone for a horn. Mantell's drawings thus placed this spike on top of the snout, making the creature look like a rhinoceros, and his sketch was later taken as a blueprint when, in the 1850s, a sculptor was hired to "revivify . . . the ancient world" by shaping cement, stone, bricks, and iron into life-size restorations of *Iguanodon* and other dinosaurs. The resulting *Iguanodon* looked like a reptilian rhinoceros, with its

on-all-fours posture and a spiked horn for its nose – errors which remain for all to see today, since the huge sculpture at issue is still to be found in a park at Sydenham on the outskirts of London. Soon, however, Thomas Henry Huxley noted the resemblance of *Iguanodon*'s hindquarters and three-footed toes to those of birds, therefore arguing that this dinosaur must have been capable of erect posture and able to hop or run on its hind legs, a prediction that was eventually confirmed. In 1878, moreover, coal miners in Belgium stumbled on 30 nearly complete *Iguanodon* skeletons, from which it became clear that the above-mentioned spikes appeared in pairs and came from the front/upper limbs – since they were in fact thumb bones, not nose horns. Such cases of egregious (but fortunately only temporary) misreconstruction by paleontologists of the nineteenth century should lead us to ask whether there exist any rough parallels in the field of historical linguistics which can serve as similar caveats, especially because archaeology also has its share of corresponding examples.

For example, in an engaging conversation with an unusually knowledgeable interviewer – cf. Miller 1995 – which was published not long ago, Egyptologist and curator Emily Teeter (now also co-author of Brewer and Teeter 1999) mentioned (p. 9):

a famous boo-boo . . . in Egyptology . . . where things have been completely misinterpreted . . . [one involving some] little knives . . . which people used to say were ritual circumcision knives with a . . . wonderful mystique about them. It turns out they're just plain old razors for scraping faces. When you're not quite sure, the cult significance can get built up tremendously [so as] to make it fit into . . . [some] magical, mysterious sense of Egypt . . . If you spend enough time going through the publications or . . . the tombs, it's very likely you'll find a picture of somebody holding one of these things up. And very likely the pictures are accompanied by a hieroglyphic caption, just like in comic books. So if you're not quite sure . . . [.] you read the caption, and it says "razor for cutting hair."

In this instance, a mistaken interpretation involving the reconstruction of cultural behavior was avoided due to the fortunate discovery of label-like writing on or near (a picture of) an artifact. In cases where there are no (decipherable) inscriptions, however, archeologists (as well as diachronic linguists) are left rather in the dark, and their speculations are inherently less constrained. The attendant pitfalls are well enough known in Egyptology that scholars like Teeter find it salutary to challenge one another with occasional invocations of David Macaulay's satirical (1979) book *Motel of the Mysteries*, whose premise is that, sometime in the distant future, two amateur archeologists unearth an ordinary US motel and then proceed to misinterpret it completely by treating virtually every item unknown to them as a cult object – with a television set being analyzed as "the great altar" and a toilet bowl as "the sacred urn." Given that historical linguists are at least dimly aware of real gaffes nearly as extreme as these in the parallel fields of archeology and paleontology, can we ever be sure that some or even many of our linguistic reconstructions will not

turn out, in retrospect, to be outrageous or ridiculous? And, for that matter, are there any unmistakable tell-tale signs of an outrage- or ridicule-provoking reconstructed language form?

Actually, there are some fairly well-known reconstructive examples from the middle of the nineteenth century which are so extreme in nature that they now function almost as advertisements for how not to do reconstruction. As discussed, for example, by Kiparsky (1974b) at some length, the German classicist Curtius (1877) and certain earlier Indo-Europeanists (grouped by Kiparsky as “Paleogrammarians” in order to set them off from the later, better-known Neogrammarians) applied a kind of semantically based reconstructive operation to PIE. Thus, 1.pl. pronominal forms were assumed to be a conjunction of 1.sg. + 2.sg. pronominal forms, whereas the assumption for 2.pl. forms was that they conjoin 2.sg. + 2.sg. In addition, active-voice person-endings of verbs were treated as simply tacked-on personal pronouns, while the endings of PIE’s so-called “middle” voice were assumed (since the latter was a somewhat reflexive-like structure where a subject acts on his or her own behalf, and thus affects himself or herself) to be essentially double-pronominal, and so to consist of reduplicated active-endings.

Hence Curtius proceeded logically from the agreed-on 1.sg. pronoun and active-(ending) *ma*, and from the 2.sg. pronoun and active *tva* (the use of asterisks for reconstructions was not yet obligatory), to 1.pl.act. *ma-tva* and 2.pl.act. *tva tva*, and from there to 1.pl.mid. *ma-tva-tva* and 2.pl.mid. *tva-tva-tva*, with the latter two showing partial reduplication (of only the last element of the corresponding active-ending). In this, though, Curtius was distancing himself from August Schleicher’s (1861–2) even more repetitive-seeming earlier reconstructions (likewise semantically based), with their noticeably full(er) reduplications: cf., for example, the 1.pl.mid. suffix as Schleicher’s PIE *ma-tva-ma-tva*, or his even more relentlessly logical reconstruction of the PIE 2.pl.mid. suffix as *tva-tva-tva-tva*. Today, however, both Curtius’s and Schleicher’s reconstructive proposals of this sort stand out like a sore thumb; they are now viewed as rather bizarre. Yet, at the time, Schleicher did not hesitate at all to publish bold suggestions regarding reconstruction, and thus Schleicher (1868) caught considerable flak even from his Paleogrammarian colleagues (and especially from his Neogrammarian successors) for attempting to write a short fable in his version of (heavily Sanskrit-leaning) PIE, although some twentieth-century scholars have dared to follow his example (e.g., Hirt, as cited in Jeffers and Lehiste 1979: 107–8, and see also Lehmann and Zgusta 1979).

Admittedly, the above primarily semantics-driven nineteenth-century reconstructions stand out by their combination of length and brute-force repetition, but we believe it necessary to repeat the question: how do we really know today whether a given reconstructed form is accurate or even plausible? With no practical chance in sight for verification via time travel, most proposed reconstructions would in fact seem to be inherently incapable of direct verification – either pro or con. And this, in turn, explains the justification behind the suggestion that reconstructions are inversely related to treason. That

is, whereas Har(r)ington (1618, quoted from 1977: 255) penned the rhyme that “Treason doth never prosper: what’s the reason? / . . . [I]f it prosper, none dare call it treason,” we can turn this around as follows: “Reconstruction doth ever prosper; what’s the reason?/No one from the past returns to call it treason!”

Summarizing so far, then, we find that, despite the considerations discussed in this and the preceding sections, much current (as well as earlier) research in diachronic linguistics still harbors an implicit – even, on occasion, explicit – presupposition that reconstructions and historical inferences can somehow be definitively verified,¹¹⁶ and talk of allegedly “frozen” time states would certainly feed such a belief, as would the view (discussed in most detail in the previous section) according to which time states might have a spatial existence (if only in some other “dimension”). Yet, as discussed above, there will always be myriad aspects of the past which must remain unknowable, and hence verification can be at best a relativistic enterprise. Moreover, and more importantly, though, it needs to be asked just what is being studied in such “reconstructive” work – is the past really the object of study, or, rather, pieces of a present? Collingwood’s (1946, here quoted from 1993: 484–5) discussion of this point focuses on historians’ task in dealing with their evidence:

[Historical] records, which may be of various kinds – . . . [dispatches,] correspondence, descriptions by eye-witnesses or from hearsay, even tombstones and objects found on . . . [a] battlefield – are traces left by the past in the present. Any aspect or incident . . . which has left no trace of itself must remain permanently unknown . . . [,] for the historian’s business can go no further than reconstituting those elements of the past whose traces in the present [she or] he can perceive and decipher. . . . In this sense . . . [,] history is the study of the present and not of the past at all. The documents, books, letters, buildings, potsherds, and flints from which the historian extracts . . . all [she or] he can ever know . . . about the past . . . are things existing in the present. And . . . [,] if they . . . in turn perish – as, for instance, the writings of . . . historian[s] may perish – they . . . in turn become things of the past, which must leave their traces in the present if . . . [historians are] to have any knowledge of them. These traces must be something more than mere effects. They must be recognizable effects . . . [–] recognizable, that is, to the historian.

The general and especially economic historian Wallerstein (1974: 9) made this point even more bluntly: “The past can only be told as it truly *is*, not *was*” (original emphasis). In consequence, both linguistic and other diachronicians must label as actually unrealistic and ultimately unattainable the seemingly modest goal stated so famously by the nineteenth-century German historian von Ranke (1824: vi) when he said that a historian “just wants to say how it really was” (in the original: “Er will bloß sagen, wie es eigentlich gewesen [ist]”). Much more realistic – because much more aware of the later biases unavoidably imposed on reconstructions and interpretations of earlier times and things by historians, as well as private citizens – are the remarks of the urbanist and historian Rybczynski (1999: 32–4). Concerning certain gems

of eighteenth-century US architecture, that is, Rybczynski pointed out that “[f]amous houses like Monticello and Mount Vernon reflect . . . Virginia planters’ dreams of classical Rome, a reminder that a hallmark of the American house is a continuing reinterpretation of history . . . [– o]r perhaps one should say . . . [a continuing] reinterpretation of the past, a past that is both real and imaginary.” And reinterpretations (like language change) always take place in the present, ultimately on the basis (or at least under the influence) of present phenomena – a point made with admirable clarity, cogency, and concision in the following statement by Collingwood (1946/1993b: 110):

[H]istorical thinking . . . is . . . based on the assumption . . . that there is an internal or necessary . . . [connection] between the events of a time-series such that one event leads necessarily to another and we can argue back from the second to the first. On this principle, there is only one way in which the present state of things can have come into existence, and history is the analysis of the present in order to see what this process must have been.

In this regard, a useful caveat is provided by Bertrand Russell’s thought-experimental point that even events which we have personally experienced do not exist in some special past-space, but only in our present memories, and that these are subject to all sorts of interfering factors. Russell’s (1921: 159–60) dramatic example is worth quoting at length (with the original emphasis):

[E]verything constituting a memory-belief is happening *now*, not in that past time to which the belief is said to refer. It is not logically necessary to the existence of a memory-belief that the event remembered should have occurred, or even that the past should have existed at all. There is no logical impossibility in the hypothesis that the world sprang into being five minutes ago, exactly as it then was, with a population that “remembered” a wholly unreal past. There is no logically necessary connection between events at [non-contiguous] different times; therefore nothing that is happening now or will happen in the future can disprove the hypothesis that the world began five minutes ago. Hence the occurrences which are *called* knowledge of the past are logically independent of the past; they are wholly analysable into present contents, which might, theoretically, be just what they are even if no past had existed. . . . I am not suggesting that the non-existence of the past should be entertained as a serious hypothesis. Like all sceptical hypotheses, it is logically testable, but uninteresting. All . . . I am doing is to use its logical tenability as a help in the analysis of what occurs when we remember.

It thus cannot be overemphasized that, in studying the past, no scholar of any kind, whether historian or historical linguist, has direct access to past states; rather, the most that anyone can consult is those aspects of the present which can be interpreted as suggesting something about an earlier present which we call “the past.” When we reconstruct, therefore, we are indeed really dealing with the present and using it to speculate about the way things were in past

states. In this way, much of what any historian does is really akin to linguistic internal reconstruction (see again RINGE's chapter 3), since that methodology involves working back to past (earlier) linguistic phenomena on the basis of language data drawn from a later, more contemporary synchronic state – that is, from the historian's present, more or less.

Yet, even with this methodology, there are sometimes chasms that cannot be bridged. An instructive linguistic example is the history of Modern English *went*. If one looked only at *go/went* in present-day English, one might be inclined to think that there had been an earlier time when there was some other, less irregular pattern. For example, one might conjecture that *go* originally had no associated past tense (i.e., was a praesens-tantum verb), but that the accretion of the past form *went* onto *go* introduced suppletion into the picture. Or it might be speculated that *go* earlier had a (more) regular past-tense form of some kind, either a so-called "dental preterite" form similar to *goed* – often produced by children learning English as a first language – or a so-called "strong" (ablauting) form similar to, say, *gew*, which follows the *knew* of *know/knew/known* (compare *go*/. . . /*gone*). Otherwise, one would probably be most likely to think that the pattern *go/went*, being irregular, reflects the original state of affairs in earlier English and in the language state(s) ancestral to Old English.

Thus, any linguistic analyst with knowledge only of Modern English would be hard-pressed if called upon to deduce the truth here. This is, namely, that there earlier existed a different suppletive past form, as can be seen by comparing Old English infinitive *gān* (the ancestor of *go*) with Old English suppletive past-tense *eode* (with reflexes like *yode* which survived into Middle English before being ousted by what had originally been just the past tense of *wend*, as in *wend one's way*; compare *wend/went* with *send/sent*). That is, one suppletive paradigm has been replaced by another, without any trace of the earlier suppletive form surviving into subsequent synchronic language systems. Only the accident that information about the past tense of 'go' in Old English is still available today, in texts that have been preserved and studied – that is, texts which really represent facts about the present state of affairs concerning our knowledge of Old English – reveals this truth about that earlier state. Without specific knowledge of suppletive *eode*, nothing certain or even approximately accurate could have been achieved by conjectures that propose an ancestral form for the suppletive past-tense part of English *go/went* solely on the basis of internal reconstruction.

Besides the often insurmountable barrier posed by suppletions which replace suppletions, as in the example just summarized, there are two other problematic aspects of reconstruction that deserve at least brief mention (for discussion of other reconstructive difficulties, cf. such works as, e.g., the masterful study of etymology by Watkins 1990).

First, there is the problem of (non)simultaneity – which, given its intersection with notions like (linguistic) structure and system, receives far too little discussion in the literature on language change and reconstruction. The first horn of the dilemma faced by historical linguists on this score is that, given the

huge number of postulated proto-elements often involved in attempts to arrive at a reconstruction for an entire proto-language, there is often extremely little evidence available from attested, later languages or dialects as to the relative chronology of different reconstructed elements; that is, for any two reconstructed entities, whether (and, if so, for how long) they occurred at the same time in the proto-language – which should be no less characterized by shifting configurations of elements, especially lexical ones, than any modern or otherwise attested language. (There is, after all, no such direct evidence for (non)simultaneity available from the actual time of the real but unattested language whose reconstitution is being attempted.) Yet, on the other hand (and horn), when considerations of structure and system are brought in as helpful factors for organizing the many and varied phenomena of a reconstructed language state, it is rarely obvious that the number of simultaneously present proto-elements which has been securely established is large enough to justify the conclusion that a particular system was present at any one time (and could thereafter serve as a guide for resolving the status of ambiguous elements, filling in gaps, and the like).

Typology is frequently appealed to, of course, as a way to resolve chronological and other difficulties of a reconstructive enterprise, but the abuses to which typology has been put in the name of reconstruction (especially for syntax) have already been emphasized here (in section 1.2.1.7). It must thus be concluded that the dilemma of proto-(non-)simultaneity remains a major bane of reconstruction efforts by historical linguists, and that probably the most common situation is for diachronicians to have evidence only that a certain number of reconstructed elements all probably have occurred in the proto-language at some point in time, but not necessarily the same point – so that, in unlucky instances, one is stuck with basically a laundry list of proto-items floating together in a temporal wash.

A second and much more general problem of reconstruction – albeit one which receives even less attention in the literature than does (non-)simultaneity – involves not a dilemma but a paradox. Namely, given the frequency and earnestness with which historical linguists tend to talk about seeking explanations for synchronic phenomena in the past, via diachronic investigations of change,¹¹⁷ it seems ironic that reconstructed proto-languages¹¹⁸ are the only language states which have no real past (since the only thing that can be immediately prior to a proto-language is another proto-language – arrived at via, e.g., internal reconstruction). One consequence of this fact-cum-irony is obvious and not infrequently commented on. That is, since virtually every attested language state having an attested subsequent history is known to show some linguistic variants which do not appear in any later language states, it must surely also be the case that virtually every proto-language must have included certain aspects of language which were not passed on to any of its descendants. But, in that case, such variants are inherently unrecoverable – although this would obviously not be true if (*contra hypotheses*) we possessed a past for the relevant proto-language.

Also relevant here, however, is the fact that using reconstructed entities to explain their subsequent reflexes (and the changes relating them) is essentially circular, because the (changes and) later forms which reconstructions (and changes) are sometimes claimed to explain are themselves the basis for the reconstructions (and attendant changes) in the first place. There is no way around this, of course – as had been said, virtually everything in science is ultimately circular, so the main thing is just to make the circles as big as possible. Nevertheless, we must still remind ourselves how easy it is to be misled into thinking that reconstructions and related changes provide an essentially complete explanation for their reflexes/consequences, whereas it would be much healthier for diachronicians of language to ask themselves more frequently: “What did I learn from carrying out this reconstruction of a proto-language that I really didn’t already know from studying the data found in its descendants?” We emphasize these issues because it is well accepted in non-linguistic historiography that the best explanations push inexorably from the facts of earlier times to the events of later ones, as it were, rather than pulling prior facts forward toward the present on the basis of already-known subsequent outcomes. This point has been made forcefully by Weinberg (1994b: xv) – as also via other forums – in a way that is directly relevant to issues of circularity and explanation in linguistic reconstruction:

A . . . special problem appears . . . to affect much of the literature on the . . . [Second World War]. It is too frequently forgotten that those who had choices and decisions to make were affected by memories of the preceding war of 1914–1918, not by the Cold War, the Vietnam conflict, or other issues through which we look back on World War II . . . [But t]hey did not know, as we do, how the war would come out. They had their hopes – and fears – but none of the certainty that retrospective analysis all too often imposes on situations in which there were alternatives to consider, all of them fraught with risks difficult to assess at the time. The [present work makes an] effort to present the war in a . . . perspective looking forward rather than backward, and to do so at least in part on the basis of extensive research in the archives . . . [– a pursuit which is truly] challenging.

Alas, in the case of proposals regarding proto-languages themselves (as opposed to their descendants), it is precisely archives which we do not possess. It was partly the fact that information about unattested earlier language states is so often extensively obliterated by subsequent changes which led Schleicher (1848–50: ii. 134) to speak of “history, that enemy of language” (in the original: “die . . . [G]eschichte, jene . . . [F]eindin der . . . [S]prache”).

The relative degree of this obliteration – this destruction (to which we earlier referred in section 1.2.1 above) – is in fact the critical element in the study of all diachrony, linguistic or otherwise. We have already referred to Hockett’s (1985: 336) observation that much of the past is unrecoverable partly because it would have been virtually impossible to record it all synchronically – recall his two related queries: “If . . . [one] spill[s] a bowl of sugar, is it possible to have recorded the exact positions of all the grains . . . before[hand] . . . so that . . .

they can all be . . . restored exactly to their former positions? If . . . [one] pour[s] a spoonful of sugar into . . . [one's] coffee, can any record be made of the exact sequence in which the grains . . . dissolve?" But the most extensive discussion known to us of these issues is that of Sober (1988: 3–5), who in fact actually compares the possibilities for recoverability (and thus, by implication, reconstruction) against the ravages of change in astrophysics, biology, and historical linguistics:

It is an empirical matter whether the physical processes linking past to present are information-destroying or information-preserving. Indeed, we must fragment the single and seemingly simple question of the past's knowability into a multiplicity . . . [of questions and] ask whether this or that specific aspect of the past is knowable. . . . [No] *a priori* argument . . . show[s] that . . . history must always be recoverable . . . [; w]hether this is true depends on contingent properties of the evolutionary process. . . . [T]he folly would be great . . . [if one] were to try to produce . . . some general philosophical argument to the effect that the past as a whole must be knowable . . . [solely on the basis of the present]. The history of stars, of living things, and of human languages, to mention just three examples, . . . [is] retrievable only if empirical facts specific to the processes governing each are favorable . . . [T]he pertinent questions are local in scope, . . . [and] the astronomer, the evolutionist, and the linguist can each address [these queries] by considering the discriminatory power of available data and [of available] process theories [– i.e., theories mapping from possible initial conditions onto possible subsequent ones].

In this regard, the question of information-destruction versus information-preservation is the central issue, and we therefore initiate the conclusion of this section by presenting Sober's (1988: 3–4) overall treatment of this matter, given its crucial bearing on reconstruction and in fact all aspects of the study of language change (original emphasis):

[M]apping from possible initial conditions onto possible subsequent ones . . . engender[s] a continuum of epistemological possibilities . . . which reflect . . . whether historical inference will be difficult or easy. The worst possibility, from the point of view of historical science, arises when the processes linking past to present are *information-destroying* . . . [, when] the present state would have obtained regardless of what the past had been like . . . [– since] then an observation of the present will not be able to discriminate among alternative possible pasts. However, if even slight differences in the past would have had profound effects on the shape of the present, then present observation will be a powerful tool in historical reconstruction. . . . The worst-case scenario . . . arises if the system under investigation *equilibrates* . . . [, like] a bowl . . . on whose rim a ball is positioned and released . . . [,] roll[ing] back and forth, eventually reaching equilibrium at the bottom . . . [–] after which nothing can be inferred about its starting position. . . . It is sometimes thought that historical sciences have difficulty retrieving the past because the systems under study are complex, or because theories describing those systems are incompletely developed. Although this is frequently true,

matters are otherwise in the present example. It is not the complexity of the system or our inability to produce an accurate theory that makes historical inference difficult in the case of the ball [in the bowl]. It is the nature of the physical process itself, correctly understood by a well-confirmed theory, that destroys information. The fault . . . is not in ourselves . . . but in the bowl. In contrast with this circumstance . . . is a physical system in which different beginnings lead to different end states . . . [e.g.,] a bowl contain[ing] . . . numerous wells, s[uch] that a ball placed on the rim will roll to the bottom of the well directly.

The major question facing us here, then, is whether or not there are effectively pits in the bowls of data on which the theories and methods of historical linguists are constrained to operate in particular instances. An honest appraisal of the typical situation in linguistic diachrony would, we believe, compel us to admit that our field is less often blessed with pitted bowls and more often cursed with pitted, lacunar texts that represent obliterated information. Yet yeoman efforts by students of language change have often achieved great coups even in the face of recalcitrant texts – for example, via recourse to detecting scratched-out letters by scrutinizing parchment in sunlight, or by using ultraviolet light and other, newer means by which technology can sometimes help us to thwart history’s apparent enmity toward language and linguists. Nonetheless, in all of this, one thing above all remains forever true: what we are engaged in at first hand is actually a questioning of the present for what it can tell us about the past, not an interrogation of the past itself.

Thus, any preserved document – even a film or an audiotape-recording (cf. n. 20 regarding an early film in American Sign Language and the general notion of “document”) – represents a present-day artifact from which we can infer information about the past. It simply happens to be the case that we are generally convinced that some recording media undergo less degradation over the course of time than certain other means for attempting to make linguistic texts (more) permanent. What we are explicitly denying here is that there are any objects or phenomena in the present which could even “honorarily,” so to speak, be considered as belonging to – that is, existing in – the past rather than the present.¹¹⁹ We can have glimpses on the past, yes, but only through present-day windows.

During the more than two centuries of its modern period, mainstream historical linguistics has tended to take the very view regarding the object of its study that we argue against in this introduction. We have thus attempted to refute it – or at least present a counterbalance to it – by emphasizing the diametrically opposed stance adopted here, so as to sound a caution against falling into what we see as a trap. At the bottom of this trap is, we feel strongly, a fundamentally misguided conception of what it means to deal with the past – one putting forth every indication that its adherents believe scholars to be capable of truly restoring the past, that the reality of the past is directly accessible, and that diachronicians can (and do) study the past literally and

first-hand. All of these points contribute to giving some scholars the feeling that, through their reconstructions, they are directly recapturing the past, instead of just formulating generally unprovable, even if compelling, hypotheses about past states, linguistic or otherwise. Yet, paradoxically, all such study really does involve dealing with the present, and so there is surely even more reason (than we have previously discussed) for diachronic linguists to cultivate a focus on language variation and change in the present for its own sake, as well as for the purpose of establishing baselines to allow the charting of linguistic developments in the future, when today's present will have become the past.

Even though we have taken issue, in this section, with various common practices in the field of historical linguistics, we accept full responsibility for the fact that these approaches figure quite prominently in numerous chapters of this handbook. Indeed, we would be derelict in our editorial duty if they did not do so, since the practices in question characterize the way in which much work in historical linguistics long has been, and still is, carried out by many productive scholars (diachronicians who clearly do not share our – possibly idiosyncratic – views on these matters), and since these same practices have, over the years, been used by researchers to achieve some truly stunning successes. That said, we now therefore turn, by way of introducing the main body of the work itself, to a more detailed consideration of the nature of this handbook: what it contains, what it omits, and how to use it.

2 Part the Second: Historical Aspects of the Linguistics in this Handbook

Thus saith the Lord . . . [:] Remember ye not the former things, neither consider the things of old. Behold, I will do a new thing; now it shall spring forth; shall ye not know it?

(Deutero-)Isaiah (c.585 BC), from the ["Authorized"]
King James Version of Bible (AD c.1611)

*Those who cannot remember the past are condemned to repeat it.*¹²⁰

George Santayana, "Flux and Constancy in Human Nature" (Chapter 12), from *The Life of Reason, Vol. I: Introduction and Reason in Common Sense* (1905: 284)

In the course of our discussion, in part 1 above, of central issues having to do with language and linguistics, change and history, or language change and historical linguistics, we have already had occasion to make reference to many of the chapters in the present volume. Still, more discussion of the book as a whole and of its contents is in order, and this part 2 is reserved for such matters.

2.1 *Reconstructing from absences – or, topics to be found elsewhere*

[S]he is not there . . . , and the entire world . . . seems a negative imprint of her absence, a kind of tinted hollowness from which her presence might be rebuilt, as wooden artifacts, long . . . [disappeared], can be recreated from the impress they have left on clay, a shadow of paint and grain. . . .

John Updike, "Harv Is Plowing Now,"
in *The Music School: Short Stories* (1966: 180)

Some books are undeservedly forgotten; none are undeservedly remembered.

W. H. Auden, "Reading," from part 1: Prologue, in
The Dyer's Hand and Other Essays (1962: 10)

Let us begin by briefly noting what this work does *not* include.¹²¹

For one thing, this volume contains no chapter devoted solely to lexical diffusion – the putative item-by-item spread of sound changes through the lexicon. Admittedly, this notion has quite a long and continuous pedigree, in that it was already implied, not only by Jaberg's (1908: 6) and Gilliéron's (1912) Schuchardt-inspired dialectological dictum that "Every word has its own history" (see Malkiel 1967 and references there), but also by some post-Neogrammarians' covert recognition in practice (as opposed to theory) that a sound change can be implemented sooner in some words than in others. (For an example, see Prokosch's 1939: 62–7 discussion of Hirt's 1931: 148–55 claims regarding the apparently inconsistent realization of Verner's Law in Gothic.) As a proposed major mechanism of phonological change, however, lexical diffusion was first specifically addressed by Wang (1969), then elaborated on by Chen and Wang (1975), and later discussed extensively by Labov (1981, 1994) as well as, among others, Kiparsky (1988 and subsequently). Our decision to forego an entire lexical-diffusion chapter reflects our belief that, while there often are diffusionary effects in the spread of phonological change through the lexicons of speakers, such effects are actually epiphenomenal, being the result of already-needed mechanisms of analogical change and dialect borrowing. Thus, in our view, lexical diffusion is not a separate mechanism of change, in and of itself.¹²² Still, it deserves mention in any handbook-format work on historical linguistics, and, indeed, it is not ignored here, though discussion of it is dispersed across four different places: see chapters 6 and 11 by KIPARSKY and HOCK respectively, as well as chapters 7 and 8, by HALE and GUY respectively.

Similarly, there is no single chapter here devoted exclusively to the use of typological information – already discussed above (in section 1.2.1.7) as a controversial reference point for reconstruction(s) – in investigations of language history and language change. Admittedly, a heavily typological methodology has been employed for reconstructive purposes by, for example, Lehmann

(1974), regarding PIE syntax, and, as noted earlier (in section 1.2.1.7), by Gamkrelidze and Ivanov (1972, 1984), Hopper (1973), and others, regarding the PIE stop system, but their proposals have been tellingly challenged: Lehmann's, by Watkins (1976) and others; Hopper's and Gamkrelidze and Ivanov's, by Dunkel (1981) and others (see n. 37). Still, discussion of these methods, at least in passing, finds a place at various later junctures in this volume: for example, in chapter 1 by RANKIN, and in chapter 2 by HARRISON.

That no chapter here directly addresses what some might consider the ultimate historical question concerning speech – the origin of language itself – is due mainly to the fact that it is not obvious how the standard methodologies of historical linguistics can currently offer anything to illuminate this issue.¹²³ Rather, an approach to this subject from a multidisciplinary perspective incorporating insights from archeology, cultural and physical anthropology, ethology, evolutionary biology, paleontology, primatology, and many, many other -ologies appears to be indispensable. And, even then, the results remain, of necessity, quite speculative. Still, we do not want to seem as if we wish to revive the famous ban imposed on the topic at issue by the Société de Linguistique de Paris in 1866. Hence we refer all interested readers to Carstairs-McCarthy (1999, 2001) for highly readable discussions concerning the origin(s) of language, and to Callaghan (1997) for a review of recent books dealing with the relevant issues. See also the more specialized treatments (focused on particular issues and/or adopting particular viewpoints) in Armstrong et al. (1995), Beaken (1996), Calvin and Bickerton (2000), Hurford et al. (1998), Jablonski and Aiello (2000), and Sykes (1999), as well as Hauser's (1996) much broader perspective in *The Evolution of Communication*; all of these works provide extensive references to earlier literature.

Further, due to an ommissive trend in the field that comes close to being a global gap, there is no discussion here of diachronic pragmatics per se – for example, of changes in the types of inferencing used by speakers to extract meaning from contextually embedded utterances,¹²⁴ or possibly in the frequency of direct versus indirect speech-acts within certain types of interactions, or the like. Nonetheless, some of the chapters in this volume do discuss various aspects of change that are closely tied to matters of real-world context and/or pragmatic setting, and so they offer at least a tip of the hat to historical pragmatics. For example, in chapter 20, by TRAUOGOTT, grammaticalization is approached with a focus on forms as used in discourse – and thus as rooted in pragmatic context – while, in chapter 21, FORTSON discusses changes in lexical semantics that have their origin in facts concerning alterations in the real-world use of words (or even in the real world itself). Still, diachronic pragmatics is certainly not as well-developed an area of research as many others treated more systematically in this volume – for example, phonological, morphological (especially analogical), and syntactic change – for each of which the relevant literature is vast and reflects well over a century of research.¹²⁵

There is one area of study that certainly has the potential to provide instructive examples of change involving pragmatics, but it is here subsumed under a

rubric which likewise receives little discussion in this volume, and for compelling reasons – ones having to do with linguistic characteristics that (outside of punctuation) are rarely, if ever, represented in writing. In particular, intonational change can often be linked with pragmatic factors, since pragmatic contexts are regularly (if not invariably) linked to the meanings and functions associated with particular intonational contours. Thus, the handful of existing studies summarized in Britain (1992) – including Ching (1982), Guy et al. (1986), and James et al. (1989); cf. also McLemore (1991) – are all initial contributions to an understanding of intonational change, though it is clear that much more information is needed about the form and function of intonation in prior language states before we can conclude that any interpretations assigned according to contemporary usage truly represent innovations vis-à-vis earlier patterns.¹²⁶ And intonation is far from being the only prosodic phenomenon which, because of its infrequent (direct) indication in writing, it is difficult for historical linguists to trace over time.

Thus, as an additional topic about which little is said here, prosodic change more generally (and not just intonation) should be flagged for an additional word of explanation. As noted above regarding intonation, this comparative gap stems partly from the relative paucity of relevant written evidence, in that there is often no marking in texts and earlier documentation to hint at what the full extent of prosodic information can be (a small sample would include length, moraicity, syllable- and foot-structure, stress- or pitch-accent, and tone). Still, there is admittedly no shortage of specific works on historical accentology and other aspects of prosody,¹²⁷ though general surveys are much fewer in number.¹²⁸ However, on the one hand, prosodic change seems fully tractable in terms of analytical methods and notions that, by now, are time-tried for other aspects of phonological change (e.g., the comparative method, regularity of sound change, social mechanisms governing the spread of innovations, etc.), so that there is no apparent need for a distinct subfield of “diachronic prosod(ology)” (though Page 1999 takes a somewhat contrary view). And, on the other hand, there is as yet so much to be learned about the physical realizations and formal patterning of synchronic intonational curves and other prosodic phenomena that we may actually still be in the same position that we are with diachronic pragmatics: that is, the present lack of data may enforce, at a minimum, one or two generations of waiting until two or more richly described contiguous points in time are available for comparison. Nevertheless, insofar as changes involving traditional prosodic phenomena like length are well or at least better understood, they are here dispersed among the various chapters on general aspects of phonological change.

In addition, there is no extended discussion here of glottochronology, a method which attempts to determine the length of chronological separation between related languages by comparing the extent to which they share “basic” or “core” vocabulary.¹²⁹ It is true that some textbooks on language change – for example, Anttila (1989), Lehmann (1992), Fox (1995), Trask (1996), and Crowley (1997) – include substantial sections or even entire chapters on the topic. Still,

we have been content to let the admittedly brief mentions in chapters 1, 2, and 4 – respectively by RANKIN, HARRISON, and CAMPBELL – suffice, due to our moderate doubts as to the utility of glottochronology, other than in very rare circumstances,¹³⁰ and our strong doubts concerning its basic premises. In particular, the method's crucial reliance on a relatively constant (average) rate of vocabulary replacement over millennia seems to presuppose that speakers somehow possess or can gain occasional access to a diachronic perspective on where they and their core-vocabulary items “are” (relative to earlier speakers and speech-forms) within a chronological span over which a certain number of innovations are expected – not too many more, not too many less. But we doubt that anyone has access to the historical information which would be needed in order to obtain and (unconsciously) act on such a perspective, and we are not aware of any external forces which could otherwise guarantee that vocabulary replacement should proceed at a constant rate over a thousand years.¹³¹

Mention of glottochronology brings to mind another, related area which, after some deliberation, we chose not to include in this volume: namely, the whole enterprise usually referred to as “linguistic pal(a)eontology.” This (sub)field has to do with how linguistic evidence can be brought to bear on (or be correlated with what is known about) cultural reconstruction – that is, it concerns the relationship between linguistic reconstruction and what is known (or at least believed) about the material culture of (specific) ancient peoples: what they ate, drank, and otherwise ingested, what their religious practices were, what forms of poetry and narrative they used, what their social organization was, and the like. A set of ancillary issues still often addressed by such investigations centers on attempts to determine the “*Urheimat*” (German for “original homeland”) of various groups: for example, how and why they migrated from this area and later settled where they did, whom they came into contact with, how long ago such movements took place, and so on. There is an extensive literature on such questions, and perhaps the best-known writings within it involve research into the lives and times of speakers of PIE – though, with regard to other linguistic groups, see, for instance, Siebert (1967) concerning the Proto-Algonquian homeland.¹³²

The allure of the past is strong, indeed, and work in these areas is of great interest not only to linguists but also to language specialists, anthropologists, historians, and prehistorians – as well as being intrinsically interesting in its own right, and thus possessed of considerable appeal for the layperson. Still, we ultimately decided not to include this topic in the present handbook, since it is a subject which focuses less on issues of language change per se, and more on the historical insights that one can gain into non-linguistic matters by employing the results gained from various applications of (both diachronic and synchronic) linguistic methodology. In that sense, it would have been less in keeping with the rest of the material in this book.

Finally, readers may be surprised to learn that this volume does not have a special section or chapter on pidgins and creoles, though THOMASON'S

chapter 23 deals with language contact in general. The latter apportionment reflects our view that contact must figure as a crucial aspect in any comprehensive treatment of historical linguistics and language change. At the same time, it is generally agreed that pidgins are not full-fledged languages, and we follow a recent trend in creolistics – see, for example, several of the papers in DeGraff (1999b), though also the contrary view in McWhorter (1998) – according to which creoles are treated as not qualitatively different from “ordinary” (non-creole) languages. The social and communicative conditions under which creoles arise are such as to compel great interest, of course, and, in certain ways, they show great temporal compression vis-à-vis more usual rates of change. Still, as far as the study of linguistic change is concerned, our belief that pidgins are essentially too different from non-pidgins, while creoles are basically not different enough from non-creole languages, has led us (admittedly with some qualms) to have the courage of our convictions, and so to conclude that neither of those two linguistic varieties deserves a privileged status in a work such as this.

2.2 *Constructing a present – or, topics to be found here*

That historians should give their . . . [home side] a break, I grant you, but not so as to state things contrary to fact. For there are plenty of mistakes made by writers out of ignorance, and which any [hu]man finds it difficult to avoid. But, if we knowingly write what is false . . . , what difference is there between us and hack-writers? . . . Readers should be very attentive to and critical of historians, and these in turn should be constantly on their guard.

Polybius, *Historiae* XVI. 14.6–8, 10 (c.150 BC), trans. after S. Morison (1968)

We live in a world already made for us but also of our own making . . . [– one] that has its clarities and its ambivalences. . . . These qualities of the world of the present, we must assume, were qualities of the world of the past . . . [To] ambition to tell what actually happened . . . [is to] ambition as well to describe the painful mix of force and freedom that life tends to be.

Greg Denning, *Mr. Bligh’s Bad Language: Passion, Power and Theatre on the “Bounty”* (1992: 5)

So, then: what does this volume include? Let us answer that query by considering, next, a selection of five key issues and controversies which fuel much research in historical linguistics and are addressed by several (non-overlapping) sets of chapters in this volume. In presenting this overview, we deliberately do not rehearse the well-known and influential listing of major questions that Weinreich et al. (1968) formulated, named, and discussed in their ground-breaking article of more than thirty years ago. Rather, the reader

is referred to that work, to Janda (2001), and especially to Joseph (2001b) for discussion and elaboration of the matters touched on there. The themes at issue here are as follows:

1 What is the role of children in language change? In particular, is it children who largely drive change, via the necessary (re)constitution of language that occurs when they acquire their mother tongue (due to the potential for reanalysis that such a process entails), or are children actually tangential to the personal forces and central arenas of interaction and language use which most strongly determine variation and change in languages? Substantial passages in chapter 25, by AITCHISON, as well as prominent parts of the contributions by HALE (chapter 7), LIGHTFOOT (chapter 14), PINTZUK (chapter 15), and especially FORTSON (chapter 21), discuss this matter to at least some extent – in a number of cases, with quite different answers being advocated.¹³³

2 What kind of relationship exists between externally motivated and internally motivated changes in language? As for the principles and constraints governing changes that emerge in situations of language-contact (discussed in chapter 23 by THOMASON) or dialect-contact (discussed in chapter 24 by WOLFRAM AND SCHILLING-ESTES), for example, are these the same as, or different from, those holding in situations which seemingly involve no outside influences beyond the resources that speakers have entirely at their own disposal? This is a long-standing debate, and it is made even more vexed by the added possibility of independent innovations on the part of different speakers (as with the slang use of *mo* discussed above in section 1.2.3.8).

3 What is the relationship of linguistic theory to linguists' views of language change? It is important to stress here that (as already briefly mentioned above, in section 1.1.1) one's view of what "language" is unavoidably colors one's view of what language change is. There exists something approximating what is intended to be a theory-neutral perspective on this matter,¹³⁴ in which language is viewed as a collection of utterances and words, potential and actual, and where language change is thus merely a change in that collection. But there also exists a more consciously theory-dependent perspective: hence, for structuralists, all language change is system change, whereas, for (some) generativists, all language change is rule change and grammar change, while, for (classical) Optimality Theoreticians, all language change is change in constraint rankings,¹³⁵ and so on and so forth. Comparisons between and among various views of analogy and morphological change are inherent in the juxtaposition of chapter 10 by RAIMO ANTILA with chapter 11 by HOCK and chapter 12 by WOLFGANG U. DRESSLER, while differing perspectives on phonological change lock horns with one another across chapter 6 by KIPARSKY, chapter 7 by HALE, chapter 8 by GUY, and chapter 9 by JANDA. Meanwhile, a panoply of views on syntactic change are brought into mutual close proximity in chapter 16 by ALICE C. HARRIS, chapter 14 by LIGHTFOOT, chapter 15 by

PINTZUK, and chapter 17 by MITHUN. All such juxtapositions here bear eloquent witness to the interdependence of general theoretical stances and specific views of language change; thus, for example, a functionally or semiotically oriented synchronic approach tends to go with a functional view of change, while a formalist approach to synchrony tends to correlate with a non- or even anti-functional view of change, to mention just two such correlations – even though these alignments are not strictly necessary.

Related to this point is the fact that, even though this is a book on historical linguistics, much of what is said here has great relevance for synchronic analysis. This is especially so in the contribution by GUY (chapter 8), where an understanding of change depends crucially on a recognition of synchronic variation, but also in that by MITHUN (chapter 17), since the syntactic changes discussed there make sense only if one views synchronic syntax as rooted in discourse structure. Similarly, an extension of the perspective taken by HALE's chapter 7, in which he argues for a purely phonetically driven type of sound change, could lead one to a view that, synchronically, the role played by the relatively abstract patterns of phonology is more limited than is usually assumed. Further, one premise of many studies involving grammaticalization, as illustrated here especially in chapter 18 by HEINE, as well as the contributions by BYBEE (chapter 19) and by TRAUOGOTT (chapter 20), is that grammar is an emergent phenomenon – that is, in the sense of Hopper (1987).¹³⁶ Generally speaking, we cannot avoid being reminded, in this regard, of a succinct statement in Joseph and Janda (1988: 194) which, by defining how synchrony and diachrony interrelate in such a way as to obviate the need for an independent theory of change, bears on the relation between a theory of language and a theory of language change. Moreover, no less a figure than Roger Lass (1997: 10) has declared that this passage “deserves quotation,” and so we feel justified (and not unduly immodest) in quoting from that study:¹³⁷

In denying . . . [the sharp distinction between] synchrony and diachrony, the view that there is only a panchronic or achronic dynamism in language suggests that there exist grammatical principles or mechanisms which direct speakers to change their languages in certain ways other than through cross-generational and cross-lectal transmission. To the best of our knowledge, however, there is absolutely no evidence suggesting that this kind of asocial individual causation of linguistic change really exists. But such questionable devices can be dispensed with on the usual view, taken here, that language change occurs solely via two independently motivated entities: the present (synchrony) and time (a succession of presents, i.e., diachrony).

Indeed, in Joseph and Janda (1988: 194), pursuing this line of reasoning further, we argued that “language change is necessarily something that always takes place in the present and is therefore governed in every instance by constraints on synchronic grammars.”

This claim that (in its short version) “language change always (and only) takes place in the present” receives surprisingly, even vanishingly little discussion

in the literature on either diachronic or synchronic linguistics. In fact, to the best of our knowledge, this view has rarely even been mentioned outside of such publications and presentations as Joseph and Janda (1988), Janda (1990, 1994a), Joseph (1992), Fischer (1997), and (less explicitly) Posner (1997: 2). Although this situation may simply represent one of those cases where a scholar should be tempted to say, “The very ubiquity of this belief within our field explains why so few publications ever refer to it,” we believe that this is unfortunately not the case. Rather, we fear that it just never occurs to most historical linguists that changes in language cannot legitimately be conceived of as happening elsewhere (or, to coin a useful new term, *elsewhen*) than in the present.

One reason for this may relate to an issue that has already been briefly mentioned above (in this section as well as in section 1.2.3.6): the overemphasis on child language acquisition among diachronically minded generativists of the 1960s and 1970s. After all, children’s acquisition of language is usually treated as a clearly synchronic phenomenon. Hence it is possible that diachronicians who have remained acquisitionophiles (like LIGHTFOOT, FORTSON, and HALE in their chapters here) may feel that there is nothing to be gained by affirming a more general “diachrony-as-sequential-synchrony” approach, whereas acquisitionophobes (like HARRIS, GUY, and AITCHISON in their chapters) may gradually have soured on synchrony-in-diachrony due to an acquired distaste for seemingly non-stop appeals to “the” language-learning child (cf., e.g., Allen 1995: 15, who “focus[es] on the language-learner as the locus of structural change”).

Still, we believe it more realistic to conclude that the main reason why most historical linguists fail to discuss language change as always occurring in the present is that they continue to focus on diachronic correspondences much more than on actual processes that lead to the innovation and adoption (or rejection) of novel forms. Since diachronic correspondences necessarily include one point in time which lies further back in the past than another, and since they often involve a second time point which is non-present, synchrony can easily disappear from sight when a historical linguist’s attention is fixed mainly on a past time without any compensatory strengthening of the realization that the period when a particular change happened was once the present.

Regardless of the reason(s) for its relative neglect, though, we insist on the cogency of the view that linguistic change is always present – in both senses. That is, ongoing variation-and-change is never absent from language, and it always occurs in the present – with obvious implications for (or, rather, against) any attempts to deny the relevance of change-related issues for synchronic analyses or to treat diachronic and synchronic linguistics as non-intersecting subfields.¹³⁸ We would only add here that the “present change” approach has an eminent pedigree. For example, it clearly is already implied in the words of the German sociologist Georg Simmel quoted above in section 1.2.2: “[O]ne does not need to distinguish between nature and history, since what we call ‘history’, if seen purely as a course of events, takes its place as part of the natural interrelationships of world happenings and their causal order” (1908,

quoted from 1957: 86). This view could even be said to have holy origins, given that another passage than that already quoted above (in section 1.3) from the *Confessions* of Aurelius Augustinus (St Augustine) leaves no doubt that the present is the only time whose existence is real, since “the past . . . does not now exist . . . , and the future does not yet exist” (c.400, quoted from 1981: 276, line 8). Still, in addition to considering whether language change is most closely linked with the present, the past, or the future, there is the logically prior necessity of establishing criteria for determining precisely when a change has occurred, as we briefly discuss next.

4 All of the preceding issues point to, and/or hinge on, the crucial question of when it is that we can talk about change: namely, does this moment arrive after speech-forms are altered by the first appearance of an innovation, or only after there has been some spread of that innovation? (Cf. section 1.2.1 above.) Moreover, if one presupposes that at least some spreading of an innovation must occur before a change can be said to have occurred, must the relevant spreading be to other individuals – and, if so, how many – or could a single individual’s increasingly consistent use of an innovative form be considered a type of spread (i.e., to additional linguistic and expressive contexts within that person’s spheres of usage) which shows the innovation not to be a one-time error or nonce-form, even if no one else ever adopts that innovation? Some authors here – for example, HALE in chapter 7 and FORTSON in chapter 21 – take the view that an innovation by itself (and it alone) defines a change, that this alone is all that diachronically oriented linguists need to be concerned with. On this view, spread is a matter for sociology, not for linguistics proper. Other authors, conversely – for example, GUY in chapter 8 – see spread as the defining mark of “real” change. While the latter position, already strongly advocated by Weinreich et al. (1968: 104–25, 188 et passim), was subsequently reiterated by Labov (from 1972a: 277–8 through 1994: 310–11), Labov has since moderated his position at least to the extent of emphasizing the role of “influentials” (influential individuals) in language change (cf., e.g., Labov 1997).¹³⁹

If spread defines change, then contact among speakers becomes crucial and the distinction between internally and externally induced change (see above) becomes blurred; the point of origination for an innovation may be internal or external, but in this view, its spread, via external, social factors, is criterial for “real” change. It then becomes a matter of some interest that studies of contact-induced change, as reported on in chapter 23 by THOMASON, have shown that anything can be borrowed, since the absence of constraints on externally induced change would suggest that there is no qualitative distinction to be made between internal and external change, given that there are no clear limits on what can happen internally as well. Similarly, it must be admitted (following Milroy 1993) that certain factors may promote innovations – in both internal and external change – that are individual, yet simultaneous and hence massive to the point of being global). Such situations mimic instances of local origin plus later spread: for example, if many individuals sharing the same language

as a common structural “filter” react in like fashion to the same contact stimulus, the effects will resemble both widespread diffusion of something borrowed by one individual or even many acts of borrowings by many individuals based on more extensive contact (see also n. 90 regarding the onomastic experience of Mr Warren Peace).

Before leaving this topic, we should mention that there may possibly exist a diametrical opposite to contact-induced change: namely, contact-induced stability. The crucial issue here concerns whether linguists (both synchronic and diachronic), in reasonably denying much efficacy to adults’ “corrections” of language-learning children, have not been led to downplay the effects – other than hypercorrection, on which see Janda and Auger (1992) and references there – of adults’ correcting other adults, and hence to underestimate the influence exercised by those whose advocacy of conservative speech-norms is active or even fanatical, like some teachers in compulsory schools or clerics who preside over daily churchgoing.

Although this topic must be saved for later research, we would briefly like to draw attention here to a relevant proposal made by Timothy Vance (1979: 116–17) in response to the finding that only 14 percent of his Japanese native-speaker subjects would extend to new (nonsense) forms the Japanese (morpho)phonological rule of so-called “sequential voicing” (*rendaku*, as in *ori* ‘fold’ + *kami* ‘paper’ = *origami*). Vance wondered whether this number might in fact represent the approximate percentage of the entire natively Japanese-speaking population who are in some sense committed to the *rendaku* rule – but with such fanaticism that they decide to become schoolteachers, usage commentators, and the like. Could this small band of dedicated *rendaku*-advocates, he asked, induce large portions of the general population to maintain sequential voicing as a regular rule of existing vocabulary, even though they cannot lead them to apply the rule productively? Of course, a complete answer to this question would require a full-fledged variationist study employing quantitative methods (in order to determine the extent to which the various social classes actually apply *rendaku* in more colloquial styles of speech). Still, suggestive evidence is provided by the fact that certain other (morpho)phonological alterations which are today found across all social groups and speech-styles were once much less widespread – until they received the strong support of grammarians and other academicians (e.g., cf. Janda 1998b: 351 for sources discussing variation between *vieux* versus *vieil* with vowel-initial masculine nouns in seventeenth-century French).¹⁴⁰

5 Finally, there are issues concerning the causation of change. Here, again, the topic of deciding the relative importance of system-internal versus system-external forces arises, but one can go beyond that basic question and pose more specific queries. For example, whether sound change is a matter more of articulation or of perception – that is, speaker-driven versus listener-driven – is addressed in chapter 22 by OHALA, and whether analogy is more structurally driven or semiotically driven (with a motivation rooted in cognitive processes)

is discussed in the chapters by ANTILA (10), HOCK (11), and DRESSLER (12). Finally, there is the question of whether syntactic change is a matter of alterations in abstract structures, as suggested in the chapters by LIGHTFOOT (14) and PINTZUK (15), or else rooted in the structure of discourse and thus tied to the unfolding of communicative acts in real time, as suggested in the chapters by MITHUN (17), BYBEE (19), and TRAUOGOTT (20).

2.3 *Synthesizing tradition and innovation – or, topics here in a new light*

A real tradition is not the relic of a past that is irretrievably gone; it is a living force that animates and informs the present . . . [–]implying . . . [, not] the repetition of what has been, . . . [but] the reality of what endures. It . . . [is] a heritage that one receives on condition of making it bear fruit before passing it on to one's descendants. . . . Tradition thus ensures the continuity of creation.

Igor Fyodorovich Stravinsky, *Poétique musicale sous la forme de six leçons* (1942: 39); trans. Arthur Knodel and Ingolf Dahl as *Poetics of Music in the Form of Six Lessons* (1947: 57)

Whether I think, on the whole, the French Revolution [1789–99] was a success? It's still too early to say.

Zhou En-lai (once a student in Paris, 1920–3, later prime minister of China), in an interview (c.1965) widely cited thereafter: for example, by the [Bloomington, Indiana] *Herald-Times* (December 8, 2000: A10), itself quoting Zhou from an editorial in the *Independent* of London on assessing the success of the Internet

Besides devoting particular recognition and discussion to the issues listed in the preceding section, the present work includes several features not easily found, if at all, elsewhere.

First and foremost, as the title *The Handbook of Historical Linguistics* shows, this is indeed a handbook (a manual) and, as thus conceived, follows the precedent set by an entire genre of works in historical linguistics – that of the traditional handbook – by aiming to sift through and sum up the received wisdom and accepted body of knowledge in a particular field. The institution of the handbook thus gives not only necessary background but also up-to-date, maximally definitive statements on timely major issues in the field. Moreover, the substantial bibliography is in itself a valuable resource for comprehending the breadth of the field as a whole.

Second, although this volume includes much that is traditional in historical linguistics – for example, the comparative method, internal reconstruction, dialectology, language contact, etc. – it attends equally to issues of more current relevance. Thus, the past decade's truly remarkable surge of interest in grammaticalization – a topic not even mentioned in, for example, the index closing Hock (1986), a widely used upper-level textbook – has resulted in the present book's including five chapters directly concerned with that

phenomenon – those by BYBEE (19), HARRISON (2), HEINE (18), MITHUN (17), and TRAUGOTT (20) – and further discussion of grammaticalization elsewhere, as well: for example, in chapter 13 by JOSEPH, in addition to those by FORTSON (21) and by HOCK (11).

Third, for most topics which have occupied historical linguists extensively over many years and which involve key areas of study in linguistics (especially sound change, analogy, diachronic syntax, and language comparison), this book's editors (as noted earlier, in section 2.2) have deliberately commissioned several chapters, rather than requesting a single summary statement from just one researcher. Also deliberate is the present juxtaposition of formal, functional, and/or variationist approaches to the study of particular subjects – which, by bringing in at least one representative of each differing methodology, gives a fullness of voice to each topic overall.¹⁴¹ It is in these ways that we have attempted to carry out our intention to ensure that multiple viewpoints are represented and that there is some internal dialogue between and among authors (as with the discussion by HALE in chapter 7 of the claims made by KIPARSKY in chapter 6 concerning sound change). Similarly, while there are entire sections of the volume dedicated to the examination of change as it affects one particular linguistic domain (e.g., for sound change, diachronic morphology, and syntactic change), brief but significant discussions of these areas are in fact also to be found in other parts of the volume. OHALA, for instance, in chapter 22, treats sound change within the section on causation, and JANDA, in chapter 9, discusses it within the section on morphological change. Hence, in actuality, the issue of causation is not restricted to the last section: both HALE in chapter 7 and FORTSON in chapter 21, for instance, discuss cognitive and acquisitional aspects concerning the causes of particular changes.

Fourth and finally, this book seeks to cover a broad range of languages, even though historical linguistics as we know and practice it today largely began with (i) the recognition of the Indo-European language family in general, after which came (ii) intensified research by nineteenth-century scholars into the nature of and relationships among the various Indo-European languages, including the branches into which they cluster. Though much work has by now been done on other language families, Indo-European studies still dominate the literature, and, indeed, Indo-European languages are well represented in this volume. At the same time, significant attention is paid in this work to native languages of North America (e.g., Algonquian, Siouan, Eskimo-Aleut) and to languages of the South Pacific (e.g., Austronesian), of the Caucasus (e.g., Kartvelian, Chechen-Ingush, etc.), and of Africa. Indeed, the language index for this volume is quite robust.

Thus, even with the recent flurry of publishing in historical linguistics,¹⁴² to the extent that the field seems to be enjoying a real renaissance (after what felt like years of neglect and marginalization within the overall field of linguistic science), there is still a need for such a volume as this one, with its combination of breadth and depth, of traditional background and current controversy.

3 Epilogue and Prologue

3.1 *Passing on the baton of language – and of historical linguistics*

Le tems s'en va, le tems s'en va, ma Dame, / Las! le tems non, mais nous nous en allons.

Pierre de Ronsard, from “Je vous envoye un bouquet . . .” (1555, original orthography; in *La continuation des amours* (1558), but suppressed, apparently due to its metrical unevenness, in the 1578 revision; reprinted in *Oeuvres complètes, Vol. II*, 1965: 814)

“Time goes, you say[; Time goes, you say, my Lady]? Ah no! / Alas, Time stays, WE go.”

Austin Dobson, “The Paradox of Time (A Variation on Ronsard)” (original emphasis), in the journal *Good Words* (1875), reprinted in Dobson (1923: 116)

Time is the substance I am made of. Time is a river that carries me away, but I am the river; it is a tiger that mangles me, but I am the tiger; it is a fire that consumes me, but I am the fire.

Jorge Luis Borges, “Nueva refutación del tiempo” (1947), trans. Ruth L. C. Simms as “A New Refutation of Time”

As the foregoing sections have demonstrated, our aim in conceiving the plan and commissioning the chapters for the current book has been the ambitious one of trying to be all things to all people – in terms of topics covered, languages discussed, viewpoints represented, and so on and so forth. We thus conclude these introductory remarks with an invitation – and a caveat – to readers of this volume. It should be clear that this work is primarily addressed to those who have at least some background in linguistics and/or the history of particular languages; such prerequisites belong to the essential nature of a handbook. In that sense, too, this is not a textbook and not an introduction. Still, we believe that this volume can be used for introductory purposes, especially for bringing in a diachronic perspective as a balance to the heavily synchronic (and non-diachronic) viewpoint assumed by most courses in linguistic theory and analysis. In this way, any reader who begins to gain a minimum of experience with linguistics as a field, in any subfield of the discipline, should soon find substantial portions of this book to be extremely relevant and highly informative. At the same time, there are many senses in which the level of presentation targeted by the current work is advanced enough that “professional” linguists ought to be able to benefit greatly from this collection of chapters – even professional historical linguists. Our expectation, therefore, is that there will indeed be something for all readers in this work.

At this point, however, there is no longer anything more that we can do here in pursuit of such a goal. The rest, as they say, is history – we mean this more literally than our readers might perhaps be tempted to think. The rest is history in the sense that what follows this essay should be – or at least can be – research in historical linguistics. As we presently reach the end of our introduction, it begins to belong simultaneously to our own past and to our potential readers' future. This juxtaposition of times by one pair of authors emboldens us to conclude by suggesting that a similarly paired set of joint approaches to the study of linguistic change is likely to guarantee the greatest possible success for both this domain and the field of linguistics in general.

From the discussions in several sections above, we believe it follows that the most productive way to study changes in language – either in some particular period(s) from the past or in general – involves a combination of efforts which can be achieved if more diachronicians will apportion their time more equally (say, 60–40 percent, if not 50–50) between investigating the linguistic history of earlier eras and investigating changes currently in progress.¹⁴³ In the eloquent words of Schlink (1995, quoted from 1998: 130): “Doing history means building bridges between the past and the present, observing both banks of the river, taking an active part on both sides.” After all, as suggested by our earlier recasting (in section 1.2.2.2) of the so-called “uniformitarian principle” as a principle of informational maximalism, we historical linguists have everything to gain from building up an inventory of well-studied present times which, as they cumulate into a store of well-studied pasts, will slowly but inevitably provide a more solid database for formulating and testing increasingly sophisticated hypotheses regarding language change. Yes, some of these hypotheses will turn out to be ridiculously wrong. But, we maintain, a scientific (sub)discipline cannot make significant progress by refusing to propose any generalizations until it has “gotten everything right.” As more hypotheses are made regarding linguistic changes in the future, students of diachrony will be forced to look more closely and alertly for evidence of innovations in particular linguistic and social contexts, and later hypotheses can still profit greatly (and not just in terms of morale) from the risibility of earlier ones. Perhaps it will seem at first as if we are merely engaging in alchemy, so to speak, but chemistry will lie just over the horizon. . . .

Thus, while it may be difficult to argue with Lass's (1980a) conclusion that historical linguistics as currently practiced is a discipline little capable of even *ex-post-facto* predictions (or, in the terminology of Thom 1975: 115, “retrodictions”) concerning what changes in language are likely to take place, we would argue strongly that historical linguists have yet to put their best foot forward. On this view, our goal should lie in exactly the opposite direction from Lass's (1997) call to study language change in terms of past linguistic structures themselves, rather than via reference to speakers (of any era). Instead, what we need are many more studies of many more groups of contemporary speakers. Indeed, far from concluding that a speaker-based linguistic diachrony has already tried and failed to elaborate an exegetic-hermeneutic methodology,

much less a deductive-nomological one, we would urge our colleagues to keep in mind what Captain John Paul Jones expostulated at the height of a naval battle on September 23, 1779 (during the American Revolutionary War). Asked if he was ready to surrender, Jones retorted: "I have not yet begun to fight!" (cf. Dale 1851, quoted from 1951: 173). Alternatively (supplementing Jones's answer in a more international vein), historical linguists could do worse than adopt the words attributed to Maréchal de France (\approx Field Marshal) Ferdinand Foch on September 8, 1914, during the First Battle of the Marne (at the start of World War I; here in translation): "My center is giving way; my right is being pushed back: the situation is excellent; I am attacking!"¹⁴⁴

However, just as there is no need for any diminution of the *esprit de corps* among students of language change, so also such martial metaphors should be tempered with an emphasis on the fact that cooperation among historical linguists of differing interests and expertise is also likely to be a *sine qua non* for future breakthroughs in linguistic diachrony. Our discipline will continue to be broadened with new specializations (e.g., when speech analysis reaches the point where 10,000 hours of spoken conversation can accurately be transcribed automatically, even across dialect boundaries – which will surely be possible before the end of this new century) and to be deepened via the further development of existing areas of expertise. But the study of linguistic change is also being eroded by the steady disappearance of positions once specialized for historical linguistics (e.g., in language departments). We therefore believe that it is closer cooperation among diachronicians of various sorts which will both hold historical linguistics together and ensure its greatest success. As the theologian Reinhold Niebuhr (1952: 62–3), albeit in another context, put it so inspiringly: "There are no simple congruities in life or history . . . [, due to] the fragmentary character of human existence. . . . Nothing that is worth doing can be achieved in . . . [a] lifetime. . . . Nothing . . . virtuous . . . can be accomplished alone." It is with such convictions in mind that we have dedicated this volume to the spirit of collaboration and cooperation in historical linguistics (see the preface preceding this introductory essay).

In short, less a division of labor than a sharing of labor by students of language change appears to be the most promising approach: a collaborative endeavor in which scholars across the spectrum of diachronic, psycho-, socio-, and general linguistics link forces to focus not on the past states of "old-time synchrony" (static non-diachrony), but on a combination of past changes (dynamic diachrony) and present changes in progress (dynamic synchrony).¹⁴⁵ It is undeniably true that much excellent recent work has been wrung from "the use of the present to explain the past" (\approx the title of Labov 1974/1978; cf. also Labov 1994).¹⁴⁶ But we would argue that the greatest benefit available from a revised interpretation of the "uniformitarian principle" as informational maximalism (see section 1.2.2.2 above) can actually be gained if we pursue the above-mentioned goal of accumulating a solid quantity of broadly detailed (and "thickly . . . described"¹⁴⁷) data from a succession of present times that starts now and continues into the future – with these "presents" thereby becoming

the past that will eventually allow us to explain a future (coming) present.¹⁴⁸ Someday, we are convinced, diachronicians will use the present (when it has become the past) to explain at least part of the future (when it has become the present) – just as, in some of Conan Doyle’s stories about him (e.g., “The Speckled Band” from 1891), Sherlock Holmes was able not only to explain past events but even to predict what was still to come.¹⁴⁹ Still, far from equating linguistic change with crime, we hasten to emphasize that, on the contrary, it is only the failure to devote adequate study to ongoing changes in language which deserves to be seen as criminal.

3.2 *Envoi*

We can only pay our debt to the past by putting the future in debt to ourselves.
John Buchan (Baron Tweedsmuir of Elsfield), “Address to the People of
Canada upon the Coronation of King George VI” (May 12, 1937)

If you cannot enter passionately into the life of your own times, you cannot enter compassionately into the life of the past. If the past is used to escape the present, the past will escape you.

Henry H. Glassie, “Meaningful Things and Appropriate Myths:
The Artifact’s Place in American Studies,” *Prospects:
An Annual of American Cultural Studies* 3 (1977: 29)

While this essay has not hesitated to criticize certain aspects of historical linguistic work, and while it has not engaged in forced optimism about cases where the possibility of our ever gaining much confidence about specific past phenomena seems weak, if not bleak, we want the overall and final impression left by this introduction to be an upbeat one of hope, expectation, and even exultant impatience. Linguistic diachronicians have done much in the past, but even the study of diachrony should be at most *partly in* the past (through an awareness of what our predecessors accomplished), rather than *wholly of* the past (in terms of the periods studied). In short, we believe that the greatest achievements of historical linguistics are still to come. For this reason, and because we see so much promise in the strategy of accumulating a set of closely described presents for future use as soon-to-be explanatory pasts illuminating a later present – and, just as importantly, because the major part of this *Handbook of Historical Linguistics* (the meat and potatoes, so to speak) still lies literally ahead of our readers – we would press upon you these words: Forward to the Past!

And yet, it still might be asked, should such a thoroughgoing reorientation of, and rededication to, the study of language change – as something that always occurs in the present – really be viewed as a tremendously urgent task? Perhaps, some might suggest (at least metaphorically), it might be best to appoint a large and diverse committee to reflect at leisure on the matter and

then report back, while the business of historical linguistics proceeds as usual in the meantime. But we could not disagree more: the proper time to investigate the intersection of language and active time is now. And, as for the urgency of this undertaking, we believe it best to conclude by citing a highly relevant parallel invoked in 1962 by an influential twentieth-century statesman, John F. Kennedy, just as we began this introduction with an 1862 remark (Lincoln's dictum that "We cannot escape history") by a nineteenth-century leader of no lesser stature. Kennedy drew attention to an incident in the life of Louis-Hubert-Gonsalve Lyautey (1854–1934), a soldier, statesman, and writer who was elected to the Académie Française in 1912, made a (Field) Marshall of France in 1921, and is remembered, among the many colonial administrators of his time, as unique in his respect for local institutions, especially in Morocco (Lyautey's tomb in the Hôtel des Invalides – not far from Napoleon's – bears inscriptions in both Arabic and French). Addressing an academic audience in March of 1962, Kennedy recalled: "Marshall Lyautey . . . once asked his gardener to plant . . . [a certain tree, but t]he gardener objected that the tree was slow-growing and would not reach maturity for a hundred years . . . [, to which t]he Marshall replied, 'In that case, there is no time to lose; plant it this afternoon!'"

I hate quotation. Tell me what you know.

Ralph Waldo Emerson, *Journals* (May, 1849), reprinted (1965: 141)¹⁵⁰

By necessity, by proclivity, and by delight, we all quote. . . . Next to the originator of a good sentence is the first quoter of it.

Ralph Waldo Emerson, "Quotation and Originality,"
in *Letters and Social Aims* (1876: 158, 169)¹⁵¹

NOTES

1 *Bunk* here means 'claptrap, drivel, nonsense; humbug; deceptive, empty, foolish, or insincerely eloquent talk.' But these senses arose via a radical semantic shift in – and subsequent clipping of – a word which had once been just a personal and place name: viz., *Buncombe* (ultimately from the transparent Old English compound *bune* 'stalk, reed' + *cum(b)* 'valley'; cf. Cottle 1978: 75 and Brown 1993: 223, 300, 506). This unusual etymology has a combination of two further

properties that is nearly unique and thus surely justifies granting pride of place to *bunk* within this first note in an extended general discussion of language change. The following summary draws on Bartlett (1877), Barrère and Leland (1897: 193), Holt (1934/1961: 42, 129), Morris and Morris (1977: 97, 283), Lighter et al. (1994: 315–17), and especially Hendrickson (1998: 111), plus Bryson (1994: 287, 379n.1); other senses and origins of *bunk(s)* are listed in some of these works, but more fully by Cassidy

(1985: 463–4). The near-uniqueness of “nonsense”-*bunk* lies in our knowing not only (i) the full name and the detailed identity of the person whose particular actions led directly to the semantic change at issue, but also (ii) the precise year, month, date, and even time of day when this person’s actions set the relevant change in motion. Namely, on the morning of February 25, 1820, Felix Walker – a North Carolina congressman from Buncombe County (where Asheville is the county seat) – subjected the US House of Representatives to a seemingly pointless and endless oration totally unrelated to the general topic then being debated in the House (the so-called Missouri Compromise, which included a limited allowance for the territorial expansion of slavery). When Walker’s colleagues interrupted him to request that he keep to the main topic at hand, he replied, “I am only talking for Buncombe” (in fact, his speech had been written some time before and was indeed intended to impress only his constituents back home). Walker’s answer was reported in many newspaper accounts devoted to the great debate in which he had, so to speak, taken part. Almost immediately, US English-speakers began to use the phrase *to be talking for Buncombe* with the meaning “to be talking flowery political nonsense,” and this was rapidly shortened to (. . . *talking*) *Buncombe* – with its noun soon variably spelled *bunkum* – and finally (during the 1850s) also to . . . *bunk*. Even by 1827, attestations show that the expression’s earlier sense of “bombastic political talk” had been extended to cover “any

empty, inflated speech clearly meant to fool people,” a meaning which appears to have become dominant by about 1845 and also occurs in British usage starting c.1856. Partridge and Beale (1989: 68) describe *bunk* as colloquial in the nineteenth century but standard in the twentieth. Lighter et al. (1994) make the important observation that *bunk*’s link with deception was surely influenced by the non-cognate word *bunco* (from the Spanish card-game *banca*; cf. *banco* “bank”), a term for a dishonest game of cards, dice, or the like. *Pace* Henry Ford, the achievements of historical linguists in ferreting out all of this information are anything but *bunk*.

- 2 That this is not merely a question of terminology – or just another illustration of the fact that, if you push down on a water bed at one end, it rises up correspondingly at the other end – is shown by the fact that those who favor the lumping together of morphology and syntax tend to view the result not as “morpho(-)syntax,” but essentially as “greater syntax,” within which (former) “syntax proper” constitutes “(greater) syntax *par excellence*” and (former) morphology is something of a stepchild. For such analysts, phenomena which could have received either a purely morphological or a purely syntactic account – in the earlier senses of these words – tend to get the latter kind of treatment, and this obviously has major consequences for diachrony as well as for synchrony. For further discussion, see Joseph and Janda (1988), plus Janda and Kathman (1992) and Janda (1994a), along with their references. (The need to show

that these issues are substantive and not merely terminological was impressed upon us by Barbara Vance.)

- 3 Furthermore, word structure is far from negligible even in grammatical accounts where sentence structure receives a plurality of attention: thus, for Modern Greek, Joseph and Philippaki-Warburton (1987) devote 47 percent of relevant text (119 pp.) to syntax but still 43 percent (108 pp.) to morphology, versus only 10 percent (24 pp.) to phonology. Even works of this sort may actually discuss a greater number of morphological patterns than syntactic ones, though this fact may be hidden because syntactic descriptions – with their sentence-length examples and frequently three-part presentation (= original and two translations: morpheme-by-morpheme and idiomatic) – inherently take up more space than morphological ones. In support of this conclusion, it bears mentioning that Joseph and Philippaki-Warburton were closely following Comrie and Smith's (1977) "*Lingua* Descriptive Studies: Questionnaire," in which the apportionment of guiding questions is as follows: morphology with 47 percent (30 pp.) versus syntax with 28 percent (18 pp.), plus phonology with 12 percent (8 pp.), lexicon with 11 percent (7 pp.), and ideophones with 2 percent (1 p.). And the ongoing LINCOM Europa series "*Languages of the World/ Materials (LW/M)*," with numerous 60- or 120-page grammatical descriptions, is organized according to an even more lopsidedly morphocentric plan: 25 sets of queries (nearly 70 percent) for morphology, versus 7 groups of questions (just over 19 percent) for syntax, and 4 (barely 11 percent) for phonology.
- 4 Regarding *cf.* here: partly for convenience (and welcome variety), but also in order to provide an iconic illustration of language change at work in a work on language change, we follow the growing practice of using *cf.* to mean 'confer, see' – taking it to abbreviate English (finally stressed) *confér* – even though its etymon, Latin (initially stressed) *cônfer*, actually meant (among other things) 'collect, compare, contrast.' But we draw the line at this point, and so do not join those writers of Modern English who, by analogy to *i.e.* and *e.g.*, use *cf.* as an alternative punctuation. In other disciplines, though, *cf.* retains adversative, even adversarial meaning, as Grafton (1997: 8) points out: "Historians . . . often quietly set the subtle but deadly *cf.* ('compare') before . . . [a citation of a work; t]his indicates, at least to the expert reader, both that an alternate view appears in the cited work and that it is wrong."
- 5 We are reminded here of the bon mot (known to us from Calvert Watkins's class lectures on historical linguistics at Harvard University during the early 1970s and at the Linguistic Institute in Salzburg during the summer of 1979) according to which – with reference just to "laryngeal theory" (see Lindeman 1970; Bammesberger 1988) and to the glottalic interpretation of its obstruent system (see Gamkrelidze and Ivanov 1972, 1973, 1984, plus n. 37 below): "No language has ever changed more during a short period of time than reconstructed

Proto-Indo-European during the 20th century.”

- 6 It is certainly true that many introductory works on historical linguistics spend some time giving an overview of selected key events in the history of the field, such as Rasmus Rask’s and Jacob Grimm’s formulations of the First Germanic Sound Shift or Karl Verner’s account of certain exceptions to Grimm’s Law, since these findings revealed important truths about the nature of sound change (see, e.g., Hock and Joseph 1996: ch. 2). Moreover, there are some surveys of historical linguistics that give considerable space to facts about the history of the field: for example, Anderson’s (1991) discussion of Pāṇini’s Sanskrit grammar (which was not, however, historically oriented) and Greek debates in the Classical period about the nature of language (though those discussions did have a bearing on matters of etymology). Hence we must stress that the present volume does not treat the history of linguistics, and there is no compelling need for it to do so, given that there already exists a sizable literature on this very topic. Relatively specialized studies dealing with the histories of particular periods, linguistic subfields, or countries include such representative works as Pedersen (1924), Aarsleff (1982), Anderson (1985), Hymes and Fought (1981), Joos (1986), Newmeyer (1986), Andresen (1990), and Matthews (1993). For conciseness and compactness, few article-length overviews can compete with Collinge (1994a, 1994b) and Koerner (1994a, 1994b). Among the numerous general book-length histories of linguistics that are

available for consultation, we call special attention to the following: Arens (1969; essentially an annotated anthology), Waterman (1970; extremely brief), Sampson (1980), Amsterdamska (1987), Robins (1997), and Seuren (1998) – all single-authored books – as well as three collections: Hymes (1974b; eclectic), Koerner and Asher (1995), and Aurox et al. (2000ff). Besides highlighting the two last-mentioned works, which are co-edited by E(rnst) F(rideryk) Konrad Koerner, we can at this juncture more generally incorporate by reference virtually the entire set of works written or edited by Koerner. For the latter’s formidable bibliography on this and related subjects, see Cowan and Foster (1989) and Embleton et al. (1999), plus the journal *Historiographia Linguistica* and many of the proceedings of the International and the North American Conferences on the History of the Language Sciences (ICHoLS and NACHoLS). Several useful compendia on personages in the history of the field should also be noted: Sebeok (1966), Bronstein et al. (1977), Stammerjohann et al. (1996), and Ohala et al. (1999: vi–vii, 75–126, plus, on institutions, 39–74, and, on other organizations and projects, 1–38), as well as the series so far instantiated by Davis and O’Cain (1980) and Koerner (1991, 1998).

7 Except where noted (as here), translations from non-English originals are our own.

8 Delbrück’s (1880) *Einleitung in das Sprachstudium* . . . seems to take a similar view, suggesting (p. 19) that Bopp’s organismal terminology involves obvious “metaphors . . . – very natural ones, too . . . [– and,]

probably, if anyone had called his attention to the point, Bopp would have acknowledged that . . . [.] in reality . . . [., mental] activities take place, not in language, but in speaking individuals." Conversely, (p. 42f), as for Schleicher and "the natural sciences . . . , . . . he really possessed considerable knowledge of them . . . [., being] especially versed in botany . . . [.; a]ccording to scientists who knew him, he was celebrated for his admirable preparations for the microscope, as well as for certain productions of horticultural art." That is, Schleicher was also an avid gardener, especially of cactuses and ferns; cf. Schmidt (1890: 415). Moreover, Tort (1980: 49) points out that, at the beginning of his years as a professor at the University of Jena (1857–68), Schleicher sat in on courses in physiology and botany, while both Desnitskaja (1972) and Koerner (1974: xiii n.13) present evidence that (in the words of the latter) "Schleicher consciously adopted both terms and procedures from the natural sciences, particularly biology." For further discussion and many additional references concerning Schleicher's organicism in his linguistics, see especially Desmet (1996: 48–81 et passim), but also Goyvaerts (1975: 39–44), who points to the Neogrammarian penchant for exceptionless sound laws as one legacy of Schleicher's natural-scientism. Jespersen (1894: 2–17ff), for his part (cf. also McMahon 1994a: 319–23ff), singles out Hegel as a major additional influence on Schleicher's views: for example, the latter's predilection for ternary distinctions, and his positing of prehistoric versus historic periods differentiated

according to criteria of (un)consciousness, progression/retrogression, conflict/stability, and the like. A final piece of evidence for the complexity of Schleicher's personality and thought comes from the fact that, in 1844 (during his early twenties), he developed a passionate interest in phrenology and proudly co-founded the second phrenological society in Germany (cf. Schmidt 1890: 403/1966: 376), though this new enthusiasm seems to have been bumped off rather quickly by an avid return to amateur music-making.

- 9 Even as linguistic organicism wilted away in France during the 1920s, there occurred an isolated efflorescence of at least partly similar views (cf. the discussion by Wils 1948: 135–9) in the later work of the Dutch linguist Jacques van Ginneken, whose 1929 article on the hereditary character (= the biological heritability!) of sound laws concluded (p. 44) by arguing that two related developments were essentially inevitable. First, he suggested that Schleicher's family-tree diagrams would eventually be reinterpreted in a literal, biological sense, thereby regaining a place of honor in linguistics. Second, he predicted "that . . . older expressions . . . like, e.g., *the life* or *the organism of spoken language* . . . [would] necessarily win back again a corrected portion of their old meaning." Although comments like van Ginneken's were explicit enough to exclude the possibility that merely a metaphorical use of a term such as *organism* (*Organismus*, in the original German) was intended, this was not the case for all writers of the period. Thus, while Hermann Paul might have been

expected to avoid even the slightest hint of the organicism which had been so roundly criticized by his fellow Neogrammarians, the first chapter of his most famous work (1880) uses the words *Organismus* and *Sprachorganismus* repeatedly (19 times on pp. 27–9 and 32). Apparently, though, these always have (despite the literal rendering in Strong's 1890: 6–9, 13 translation of Paul 1880) the metaphorically extended meaning "(cohesively organized) system" (rather than "organism" – or "organization," or "organ": for example, p. 15 refers to the "organization of mind and body" as *geistige . . . und körperliche . . . Organisation*, and p. 28 to the "speech organs" as *Sprechorgane*). Paul's avoidance of the term *System* "system" itself appears to reflect the latter's residual but strong connotations of "grandiose overarching speculative scheme" (see Burkhardt 1977), with which it had become tintured during the preceding 100–50 years, as the pendulum swung away from such schemes. Thus, Rudwick (1972: 94) describes "a new generation of naturalists['] . . . distaste for grand syntheses" like those of Buffon (1778), and Gould (2000: 116) comments on how Lamarck's "favored style of science" (e.g., in his 1820 foray into psychology) – "the construction of grand and comprehensive theories . . . [,] an approach that the French call *l'esprit de système* (the spirit of system building) – became notoriously unpopular following the rise of a hard-nosed empiricist ethos in early-nineteenth-century geology and natural history."

10 Both here and subsequently, we use "American" with apologies to our Canadian, Mexican, and

Central or South American colleagues (also believing that the other authors represented in this volume would concur with us), but there is at present no commonly accepted truly adjectival form for *United States* (or *US(A)*) in English – as opposed to, say, Spanish *estad(o)unidense* or French *éta(t)sunien* (≈ "United-Stat(es)-ian"). We ourselves advocate the wider adoption of *Usonian*, a term first promoted in the 1930s by the architect Frank Lloyd Wright, albeit mainly for a particular building style (see, e.g., Thomson 1999: 324, but also 14, 170, 258, 336, 339, 356, 383, 394, 398, 400). Wright explained *Usonian* as consisting of an acronym based on the first four initials of *United States of North America* plus *-ian*, but he credited the British novelist Samuel Butler (1835–1902) with its creation – despite the fact that an occurrence of the term in any of the latter's works has yet to be found.

11 This conclusion should not, however, be taken as vitiating the fact that biology can sometimes serve as a convenient metaphor (cf., e.g., Hock and Joseph 1996: 445–6) or as a hypothesis-generating heuristic – for example, as a source of suggestive parallels (like those drawn in Dixon 1997) – once we have gotten it straight that the only organisms which are centrally relevant to language are human beings. It is also worth noting that organicist metaphors apparently helped some nineteenth-century linguists to think of (a) language as a system by letting them treat it as "an organic whole" ("ein organisches Ganze"; cf. Windisch 1886: 325 on his late teacher Georg Curtius's use of this phrase) – see, too, the list in

Tsiapera (1990) – whereas many Neogrammarians were tempted, in this regard, to throw out the baby with the bathwater (at least in the view of Jakobson 1931). We do not follow Tsiapera (1990), however, in seeing nineteenth-century organicist linguists like Bopp as having been influenced primarily by the general “intellectual climate” of pessimism connected with Romanticism, whose emphasis on decay as a major force in life would somehow have led that movement’s advocates to analyze, for example, the loss of inflections as due to the deterioration of an aging organism. Indeed, Verburg (1950: 466) argues that “Bopp was very old-fashioned in his basic conceptions. At a time when the Enlightenment, Kantianism, and Romanticism were still very . . . actual . . . [up-to-date, “in”], Bopp still . . . [swore] by the theoretically exact scientialism of the rationalism of earlier days, which had been given up by th[ose] . . . movements.”

- 12 After some reflection, we have opted to follow the practice of scholars who continue to use *BC* and *AD* as qualifiers for all dates given in terms of years, decades, centuries, and millennia, rather than switching to the competing labels (*B*)*CE* (for (*Before the*) *Common Era*). In particular, we reject the allegation that *BC/AD* represents a partisan favoring of a particular theology. After all, since it is known that Jesus of Nazareth was born before the death of Herod the Great in 4 *BC* – cf., for example, Fuller (1993: 356–66, especially 356), Hoehner (1993: 280–4), Levine (1998: 470–4, especially 471), Reicke (1993: 119–20), and their references – then Jesus must have been born before or at least during 4 *BC*,

though this date obviously cannot have been literally four years before (the birth of) Christ. Further, the English vocabulary of calendrical terms is already broadly ecumenical, or at least multid denominational: for example, most of the terms for the months (as in many other languages) reflect names of Ancient Rome’s gods (Janus, Mars, Maia, and perhaps also Juno), deified rulers (Julius and Augustus), or religious festivals (the *Februa*, a feast of sacrificial purification). On the other hand, as admirably summarized by Whitrow (1988: 68–9), the institution of the seven-day week has a Sumerian and Semitic (Babylonian and Judaic) origin, while the ordering of the days within it has an astrological basis relating to planets and other heavenly bodies whose names again are connected with Roman deities (viz., the sun, the moon, Mars, Mercury, Jupiter, Venus, and Saturn) via their Germanic counterparts (including *Tiu*, *Odin*, *Thor*, and *Frigga*). For general discussion of these and related issues, see Whitrow (1988: 66–74) and Blackburn and Holford-Strevens (1999: *passim*).

- 13 We say “this world” because there are conceivable possible or virtual worlds without temporal constraints. For instance, the “world” of grammars as psychologically interpreted entities may be one such world, since it is possible to model grammatical systems as having simultaneous application of rules – even though, in the real world, precise simultaneity of sound changes affecting the same portion of a word (e.g., adjacent sounds) seems to be a rare event and is perhaps even impossible.

- 14 This position (that the past cannot be changed even by divine agency) is also that of orthodox Jewish theologians, according to Dummett (1964: 34). Dummett himself, however, adopts a different stance on the issue. Likewise in direct contradiction of Agathon's claim are at least seven medieval Roman Catholic philosopher/theologians (including one saint) who argued that a proper understanding of divine omnipotence leads inescapably to the conclusion that God does have the power to undo the past. As copiously documented by Courtenay (1972–3: 226n.6/1973: 148 nn.90–1, 149nn.95–8, 157–63nn.124–51), this assertion was made by all of the following: Cardinal Bishop (and Saint) Peter Damian (c.1060), William of Auxerre (c.1075), Bishop Gilbert of Poitiers (c.1130), Rodulphus de Cornaco (c.1343), Archbishop of Canterbury Thomas Bradwardine (c.1344), Augustinian Vicar General Gregory of Rimini (c.1345), and Pierre d'Ailly (c.1375). The writings of these scholars on divinity and preterity were, as a rule, produced before they reached their positions of greatest authority, but it is striking that their claims, even though provoking much vehement opposition (again see Courtenay 1972–3), did not prevent them from later being assigned posts of considerable responsibility. For further discussion of this and related issues in modern philosophizing, see the treatment of earlier work in Gale (1968) – who cites more than a dozen relevant papers, some of them anthologized in Gale (1967) – as well as the dispersed remarks in Turetzky (1998) and the more concentrated ones in Mellor (1998: 34–5, 105–17, 125–35), along with several recent articles and references in Le Poidevin and MacBeath (1993: 225–6) and Le Poidevin (1998).
- 15 We are being deliberately vague here as to the ontological status of the “happening” referred to; what really matters is that, somewhere, there occurred in real time an event which someone wants to describe and to account for scientifically.
- 16 For example, the presentation of grammaticalization in McMahon (1994a) – admittedly an introductory-level textbook, and thus somewhat simplificatory in nature – discusses the development of the Modern Greek future marker (p. 167) solely with reference to Ancient Greek *thélō hina* . . . ‘I want that . . .’ and Modern Greek *tha*, citing not a single stage from among the many attested intermediate forms (for which see chapter 13 below by BRIAN JOSEPH; Joseph 2001a; and Joseph and Pappas 2002).
- 17 In assessing the relative utility, for diachronic linguists, of viewing change as individual innovation versus viewing it as group-wide spread, the experience of researchers in the non-linguistic sciences seems relevant, especially since advocates of the child-oriented, change-as-innovative-acquisition approach so often adduce parallels from evolutionary studies by biologists (e.g., geneticists, ethologists, and certain neurologists). For instance, in just four works (from 1982–99) by one diachronic syntactician writing within the Chomskyan “Principles and Parameters” framework, there can be found references to biology-related research by, among others: W. Bateson, J.-P. Changeux,

C. Darwin, T. Dobzhansky, D. Hubel, F. Jacob, N. Jerne, S. Kauffman, R. Lewontin, J. Monod, J. M. "Smith" (= J. Maynard Smith), R. Sperry, and N. Tinbergen, as well as to Bickerton's (1984) "Language Bioprogram Hypothesis." And, in this volume itself, for example, LIGHTFOOT's chapter (14) likewise cites D. Hubel (and T. Wiesel) and R. Sperry. Still, a salient finding of paleontology – the aspect of evolutionary biology which most closely resembles typical work in historical linguistics – is that, while focusing on individual organisms as the locus of evolutionary change may be a laudable goal theoretically (in both senses of the latter word), such a focus is a hopeless proposition practically, since no serious paleobiologist really expects to find the fossils of the very first creature to evince some innovative trait. Engelmann and Wiley (1977: 3), for example, bluntly state that they "do not know of any paleontologist who would claim to recognize an individual ancestor (as opposed to a populational, species, or supraspecific ancestor) in the fossil record," and so they "dismiss this type of ancestor from further consideration" – whereas the "identification of species and populations as ancestors is a common practice." In consequence, the concrete discourse of most current paleobiologists, when translated into linguistics-compatible terms, turns out to deal with changes less as individual innovations than as either diachronic correspondences or instances of spread. This, at least, is what strongly emerges from a reading of, for example, Dawkins's (1986: 240–1) discussion of

migration as a crucial factor explaining apparently abrupt transitions in fossil records; after all, migration is clearly a contact- and group-related social factor, and so arguably a form of spread. In short, precisely because individual-child-based accounts that view innovative acquisition as the main source for linguistic change so often invoke biology – for example, Lightfoot (1999a) repeatedly mentions, and LIGHTFOOT's chapter 14 here briefly discusses (as we also do in section 1.2.3.4 below), the "punctuated equilibrium" of Eldredge and Gould (1972) and Gould and Eldredge (1993), among others – they must face a paradoxical methodological implication for historical linguistics that emerges from the above-mentioned paleontological findings: namely, explanations in terms of individuals are likely to be revealing only for studies of ongoing contemporary changes, not for the study of large-scale language change(s) in the past – change(s) like Lightfoot's "abrupt . . . [Thomian] catastrophes." On the other hand, the same reasoning suggests a positive reaction to the invocation of population-genetic factors by Lightfoot (1999a) and, within this volume, not just by LIGHTFOOT's chapter (14) but also by JOHANNA NICHOLS's (5).

18 The German scholar Hans Mommsen (1987: 51), writing on Germany in the World War II era (and before), has pointed out that research on history not only involves the filling in of gaps ("on the one hand . . . [,] historiography relies on constant generalization of concrete historical evidence"), but also imposes the necessity

of ignoring a certain amount of (over-)attested data (“[a]ny historical description of the past is . . . a tremendous reduction of the overwhelming variety of singular events . . . [, o]n the other hand”). Similarly, Hockett (1985: 2) discusses the requirement “that historiography must involve abridgment . . . [– t]here has to be deletion” – in light of the fact that an “accurate icon of what has happened in the past would occupy as much space and time as the happenings themselves, and there is no room for it.” This parallels earlier conclusions (acknowledged by Hockett) drawn by Kroeber (1935: 547–8): “[For h]istory . . . to tell ‘what really happened’ . . . obviously . . . is impossible: the ‘real’ retelling would take as long as the happenings . . . and be quite useless for any conceivable purpose. The famous principle is evidently to be understood obversely: history is not to tell what did not happen; that is, it is not fictive art.”

- 19 In this way, historical linguistics is tied to other disciplines that attempt to describe and explain past entities and events. However, linguists may be somewhat better off, in that the insights into language which the present offers (see also subsequent discussion in the main text) often are ultimately better grounded in cognitive and sometimes even neurological aspects of human biology – as opposed to vague appeals to human behavior in general – than are insights that historians might derive from, say, synchronic surveys of how current agrarian societies “work.”
- 20 We intentionally take a broad view here, referring to “documentary”

evidence (and not the more usual “textual” sources) in order to emphasize that sound recordings from a hundred years or so ago can (if playable) help provide evidence of change – for example, Syracuse University possesses a c.1885 Edison wax-cylinder recording of Pope Leo XIII, who was born in 1810) – and the same is true of movies, even silent ones. For instance, some films presenting messages conveyed in American Sign Language were produced by the National Association for the Deaf in the United States in 1913 (fully 14 years before the introduction of sound into motion pictures in 1927, when Al Jolson starred in *The Jazz Singer*), and these still serve as an early record of that language against which later forms can be compared. Indeed, “documentary” evidence of *some* sort is always critical, since, as Hockett (1985: 318) observes: “An initial point of importance about every possible sort of historical evidence is that . . . it must endure. Instantaneous observation is impossible.”

- 21 In our view, this fact casts serious doubt – perhaps even fatally so – on the “Uniform Rate Hypothesis” (URH) that has evolved from Kroch’s 1991 “Constant Rate Effect” (CRE). Admittedly, PINTZUK’s chapter (15) portrays that proposal (the URH) in a quite favorable light, but it is our conviction that the order in which specific changes appear in written language need not reflect the order in which they first appeared in colloquial speech. In particular, we believe that novel patterns which arise individually in spoken language may cumulate for a long period of time before they jointly

achieve a breakthrough, as a set, into writing. If we are right about this, then uniform rate increases across patterns characteristic of written texts may correspond to chronologies for spoken forms which were far from uniform as regards the latter's origin and spread. We therefore find it quite astounding that diachronic syntacticians – both formalists (who focus heavily on the apparent simultaneity of certain developments) and quantitative variationists – so rarely discuss the fact that their crucial and often only data are documents whose religio-juridico-belletristico-commercial nature represents exactly the kind of high-style written language whose reliability as evidence for the vernacular engine driving changes in progress has been consistently called into doubt by sociolinguistics like Labov (1972a) and Kroch (1978). In short, empirical verification of the URH will not be forthcoming until students of syntactic change begin to carry out serious long-term investigations of ongoing developments in contemporary colloquial speech. Still, it remains true that much can be learned from historical-syntactic work based on written texts as long as (i) the documents at issue are simultaneously subjected to careful selection and to evaluative grading (*vis-à-vis* their degree of (in)formality; see, e.g., n. 29 below) and (ii) it is understood in advance that not all apparent “results” actually possess the direct bearing on questions of linguistic change that they superficially seem to have. In short and in general, then, research into the language of any given historical period can only

work with the best evidence at hand, but (to echo the title of a synchronically oriented anthology on Optimality Theory (OT) compiled by Barbosa et al. 1998) we must periodically challenge our conclusions with the query: “Is the best good enough?”

- 22 There is also the possibility of gaining information about change from the comparative method, as discussed below; see also chapter 1, by ROBERT L. RANKIN. The method of internal reconstruction, described by DON RINGE in chapter 3, could likewise be mentioned here, although that method could also be taken to be mainly a matter of applying what we know about change in order to learn something about language history, rather than as a means to gain new information about change *per se*. As a supplement to the much more detailed but somewhat dry overview of “Sources of historical linguistic evidence” in Hodge (1972), see Rauch (1990) for an engaging but still quite detailed account surveying the variety of information about change that can be gleaned from textual interpretation (of various sorts, including the analysis of loanwords) and from considerations of other sorts, including typology and reconstruction. Cable (1990) and Kyes (1990) may also be consulted for general discussion of a similar nature, especially regarding orthography; for discussion of philological methods in the study of Native American languages, see Goddard (1973).
- 23 This is because, in Lightfoot's framework (based on Wasow 1977), indirect passives would involve a non-local application of a

passive rule and thus would have to be derived transformationally. (Here, we use the terminology of the 1970s – i.e., lexical versus transformational passives – even though many more current versions of the intended distinction would no longer refer to “transformations.”)

- 24 The relevant sound changes are the loss of *w and the loss of *s – intervocally as well as, later, initially. The meaning for *éor* given by Hesychius is not only ‘daughter; relative; kinfolk,’ but also “(male) cousin,” so we must clearly reckon with a semantic shift, too – not surprisingly, perhaps, since Greek innovated a new word for ‘sister’ (*adelphē*, from *sm-g^welbh-, literally ‘having the same womb’).
- 25 There is another side to the accidental aspect of attestation. Since the availability of documentary information largely determines the accuracy of any account of the past, any skewing of available knowledge has the potential to have a significant impact on how the past is interpreted. Thus, Weinberg (1988), observing that the paper upon which documents were written by most officials during World War II was of exceptionally poor quality and thus will not survive as long as will, say, the papyri or cuneiform tablets of the ancient Eastern Mediterranean and Middle East, notes further that only one World War II German official, the “Bevollmächtigter des Reichführers-SS für das gesamte Diensthunde- und -Taubenwesen” (i.e., the “Plenipotentiary of the National Leader of the SS for All Military Dog and Pigeon Affairs”), was “equipped with an exemplary

stock of paper.” He then comments wryly that “it will be interesting to read histories of World War II based on the surviving records of that agency.” Such histories based on selective – and accidental – survival are not just a figment of Weinberg’s imagination, since one can cite works such as Chadwick (1976), in which one of the decipherers of the Mycenaean Greek Linear B tablets deliberately set out, in a very interesting and enlightening study, to “present a picture of Mycenaean Greece as it can now be reconstructed from the documentary evidence” of the tablets alone (p. x), rather than relying on (supporting) archeological evidence. What we see of Mycenaean life in such a (perhaps artificially restricted) study is thus selectively, and accidentally, restricted to what can be gleaned from the records of activity in the Mycenaean palaces in the few weeks before their destruction at the end of the thirteenth century BC. Similarly, as Bailyn (1986: 9) points out, “the most extensive run of detailed information about any large group of immigrants [to America] in the colonial period was produced just before the Revolution by the British government, responding to fears that the mass exodus to America then under way would depopulate the realm”; this skewing of information about who settled in British North America has been a boon to linguists, for it has enabled research into the bases of varieties of American English, and into the important role played by Irish and Scots settlers, that would be impossibly speculative otherwise (see, e.g., Rickford 1986 and Winford 1997 on the influence of

these settler dialects in the formation of African American Vernacular English). See also n. 28 below.

- 26 For example, Spanish *mierda* and French *merde* are both used in this way, and they continue a different lexical proto-form from their Modern English counterpart.
- 27 Anyone tempted to turn up his or her nose at the subject matter of this paragraph should see n. 31 below.
- 28 The degree to which surviving documents – especially printed ones – create an illusion of at least locally unchanging permanence in language is quite striking. To take a concrete example, we have open before us at this writing, as one outcome of the vagaries of book preservation (and collecting), a 1775 German work printed in Quedlinburg, Saxony-Anhalt (then part of Brandenburg-Prussia): *Des Claudius Aelianus vermischte Erzählungen* (in English, “*Aelian’s (Historical) Miscellany*’”; in Latin, “*Varia historia*’”), translated (and annotated) by one J. H. F. Meineke from the Greek original (*Poikilē historia*) written by a Roman author who flourished in the third century AD. The covers of this book are somewhat the worse for wear, but the 600-plus pages between them are better preserved than those of most volumes printed in, say, 1875, and the text of the language thereon has, to all intents and purposes, now remained unchanged – in a documentary sense – for well over two centuries. If this collection of “morally improving” human stories and unrelated animal facts were the only available document from the East Middle German area for, say, fifty years on either side of the

date in the translator/annotator’s foreword, we would have little sense of the linguistic ferment characteristic of German during this era. The relevant paradox, then, is that such long-surviving linguistic artifacts can misleadingly tempt us to underestimate the speed and extent of language change, but we at least have access to them, whereas non-surviving documents (when we know of their existence, as we often do) connotatively suggest a more realistic picture of variation and change, but we cannot consult them. (Readers can test this assertion by asking their historical-linguist colleagues, “Which language had more dialectal diversity, Old High German or Gothic?”; we wager that the most common answer – or at least initial response – will pick Old High German, due to the relatively wide temporal and geographic variety of OHG’s written attestations versus the extreme concentration of written Gothic in Wulfila’s Bible translation – despite the much greater geographical dispersal of various Gothic-speaking groups: for example, from Crimea to Iberia just along the east/west axis.) For a twentieth-century historian’s masterful discussion of electronic-age parallels to such problems of documentary preservation and their consequences for later historiography, see Weinberg (1988: 329–31, 335–6). And, for a specifically linguistic perspective on this and related matters, see Hockett’s (1985: 32) discussion of such issues as the fact that “an inscription or manuscript may last for centuries or millennia before it has crumbled or faded beyond legibility.”

- 29 Historical linguists sometimes are in the fortunate position of having access to earlier texts which are deliberately crafted so as to approximate colloquial usage or the like, such as plays or other works of fiction containing vivid dialogue. Still, since these works are constructed and so may contain stereotyped linguistic features or atypical frequencies (even if these exaggerations have some basis in reality), they must be used judiciously; they certainly cannot be uncritically taken at face value. (A relevant cautionary note along these lines is already sounded by Labov's (1972a) demonstration that the speech of "lames" – marginal members of American inner-city social groups – seems authentic to outsiders but can be shown by variationist techniques to be quantitatively deviant from the speech of core group-members.) For an intriguing study utilizing dialogue from Portuguese poems and plays of the fifteenth and sixteenth centuries in order to support a particular position on the origins of pidginization, see Naro (1978).
- 30 The most vivid and eloquent characterization of the relation between colloquial speech and written varieties of language is – in our opinion – that of Vendryès (1925: 275–6, trans. Paul Radin): "The . . . creation of written language[s] may be compared to the formation of a film of ice on the surface of a river. The ice borrows its substance from the river . . . [;] it is indeed the actual water of the river itself – and yet it is not the river. A child, seeing the ice, thinks that the river exists no more, that its course has been arrested. But this is only an illusion. Under the layer of ice . . . [;] the river continues to flow down to the plain. Should the ice break, one sees the water suddenly bubble up as it goes gushing and murmuring on its way. This is an image of the stream of language. The written tongue is the film of ice upon its waters; the stream which still flows under the ice that imprisons it is the popular and natural language; the cold which produces the ice and would fain restrain the flood . . . is the stabilizing action exerted by grammarians and pedagogues . . . [A]nd the sunbeam which gives language its liberty is the indomitable force of life, triumphing over . . . [prescriptive] rules and breaking the fetters of tradition." We note though that for many speakers of a "dialect" (or linguists describing one), the sociolinguistic reality typically involves measuring their usage against that of the standard, often leading to a diachronically inaccurate, but synchronically no less real, mapping between the standard and their dialect, with dialect rules and generalizations derivable from those of the standard language (via what Andersen 1973 has called "adaptive rules").
- 31 The ennobling of coprolites via their use for modern scientific purposes surely reached its acme in the literally celestial heights aimed at by Buckland (1836: 154), whose treatise "on the power, wisdom and goodness of God . . . as manifest in the creation" included a long section on the evidence for masterly design found in the structure of ichthyosaurus intestines – which, though reconstructible only from fossil feces, fully demonstrate the

- extent of divine care and attention to detail inferable from “the beneficial arrangements and compensations . . . even in those perishable . . . yet important parts” (cf. Gould 1987: 99–100). On the subject of the archeological (and paleontological) value of coprolites more generally, cf. Renfrew and Bahn (2000: 12, 240, 244, 255, 269, 296, 306, 379–380, 424, 442, 477, 481–2, 501–2, 566).
- 32 Cf. the similar comments of an anthropologically well-versed linguist – Hockett (1985: 323): “archaeologists['] . . . evidence is . . . especially those rich concentrations of human byproducts in the cesspools . . . , garbage dumps, slag heaps, trash piles, and abandoned buildings of the world.” The (non-linguistic) anthropologist Salwen (1973) has extended this trend to its logical conclusion by, for example, making his students of urban archeology aware of the parallels that exist between “the defacement of statues of gods and kings . . . follow[ing] . . . the conquest of one ancient state by another . . . and . . . [the] examples of vandalism [which] are a frequently visible part of the urban setting.” Much as Rathje does, Salwen poses the question (p. 154) of whether “it might be argued that a site becomes the proper domain of the anthropological archeologist as soon as . . . [a] behavior stops and . . . the actors leave the scene!” (cf., as well, the “industrial archaeology” discussed in Hudson 1971: 1, who focuses on “material relating to yesterday’s manufacturing and transport which has survived, more or less intact, on its original site”). This orientation is strongly parallel to one recommendation made here
- in section 3 below: that students of language change spend a substantial fraction of their time investigating ongoing linguistic developments occurring in the present.
- 33 The Vulgar Latin characteristics exemplified by Pompeiian graffiti and by the *Appendix Probi* presumably both reflect primarily urban speech-forms close to those found in Rome itself, while the Vulgar Latin traits found in the wood strips excavated near the Vindolanda fort in Britain are likely to include a greater number of rural forms. Still, Joseph and Wallace (1992: 105) have established connections between these two sorts of non-Classical Latin by presenting evidence that a “transformation of originally geographic variation into socially determined variation in an urban setting resulted from migrations into Rome and the expansion of Rome after the fourth century BC.”
- 34 See Janda (1995) for a discussion of related problems which make it difficult not only to arrive at but also to organize and present a history of earlier English in a manner that does justice to those continuities between Old English and Middle English which can be established. Recall also the related dictum made famous by the British historian Lord Acton: “Study problems in preference to periods” (often quoted as “Study problems, not periods!”); see Dalberg-Acton (1895, quoted from 1930: 24).
- 35 Nonetheless, despite this lack of direct continuity in our records of English, it is common for linguists to make comparisons across the different periods of the language as if they were truly meaningful; this is a graphic instance of

Labov's characterization of historical linguistics cited above in section 1.2.1, since in doing so, one is simply making the most of the imperfect situation that the accidents of the attestation of English have provided, and letting an indirect ancestor stand in for the unattested direct ancestor. Although dialects can differ radically from one another, this step is based on the reasonable assumption that a given non-ancestral dialect is likely to be linguistically closer to the unattested ancestor than any other available point of comparison.

- 36 The "present" is a moving target, of course, since time continually – and continuously – keeps pace with change (which, it has been said, is the only constant; cf. Swift 1964: 251: "There is nothing in this World constant, but Inconstancy"). There is always a "present moment," yet, in virtually no time at all, one current instant yields to another (in a way often described as "slipping into the past"). Still, by "present," we here mean all moments within recent memory that remain potentially salient for speakers, or some reasoned extension of such a notion. Such an extended present may seem parallel, on a greatly enlarged scale, to the "specious present" (cf. Clay 1882: 167), also known (at least since Calebresi 1930) as the "psychological present" – a notion which has been adopted or discussed by psychologists and philosophers like James (1886: 374–9/1890/1918: 605–10); cf., for example, Mabbott (1951), Whitrow (1961: 71–7), Turetzky (1998: 125, 158), and their references. However, as Mellor (1998: 9) points out: "[I]f . . . [t]he present . . .

[were] confine[d] to the present moment . . . [t]hen many events . . . which last some time . . . would never be present. This problem has prompted the doctrine of the so-called 'specious present', which lets the present encroach a little on the past and the future. But by how much – a minute, a nanosecond? . . . [Here,] what is specious is the idea of a specious present, not the present itself." Therefore, Mellor (1998: 9) continues: "[t]he right way to define the present is this . . . [i]n 1943, World War II stretched four years into the past and two years into the future. Yet it was certainly present then, as any combatant would then have testified. So its . . . time, a six-year . . . interval including the present moment, should, despite its length, count as present. Similarly, we should call any . . . time 'present', however long it is, if and only if it includes the present moment. That makes *this century* as present [a] . . . time as *today* or *this moment*. And so it should, since a centenarian whose . . . time it is will obviously be present throughout it." Thus, as long as we respect some such lifetime-length limit, we can argue that, for example, the 1950s are still "present" for many of us, even though they are over forty years removed from the time of this writing. It is this extended sense of "present" which allows us to discuss synchronic "slices" of a language that are broader than an instant, and which makes it meaningful to treat, say, "late-twentieth-century American English" or the like as a present (but *not*, for example, a 400-year period like "Middle English," often dated c.1100–1500). Perhaps the most revealing approach to the

extension (i.e., extendedness) of the present moment was provided by Roman Jakobson (cf. Jakobson and Pomorska (Jakobson) 1988: 484): “[S]ynchrony[’s being] . . . equated by Saussure . . . [,] both terminologically and theoretically . . . [, with] a static state . . . [can be] criticiz[ed by] . . . referr[ing] . . . to . . . cinematographic perception. If a spectator is asked a question of synchronic order (for example, ‘What do you see at this instant on the movie screen?’), he will inevitably give a synchronic answer, but not a static one, for at that instant he sees horses running . . . [or] a clown turning somersaults.”

37 At the very least, Ancient Greek dialects – such as East Ionic – which are “psilotic” (i.e., have lost Proto-Greek word-initial *h*-) constitute a counterexample to this claim, as Hock (1993b) has followed Allen (1976) in pointing out. Still, for the sake of argument, we nevertheless assume here that this claim could possibly be correct. A further part of Jakobson’s claim here, namely that the presence of voiced aspirated consonants in a language implied the existence of voiceless aspirates, has been used by Gamkrelidze and Ivanov (1972, 1973, 1984 and elsewhere) and Hopper (1973) as an argument for their “glottalic” reinterpretation of the traditional reconstruction of the Proto-Indo-European obstruent system (touched on again in section 2.1). The fact that Jakobson was wrong about the one claim concerning aspiration makes us skeptical about basing too much on others of his putative universals. See Salmons (1993) for a useful summary of the “glottalic theory,” and Hock (1993b) for an overview

of various counter-arguments; see also Dunkel (1981), Garrett (1991), Job (1995), and Joseph and Wallace (1994) for some critiques of this “theory” and of the methodology.

38 The stage with [f θ x] but not [h] is in fact characteristic of what Ionic Greek ultimately developed into: namely, (standard) Modern Greek.

39 Indeed, given the existence of Ionic Greek (see n. 38 above), it is likely that this generalization is not an iron-clad one; instead, it may reflect a tendency rather than an absolute constraint on possible systems. Also, given what is known about the chronology of the change $h \rightarrow \emptyset$ vis-à-vis the fricativization of earlier voiceless aspirates in Greek, it seems clear that the loss of [h] occurred first. Hence, in the real-world analogue of the hypothetical case described here (in the main text), an earlier Greek system with both [p^h t^h k^h] and [h] passed first to a stage with [p^h t^h k^h] but not [h], and only then to a system with the relevant voiceless fricatives. The fact that Ionic Greek is not currently “in the present” is irrelevant; after all, it is a well-documented, attested language state, and thus in a sense it survives into the present via this documentation – and in any case, it existed at *some* “present.”

40 Positing the putatively forbidden stage as a way-station – a transitory state that existed only briefly, between two “well-behaved” (i.e., typologically satisfactory) states – is extremely problematic. This is because, even if short lived, such a state would nonetheless constitute – for the entire duration of its existence, however evanescent – a possible human language. Presumably, therefore, nothing would require

the alteration of this stage (absent a substantive theory of markedness which would be able to demonstrate conclusively that certain elements or structures are measurably more difficult to acquire, retain, or use), and so the putative universal in question would have to be downgraded to a non-absolute constraint. Speakers living through a stage in “violation” of such a putative universal could not be expected to know – again, unless there existed some substantively worked-out notions of markedness (whether innate or acquired) – that they have to change their language state in order to conform to the universal at issue; for them, that state is simply what their language is! For further discussion of the problems besetting such “trigger/chain[reaction]” theories, see Hawkins (1983) and earlier references there.

- 41 For further discussion of William of Ockham (or Occam) and his – or his predecessors’ (as well as his successors’) – relation to the razor-like principle of parsimony, see especially Boehner (1957: xx–xi), Adams (1987: 156–61), Beckmann (1990), and Maurer (1999), plus the bibliography in Beckmann (1992: 162) and the broad overview in Spade (1999). There somehow is something very fascinating, very winning, about this multifaceted figure from the late Middle Ages, who, though still a person of his time, penned volumes of writings ranging as far as the subject of politics (political science, one might even say) and encountered considerable risks and hardships due to the resoluteness of his own religious, philosophical, and political beliefs (e.g., he condemned the doctrine of papal supremacy

over secular authorities outside of religious matters). In semiotician Umberto Eco’s best-selling (1983) novel *The Name of the Rose* (*Il nome della rosa*, set in 1327), the fictional character called “William of Baskerville” (“Guglielmo da Baskerville”) – likewise an English-born monk – arguably owes much not only to the fictional detective-hero of Sir Arthur Conan Doyle’s (1902) *Hound of the Baskervilles* (i.e., to Sherlock Holmes) but also to the real William of Ockham. On the other hand, Baskerville sometimes mentions Ockham as one of his mentors and so must clearly be distinct from him; cf., for example, Haft *et al.* (1987) and the papers in Inge (1988). We mention fictional detectives here because, as Haft *et al.* (1987: 21) remind us, “historians . . . are Academe’s quintessential sleuths,” and historical linguists surely are no exception to this generalization.

- 42 For book-length studies on the new catastrophism, see the anthology by Berggren and Van Couvering (1984), as well as the following single-authored works: Albritton (1989), Huggett (1989), and Ager (1993), plus references there.
- 43 We have in mind here especially the French historical semanticist and general diachronician Bréal (1866: xxxviii–xxxix/1991a: 38–9) and the Danish classicist Madvig (1842: 56).
- 44 Drawing on suggestions made mainly in publications by Carozzi (1964), Mayr (1976: 343), Rudwick (1972), Burkhardt (1977), and von Rahden (1992), we provide below a list of European scholars who either advocated uniformitarian ideas or put them into practice before (sometimes long before) Whewell coined the term

uniformitarian(ism) and basically credited Lyell with the corresponding concept. Instead of – (mostly) parenthesized – dates of publication, all of the years in this list are bracketed and indicate known or approximate lifespans. Among those deserving of honor as uniformitarians *avant la lettre* are, in chronological order according to birth year (and also in alphabetical order, in cases of shared birth years): Galileo Galilei [1564–1642], Marin Mersenne [1588–1648], René Descartes [1596–1650], John Wilkins [1614–72], Nicolaus Steno [1638–86], John Locke [1632–1704], Isaac Newton [1642–1727], Gottfried Wilhelm von Leibniz [1646–1716], Bernard Le Bovier, sieur de Fontenelle [1657–1757], César Chesneau Du Marsais [1676?–1756], Pierre(-)Louis Moreau de Maupertuis [1698–1759], Georges Louis Leclerc, comte de Buffon [1707–88], David Hume [1711–76], Jean Jacques Rousseau [1712–78], Étienne Bonnot de Mably, abbé de Condillac [1715–80], Georg Christian Füchsel [1722–73], Nicolas Desmarest [1725–1815], Anne-Robert-Jacques Turgot [1727–81], Horace-Bénédict de Saussure [1740–99], Peter Simon Pallas [1741–1811], Jean-Baptiste Lamarck [1744–1829], Jean-Guillaume Bruguière (1750–98), Déodat de Dolomieu [1750–1801], Alexandre Brongniart [1770–1847], Georges, Baron Cuvier [1769–1832], Karl von Hoff [1771–1837], George Poulett Scrope [1797–1876], and Heinrich Georg Bronn [1800–62].

- 45 Besides the authors mentioned in the main text, the following scholars had called attention to the non-monolithic (polyolithic?) nature of Lyell's uniformitarianism before the 1980s (and the appearance of

Christy 1983): Krynine (1956), Cannon (1960, 1961), Kitts (1963), Albritton (1967b), Goodman (1967), Hubbert (1967), Newell (1967), Wilson (1967) – the last five collected in Albritton (1967a) – Davies (1969), Hooykaas (1970b), Simpson (1970), Mayr (1972, 1976: 243, 248, 284–8), Rudwick (1972), Wilson (1972), Bartholomew (1973), Bowler (1976), and Ospovat (1977). As for during and after the 1980s, the corresponding list of scholars should include the following: Mayr (1982: 375–81, 875), Laudan (1987), and Le Grand (1988), among numerous others.

- 46 A directly related issue concerns the fact that, for times in the recent past, periods that are temporally closer to the present do not necessarily have more information available from (and about) them. Recall, for example, n. 25, where we cited the suspicions of Weinberg (1988) that, given the extremely poor quality of most paper used during World War II, it could happen that the greater survivability of the small, somewhat randomly distributed supplies of high-quality paper used during that conflict might give a skewed picture of major international events (e.g., if they reflected only the perspective of officials who managed the use of dogs and pigeons for military purposes).
- 47 An idea of the debates now actively raging about the nature of family life in earlier times can be gained by consulting the following: Shorter (1975), Stone (1977), Trumbach (1998, among other works), and Ozment (2001, among other works). Though reptilian monsters clearly have not always

had a major appeal for youngsters, modern-day children often display a strong interest in dinosaurs – whereby the amount of information now known about these creatures reflects increasing application of uniformitarian principles in paleontology. Thus, for example, research on dinosaurs has been little short of revolutionized by the incorporation of insights gained from the study of living creatures – as regards, for instance, their anatomy and physiology, as well as their behavior in mating, nesting, herd-travel, etc. For passionate advocacy of such reptilian uniformitarianism addressed to a general audience, cf. Bakker (1975, 1986), as well as Horner and Gorman (1988).

48 McLeish (1996: 14), for example, excoriates the strong non-uniformitarian trend in nineteenth- and twentieth-century classics education. He writes: “European universities became filled with magnificently reconstructed texts which . . . no one bothered to relate to the living beings who had created and enjoyed them in the first place. This miserable tradition persisted well into our own time. In the 1950s, some schoolmasters were still telling their pupils not to visit Athens in case its untidy charms spoiled appreciation of the true ‘glory that was Greece’. . . . That there was life beyond the dative absolute, that the relevance of the ancient world was not a matter of texts and lists but involved the common human elements they contained, the flesh, blood, tears, lust, ambition, joy, despair, sweat, sperm – this was something that few self-respecting [Oxbridge] dominies ever thought to share with impressionable

adolescents.” For a discussion which threads its way skillfully around presentism, past antiquarianism, through immediatism, and near some of the many and varied other *-isms* which cluster around uniformitarianism (although the author in question does not actually use the latter term), see the short quotation from US historian Fischer (1989: ix) in n. 143.

49 It has been known for quite some time that, at the very least, Russell’s (1903) definition of change has two rather problematic – or at least counterintuitive – consequences, one of which was recognized by Russell himself. The less serious of these (cf., e.g., Charlton 1995: 129) involves the fact that, while a transition from something to (virtually) nothing does indeed seem to constitute a change (e.g., an explosion that vaporizes a table clearly changes the table), a transition from (virtually) nothing to something does not obviously seem to change the latter entity (e.g., a carpenter who builds a table is not usually said to have changed the table). Yet both cases involve a situation where “A table exists” is true at one time but not at another time. More serious (cf. Crane 1995: 115, ultimately following Geach 1969: 91, 99) are instances where Russell’s definition implies that one entity has changed solely because its relation to another object has been reversed by an alteration physically affecting only that other object. Thus, if “Our mothers are taller than we are” once held true at some time but now no longer holds true (because we have grown taller than our mothers), it counterintuitively follows from Russell’s definition that our

- mothers have changed and that this is entirely due to growth on our part. Given such unusual characteristics of the definition for change which Russell published during his early years as a fellow of Cambridge University, Geach (1969: 71, 1979: 90–2) later initiated the still-current practice (cf., e.g., Strobach 1998: 132 et passim) of distinguishing between the “Cambridge (Conception of) change” – also known as “C-changes” – and genuine change; cf. also Cleland’s (1990) paper “The difference between real change and *mere* Cambridge change.”
- 50 On the impossible but endearing figure of McTaggart – who achieved something close to notoriety as a nihilist among philosophers for his above-mentioned denial that time exists, and who was known to be a convinced atheist – cf. Geach (1979: 6 et passim), who quotes from Dickinson (1931) this 1st-person statement by McTaggart: “The longer I live, the more I am convinced of the reality of three things – truth, love, and immortality.”
- 51 Cf. Carlson (1977), whose distinction between “individual” and “stage-level” predicates obviously intersects with – but arguably is not identical to – the distinction discussed in the main text.
- 52 Here we implicitly echo Hoeningwald’s remark (1960: 3n.5) that “any historical statement contains, avowedly or otherwise, at least two synchronic statements – one for each of two or more stages.”
- 53 A striking parallel to Bynon’s (1977) and Bloomfield’s (1933) implied claim that the present has insufficient temporal length to permit insightful research on linguistic change can be found in Plog’s (1973: 181–3) discussion of archeology as “diachronic anthropology” (“the study of temporal variability in human behavior and the products of that behavior”), as distinguished from “synchronic anthropology” (“the study of spatial variability in human behavior and its products”). Plog first asks: “If a scholar is interested in behavior and cultural processes, why would he [or she] not choose to work with these topics using the far richer sociocultural record of the present . . . [,] rather than the limited and elusive record of the prehistoric past?” He next mentions two possible reasons for preferring the study of non-contemporary culture and artifacts – because of “an intrinsic interest in the past,” or because “there may be sociocultural phenomena . . . in the record of the past that do not occur in the modern record” – but then downplays these in favor of a third “justification for a science of past sociocultural phenomena,” one that “focuses on change in time.” Namely, argues Plog: “By and large, it is difficult and even impossible to study sociocultural change using modern data. Adequate event records that describe sequences of change cover longer periods of time than most ethnographers spend in the field . . . [,] periods . . . sometimes longer than the lifetime of a scholar. But such event records or sequences are the everyday concern of the archeologist.” However, this conclusion totally overlooks the crucial difference between *diachronic correspondences*

- and *changes* (and *innovations*) discussed here above in section 1.2.1: in terms of this distinction, it is archeologists who are usually in an inferior position when it comes to describing and explaining change(s). And, in any case, there is no law which prevents scholars – in anthropology or linguistics – from organizing studies of ongoing change in such a way that their window of data-gathering and analysis spans more than one lifetime (for further discussion of this and related issues, see section 3 below).
- 54 The spatial-orientation metaphor here derives from the standard “tree”-like schematization employed for showing language relationships.
- 55 That is, a critical part of the comparison process involves the interpretation of texts, whether or not these consist of direct testimony (such as inscriptions, manuscripts, personal letters, public documents, etc.) or indirect testimony (such as comments by travelers or grammarians about some first or second language). See n. 22 for references regarding philological methodology.
- 56 See n. 20 above.
- 57 More accurately, we should here say “between related speech-forms,” since the comparison in question could be one across dialects or could even involve a comparison of variable realizations for some feature across (but firmly within) a given speech-community.
- 58 That is, if related language A and related language B disagree in some comparable feature, then either their immediate common ancestor proto-language was like A, so that B is innovative, or it was like B, so that A is innovative, or else it was like neither, so that both must have innovated.
- 59 And recall the problem with establishing lineal continuity in English (or any language, for that matter) discussed in section 1.2.1.6.
- 60 This formulation represents an unusually eclectic blend of approaches to grammar, reflecting (or at least intending to reflect) the work not only of Chomsky and other generativists, as well as of Labov and other variationists (who come more to the fore in the following main-text paragraph), but also of Coseriu (whose views have influenced many semiotically inclined linguists). For further discussion of norm, speech, system, and the additional notion of type, see Coseriu (1952, 1958, 1968, 1982).
- 61 Hoenigswald (1960: 2), for example, observes that “disappearing discourses may be *replaced*, in what must be called the ‘same’ life-situation, by new discourses . . . [; t]he study of the effects of loss, emergence, and, more properly, replacement of discourses . . . [–] that is, the study of linguistic *change* . . . [–] is the subject matter of *historical* (*diachronic*) linguistics.”
- 62 And certainly earlier than its first documented occurrence in writing; see section 1.2.1 (and n. 21) for some relevant discussion.
- 63 And, for many proponents of grammaticalization (see, e.g., HEINE’s chapter 18), change possesses a distinct directionality, which, it is claimed, is obvious and recoverable, at least for linguists. Even though, as documented by Janda (2001), they tend not to dwell on the role of speakers in change, advocates of grammaticalization presumably thus tend to see directionality as something which

speakers, too, could be aware of, and from which they could then gain a sense of historical perspective on their language that is wholly derived from synchronic evidence available to them. However, ordinary speakers do not always do what linguists appear to believe they ought to do (see Joseph 1992 for some discussion of “opaque reanalyses”), so there is no reason in principle why speakers would infer historically correct directionality from synchronic evidence. Moreover, there in fact exist numerous cases of “counter-directionality” in the literature (see Janda 2001 for a list and discussion); that is, changes that run counter to the directions claimed by grammaticalization theorists to be natural or uniquely attested. The problem, as we see it, comes from linguists necessarily adopting a perspective on a language (e.g., through access to information about earlier stages, about related dialects and related languages, etc.) that is different from the perspective that any normal native speaker of that language, especially a preliterate speaker, could possibly take. The actual historical directionality for a change need not matter to speakers, as long as they can construct *some* mechanism to account for a particular alternation or relationship within their language. See, for example, Anttila (1972) on a speaker’s synchronic relating of non-cognate tokens of *ear* (of corn and on the head).

64 Montelius studied the axes, clasps, knives, and swords of the Iron Age, and also extended some of his conclusions based on Scandinavian findings to other parts of Europe, but “the grand old man of Swedish

archeology” is best known for his chronology of the Nordic Bronze Age, c.1800–500 BC, which – based on a typology of bronze objects – he partitioned into subdivisions still referred to as “Montelius Periods I–III” (Early Bronze Age) and “Montelius Periods IV–VI” (Late Bronze Age); cf. Sørensen (1996: 623). The particular typological method used by this “Linnaeus of archeology” involved establishing sequences of artifacts ordered according to the assumption that, to the extent that two objects are near to each other in shape, they must also have been near to each other in time. Despite his strong evolutionary bias, though, Montelius was interested in diffusion, too, arguing that the institutions and technologies of European society had originally come from Asia – a view dubbed the *ex oriente lux* (“light from the East”) brand of Near Eastern diffusionism; cf. Klejn (1996: 286–7), McIntosh (1996: 283). On both the life and the work of Montelius, see the papers in Åström (1995); for a critical but fair assessment of Montelius’s typological method (which seems to have been slightly anticipated by his colleague Hans Hildebrand), see Gräslund (1987: 56–120); on the general history of Scandinavian archeology, cf. Klindt-Jensen (1975).

65 Gräslund (1987: 5–12, 86–90) shows that Montelius avoided some of these ambiguities by using two strategies in tandem: (i) his “typological” method (focused on the serial development of one type of object across many find-sites), and (ii) the “find-combination method” (focused on the totality of objects found at each site). The kind of problem thereby avoided is

familiar to linguists. For example, when told that someone has found three texts with the respective schematic characteristics (i) ABC, (ii) AEI, and (iii) GHI, we cannot be sure whether these texts reflect a diachronic sequence (i) ABC > (ii) AEI > (iii) GHI (among other options) or a synchronic simultaneity that arose because these texts come from three adjacent languages which had the characteristics (i) ABC, (ii) DEF, and (iii) GHI until, via borrowing, language (ii) replaced its D with (i)'s A, and its F with (iii)'s I, yielding AEI. Such two-edged borrowing by a geographically intermediate group can happen in language or in material culture, and so cause not only linguistic but also archeological ambiguities – at least when a researcher uses only the “typology” of Montelius, as he himself sometimes seems to suggest that he did. Altenderfer (1996: 727), though, says in Montelius’ defense that, before “the advent of absolute dating techniques, . . . typological analysis, . . . with stratigraphic excavation, was the only means by which archaeologists could develop cultural-historical sequences or otherwise measure the passage of time”: that is, through “the systematic arrangement of material culture into types based on similarities of form, construction, decoration . . . [.] style, content, use, or some combination of these.”

- 66 The only problem with using Montelius’ (1899) developmental sequence of mid-nineteenth-century train-cars – also variously known as *railroad/railway car(riage)s* – to illuminate the parallel discontinuity of language transmission among humans is that the train-cars in

question were the manufacturing products of three different countries: Britain, Austria, and Germany (for the Swedes). As such, they do not appear, at first glance, to represent a single line of development. Rather, these conveyances might collectively seem analogous to the situation of Old English (OE) versus Middle English (ME) discussed above in section 1.2.1.6 – that is, that the (documentarily) predominant dialect of Late OE is poorly attested in Early ME, and vice versa – which might support a claim that the discontinuity at issue is found not within one entity but across multiple entities. For our present purposes, however, this is a difficulty of practice, rather than principle. First, we assume that Montelius (1899) used train-cars from three different countries because a chronologically equivalent sequence of readily comparable drawings with train-cars from one country was not available to him (this is largely the basis for our own choice, at any rate). We therefore commit to securing a return ticket and coming back with a unified (i.e., intranational) set of drawings in the future – and we wager that these will exhibit the same characteristics. For instance, we have already found, pictured in von Röll et al. (1917: 17), a British train-car from 1838 that is virtually identical to Montelius’ 1840 Austrian one; it is also probable that the German-made Swedish train-cars from c.1857 were based on British models (cf. von Röll et al. 1917: 18). Second, since the British train-car of 1825 was directly copied by most European railway systems, including that of Austria

before 1840, and since there were contacts between German and Austrian train-car builders between then and the 1850s, an alternative case can be made that Montelius's sequence of train-cars does represent a single line of development (i.e., what we called "direct lineal descent" in section 1.2.3.8).

67 To prove that such transportation-based examples can literally get off the ground, we can cite identical developments among more modern conveyances, like jet airplanes: for example, the more recently introduced Boeing 767 jets have not yet crowded all the older-model Boeing 747s from the skies, though someday they may, just as the much earlier Boeing 707s and other jets eventually replaced most (but not all) propeller-driven airplanes from the business of transporting large numbers of passengers over long distances. Yet even supersonic air-travel in the twenty-first century, just like Montelius's (1899) sequence of mid-nineteenth-century trains, involves a remarkable carry-over from the latter's precursors – stagecoaches: English-speakers still commonly talk about "flying coach (class)" ("traveling by air while seated in a plane's economy-fare section").

68 Essentially this conclusion was expressed (much more memorably) by Collingwood (1946, here quoted from 1993: 482–3): "The whole of the present consists of traces or residues of the past, for the present is that into which the past has turned, and the past was that which has turned into the present. To speak, therefore, of the traces of the past in the present is to speak of the present and nothing but the present." Such argumentation is similar to that used by Thomason

(1980: 419) in a book-review passage that ends by likewise addressing issues of language change: "If . . . [it] is correct . . . [to] repeat . . . that "'everything' in language is analogical' . . . , then . . . [it] is also correct – trivially – . . . [to] say . . . that analogy explains everything in language. But then it is equally correct to say that analogy explains nothing . . . [,] and we must re-invent traditional analogy, under other names, . . . to provide explanations for specific linguistic changes or types of changes."

69 The view of change and/or non-change that emerges here provides some insight into a matter of some concern to historical linguistics, namely whether a language such as Vulgar Latin (as attested in the Pompeian graffiti, for instance – see section 1.2.1.5) is a dead language or not. On the one hand, one could argue that it is still alive, being continued, albeit in an altered form, in the various Romance languages of today. On the other hand, one could argue that that precise form as recorded in Pompeii and reflecting colloquial usage of the first century AD is no longer with us and thus is extinct. Biology again provides a useful concept and term that are applicable to such cases: Scott (1996: 457), in defining the term *extinction* as "the discontinuation of the existence of an animal or plant species or taxon," notes that "many animals and plants . . . do not become extinct in the true sense; they undergo *pseudo-E[xtinction]*, i.e. they disappear from the fossil record by evolving into something else (the genome is not lost but altered)." Thus, Latin could be said to be "pseudo-extinct," whereas

a language such as Hittite or any of the once hundreds of native languages of the Americas, which were not continued in any form since their speakers shifted to another language entirely or else died out without linguistic issue, would be truly extinct (dead) languages.

- 70 Colloquially, a *clone* is 'a virtually identical copy,' and so *cloning* can refer to the direct copying of a complete, full-sized (e.g., mature-adult) version of some entity. But a *clone* in the technical sense was originally – in the term's first English use, in 1903 – "the aggregate of the asexually reproduced progeny of an individual," later also "a group of replicas of (all or part of) a macromolecule (like DNA or an antibody)," and now most often "a genetically identical offspring grown from a single somatic cell of its parent." But one kind of cloning has existed for thousands of years: the cuttings used to create genetically identical copies of plants (note that English *clone* is based on Greek *klōn* 'slip, twig'); it is only so-called "higher organisms," especially mammals, that are difficult to clone. For the latter, cloning requires considerably more complicated steps, as shown by the 1997 cloning of the lamb "Dolly" by Ian Wilmut's team (after 277 unsuccessful tries!), discussed in Kaku (1997: 225–7, 379). Still, the "virtually identical copying" sense of cloning is now essentially an additional technical meaning of the term, because at least one biologist has extended cloning-related terms like *replicate* from genetics to cognitive domains. That is, the *replicators* first proposed by Dawkins (1976: 15–20,

191–3, 254, 269–74, 322–3, 1978, 1982a; cf. also Hull 1980, 1981) and since characterized (Dawkins 1982: 83) as "any entit[ies] . . . of which copies are made," including (Dawkins 1986: 128) "self-copying entities," have always included *memes* (from *mim(e)-eme-s*): units of information (ideas, styles, etc.) that reside in structures like brains, books, or computers. It is thus not surprising that several historical linguists have avidly promoted replication as a useful conceptual tool for dealing with language change (and especially with individual innovations, though this distinction is not always made): see, *inter alios*, particularly Ritt (1995), but also Janda (1994a, 2001: §5), Lass (1997: 111–13, 378–81), Johanson (2001) (who here, and elsewhere, characterizes borrowing as "copying"), and, with different terminology, Lightfoot (1999a: passim) and Croft (2000: passim). The notion of replication is especially useful for analyzing a phenomenon that results from the intersection of cross-linguistic (or cross-lectal) contact and hypercorrection: viz., the pseudo-loanwords that constitute hyperforeignism (and hyperdialectalism); cf. Janda et al. (1994). While the traditional term "borrowing" implies that something can never be borrowed into a language (or lect) A from a language (or lect) B unless it already exists in B, language contact surprisingly often yields "borrowed" words or phrases that are non-existent in the supposed source language. One such example is the English pseudo-Gallicism [ku də grɑ], which, as a pronunciation of supposed *coup de gras* 'stroke of grease,' is a failed copy – motivated

by an overextended belief that “final consonants of French words are usually unpronounced” (as in *coup d'état* ‘stroke of state’) – of the true Gallicism *coup de grâce* “stroke of mercy.” Such pseudo-loanwords can be seen to make eminent sense, however, if we give up the “borrowing” metaphor and instead realize that contact situations often involve attempts to create a replica, in one’s native language (or lect), of a model found in another language (or lect) – whereby this replication may involve considerable distortion. Such an approach is not new; it goes back to Haugen (1950) and Weinreich (1953); for discussion, cf. Janda et al. (1994), plus, on related issues, Janda and Auger (1992).

- 71 As regards these criticisms of punctuated equilibrium, which range from the prosaically polite (as in a discussion of “Parallel gradualistic evolution of Ordovician trilobites”) all the way to the polemical (as in Turner’s 1986 characterization of punctuationalism as “evolution by jerks”), it is not difficult to agree on a core set of references. Cf., for example, Gingerich (1974, 1976), Lande (1980, 1986), Levinton and Simon (1980), Stebbins and Ayala (1981), Charlesworth et al. (1982), Ayala (1983), Dawkins (1983), Maynard Smith (1983), Barton and Charlesworth (1984), Stenseth and Maynard Smith (1984), Turner (1986), Sheldon (1987), Kellogg (1988), Levinton (1988), Hoffman (1989), Dennett (1995), and Ruse (1999, 2000), plus more recent papers. It is worth noting that, in the case of several such critiques (especially Sheldon 1987), punctuationalists have argued that a closer look at the relevant data

supports rather than contradicts the central claims of punctuated equilibrium. At present, however, the most unassailable case of punctuated equilibrium in the biological literature remains that of the cheilostome bryozoans studied by Cheetham (1986) and Jackson and Cheetham (1990, 1994, 1999); to date, it has withstood all challenges.

- 72 Indeed, for a consideration of stasis from a linguistic standpoint, cf. chapter 5 by NICHOLS.
- 73 The other subtype of allopatric speciation (in addition to the peripatric variety, that is) has sometimes been said to involve a “dumbbell” model (since it typically involves the pinching-off of a comparatively narrow, bar-like space that once connected two bulbous lobes of population distribution; cf. Mayr 1963), although Bush (1975) speaks of “speciation by subdivision.” A much more euphonious name for the same phenomenon is *dichopatric speciation*, in which (cf. Mayr 1997: 182–3) “a previously continuous range of population is disrupted by a newly arisen barrier (a mountain range, an arm of the sea, or a vegetational discontinuity)” in such a way that “the two separated populations . . . become genetically . . . different . . . [over] time and . . . acquire isolating mechanisms that . . . cause them to behave as different species when, later, they [again] come . . . into contact.”
- 74 Discussion of this general topic can be found, for example, in Donovan and Paul (1998) and many references there. For a pessimistic assessment of the fossil record surprisingly in line with Darwin’s (1859) views – one replete with implications not only for biological but also for

- linguistic reconstruction – see Hennig (1969: 1–3). Further issues directly related to biological reconstruction, again useful as generators of heuristic comparisons with the reconstructive practices of historical linguists, are discussed in Scotland et al. (1994). Note also Eldredge’s (1985: 69) judging of Cain’s (1954) relief that the “fossil record is not complete” as “odd.”
- 75 Mayr’s own (1942/1982: 120) “biological species definition” is as follows: “Species are groups of actually or potentially interbreeding natural populations . . . which are reproductively isolated from other such groups” (a view which is both critically reviewed and compared with various alternative approaches in Wheeler and Meier 2000). Characterizations of this sort have sometimes moved linguists to suggest equivalences between the biologist’s species and various linguistic constructs, such as *language, dialect, speech-community*, etc. (discussed herein in chapter 24 by WOLFRAM AND SCHILLING-ESTES). Although the intraspecies ability to interbreed might seem at first blush to match mutual intelligibility among (certain) speakers of different dialects within a single language, our own inclination is instead to match species with dialects, and biological “local populations” (or “demes”) with speech communities (or communities of practice). This view receives support from the biological finding (cf., e.g., Mayr 1942/1982) that organisms which are in principle capable of interbreeding so as to produce viable offspring are nonetheless sometimes kept apart by factors that include acquired anatomical characteristics or behavioral tendencies. Thus, for example, a linguistic network is similar to a local population in consisting of members whose close proximity actually allows them to interact with one another, rather than organisms who could potentially interact (if they were brought together) but in fact do not do so.
- 76 Linnaeus’ original (1750) statement of this principle arguably uses a plural form meaning ‘leaps’ as the object of ((*Natura*) *non facit . . .*) “(Nature) does (not) make . . .,” since *saltus* – more unambiguously *saltūs* – is indeed the acc.pl. of the Latin 4th-declension (masc.) noun in question. But other, later writers (e.g., Huxley 1859: 27) tend to follow Darwin’s repeated use (1859: 171, 194, 206, 210, 243, 460, 471) of acc.sg. *saltum* in his invocations of “the canon of ‘*Natura non facit saltum*’, which every fresh addition to our knowledge tends to make more strictly correct” (p. 471). Hence we are entitled to suspect that some intermediary within the line of transmission between Linnaeus and Darwin wrongly believed the former’s *saltus* to be the nom.sg. of a 2nd-declension masc. noun (one parallel to, e.g., *mūrus* ‘wall’) and so – wrongly – treated it as an incorrect case-form which needed to be replaced with “correct” acc.sg. *saltum*. Even linguists sometimes run afoul of the Latin 4th declension – as in Shibatani’s (1976: xii) discussion of theoretical “*apparati*” (versus Latin *apparātūs*) – and this leads one to ponder whether the use of a plural-marking macron on *nexūs* in at least one philosophical work (*A Key to Whitehead* by Sherburne 1966: vi, 72–97 et passim) is

- perhaps not such an extreme solution, after all. We should note that it is not just non-native users of Latin who have been vexed by this problem: Roman writers themselves varied between 2nd and 4th declensions in, for example, using both *domī* and *domūs* as the gen.sg. of *domus* 'house.'
- 77 A linguistic analog of this scenario is unwittingly provided by Dawkins (1986: xvii), who devotes a brief complaint about instances of American English usage that have entered the United Kingdom to grumbling about the failure of young speakers in the United States to describe the prepublication evaluators of a book manuscript as its *referees*: these are, he writes, "not 'reviewers' . . . [.] *pace* many Americans under 40." Here, we can safely assume that an original situation in which a single main sense for *reviewer* reigned within a geographically unitary homeland (England) was later altered by a semantic change that expanded the sense of *reviewer* but occurred only in one peripheral, originally quite small set of British colonies (in North America) – whose citizens have now begun to spread their innovations (like *reviewer* as – also – "book-manuscript referee") back into the ancestral homeland. Thus a change via some form of cross-language or cross-dialect contact – cf. chapter 23 by THOMASON – is at issue here.
- 78 As pointed out in n. 21, this fact – that what change in documents most often reflects directly is the spread of an existing linguistic pattern into writing, rather than the spoken-language origin of that pattern in the first place – leads one to question the validity of Kroch's 1989 "Constant [or: Uniform] Rate Hypothesis [or: Effect]" (discussed here by PINTZUK in chapter 15, as well as by GUY in chapter 8).
- 79 Such timespans in geological terms take on particular interest in light of claims concerning possible temporal limits on the Comparative Method in the range of some 10,000 years; see, on this question, chapter 1 (section 11) by RANKIN and chapter 2 (section 3.3.1) by HARRISON.
- 80 In this connection, it should be mentioned that, as discussed more fully in section 2.3 below, grammaticalization is treated – to varying extents and degrees – by several chapters in this volume.
- 81 Interestingly, Lightfoot (1999a: 81–2) even describes the approach to grammar taken by a quantitative variationist sociolinguist like Labov as being consistently individual (and psychological) – "[a]s claim[ing] that speakers' grammars are psychological/biological entities existing in the minds of individual speakers" – despite Labov's own repeated insistence that understanding either the synchrony or the diachrony of a language requires the formulation of community grammars. For Labov (1994: 45n.2), after all, the conspicuous locus of regularity is the community, not the individual: "a language . . . [i]s a property of . . . [a] speech community," and so we must "avoid a focus on the individual, since the language has not in effect changed unless the change is accepted as part of the language by other speakers." The community-level focus of Labov (1972a, 1994, etc.) is thus indeed much closer to the species-level orientation of Eldredge, Gould et al. than to Lightfoot's concentration

- on individual speakers. Another linguistic study with difficulties in the match-up between linguistic units and purported biological counterparts is Goodenough (1992).
- 82 One reflection of this fact is the principle of comparative reconstruction such that, especially when the change in question seems relatively unnatural (e.g., uncommon) and when the total number of sister languages involved is great, any change which is reflected in all the daughters of a given linguistic ancestor should be analyzed as having occurred once, in that ancestor, rather than individually in each sister. (Of course, considerations of parsimony are involved here, as well.)
- 83 While the heated debate and vigorous controversy that surround punctuationism show no signs of cooling off or quieting down, there appears to have emerged a tentative consensus that at least some speciation events are relatively punctual, while others are relatively gradual (cf., e.g., Geary 1990). Erwin and Anstey (1995a, 1995b), for instance, reviewed 58 previous studies that had been designed and carried out to verify the principal claims of punctuated equilibrium – a sample which not only included analyses representing a wide variety of taxa and periods but also, by its sheer size, tended to overcome deviations of individual studies from the strict criteria which have been advocated as necessary for any true test of punctuationism. Erwin and Anstey (1995b: 7) concluded that “paleontological evidence overwhelmingly supports . . . [the] view that speciation is sometimes gradual . . . [and without stasis, but] sometimes punctuated . . . [between periods of stasis; overall, then,] no one mode characterizes this very complicated process in the history of life”; it should further be noted that a quarter of the studies at issue reported a third pattern: gradualism with stasis. More or less the same divided conclusion regarding punctuationism (versus gradualism) is presented to college students of biology, evolution, and/or paleontology in such introductory textbooks as Futuyma (1979: 701), Strickberger (1990: 273–4), Ridley (1996: 562), Benton and Harper (1997: 52–3), Freeman and Herron (2001: 527), and Stearns and Hoekstra (2000: 274–5). Thus, for example, Strickberger ends his discussion of punctuationism as follows: “This dispute has generated many arguments and counterarguments . . . [;] all evolutionists agree that both gradual and rapid changes occur during evolution. What we have not yet resolved is the relative importance of these changes in explaining speciation and the evolution of higher taxonomic categories” (1990: 273–4). In this regard, one particularly significant finding concerns the fact that, where it exists, stasis does not seem to result from a lack of genetic variability. Avise et al. (1994) addressed this question by sequencing several genes in the mitochondrial DNA of horseshoe crabs (the best known of the so-called “living fossils”) and then comparing the amount of genetic divergence that they found within this clade to a previous study of genetic distances within another arthropod clade – the king crabs and hermit crabs – carried out by Cunningham et al. (1992). The

results were striking: Avise et al. found that horseshoe crabs show just as much internal genetic divergence as the king-/hermit-crab clade, even though the former have undergone far less morphological change over time than the latter.

84 As a parallel botanical example of stasis, Stebbins (1982: 21–2) cites the case of the plane tree, or sycamore, whose American species have quite recently been able to hybridize successfully with their (locally) introduced Mediterranean relatives in parks throughout the northern hemisphere and in the California foothills. This means that, “during the past 20 million years, plane trees that were separated from each other by a distance of 4,000 miles and grew in distinctly different climates have not evolved differences greater than those that distinguish breeds of cattle.” In a nutshell, the visible differences distinguishing them are more extreme than their internal genetic differences.

85 We should note at this juncture that McMahon (2000b) likewise concludes another linguistic work (and one having biological and historical implications, as well) by quoting the last sentence from Voltaire’s *Candide*. This is perhaps also an appropriate place to note that Croft’s (2000) attempt to explain language change on the basis of an evolutionary approach was published recently enough that there has not yet appeared a sufficient critical reaction in the biological, paleontological, or (historical) linguistic literature which would allow us to quantify Croft’s relative success or failure – to date – in his avowed goal of improving historical linguistics

through the admixture of biological terms and concepts. On the other hand, we can already greet with approval Labov’s (2001: 3–34) lengthy discussion of “The Darwinian Paradox” in the second volume (*Social Factors*) of his two-part investigation into *Principles of Linguistic Change*, where we take the author’s increased attention to parallels between biology and linguistics as a positive sign because it represents a convergence with a similar development in our evolving plan for this introduction. Yet Labov (2001), too, has appeared so recently that it has not yet provoked a detectable groundswell of critical reactions in the current literature on biology, paleontology, and (historical) linguistics, and so – for the present – we will forbear from commenting further on the biology-related material in Labov’s book, as well. Finally, we should here issue a blanket statement (covering all of both this and the previous section) that, although we have not always consistently maintained a terminological distinction between talking about change in language(s) and talking about change in grammar(s), we believe that our conclusions here do not depend on the individual choices between these sorts of terms that have been made at particular points in the main text.

86 Recall from n. 75, however, that (local) biological populations – or “demes” – are relatively small-scale units which thus seem to correspond more closely to linguistic networks or speech-communities, rather than to entire languages.

87 Thus, for example, Labov (1994: 98–112) discusses the “stability of individual phonological systems over time.”

- 88 See Butters (1988) for documentation of this item, where it is said to be a “new” form. We regret citing a term of disparagement here (or anywhere), and do so only because it provides such a perfect example of the point that we are trying to make. Fortunately, many epithets of this type are of relatively short currency.
- 89 This usage was overheard by one of the authors (Joseph) at that camp in the summer of 1961.
- 90 Of course, one cannot rule out the possibility of there being some direct conduit for the spread of this usage, or some long-distance medium, such as radio, television, telephones, or the Internet. However, with processes which, like the clipping typical of slang, are quite common, we feel that the burden of proof would be on anyone claiming that there must be a direct connection between the two occurrences at issue. After all, an obvious play on words, for example, can be spontaneously created by several speakers (either in the same or in different locales, and either at the same time or at different times); it need not be the case that one speaker heard it from another. The experiences of Warren Peace, assistant principal at a high school attended by one of us (Janda), are instructive in this regard. Mr Peace reported that, whenever he moved to a new place, he always seemed to meet someone who, without any apparent influence from others, wanted to bestow on him the nickname *Tolstoy*, given the homophony of *Warren Peace* with the Russian author’s famous novel *War and Peace*.
- 91 Such an assumption is parallel to what Gould and Wells are cited as saying in section 1.2.2.2 above regarding “nature’s laws” being “invariant in space and time” (cf. also more generally Braithwaite 1953: *passim*). The trick, of course, lies in determining just what those laws in fact are – that is, for language, in figuring out what the universals are.
- 92 Of course, the history here ultimately involves a borrowing (since *homo-* is from a Greek form meaning “same”), but, as far as many “average” speakers of synchronic late-twentieth-century English are concerned, the connection between the form [hóumòu] and its referent(s) is purely arbitrary. The appearance of *m-* in a slang form of the word, or in two independent slang forms, thus ultimately has a long-term “historical” – that is, a polysynchronic – explanation (involving Ancient Greek, Renaissance-era humanistic borrowings of Greek morphemes into English, etc.), even if the absence of the fuller form’s first syllable from the clipped slang form in the two relevant speech-communities does not.
- 93 Admittedly, Posner’s later discussions (on p. 106 and especially pp. 419–22) tend to contradict this impression.
- 94 Of course, in such a situation, if alterations in one or the other language system occurred due to this external change in sphere of usage, or due to speakers’ changing degree of familiarity with the languages at issue, this would not be surprising, since we would then be dealing with contact-induced language change (see chapter 23 by THOMASON), which is very different from the language replacement described here.
- 95 The ambiguity of *historical* (and *historic*) seems to represent a

derivational continuation of the ambiguity inherent in *history*, which is often defined both as 'a branch of knowledge that records and analyzes past events' and as 'a chronological record of significant events, especially those affecting a people or institution.' These two senses are respectively given as (part of) the second and third meanings of *history* by Mish et al. (1997: 550), which is quite expected, since the practice of *Merriam-Webster's Collegiate Dictionary* is to provide first those senses which are etymologically older in English; thus, the first meaning that this work lists for *history* (attested starting in the fourteenth century) is 'tale, story.' Surprisingly, however, Pickett et al. (2000) list roughly the above meanings in essentially the same order, although this contradicts the usual non-etymological sequencing criteria of their *American Heritage Dictionary of the English Language*. Still, the latter work spells out a much more revealing pre-English etymology for *history*, whose roots extend back first from Middle English *histoire* to (borrowed) Old French *histoire* and thence, via Latin *historia*, to Greek *historía*, meaning primarily 'inquiry, research, or result thereof' (a sense still preserved in the phrase *natural history*) and derived via *historeîn* 'to inquire' from (*h*)*ístōr* 'knowing, learned, wise (person).' The last of these, in turn, has the reconstructed etymon *wid-tor- (compare English *wit*), a suffixed zero-grade form of the PIE root *weid- 'see,' and so is also related to Greek *eidénai* 'to know.'

96 We have ourselves sometimes wondered (usually in a whisper) whether there is not a need for

some label like (antepenultimately stressed) *glossallagology*, from the Greek for 'language,' 'change' (*allagē*), and 'study,' or even *language-change-ology* (since the other major Ancient Greek word for 'change,' *metabolē*, would yield the hopelessly misleading expression *metabolic linguistics*). Unfortunately, we fear that, in a manner reminiscent of Jespersen's notorious characterization of Danish (his mother tongue), such terms – especially the former – might sound more like a throat disease than a serious attempt at conceptual clarification via terminological innovation.

97 As far as we know, a claim of momentous historic status for Templeton would be justified only if the above-mentioned sign at issue were intended to invoke the fact that actor James Dean had his fatal car-crash 25 miles east of nearby Paso Robles, in the even smaller town of Cholame, California, on State Route 46. But this is really quite a stretch as a fact about Templeton, since the crash in question took place at a site located two towns away. The alternative tack of claiming Templeton to be historic on the grounds that it has momentarily arrogated that quality to itself solely by assertion (i.e., claiming that historic status can be gained just by makingchutzpah-filled claims about history) is an intriguing notion, but it is not likely to be what the Templetonians themselves had in mind when they posted their sign. For Templeton's (or at least its Chamber of Commerce's) own views on the town's degree of historicity, see <http://www.templetonchamber.com> (but also <http://www.ridenbaugh.com/travel/crv7.htm>).

98 A relatively recent example of this phenomenon is provided by McCrum et al.'s (1986) *The Story of English* (not to be confused with Pei's 1952 book of the same name), which grew out of a very successful BBC documentary-like series originally made for television but now available in video format. Though this production belongs mainly to the domain of popular media, the public has come to view not only the book but also the filmed series as an extremely scholarly effort – which is especially unfortunate given that, in our opinion, the writers and producers involved in the project failed to provide an adequate overview across the history of English, due to their excessive focus on the putatively colossal contributions to the development of the language made by famous writers like Shakespeare. That is, what got lost in the alternating shuffle between literary luminaries, on the one hand, and sympathetically portrayed, less well-known varieties (like Irish English), on the other, was the pivotal role played over the centuries by the day-to-day conversational interactions and language use of “the English speaker in the street” – in, say, London or Philadelphia.

99 Shortly after writing this paragraph, we learned that Seamus Heaney's (2000) *Beowulf: A New Verse Translation*, had just become a bestseller in Britain. We take this as strong confirmation of our claim that public knowledge of earlier periods in the history of English is essentially limited to the name, or at most a bilingual translation of, only one text per period. Thus, if another famous writer were to

make a vivid Modern English version of the long travelogue by the Norsemen Ohtere and Wulfstan (cf. Lund 1984) that was interpolated into the Old English translation of Paulus Orosius' Latin histories – a translation thought to have been personally supervised by King Alfred (cf. Bately 1980) – it would be unlikely to achieve even moderate sales, although the work in question is generally regarded as one of the most representative specimens of Old English prose.

100 In fact, any accounts that may have been written by historians concerning a sparrow's fall are likely to be more accurate than the majority of historical references to the end of the Roman Empire. The view most commonly encountered (cf., e.g., Benét and Murphy 1996: 883) holds that the last emperor – reigning from AD 475 – was (Flavius Momyllus) Romulus August(u)lus, who in 476 was forced to abdicate by the German general Flavius Odoacer, with the latter then exercising a short-lived rule over a German kingdom of Italy until 492. Grant (1990: 158–60, 215, 238), however, shows that Julius Nepos, Romulus' immediate predecessor as emperor (reigning 474–5), was imperially reinstated in 476 and – as indicated by his appearance on coins minted by Odoacer during this time – was officially recognized as Western Emperor until he was murdered four years later. The little-known truth is thus that the Roman Empire (in the West) did not end until AD 480, and that its last imperial ruler was Julius Nepos (the Grover Cleveland of Roman Emperors, since his tenure in office was interrupted by another's, just like the twenty-second (1884–8) and twenty-fourth

- (1892–6) president of the United States). Hence history proper greatly resembles linguistics (including diachronic linguistics) in that both fields are characterized by the unfortunate situation that most non-specialists and even some specialists “know” many “facts” about them which are not true. (A second, music-historical case of the same sort has to do with the nearly universal belief that Wolfgang A. Mozart regularly used a Latin form as his second name, *Amadeus* – whereas actually he always used the French equivalent, *Amadé*, for more than 13 years of his life, starting when he was 21; see Greither 1962: 7, 9, 49, 63.) Both history and linguistics (as well as their intersection, historical linguistics) thus confirm the wisdom of a comment once made by the Yankee humorist Josh Billings (pen name of Henry Wheeler Shaw): “It is better to know nothing [about a subject] than to know what ain’t so” (cf. Billings 1874).
- 101 However, we must add the caveat that, given the number and complexity of the temporal issues discussed in most of the works just listed (solo as well as anthological), one can only rarely – even less often than in linguistics, we feel – give a blanket endorsement of all the claims or arguments in any individual study. Hence reading through the literature on time produces a kaleidoscopic picture continually altered by the adoption and rejection of relevant notions – some of which, in Augustinian fashion, seem (so to speak) alternately to fade in and out on the edge of cogency and comprehensibility.
- 102 As a concrete example indicative of the literally astronomical number of entities that exist in the universe, consider Dobzhansky’s (1970: 1) report that a single human being consists of “about ten trillion . . . cells,” together containing “some seven octillion . . . atoms” (i.e., seven times ten to the twenty-seventh power).
- 103 Lass (1997: 25) gives an example that makes this point in rather graphic terms that are far more concrete than Hockett’s. Noting that neither the personal existence of the author Charles Dickens during the nineteenth century (1812–70) nor his birthdate (February 29, 1812) is subject to any dispute, Lass states that one reasonably secure inference to make is that Dickens’s (biological) parents engaged in sexual intercourse at some point roughly nine months before Dickens’s birth. While we ourselves do not deny that this inference is entirely reasonable, we note – as does Lass – that its absolute validity is only as solid as such beliefs as that Dickens was not an extraterrestrial and that human parthenogenesis was not possible in Dickens’s parents’ time. (Lass points out that matters would have been much different if Dickens had been an aphid.)
- 104 This also holds for Lass’s Dickensian example (see n. 103): even if a specific event involving Dickens’s parents might not be in question, much is unknown and probably forever unknowable about it, such as the exact moment of the author’s conception, the ambient temperature at that moment, and so on. Collingwood (1928/1993: 484) makes roughly the same point in discussing historical scholars’ tendency “to think that we know ‘all about’ something . . .

- [,] possess a complete knowledge of it, when we know all *that is known* about it" (original emphasis). Collingwood goes on to conclude that, "[o]nce this confusion is cleared up, no historian would hesitate to say that, even in the period that he [or she] knows best, there are infinities of things he [or she] does not know for every one that he [or she] does." Collingwood is extensively cited by Lloyd (1998), whose insightful views we commend to the reader.
- 105 Thus, Sanskrit *nāma* and Latin *nōmen* agree on the length of the first syllable; Greek *onoma*, though, besides adding the problem of its initial *o-* (possibly from a laryngeal consonant), has a short vowel corresponding to the long vowels of Sanskrit and Latin, and bringing in forms for this word from other languages only muddies the waters further as regards the precise shape of the PIE etymon. But no one (it seems) would doubt that the evidence points to there being some PIE form for this word. We can thus contrast this case with the situation which – following Bloomfield (1946) – Hockett (1958: 524–5) describes for Proto-Central-Algonquian (PCA), where the relevant languages "show apparently cognate words for 'gun' and 'whisky,'" but, since these are European "contributions" (so to speak) to the North American cultural scene, and since "Proto-Central-Algonquian . . . antedated the arrival of the Europeans," there can have been no word for 'gun' or 'whisky' in PCA.
- 106 It was Schleicher himself who initiated the systematic (though not the absolute) use of starred forms; cf. Koerner (1975, 1978a: xviii). That is, Schleicher was not the earliest asterisker among historical linguists, but he was the first consistent one.
- 107 We do not really know how Watkins (or anyone other than ourselves) would "vote," so to speak, in this case; however, our suggestion that Watkins might assign a zero to the reconstruction **patis* is based on the assumption that the approach at issue here might tempt scholars to treat particular reconstructions in an all-or-nothing fashion, as it were – that is, by assigning zero (0 percent) to any reconstructed form that is unviable in some way (as, e.g., with the vocalism of **patis*). More generally, though, it is not clear in every instance how such calculations of relative (un)certainly should be made and expressed. Still, the point remains valid that *some* index of (un)certainly would much more accurately reflect the comparative reality of any given reconstruction than asterisks now do. It is thus heartening that probabilistic approaches to reconstruction have recently been gaining greater application in historical linguistics and can now be found in such works as, for example, Renfrew et al. (2000).
- 108 Trask (1996: 208), for example, goes far beyond stating that "the existence of systematic correspondences" allows us to make "at least educated guesses about the sounds that must have been present in particular words in . . . proto-languages." Rather, Trask exuberantly suggests, "we can often . . . work out" (and here he surely means more than "speculate about") all of the following for a purely reconstructed language: (i) "all the ancestral sounds in individual words"

- (original emphasis), (ii) “roughly what whole words *must* have sounded like . . . , and (iii) “what the entire phonological system . . . *must* have been like” (emphasis here twice added to *must*). Trask also earlier (p. 202) speaks of the “methods which linguists have developed in order to . . . recover the histories of individual languages and language families.” On the other hand, Trask (1996: 216–24) deserves considerable credit for devoting a lengthy section to the “[p]itfalls and limitations” of comparative reconstruction – a section whose warnings outnumber by far the few brief caveats provided by most historical linguistics textbook writers.
- 109 Some authors, however, use the time-as-measurement approach as a practical expedient in introductory discussions, and so do not even shy away from the attendant circularities. See, for example, Greene (1999: 37): “It is difficult to give an abstract definition of time – attempts to do so often wind up invoking the word ‘time’ itself, or else go through linguistic contortions simply to avoid doing so . . . [B]ut we can take a pragmatic viewpoint and define time to be that which is measured by clocks . . . , device[s] that undergo . . . perfectly regular cycles of motion.” However, Greene later adds: “Of course, the meaning of ‘perfectly regular cycles of motion’ implicitly involves a notion of time, since ‘regular’ refers to equal time durations elapsing for each cycle.”
- 110 It should be mentioned, though, that British physicist Julian B. Barbour’s views of time lie precisely in this direction, with all times existing simultaneously – but, as it were, in different places.
- The fullest explication of his ideas, accompanied by some discussion of earlier scholars’ arguments for and against, is given in Barbour (2000), but a quite brief though very general overview (simultaneously more focused and less technical) is available in Folger (2000), an interview in which most of the statements are by Barbour. In the latter, he describes his attempt to unify quantum mechanics with general relativity (a submicroscopic scale with a cosmic one) as yielding a theory where “[e]ach instant we live . . . is, in essence, immortal” (p. 58); Barbour calls each such still-life-like configuration a “Now.” Rather than analyzing time as omnipresent, however, Barbour concludes that “there is no time”: “the Nows are not on one timeline . . . , [but] just there,” and, since “[n]othing really moves,” “there is nothing corresponding to motion” (p. 60).
- 111 Quite apart from the question of their (in)validity, we should mention (for completeness’ sake and because this section tends to provoke questions about them) that séances likewise fail to qualify even as potential sources of support for particular linguistic reconstructions, because it cannot be ruled out that the speech of groups and especially communities of spirits would continue to reflect changes vis-à-vis their earlier use of language.
- 112 Even with this substantial list and with those that appear later in the present section, it is obvious that we can here present only a small fraction of the huge literature – pro as well as con, scientific as well as philosophical, scholarly as well as fictional, and serious as well as fanciful – which has so far

- accumulated on the subject of time travel. Hence we cannot pretend to do more here than diffidently follow our own leanings as to how many and which works to describe as representative, and which approaches to present in a more or a less favorable light. We trust that these in part externally and in part self-imposed limitations will meet with the reader's understanding, especially given our strong skeptical conviction that, both for the present and for the immediate future, it is practical considerations (such as the extreme difficulties which currently face all attempts to achieve and survive travel at the speed of light) that will prevent any time travel related to the study of (or, heaven forbid, the manipulation of) language variation and change. We are also well aware that there must be, within linguistics, many diachronicians as well as synchronicians who see time travel as inherently impossible – especially “backwards” travel into even the recent past – due to, for example, the entropy-related consequences of the so-called Second Law of Thermodynamics (tacitly invoked with our mention above of Boltzmann 1872, 1898), behind which there is always, as it were, a certain temptation to hide. We, too, return to at least indirectly entropy-related considerations, once we have finished briefly assessing what, if any, the practical implications of CTCs (= time-related curves; cf below) are for historical linguistics.
- 113 Of course, one might want to redefine “100%” in this context to mean “as certain as one could be,” a realistic step to be sure but not the same as absolute certainty.
- 114 As for unearthly possibilities, we have heard it said that, for an Indo-Europeanist, heaven would involve having a speaker of PIE within earshot all the time – one who is talkative and speaks clearly – while hell would also involve having a speaker of PIE around all the time, except that this time it would be a taciturn mumbler with a perverse delight in talking just out of earshot.
- 115 On this topic, cf. both Wolfram and Christian (1976) and the discussion in Crystal (1995: 315).
- 116 Of course, diachronicians – of language or otherwise – sometimes get lucky (to be frank about it), as in the famous case of de Saussure's (1879) bold hypothesis (when he was barely out of his teens) positing for PIE a set of effect-laden but essentially abstract placeholders (accordingly called by him *coefficients sonantiques* “sonantic [= sound] coefficients”) which have come to be discussed under the rubric of “laryngeals” (for a number of general references, cf. n. 5). That is, de Saussure's conjectures and the reconstructed entities on which they rested were confirmed nearly fifty years later (unfortunately, after the great Swiss linguist's death) through the discovery and interpretation of certain consonants in Hittite, especially after the deciphering achievements of the Czech linguist Bedřich Hrozný (1917, 1919) came to the responsive attention of Kuryłowicz (1927). Discussions of this particularly striking and even dramatic affirmation of how great the value of internal reconstruction can be are available in most standard textbooks on historical linguistics; see, for example, Arlotto (1972), Anttila (1972), Hock (1991b), and

- Trask (1996: 256–60), among many others. It must be noted, however, that even successfully establishing the correctness of certain aspects of an internally arrived-at reconstruction virtually always leaves unknown many finer details (as we emphasize more strongly above, in the next paragraph of the main text).
- 117 Our own preference, however, is to characterize this approach as involving polysynchronic – rather than diachronic or “historical” – explanation; cf. the discussion above in section 1.2.3.2 (more precisely, see n. 68) and especially section 1.2.3.8.
- 118 We say “reconstructed proto-languages” in order to exclude situations like the occasionally encountered practice of referring to Latin as (equivalent to) “Proto-Romance,” which would make the latter an attested proto-language. But, in any case, it is well known that the (“Vulgar”/Popular) Latin vernacular(s) from which the Romance languages arose are only very sparsely attested, and that the overwhelmingly more richly attested variety of Classical Latin does not represent the language state from which most Romance linguistic phenomena are descended. We should also exclude instances of what can be called “intermediate proto-languages,” like reconstructions of Proto-Germanic which draw both on evidence relating to Common Germanic and on comparative evidence from elsewhere in Indo-European, since examples of this sort do seem to have a(n) Indo-European past, although not exactly an intermediate one. Hence we are here mainly focusing on ultimate proto-languages, like PIE itself.
- 119 The strength of the common belief that certain old-looking objects actually belong to the past rather than to the present is backhandedly proven by the vehemence with which present-day people are often tempted to deny the authenticity of historical relics that do not accord with their intuitive notions of what objects were like in the past. For instance, mock-ups which freshen up the remaining traces of paint applied in ancient times to the reliefs on the Parthenon in Athens or to carved rune stones in Scandinavia strike most modern viewers as so gaudy (even if eye-catchingly vivid) that they are automatically assumed to be completely modern inventions – since historically sensitive people “know,” after all, that the dignified ancient Greeks and Scandinavians would never have daubed childishly bright colors on pristine stones. Lowenthal (1985) devotes considerable attention to this point; his book is in fact entitled *The Past Is a Foreign Country* (after a line from a play) as an expression of how we tend to assume that what is associated with a “foreign” time must also have a foreign look different from everything that we are used to in our everyday experience. Still, Lowenthal observes (p. 145): “For valued antiquities to look new is standard practice in the United States. . . . Shabbiness seldom brings history to life; the only way the past can seem real is if its relics are in their prime.” Thus, he points out, the restored and replica buildings in Colonial Williamsburg are, according to Boorstin (1960: 93–4), “as neat and as well painted . . . [and] will never have the shabbiness that

many of them must have shown in the colonial era."

- 120 Santayana's dictum is often "quoted" (i.e., misquoted) as "Those who *refuse to learn from the past* are *doomed to repeat it*" (where italics mark the garbled parts); it has also been parodied by college students as "Those who cannot remember (the lectures from Intro[duction] to) History are doomed to repeat it." Such levity is perhaps not inappropriate for a quote which is so predominantly – and so frequently – taken out of context: that is, Santayana's point was not that history is cyclic, but that knowledge and skills cannot accumulate without a recollected history of memories and traditions. Thus, his preceding clause is (the very ethnocentric): "[W]hen experience is not retained, as among savages, infancy is perpetual" (p. 284). Still, what Santayana is usually (mis)interpreted as having meant was in fact explicitly stated in 1982 by the late Georges Duby, French historian of the Middle Ages, in the course of an interview with journalist André Burguière that was first published in the Paris weekly newspaper *Le Nouvel Observateur* and soon reprinted, in translation, by *World Press Review*: "Knowledge of history is a prerequisite to understanding the present. I concentrate on understanding the 10th to the 13th centuries because, within that period, the information seems rich enough to explore social relations comprehensively. I am convinced that what happened then wrought the mold for our ways of thinking, our behavior, our world view." On the other hand, the earliest major statement along these lines seems to have been made by Niccolò

Machiavelli, writing in the early sixteenth century, who boldly asserted (from the edition by Walker et al. 1970: 517): "[H]e who would foresee what has to be . . . should reflect on what has been, for everything that happens in the world at any time has a genuine resemblance to what happened in ancient times." Still, consider the critical reaction to this by Crick (1970: 50): "[That ']human events ever resemble those of preceding times . . . ['] is common sense, if one allows 'resemble' to mean what is ordinarily meant by 'resemble' . . . [But,] if one chooses to think that . . . [Machiavelli] meant by 'resemble' something like 'are ever determined by', then this is wrong . . . [–] and it is not his view . . . [.] either. . . . Choices can always be made, though they may not be the right ones."

- 121 Some omissions are due to practical space limitations which constrain the physical size of the volume. For instance, just as Spencer and Zwicky (1998) – in the same series as the present volume – provide sketches of various morphologically intriguing languages, our original plan was to include sketches of the main contributions to historical linguistics made by specialists in particular language families or linguistic areas: for example, the fact that, early on, research into the histories of Native American languages by Bloomfield, Sapir, and others convincingly demonstrated the possibility of doing historical linguistic research on non-literary languages. As Bloomfield (1925: 130n.1) put it: "I hope . . . to dispose of the notion that the usual processes of linguistic change are suspended on the American continent (. . . [cf.]

- Meillet and Cohen . . . 1924 . . . [:] 9). If there exists anywhere a language in which these processes do not occur (sound change independent of meaning, analogic change, etc.), then they will not explain the history of Indo-European or of any other language. A principle such as the regularity of phonetic change is not part of the specific tradition handed on to each new speaker of a given language, but is either a universal trait of human speech or nothing at all, an error." Here Bloomfield's views echo Sapir's famous dictum (1921: 219) that, "[w]hen it comes to linguistic form, Plato walks with the Macedonian swineherd, Confucius with the head-hunting savage of Assam." Alas, our going through with this plan would have entailed a much longer volume than would have been feasible. Also, some omissions are due to our having been incapable of finding specialists in certain areas willing or able to finish writing a particular chapter within the allotted editorial time-frame.
- 122 Joseph (2001a) – plus earlier presentations by him cited in Newmeyer (1998: ch. 5) – discusses the epiphenomenality of lexical diffusion and draws parallels between it and grammaticalization as similarly epiphenomenal phenomenon; on the latter, see also Janda (2001a) and Campbell (2001b).
- 123 But see Kiparsky (1976), Wescott (1976), and Kay (1976) for some discussion – relatively brief and somewhat inconclusive – of possible contributions from the field of historical linguistics to the resolution of this question.
- 124 It is not necessarily the case that this is possible. That is, since languages can differ in terms of the various conventionalized inferences that speakers draw from utterances, there can presumably also be corresponding diachronic variation in such inferences. But if, alternatively, pragmatic inferencing turns out to be just a part of some larger logical-inferencing ability possessed by humans in general, then such a system would perhaps not readily undergo or reflect change.
- 125 Despite our present characterization of the field as showing lacunae, we do not intend to downplay the start that a number of scholars have already made on studying various sorts of changes in language use. We would therefore draw the reader's attention both to the recent announcement (in late 1999) of a new *Journal of Historical Pragmatics* and to the somewhat earlier introductory essay in Jucker (1995) by Jacobs and Jucker (1995), which discusses what historical pragmatics in general might entail and what kind of work has so far been done in this area; see, as well, the other papers in that book (plus now also Arnovick 1999; Jucker et al. 1999). Still, many of the articles in the volume at issue are actually synchronic studies of the pragmatics of earlier language states (thus dealing with "old-time synchrony"; see section 1.2.3.10) and so do not really address changes in pragmatics per se. There is also a somewhat older literature on the pragmatic issue of alterations of address systems: see, for example, Brown and Gilman (1960) on the politeness-marking use (with potentially singular reference) of originally plural pronouns in European languages, or Friedrich

(1972) and Scotton and Zhu (1983) on the varying vicissitudes faced by terms meaning “comrade” in, respectively, Russian and Chinese. It is worth noting, though, that some seemingly pragmatic changes do not necessarily represent a qualitatively unique kind of development, but instead appear to be in some sense entirely unexceptional. Thus, for instance, changes in the nature or use of honorifics and other terms of address normally correlate with changes in social customs. For example, many speakers of American English now sometimes employ first names even in encounters with total strangers, as when telemarketing solicitors begin a call by using a first name to address someone with whom they are not on a so-called “first-name basis”! And, at least to some extent, changes in honorification behavior may represent just one type of lexical change.

126 Given (i) the major role played in many languages by intonation as a way to distinguish dislocation constructions (like (*As for*) *The neighbors, they left*) from resumptive-pronoun or even apparent agreement-marking constructions (like *The neighbors they left* or *The neighbors they-left*) and (ii) the fact that specific intonational curves tend to go unrecorded by writing systems, we speculate that such unwritten changes in intonation are at once criterial and yet invisible determinants for the chronology of reanalyses by which dislocation structures yield to agreement-marking ones. For example, a change like this has been discussed as characterizing certain varieties of Colloquial French; see Auger

(1994), who focuses on Québécois but also provides general references. In fact, given our hunch that documentarily invisible intonational shifts like this are frequently and complicitly involved in the demise of particular dislocation constructions, we are tempted to speak of “intonation(al change) – the silent killer,” since it involves a serious sort of change in grammatical blood pressure, so to speak (though perhaps in the direction of hypo- rather than hypertension). Occasionally, though, there exist rare exceptions to the generalization that intonation and related phenomena (like phonological phrasing) tend not to be indicated in written texts. Thus, for example, Fliegelman (1993) discusses the way in which a typographical gaffe by Philadelphia printers carried over into “broadside” copies of the US Declaration of Independence (1776) a reflex of Thomas Jefferson’s private markings as to where he should pause for rhetorical effect if called upon to read the document aloud (since he knew of his reputation as a poor speaker).

127 The Balto-Slavic branch of Indo-European has proven to be an especially rich source for studies of historical accentology and prosody. See Collinge (1985: 271–9) for a summary of several major “laws” pertaining to this area, as well as such recent works as Bethin (1998) and Alexander (1993). On accentual systems in contact, see Salmons (1992) and the many references there.

128 The asymmetry at issue can best be illustrated with reference to tonogenesis – beginning with the fact that this term itself is still unfamiliar enough as a label that

we have overheard linguists exclaim, when they first encounter it in written form: "Look at this obviously metathesized misspelling of *ontogenesis!*" (we are not making this up). The same relative lack of attestations extends to the general referent of *tonogenesis*, as well. At one point in the writing of this essay, for example, we recalled that the 1970s and 1980s had seen a great upsurge of (especially phonetic) research surveying and comparing the origins of tone(s) in various languages; assuming that this trend must have continued up to the present, though beyond our immediate awareness, we considered offering an apology for this volume's lack of a specific chapter on historical tonology. But, when we looked for references to offer in lieu of such a chapter, we found that, in recent years, there has been no book- or even article-length study presenting a *general*, consensus-based overview of the various ways in which tones seem to arise, split, merge, shift (in quality), move (laterally within a word), and the like in the world's languages. Hence it is representative of the current literature on the topic that the chapters here by HALE (7), KIPARSKY (6), JANDA (9), and OHALA (22) only very briefly mention tonogenesis – the last of these, for example, focusing mainly on the relatively early results of Hombert et al. (1979) and on the revisions of its claims required by the later findings of Löfqvist et al. (1989) and of Ohala (1993a: 239–40, 269n.2), among others. In fact, one of the fullest treatments of tonogenesis remains that of Hock (1986: 97–106, 664) (with some references). It may also be noted,

for example, that there is no entry for *tonogenesis* or any equivalent in Bright (1992) and Asher and Simpson (1994); rather, tonal origins are there discussed only in passing – see the respective indexes – and then mainly in connection not with phonology but with phonetics and particular linguistic groupings. Thus, diachronic tonological studies specific to one language or language family continue to appear not infrequently, but the dearth of recent comprehensive works on tonogenesis likewise continues, thereby sounding a low note within the general field of tonology. If any reader with expertise in tonological change is inspired by this non-optimal situation to write a survey article – or, preferably, a book – on tonogenesis, it will surely be met with a high-pitched cry of delight by all historical linguists.

129 See, for example, Swadesh (1950), Gudschinsky (1956), Hymes (1960), Dyen (1973), or Embleton (1986, 1991) for discussion and applications of this methodology. But, like Anttila (1989: 396–8), we here distinguish between glottochronology as a specific notion versus the much more general concept of lexicostatistics.

130 For example, when there is nothing else to go on, glottochronology might make available for further investigations a rough estimate of the time depth (i.e., centuries of separation) between two related language varieties. However, such a last resort would always have to be viewed as the weakest and least reliable source of information available, and so would come into question only under truly desperate circumstances.

- 131 The *locus classicus* disputing the foundations of glottochronology is Bergsland and Vogt (1962); see also the recent negative assessment in Dixon (1997).
- 132 See Benveniste (1969) for an insightful sifting of the linguistic evidence concerning early Indo-European society, all very ably summarized in Mallory and Adams (1997), where can be found (on pp. 290–9) a discussion of the Indo-European homeland issue. On the latter, see also such relatively recent works as Renfrew (1987) – to be read along with the important review by Jasanoff (1988), in which the linguistic side of the claims is addressed – and Mallory (1989). The many books and papers by the late Marija Gimbutas (e.g., Gimbutas 1970, 1985, among others) deserve mention here, too, as does Gamkrelidze and Ivanov (1984). Similarly, there is a long tradition within Indo-European linguistics of the study of early Indo-European poetics, summed up (and furthered) most recently by the masterful work by Calvert Watkins, especially Watkins (1995).
- 133 Two additional questions deserve fuller discussion but are only tangentially addressed in the chapters of this volume. First, given what is now known about individual differences in certain aspects of language acquisition (cf., e.g., Bates et al. 1995 and the relevant parts of Fillmore et al. 1979), is it really legitimate to talk about “the” language-learning child, as is especially common in generative syntax? We would argue that anyone discussing “the child’s” behavior in language acquisition and change must first answer the question: which child? Nor is this just idle stone-throwing on our part, either; rather, what we have targeted here is arguably common practice – note, for instance, the title of Landau and Gleitman’s 1985 book *Language and Experience: Evidence from the Blind Child* (emphasis added). But also, second: “when” is a child? That is, in light of the considerable evidence suggesting that substantially different linguistic behavior can be shown by the same individual at different ages between birth and age 18 (cf., e.g., Vihman 1996 on the concentration of consonant-harmony processes among younger children), is it not crucial to distinguish between and among some maturational equivalents of popular-culture divisions like infants, toddlers, kindergartners, elementary school students, and adolescents? We are hopeful that these matters will come much more saliently to the fore in subsequent collaborations between developmental psycholinguists and historical linguists. As Kerswill (1996: 178) notes, “People of all ages can (and do) modify and restructure their language – though exactly *what* they can change is to some extent age-related”; for a brief, older presentation of an actual case study involving documented change in an adult’s language, see Robson (1975) (cf. also, more recently, Seliger and Vago 1991 on first-language attrition under conditions of contact and language shift).
- 134 It must be recognized, of course, that there may well be no such thing as a totally theory-neutral account, since decisions about categories and labels force one into a theoretical stance, even if only a weak one.

- 135 Works applying the tenets of Optimality Theory (OT) to language change are obviously a relatively recent phenomenon (since OT itself first came into prominence starting in 1993), but they already constitute a not inconsiderable literature (regarding which we thank Randall Gess for references to several articles in addition to his own). Cf., for example – among many others – Anttila and Cho (1998), Cho (2001), Gess (1996, 1999), Holt (1996, 1997), Kirchner (1998), McMahon (2000a, 2000b), Nagy (1996), Nagy and Reynolds (1997), Reynolds (1994), Zubritskaya (1995, 1997), and most of the papers in Hinskens et al. (1997), though see also the critiques in Guy (1997a) and subsequent works. Our own view is that, to date, applications of OT to historical linguistics have tended to demonstrate only that one *can* model diachronic correspondences in a constraint-based approach; they have not yet shown that OT allows many novel insights into language change which were not previously available, nor do they suggest that this new theory brings us appreciably closer to understanding why languages change. In a nutshell, “progress” is not a word that comes to mind when advocates of a theory which employs essentially only constraints and constraint rankings hail as a breakthrough the putative discovery that all language change consists in constraint rerankings. As the saying goes: it comes as no surprise that, to someone whose only tool is a hammer, everything looks like a nail. Still, we remain hopeful that this new century will be marked by OT-based diachronic linguistic studies which are less
- descriptive and more explanatory, especially as they begin to incorporate constraints referring more directly to psycho- and sociolinguistic considerations. For a rudimentary start in the latter direction, see Janda (1998a: 348–9), who advocates positing a family of EMULATE constraints in order to account for borrowing in dialect- and language-contact situations.
- 136 Hopper (1987: 148) expressed such matters as follows: “There is . . . no ‘grammar’ but only ‘grammaticization’ – movements toward structure.”
- 137 In all honesty, we must note what Lass says about our position in Joseph and Janda (1988): “It is so beautifully explicit, and so wrong-headed, that it deserves quotation” (Lass 1997: 10). Needless to say, given our disagreement with Lass’s rather strongly articulated – even extreme – and, for us, similarly wrong-headed views (e.g., on a pseudo-organicist approach to the nature of language; see section 1.1.2 above), we see this book as a whole – and especially this introductory essay – as an answer to his claims.
- 138 As for the alleged dichotomy in linguistics between synchrony and diachrony, Koerner (1974: v) points out that, “[a]s the result of a misunderstanding of Saussure’s true intentions (. . . largely misrepresented by the editors of the *Cours [de linguistique générale]* (1916)), the idea . . . gained widespread currency . . . that synchronic linguistics . . . could . . . be dealt with quite separately from diachronic linguistics . . . [and] that the latter was little more than an accessory to the former which could easily be dispensed with.” But “[c]omparison between the

Cours . . . as edited by Charles Bally and Albert Sècheyay and the critical edition prepared by Rudolf Engler[(1967–8, 1974)] reveals that . . . [,] each time the ‘vulgata’ text speaks of an incommensurability between the synchronic and the diachronic viewpoint[s,] . . . Saussure had merely spoken of a (methodologically important) difference between the two in his Geneva lectures” (Koerner 1974: v.n.*). Nevertheless. “Bloomfield’s *Language* of 1933 followed the model provided by the *Cours*[. . .] in separating these two ‘points de vue’, even to the extent that the historical portion of his book contains no[t a] . . . single cross-reference to anything mentioned in the preceding descriptive section, indeed as if there were two sciences of language entirely divorced from each other and as if one such field could operate satisfactorily without reference to the other” (p. v).

- 139 See also below (in the main text) regarding Japanese *rendaku*, as well as n. 140.
- 140 Other cases of this sort are readily available. For instance, it is well known that prescriptive grammarians can shape language use and hence linguistic form. This occurred in English with regard to, for example, the elimination of double negation among speakers of what is now the standard language. Something similar seems to have happened in German with the use of *ge-* versus \emptyset - in the formation of past participles: an experimental study by Wolff (1981) suggests that the prescriptive rule (requiring *ge-* before verbs having an accented initial syllable, but \emptyset - otherwise) is employed with greater consistency by speakers

with more formal education than by those with less. Finally, in what is perhaps the most dramatic such case, since it hinges on the efforts of a single individual, Ehala (1998) has shown that the declining use of verb-final word order in Estonian subordinate clauses during the first third of the twentieth century, among speakers of all ages, can be traced to the influence of Johannes Aavik, a leading grammarian of the day who championed a “native Estonian” grammatical movement – with verb-final order being considered “an embarrassing German influence,” as Ehala puts it (p. 77). Among other things, Ehala notes that this development seems to show parameter settings being changed in adulthood, an issue bearing directly on the claim that children are the primary instigators of change (especially if one adopts the views of Lightfoot 1991, according to whom change is a matter of resetting parameters; cf. here also LIGHTFOOT’s chapter 14) – but, for a different general view, see AITCHISON’s chapter 25, and the brief discussion in section 2.2 above, plus n. 133.

- 141 The reader must be the ultimate judge, but we believe the strategy of including a plurality of views on individual topics in this volume has given it not only a fullness but also a liveliness of voice. No attempt has been made to tone down what any of the authors have written – including the editors, who are themselves die-hard opponents of the school exemplified by the British diplomatic historian Sir Adolphus W. Ward, co-editor of the “good, gray, . . . excruciating” tomes (cf. Fischer 1970: 296) of the *Cambridge History of British Foreign Policy*

- in the 1920s. Sir Adolphus once complained (as reported by Roberts 1966: 112–13): “I’ve had a bit of trouble with Algernon Cecil’s chapter . . . [; it]’s a bit lively.”
- 142 For instance, besides revised and updated printings of earlier introductions (e.g., a third edition in 2001 of Aitchison 1981), several new introductory textbooks on historical linguistics have appeared in recent years, such as Hock and Joseph (1996), Trask (1996), Campbell (1999), and Sihler (2000), along with some specialized studies, like Nichols (1992a), Labov (1994, 2001), and Harris and Campbell (1995) – each of the latter being (encouragingly) the recipient of one or more book-prizes. Various other books aim at a more general audience of linguists but still have significant diachronic content, such as Dixon (1997), Newmeyer (1998), and Lightfoot (1999a). There have even been some general handbook-like surveys (although not as comprehensive as the present volume), like Jones (1993) and Polomé (1990), among others. For a listing of numerous earlier introductions to historical linguistics (including many works in languages other than English), along with some very brief discussion, see Janda (2001: §3) and references there.
- 143 Earlier book-length starts in this direction have been made in the more versus less distant past by, respectively, Barber (1964) and Bauer (1994). A list of article-length works pursuing roughly the same goals (and dealing with at least one other language besides English) is provided by Janda (2001; cf. especially §8). For discussion of a broadly similar (though by no means identical) trend in anthropology, see the papers in Fox (1991). And, in the field of history itself, Fischer (1989: ix) has provided one of the most eloquent statements of a position which we interpret as essentially identical to that espoused here: “In its temporal aspect, this inquiry seeks a new answer to an old problem about the relationship between the past and the present. Many working historians think of the past as fundamentally separate from the present – the antiquarian solution. Others study the past as the prologue to the present – the presentist solution. This work is organized around a third idea – that every period of the past, when understood in its own terms, is immediate to the present. Th[e] . . . ‘immediatist’ solution . . . in this volume is to explore the immediacy of the earliest period of American history without presentism, and at the same time to understand the cultures of early America in their own terms without antiquarianism.” For more detailed discussion of presentism and antiquarianism – but primarily as fallacies, not “solutions” – see Fischer (1970: 135–42), who discusses numerous other fallacies, as well.
- 144 Foch’s original (telegraphic) French words are discussed in Liddell Hart (1928: 162–3, 1932: 108); as that author concludes (1928: 162), regarding Foch’s report: “If not true in fact, it was true in spirit.”
- 145 Even if this statement strikes some as straddling the boundary between proselytizing and preaching, we at least have consistently tried to practice what we preach. As examples of works referring to both past changes and changes in progress, see Janda (1989, 1998a, 2001a) and Joseph (1981, 1992,

- 2001b); as examples of collaborative works on these and related topics, see (among others) Joseph and Schourup (1982–3), Janda and Varela-García (1991), Janda et al. (1994) and Joseph and Janda (1988), as well as (besides this introduction) the dedication for the entire present volume (within the preface which precedes this essay).
- 146 Taking Labov (1974/1978) as their reference point, at least two subsequent papers have started to ring the changes on his title “The use of the present to explain the past”: thus, Hogg (1997) suggests “Using the future to predict the past” (e.g., by filling in earlier, unattested Old English structures on the basis of later, attested Middle English ones), while McMahon (1994b) proposes “The use of the past to explain the present.” Cf. also the at least partly parallel titles of three purely historical or archeological (i.e., non-linguistic) works: Trigger’s (1973) “The future of archaeology is the past”, Koselleck’s (1979) *Vergangene Zukunft/Futures Passed*, and Blackham’s (1996) *The Future of Our Past*.
- 147 We intend “thick description” in its more literal sense (“richly textured”), as well as in the more contextualized and cognitivist sense adopted by Geertz (1973) from Ryle (1968a, 1968b).
- 148 For such an approach, an extra-linguistic model – worthy of emulation in all respects (not least as a warning as to the potential for external interference) – already exists in the work of the evolutionary biologist Henry Edward Crampton (1917, 1925, 1932), who “spent fifty years documenting the *current* geographic distribution and variation of [the land-snail genus] *Partula* on Tahiti, Moorea [(the inspiration for Rodgers and Hammerstein’s “Bali Hai”)], and nearby islands,” in order to record, not just “a frozen snapshot, but . . . [a] moment in the future history of [the several species of] *Partula*”; cf. Gould’s (1993) forebodingly titled “Unenchanted evening” (pp. 33–4; original emphasis). All told, Crampton personally measured more than 200,000 snails (with at least four length measurements just on each shell) and hand calculated all the statistics (in some cases, to eight decimal places), thereby ensuring that the “personal coefficient” was uniform throughout his research (Gould 1993: 32). “Crampton devoted this lifetime of effort . . . to establish[ing] a baseline for future work . . . [:] *Partula* would continue to evolve rapidly, and . . . [this] baseline would become a waystation of inestimable value . . . [, since f]uture changes have much more value than current impressions” (Gould 1993: 34; original emphasis). And, indeed, Murray and Clarke 1980 (respectively an American and a Britisher, working in collaboration with the Australian Michael Johnson) were later able to build on Crampton’s start at making *Partula* into effectively a museum and a laboratory of speciation. Here is truly a lesson and an example to inspire all those who study innovation and change – linguists in particular! Alas, the end of this story provides an additional lesson: *Partula* has completely disappeared from Moorea, and almost completely from Tahiti, because the “killer” snail *Euglandina* from Florida –

introduced on these islands by local authorities in an attempt to eliminate an adventitious snail – has instead devoured *Partula*, presumably ending forever its evolution there (cf. Gould 1993: 35–9). “Crampton’s work is now undone,” but “[w]hat is more noble than . . . intellectual dedication . . . [to] a lifetime of persever[ing] . . . through . . . field biology[’s] . . . occasional danger and prolonged tedium” (Gould 1993: 40) in order to “establish . . . a starting point, with utmost care and precision, so that others . . . [can] move the work forward and continue to learn about evolution by tracing . . . future history”? By replicating (as closely as possible) the model provided by a scholar like Crampton (1875–1956), even linguists will be able not only to honor his memory but also to help turn his apparent defeat into vicarious triumph – though the spread of such a deliberate approach, and the gathering of such rich documentation, may at first seem to be advancing at a snail’s pace.

149 Given the abysmal track record of attempts to predict change simultaneously on a large scale and over the long term (cf., e.g., Popper’s devastating 1961 critique of Toynbee’s 1935 proposed “laws” governing the “life cycle of civilizations”), what we advocate for historical linguistics is the formulation and testing of predictions regarding either (i) specific phenomena over longer periods of time or (ii) complex (or general) phenomena over shorter periods of time. We have already stuck out our own necks and made two distinct predictions of the first type (cf. Janda 1991 on the

probable continuing spread of -s plurals on nouns in Modern High German, and Janda et al. 1994: 80 on predicted future developments involving (alveo)palatalization of English /s/ before clusters like /tr/, as in *stress* (pronounced as if *shtress* – see now Janda and Joseph 2001 for more discussion)). As regards the second prediction-type, one goal for linguists to aspire to is the current ability of meteorologists to make extremely accurate predictions regarding local weather for relatively short periods of time (e.g., up to five days in advance – whereby the linguistic parallel to this would more appropriately be five years or, better, five decades). In this regard, we are much more sanguine than Posner (1997: 107) – who, though “less pessimistic than . . . [Lass (1980a, 1997)] about the possibility of expla[i]n[ing] . . . linguistic change,” still views “language . . . as a dynamic system . . . in the sense of an evolving ensemble where variation of a parameter produces a change of state, as in a meteorological or population system.” “In such systems,” Posner laments, “the number of variables is so large that accurate fine-tuned prediction is virtually impossible, although it is feasible to model the systems in such a way that some useful results can be obtained.” We are likewise more hopeful than Lightfoot (1999a: 267–8); while agreeing that it is probably not productive now to attempt predictions regarding the “distant end results of language change” (emphasis added), we are convinced that historical linguists can succeed at more than “offer[ing] interesting explanations of changes as they take place, in the fashion of a weather forecaster . . . [.]

- understand[ing] particular changes and explain[ing] them . . . as they happen.”
- 150 To present this apparently anti-quotational quotation from Emerson without context is actually unfair to those who quote. Emerson precedes this remark with: “*Immortality* . . . [:] I notice that . . . [,] as soon as writers broach this question . . . [,] they begin to quote.” This suggests that he was mainly criticizing authors who discuss the subject of immortality without having any real experience with it – and so are forced to cite other writers on the topic (who also lack the relevant experience . . .). We ourselves quote no one on the latter topic (since our lack of related background makes us subject to Emerson’s dictum), but we have considerable experience in quoting, and so feel entitled to cite Emerson’s opinion on the matter.
- 151 On the history of both quotation-sourcing and reference-free footnotes, especially in historiography proper, see Grafton (1997). Although the series in which the present handbook appears uniformly employs endnotes, rather than literal footnotes, the *style* of quotation is the usual linguistic one in which notes never contain only references, but always some content. The wisdom of the latter practice is shown by Hume’s (1776, quoted from 1932: 313) reaction to the purely referential endnotes in the first volume of Gibbon’s (1776) *History of the Decline and Fall of the Roman Empire*: “One is . . . plagued with . . . his Notes . . . [in] the present Method of printing. . . . When a note is announced, you turn to the End of the Volume . . . [,] and there you find nothing but the Reference to an Authority. . . . All these authorities ought only to be printed at the Margin or Bottom of the Page” (what Hume recommended is also the style of Grafton 1997).

Part II
Methods for Studying
Language Change

This page intentionally left blank

1 The Comparative Method

ROBERT L. RANKIN

The comparative method is a set of techniques, developed over more than a century and a half, that permits us to recover linguistic constructs of earlier, usually unattested, stages in a family of related languages. The recovered ancestral elements may be phonological, morphological, syntactic, lexical, semantic, etc., and may be units in the system (phonemes, morphemes, words, etc.), or they may possibly be rules, constraints, conditions, or the like, depending on the model of grammar adopted. The techniques involve comparison of cognate material from two or more related languages. Systematic comparison yields sets of regularly corresponding forms from which an antecedent form can often be deduced and its place in the proto-linguistic system determined. In practice this has nearly always involved beginning with cognate basic vocabulary, extraction of recurring sound correspondences, and reconstruction of a proto-phonological system and partial lexicon.¹

1 The Goal of the Comparative Method

Kaufman (1990: 14–15) states: “The central job of comparative-historical linguistics is the identification of groups of genetically related languages . . . [and] the reconstruction of their ancestors.” He continues (p. 31): “it should be clear that while archeology, genetics and comparative ethnology will help flesh out and provide some shading in the picture of pre-Columbian . . . Man, it is comparative linguistic study, combined with some of the results of cross-cultural study, that will supply the bones, sinews, muscles, and mind of our reconstructed model of early folk and their ways.” Linguistic reconstruction is one of our primary tools for learning about the prehistoric past. In many ways it is our best, and this is especially true at time depths where archeology has trouble identifying the ethnicity of its subject matter. Archeology is our best tool for recovering material culture – settlement patterns, dwelling types, tools,

subsistence, and related information – but it contributes much less to our understanding of what archeologists call *ideoculture* and *socioculture*.² These are areas in which linguistic reconstruction is potentially much more productive. The comparative method is our primary tool for arriving at such linguistic reconstructions.

While the principal goal of most linguists who are also historians has been to learn as much as possible about earlier languages and about past cultures through their languages, other branches of linguistics have benefited a great deal from the by-products of comparative work. Many who are philosophically synchronic linguists have looked to comparativists to inform them about the possible types and trajectories of language change. The study of attested and posited/reconstructed sound changes has played an important role in the formulation of notions of naturalness in phonological theory, and modern theories of markedness and optimality often rely, implicitly if not explicitly, on historical and comparative work. The same can be said for the establishment of the grammaticalization clines that result from much morphosyntactic change.³ Our understanding of the complexities of the synchronic polysemy often associated with grammaticalization is informed by the study of attested and posited intermediate steps in their histories. To a lesser extent the same may be said of semantics and semantic change. But such essentially typological studies may not be considered by some historical linguists to be one of the goals of the comparative method per se. They are important bonuses that result from a consistent and thorough application of the method to families of languages, but they will not receive much additional coverage in this chapter.

2 Why Does the Method Work?

The comparative method relies on certain characteristics of language and language change in order to work. One important factor is, of course, the arbitrariness of the relationship between phonological form and meaning (non-iconicity). To the extent that the linguistic sign is arbitrary, sound change can operate unhindered and will normally be rule governed. Where iconicity is present (in sound symbolism, nursery terms, onomatopoeia) normal change may be impeded or prevented.⁴ Linguists therefore avoid comparison of such items until the basic correspondences among the languages being compared are understood.

A second factor is the regularity of sound change.⁵ To the extent that sound change is regular, we can, with the help of phonetics and an understanding of sound change typology, work backward from more recent to earlier stages. And indeed most phonological change ends up being change of articulatory habit, that is, rule change, and thus ultimately regular. Fairly salient interference is required in order to breach such regularity.

Recognition of regularity and of the role it plays in reconstruction has been considered both a strength and a weakness of Neogrammarian linguistics. It has most often been considered a strength because, of course, without ultimate regularity there can be no phonological reconstruction. It has sometimes been considered a weakness of the Neogrammarian position, however. Beginning with Hugo Schuchardt (1885) and continuing until the present, analogical extension of changes and the pervasive role of dialect borrowing with resultant diffusion of forms has occupied many linguists, dialectologists, and creolists.⁶ Copious amounts of ink have been spilled in discussions of the extent to which the Neogrammarian "hypothesis" is really "true." But, as most Indo-Europeanists have always known, the exceptionlessness of sound change was not so much a hypothesis for Neogrammarians as it was a definition. Those changes that were sweeping and observed after several centuries to be essentially exceptionless qualified for the term *Lautgesetz* (sound law), while changes that seemed to affect only particular words or groups of words did not so qualify.⁷

Most linguists believe that change in articulation begins as a geographically and/or socially limited but regular, unconscious, and purely phonetic process, which then spreads by several different mechanisms, including dialect borrowing (social and otherwise) and rule formation during the language acquisition period in children, until regularity over a greater area is achieved. A perceived dichotomy in the methods of diffusion has variously been described as *sound change* versus *borrowing and analogy* (the terms traditionally favored by most comparativists), *primary* versus *secondary* sound change (Sturtevant 1917: chs 2 and 3), *actuation* versus *implementation* (Chen and Wang 1975), and others, although the pairs of terms do not always correspond 100 percent. The precise extent to which ultimate regularity results from, or is independent of, dialect borrowing doubtless varies from language family to language family.⁸ As a practical matter, comparative linguistics generally involves compilation and analysis of the reflexes of sound changes that occurred, diffused, and regularized long ago. Within comparative Indo-European linguistics the problem of variability within sets of reflexes has not been acute. Whatever the mechanisms that contribute to ultimate regularity in particular instances, its existence, although sometimes obscured by diffusion and analogy, is not seriously disputed and is of primary importance for operation of the comparative method.

3 Family Tree and Wave Diagrams of Language Relationship

The comparative method was developed for the study of the well-defined and quite distinct linguistic subgroups of Indo-European, so comparanda there have tended to be similarly well defined. Obviously such definition is not

always possible (and some might argue that it seldom is). Clearly there are language families (e.g., northern Athabaskan, Muskogean, some Austronesian) in which some unique subgroups are difficult to specify with clarity.⁹ This has given rise to another red herring frequently encountered in discussions of the comparative method, namely the assumption that it must be based on some inflexible notion of *Stammbaumtheorie*. And here again much ink has been spilled by amateurs wondering which theory, the family tree (*Stammbaum*) or the supposedly competing wave theory (*Wellentheorie*), is “true.”¹⁰ Both are true. But they are oversimplified graphic representations of different and very complex things, and it seems hyperbole to call them theories in the first place. One emphasizes temporal development and arrangement, the other contact and spatial arrangement, and each attempts to summarize on a single page either a stack of comparative grammars or a stack of dialect atlases. Neither is a substitute for a good understanding by the linguist of both the grammars and the historical, social, and geographical interrelationships found among his or her target languages. The comparative study of languages or dialects that are arranged in chains or other adjacent or overlapping continua is certainly a challenge, but it is a challenge to the linguist rather than to the method.¹¹

4 Uniformitarianism

Lastly, the method also relies on the more general scientific notion of *uniformitarianism*, here the understanding that basic mechanisms of linguistic change in the past (e.g., phonetic change, reanalysis, extension, etc.) were not substantially different from those observable in the present. Most linguists operate with this as a given and it has not received detailed treatment in most studies of language change, but without the assumption of uniformitarianism, reconstruction would not be possible (Allen 1994: 637–8).¹²

5 Steps in Application of the Comparative Method

The comparative method proceeds in several recognizable stages, which in practice overlap considerably. Internal reconstruction is useful when applied to the daughter languages initially and may also be practiced at various points along the way (see Ringe, this volume). There is relatively little in the way of strict ordering of procedures. A relatively full comparative treatment of a family of languages would include most or all of the following, beginning with the discovery of cognates, both lexical and morphological, and concomitant confirmation of genetic relationship.¹³ Most of these topics are discussed below.

- i *Phonological reconstruction:*
 - a Extraction of phonological correspondence sets.
 - b Classification of sets by articulation (place/manner).
 - c Preliminary reconstruction of proto-phonemes.
 - d Distributional analysis of proto-phonemes; collapse of complementary sets.
 - e Assignment of phonological/phonetic features to proto-phonemes (the reality debate).
 - f Possible adjustment of reconstructions in line with typological considerations (in Indo-European, issues such as laryngeal theory and, more recently, glottalic theory).
- ii *Reconstruction of vocabulary per se:*
 - a Reconstruction of structured lexical and semantic domains within vocabulary such as kinship or numeral systems, in which reconstruction of certain members of the system may enable additional reconstruction of less well-attested or even missing cognate sets within the same system.
 - b Possible semantic reconstruction of cells in a structured matrix even if lexical material is lacking.
- iii *Reconstruction of morphology to the extent that morphological reconstruction is merely an extension of phonological and lexical reconstruction:*
 - a Paradigmaticity may materially aid in reconstruction where cognate morphemes are poorly attested.
- iv *Reconstruction of syntax.*

5.1 Cognate searches

In order to undertake any comparison at all one must have something to compare. The search for cognate vocabulary is, oddly enough, usually the single most challenging task facing the comparativist. If the linguist has already established the existence of a genetic relationship between two or more languages (see Campbell, this volume), she or he has already located a certain number of important cognates. These are normally searched for among the most basic of inflectional forms and among the most basic vocabulary items. A list of 100 or 200 basic words is often used initially in cognate searches, the idea being that basic concepts are the least likely to have been borrowed. We have learned that any such list should be used with care, however, and then only after careful attention to known areal phenomena in the zone where one is working. In English around 10 percent of such basic vocabulary is borrowed, mostly from French. In East and Southeast Asia, though, it is well known that even the most basic numerals are often borrowed from Chinese. In table 1.1, note that the first four languages are related, while the last three are not. Such known vulnerabilities should obviously be considered and avoided, something that was often not possible a century ago but which is often possible today.

Table 1.1 Basic numerals in East Asian languages illustrating both cognates and loanwords

Numeral	Tibetan	Chinese I	Chinese II	Burmese	Japanese	Korean	Thai
'one'	ciq	i	či	tiʔ	iči	il	ʔet
'two'	ñii	ər	nəŋ	hniʔ	ni	i	(sɔ̀ɔ̀ŋ)
'three'	sūm	san	sā	'θouŋ	san	sam	sàám

Atypical syllable structures, clusters, and marginal phonemes are obviously suspect also.

Regularly corresponding phonemes in basic vocabulary and in basic grammatical formants (if typology permits, preferably in paradigms) are the goal. The affixal morphology searched should be largely inflectional, as derivational morphology is borrowed relatively easily and can wait until basic regularities have been worked out.

5.2 *Phonological reconstruction: comparanda*

The question of comparanda in phonological reconstruction is important and is one of the most underdiscussed questions in the literature: one obviously must know what to compare at all levels. The degree of abstraction of the comparanda used in phonological reconstruction is significant and can have important implications, both for relative ease of application of the comparative method, and for the accuracy of reconstructions. Technically one could compare transcriptions of virtually any degree of abstractness from a tight phonetic notation that reveals the greatest degree of lectal and individual variability to a highly abstract underlying and underspecified phonological representation in which only the non-predictable features are noted. There are good reasons to choose neither of these extreme alternatives, however.

It is not the primary job of the comparativist to document superficial dialect variation, and subphonemic variability should usually be factored out of transcriptions used for comparison (although it can be very valuable in charting sound change trajectories). Variable dialect data turn out to be much less variable if they are first phonemicized.¹⁴ Thus, even though the comparative method is in principle capable of dealing with any number of variant forms, it is simpler to introduce a degree of abstraction that eliminates as many as possible without compromising necessary distinctions. Degree of phonological abstraction then becomes a question the comparativist must address.

The usual way in which the number of comparanda is reduced is to perform a preliminary internal reconstruction on the data of each of the languages to be compared before attempting to use the comparative method. This reduces

(or eliminates) allomorphy and makes further comparison simpler. Phonemicization is an obvious first step in such reduction.

Changes in synchronic phonological theory since about 1960 have clouded the picture somewhat. Only two levels of notation have been significant in most generative phonologies, the underlying phonological and the surface phonetic. We have already eliminated the phonetic as excessively detailed, but the underlying turns out to be unsuitable for comparisons also.¹⁵ This is because the procedures generally used for arriving at synchronic underlying notation, although they often do lead to results that look superficially like reconstructions, can sometimes lead the analyst in an ahistorical direction. The resultant abstract phoneme may look like the results of an internal reconstruction, but internally reconstructed and merely abstract phonemes can differ.

Numerous authors have noted the similarity between the procedures of internal reconstruction and those used for abstracting underlying segments. It is often claimed that the procedures are really the same (e.g., Fox 1995: 210). Both procedures do involve treating allomorphs as cognates (which, internally, they are), but synchronic phonological theory places a high value on *productivity*, which may in turn be the result of analogical change, whereas internal reconstruction stresses the importance of irregularities, often so rare that synchronic phonologies would merely assign them an exception feature of some kind. The least productive and most irregular alternations are often the most revealing for the comparative linguist, but the most productive and least irregular alternations are the ones that best serve the synchronist. So the two methodologies may lead in different directions and should be kept distinct.

So it would seem that the comparativist must begin with something not far removed from the conservative notion of surface phonemes, and that abstraction beyond cover symbols for the most automatic of alternations must be treated as an avowedly historical procedure and justified by a careful and explicit application of internal reconstruction.¹⁶ The use of some variety of surface phonemes as comparanda at once eliminates the most superficial levels of lectal variation while preventing a confusion of internally reconstructed with merely underlying forms.

5.3 Correspondence sets and phonological reconstruction

Phonological and lexical reconstruction proceeds according to the procedures outlined above. Take, for example, the cognate sets from several Siouan languages shown in table 1.2.¹⁷ The sets of stop correspondences that can be extracted from these are shown in table 1.3. Major subgroups here are separated by a solid line and minor subgroups within the central Mississippi Valley subgroup by a broken line.

The comparative method requires that these sets recur regularly in a great many other basic Siouan words. With that requirement fulfilled, we see a

Table 1.2 Cognate sets from Siouan languages

Language	'fire'	'four'	'blue/green'	'throw'	'mark'	'bison'
Crow Hidatsa		šo:pá to:pá	šu:- tóʔo-	kuss-	-ka:xi -ka:xE	bišé: wité:
Mandan	pte	top	toho-	-kų:te	-kax-	pti:
Dakotan	phéta	tópa	tho	khuté	káyA	pte
Winnebago Ioway-Otoe	pe:č phé:je	jo:p do:we	čo: tho	khú:je	ga:x gá:xe	če: che:
Dhegihan:						
Omaha	ppé:de	dú:ba	ttúhu	kkí:de	gá:ye	tte
Kansa	ppé:je	dó:ba	ttóho	kküje	gá:ye	čče
Osage	hpé:ce	tó:pa	htóho	hküce	ká:ye	hce
Quapaw	ppétte	tó:pa	ttóho	kkítte	ká:ye	tte
Biloxi	peʔti	topa	tóhi	kité		
Ofo	aphéti	tópa	ithóhi			
Tutelo	pé:ti	to:pa	oto:	kité:		

Table 1.3 Sets of stop correspondences from table 1.2

Language	I	II	III	IV	V	VI	VII	VIII
Crow Hidatsa		š t	k	p p	š t	k k	š t	
Mandan	p	t	k	p	t	k	t	t
Dakotan	ph	th	kh	p	t	k	th	t
Winnebago Ioway-Otoe	p ph	č th	kh	p w	ǰ d	g g	č čh	č ǰ
Dhegihan:								
Omaha	pp	tt	kk	b	d	g	tt	d
Kansa	pp	tt	kk	b	d	g	čč	ǰ
Osage	hp	ht	hk	p	t	k	hc	c
Quapaw	pp	tt	kk	p	t	k	tt	tt
Biloxi	p	t	k	p	t			t
Ofo	ph	th		p	t			t
Tutelo	p	t	k	p	t			t

pattern emerging among the correspondence sets (in spite of the fact that some of the sets here are incomplete because cognates have not been found in some subgroups). There are two sets of labial stops, two sets of dentals (we shall return to sets VII and VIII momentarily), and two sets of velars. And where they differ, they seem to differ by a feature of aspiration or gemination. If we assume that the gemination is secondary and comes from total assimilation of the *h* portion of the stop to what it is adjacent to (i.e., *hC* > *CC* in the Dhegihan subgroup), then it appears probable that we should reconstruct an aspirated and a plain (non-aspirated) set of stops for each of the three places of articulation. To do this, however, we must answer several questions. Were the Proto-Siouan aspirates pre-aspirated, *hC*, or post-aspirated, *Ch*? Were the plain stops voiced or voiceless? What kind(s) of general evidence should we look for and consult in answering these questions?

5.4 Geographic distribution and reconstruction

Meillet (1964: 381, 403) required that cognates be present in at least three distinct subgroups in order to qualify for reconstruction within Indo-European. Obviously the applicability of such a requirement will vary with the size of the language family. Within Siouan, post-aspirated stops are found in Dakotan, Ioway-Otoe-Winnebago, and Ofo. Pre-aspirated or geminated stops are found only in the Dhegiha subgroup (Omaha, Ponca, Kansa, Osage, and Quapaw) of Mississippi Valley Siouan. So the type of aspiration found in Siouan cross-cuts well-established subgroup boundaries. Ordinarily, distribution of post-aspiration in two or more major subgroups would be a pressure toward reconstruction of that feature. Not only are pre-aspirates in the minority but they are found only in one small subgroup of central Siouan. In this instance, however, it is instructive to note that additional factors intervene and cause Siouanists to reconstruct the minority preaspirates.

There are synchronic rules in Dakotan, Ioway-Otoe-Winnebago, and Ofo which reverse *h-C* sequences when they occur in clusters at a morpheme boundary. So Dakotan **mǵah-* 'earth' + *-ka* 'nominalizer' gives [mǵakha]. The clinching argument is that there are additional, conflicting cognate sets which contain real post-aspirated stops. A few of these may represent borrowings, but if they are borrowings they are very old as they are represented in virtually all Siouan subgroups. They include 'cow elk, grizzly, mosquito', and numerous other terms. These problems are discussed in Rankin (1994) and in Rankin et al. (1998). Lastly, there are post-aspirates that arise morphophonemically, and they behave differently from our pre-aspirated sets. So it is the minority pattern, *hC*, that is reconstructed, and, as often happens in comparative linguistics, the qualitative evidence outweighs the quantitative. These cases also serve to illustrate the importance of the comparativist's knowing the synchronic grammars and phonologies of his or her target languages.

The second group of stop correspondence sets shows generally similar articulations but lacks the aspiration. Several languages voice the simplex stops,

but voicing is inconsistent even within the smallest subgroups, and philological evidence of variation in the transcription of voicing in the eighteenth and nineteenth centuries strongly suggests that it is recent.

So the comparative method leads us to reconstruct three places and two manners of articulation for Proto-Siouan stop consonants. Given the above discussion, these are fairly transparently **hp*, **ht*, **hk* and **p*, **t*, **k*. Nothing that could be called guesswork was involved.

5.5 *Complementarity and reconstruction*

Returning to sets VII and VIII, we see that these groups overlap III and IV, the **ht* and **t* sets, somewhat. Examining all such cognate sets it emerges that sets III and IV nearly always precede non-front vowels, while VII and VIII nearly always precede *i* or *e*. Thus III and VII are complementary, so are IV and VIII, and we are entitled to collapse them into two sets and reconstruct a single stop for each, thereby deriving one set as a positionally determined “alloset” of the other. Such distributional analysis and amalgamation of sound correspondence sets is what Hoenigswald (1950) called the “principal step in comparative grammar.”

5.6 *Naturalness and typology in reconstruction*

Linguists often appeal implicitly or explicitly to sound change typologies and the notion of naturalness when deciding among several possibilities for reconstruction. In the complementary Siouan sets, we are dealing with a relatively shallow time depth and a common and relatively transparent palatalization of dentals preceding front vowels. It is important to note, though, that our reconstruction, however easy, is actually being informed by an understanding of phonetic naturalness that, in turn, is derived historically from the combined knowledge of the sound changes that have occurred in hundreds of languages worldwide.¹⁸ It was largely the study of such changes that indicated to early phoneticians such as Eduard Sievers, Paul Passy, and Maurice Grammont just where they would need to search for the kinds of articulatory and acoustic explanations to which we appeal today. One must know what requires explanation before one may explain it. The study of sound change has consistently provided the raw material for phonological typologies and phonetic explanation. And comparativists, in turn, use these constructs in their hypotheses about sound change trajectories and in their reconstructions.¹⁹

5.7 *Reconstruction of lexicon*

Working from these and other sets (which account for the remaining vowels and consonants in the cognates), we are able to reconstruct entire lexemes for

most of the cognate sets. In a few instances independent derivation within particular subgroups or languages prevents us from reconstructing more than the root morpheme. The reconstructions thus far are Proto-Siouan: **ahpé:te* 'fire', **tó:pa* 'four', **ihtó:-* 'blue/green', **hkú:te* 'throw', **ká:xe* 'make marks', **wihté:* 'bison cow'.

Caution is in order, of course. The examples above were chosen carefully in order to represent fairly what is usually encountered in Siouan languages. These languages abound in simple lexemes of the sort reconstructed here. Even though Siouan is not polysynthetic in structure, there are both nominal and verbal compounds. One of these is a term for distilled spirits: 'fire-water':

Winnebago	pé:ǰ-ní:
Ioway-Otoe	phéh-ñi
Omaha	ppé:de-ni
Ponca	ppé:de-ni
Kansa	ppé:ǰe-ni
Osage	hpé:te-ni
Quapaw	ppétte-ni

These examples illustrate the danger of reconstructing other than simple lexemes. Each is a compound of native reflexes of **ahpé:te* 'fire' and **wirǰ* 'water.' But of course the Siouan-speaking peoples did not have distilled liquor until post-contact times, and the compound came about either through parallel innovation, based on the properties of the liquid, or through contact with Algonquian-speaking peoples to the east who had a similar compound (equally non-reconstructible) from which the Siouan could easily have been loan-translated. It could even represent a back-translation by whites of the Algonquian pattern.

5.8 Residual problems in reconstruction

There are certain trends that are not visible from the few examples of reconstruction given above. Let us examine a couple of additional phenomena within Siouan that challenge the comparative method in different ways. The method can be defeated by mergers or loss of phonemes in the proto-language. Often, though, linguists must deal with a certain amount of suggestive residual evidence of phonological split that has been left behind. In Siouan linguistics just such a case is often called the "funny-R problem." There are two, somewhat overlapping, sets of liquids. One is reconstructible as a simple **r*.²⁰ In the other set we find a number of strengthened sonorants and this set is reconstructed provisionally as **R* (table 1.4).

'Wash' and the many words like it are reconstructed with **r*. But 'Indian potato' and 'beg' show the other resonant set. **R* often seems to occur in a cluster following the reflex of Proto-Siouan **w*, as in 'Indian potato.' If this

Table 1.4 The “funny-R problem” in Siouan linguistics

Language	‘wash’	‘Indian potato’	‘beg’
Proto-Siouan	*ruša	*wi-Ro	*Ra
Mandan	rusaʔ-		
Lakota	yužáža	blo	la
Dakota	yužaža	bdo, mdo	da
Ioway-Otoe	ruya	do:	da
Winnebago	ruža	do:	da
Omaha	điža	nu	na
Kansa	yüža	do	da
Osage	đüža	to	ta
Quapaw	diža	to	ta

Table 1.5 Deictic particles in Siouan languages

Language	‘this, here, now I’	‘this, here, now II’
Proto-Siouan	*re(ʔe)	*Re(ʔe)
Crow	-le:-	-né:
Mandan	re	
Lakota		le
Dakota		de
Ioway-Otoe		je-
Winnebago		de: ~ deʔe
Omaha	đe	
Kansa	ye	
Osage	đe	
Quapaw	de	
Biloxi	de	né-
Ofo		le-
Tutelo	lé:	né:

were true everywhere, we could collapse the sets, but in numerous other cases there is no trace of *w, which is from an old nominal prefix, or evidence of any other cluster. Yet it seems that *R is somehow related to *r because of their partial complementarity and because of the sets of deictic particles shown in table 1.5, in which the semantic necessity of some sort of historical relationship is clearer. Note that in some languages doublets for these deictics are common.

At the moment there are enough cases of **r* and **R* in apparent contrast that Siouanists feel constrained to reconstruct both. Yet there is a strong suspicion that **R* was secondary and that it developed from **r* in a cluster with a preceding resonant or glide. Mandan shows a $\emptyset r$ cluster in one or two such cases, but in many cognate sets (such as “beg”, above) there is simply no trace of the hoped-for cluster, and if we follow the comparative method strictly we are left unsatisfied. New data or internal reconstruction may help resolve the question.

5.9 *The question of phonetic realism in reconstruction*

Since the principle of distinctiveness became dominant in phonology, the goals of comparativists have revolved around reconstructing those segments or features deemed to be distinctive in the proto-language. We often end up having to reconstruct feature by feature. The product is admittedly an abstraction and thus not “pronounceable,” and most modern practitioners eschew delving into allophony even where it might be possible. In practice most linguists seem to have quite a bit of faith in their constructs and would be willing to vouch, at least informally, for their phonetic manifestation(s). Obviously this cannot always be true, though, and the Proto-Siouan **r*/**R* distinction is a case in point. The phonetic feature by which these phonemes differed is unknown, so in this instance, even among linguists who “hug the phonetic ground,” **R* can only be a cover symbol for a divergent correspondence set. It is reconstructed the same as **r* except for one feature, but that one feature (possibly assimilated from an adjacent consonant or glide, since disappeared) remains phonetically elusive.

5.10 *Distributional statistics and problems in reconstruction*

Part of tying up loose ends in comparative reconstruction involves looking closely at the language one has reconstructed for hints about older changes and deeper alternations. We have seen that we must reconstruct an aspirated and a plain series of stops in Proto-Siouan. After reconstructing about a thousand lexemes an unexpected pattern emerges, however. Virtually all of the pre-aspirated stops reconstructed fall in accented syllables in the proto-language. Pre-aspiration apparently did not occur in unaccented syllables. Plain stops, on the other hand, do appear in Proto-Siouan accented syllables but only a small percentage of the time, perhaps in only about 10 or 15 percent of such stop consonant reconstructions. Words with plain stops in accented syllables include some very basic items, however: “four” and “make marks” in our small sample alone.

What should comparativists make of such distributional skewing? Most Siouanists believe it suggests that in pre-Proto-Siouan there was most likely an aspiration rule: $CV' > hCV'$ (where C was any stop). This cannot be proved conclusively, however, because it is not supported by alternations. Siouan languages utilize prefixes in inflection, and since affixation generally causes accent to move to the left as prefixes are added, we would expect aspirated and unaspirated stops in root morphemes to alternate in paradigms. But they do not.²¹ It seems likely that the putative pre-Proto-Siouan aspiration rule operated at one time, but then ceased to function actively in the language, leaving numerous roots with (pre-)aspirates frozen in place. This would have to have involved the analogical extension of the aspirated allomorphs (of verbs especially) to all contexts. The distantly related Catawba language offers no help. Catawba lacked any trace of aspiration. The comparative method is at an impasse here, as is internal reconstruction (because alternations are wanting). Only the distributional pattern of Proto-Siouan aspirates tells us that something is amiss. So in this case also, strict application of the comparative method leaves an unsatisfying residue.

6 Semantic Reconstruction

Lexical reconstruction of course involves more than just phonology; it must also involve semantics. And if the reflexes of a proto-morpheme or lexeme are semantically diverse, reconstruction can be quite difficult. In some instances the only solution is to reconstruct a meaning vague enough to encompass all the descendant forms or to reconstruct polysemy. In other cases it is sometimes possible to appeal to other links in a greater lexical system or semantic domain. Kinship systems (like systems of inflectional affixes: see below) often lend themselves to a kind of semantic componential analysis which may produce "pigeonholes" that aid semantic reconstruction. In other cases, known or inferable history may aid reconstruction. In the Siouan cognate set labeled 'throw' (table 1.2), the semantics of the descendant forms is more complex than my label suggested. The actually attested meanings of the reflexes in the individual languages are as follows: Crow and Mandan 'throw'; Dakotan, Ioway-Otoe, Omaha, Kansa, Osage, Quapaw 'shoot'; Biloxi 'hit, shoot at'; Tutelo 'shoot.'

In modern times, in the (vast majority of the) languages in which this term is translated 'shoot,' this verb has normally meant 'shoot with a firearm,' but in earlier times, of course, it meant 'shoot with an arrow.' Here, archeology becomes the handmaiden of linguistics. We know, thanks to a great deal of work by North American archeologists, that the bow and arrow appear in sites in the Illinois Country and adjacent areas west of the Mississippi River only in about the sixth century AD, long after Proto-Siouan had split into its major subgroups. Before that there were no bows in Siouan-speaking areas

and people hunted using atlatl darts propelled by throwing sticks. Knowing this, it is a simple matter to reconstruct the semantic progression: earlier 'throw,' originally applied to atlatls, became later 'shoot,' applied to bows and finally to guns. 'Throw,' attested only at the northwest corner of Siouan-speaking territory, virtually has to be the older meaning. Semantic reconstruction most often must be done on a word-by-word basis.

7 Morphological Reconstruction

In morphology, internal reconstruction deals with the comparison of allomorphs, and the comparative method should ordinarily not have to deal with allomorphy. Comparative reconstruction must then rely pretty strictly on the comparison of cognate morphemes. The requirement that comparative reconstruction of common affixal morphology be based on established sound correspondences is pretty much taken for granted, although there have been attempts to reconstruct grammatical categories from the comparison of analogs rather than cognates. This would never be considered in lexical reconstruction, however, where comparison of French *maison* with Spanish, Portuguese, Italian *casa* would be unthinkable. Some have found such comparisons more tempting in morphology where morphotactics (fixed common position in templatic inflectional morphology) may offer limited support for such reconstruction. For example, in the Mississippi Valley Siouan subgroup there is a pluralizing morpheme, **-api*, that occurs as the first suffix with verbs (aspect and mood morphology follows this affix). In the related Ohio Valley Siouan subgroup (Biloxi, Ofo, and Tutelo) the analog (not cognate) of *-api* is *-tu* 'pl.,' and it fills exactly the same post-verbal slot in the template. Is morphological pluralization reconstructible for Proto-Siouan verbs? Most would say not, because the morphemes in the recognized subgroups are not cognate, but it brings up the question of whether or not morphotactics alone may contribute at all to the notion of cognacy or of category reconstructibility.

To generalize these observations, comparison and reconstruction of empty templates are not generally accepted as legitimate. If the morphemic contents of the templates are properly cognate, then reconstruction of the morphology along with its positional restrictions becomes possible. Otherwise a much better understanding of the reasons for lack of morpheme cognacy is necessary before positional reconstruction can proceed.

The comparative method per se does not really provide for morphological reconstruction as distinct from phonological reconstruction. As Lass (1997: 248) puts it, "When 'standard' comparative reconstruction is carried out in morphological domains, it is (if done strictly) only projecting paradigmatic segmental correspondences to the syntagmatic plane." However, "morphs expound categories . . . and genuinely morphological change takes place at the category level." Comparison of morphological categories and paradigms can

create a matrix with cells (pigeonholes) for reconstructed members. This often provides help to the linguist, who then knows roughly what to expect in the way of inventories. If the material in expected/established cells in an inflectional matrix fails to correspond phonologically, however, recovery of the proto-morpheme can be problematic.

Loss of entire grammatical categories can lead to inability to reconstruct large parts of the system. In the morphology of the Romance languages, for example, less than half of Classical Latin inflectional endings are reconstructible. Much of the problem is due to early loss of the Latin passive subsystem, nothing of which is really preserved in the modern languages, and the loss of most (not all) nominal case marking. Almost all of the Latin future tense morphology has also been lost without a trace. Within the active voice, non-future morphology, however, most of the present, imperfect, and perfect categories along with most of the person-number marking system is reasonably well preserved in both indicative and subjunctive moods, and is reconstructible. This may serve to give some hint as to how much morphology might be hoped for in a reconstruction with an approximate 2500-year time depth. Koch (1996: 218–63) surveys morphological change and reconstruction with detailed discussion of methodology for recovering particular kinds of information.

8 Reconstruction at the Morphology–Syntax Interface

Case is a system for marking dependent elements for the type of relationship they bear to their heads. Nominal case is therefore most frequently a characteristic of dependent-marking languages, but pronominal case is much more widespread than nominal case. In many if not most language families, pronominals are fairly easily reconstructed. They occur in paradigms, and distinct cases often may partially share phonological shape. Person, number, and other features found in one pronominal paradigm (e.g., nominative) will normally be found in the others (e.g., accusative, dative, etc.), and reconstruction is thus facilitated. But syntactic and semantic alignment of such systems can present different kinds of reconstructive problems. In Indo-European there are numerous disagreements among languages and subgroups as to which nominal case is governed by particular adpositions. In the Siouan languages there is a split between the pronominal set used as subjects of active verbs (both transitive and intransitive) and the set used as the subjects of stative verbs and transitive objects. Siouan languages thus show active–stative (sometimes called split intransitive) case alignment, and the reconstruction of the borderline between these two categories poses interesting tests for the comparative method. The pronominal prefixes themselves have undergone phonological and analogical changes that need not be discussed here, but otherwise their reconstruction is rather straightforward (table 1.6).

Table 1.6 The active–stative borderline in Siouan languages

Person	Active subjects	Stative subjects and objects
1st	*wa-	*wɨ- ~ wə-
2nd	*ya-	*yɨ-
3rd	∅	∅
Inclusive	*wɨk-	*wa-

Table 1.7 Simple adjectival predicates in Siouan languages

English	Kansa	Osage	Quapaw	Ponca	Dakota	Crow
'be cold'	hníčče	hnícce	sní	usní	sní	alačiši
'be blue'	ttóho	htóho	ttó	ttú	thó	šúa
'be tall'	sčěje	sčéce	stétte	snéde	hąska	háčka

Stative verbs themselves appear to fall into about three subclasses: (i) a group that we may call adjectival predicates, which are consistently stative morphologically across the entire Siouan language family; (ii) positional verbs, which are consistently active morphologically across the family; (iii) verbs which are morphologically stative but semantically active. It is this last subclass of stative verbs that is the most interesting and that illustrates the problems faced in morphological reconstruction when Lass's (1997: 248) "genuinely morphological change takes place at the category level."²²

Most simple adjectival predicates, those translatable into English with "to be X" and including attributes, colors, etc., are regularly stative across Siouan. There are probably hundreds of these and the class is clearly reconstructible as almost entirely stative, and this includes instances, like 'be tall,' in which cognacy is not 100 percent. In other words, this large subclass seems semantically defined (table 1.7).

A small class of exceptions is also well defined and reconstructible, namely the positionals and an existential verb. Cognacy within this set is high, and these are all intransitive and morphologically active, though semantically stative (table 1.8).

But there are numerous additional intransitives that are semantically active but morphologically stative in at least several of the languages. They present an interesting problem in morphological reconstruction because case alignment is not consistent across Siouan. In table 1.9, I eschew particular forms and note only whether the verbs are cognate (C) or non-cognate (NC) and morphologically active (A) or stative (S).

Table 1.8 Exceptions to table 1.7

English	Kansa	Osage	Quapaw	Ponca	Dakota	Crow
'be sitting'	yikhé	ḍikšé	nīkhé	nīkhé	yāká	dahkú
'standing'	kháhe	tháhe	tháhe	tháhe	(há)	á:hku
'lying'	žá	žákšé	žá	žá	yúká	ba:čí
'be alive'	ní	ní	ní	ní	ni	ilí

Table 1.9 Verb cognacy and activity in Siouan languages

English	Kansa	Osage	Quapaw	Ponca	Dakota	Crow
'fall down'	C/S	C/S	C/S	C/S	C/S	NC/S
'ache, hurt'	C/S	C/S	C/S	C/S	NC/S	C/S?
'recover'	C/S	C/S	NC/S	C/S	C/S	NC/S
'perspire'	C/S	C/S	C/S	NC/S	NC/S	NC/S
'tell lies'	C/S	C/S	C/A	NC/A	NC/S	NC/S
'die'	C/A	C/A	C/S	C/A	C/S	C/S
'belch'	C/A	C/A	NC/A	NC/S	NC/S	NC/A
'forget'	NC/S	NC/A	C/A	NC/A	C/A	NC/A
'cough'	C/A	C/A	C/A	C/A	C/A	NC/A

Stativity decreases descending the chart, but note that there seems to be relatively little correlation with cognacy of the verb roots. The distribution of the data here, along with a general lack of cognacy of the Crow forms, suggests that a morphological shift from active to stative marking of experiencer subjects has been an ongoing process within Siouan.²³ In summary, it seems probable that:

- i Adjectival predicates were consistently stative in Proto-Siouan. The only subclass of exceptions were the positionals and 'be alive.'
- ii A very few semantically active verbs may have been marked statively in Proto-Siouan. These include 'fall down, ache' and perhaps a few others with experiencer subjects.
- iii The presence of the few experiencer statives created a new model that has served to extend the category to different degrees and with different verb roots in all of the modern Siouan languages. In some cases innovations can be traced to subgroup nodes, but in many instances the switch in case alignment for a particular verb affects only single languages in diverse subgroups. While most verbs seem to have gone from active to stative, in

a few instances there is evidence of passage from stative to active.²⁴ Our conclusions here are rather general: specifying precisely which semantically active verbs had stative morphology in Proto-Siouan is difficult because of lack of cognacy (especially of the Crow forms) within the group. Nevertheless, comparative linguistics give us at least some perspective on this ongoing change.

9 Syntactic Reconstruction

If comparanda can sometimes be controversial in morphology, they are very much more so in syntax. Ordinarily the notion of cognacy implies structural entities that correspond regularly in both form and meaning. If either is wanting, cognacy is not achieved. In syntax there are basic problems in both domains. First of all, it is difficult to know just what to consider formal equivalents when comparing syntactic structures (see discussion in Watkins 1976). In phonology one compares phonemes (by some definition), in morphology one compares morphemes. What is the comparable unit in syntax?²⁵ Second, it should be obvious that the semantic relatedness criterion is simply problematic in many areas of syntax.

In most modern linguistic theories, syntactic structures are generated, not stored in memory. The structures themselves, then, cannot be comparanda in the same sense as words, phonemes, and morphemes are. "Sentences are formed, not learned; morphemes and simple lexemes are learned, not formed" (Winter 1984: 622–3).

Thus the comparative method per se has often been at an impasse in the area of syntactic reconstruction because of a lack of availability of anything like real cognates. Instead, basic typological agreements have sometimes been examined with a view to projecting their existence and accompanying congruities into the past. Central to this enterprise is the *cross-category harmony principle*, according to which head and dependent dyads tend to be arranged in either consistently head-first or consistently head-last order cross-linguistically.²⁶ As a general reconstructive methodology for syntax this technique cannot be judged a success, since syntactic change can affect a language one dyad at a time, and has often done just that, leaving a language or family full of cross-category disharmonies.

In the Siouan language family, virtually all members are (S)OV (dependent-head) in basic word order, and dependents normally precede their heads at other levels (noun-adposition, adverb-verb, verb-auxiliary, demonstrative-noun, genitive-noun, etc.). Adjectives follow their nouns in Siouan languages, but, as we have seen, Siouan adjectives are members of the subclass of stative verbs and may best be considered heads of their respective constructions. As can be seen below, a purely typological approach would seem to lead us to the conclusion that Proto-Siouan was an SOV language. This would probably be

historically correct, but that is really because all known Siouan languages have SOV word order.²⁷ If they did not, it does not seem likely that typology would give us the answers we need. Nor can it answer important questions about NP and clause marking in Proto-Siouan:²⁸

- Crow: iisáakši-m háčkee-š úuxa-m dappeé-k
 y.-man-HEAD tall-DEF deer-a kill-DECLAR
 "The tall young man killed a deer."
- Lakota: koškálaka háske ki (he) thá wə kté
 young.man tall the DEM deer a kill
 "The tall young man killed a deer."
- Ponca: núžiga snéde akha ttáxti wī tʔéða biamá
 boy tall SUBJ deer a die-CAUS they.say
 "The tall boy killed a deer."
- Biloxi: sītó tudé ta o téye
 boy tall deer shoot die-CAUS
 "The tall boy shot and killed a deer."

These sentences, most translations elicited by linguists, show closely parallel patterns that are congruent with a Proto-Siouan SOV word order. 'Kill' is a compound of 'die' plus a causative auxiliary in Ponca and Biloxi but is a lexical verb in Lakota, so the proto-language morphology is unclear there. Crow, Lakota, and Ponca require definite articles with the subject, but Biloxi does not, and the articles are not cognate across the other languages, so the origins of that morphology remain unclear also. Case marking for nouns, to the extent that it existed, does not seem to be reconstructible:

- Crow: iisáakšee-š áaše kuss-basáa-k
 y.-man-DEF river toward-run-DECLAR
 "The young man is running to the river."
- Lakota: koškálaka ki wakpála ektá íyake
 young.man the river toward run
 "The young man is running to the river."
- Omaha: núžiga akha wathíška khe ttáđiša tʔađi biamá
 boy SUBJ river the.lying toward run they.say
 "The boy ran toward the river."
- Biloxi: sītó ayixya məkiwaya ʔaḥi
 boy bayou toward run
 "The boy ran toward the bayou."

Intransitive syntax is entirely SV with postpositions, but the postpositions themselves are not cognate among the subgroups. Still, the existence of postpositions in the proto-language seems very likely. As with transitive sentences, suffixal and enclitic morphology is not cognate and therefore not reconstructible:

- Crow: iisáakši-m úuxee-š ak-dappée-š háčka-k
 y..man-HEAD deer-DEF REL-kill-DEF tall-DECLAR
 "The young man who killed the deer is tall."
- Lakota: koškálaka wə thá ki kté ki he ḥaske
 young.man a deer the kill the DEM tall
 "The young man who killed the deer is tall."
- Omaha: núžiga akha ttáxti tʔéde akha snéde abiamá
 boy the.SUBJ deer die-CAUS the tall they.say
 "The boy who killed the deer is tall."
- Biloxi: itá té-ye yā sító tudé
 deer die-caus. REL boy tall
 "The boy who killed the deer is tall."

The relative clause, *who killed the deer*, is preposed to its head in Biloxi, and that is the order expected in an SOV language. In the other languages the relative clause is postposed to its head, possibly in accordance with what typologists call the *heavy constituent principle*, by which longer, more cumbersome dependent elements are often postposed even if head-last order is expected. Nevertheless, the syntactic disagreement renders it very difficult to reconstruct a unique order for relative clauses in the proto-language. Articles and/or demonstratives (Crow -š, Lakota *ki he*, Omaha -akha, and Biloxi *yā*) serve as relativizers in all the languages, but none is cognate from one subgroup to the next, so no Proto-Siouan relativizer can be reconstructed.

Since this syntactically homogeneous language family contains 16 languages in four major subgroups, spread geographically over thousands of square miles, most Siouanists consider it likely that an SOV word order reconstruction is accurate for Proto-Siouan, probably at a time depth of over three thousand years. And Proto-Siouan probably had most of the other characteristics of OV languages. But note that this has been established by comparing entities that correspond primarily in form and only roughly in meaning. Definitizing and relativizing morphology is not cognate, nor is quite a bit of the substantive vocabulary. The comparative method requires both formal and semantic correspondence. Thus far, examining analogous (not cognate) sentence types and noting typological homogeneity, we have been able to reconstruct only the very broadest outlines of Siouan syntax.

As language families become syntactically less homogeneous, the necessity of using something much closer to the real comparative method clearly asserts itself. Indo-European (along with many other language families) lacks the typological homogeneity that Siouan presented: there are Indo-European subgroups with SOV, SVO, and VSO word order. And since the overall directionality of prehistoric syntactic change cannot be established simply by looking at a synchronic sample (like the Homeric poems or the Vedas) or at historical directionality over just the past two or three millennia, Watkins (1976) adopts the requirement that one compare sentences with analogous formal structure, but he adds the further requirement that they mean the same

thing. Just as we require that cognate words show equations of both form and meaning, he posits a strong requirement that comparable sentences also show equations in both form and meaning. In effect he reconstructs from *cognate sentences* in about as strict a sense as one could imagine in syntax.

And his cognate sentences tend to be from among the small set of exceptions to the general rule that “sentences are formed not learned.” Some sentences, of course, are indeed learned rather than generated and are, thus, analogous to simple lexical items. These are mostly formulae of one kind or another. They may include special ways in which people or professions talk about particular subject matter (Watkins selects ancient sports events), proverbs, folk narratives, perhaps poetry (with the obvious caveat that versification often affects syntax), formal legal documents, and perhaps a few other culturally defined styles.

Like Watkins, practitioners of the typological method have also sought expressions that show archaic syntax in order to make use of the cross-category harmony principle. Among the additional sources of relic syntax that have been suggested are comparison of inequality, adpositions, numerals in the teens, pronominal patterns, and certain derivational formations (Lehmann 1976: 172ff).²⁹

Both derivational and inflectional morphology are often thought to be sources of archaic syntactic structures. Givón’s (1971: 413) claim that “Today’s morphology is yesterday’s syntax” typifies this view. The idea is that processes of grammaticalization create clitics and then affixes that attach to stems in the order in which they originally occurred as independent words. Thus frozen syntactic constructions are preserved and can be analyzed for ancient head-dependent constructions and congruities, etc. This seems to work well in certain instances; for example, future tense marking in Indo-European, Latin, and subsequently Romance. But in other cases, notably involving compounds and person-number clitics or affixes, it fails. Givón mentions that modern Spanish clitic object pronouns preserve the OV order of early Latin, but a glance at Old Spanish texts shows copious examples of just these pronouns *following* conjugated verbs in the Spanish of the eleventh century.³⁰ Comrie (1980) finds similar problems in Mongolian. The difficulties seem to arise during the cliticization period, when there are obviously competing principles for placement (Wackernagel’s Law phenomena, unidirectionality of permitted affixation in some languages, e.g., suffixation in Turkic, etc.) that can ultimately produce ahistorical orderings. Nevertheless, morphology may be very helpful in syntactic reconstruction provided it is used judiciously and not too closely coupled to inferences derived from the cross-category harmony principle.

Harris and Campbell (1995: 355) and Harrison (this volume) discuss numerous problems associated with the notion that the order of elements within *compounds* routinely recapitulates earlier head-dependent orders. They believe compounds, as a source of information about older word orders, should be generally ruled out.

Intermediate between comparison of the arrangements of the head-dependent dyads favored by some typologists and Watkins’s formulaic

“cognate sentences” are the sources of syntactic correspondences suggested by Harris and Campbell (1995: 350ff). While urging caution, they suggest translations, both literary and elicited (sometimes from bilinguals), as possible sources of generated, cognate syntactic structures. This is approximately what I have done in the Siouan sentences discussed above. While not providing “descendant” sister clauses and phrases (like formulaic utterances), such sources can perhaps provide comparable results of “sister rules.”

Lehmann (1976: 172) emphasizes some of the difficulties in dealing with translations, pointing out that translations of the scriptures were used in the study of languages like Gothic, Armenian, and Old Church Slavic, but that influence from the source language, Greek in these instances, has been found to be troublesome. Obviously calques are a major problem encountered using translations, but perhaps it is one that can be overcome. Translations would certainly provide comparable material between/among closely related languages. One can easily imagine obtaining nearly identical sentences eliciting the same utterance in, say, Spanish and Italian or Slovene and Serbian. This may be of interest to linguists operating within small language families of relatively shallow time depth, but eliciting translations of the same sentence in Spanish and Irish would yield more syntactic variables than could easily be dealt with. Clearly syntax presents problems that are much more vexing than those usually faced by comparative phonologists.

The primary comparanda of comparative syntax are still being debated, but we should not be surprised to find that different language families and different historical circumstances place different demands on the comparativist. The relative uniformity of the Siouan language family (with its relatively shallow time depth), coupled with the relatively greater syntactic homogeneity found in SOV languages generally, makes comparative syntax there relatively straightforward. In Indo-European, however, with much less syntactic homogeneity to work from (and considerably greater time depth), Watkins (1976) sees a necessity for greater stringency in selecting comparanda. As difficulty increases, he properly tightens his requirements. Some linguists loosen their methodology when faced with difficult problems, voicing the complaint that by sticking to old-fashioned standards one might never make new discoveries. This is basically the position that *necessity confers legitimacy*. But in science necessity does not confer legitimacy.

9.1 *The problem of naturalness in syntax*

As we have seen, one of the factors that makes phonological reconstruction possible is our fairly thorough understanding of the directionality of sound change in particular environments. We expect sound change to be phonetically natural, at least at the outset, and we expect it often to affect entire natural classes. This frequently makes reconstruction a matter of working backward along well-established trajectories. Our understanding of naturalness in syntactic

change is far less well developed (see chapters by Harris, Lightfoot, and Pintzuk in this volume, as well as those on grammaticalization by Bybee, Fortson, Heine, Hock, Joseph, Mithun, and Traugott). And, in fact, there is little reason to believe that we will ever reach comparable levels of understanding in syntax, because phonetic change is physiologically shaped and constrained by the configuration of the vocal organs and by perception, while syntactic change is not.

The best bets for syntactic reconstruction at this time would seem to be the use of relic constructions, if such can be identified. Working backward along well-established grammaticalization clines and/or syntactic change trajectories may be helpful, again, if sufficient numbers of these can be identified with certainty. Harris and Campbell (1995: 361ff), for example, identify postpositions → case suffixes, modal auxiliaries → modal suffixes, passive → ergative, ablative → partitive as “one-way” morphosyntactic changes. In some instances it may also be possible to take advantage of certain, unambiguous cross-category harmonies. Harris and Campbell concentrate on restricted parts of the word order typology, especially the few apparently conservative characteristics that are consistently SOV-related. These include (pp. 364–6) relative clauses preposed to their heads, and the order Standard–Marker–Adjective in comparisons of inequality. They first establish syntactically corresponding patterns so that reconstruction becomes a matter of determining which pattern is older. Then they concentrate on a single strong argument of the sort mentioned just above.

10 Proto-Language as a Repository for Regularities as Opposed to Irregularities

Most linguists prefer to reconstruct only those features that can be shown to have been systematic in the proto-language. Returning to the Siouan cognate set translated “throw” (table 1.2), we see that no Winnebago cognate was given. In fact there is a Winnebago word, *gu:č*, that closely resembles the cognates in the other languages. Except for the fact that the form begins with *g-* instead of *k-*, it is precisely what we would expect in this set. Most comparativists would judge this exception to be too small to justify reconstructing anything but **hku:te* for the set. Since there are no other examples of this correspondence, and we lack parallel cases with *p/b* or *t/d*, we assume that some interesting but irrecoverable development occurred in Winnebago alone and do not reconstruct a third stop such as **gh* or the like because of this set. We assume the anomaly is internal to Winnebago and not that Winnebago retains something lost everywhere else. The difference between our treatment of Winnebago ‘throw (= shoot)’ and the problem of the two rhotic phonemes, **r* and **R*, is one of degree, however. There are too many instances of **R* without an explanatory environment for us to ignore them, even though we suspect there may have been only a single **r*, with **R* arising in certain kinds

of clusters. We make a conscious decision to exclude a single Winnebago form that contains a unique sound correspondence, preferring to reconstruct only what is systematic.

Of course inconvenient residue can be very important and should never be dismissed out of hand or simply hidden away. The celebrated case of Verner's Law illustrates clearly the fact that a closer examination of residual cases that seem to be exceptional can lead to important discoveries that serve not only to explain the data of particular languages or language families but also to reinforce our understanding of basic sound change regularity.

Comparativists are sometimes accused of reconstructing completely uniform proto-languages – agglutinating languages without morphophonemic alternations, without variation, and without irregularities. This is simply not a serious criticism; the shape of our reconstructions is most often a consequence of our preference for regarding proto-languages as repositories for systematicity, not idiosyncrasy, but it is also a consequence of insisting on pushing internal reconstruction as far as possible.³¹ This does not mean that we believe in the perfect uniformity of proto-languages. Every serious comparativist understands that, doubtless, there were older irregularities, morphophonemic alternations, and dialects; we simply reconstruct as far as we can and no farther. Proof of older fusion, variability, or idiosyncrasy is simply beyond our reach at some point.

11 Temporal Limits on the Comparative Method

The above discussion does raise an interesting question. Both phonological and analogical change erode languages constantly. Over time, reanalysis and extension can alter the most basic syntactic patterns, and an SOV language may take on an entirely different word order and set of accompanying cross-category harmonies. Lexicostatistics has shown that basic cognates shared by pairs of languages undergo attrition at a relatively common rate.³² These factors, taken together, will tend over time to render our methods of reconstruction less effectual and finally ineffectual. If cognate attrition takes place at somewhere in the vicinity of 20 percent per millennium, and we depend on cognates for lexical and phonological reconstruction, the comparative method will be useless for recovering information within a family of languages in a period of something less than 20,000 years. Adding other phonological and morphosyntactic change to cognate loss, we may count on significantly less than this amount of time. Just how much is a matter of debate. There is no consensus on just what the temporal limits really are, but well-studied language families such as Indo-European, Uralic, and Afro-Asiatic suggest that our methods may be valid to a time depth of at least around 10,000 years.³³

The productivity of the method simply trails off as availability of comparanda declines over time. At some point linguistic relationships may yet

be recognizable, because of retained idiosyncratic morphological patterns of the sort that Meillet (1925) delighted in, or multidimensional paradigmaticity of the sort discussed by Nichols (1996), but the ability actually to reconstruct may be lacking. We find this situation to a degree in Algonquian-Ritwan (Goddard 1991), where there is strong paradigmatic evidence for genetic relationship and a certain number of clear lexical cognates but little possibility of fleshing out details of the proto-language.

Overall, however, the comparative method is arguably the most stable and successful of all linguistic methodologies. It has remained essentially unchanged for over a century. This is not because comparative linguistics has faded from view or is less important than it was a hundred years ago. Quite the opposite: its principles have withstood the tests of time and the onslaughts of its critics. The reconstruction of Proto-Indo-European stands as a monument to the very best of nineteenth-century intellectual achievement. In the twentieth century, the comparative method was shown by Bloomfield and others to be equally applicable to non-written languages in diverse parts of the world. Much linguistic reconstruction remains to be done, and if we maintain the integrity of the comparative method, we will be able to do it.

NOTES

- 1 Here I refer only to reconstruction. Grammatical correspondences have often been the feature that first established genetic relationships beyond doubt. For example, Sir William Jones's oft-quoted statement about Sanskrit, Greek, and Latin refers to the systematic correspondences in their grammars.
- 2 I do not mean to imply that archeology cannot contribute outside of areas of material culture, only that linguistics is a complementary and often superior tool in the non-physical domains. I have also ignored here the increasingly important contributions of physical anthropology in the study of prehistoric movements and relatedness of peoples, determination of their diet, etc. A synthesis of linguistic, archeological and physical anthropological information is ultimately necessary.
- 3 See also Hopper and Traugott (1993) and chapters by Bybee, Fortson, Heine, Hock, Joseph, Mithun, and Traugott in this volume.
- 4 Since, with imitative vocabulary, there is never a necessary historical connection between the onomatopoe at one stage and the ostensibly "same" one at a later stage. Onomatopoes can be reinvented at any time and by any generation.
- 5 A detailed discussion of sound change is found elsewhere in this volume (see the chapters by Guy, Hale, Janda, Kiparsky, and Ohala). There are a dozen different definitions of the term *sound change*, however, so I feel it is important to include a brief discussion of the phenomenon here. Much of the ink that has been spilled debating the nature of sound change could have been saved simply by not applying one linguist's definition to another

- linguist's work, especially if they were not contemporaries.
- 6 Schuchardt (1885) in fact claimed that most of what the Neogrammarians saw as sound change was "rein lautliche Analogie," purely phonetic analogy, which affected single words or environments at a time (Keith Percival, pers. comm.).
 - 7 After more than thirty years of redefining dialect borrowing as "sound change" (Labov 1963, esp. 1965: 272), Labov (1994: 440ff), citing Hoenigswald (1978), acknowledges this truth about the Neogrammarian position. See also Lass (1997: 134) for discussion of this issue. A particularly good example of "straw man" discussion of the Neogrammarian position is Postal (1968: 231–60).
 - 8 Hoenigswald (1960: 73) went so far as to say that "viewing sound change as a special case of (total) dialect borrowing . . . does no . . . violence to (the) facts; it accounts both for the suddenness of phonemic change and for its regularity and requires few particular assumptions beyond that of the existence of subphonemic variation in the speech community – an assumption in perfect keeping with observed data." This view characterizes the better-elaborated position taken later by Labov (1963, 1965). Labov (1994: 470f, 541ff) clarifies his earlier position and tries to sort out contexts in which regularity operates according to Neogrammarian principles and those in which lexical diffusion is more likely to be found. Labov (1994) is probably the best and most complete discussion of the problems (and pseudo-problems) to date.
 - 9 For example, Malcolm Ross, in lectures given at the 1997 LSA Linguistic Institute, divides much of Austronesian into (i) those languages within a subgroup whose speakers migrated (generally eastward) across the Pacific and can be accommodated fairly easily in a family tree and (ii) what he calls the "stay-at-home languages" whose speakers remained in close contact with each other, forming complex interrelationships that are very difficult to sort out.
 - 10 See Fox (1995: 122–36) for a history and discussion of the pros and cons of the allegedly polar views.
 - 11 Ross (1996: 181ff) presents particularly good examples of these sorts of problems. Although he confines his discussion mostly to Austronesian languages of Papua New Guinea, the model and developments he postulates for PNG are probably not far from what happened in Europe and much of the rest of the world as today's national languages were forming.
 - 12 See also Labov (1994), Fox (1995: 195), Lass (1997), Janda (2001), and the introduction to this volume for further discussion.
 - 13 Discovery and/or confirmation of relatedness is considered an integral part of the comparative method by some linguists. The problem of establishing genetic relationship has become important enough in recent years to require a separate chapter, however. See Campbell's excellent discussion in this volume.
 - 14 It is probably not an accident that the study of lectal variability was perceived as being increasingly important as phonology became more abstract. Until the early to mid-1960s dialect data were often subject to analysis and presentation in terms of surface phonemes. This had the effect of reducing the visibility of variation and probably

- of de-emphasizing the social dimension that it presents. It is reasonable to phonemicize comparative data, however. Here it may be looked upon as a form of low-level internal reconstruction.
- 15 Lass (1997: 250n.) makes this point nicely, but more in relation to morphosyntactic reconstruction (where it is just as valid).
- 16 I am grateful to Eric Hamp for discussion of the issue of abstraction in choosing comparanda. The importance of the surface phoneme in historical linguistics was recognized fairly early in the generative period by Schane (1971).
- 17 Siouan languages are native North American languages spoken originally in a broad band extending from the foothills of the Rockies in Canada southeastward to the mouth of the Arkansas River with several outliers as far east and south as Mississippi, Alabama, and Virginia. There are about sixteen Siouan languages documented to various degrees. About ten are still spoken by at least a few persons, about five of these by more than a few hundred. At least six are extinct. These cognate sets are taken from Carter et al. (forthcoming) and some of the discussion recapitulates Rankin et al. (1998). Interpretation of these data is my own.
- 18 It is important to note that the correspondence sets that comparativists work with are often the "compressed" result of many individual changes.
- 19 It is worth mentioning here that Allen (1994: 639) recommends also considering what he calls *subfamily typology* when reconstructing. He is referring to what amounts to particular, often recurring, phonetic "drifts" present in individual families or subgroups that may not be as common outside that group. This might include such persistent processes as palatalization in Slavic or nasal spread in Siouan, for example. Lass (1975) referred to such drifts as "family universals," a term with implications broader than what I wish to convey here.
- 20 Some Siouanists have preferred to reconstruct **l* for this set. Phonetically there is probably little reason to favor one over the other. Several languages have shifted from rhotic to lateral resonants during the historical period, however, so **r* is perhaps the better choice. I would like to thank Dick Carter, Wes Jones, John Koontz, and David Rood for their many useful observations on Siouan reconstruction.
- 21 A possible exception may be Ofo. In the transcription of John R. Swanton (1912), Ofo aspirates seem to alternate, with aspiration often disappearing in unaccented syllables. Swanton only recorded about six hundred words of Ofo, and little was included in the way of verb paradigms that would tell us whether the alternations were systematic. And even if some such alternation is found in Ofo, it may represent an innovation rather than a retention, since even the most closely related languages lack any sign of an aspiration alternation.
- 22 I wish to thank Fr. Randolph Graczyk, John Koontz, and David Rood for their protracted discussion of these matters with me via electronic mail. They have provided numerous insights, although any errors are my own. Kathy Shea and Parrish Williams provided fresh Ponca data, Randy Graczyk provided Crow data, Quapaw data are from the James Owen Dorsey collection at the National Anthropological Archives of the

- Smithsonian Institution, Osage data are from Carolyn Quintero (pers. comm.), and Quintero (1998), Kansa data are from †Maude Rowe. This work has also benefited from exchanges with Regina Pustet about her statistical analyses of this split in Siouan.
- 23 Other verbs in my sample with mixed active/stative marking across Siouan include “get lost, stumble, lack, tremble, have a cramp, possess, arise, itch, pant, suffer, bleed, get dizzy, shrivel, swell up, tumble, lose, bow head, snore, twitch, stagger, open eyes, remember, have a chill.”
- 24 This treatment avoids discussion of additional, often phonological, mechanisms affecting this change. In Crow, for example, only the pronominal prefix vowel serves to differentiate actives from statives, and these vowels are often assimilated in vowel-initial verb stems, leaving the distinction only in 1st pl. forms (Graczyk, pers. comm.). In Biloxi, a language not dealt with in this section, the active/stative distinction is only maintained in the 2nd person and is phonologically difficult even there. So a number of linguistic factors contribute to some of these category changes. In Dakotan, Omaha-Ponca, Kansa, and Osage, conditioning does not seem to involve much phonology, however.
- 25 The notion of the *tagmeme* has surfaced from time to time, but there is little if any agreement about its nature among syntacticians. The putative existence of such a unit should, however, serve to underscore the theory-dependent nature of some of the arguments about comparative syntax. Lehmann (1976: 171) emphasizes that there is no agreement on units or their interrelationships at the syntactic level.
- 26 There is an entire literature on this subject. For a recent survey and discussion of the consequences of using such methodology, see Harris and Campbell (1995: 140, 195ff).
- 27 Actually, the Dhegihan subgroup of Siouan shows OVS word order rather often, perhaps 10–12 percent of the time (Catherine Rudin, pers. comm.).
- 28 Fr. Randolph Graczyk and David S. Rood provided me with Crow and Lakota data respectively and helped clarify my understanding of them. Ponca examples are composed from Dorsey (1890), and the author’s own Omaha and Kansa language notes were also consulted. These examples may be taken as representative of what one finds in the larger text collections. The Biloxi examples are composites, with certain vocabulary replaced, of more than one sentence from among those found in Dorsey and Swanton (1912). Such composition is not a technique I would recommend in actual reconstruction, but Biloxi is long extinct, and it seemed advisable to use examples containing approximately the same lexemes.
- 29 Comparing numerals in the teens in language families such as Romance or Siouan, one is hard put to perceive a clearly archaic pattern. And there are competing patterns among other Indo-European subgroups also. Adpositions in Latin were preposed even though the older language tended strongly to SOV word order.
- 30 There are dozens of examples of this *finite verb+object pronoun* order in just the first couple of hundred lines of the *Poema de mio Çid*.
- 31 Performing internal reconstruction on a reconstructed proto-language

yields a result that may, of course, represent a collapsing of many centuries of development.

- 32 One need not embrace the tenets of glottochronology (this writer does not) to accept lexicostatistical demonstrations of fairly regular attrition. It has been shown that some languages are indeed more

conservative in retaining basic cognates, while others, of course, have undergone complete relexification. Whatever the rate, loss is continuous.

- 33 Nichols (1992a: 2–3), for example, posits a practical limit on the comparative method of about eight thousand years or a bit more.

2 On the Limits of the Comparative Method

S. P. HARRISON

In this chapter, I explore the limits of the comparative method as a tool in comparative historical linguistics.¹ Let me be quite clear about one thing from the outset: for me, the comparative method is the *sine qua non* of linguistic pre-history. I believe that the comparative method is the only tool available to us for determining genetic relatedness amongst languages, in the absence of written records. I believe that prior “successful” application of the comparative method is a prerequisite to any attempt at grammatical comparison and reconstruction.

But the comparative method has limitations, determined by the very properties of the method that make it work:

- i *It has relative temporal limitations.* The more changes related languages have undergone (in general, a function of time), the less likely the method is to be able to determine relatedness.
- ii *It has sociohistorical limitations.* Certain historical situations can have linguistic consequences that vitiate the comparative method.
- iii *It has linguistic domain limitations.* Only certain sorts of linguistic objects can be usefully compared and reconstructed using the method.
- iv *It has limitations of “delicacy.”* Only genetic relationships up to a certain degree of precision or delicacy can be reliably determined using the method.

I discuss each of these types of limitation in turn below.

Disagreements and misunderstandings regarding what the comparative method can and cannot do are a continuing (and, some might say, distracting) leitmotif in comparative historical linguistics. The level of disagreement has often surprised me, and must be attributed to some level of disagreement regarding what the comparative method in historical linguistics actually involves, what its premises are, and what its recognized argument forms are. My first task, then, must be to outline what *I* think the method is.

In section 1, I outline what I see as the goals of comparative historical linguistics. In section 2, I describe how the comparative method serves to realize those goals. The limits and limitations of the comparative method are treated

in section 3. Sections 3.1 and 3.2 discuss the possibility of comparing and reconstructing grammar, both with and without the comparative method. Section 3.3 discusses two circumstances in which the comparative method may fail to recognize genetic relatedness. Section 3.4 is devoted to the unique problems posed by subgrouping. Section 4 considers briefly how the comparative historical linguist can survive the limitations on the comparative method.

1 The Goals of Comparative Historical Linguistics

Identifying the goals of comparative historical linguistics is not a particularly problematic exercise. They are essentially three in number:

- i to identify instances of genetic relatedness amongst languages;
- ii to explore the history of individual languages;
- iii to develop a theory of linguistic change.

Nor, of course, are these goals in practice independent. The identification of instances of genetic relatedness is likely to be a concomitant of the investigation of the histories of one or more related languages. The development of a theory of linguistic change is informed, one trusts, by investigation of the histories of individual languages and language families.

Prehistorians might be satisfied with (or, at least, most immediately interested in) results stemming from the first of these goals, and cultural historians with the second. “True” historical linguists view the third goal as the real prize, the ultimate aim of the exercise. That is certainly how I rank the goals. I want to know whether one can distinguish possible from impossible changes, or, at the very least, probable from improbable. I want to know whether or not there are any constraints on borrowing. I want to understand the engine of language change – how changes begin, and how they move through languages and linguistic communities.

The desiderata of a such a theory of language change were set out quite clearly over a quarter century ago in Weinreich et al. (1968). Some aspects of the research program they outlined have been elaborated in subsequent work. Labov and others have studied cases of language change in progress (cf., e.g., especially, Labov 1994 for discussion and extensive references). The regularity assumption (see below) has been put under scrutiny in their work, and in the work begun by Wang (1969; cf. also Wang 1977) on the so-called “lexical diffusion” of sound change. The notions “natural linguistic process” and “natural linguistic system” (and, derivatively, “natural linguistic change”) have been the focus of linguistic theory from the time Weinreich et al. (1968) appeared. More recently, scholars like Sarah Thomason have given detailed consideration to the limits of borrowing and diffusion.² But, we are still some distance away from a theory of language change.

2 The Place of the Comparative Method

A theory of the sort envisaged in the preceding section is one that, given some synchronic language state S , would tell us what immediate antecedent state(s) P_s^+ could/must have given rise to S . Such antecedent state sets for different languages could then be compared for “best fit,” in order to select amongst potential antecedent state candidates (if the theory supplies more than one) and to determine genetic relatedness. In the absence of such a theory,³ however, the comparative method has served the historical linguistic enterprise for well over the past hundred years or so, *because it acts as a stand-in for, or as a first approximation to, a theory of language change.*

The comparative method does at least part of the job of a hypothetical theory of change, but in the reverse order. The primary role of the comparative method is in developing and testing hypotheses regarding genetic relatedness. Its secondary, and subsequent, role (in what might be termed “realist” comparative linguistics) is in recovering antecedent language states through reconstruction.⁴

In order to demonstrate that the members of some set of distinct linguistic systems⁵ are or are not genetically related, one must demonstrate:

- i that there are similarities amongst the languages compared, and then
- ii that those similarities can *best* be explained (or can *only* be explained, depending on just how confidently one wants to present the results of the method) by assuming them to reflect properties inherited from a putative common ancestor.⁶

What permits us to make the move from the observations of cross-linguistic similarity in (i) to the conclusion (ii) that the languages in question are genetically related is an implication (rule of inference, or warrant) that might be stated informally as follows:

The major warrant for genetic inference

If two or more languages share a feature which is unlikely to have:

- i arisen independently in each of them by nature, or
- ii arisen independently in each of them by chance, or
- iii diffused amongst or been borrowed between them

then this feature must have arisen only once, when the languages were one and the same.⁷

A genetic argument, then, consists in the presentation of a set of similarities holding over the languages compared, and a demonstration that these similarities are not (likely to be) the result of chance, nature, or borrowing/diffusion. A genetic argument is thus a negative argument, or an argument by elimination, what in classical logic is termed a *disjunctive syllogism*. One rules out all but one of the logically possible accounts of relations of similarity, so that only inheritance from a putative common ancestor remains.

2.1 *The first premise of the comparative method*

It is not unusual for scholarly papers on historical linguistic topics, and linguistics courses on the comparative method and its application, to deal with the possibilities of chance resemblances between languages, and of resemblances through borrowing/diffusion. The possibility of natural resemblance is addressed much less often. By *natural resemblance* I intend those instances of similarity between linguistic objects that are simply not surprising, and do not, by their nature, call for any account. In order to be any more precise, we must permit ourselves to be informed by insights from what can be termed “classical semiotics,” in particular, to the semiotics of the late nineteenth-century American philosopher C. S. Peirce.⁸

Peirce’s semiotics involved a number of three-way distinctions – Peircean trichotomies. The best-known is one based on a sign form’s “fitness to signify”:

- i *indexical signs*, whose forms are fit to signify by virtue of being *part of* their object;
- ii *iconic signs*, fit to signify by virtue of some similarity between the sign form and its object; and
- iii *symbolic signs*, fit to signify by virtue of some convention or agreement that their forms will stand for particular objects.

As Saussure pointed out, only in the case of symbolic signs is the sign relation arbitrary. Since indexical and iconic signs are natural (non-arbitrary), we have no reason to be surprised by their cross-linguistic similarity. It is only in the case of *arbitrary* relations between the form and the meaning of linguistic signs that comparativists ought to find cross-linguistic similarity surprising. Comparative historical linguists *only* have cause to be surprised by, and must seek explanation for, similarities between form–meaning pairings in different languages *when those pairings are symbolic*.

So the comparativist is on the safest ground by restricting comparison to those linguistic signs that are the most arbitrary and conventional – individual lexical items. One has no strong warrant to infer genetic relatedness from similarities in iconic signs – onomatopoeic forms, metaphors, compounds, or syntactic patterns – since such similarities can be explained in terms of the limited possibilities afforded by observation and analysis of the world.⁹ I will refer to the restriction of comparison to symbolic signs as the *semiotic restriction* on, or the *first premise* of, the comparative method.

It is, therefore, the first premise of the comparative method that focuses attention on the lexica of the languages compared, and not the fact that nineteenth-century linguists couldn’t do syntax, or anything of the sort. At the risk of unnecessary repetition, we have no clear warrant to compare anything other than symbolic linguistic signs, because sign similarity is only surprising when the signs are symbols. This fact does not mean that we must restrict comparison to monomorphemic signs, but it does mean that we are on increasingly thinner comparative ice the more abstract/less symbolic the signs we compare.

2.2 The relation cognate with

It is tempting to think of the relation *cognate with* as differing only in domain from the relation *genetically related*. The latter, defined over languages, would be in some sense the *sum* of instances of the relation *cognate with*, defined over individual linguistic expressions, grammatical rules, or whatever. But that interpretation confuses reality, what actually is the case, with demonstrability, what we can show to be the case on the basis of available evidence and “the state of the art.” Two languages¹⁰ can, in principle, be genetically related without a single cognacy relation being evident in the synchronic states of those languages. That is, those languages might be genetically related, without our being able to adduce any evidence of that relatedness. And that is precisely what instances of the *cognate with* relation are – a demonstration of genetic relatedness. If one can *prove* that even one single cognate pair holds over two languages, one has proven those languages genetically related.¹¹

Two linguistic objects σ_1 and σ_2 are cognate:

$\text{cognate}(\sigma_1, \sigma_2) [\equiv \text{cognate}(\sigma_2, \sigma_1)]$

iff both are reflexes of a single antecedent linguistic object $*\sigma$:

$\text{reflex}(\sigma_1, *\sigma_1) \wedge \text{reflex}(\sigma_2, *\sigma_2) \wedge *\sigma_1 = *\sigma_2$

A linguistic object σ_t is a *reflex* of¹² a linguistic object $\sigma_{t'}$ if:

- i σ_t and $\sigma_{t'}$ are in temporally distinct language states t and t' (t subsequent to t') and if:
- ii σ_t is a “normal historical continuation” of $\sigma_{t'}$

Being more precise about what is meant by “normal historical continuation” isn’t easy. It must involve notions like “normal language acquisition” and “normal language change.”¹³ Although there may be some danger of circularity here, it seems to me safe to assume that historical linguists will know what I have in mind.

As noted above, comparative historical linguists must identify instances of the *cognate with* relation in order to demonstrate genetic relatedness. Even the techniques of “mass comparison” (as evidenced, for example, in Greenberg 1987; Ruhlen 1994), or any other method that begins with the mere observation of similarity, must ultimately trade in cognates. There is no other logical possibility, in the absence of written records or time machines. The comparative method is simply the principal (indeed, the only) means available to historical linguists for identifying cognates *convincingly*.

2.3 Phonological comparison and the regularity assumption

Let me stress this point again. The relation *cognate with* is independent of the comparative method. Though the comparative method is a technique for

identifying cognates, cognacy can exist without the comparative method being able to demonstrate it. That is, the comparative method has limits.

The most immediate limit on the method is the one faced by the working comparative historical linguist even before she or he sets off to hunt for cognates. The problem is *where* in language to look for cognates. One could look anywhere (a point taken up below with regard to grammatical comparison in section 3.1). But the comparative method, I would argue, is not designed to demonstrate cognacy in general, but cognacy only in the *lexicophonological domain*.

For the remainder of this section, I will assume that candidates for cognacy testable by the comparative method are (possibly morphologically complex) linguistic signs whose phonological shape is in a form no more abstract than (taxonomic) phonemic. That is, I assume we are comparing morphemes or morpheme sequences, in phonemic notation, up to the level of the phonological word.

As observed at the end of the preceding section, the comparative method is a procedure for identifying n -tuples that are instances of the *cognate with* relation, at some reasonable level of confidence. I will assume that any pair of items f and g , from different languages and meeting the domain conditions, are potential cognates. And I will use the possibility operator M of modal logic to represent potentiality. The problem of proving cognacy for potentially cognate pairs can be reduced to or recast as the problem of defining a rule of *M-elimination* that licenses the move:

M cognate(f, g)
cognate(f, g)

The comparative method is an attempt at defining this rule of *M-elimination*. The following is an informal approximation:

M-elimination

A pair (f, g) of potential cognates is a cognate pair if:

- i they meet a *similarity condition*: that f and g are *similar* in both facets of the sign relation, in form and in interpretation, and
- ii they meet a *disjunctive elimination condition* that the similarity is not (likely to be) a consequence of *chance* or of *borrowing/diffusion*.

2.3.1 The similarity condition

Condition (i), the similarity condition on potential cognates, is logically prior to condition (ii), on non-genetic accounts of the similarity. After all, you have to recognize similarity before you seek to explain it! But that fact does not make the similarity condition a *precondition* (that is, a condition on *potential* cognacy), as often seems to be assumed. I choose to view condition (i) as part of the *proof* of cognacy (as part of *M-elimination*) because I believe that the definition of similarity is in fact *part* of the comparative method, at the very least, as the method was first devised.

Under this interpretation, it is the similarity condition of the comparative method that rules out natural (i.e., iconic) similarities and enforces the *semiotic restriction* on the comparative method. With the comparative method, we restrict comparison to symbols because it is only similarity between arbitrary and conventional (*symbolic*) signs that is surprising, and that could be evidence of cognacy.

Similar symbols must be similar in both form and interpretation. While it may not be entirely fair to say that comparativists have done nothing to clarify the notion “similar meanings,” we haven’t done much. Most recent work has focused on *grammaticalization*,¹⁴ the process by which reference to particular sets or relations in the world changes into higher-order reference: motion verbs to source/goal markers, object–part relations (like “top surface” or “cavity beneath”) to object–location relations (like “on” or “under”), and so forth. But we are still very much at the data-collection stage in this endeavor, and are informed in it only by vague senses of what are possible metaphors or metonymies. Sadly, we don’t really pay much attention to the meaning side of things. In general, unless a particular meaning comparison grossly offends some very general sense of metaphor, it’s “anything goes” with regard to meaning.

Comparative historical linguists have been rather more careful in stipulating what it means for linguistic symbols to be similar in form. Observe first that similarity of form must be *complete* similarity. Put rather brutally, if the front halves of two forms are similar, but the back halves aren’t, then the forms are not similar. In practice, we observe this condition by segmenting each form into its component (segmental or autosegmental) parts, and then mapping the segmented forms into a set of *correspondences* between a part or parts of one form and a part or parts (possibly nil) of the other. We need not go into the mechanics of that segmentation process here. The problem of the similarity of sign forms then reduces to the problem of similarity of objects in a *correspondence* relation. And that, as we shall soon see, is not a problem at all!

Feature (attribute-value) theories of phonological representation (and of articulatory description that precedes them) make it possible for us to measure the similarity between two representations of phonological form, in terms of shared attribute-value pairs. Phonological feature theories do not, of course, tell us precisely how many attribute-value pairs must be shared by two forms for them to be deemed sufficiently similar to be cognate. Nor is it clear how one would, in practice, begin to construct a method that makes such a determination.

2.3.2 *Regularity, similarity, chance, and borrowing*

The good news is that comparative historical linguists, using the comparative method, do not need any measure of relative similarity that decides when two forms are similar enough. In fact (and a fact that is not, I think, widely appreciated), comparative historical linguists don’t need, and have never really needed, a theory of phonetic similarity at all.¹⁵ What we have instead is the *regularity assumption*.

I use the term *assumption* here quite purposefully, because it is by now well demonstrated that sound change is not regular, in the usual intended sense, but precedes in a quasi-wavelike fashion along the social and geographic dimensions of the speech-community, and through the linguistic system itself. At any given point in time, a particular sound change may be felt only in a part of the speech-community and, if it affects lexical signs, only through a portion of the lexicon.¹⁶

Why then do we cling to this assumption, when it is so demonstrably false? For two reasons, it seems. First, given enough time, sound changes will *tend* toward regularity; they will continue through the community and through the linguistic system until close to all speakers and close to all appropriate sign tokens are affected. Second, and more significantly, the *assumption* of regularity stands in for a theory of (or a measure of) form similarity. The actual form of two phonological types in a *corresponds to* relation is irrelevant; all that matters is that the relation holds for *all* tokens of those two types (under any appropriate local conditions).

One function of the regularity hypothesis is to filter out chance resemblances, which are quite unlikely to be regular and, to a lesser extent, to filter out borrowings, so long as the borrowing has not been on a massive scale and, if from related languages, has not been subject to nativization rules that lend to borrowings the appearance of regularity. To be sure, the regularity hypothesis does help enforce the *disjunctive elimination condition*. But it is much more than that. To early comparativists, it was a methodological *sine qua non* of the comparative method, enabling the work of comparative historical linguistics to proceed in the absence of any theory of phonetic similarity. Indeed, many of the data on which present theories of phonetic similarity were constructed are derived from the regular correspondences of the comparative method. And even now, with our feature theories informed by 150 years of work on both synchronic and comparative historical phonology, we cannot dispense with the regularity hypothesis, because it saves us from having to determine just how similar similarity must be, in order to demonstrate cognacy.

3 The Limits of the Comparative Method

Having outlined the essential features of the comparative method, as I understand it, let me at last turn to the issue of its limits and limitations. I divide these into two rough groups:

- i limitations deriving from the interaction of language data and the method;
- ii limits imposed by the method itself.

The first group consists of those situations in which the facts of language change, in particular circumstances, can conspire against the comparative method. These are essentially situations in which the method hasn't appropriate language data on which to operate. The problems that fall within this group include:

- i the temporal limit problem;
- ii the massive diffusion problem;
- iii the subgrouping problem.

The second group consists of those linguistic domains for which the comparative method is simply not designed to operate. To discuss these limits one must address the domain problem on cognacy, in particular the issue of grammatical comparison and reconstruction.

3.1 Comparing grammatical objects

Section 2.3 above introduced what might be termed the *domain problem* for the cognacy relation. Those who use the comparative method must recognize that words or morphemes are in the domain of the cognacy relation. Cognacy between phonological units like phonemes can also be admitted (if *cognate with* is defined in terms of *reflex of*, as suggested in section 2.2 above).¹⁷ But what other linguistic objects are in the domain of the *cognate with* relation – syntactic categories, syntactic rules, paradigms? Is a syntactic rule or morphological paradigm of Portuguese, for example, to be considered a reflex of some rule or paradigm of (Vulgar) Latin, and thus potentially cognate with some similar object in French or Romanian? The quick answer to these questions is, I think, yes.¹⁸ But a qualified yes, the qualifications being that:

- i the cognacy of such objects cannot be determined by the comparative method, and that
- ii genetic relatedness cannot be determined on the basis of the putative cognacy of such objects.

Grammatical objects are different in their degree of abstraction from the lexicophonological objects on which the comparative method operates, and that difference is crucial to how we interpret those objects historically. But a slight synchronic excursus is in order, to flesh out what is intended here by the differing abstractness of lexicophonological and grammatical objects.

3.1.1 The nature of grammatical objects

An interesting insight in Head-driven Phrase Structure Grammar, at least in its early incarnations (for example, Pollard and Sag 1987), was the manner in which it generalized the notion “linguistic sign.” The term “linguistic sign” is often treated as if it were synonymous with “morpheme,” in the American structuralist sense of that term. In HPSG, it is explicitly generalized along two dimensions:

- i internal complexity;
- ii abstraction.

Any linguistic form with an interpretation and/or function is a linguistic sign,¹⁹ from the non-compositional morpheme at least up to the level of the sentence. The major difference between morphemes and sentences is that the former,

but not the latter, are paired with their interpretations in a lexical listing, while the latter are semantically compositional (in theory at least). The type of information each contains differs, of course, but that fact doesn't detract from their fundamental similarity.²⁰

Consider the following pair of pseudo-HPSG attribute-value matrices:

$$\text{a. } \left[\begin{array}{l} \text{cat: cn} \\ \text{syn: } \left[\begin{array}{l} \text{agr: } \left[\begin{array}{l} \text{num: sg} \\ \text{gen: masc} \end{array} \right] \end{array} \right] \\ \text{phon: /gato/} \\ \text{sem: } \lambda x.\text{cat}(x) \end{array} \right]$$

$$\text{b. } \left[\begin{array}{l} \text{cat: cn} \\ \text{syn: } \left[\begin{array}{l} \text{agr: } \left[\begin{array}{l} \text{num: sg} \\ \text{gen: masc} \end{array} \right] \end{array} \right] \\ \text{sem: } \lambda x.f(x) \end{array} \right]$$

Matrix (a) might be a partial representation for the Portuguese *gato* “cat,” while matrix (b) is derived from (a) by abstracting away certain information (in this case, the item-specific phonological and semantic information). Matrix (b) is a representation of an abstraction, of a set of linguistic signs; in this case, set-denoting masculine singular common nouns. If (a) had been a complex sign like a noun phrase or sentence, then the corresponding abstraction (b) could be interpreted as a template or phrase structure rule for complex objects like noun phrases or sentences.

Grammatical objects, then, are abstractions on actual linguistic signs; on words, phrases, clauses. These abstract objects can still be considered signs, form–meaning pairings, to the extent that:

- i we are willing to regard *as form* the structural information remaining after actual phonological shape has been abstracted away, and
- ii it is possible to associate some meaning with such grammatical abstractions.²¹

The meanings associated with grammatical objects are of course themselves likely to be quite abstract. For example, the meaning associated with the category “cn” (common noun) in analysis (b) above is just “predicate on (or set of) individuals.” But the meanings of grammatical or functional items like tense or plural markers are no less abstract than these, so their status as meanings should not be in doubt. In the following sections, I consider whether these grammatical objects can be compared, reconstructed, and used as evidence in genetic arguments.

3.1.2 *The comparison of grammatical objects*

Genetic linguistic inferences follow from the fact that, in certain circumstances, we can be justifiably surprised at similarities between different languages. The comparative method, as understood here, provides two essential tools that

make *genetic* inferences possible. In its data domain, it provides the reason to be surprised, in that similarities in symbolic form-meaning pairings cannot be attributed to nature, and are unlikely to be the result of chance. In its method, and in particular in the regularity assumption, the comparative method provides a “measure” of similarity.

Grammatical objects fare poorly as evidence for genetic relatedness under the comparative method on both these counts. On the one hand, we have little reason to be surprised at the particular form-meaning pairings observed in grammatical objects. On the other, there can be no regularity assumption for grammatical objects to provide a measure of similarity.

Observe first that there can be no regularity assumption for grammatical objects because these objects are unique. The reason is axiomatic, and thus beyond question. It is a theoretical premise in linguistics that individual simplex linguistic signs reside in a lexicon, a repository of linguistic unpredictability. We can thus speak of individual lexical items undergoing or not undergoing some sound change, because those items exist individually. Modern linguistics accepts as axiomatic that complex linguistic signs, by contrast, do not reside in some vast “grammaticon,” from which they are drawn as needed in language production or reception. Rather, they exist as latent or potential linguistic signs, in the grammatical objects onto which they are abstracted. It is thus incoherent to speak of a grammatical change being regular, since a grammatical change applies in only one abstract object.

We can nonetheless compare grammatical objects in different languages, and describe the degree to which they are similar. But just how similar must two grammatical objects be for that similarity to be surprising, and thus count as evidence of genetic relatedness?²² The question is not even an interesting one, though, because similarities between grammatical objects are seldom, if ever, surprising.

Grammatical objects are templates, diagrams, or rules encapsulating what is common in sets of (simplex or complex) linguistic expressions. For the most part, grammatical objects are iconic, and not symbolic signs. This is true both for syntagmatic signs abstracted from complex linguistic signs and encapsulating combinatory linear or hierarchical information, and for paradigmatic signs abstracted from sets of lexical items and encapsulating selectional information.

Syntagmatic signs are iconic to the extent that they are compositional. If the syntagmatic information in a grammatical object, whose meaning is a function of the meanings of its component parts, is information that those parts are adjacent or overtly coindexed in some way (by agreement morphology, for example), then this information is not surprising. The “closeness” in form is iconic of association in meaning. Indeed, we would be surprised if this were not the case. And if the syntagmatic information is simply hierarchical, syntactic dominance information, there seems to me to be no question of whether or not to be surprised by association of this formal property with some semantic operation; the hierarchical association *is* the semantic operation.

In the literature on syntagmatic object comparison, semiotic considerations have run a distant second place to arithmetic-combinatoric considerations

in the more restricted domain of word order comparison.²³ Thus, a common account of the failure of the comparative method in *syntax* (read, *word order*) is the *poverty of choice* argument. In the case of comparisons of Greenbergian major clause constituent typologies,²⁴ that argument runs as follows: since there are only $2^3 (= 8)$ possible permutations of the major clause constituents S(subject), V(erb), O(object), there is a 1:8 chance of any two languages sharing a (predominant) major clause constituent typology by accident, and that probability is too high to discount accident.

As compelling as the poverty of choice argument may be, in itself it is of less significance to the issue of grammatical object comparison than is the approach to grammatical theory it presupposes. What gives rise to the poverty of choice (in this case, eight possibilities for major clause constituent order) is an analysis of (transitive) clauses that assumes a limited number of major clause components (in this case, three), and a theory of grammar that permits the identification of those components cross-linguistically. It is the theories of grammar to which most linguists subscribe, and their assumptions of universality, that give rise to the poverty of choice, and deprecate grammatical object similarity as evidence of genetic relatedness. We can never be surprised by the fact that two languages share some property that is universal.

Grammatical objects need not be universal in the strong sense of the preceding paragraph for their value as genetic evidence to be questioned, as was observed above for the case of compositional syntagmatic objects. But this fact is not just true for compositional objects. Any system of grammatical contrasts is iconic to the extent that it reflects a distinctly human ontology. This is true of the systems of categorial contrast associated with X' theories of phrase structure, and is true, in exactly the same way, for inflectional paradigms.

Inflectional paradigms can be viewed as metaphors, as iconic of a highly constrained analysis of the world, given expression in the structure of language. Systems of person-number marking, for example, map onto a characteristically human manner of indexing individuals in linguistic communication – for single individuals, as speaker, hearer, or neither and, for more than one individual, as including the speaker, the hearer, or neither.²⁵

Cases like those of morphological person-number paradigms are of particular interest because, although not universal in any absolute sense (but see further below), linguists are surprised neither by their occurrence nor by their non-occurrence in the verb or common noun morphology of particular languages. For example, Mokilese and Ponapean are two very closely related Micronesian languages, verging on mutual intelligibility. Ponapean, like most Micronesian languages, has a transitive verb paradigm, with distinct suffixed forms indexing the person-number of the direct object. Mokilese transitive verbs are invariant, the person-number of the object being marked by independent pronouns when necessary. The Ponapean suffixal transitive paradigm is similar in structure to that found in Biblical Hebrew transitive verbs (and those of other modern Semitic languages). To be sure, there are differences in the structure of the Hebrew and the Ponapean paradigms; Ponapeic languages do not make gender distinctions, and Hebrew does not have the dual-plural

direct object contrast found in Ponapean,²⁶ or the inclusive–exclusive contrast. But exactly the same is true of at least one other Micronesian language, Gilbertese, with an object-indexed transitive verb paradigm identical to the Hebrew, except in not making the gender distinctions found in the Semitic paradigm. And, finally, one might observe that Mokilese and English are similar in not having object-indexed transitive verb paradigms at all.

Comparative linguists might wonder how the situation arose in which two languages as closely related as Mokilese and Ponapean are could differ in this significant respect. But no comparative historical linguist would cite the paradigm similarities between Gilbertese and Hebrew, or English and Mokilese, as evidence in a genetic argument. We are surprised neither by the occurrence nor by the non-occurrence of morphological object paradigms because we believe them to be, in some sense, latent in the human language faculty. And, indeed, this particular latency has been elevated to theory-licensed universality in recent proposals for AGR_O (an object-agreement constituent) in Principles and Parameters and in Minimalist syntax.

In summary, if one were able to identify grammatical objects that are not iconic in any of the senses considered above, but, rather, reflected some arbitrary means of mapping between the categories of language and of the world, then one could speak of comparative grammatical evidence of genetic relatedness. Radical Whorfians would have little trouble finding such cases. For most of us, though, the task would be much more difficult.

3.2 *The reconstruction of grammar*

The comparative method *sensu stricto* is a method for determining genetic relatedness amongst languages. While some aspects of the proto-language are reconstructible as a by-product of the comparative method, that is not the method's primary function. One can use the comparative method to draw genetic conclusions without reconstructing a thing!

For the reasons outlined here, I do not believe that the comparative method can be applied to grammatical objects (as described in the preceding section) to determine genetic relatedness and to reconstruct antecedent grammatical objects. But let me now temper that view by saying that I believe it is possible to compare and reconstruct grammatical objects, using other methods, *after genetic relatedness has been established*.

Once we know that two languages are genetically related, we know that at least some of the grammatical objects in those languages are reflexes of objects in their common parent, and that some of those are likely to be cognate. And once parallel separate developments and borrowings are weeded out, all that remains is to tell a plausible story about how grammatical objects in different languages developed from a single antecedent grammatical object. But such historical inferences about grammatical objects are not being guided by the comparative method, but by some other principles, because we can draw no genetic conclusions from them.

3.2.1 Undoing grammaticalization

So, not all linguistic comparison necessarily instantiates the comparative method. Nor, of course, is all linguistic reconstruction comparative. There is the “method of internal reconstruction,”²⁷ by which morphophonemic alternations are undone in putative antecedent linguistic states, and the as-yet-unnamed (and less often taught) techniques for “undoing” *grammaticalization*, by which earlier grammatical forms and constructions are inferred from synchronic observations regarding lexicon, morphology, and syntax. DeLancey (1994b) quite correctly observes that these techniques are a form of *internal* rather than *comparative* reconstruction.

A consideration of these techniques of internal grammatical reconstruction, by which instances of grammaticalization are undone, is not properly within the scope of this chapter. But these techniques are entrancing, and have yielded, for me, a number of papers, published and unpublished, on the grammatical history of Oceanic (and, particularly, Micronesian) languages. I thus cannot leave them without comment.

3.2.1.1 Typological consistency of word order

Let me first off distinguish between two quite distinct premises for undoing grammaticalization. The first is that the relative order of clitics and their hosts, and affixes and their stems, reflects the earlier order of complements and their heads or (attributive) operators and their operands. This premise allowed Givón (1971), for example, to infer historical OV constituent order from English compounds like *baby-sit* or *donkey-ride*. The technique seems to get considerable support from cases, like Romance, where the history is known. Given that Classical Latin was OV,²⁸ while its Romance descendants (and their hypothetical post-Classical ancestor, Vulgar Latin) are VO, the fact that Romance pronominal clitics are pre-verbal seems to hark back to the putative Latin situation; that is, until one observes that metropolitan Portuguese, which is apparently morphosyntactically conservative in a number of respects, has enclitic verbal pronouns.²⁹

This use of internal reconstruction, to recover older word order, suffers from a similar problem to that of its better-established morphophonological cousin; both involve a “historical uniformity” assumption. In standard “internal reconstruction,” one assumes that phonological alternation develops from prior non-alternation; in word order reconstruction, one appears to have to assume that constituent order was typologically consistent at some point in time. The prior uniformity assumption underlying morphophonemic internal reconstruction is not particularly problematic, but the parallel syntactic premise is questionable, because it is, in fact, a much wider claim. All that is being assumed in morphophonology is that the particular alternation in question reflects the operation of conditioned sound changes on historically non-alternating forms.

We are not warranted in assuming any more in the syntactic cases; that is, we can assume that the constructions antecedent to the English N-V compounds were [N V], and that the constructions antecedent to the Romance pro-V clitic structures were [pro V] (*pace* Portuguese). What we are *not* safe in assuming is

that all (or any other) [V, NP] complement structures in either pre-Romance or pre-English were verb-final, any more than we are safe in assuming that any synchronic grammar will be typologically consistent. In short, we can infer something from synchronic word order, but not much.

3.2.1.2 *Semantic bleaching*

A second technique for undoing grammaticalization is employed on cases of "semantic bleaching." These are instances in which morphemes have much of their particular semantic content abstracted away. For example, relational common nouns (like 'bottom' or 'surface') develop into thematic-role markers. Motion verbs and modals come to have temporal marking functions, demonstratives become articles or complementizers, and so forth. This phenomenon has been recognized in the literature for some time (see, e.g., Benveniste 1968; Givón 1975).

One argument form commonly employed to recover instances of semantic bleaching begins with observations of polysemy/homonymy in a language. A particularly transparent case is that of Gilbertese *nako*, which has three functions:

- i a motion verb 'go'
Nako mai.
go hither
"Come here."
- ii a directional enclitic 'away'
E matuu nako.
3s sleep away
"She or he fell asleep."
- iii a preposition 'to(ward)'
A boorau nako Abaiaang.
3p voyage away Abaiaang.
"They travelled to Abaiaang."

Using the premise (the second mentioned above) that polysemy/homonymy is likely to be the result of semantic change, one postulates a single form and function for sets like *nako*, and constructs a plausible history to account for the observed polysemy/homonymy. The technique is clearly a form of internal reconstruction, in which the alternation being eliminated is semantic rather than phonological.

The case of Gilbertese *nako* is not only a transparent one, but also one for which there is no obvious *synchronic* analysis of the observed polysemy/polyfunctionality.³⁰ As is doubtless true of most historical grammarians, I have been tempted over the years to resolve other, less trivial cases. For example, in Harrison (1982), I used both internal arguments and comparative evidence in a historical resolution of the Gilbertese agentless passive suffix *-aki* and a particular transitivizing suffix *-akina* restricted to motion/stance and some psychological state verbs. The subsequent publication of Burzio's (1986) observations regarding the unaccusativity of a similar semantic class render that resolution much less fanciful than it may have appeared at the time.

3.2.1.3 *Grammar and the comparative method*

Yes, comparative evidence is used in reconstructing grammatical items, but this is not the comparison and reconstruction of grammatical objects as defined in section 3.1. Much of what is called grammatical reconstruction in the literature is just the plain vanilla comparative method applied to morphemes in the usual way.³¹ The main difference is that the morphemes have glosses like ‘to,’ ‘present,’ and ‘ergative marker,’ rather than ‘sun,’ ‘wind,’ and ‘fire.’

When abstract “grammatical” items are compared, it is often the case that the formal phonological relationships between the items compared are less an issue than are the functional semantic relationships. A comparativist who pays little attention to the glosses of putative cognates, as long as they are in the right semantic neighborhood, will often become much more demanding regarding grammatical items. A case in point: Proto-Micronesian **fanga-ni* ‘to give’ is easily reconstructed on the basis of cognates in Gilbertese and Trukic. My suggestion (Harrison 1977) of a Ponapeic cognate in Ponapean *-eng* and Mokilese *-oang* has not been universally accepted by other Micronesianists. The historical phonology is perfect. The problem is that the Ponapeic form is a verb enclitic marking dative/goal arguments.

This may be healthy skepticism in general, because the only limit on the language-internal or comparative cognacy of grammatical items is our sense of metaphor and of possible semantic relation. And some historical linguists can be very imaginative indeed. But one shouldn’t be too skeptical of this endeavor, because what those engaged in the comparison and reconstruction of grammatical items are doing (albeit in rather circumscribed domains) is something the field as a whole should have been attending to all along – the comparison of meanings.

3.2.1.4 *The role of morphology and the significance of oddity*

Meillet is credited with the assertion that “morphological” evidence is stronger evidence of genetic relatedness than is mere phonological correspondence. The claim seems to derive from a discussion in Meillet (1948), where he states (pp. 24–6, given here in translation):

From the principle underlying the [comparative] method, it follows that, within the domain of comparative grammar, the probative facts are idiosyncrasies, and they are so much the more convincing as, by their very nature, they are less suspect of being attributable to a general cause. This is only natural: given that what is at issue here involves positing, via comparative procedures, the historical fact of the existence of a particular language – that is to say, of a thing which, by definition, arises due to a series of diverse circumstances which have no necessary connection with one another – it is these characteristic idiosyncrasies alone which must be taken into consideration.

Meillet then continues with an example from the paradigm of ‘to be’ in a number of Indo-European languages. Teeter extrapolates from that discussion the claim that “knowing that German has a verb ‘to be’ with a third singular

ist and third plural *sind*, and that Latin has one with a third singular *est* and a third plural *sunt*, is all by itself sufficient to guarantee the relatedness of German and Latin" (Teeter 1994b). This Meillet–Teeter conjecture is not a claim that the structure of the morphological paradigm (i.e., a grammatical object, in the sense of section 3.1) is evidence of genetic relatedness, but that the presence of particular fillers in particular slots of the paradigm is evidence of genetic relatedness.

Let me make two points about this issue. The first is merely to reiterate my views about the status of grammatical object similarity as evidence for genetic relatedness. The fact that Polish and Lithuanian both have a common noun paradigm that distinguishes two numbers (singular and plural) and seven cases (nominative, genitive, dative, accusative, vocative, locative, and instrumental) is not evidence that the languages are genetically related. It only becomes evidence when the phonological shapes of the characteristic markers (of some significant number) of those paradigm slots are also similar,³² as the comparative method would require.

The second is to question the claim that *ist/est* and *sind/sunt* have privileged status as evidence of genetic relatedness. Teeter claims their special status derives from the fact that they are "grammatical lookalikes, guaranteed to prove genetic relationship because grammar (short of learning a language) is exempt from borrowing" (Teeter 1994c). It is not clear what a "grammatical lookalike" is, but it is clear that two putative cognates are not exempt from the usual strictures of the comparative method just because they happen to be members of a high-frequency morphological paradigm. And, as Thomason and Kaufman (1988) point out, *nothing* is exempt from borrowing.

Teeter's motivation seems clear to me, because it is at the heart of the comparative method. Like many of us, he wants some sort of evidence that is guaranteed to satisfy the disjunctive condition of section 2 – something odd, outstanding, or irregular. The principal virtue of the comparative method is just that its logic doesn't demand that we seek out oddities, but regularities.

Manaster Ramer (1994) points to examples of what he regards as odd syntax, and suggests that their oddity alone makes them reconstructible. His principal example is the singular verb agreement of neuter plural nouns in Old Iranian and Ancient Greek.³³ Since he seems to be suggesting that such syntactic oddities are unlikely to have arisen by chance or been borrowed, then it would appear to follow that he regards them as evidence of genetic relatedness. But the whole argument rests on the premise that a certain sort of grammatical object is odd. A principled definition of "grammatical oddity" is desirable, before one can accept such evidence.³⁴

3.3 False negative results from the comparative method

The comparative method was not designed to operate on non-lexical data. There are at least two situations in which the comparative method fails on lexical data, in not recognizing genetic relatedness amongst languages that are genetically related. These are:

- i very long absolute time depth for the proto-language;
- ii massive diffusion of lexical items across a multilingual domain.

3.3.1 *Time depth*

Time is both parent and adversary to the comparative method: without change through time, there is nothing to compare; with enough change over enough time, comparison yields nothing. That is the most basic lesson in comparative linguistics. The more time that elapses from the initial break-up of some ancestral language, the more difficult it will become to demonstrate the kinship of its descendants.

The effect of time has nothing whatsoever to do with any putative upper limit on the comparative method. It has to do with the availability of evidence. The more time, the more change, the more lexical replacement, the fewer cognates: end of story. The limit is a practical (and statistical) one, not a temporal one. When the number of putative cognates and/or correspondence sets approaches a level that is not statistically significant (i.e., that might be attributable to chance), the comparative method has ceased to work.

Johanna Nichols (1992a), among others, muddies the waters somewhat by stating the restriction in terms of absolute dating (8000–10,000 years). In a thread of discussion on the time-boundedness of the comparative method, she qualifies quotes like: “But the comparative method does not apply at time depths much greater than about 8000 years (this is the conventional age of Afroasiatic, which seems to represent the upper limit of detectability by traditional historical method)” (Nichols 1992a: 2–3) by saying that one arrives at such absolute limits not by analysing the comparative method, but by examining the “oldest uncontroversial genetic groupings” (Nichols 1994b) and, one assumes, using the oldest date amongst those (which she suggests is that for Afro-Asiatic).

As others rightly asked in the subsequent discussion: where do those dates come from? Only two places, so far as I am aware. One possibility is from the archeological record, if there is some reason to associate a particular datable assemblage with a particular node on a genetic linguistic tree. For example, many Austronesianist prehistorians have sought to associate the Oceanic node on the Austronesian family tree with the Lapita pottery culture.³⁵ The other source of dates is glottochronology, in one guise or another. For glottochronology, one must make some assumption about the rate of lexical replacement/retention. The constant *r* usually cited is 14 percent replacement (86 percent retention) per millennium. As has often been pointed out, Bergsland and Vogt’s (1962) paper should have put paid to the notion that there is such a constant, but it seems that each new generation of comparative linguists must learn this lesson anew.³⁶ I side with Jacques Guy (1994) on this one, when he says: “Short of datable documentary evidence – such as lapidary inscriptions, clay tablets, etc. – there is no way to date putative ancestors, no way at all.”

What interests me most of all is why so many historical linguists feel drawn towards absolute dating. Sure, it would be nice to know when, but

the comparative historical enterprise doesn't stop because that question can't be answered. It seems to me that the obsession with dates, like the obsession with family trees, is at least partly the result of "prehistorian envy." Too many comparative historical linguists want to dig up Troy, linguistically speaking. They consider it more important that comparative historical linguistics shed light on prehistoric migrations than that it shed light on the nature of language change. I can only say that I do not share those views on the focus of comparative linguistics. I do not consider comparative historical linguistics a branch of prehistory, and I sincerely believe that if we cared less about dates, maps, and trees, and more about language change, there'd be more real progress in the field.

3.3.2 Diffusion

In a number of papers, Grace (1981, 1985, 1990) reports the results of research conducted on the languages of southeastern New Caledonia over a 20-year period beginning in the mid-1950s. Grace's intention was to place these languages more accurately within the developing tableau of genetic relationships amongst the Oceanic languages. The problem had been that these languages were what Grace terms "aberrant," in that their phonologies did not correspond to the general Oceanic pattern. This historical accident, Grace reasoned, was what was obscuring their Oceanic genetic heritage. Grace also reasoned that if one reconstructed from those languages *alone*, the resulting reconstruction would undo much of what was aberrant about the southeastern New Caledonian languages, and facilitate comparison with other Oceanic languages.

Grace was able to collect extensive material on two SE New Caledonian languages, Canala and Grand Couli. An initial inspection of these data suggested some nine hundred possible cognate sets between these two languages. But, far from reducing the degree of "aberrancy" (relative to other Oceanic languages) of the New Caledonian languages, the results Grace obtained by applying the comparative method to these languages only made matters worse.³⁷

Both Canala and Grand Couli have identical inventories of 24 consonants and 18 vowels (oral and nasal). Grace identified 140 consonant correspondences (56 with more than 5 tokens) and 172 vowel correspondences (67 with more than 5 tokens). Nor was there much evidence of conditioned change to reduce the number of reconstructed segments. These results do not demonstrate genetic relatedness, even though it is obvious that the languages in question *are* genetically related. On one interpretation, the correspondences are simply not regular; on another, the reconstructed inventory is not that of a natural language.

Grace (1990) suggests two possible explanations for the situation observed in SE New Caledonia. The first challenges the regularity assumption. Under that account, a change begins, affects a few tokens, and stops. Another change begins, affects a few tokens, and so forth. As stressed earlier, attacking regularity is beating a dead horse. The falsity of the regularity assumption, as an account of how language change takes place, is evident. The assumption is a methodological,

not an empirical, necessity. In those cases in which it is grossly violated, as here perhaps, nothing can be done, because the method won't work.

But it is not clear that that is the better of Grace's two explanations. His second account relies on the sociolinguistic situation in southern New Caledonia. In that area, marriage is outside the local community, often (if not typically) into a community with a different language – whatever that might mean; for Grace also asserts that our European monolingual view of the world may not apply to this situation, because languages have “mixed” to the point that the notion of “pure” distinct languages might not make any sense.

If time is one great adversary of the comparative method, prolonged socio-economic intercourse amongst small-scale (genetically related) linguistic communities is another. Language contact and borrowing are a normal occurrence, and make comparative linguistics interesting. But most instances of borrowing can be recognized as such, and factored out. Even cases of massive borrowing (as a consequence of some cataclysmic event like invasion) can often be teased out. There is, for instance, the classic Oceanic case of Rotuman, as reported in Biggs (1965), where two distinct sets of correspondences ultimately revealed themselves, one native and one imposed from outside.

Grace's New Caledonian case is not like that. It appears to have been the result of a slow but relentless dissolving of lexical resources into a common pool. The effect on comparative historical method is profound too. We “know” the languages are related, but can't demonstrate that they are by using the logic of the comparative method. Nor is this case an isolated one. Though I am not an Australianist, from what I have come to know second-hand about the situation in parts of northern Australia (Arnhem Land, for example), a situation parallel to the New Caledonian one holds there. The languages are grammatically quite similar, often admitting of morpheme-by-morpheme translation. The lexica look comparable. But the method doesn't work.

3.4 *The special case of subgrouping*

3.4.1 *Simple genetic arguments and subgrouping arguments*

The subgrouping problem is different from what I might term the simple (or *in vacuo*) genetic problem with which the preceding sections of this chapter have dealt. The simple genetic problem is to determine, for some set of languages $L (= \{L_1 \dots L_n\})$, whether or not the members of some subset of L share a period of common history. Using the comparative method, one does that by finding regular sound correspondences over sets of putative cognates. The subgrouping problem is a *tree selection problem*. One has already determined, using the comparative method, which members of L are genetically related (as descendents of some $*L$). The subgrouping task is to select, from amongst all possible trees T (with no non-branching nodes, to keep things finite!) with root $*L$ and leaves L , the one tree $T \in T$ that best represents the genetic history

(order of speciation) of L. Put somewhat differently, a simple genetic argument demonstrates that there is (or is not) a tree whose leaves are some subset of the languages compared; *if* there is a tree, subgrouping arguments are used to decide which tree. In a real sense, then, subgrouping is logically subsequent to determining genetic relatedness via the comparative method.

Subgrouping is not just comparative reconstruction of a small number of languages from a larger sample. The raw data for both simple genetic and subgrouping arguments are the same – sets/patterns of (partial) similarity in the form of linguistic expressions – but the propositions that one seeks to prove about those raw data are not precisely the same. In a simple genetic argument, one seeks to show that the patterns of similarity are a consequence of retention of properties of a common antecedent state, and not of diffusion or (natural or incidental) accident. In a subgrouping argument, one seeks to show that the patterns of similarity are not a consequence of retention from an antecedent state, but of a *unique* event (or change) common to the histories of all the languages in the subgroup.

To obviate any misunderstanding, let me make this last point a bit differently. In a simple genetic argument, we don't care whether the observed similarity is the result of some earlier change (in the history of the proto-language), or whether it reflects a situation going back to the dawn of time. In a subgrouping argument, it is crucial that the similarity be a shared innovation of the period of common history of the subgroup, an event/change that took place before the subgroup began to speciate, but after speciation at the immediately higher level in the tree.³⁸

It is also significant that subgrouping arguments must make crucial reference to changes (events). When we seek to rule out borrowing or iconic or accidental similarity in simple genetic arguments, using the comparative method, we are talking about the borrowing or chance similarity of linguistic signs. In subgrouping arguments, we are talking about the diffusion or chance independent repetition of linguistic changes. The canons of evidence in evaluating changes and signs are not necessarily the same.

3.4.2 *The practice of subgrouping*

Let's restrict attention here to two sorts of subgrouping evidence:

- i evidence from lexical identity;
- ii evidence from phonological similarity.

In order to demonstrate, in such cases, that the observation of similarity/identity is the outcome of a single act (of lexical coinage or sound change), one must demonstrate that the similarity/identity is unlikely to have been:

- i retention from an earlier state, and not change, or
- ii independent change in the languages sharing the form, or
- iii diffusion of the change across language boundaries.

In Harrison (1986), I identified six heuristics (in the form of implications) guiding the subgrouping enterprise. Two that are relevant to the evaluation of single correspondence sets (as subgrouping evidence) depend on the following premises:

- i The fact that any change takes place at all is remarkable. (The act or occurrence of a change is of itself a remarkable event.)
- ii Some changes are more remarkable than others. (Changes can be, and indeed are, ranked in terms of relative naturalness.)

from which one can conclude:

- i' Since the act or occurrence of a change is of itself remarkable, identical outcomes are likely to reflect a single act of change.
- ii'a A tree that entails a relatively unnatural change is a poorer candidate as a diagram of genetic relationship than one that does not entail that change.
 - b Unnatural changes are less likely to be repeated independently than are natural changes, and so are stronger evidence for subgrouping.

Heuristic (i') is essentially an appeal to simplicity; trees that represent a history with fewer change events are to be preferred over those that entail more change events. Note that (i') seems to vitiate (ii'b) somewhat, since (i') doesn't demand that we consider the content of the change at all.

Let's try to make all this a bit more concrete, by considering how to evaluate, as subgrouping evidence, a single hypothetical sound correspondence for a set L of five languages:

L_1	L_2	L_3	L_4	L_5
p	p	f	f	∅

If we assume, for the moment, that all the outcomes in this set represent change from *L then, by (i'), we would want to draw the tree:

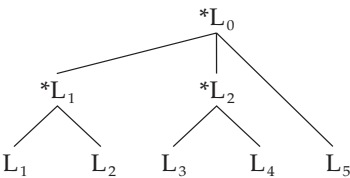

in order to minimize the number of actual events in the history. That history can be further simplified under the assumption that one of the outcomes reflects retention, rather than change. In the case in question, simplicity and simple arithmetic cannot be used to decide which outcome is the most likely retention, because at most one act of change is eliminated regardless of the choice made. But an appeal to (ii'a), through our linguists' understanding of the facts of change, does give an answer.

If we restrict attention to possible histories in which each language has undergone at most one change, the choices are:

- a * p > f; *p > Ø
 b *f > p; *f > Ø
 c Ø > p; Ø > f

Choice (c) is likely to be ruled out immediately as just too unnatural an unconditioned change. Of the remaining choices, most phonologists and historical linguists would probably select (a), on the grounds that lenition is more common/natural than fortition. In that case, we have the tree:

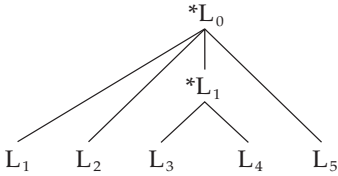

in which L_1 and L_2 are assumed to have undergone no change.

We could stop there, but one might reason, by (ii'b), that the change $p > \emptyset$ in L_5 is unlikely to have proceeded in one step, and that a two-stage lenition process (with an intermediate fricative stage) is more likely/natural. Since L_3 and L_4 show that fricative stage, and rather than assume two occurrences of $p > f$, we can simplify the history by subgrouping L_3 , L_4 , and L_5 , yielding:

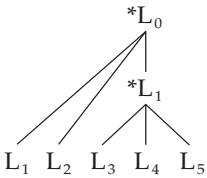

3.4.3 Evaluating subgrouping arguments

That is how subgrouping is done, from the perspective of single correspondences at least. Observe, first, that heuristic (i') (called the *strong act of change* warrant in Harrison 1986) addresses the possibility of identical independent change only by denying it, and provides no guidance in ruling out either retention or diffusion. It is rather like what the comparative method would be, stripped of the restriction to symbolic data, and without the regularity assumption. By itself, (i') provides relatively unmotivated subgrouping hypotheses.

Given some theory of (sound) change by which changes are ordered for plausibility, heuristics (ii'a) and (ii'b) (together called the *fact of change* warrant in Harrison 1986) ought to filter out at least some cases of shared retention and of identical independent change. But these heuristics are far from unproblematic. *First*, the goals of eliminating retentions and identical innovation are often in conflict. When faced with a putative unusual change, like $f \rightarrow p$, does one conclude that it is strong subgrouping evidence or that it is so unlikely that the

/p/ forms are shared retentions? *Second*, if the only good subgrouping evidence is evidence from unusual, unnatural changes, then, by that very token, such evidence will be in short supply, and it will be impossible to construct good subgrouping arguments simply because the evidence won't be there! *Third*, premise (ii) does not entirely rule out the possibility of unnatural change. There is very little to guide us in recognizing when an unnatural change actually *has* taken place. *Fourth*, and most damaging of all, is premise (ii) itself. There is, in fact, no theory of phonology or of sound change by which changes can be ordered for naturalness. Modern phonological theory, in a diachronic guise, can be interpreted as an exercise in motivating all observed phonological alternation and sound change. Our notions regarding naturalness are grounded in nothing more than vague intuition and anecdote. In the absence of a true theory of relative naturalness, the use of premise (ii) in subgrouping arguments is, quite literally, unmotivated.

In simple genetic arguments using the comparative method, accidental similarity and borrowing, as accounts of similarities between forms, can be eliminated for the most part by restricting data to symbols and by the regularity assumption, respectively. There are no parallel means for eliminating diffusion and identical independent change, in a principled fashion, as accounts of shared *changes* in subgrouping arguments. Diffusion, it seems to me, is never going to be easy to rule out, except in cases in which the putative subgroup is geographically discontinuous (but see further below). To rule out identical independent development, we must rely on premises (i) and (ii) above, and they are far from unproblematic.

Eliminating "shared retention from an earlier antecedent state" as an account of similarities in outcome is a problem unique to subgrouping. The comparative method can give us no guidance, so we must again depend on heuristics like those following from premises (i) and (ii). As an example of the problems involved, consider the case of the Romance verb "to eat":

Portuguese	comer
Spanish	comer
Catalan	menjar
French	manger
Italian	mangiare
Romanian	mînca

For convenience, I label the two roots in question C and M. It would appear at first glance that, for lexical data like this, we can at least rule out the possibility of identical independent change. And, for the sake of this argument, I ignore the possibility of diffusion. Three possibilities remain:

- i C is a retention, and M an innovation (of subgroup {Cat, Fre, Ita, Rom});
- ii M is a retention, and C an innovation (of subgroup {Por, Spa});
- iii both C and M are innovations (and evidence of two subgroups).

The “right” answer is iii, more or less. Both C and M are reflexes of Latin verbs: *comedere* ‘to eat out of house and home’ and *manducare* ‘to chew.’ So both forms are in fact retentions. The innovation is the loss of the original Latin verb *edere* ‘to eat,’ and its replacement by two distinct alternatives from the common Latin lexical stock. The act of replacement involved a semantic change in the replacing forms.

We know enough about the history of Romance to be able to recover the right answer in this case, and it is not obvious how one would use these data as subgrouping evidence otherwise. It might be objected that in “real” subgrouping, one has access to a large number of correspondences, and that this quantity of evidence affects the quality of the resulting argument. In other words: *the more numerous are the changes shared by a set of languages, the more likely that set is to be a subgroup*. For lexical data, this reasoning is valid. If we had 10 cases like the C/M case above, all distributed the same way, we would still not be able to distinguish the innovating subgroup from the remaining languages retaining the proto-forms. We might want to rule out (iii) (rightly or wrongly), on the grounds that 20 changes in two subgroups are less likely than 10 changes in one subgroup and 10 retentions. This reasoning may not be acceptable since, by the same token, one change and one retention is better than two changes. But we wouldn’t be that much farther ahead in any case.

I chose a lexical example to highlight the problem of identifying shared retentions. Sound correspondence data don’t fare particularly better. For sound correspondences, we can rule out the possibility of *both* forms being retentions, but the problem of distinguishing retention from innovation remains. Two sorts of argument are often used in such cases. One, exemplified in the hypothetical sound correspondence above, is that incorrect identification often leads to postulating unnatural changes. I won’t reiterate the difficulties associated with the notion “natural change,” except to note that this example was not entirely hypothetical, but is drawn from the correspondence set from which Proto-Micronesian *f has been reconstructed (see, for example, Jackson 1983: 352ff), and that the reconstruction entails the “unnatural” change *f > p in the Ponapeic languages.

The other is the quantitative argument noted above for lexical data, and it fares no better for sound changes. It might, however, be argued that the quantity of changes is some help in ruling out diffusion and independent innovation, from the premise that the more shared changes there are, the less likely they are to have diffused or arisen separately. However, the use of “more” in this subgrouping heuristic is problematic. Exactly how many shared changes does it take to make a subgroup? This question is not entirely a facetious one, if one considers a situation in which each of the subsets of the languages concerned shares some number of changes. Short of a “subgroup constant,” this heuristic seems to imply that subgroup membership is relative; that is, that we use a wave model of relatedness, rather than a family tree. And in that case, the subgrouping issue becomes moot.

What is perhaps the least problematic basis for subgrouping is also the least linguistically interesting, and that is geography. *A historical outcome shared by L_1*

and L_2 is more likely to be a shared retention if L_1 and L_2 are geographically distant, and more likely to be a shared innovation if they are adjacent. That heuristic has traditionally had a role in the hypothesis that identifies the locus of change with an “innovative core.” While the logic of the geographic premise appears faultless, you really don’t need to know much linguistics to subgroup on that basis.

I despair for the subgrouping enterprise, then, because good subgrouping evidence is very hard to find and motivated subgrouping argument forms virtually impossible. Given this bleak scenario, it is unfortunate that comparative historical linguists cannot restrict themselves to simple genetic arguments, and just ignore subgrouping. Many comparative linguistics view their principal goal not to be demonstrating genetic relatedness, but producing a complete genetic history for some language family, in the form of a tree. I do not suffer terribly myself from “Darwin envy,” but I am interested in using the comparative method to do realist reconstruction of aspects of the grammar of a proto-language. One cannot select a proto-phoneme or a proto-lexical item, in any but the most trivial cases, without some subgrouping assumptions.

Indeed, I make subgrouping assumptions in my own work, though not without at least a twinge of guilt, because those assumptions are often not well motivated, and may often not be justified. But maybe I’m being too hard on myself; as important as it is to know what can be done, it is equally important to appreciate what it might not be possible to do.

4 Some Concluding Thoughts on Subgrouping and Method

Any historical enterprise is by nature limited, since time leaves only a very imperfect trace of its passage for subsequent generations to read. Modern comparative historical linguists are perhaps luckier than practitioners of other historical disciplines, though. Linguistic theories may change, but the majority of linguists, unlike our earlier nineteenth-century progenitors, do not believe that the essential nature of language has changed over the timespan with which comparative historical linguistics deals. In that respect, we may still have more in common with geologists and geomorphologists than with sociopolitical historians, many of whom in the present intellectual climate appear to feel constrained (or liberated!) to interpret history only in a contemporary context.

And we have the comparative method, from which genetic conclusions can be inferred from evidence of acceptable quality. Practitioners of other historical disciplines, archeologists for example, envy us that method and are often led to seek guidance from us as a result, in the mistaken view that comparative historical linguists can answer many of the questions that archeology cannot. The shoe is less often on the other foot.

But historical linguistics is not the comparative method. Much can be done through internal reconstruction, or with techniques that have as a premise just

the demonstration of genetic relatedness, without either subgrouping or comparative reconstruction. Much historical grammar is done that way.

Subgrouping has always been, for me, the soft underbelly of comparative linguistics, for the reasons outlined above. Subgrouping is not only methodologically problematic, but factually so as well, since we know that changes diffuse through the linguistic landscape, and give rise to the patchwork of isoglosses rather than the discreteness of trees. The status of subgrouping in comparative linguistics is similar to that of regularity; it is in fact questionable but in practice necessary. Subgrouping is necessary not for genetic inferences themselves, as pointed out above, but for realist lexical reconstruction. This is so because the phonetic content one reconstructs is a function of subgrouping assumptions (and assumptions about subgrouping like those considered in section 3.4.2). Whether or not one is interested in homelands and migrations, or in any similar issues in general prehistory, one must subgroup in order to reconstruct.

In section 3.2 it was observed that, though sound change is not regular, given sufficient time depth it gives the appearance of regularity. The same may be true for subgrouping in that, with a sufficiently long period of relative homogeneity and/or contact, a set of shared innovations (or, at least, the *appearance* of a set of shared innovations) may arise. But the number of actual cases for which that is demonstrably the case does not appear to be as large as those in which time yields the appearance of regularity.

As a consequence, if we want to do realist lexical reconstruction, it is standard practice to make subgrouping *assumptions*. If the views on subgrouping elaborated here are in any sense deviations from this standard practice, it is only in recognizing that subgrouping arguments are very seldom more than assumptions. But there's no shame in that. It is a mature discipline that has evidential standards, and that recognizes its own limitations.

ACKNOWLEDGMENT

I would like to thank Alan Dench and Brian Joseph for comments on an earlier draft of this chapter and suggestions that I hope have improved this one. The usual disclaimers apply.

NOTES

- 1 For a detailed explication of the comparative method per se, see Rankin, this volume.
- 2 See Thomason, this volume, for discussion of this point.
- 3 An explanatory “retroductive” theory of change, one that tells us how language states could/must have arisen, is probably a chimera, given that particular changes do not,

in fact, *have* to happen. My point is only that, if we had such a theory, we wouldn't need the comparative method.

I might also note the existence, since the nineteenth century, of a partial theory constructed along these lines, and used in conjunction with, or as a preliminary to, the comparative method. I refer, of course, to *internal reconstruction* (see Ringe, this volume), the technique of synchronic morphophonemic analysis in its historical interpretation. Internal reconstruction tells us that synchronic morphophonemic alternation is the result of conditioned change applied to antecedent non-alternating forms. We need only infer the precise changes involved to undo the alternations and recover the antecedent state. It is, after all, a partial theory!

- 4 I myself am a realist as regards reconstruction from the comparative method, *pace* such criticisms as those in Lightfoot (1979). I believe that we can use the comparative method for reconstruction, and that such reconstructions have the status of best approximations to antecedent historical states.
- 5 I will refer to these systems as *languages*, rather than use some less sociolinguistically charged term like *lect*.
- 6 The term *genetically related* is frequently paraphrased as "sharing a period of common history." Though I am not above using that paraphrase myself, it is dangerously vague in that it covers both relations through a common ancestor and relations through diffusion/contact/borrowing. A paraphrase like "having a common ancestor" is, strictly speaking, more accurate.
- 7 This characterization of the major warrant for genetic inference in comparative linguistics is a modification of that given in Anttila (1972: 302).
- 8 Many linguists might be tempted to turn off at this point; such is the discomfort conjured up by the very mention of the word "semiotics" in polite linguistic company. Permit me a slight departure from convention in presenting a very short anecdote that serves to demonstrate the power of ideology in modern linguistics, and the strength of the prevailing ideology's disdain for anything connected with the term "semiotics."

Some years ago I had the opportunity to give a graduate course I titled "Historical Grammar" to about a dozen students in an American linguistics department. One of those students was a recent transfer from a quite prestigious east-coast linguistics department. He was taking the course under some duress, to prepare himself for the historical linguistics component of the Ph.D. qualifying exam. I began the course much as I've begun this chapter, with a discussion of the goals of comparative historical linguistics and of the nature and limitations of the comparative method, particularly as regards investigation of the history of non-lexico-phonological aspects of language. In the course of that discussion, lecture 2 I think it was, I introduced aspects of the semiotic theories of Charles Sanders Peirce, in an undisparaging manner. At that point, the aforementioned student rose and left the room, never to return. He didn't pass the historical linguistics section of the qualifying exam that semester either. I returned to Australia shortly thereafter, and

- have no idea of his subsequent history.
- 9 For a contemporary view of iconic linguistic signs, see Haiman (1985a, 1985b). Of course, no onomatopoeic form and no metaphor is purely iconic; all have some measure of conventionality about them. But few linguists, I think, would want to argue that the sign 'moo' is as arbitrary as the sign 'cow,' though I am prepared to listen to any such argument! Indexical signs, in the sense I have in mind (as distinct from that in which deixis is indexical), do not seem to be relevant to natural language.
 - 10 I will speak of genetic relatedness and cognacy as binary relations, but intend that the relations be generalizable to *n*-ary. I don't want to buy into the "binary comparison" issue (see DeLancey 1994a), except to say that I'm not convinced there's an issue.
 - 11 The emphasis on *prove* is deliberate; saying two objects are cognate, and proving that they are, is not the same thing.
 - 12 My choice of the indefinite article is deliberate, in allowing for the possibility of more than one reflex of the same antecedent object coexisting in a single language state. Possible examples are: French *le* 'the' and *le* 'him,' English *an* and *one*, or Spanish *muy* 'very' and *mucho* 'much'. And how does one talk about the relation between such items? Are they, for example, cognate?
 - 13 As observed, for example, by Thomason and Kaufman (1988), the sort of acquisition and change involved in the pidginization phenomenon is not "normal" in the intended sense.
 - 14 See the chapters by Bybee, Fortson, Heine, Hock, Joseph, Mithun, and Traugott in this volume for discussion, plus Janda (2001).
 - 15 That's not to say that such a theory is not heuristically useful; only that it's not necessary.
 - 16 This is the view of sound change suggested by Labov in published work as early as Labov (1972) and, more recently, in Labov (1994).
 - 17 A problem like that of multiple reflexes of the same historical segment is no worse for this view of cognacy than is the problem of multiple reflexes of the same lexical item, noted in n. 12.
 - 18 These issues were the subject of a thread of discussion begun by Fritz Newmeyer on 30 November 1994 (see Newmeyer 1994) and dealing with "the applicability of the comparative method to syntax." As is often the case in such discussions, there was some confusion regarding exactly what was, or should have been, at issue. Many of the contributors were concerned as much or more with the proper delimitation of the question as with the answer. Should the term "syntax" in this context refer just to constituent order, should it include category systems, paradigm structure, and so forth? However, I was particularly struck by the view put by Karl Teeter: "If one can include a section on syntax in a grammar, one can apply the comparative method in syntax" (Teeter 1994a). As my remarks above might suggest, I have seldom come upon a methodological assertion with which I disagree more. On the other hand, I have strong sympathy for his assertion that "when I do linguistic history I write a grammar of a protolanguage" (Teeter 1994d), if what he means is that one must aim at reconstructing a coherent

- fragment, however small, of a possible natural language.
- 19 This insight is made particularly salient in the fact that the same attribute-value matrix representations are used in HPSG for signs of all types.
- 20 One might be tempted to stress that sentences, and other syntactically complex signs, have information about their component parts. But the same is true of morphemes too; it's just that for the latter the information is "phonological," while for the former it is (more critical) "syntactic" information. I'll do my best to avoid that minefield here.
- 21 Such associations of grammatical form with meaning were long deprecated in "standard" generative grammar, it seems to me, as a consequence of Chomsky's strong insistence, in the past, on the "autonomy of syntax."
- 22 There is perhaps a paradox, not often noted, in the fact that some linguistic objects are reconstructible without counting as evidence of genetic relatedness. The limiting case for such objects is linguistic universals. If one believed, for example, that all languages have a categorial distinction between nouns and verbs, then one has licence to reconstruct that distinction in any proto-language. But since such reconstructions do not depend on evidence, or depend on evidence that holds equally over unrelated languages, it is of no value in determining genetic relatedness.
- 23 Any reference to the semiotic properties of syntagmatic objects is rare in the historical linguistic literature. An exception is Anttila (1972: 195), who points out that "rules are largely iconic," but does not elaborate.
- 24 I use the example of Greenbergian clause typologies because of its importance in the literature on word order change. Of course, the facts of word order are often more complex than can be accommodated by simple statements that, in *L*, transitive clause order is one particular permutation of *S*, *O*, and *V*. "Fixed word-order" languages often show more than one order of major constituents in transitive clauses, under grammatically well-defined conditions. Such observations have no direct bearing on the issues I raise here, but the same is not true of the problem of identifying subject and object in ergative languages. The universality of the subject and object relations is the core of the problem – see below.
- 25 Many languages admit a fourth possibility in the plural, in distinguishing those speaker-inclusive groups that include the hearer from those that don't.
- 26 Classical Arabic has distinct dual pronouns in the second and third persons masculine. The same was apparently true of Ugaritic (see Pardee 1997: 133–4), which had an additional distinct first dual suffixed pronoun as well. The only modern Semitic languages with dual pronouns are Eastern South Semitic languages like Mehri and Soqotri. These forms do not appear to be cognate with those of Classical Arabic, however.
- 27 See Ringe, this volume, for discussion of this method.
- 28 With more than a little justification, Brian Joseph (pers. comm.) objects that it is perhaps more accurate to describe Classical Latin as having had "free" word order. One could always consult the statistics on word order in the Classical Latin prose corpus to help decide whether or

- not OV was the unmarked order. I've not sought out those statistics, since I offer this example for illustrative purposes only.
- 29 Similar observations can be made regarding the English compound data. Brian Joseph (pers. comm.) points out that compounds like *pick-pocket* and *turn-key* are instances of a non-productive, and thus perhaps archaic, mechanism for forming verb-object compounds in VO order in English. It is the OV order that is productive.
- 30 In preparing drafts of a grammar of Gilbertese, I endeavored to construct just such an analysis, but ultimately gave up the attempt.
- 31 In my own linguistic area, Oceania, I might note the pioneering work of Pawley, of Clark, and of Chung on Polynesian articles, prepositions, and verb morphology, and some of my own efforts in Micronesia.
- 32 DeLancey makes the same point (1994b).
- 33 This same phenomenon is found as well in Hittite and in Vedic Sanskrit.
- 34 In a reply to Manaster Ramer, Valiquette (1994) suggests that the Iranian/Greek oddity might not be all that odd, but is a consequence of the generalization of a collective interpretation for neuter plurals. Since I'm not an Indo-Europeanist, I can't comment.
- 35 See Pawley and Green (1984: 139–42) for some discussion.
- 36 Rate of change may itself be the “problem” for the comparative method. If some language or set of languages changes very quickly, then it is that fact, rather than the absolute time since the onset of differentiation, that trips up the comparative method. A rapid rate of change may lead some language(s) to be underrepresented in reconstructions, as Grace (1985) suggests has been the case in the reconstruction of Proto-Austronesian and its descendants over the last century. Though I have felt personally slighted in the past because the Micronesian languages on which I was working were largely ignored in reconstructing Oceanic, on reflection it would seem that there is logic in putting greater emphasis on languages that (are believed to) have changed least. It is the same logic used when one puts greater emphasis on Greek and Sanskrit (or, perhaps, Icelandic and Lithuanian) than on Romanian and Afrikaans in reconstructing Proto-Indo-European (PIE).
- 37 I might note that the same problem had been recognized for the Micronesian languages. I was privileged to be part of a group at the University of Hawaii that applied the same logic to integrating Micronesian languages into Oceanic. In our case, however, the logic worked.
- 38 As Brian Joseph has reminded me (pers. comm.), Sihler (1995: 7) makes a similar point about the importance of shared innovations as opposed to shared retentions by means of an analogy, noting that subgrouping is rather like club membership: “Members of a club have something in common – they joined the club; but the people in the community who are not members of the club do not constitute a second de facto club.”

3 Internal Reconstruction

DON RINGE

“Internal reconstruction” (IR) is the exploitation of patterns in the synchronic grammar of a single language or dialect to recover information about its prehistory. The methods of IR are generally less reliable than the standard methods of comparative reconstruction (CR; see Rankin, this volume) for the following reasons.

Many of the changes that occur naturally in languages over time eliminate language structures in unrecoverable ways. These include the replacement of lexemes by completely different words (e.g., the replacement of Old English (OE) *sinwealt* by Middle English *round*); the syntactic merger or loss of grammatical categories (e.g., the merger of the dative and instrumental cases within the OE period, and the subsequent loss of the dative); the leveling of morphophonemic alternations (on which see further below); the unconditioned merger or loss of phonemes; and other, less common processes (see Hoenigswald 1960: 28–37, 90–1). CR circumvents the effects of these changes by adducing evidence from related languages or dialects in which the same changes have not occurred; IR has no comparably straightforward means of “undoing” the changes. In the absence of comparative evidence, IR must make use of several assumptions about which types of changes are most likely to have given rise to the synchronic patterns observed. Many of those assumptions are not problematic, but the only one that is completely reliable in every case is the fundamental observation on which CR is also based – namely, that sound change is overwhelmingly regular.

IR is therefore of limited use in historical linguistics; CR is so much more reliable that it is preferred whenever possible. But there are situations in which the linguist is not offered a choice, either because a language is not demonstrably related to any other, or because it has been developing in isolation from its nearest kin for so long that comparative work encounters massive practical difficulties. A firm grasp of the principles of IR is therefore an essential part of the historical linguist’s professional knowledge.

Like all methods of linguistic reconstruction, IR proceeds by making inferences about unobservable stages of a language’s development on the basis of what is known from the observed history of languages. Therefore one can best

gain an understanding of IR by studying, in light of the known principles of language change, linguistic patterns whose origin and development is already well understood. Most of this chapter will accordingly be devoted to discussion of relevant examples. Since the standard theoretical treatment of Hoenigswald (1960: 68–9, 99–111) can scarcely be bettered, I will concentrate on the practical problems that IR involves.

The structural patterns that are most useful for IR are alternations between (lexical) phonemes in morphological contexts. I shall first discuss and exemplify the exploitation of individual alternations, then consider other types of patterns that can be used in IR. For further discussion see now Fox (1995: 145–216).¹

1 Alternations Resulting from Conditioned Merger

IR most often exploits alternations resulting from the conditioned merger of phonemes, which is necessarily accompanied by split of one of the original phonemes (Hoenigswald 1960: 91–3); in Hoenigswald's maximally concise formulation:

phonemic SPLIT in several of its varieties leads to morphophonemic alternation, provided that morph boundaries fall between the conditioning and the conditioned phoneme or phonemes and provided that the same phoneme in the same morph thus comes within the range sometimes of one, sometimes of the other, type of conditioning phoneme or phonemes. (p. 100)

The type of conditioned merger that presents us with patterns of data most favorable to IR involves the neutralization of phonemic contrasts in easily recognized environments which occur often enough to provide numerous examples (cf. Hoenigswald 1960: 100–2). A straightforward case is the devoicing of word-final obstruents observable in (Standard) German.² Especially numerous are examples involving stem-final alveolar stops, of which the following partial noun paradigms are typical:³

<i>Singular</i>	<i>Plural</i>	<i>Meaning</i>
/ta:t/	/ta:tən/	'deed'
/p ^f a:t/	/p ^f a:də/	'path'
/gra:t/	/gra:də/	'degree, rank'
/gra:t/	/gra:tə/	'edge, ridge'
/špa:t/	/špa:tə/ ~ /špe:tə/	'spar' [mineral]
/ra:t/	/re:tə/	'council, councilor'
/ra:t/	/re:dər/	'wheel'

It is clear that the shape of the plural cannot be predicted from the shape of the singular; and one of the unpredictable details is whether the final /t/ of

the singular reappears in the plural or /d/ appears in its place. The same phenomenon occurs in the inflection of other classes of words which have endingless forms. For example, among adjectives one finds /bunt/ 'mottled' with inflected forms /buntə/, etc., but /gəzunt/ 'healthy,' /gəzundə/, etc.; among verbs one finds narrative preterite /zi: ri:t/ 'she advised' and /zi: ri:tən/ 'they advised,' but /zi: fermit/ 'she avoided' and /zi: fermitən/ 'they avoided.' Nor is the phenomenon restricted to these particular consonants; one also finds the alternation /-k/ ~ /-g-/ contrasting with invariant /k/ (/verk/ 'work,' pl. /verkə/ but /t^sverk/ 'dwarf,' pl. /t^svergə/, etc.), the alternation /-s/ ~ /-z-/ contrasting with invariant /s/, and so on.

Because this phenomenon occurs in the inflection of words of different morphological classes, its origin cannot plausibly be attributed to morphological change; after all, it is most unlikely that three or more *different* morphological changes would give precisely the same result. Because a large proportion of the language's basic vocabulary is involved, any explanation involving borrowing from another language⁴ is likewise implausible. Only sound change could reasonably have given rise to so pervasive a pattern, and the suspicion that sound change is responsible is confirmed by the details of the pattern: it involves a natural class of sounds, namely obstruents, in a clearly definable phonotactic position, namely at the ends of phonological words.

Once it is clear that sound change is responsible for the observed pattern, we can exploit the fact that sound change is overwhelmingly regular – that is, that the conditions which govern sound change are strictly phonological. If the stem-final consonant had originally been *t in all the forms adduced above and had become /-d-/ between vowels, we would be unable to explain why it had become /-d-/ in /p^fa:də/ 'paths' but not in /gra:tə/ 'ridges,' and so on, since no phonological conditioning for the difference can be stated. Therefore we must conclude that the paradigms in question were originally⁵ *ta:t, *ta:tən; *p^fa:d, *p^fa:də; *gra:d, *gra:də ('degree'); *gra:t, *gra:tə ('ridge'); and so on, and that the alternation between word-final /-t/ and non-final /-d-/ was created by a regular sound change which devoiced word-final obstruents (affecting also *-g, *-z, etc.; see above). The exceptionlessness of sound change is reflected in the exceptionlessness of the alternation, which is completely automatic: one simply does not find word-final /-d/, etc., in this variety of German.

Since this is a maximally simple example with which further examples will be compared, it is worth noting a number of additional facts about it. Because the alternation between voiced and voiceless obstruents is fully automatic, it remains fully transparent to the native speaker: a theory of phonology which permits any abstraction from surface contrasts at all will analyze the alternation /-t/ ~ /-d-/ simply as /d/, and in fact that is the analysis reflected in Standard German spelling (*Pfad*, *Pfade*, etc.). In such a simple case IR replicates phonological analysis point for point, and the reconstruction of the earlier state of affairs is achieved simply by deleting a single phonological rule from the grammar.

Yet even in such a straightforward example, not every detail of our reconstruction is historically accurate. For instance, IR fails to tell us that *Grad* ‘degree,’ unlike the other nouns listed above, was borrowed into German well after the devoicing of word-final obstruents occurred.⁶ That *Grad* should nevertheless exhibit the alternation is scarcely surprising: once devoicing of word-final obstruents had become an exceptionless, “surfacey” phonological rule, every new loanword ending in a voiced obstruent would have become subject to it automatically. But it should be clear that the chronological relationship between the acquisition of new lexemes and the acquisition of postlexical phonological rules will not, in general, be recoverable by IR, since it is the nature of such rules to apply to any and all lexemes regardless of their origins.

Another detail which IR cannot recover is the original identity of non-alternating phonemes in the position of neutralization; for example, IR will not tell us whether the final stop of the invariant particle /unt/ ‘and’ was originally *t or *d. A related problem involves lexemes that ought to exhibit the alternation but are seldom used in the form(s) in which the neutralization failed to occur. For example, the Old High German noun ‘value, worth’ and adjective ‘valuable, worth’ were both *werd*, and one might expect that the modern words would be “/vert/ ~ /verd-/,” with underlying //d//; but in fact we find invariant /vert/, /vert-/, with underlying //t//. Apparently the unsuffixed form, which was affected by the regular devoicing of word-final obstruents, was so much commoner (or more salient) than all the inflected forms together that its surface /-t/ was reanalyzed as underlying /t/ by some past generation of German speakers. Since the result is a non-alternating paradigm, IR cannot recover this sequence of events; instead we are led to reconstruct a historically inaccurate *vert, *vert-.

This last type of development is among those traditionally called “analogical changes” – in effect, changes that depend (at least in part) on morphological structure,⁷ as opposed to sound changes, which are strictly phonetic or (low-level) phonological. Both types of change, occurring subsequently to a given sound change that gave rise to a given alternation, can increase the difficulty of IR from that alternation in a variety of ways. Two cases that illustrate these processes are the fronting of *a: in the Attic dialect of Ancient Greek and the rhotacism of intervocalic *s in early Latin.

The historical changes that affected *a: in Attic Greek were not simple (see Szemerényi 1968; Gates 1976), but the net result of the changes was a straightforward alternation: original *a: appears as /ε:/ (merging with original /ε:/) except when preceded by /i/, /e/, or /r/, in which positions it remains as /a:/. The distribution of /a:/ and /ε:/ is quite clear, and the alternation between them is pervasive in Attic Greek morphology; it appears in the singular endings of hundreds of “first declension” nouns and adjectives, in the sigmatic aorists of verbs with roots ending in resonants (Smyth 1956: 173), in a small class of very common verb stems (“mi-verbs”; Smyth 1956: 134–9), and so on. This wide distribution makes it clear that the alternation is the result of a sound change. Both /ε:/ and /a:/ appear without restriction after front vowels

and /r/, but examples of /a:/ not after a front vowel or /r/ are usually explainable as more recent developments (see below); the principle that sound changes are regular therefore leads us to reconstruct this change as “*a: > /ɛ:/ except after /i, e, r/.”⁸ The merger of *a: and *ɛ: occurred in so many phonological environments that it is sometimes not clear from internal evidence which older sound a given instance of /ɛ:/ reflects simply because it does not happen to occur after /i/, /e/, or /r/. That *a: was the original sound is sometimes shown by the fact that /ɛ:/ alternates with short /a/ (the latter appearing, for example, in the plural endings of first declension nouns and adjectives), while original /ɛ:/ alternates with short /e/. Compare the following partial paradigms of some Attic Greek verbs:

/apédra:/	/éste:/	/ésbe:/
‘(s)he ran away’	‘(s)he stood up’	‘it [the fire] went out’
/apodrâ:nai/	/stê:nai/	/sbê:nai/
‘to run away’	‘to stand up’	‘to be extinguished’
/apodraîc:/	/staïc:/	/sbeïc:/
‘let him/her run away’	‘let him/her stand up’	‘let it go out’
/apodrântes/	/stântes/	/sbéntes/ ‘(upon)
‘(upon) running away	‘(upon) standing up	being extinguished
(nom.pl.masc.)’	(nom.pl.m.)’	(nom.pl.m.)’

Note that in the third and fourth form given for each verb the vowel after the /r/, /t/, or /b/ respectively appears shortened, and ‘stand up’ shows /a/, like ‘run away’ but unlike ‘be extinguished’ – showing that the /ɛ:/ of /éste:/ and /stê:nai/ was originally *a:.

This clear pattern has been complicated by a considerable number of subsequent changes, but not all have been equally disruptive. Many new /a:/'s have arisen by two later sound changes, vowel contraction and the “second compensatory lengthening” (2CL); however, those changes also gave rise to alternations from which the original state of affairs is still recoverable, and for that reason they do not seriously obscure the /a:/ ~ /ɛ:/ alternation. For example, compare forms of the present tense of /tolmâ:n/ ‘dare’ with the corresponding forms of /p^hére:n/ ‘be carrying’:

/tolmâ:men/ ‘we dare’	/p ^h éromen/ ‘we are carrying’
/tolmâ:te/ ‘you (pl.) dare’	/p ^h érete/ ‘you (pl.) are carrying’

The paradigms differ in two ways. In the first place, if we consider the vowels between the invariant root-syllables /tolm-/ , /p^her-/ and the invariant endings /-men/, /-te/, it is clear that the vowels found in ‘dare’ are both longer and lower than the corresponding vowels of ‘be carrying’, but that they resemble the latter to some extent (‘we...’ always shows a back round vowel, for example). Second, the accent falls on the third syllable from the end of the word in ‘be carrying,’ but on the second syllable from the end in ‘dare.’ When

we consider also the fact that there is a noun /tólma/ ‘courage’ obviously related to ‘dare,’ it becomes clear that the most plausible and economical way to account for all these phenomena is to posit earlier forms *tolmáomen for /tolmâ:men/ and *tolmáete for /tolmâ:te/. The /a:/ of the latter form, then, resulted from contraction of the sequence *ae; and because we can explain its appearance by such a development, it does not seriously obscure the pattern according to which we expect /a:/ after /i, e, r/ but /ɛ:/ elsewhere – a pattern which, we now see, applies only to those older (“original”) instances of *a: which existed before vowel contraction had occurred. In fact, the larger pattern now permits us to reconstruct the relative chronology of the sound changes involved: the change “*a: > /ɛ:/ except after /i, e, r/” must have run its course before the change “*ae > /a:/” produced new /a:/’s, since those new /a:/’s did not undergo the former change.⁹

The 2CL can likewise be recovered from the patterns of alternation to which it gave rise. Consider the following partial noun and adjective paradigms:

	‘guard’	‘serf’	‘black’	‘(upon) standing up’
nom.sg.masc.	/p ^h úlaks/	/t ^h é:s/	/méla:s/	/stá:s/
nom.pl.masc.	/p ^h úlakes/	/t ^h é:tes/	/mélanes/	/stántes/

The invariant endings are nom.sg. /-s/ and nom.pl. /-es/, and the stem of ‘guard’ is likewise invariant /p^húlak-;/ but the other stems participate in various alternations. The stem of ‘serf’ appears as /t^hé:t-/¹⁰ when a vowel follows, but as /t^hé:-/ when followed by /-s/; and since fuller study of the grammar shows that /-t-/ was not normally inserted between vowels in Greek, we must conclude that the nom.sg. was originally *t^hé:ts, and that stem-final *-t- was lost when *-s followed immediately. By a similar line of reasoning we conclude that the nom.sg.masc. of ‘black’ was originally *mélans, and that the sequence *ans became /a:s/ by the 2CL. Finally, in the nom.sg.masc. of the participle of ‘stand up’ both changes have occurred – first the loss of *-t-, then the 2CL – and the development can be reconstructed as *stántes > *stáns > /stá:s/. This accounts for numerous additional cases of unexpected /a:/; and of course the fronting of *a: must likewise have run its course before the 2CL occurred.

One would expect greater disruption to have resulted from changes that tended to obscure the /a:/ ~ /ɛ:/ alternation *and are not reconstructible*. For example, already in the sixth century BCE, Attic possessed two noun stems which obviously belong in the first declension¹¹ but show stem-final /ɛ:/ < *a: after /r/, /kóre:/ ‘girl’ and /dére:/ ‘necklace.’ Comparative evidence from other dialects shows that these words originally had a *w before the stem-final vowel (cf. Arkadian <korwa>¹² ‘Persephone’, <derwa> ‘ridge, spur (of a hill)’), and it is reasonable to infer that the *w had not yet been lost in Attic when the fronting of *a: occurred (so that the *a: was not then immediately preceded by *r); but since *w was subsequently lost without a trace in Attic, IR cannot recover those events. A similar case is /kórre:/ ‘temple (of the head):’

comparative evidence shows that /kórre:/ < *kórse: (preserved unchanged in East Ionic) < *kór̥sa: (preserved unchanged in East Aiolic), but that development could not be recovered from Attic evidence alone. Still other cases of the same sort are Attic /póa:/ 'grass' < *poía: and /stoá:/ 'colonnade' < *stoiá: (both preserved unchanged in Doric dialects). At least one analogical change contributes further examples. A coherent class of pairs of present and aorist stems show the expected pattern pres. /-áine:n/, aor. /-â:nai/ ~ /-ê:nai/, the vowel alternation in the aorist stem depending on the preceding sound:

<i>Present</i>	<i>Aorist</i>
/hũgiaíne:n/ 'be well'	/hũgiâ:nai/ 'get well'
/ksɛ:raíne:n/ 'be drying (it) out'	/ksɛ:râ:nai/ 'dry (it) out'
/p ^h áine:n/ 'show (continually)'	/p ^h ê:nai/ 'show'
/sɛ:maíne:n/ 'indicate (continually)'	/sɛ:mê:nai/ 'indicate'
/ksaíne:n/ 'scratch (repeatedly)'	/ksê:nai/ 'scratch (once)'
/k ^h alepaíne:n/ 'be offended'	/k ^h alepê:nai/ 'take offense'

and so on (the list could be extended considerably). But toward the end of the fifth century BCE we find a few aorists with /a:/ not after /i, e, r/:

<i>Present</i>	<i>Aorist</i>
/koilaíne:n/ 'be hollowing out'	/koilâ:nai/ 'hollow out' (Thucydides 100.4.2)
/kerdaíne:n/ 'gain'	/kerdâ:nai/ 'make a profit' (Andocides 1.134; ¹³ Xenophon, <i>Apology of Socrates</i> 9)

The /a:/ of these aorists can only be the result of analogy with other aorists in which /a:/ is etymologically justified (though exactly which verbs provided the model for the analogical change is not clear).

But all these exceptions together do not suffice to obscure the pattern from which the fronting of original long *a: can be reconstructed internally, for a simple reason: there are hundreds of forms which show the expected alternation, and very few which fail to show it. In most cases IR can only identify these exceptional forms, not explain why they fail to behave as expected; and it should also be obvious that IR cannot tell us whether non-alternating /ɛ:/s are original or reflect original *a:'s.¹⁴ But none of these limitations is severe enough to render the reconstruction of the sound change "a: > /ɛ:/ except after /i, e, r/" problematic, and a large majority of the surviving examples of that sound change can still be identified.

The pattern of accidents that has affected Latin rhotacism, is quite different. The sound change in question was originally very simple: *s became /r/ between vowels, merging with inherited *r in that position;¹⁵ and that change is reconstructible by exactly the same sorts of arguments adduced to reconstruct the fronting of *a: in Attic Greek. In this case, however, the resulting alternation has been obscured by numerous factors, and IR consequently has less material with which to work.

One might expect that the regular change of *ss to /s/ after long vowels and diphthongs, which created new intervocalic /s/'s, would have made the alternation /s/ ~ /-r-/ opaque; but in fact little disruption seems to have resulted from this subsequent change, because *ss usually appeared in positions where one would expect to find consonant clusters on morphological grounds. Typical examples can be found in the perfect stems, participles, and supines¹⁶ of verbs with roots ending in /t/ or /d/:

<i>Present infinitive</i>	<i>Perfect infinitive</i>	<i>Supine</i>
/kwatere/ 'shake'	/kwassisse/ 'have shaken'	/kwassum/ '(so as) to shake'
/tru:dere/ 'push'	/tru:sisse/ 'have pushed'	/tru:sum/ '(so as) to push'
/laedere/ 'harm'	/laesisse/ 'have harmed'	/laesum/ '(so as) to harm'
/sede:re/ 'sit'	(/se:disse/ 'have sat')	/sessum/ '(so as) to sit'

The perfect stem /kwass-/ is patently underlying //kwat-s-//, parallel to /di:k-s-/ 'have said' (pres.inf. /di:kere/ 'say'); consequently one is led to posit something more than intervocalic /-s-/ in /tru:s-/ and /laes-/ not only by phonological comparison with /kwass-/, but also by the fact that they should be underlying //tru:d-s-// and //laed-s-//.¹⁷

In noun inflection similar arguments from morphology are not available, but stem-final *ss was very rare. The only clear examples are nom.sg. /oss/ 'bone', nom.pl. /ossa/; nom.sg. /wa:s/ (*wa:ss) 'container,' nom.pl. /wa:sa/ (still /wa:ssa/ in Plautus); nom.sg. /ass/ 'farthing,' nom.pl. /asse:s/, and compounds of the latter; and it is only in the second of these stems that *ss was reduced to /s/ after a long vocalic nucleus. But it is precisely in noun inflection that most examples of /s/ ~ /-r-/ occur.

Nouns with stems originally ending in *s would be expected to exhibit /-s/ in the nominative singular (and the accusative singular, if their gender was neuter), but /-r-/ in all other forms (since stem-final *s was flanked by vowels in those forms). Monosyllabic noun stems preserve this alternation faithfully: thus we find nom.sg. /flo:s/ 'flower' (masc.), nom.pl. /flo:re:s/; nom.sg. /o:s/ 'mouth' (neut.), nom.pl. /o:ra/; etc. But while some polysyllabic stems (such as nom.sg. /tellu:s/ 'earth' (fem.), acc.sg. /tellu:rem/) also preserve the alternation, most masculines and feminines have levelled stem-final /-r-/ into the nom.sg.; thus, while we still find nom.sg. /arbo:s/ (fem.) 'tree' occasionally in poetry (e.g., Vergil, *Georgics* 2.66), the normal nom.sg. is /arbor/ (cf. nom.pl. /arbore:s/, etc.), and while Cicero still used nom.sg. /hono:s/ (masc.) 'public office, distinction,' later generations used /honor/ (cf. nom.pl. /hono:re:s/, etc.).¹⁸ This analogical change completely obliterated the alternation in question; moreover, in doing so it transferred old s-stems into a very large class of stems already in existence, namely r-stems like nom.sg. /praetor/ (masc.) 'chief judicial magistrate' (nom.pl. /praeto:re:s/, etc.). If we did not have occasional older nom.sg. forms in /-s/, we would not be able to recognize these nouns as s-stems. To a considerable extent, then, the analogical levelling of /-s/ ~ /-r-/ to invariant /r/ makes these former examples of the alternation inaccessible to IR.

Most polysyllabic neuter s-stems have not levelled /-r-/ into the nom.sg.; but they do not provide as much support for the alternation as one might expect. A principal difficulty here is that all the relevant nouns exhibit short vowels before the stem-final /-s/, and short vowels in non-initial syllables underwent drastic changes in the prehistory of Latin. Only after one realizes that word-final /-us/ can reflect either *-us or *-os does it become possible to reconstruct nom.sg. /tempus/ (neut.) 'time,' nom.pl. /tempora/ as invariant *tempos(-); thus the plausibility of IR of *s here depends to some extent on prior IR of an adjacent segment. In the class represented by nom.sg. /genus/ (neut.) 'kind,' nom.pl. /genera/, the vowel alternation is scarcely amenable to IR at all. But why, one might ask, can we not reconstruct the original stemfinal consonant without worrying about the preceding vowel? Of course we can, but other relevant facts about the grammar of Latin might lead us to be cautious. In particular, the shape of a noun stem that appears in the nom.sg. and the stem-shape that appears in other forms sometimes show differences that are not obviously the results of sound change. Presented with such pairs as nom.sg. /homo:/ (masc.) 'human being,' oblique stem /homin-/, and nom.sg. /iter/ (neut.) 'way, journey,' oblique stem /itiner-/, one might not want to reject out of hand the possibility that the difference between nom.sg. /genus/ and its oblique stem /gener-/ reflects something other than regular sound change.¹⁹

Nor does verb inflection offer the linguist much assistance in this case. Few verb roots exhibit a clear /s/ ~ /-r-/ alternation; the following list of more or less regular verbs is, I think, exhaustive:

<i>Present infinitive</i>	<i>Perfect infinitive</i>	<i>Supine</i>
/gerere/ 'bear'	/gessisse/ 'have borne'	/gestum/ '(so as) to bear'
/u:rere/ 'burn (it)'	/ussisse/ 'have burned (it)'	/ustum/ '(so as) to burn (it)'
/haere:re/ 'cling'	/haesisse/ 'have clung'	/haesum/ '(so as) to cling'
/hauri:re/	/hausisse/	/haustum/
'draw (water)'	'have drawn (water)'	'(so as) to draw (water)'
/kwaerere/ 'seek'	/kwaesi:wisse/	/kwaesi:tum/
	'have sought'	'(so as) to seek' (but cf. also
		/kwaestio:/ 'inquiry')
/kweri:/	/kwestus esse/	
'complain'	'have complained'	

(Note that some of these paradigms provide further examples of /s/ < *ss.) Even in the most perspicuous paradigms – those of /gerere/ and /kweri:/, in which *ges- and *kwes- are relatively easy to recognize – it is not immediately obvious that we are observing the results of regular sound change alone, since similar examples in which sound change cannot account for all the alternations can be found (cf. /premere/ 'press,' /pressisse/ 'have pressed,' /pressum/ '(so as) to press,' in which /ss/ apparently cannot reflect an earlier consonant cluster containing *m). There is one other verb root that ended in *s, namely *es- 'be'; but its inflection is so irregular that the alternation /s/ ~ /-r-/ can be extracted from it only with some caution.²⁰

In spite of all these difficulties, the Latin rhotacism of intervocalic *s is still accessible to IR; but reconstruction is considerably more laborious and involved in this case than in the case of the Attic fronting of *a:, and far fewer of the original examples are recoverable. The relative usefulness of these two sound changes in pedagogy is instructive. Whereas awareness of the alternation /a:/ ~ /ɛ:/ makes Attic Greek easier for the beginner to learn, awareness of rhotacism in Latin is of little use to the beginner; it is an extra fact to be memorized, and it does not appreciably decrease the amount of subsequent memorization necessary. Elementary Greek and Latin textbooks reflect this difference clearly.

The relative obscurity of the Latin alternation /s/ ~ /-r-/ is partly the result of subsequent changes, especially the generalization of stem-final /r/ in noun stems. However, it is also clear that IR is hindered by the fact that the scope of this alternation in the grammar of Latin was fairly narrow (being weakly represented in verb inflection, for example).

In sum, the feasibility of IR from any particular alternation depends on that alternation's salience and perspicuousness in the grammar. Any factor which obscures the alternation will tend to inhibit IR.

2 Alternations Resulting from "Secondary Split"

IR meets its severest challenges in attempting to reconstruct from "secondary phonemic split," in which an allophonic split occurs and the conditioning for the allophones is subsequently lost (Hoenigswald 1960: 93-5, 102-4, critiqued in Janda, this volume). In these cases IR must make assumptions about the phonetic naturalness of sound changes, and must posit sequences of changes, which may not be demonstrably correct. IR from secondary split is consequently much more speculative than in the cases discussed above.

A simple example is provided by sets of noun plurals in English. Some nouns ending in /f/ form the plural simply by adding /-s/, and those ending in /v/ likewise form plurals in /-z/:

<i>Singular</i>	<i>Plural</i>	<i>Meaning</i>
/riyf/	/riyfs/	'reef'
/fayf/	/fayfs/	'fife'
/owf/	/owfs/	'oaf'
/sərf/	/sərfs/	'serf'
/gəlf/	/gəlfs/	'gulf'
/sliyv/	/sliyvz/	'sleeve'
/fayv/	/fayvz/	'five'
/stowv/	/stowvz/	'stove'
/nərv/	/nərvz/	'nerve'
/vælv/	/vælvz/	'valve'

But we also find almost twenty nouns in /f/ that have plurals in /-v-z/, such as the following:

<i>Singular</i>	<i>Plural</i>	<i>Meaning</i>
/liyf/	/liyvz/	'leaf'
/nayf/	/nayvz/	'knife'
/lowf/	/lowvz/	'loaf'
/skarf/	/skarvz/	'scarf'
/wulf/	/wulvz/	'wolf'

The first problem for IR is the fact that this group contrasts with *both* the others. The only way we could reconstruct all three groups for any earlier stage of English in which all these nouns had invariant stems would be to posit a period in which the language possessed *three* labiodental fricatives (*f, *v, and perhaps a fricative intermediate between them) or in which the ancestor of alternating /f/ ~ /v/ was some quite different sound (say, bilabial *β). But most linguists would strongly disfavor both those alternatives, not because either is impossible, but because the first is phonologically unlikely – few if any languages exhibit three degrees of voicing in fricatives – while the second forces us to posit unlikely sound changes (for example, *β must not only have become labiodental – which would be unremarkable – but must also have become voiceless word-finally while the word-final fricative cluster *-βz remained voiced, which would be a relatively unnatural pattern of changes). Those are good arguments, and in this case we know they are correct because we know the history of these paradigms; but strictly speaking, we are already making unprovable assumptions about the probable development of the language, and our results will be correspondingly less certain in the absence of external verification (through CR or historical records).

It follows that no more than two of the above paradigms can reflect a significantly different earlier stage at which all the relevant noun stems were invariant. To determine which paradigms are (in that sense) “old,” we invoke a second assumption: paradigms which are irregular in terms of a language’s current grammar are likely to be inherited, reflecting the regular grammar of an earlier period. This assumption is by no means water-tight, and counterexamples can be found without too much difficulty; for example, the verb ‘go’ is suppletive in modern Romance languages (cf. French *aller* ‘to go,’ *va* ‘goes,’ *ira* ‘will go,’ etc.: three completely different roots in all) but not in Latin (*ire* ‘to go,’ *it* ‘(s)he goes,’ *eunt* ‘they go,’ *ibit* ‘(s)he will go,’ *iit* ‘(s)he went,’ *itum* ‘(so as) to go,’ etc., all from a root /i:-/ ~ /i-/ ~ /e-/). But it is *generally* true that irregularities are old, especially if they involve morphophonemic alternations (as is the case here). We hypothesize, then, that the class including /liyf/, pl. /liyvz/ reflects an inherited paradigm in which the stems were once invariant, whereas one or both of the other classes are later innovations of some sort.

Now we need to provide an explanation for the alternation /f/ ~ /v/. It cannot be conditioned by the plural ending in its current form, which is /-s/ ~

/-z/ ~ /-əz/ – the last alternant appearing after stem-final strident consonants,²¹ the first after other voiceless consonants, and the alternant /-z/ elsewhere. But we should suspect that the plural ending, too, was once invariant; that is one of the most plausible assumptions available to us (even if it is not quite as well grounded as the expectation of invariant lexical stems). We can then construct at least two plausible hypotheses about why /liyvz/ and the like exhibit stem-final voiced consonants in the plural.

If the ending were originally invariant *-s, there is no reason why the plural of /liyf/ should not be */liyfs/"; but what if it had been invariant *-z? In that case the final consonant cluster of an earlier plural *liyfz, for example, might simply have undergone regressive voicing assimilation to /liyvz/; and this will account for the entire class of nouns showing the stem-final alternation /f/ ~ /v/ (as well as the parallel class showing /θ/ ~ /ð/, e.g., /mawθ/ 'mouth,' pl. /mauðz/).²² It will then follow that such plurals as /riyfs/ 'reefs' must have been formed after the regressive voicing assimilation rule had run its course: either they have replaced older plurals with /-vz/ (or of another type, e.g., with the ending /-ən/), or English did not yet possess those nouns when the regressive voicing assimilation rule was still operating (or at least they did not then form plurals).²³

This is a very plausible hypothesis so far as it goes, but it still includes one dubious postulate: an obstruent cluster such as *-fz, with the constituent segments disagreeing in voicing, is not very likely to have remained unaltered for a long period of time (especially since it is not "supported" by vowels on both sides). Probably we should therefore make a further assumption that those consonants were brought into contact relatively shortly before any voicing assimilation took place; and the most likely development that would have given such a result is loss of an intervening vowel. Let us suggest, then, that the earliest reconstructable form of the plural ending was actually syllabic *-əz, which was preserved after a strident consonant but otherwise underwent syncope to *-z, after which voicing assimilations of various kinds occurred (see above with n. 23).

But once we have reached that point, another – and very different – explanation for the stem-final voicing in /liyvz/, etc. becomes possible. In most of the relevant cases the stem-final fricative would have been between vowels in the plural, and in all the rest it would have been between a sonorant (*r or *l, e.g., in the pre-forms of *scarves*, *wolves*) and a vowel – all of which are voiced sounds. Possibly what happened was a voicing of fricatives in voiced surroundings, the developments being approximately as follows:

*liyf, *liyfəz > *liyf, *liyvəz > /liyf/, /liyvz/

*nayf, *nayfəz > *nayf, *nayvəz > /nayf/, /nayvz/

*lowf, *lowfəz > *lowf, *lowvəz > /lowf/, /lowvz/

*skarf, *skarfəz > *skarf, *skarvəz > /skarf/, /skarvz/

*wulf, *wulfəz > *wulf, *wulvəz > /wulf/, /wulvz/

As before, it follows that plurals like /riyfs/ must be relatively recent innovations. This is a reasonable approximation of what actually happened; for example, the relevant Old English forms of 'wolf' were in fact /wulf/, /wulfas/.²⁴

In this case, then, IR from the results of secondary phonemic split is spectacularly successful; but even if our hypotheses have not been rendered tendentious by the fact that we happen to know the correct answer from historical records (as is all too likely!), sheer luck is a major factor in this success. The final conclusion rests on at least four unverifiable assumptions – perhaps as many as seven, depending on how one counts them. Though all those assumptions are plausible, any one of them might have turned out to be wrong in this particular case. Moreover, even if every assumption has a high probability of being correct, say 95 percent, the probability that they are *all* correct in this case is only $.95^4 = .8145$ if we consider ourselves to have made four unprovable assumptions, and $.95^7 = .6983$ if we have made seven. In other words, even if we stand only one chance in 20 of being wrong on any one point, we run at least about a one-in-five risk that our final conclusion does not reflect what really happened, and perhaps as great a risk as one in three. This demonstrates graphically where the greatest weakness of IR lies.

A sequence of changes one of which is a secondary phonemic split can render IR virtually impossible; a case in point is the alternation of /n/ and /š/ in Ojibwa. Proto-Algonquian (PA), a solidly reconstructable ancestor of Ojibwa, exhibited a regular alternation of *θ²⁵ and *š: the latter appeared before all high front vocalics (i.e., *y, *i, and *ii), while the former appeared in all other positions (Bloomfield 1946: 92). Since *š also occurred in other positions, while *θ never occurred before high front vocalics, IR from this pattern is straightforward: pre-PA *θ must have become *š before high front vocalics by regular sound change. In a large number of Algonquian languages, including the ancestor of Ojibwa, *θ then merged with *i; the immediate result was a situation in which some *i's alternated with *š whereas others did not:

<i>Proto-Algonquian</i>		<i>Pre-Ojibwa/Mesquakie/etc.</i>
*miikaaθeewa 'he fights' ²⁶	>	*miikaaleewa
*miikaaši 'fight him!'	>	*miikaaši
*miileewa 'he gives it'	>	*miileewa
*miili 'give it to him!'	>	*miili

A subset of these languages, again including pre-Ojibwa, resolved the opacity of this system by extending the alternation *i ~ *š to those forms which were originally invariant, so that (for example) *miili → *miiši (Bloomfield 1946). Then a further merger of *i with *n occurred, and the alternation again became non-automatic: some /n/'s, namely those reflecting older *i (which in part reflected still older *θ) alternated with /š/, while other /n/'s, namely those reflecting older *n, did not. This is part of the situation we find in Ojibwa as it was described by Bloomfield in the 1930s (Bloomfield 1956: 18).

But Ojibwa has also undergone a further change: PA *i, which was one of the conditioning factors for the original change of *θ to *š, has merged with

PA *e, before which *θ remained unchanged in PA.²⁷ Thus not only do some /n/'s alternate with /š/ while others do not; even those that do participate in the alternation do so before some /i/'s (namely those that reflect PA *i) but not others (namely those that reflect PA *e). Bloomfield knew the history of this case (through CR of Algonquian) in great detail, but he was at pains not to allow that knowledge to influence his description of Ojibwa, and the analysis he eventually settled on is interesting. As it happens, a large majority of examples of Ojibwa /n/ ~ /š/ involve PA elements ending in *θ or *l before PA endings of the shape *-i or a "connective" vowel *-i- (Bloomfield 1946: 90–1, 99 (§39), 100 (§43)). In his morphophonemic analysis of Ojibwa Bloomfield sets up an underlying consonant //N//, distinct from //n//, that reflects those PA *θ or *l whose reflexes still alternate with /š/ in Ojibwa; but he analyzes the conditioning environment for the alternation as /y/, setting up endings //-yi// and a connective vowel //-yi// (Bloomfield 1956: 17, 25). Given that PA *i and *e have merged in Ojibwa, this would seem to be the most reasonable way to account for the consonant alternation (since //N// does appear as /š/ before clear instances of /y/); it would also be the most reasonable IR from the data. Yet as a synchronic description it actually does not work very well, and as IR it clearly gives the wrong results. In particular, Bloomfield has to specify that the sequence //yi// preceded by a morpheme boundary behaves differently from the same sequence not preceded by such a boundary, in that it does not surface as /i:/ (1956: 19, §§3.26, 3.30); also, there are a few cases in which an element that cannot be analyzed as //yi// does trigger the alternation (1956: 18, §3.23). This is less of a problem for IR, because the historical linguist expects to find irregularities that reflect an earlier state of affairs that is only partly recoverable; but it is very doubtful whether IR alone could recover the merger of *i and *e in Ojibwa, which is the correct solution to the problem. In this case, then, the pattern of changes has rendered IR infeasible.

3 Reconstruction from Broader Patterns

Finally, it is possible to use as a basis of IR not only individual alternations, but patterns of alternations that perform the same grammatical function. Perhaps the clearest example of this procedure is its application to the first three classes of Germanic "strong" verbs.

Consider the following partial paradigms of Proto-Germanic strong verbs, which are uncontroversially reconstructible from their reflexes in Gothic, Old Norse, Old English, and Old High German:

<i>Present infinitive</i>	<i>Preterite 3sg.</i>	<i>Preterite 3pl.</i>
*bi:tanã 'to bite'	*bait '(s)he bit'	*bitun 'they bit'
*beudanã 'to order'	*baud '(s)he ordered'	*budun 'they ordered'
*bindanã 'to tie'	*band '(s)he tied'	*bundun 'they tied'
*werpanã 'to throw'	*warp '(s)he threw'	*wurpun 'they threw'

A general parallelism between these paradigms is immediately obvious. In fact, in the pret.3sg. the parallel is exact: every pret.3sg. conforms to the template CaRC, where C represents any consonant (so far as we can tell from these limited data) and R represents a high vowel or resonant (i.e., a sound less sonorous than a low or mid vowel, but more sonorous than any fricative, affricate, or oral stop – a natural class of sounds which shows parallel morphophonemic behavior in the grammars of many languages). Let us make the assumption that such an exact parallelism also existed in the other forms of these paradigms at an earlier period; that assumption can then form the basis for IR on these data.

In the present stem this leads us to propose (i) that the *i: of *bi:tanā is structurally *ii, and (ii) that the first element of the sequences *ii and *in (in *bindanā) was originally identical with the first element in the sequences *eu and *er. This is plausible because both *i and *e are short front vowels; and it is most economical to suppose that the earlier sound in question was likewise a short front vowel, though its phonetic identity is not recoverable from the data at hand. Representing it by *E, we can say that the pattern of vowels and resonants in present stems and 3sg. preterites is perfectly parallel:

*Ei ~ *ai = *Eu ~ *au = *En ~ *an = *Er ~ *ar;

in fact, these are all instances of *E ~ *a, the other element in the nucleus of each root being invariant.

The 3pl. preterites exhibit a more interesting pattern. On the basis of the first two examples, which show an alternation:

*E ~ *a ~ Ø (that is, *Ei ~ *ai ~ *i = *Eu ~ *au ~ *u),

we can reconstruct the 3pl. preterites of the last two examples as *bndun and *wrpun, with no vowel in the root – the resonant between consonants presumably having been syllabic. The Proto-Germanic *u that we actually find in the roots of these forms (which is unambiguously reconstructable by the application of CR to the attested languages) must then have developed by a regular sound change, reconstructable as *R₀ > *uR (i.e., syllabic resonants developed a u-vowel to their left). Comparative evidence from further afield, notably from Sanskrit, shows that this is in fact the correct conclusion.

But in this case, too, the claims of success for IR must be qualified, and once again the main weakness is in the assumptions made – notably in the assumption that the paradigms in question must have been morphophonemically parallel. To see the weakness of that assumption we need only adduce the corresponding forms of two further verbs:

Present infinitive
*beranā 'to carry'
*gebanā 'to give'

Preterite 3sg.
*bar '(s)he carried'
*gab '(s)he gave'

Preterite 3pl.
*be:run 'they carried'
*ge:bun 'they gave'

Here the present stems and 3sg. preterites are exactly parallel to those adduced above, but the 3pl. preterites clearly are not; we expect to find *brun and *gbun, and we cannot suggest that a *long* vowel has been inserted into the stems of these forms by any plausible phonetic process of epenthesis! The parallelism simply breaks down – and from the point of view of IR, that necessarily casts doubt on our conclusions regarding *bundun and *wurpun. Once again it appears that external evidence (in this case CR with Sanskrit) has been the really decisive factor in validating our inferences.

NOTES

- 1 Readers will find that many of the examples used here also appear in Fox (1995) and in much older work. This is partly because they have become traditional in the field, but also (and especially) because the number of relevant examples whose development is certainly known in great detail is limited, and we must choose our illustrations from that limited range.
- 2 This and other examples will be simplified slightly in order to make the presentation of principles clearer; for instance, in at least some pronunciations of Standard German the rule in question devoices *syllable*-final obstruents. Similar phenomena can be observed in Netherlandic, Polish, Russian, and numerous other languages, any of which could just as well have been used to exemplify the point at issue.
- 3 These data are given in “classical” phonemes, a system based solely on surface contrasts; see the discussion immediately below. Throughout this chapter phonemic representations will be enclosed in slashes. This is not an exhaustive list of German nouns in /-a:t/.
- 4 For example, one might conceivably propose that the words with alternating stem-final consonants were inherited, while those with invariant stem-final consonants were recent borrowings.
- 5 Of course the vowels and other details might have been different; strictly speaking, we are here reconstructing only the stem-final consonants. Throughout this chapter reconstructed forms will be marked with asterisks.
- 6 We find *pfat*, *pfade*, etc. already in twelfth-century Middle High German; *Grad* was borrowed several centuries later, toward the end of the Middle Ages (Kluge 1957: s.v.).
- 7 In traditional historical linguistics “morphological structure” is broadly defined; reanalysis of the underlying shape of a lexeme on the basis of surface forms is included simply because some substantial degree of abstraction is involved. Modern theory views some such phenomena as strictly phonological.
- 8 This is a somewhat simplified account of what really happened, not because of any inadequacy in the principles of IR, but because I have restricted the range of data in order to keep this illustration manageable. Consideration of examples involving the contraction products of *ea, for instance, would

- lead to a more complex account by the same principles of IR.
- 9 This and similar lines of reasoning depend on the observation that the operation of sound changes is restricted both in time and in (social) space: each sound change occurs in a particular speech-community, speaking a particular dialect of a particular language, over a particular span of time; it need not be repeated in any other speech-community, or at any subsequent time. (Of course sound changes can spread from one community to another, and “natural” sound changes can occur repeatedly in communities and generations that have no connection with one another; but each such event must be demonstrated separately.)
 - 10 In the form given, the acute accent has been changed to a circumflex by a regular rule which need not concern us here.
 - 11 The pattern of endings – especially plural endings – makes the class membership of noun stems unambiguous in Ancient Greek, as even a cursory perusal of Smyth (1956: 48–71) will show.
 - 12 I report spellings of words found only in inscriptions between angled brackets.
 - 13 The form actually attested is a masc.nom.pl. participle; the manuscripts all read /kerdá:nantes/, though editors typically replace the first alpha with an eta.
 - 14 For example, in /mê:tɛ:r/ ‘mother’ we can tell that the second /ɛ:/ is original because it alternates with /e/ (cf. nom. pl. /mɛ:téres/ ‘mothers’); but the first /ɛ:/, which does not alternate, is shown to be *a: only by the comparative evidence of Doric /má:tɛ:r/ (or, still further afield, Latin /ma:ter/).
 - 15 Putative exceptions are questionable; see Sihler (1995: 171–3), especially §173 n. (a).
 - 16 The Latin “supine” is an infinitive of very restricted distribution; for example, the accusative form, given here, is used only to indicate purpose after a verb of motion. A typical example is *sessum it praetor* ‘the appellate judge goes to take his seat’ (Cicero, *On the nature of the gods* 3.74).
 - 17 The phonological development of the stem-final clusters can be easily – almost trivially – reconstructed as *ts, *ds > *ss > /s/. The original shape of the supine suffix is much less obvious on internal grounds, but it is still clear that it begins with a consonant.
The invariant perfect infinitive ending /-isse/ is not at issue here. Note that the perfect stem of ‘sit’ is constructed in a completely different manner, which need not concern us here.
 - 18 The second /o/ in nom.sg. /honor/ has been shortened automatically by a phonological rule shortening any long vowel in a polysyllabic word before word-final /r/. For an example in a completely different class of nouns (recoverable only by CR) see n. 14.
 - 19 I hasten to add that *comparative* evidence does show that /genus/, /gener-/ exhibits /-s/ ~ /-r-/ < *s; the argument here merely questions the extent to which that is recoverable by IR alone.
 - 20 Still less obvious is the fact that the elements /-is-/ and /-er-/ found in many endings of the perfect active system both reflect earlier *-is-, with *s > /r/ between vowels and subsequently *i > /e/ before /r/. One reason for the opacity of this example seems to be the fact that the element showing the alternation

is completely functionless, and is thus much less likely to be identified as a grammatical element at all.

- 21 Namely /s, z, š, ž, č, ĵ/, as in *horses, noses, ashes, garages, churches, judges* respectively.
- 22 One might suggest instead that the original paradigm was *liyv, *liyvz, and that the word-final *-v was devoiced to /-f/ in the singular (since word-final devoicing of fricatives is a reasonably common sound change cross-linguistically); but in that case it would not be easy to explain why the *-z of the plural was not also devoiced. Of course we might suggest that it *was* devoiced, but that the resulting cluster *-vs then underwent progressive voicing assimilation to /-vz/; but this hypothesis is so much more complex than the one offered in the text that it would not be reasonable to prefer it in the absence of substantial further evidence in its favor.
- To account for the lone noun paradigm showing stem-final /-s/ ~ /-z/, namely /haws/ 'house,' pl. /hawzəz/, at least one further hypothesis is needed; but that detail need not concern us here.
- 23 In addition, we need to posit a later progressive voicing assimilation rule to account for the /-s/ of these plurals; but we would need that anyway to account for the plurals of nouns ending in voiceless stops (such as /kæps/ 'caps' and /kæts/ 'cats'), which always exhibit invariant stems (cf. Jespersen 1909: 202).
- 24 Most of the examples given here have actually undergone many

more sound changes than 'wolf'; for example, /nayf/ was /kni:f/ in OE, and /lowf/ was OE /hla:f/ 'bread.' *Scarf* is an Old French word which has been attracted into this class by analogy – a development which, as usual, is completely inaccessible to IR.

Careful readers will note that the OE plural ending in question is written with the symbol for a voiceless, not a voiced, fricative. In fact voicing of fricatives was not contrastive in OE, but it seems clear that word-final fricatives were phonetically voiceless, so that the ending /-as/ was actually pronounced [-as]. The final consonant of the modern ending /-əz/ reflects voicing of fricatives in unstressed syllables in early Modern English; see Jespersen (1909: 199–206). I doubt that most of these developments are accessible to IR from present-day English, no matter how extensive the data adduced.

- 25 This PA segment is now commonly reconstructed as /l/; that makes some of the sound changes it underwent appear more plausible phonetically, but it may actually make the alternation under discussion appear less plausible – a consideration that seems to be absent from the rather dogmatic treatment of this question in Picard (1994: 10–12).
- 26 On the meaning of the ending of this form see Goddard (1967: 69–75), especially p. 72.
- 27 The post-PA analogical change of *l to *š likewise took place only before high front vocalics, not before *e.

4 How to Show Languages are Related: Methods for Distant Genetic Relationship

LYLE CAMPBELL

Judging from media attention, the “hottest” current topic in linguistics (shared perhaps with endangered languages) is distant genetic relationship. Proposed remote language families such as Amerind, Nostratic, and Proto-World have been featured in *Atlantic Monthly*, *Nature*, *Science*, *Scientific American*, *U.S. News*, and television documentaries, and yet these same proposals have been roundly rejected by the majority of practicing historical linguistics. This has led to charges that these spurnings “are clumsy and dishonest attempts to discredit deep reconstructions,” “stem from ignorance,” and “very few [antagonist linguists] have ever bothered to examine the evidence first-hand . . . To really screw up classification you almost have to have a Ph.D. in historical linguistics” (Shevoroshkin 1989a: 7, 1989b: 4; Ruhlen 1994: viii). In spite of such sharp differences of opinion, all agree that a successful demonstration of linguistic kinship depends on adequate methods – the disagreement is on what these are – and hence methodology assumes the central role in considerations of possible remote relationships. This being the case, the purpose of this chapter is to survey the various methodological principles, criteria, and rules of thumb relevant to distant genetic relationship and thus hopefully to provide guidelines for both initiating and testing proposals of distant linguistic kinship.

In practice the successful methods for establishing distant genetic relationship (henceforth DGR) have not been different from those used to validate any family relationship, near or not. The comparative method has always been the basic tool for establishing genetic relationships. The fact that the methods have not been different may be a principal factor making DGR research so perplexing. The result is a continuum from established and non-controversial families (e.g., Indo-European, Uto-Aztecan, Bantu), through more distant but solidly supported relationships (e.g., Uralic, Siouan-Catawban), to plausible but inconclusive proposals (e.g., Indo-Uralic, Afro-Asiatic, Aztec-Tanoan), to questionable but not implausible ones (e.g., Altaic, Austro-Tai, Maya-Chipayan), to virtually impossible proposals (e.g., Basque-NaDene, Quechua-Turkic, Miwok-Uralic). It is difficult to segment this continuum so that plausible proposals based on legitimate procedures and reasonable supporting evidence fall sharply on one

side of a line and are distinguished from clearly unlikely hypotheses clustering on the other side.

We can distinguish two outlooks, or stages in research on potential DGRs, each with its own practices. The quality of the evidence presented typically varies with the proposer's intent. Where the intention is to call attention to a possible but as yet untested connection, one often casts a wide net in order to haul in as much potential evidence as possible. When the intention is to test a proposal that is already on the table, those forms admitted initially as possible evidence are submitted to more careful scrutiny. Unfortunately, the more *laissez-faire* setting-up type hypotheses are not always distinguished from the more cautious hypothesis-testing type. Both orientations are valid. Nevertheless, long-range proposals which have not been evaluated carefully cannot move to the more established end of the continuum. Methodology is worthy of concern if we cannot easily distinguish fringe proposals from more plausible ones. For this reason, careful evaluation of the evidence is called for. Some methods are more successful than others, but even successful ones can be applied inappropriately. As is well known, excessive zeal for long-range relationships can lead to methodological excesses: "The difficulty of the task of trying to make every language fit into a genetic classification has led certain eminent linguists to deprive the principle of such classification of its precision and its rigor or to apply it in an imprecise manner" (Meillet 1948[1914]: 78).¹ Therefore, I turn to an appraisal of methodological considerations involved in procedures for investigating potential DGRs.

1 Lexical Comparison

Throughout history, word comparisons have been employed as evidence of family relationship, but "given a small collection of likely-looking cognates, how can one definitely determine whether they are really the residue of common origin and not the workings of pure chance or some other factor? This is a crucial problem of long-range comparative linguistics" (Swadesh 1954: 312). The results of lexical comparisons were seldom convincing without additional support from other criteria, for example, sound correspondences and compelling morphological agreements (see below). Use of lexical material alone (or as the primary source of evidence) often led to incorrect proposals and hence has proven controversial. The role of basic vocabulary and lexically based approaches requires discussion.

1.1 Basic vocabulary

Most scholars have insisted on basic vocabulary (*Kernwortschatz*, *vocabulaire de base*, *charakteristische Wörter*, "non-cultural" vocabulary, understood intuitively to contain terms for body parts, close kin, frequently encountered aspects of

the natural world, and low numbers) as an important source of supporting evidence. It is assumed that since, in general, basic vocabulary is resistant to borrowing, similarities found in comparisons involving basic vocabulary are unlikely to be due to diffusion and hence stand a better chance of being due to inheritance from a common ancestor. Of course, basic vocabulary can also be borrowed (see examples below), though infrequently, so that its role as a safeguard against borrowing is not foolproof.

1.2 *Glottochronology*

Glottochronology, which depends on basic, relatively culture-free vocabulary, has been rejected by most linguists, since all its basic assumptions have been challenged (cf. Campbell 1977: 63–5). Therefore, it warrants little discussion here; suffice it to say that it does not find or test relationships, but rather it *assumes* that the languages compared are related and proceeds to attach a date based on the number of core-vocabulary words that are similar between the languages compared. This, then, is no method for determining whether languages are related or not.

A question about lexical evidence in long-range relationships has to do with the loss or replacement of vocabulary over time. It is commonly believed that “comparable lexemes must inevitably diminish to near the vanishing point the deeper one goes in comparing remotely related languages” (Bengtson 1989: 30), and this does not depend on glottochronology’s assumption of a constant rate of basic vocabulary loss through time and across languages. In principle, related languages long separated may undergo so much vocabulary replacement that insufficient shared original vocabulary will remain for an ancient shared kinship to be detected. This constitutes a serious problem for those who believe in deep relationships supported solely by lexical evidence.

1.3 *Multilateral (or mass) comparison*

The best known of current approaches which rely on inspectional resemblances among compared lexical items is Greenberg’s multilateral (or mass) comparison. It is based on lexical look-alikes determined by visual inspection, “looking at . . . many languages across a few words” rather than “at a few languages across many words” (Greenberg 1987: 23), where the lexical similarity shared “across many languages” alone is taken as evidence of genetic relationship. As has been repeatedly pointed out, this is but a starting-point. The inspectional resemblances must still be investigated to determine whether they are due to inheritance from a common ancestor or to borrowing, accident, onomatopoeia, sound symbolism, nursery formations, and the like, discussed here. Since multilateral comparison does not take this necessary next step, the results frequently have proven erroneous or at best highly controversial.

Actually, Greenberg's conception of multilateral (or mass) comparison has undergone telling mutations. Greenberg (1957) was rather mainstream, advocating standard criteria, for example, "semantic plausibility, breadth of distribution in the various subgroups of the family, length [of compared forms], participation in irregular alternations, and the occurrence of sound correspondences" (Greenberg 1957: 45). Still, his emphasis was on vocabulary (Greenberg 1957: 42). His 1957 notion of mass comparison was seen as only supplementary to the standard comparative method; in 1987 he sees it as superior to and replacing the standard procedures (Greenberg 1987). The 1957 version concentrated on a language (or group of related languages taken as a unity) whose relationship was yet to be determined, comparing this with languages whose family relationships were already known:

Instead of comparing a few or even just two languages chosen at random and for linguistically extraneous reasons, we proceed systematically by first comparing closely related languages to form groups with recurrent significant resemblances and then compare these groups with other similarly constituted groups. Thus it is far easier to see that the Germanic languages are related to the Indo-Aryan languages than that English is related to Hindustani. In effect, we have gained historic depth by comparing each group as a group, considering only those forms as possessing likelihood of being original which are distributed in more than one branch of the group and considering only those etymologies as favoring the hypothesis of relationship in which tentative reconstruction brings the forms closer together. Having noted the relationship of the Germanic and Indo-Aryan languages, we bring in other groups of languages, e.g. Slavonic and Italic. In this process we determine with ever increasing definiteness the basic lexical and grammatical morphemes in regard to both phonetic form and meaning. On the other hand, we also see more easily that the Semitic languages and Basque do not belong to this aggregation of languages. *Confronted by some isolated language without near congeners, we compare it with this general Indo-European rather than at random with single languages.* (Greenberg 1957: 40–1; my emphasis)

Greenberg's multilateral comparison of 1987 is not of the gradual build-up sort that it was in Greenberg 1957, where the method was based on the comparison of an as yet unclassified language with a number of languages previously demonstrated to be related. An array of cognate forms in languages known to be related might reveal similarities with a form compared from some language whose genetic affiliation we are attempting to determine, where comparison with but a single language from the related group may not. Given the possibilities of lexical replacement, the language may or may not have retained the cognate form which may still be seen in some of its sisters which did not replace it. However, this is equivalent, in essence, to the recommendation that we reconstruct lower-level, accessible families – where proto-forms can be reconstructed on the basis of the cognate sets, although for some sets some individual languages have lost or replaced the cognate word – before we proceed to higher-level, more inclusive families. A validly reconstructed

proto-form is like the “multilateral comparison” of the various cognates from across the family upon which the reconstruction of that form is based. For attempts to establish more remote genetic affiliations, comparison with either the reconstructed proto-form or the language-wide cognate set upon which the reconstruction would be based are roughly equivalent. Greenberg (1987) abandons this, now comparing “a few words” in “many languages” of uncertain genetic affiliation.

In short, no technique which relies solely on inspectional similarities has proven adequate for supporting relationships:

It is widely believed that, when accompanied by lists of the corresponding sounds, a moderate number of lexical similarities is sufficient to demonstrate a linguistic relationship . . . However, . . . the criteria which have usually been considered necessary for a good etymology are very strict, even though there may seem to be a high a priori probability of relationship when similar words in languages known to be related are compared. In the case of lexical comparisons it is necessary to account for the whole word in the descendant languages, not just an arbitrarily segmented “root,” and the reconstructed ancestral form must be a complete word . . . The greater the number of descendant languages attesting a form, and the greater the number of comparable phonemes in it, the more likely it is that the etymology is a sound one and the resemblances not merely the result of chance. A lexical similarity between only two languages is generally considered insufficiently supported, unless the match is very exact both phonologically and semantically, and it is rare that a match of only one or two phonemes is persuasive. If the meanings of the forms compared differ, then there must be an explicit hypothesis about how the meaning has changed in the various cases. Now, if these strict criteria have been found necessary for etymologies within *known* linguistic families, it is obvious that much stricter criteria must be applied to word-comparisons between languages whose relationship is in question. (Goddard 1975: 254–5)

2 Sound Correspondences

It is important to emphasize the value and utility of sound correspondences in the investigation of linguistic relationships. Some hold recurring regular sound correspondences necessary for the demonstration of linguistic affinity, and most at least consider them strong evidence of genetic affinity. While they are a staple of traditional approaches to determining language families, it is important to discuss how their use can be perverted.

First, it is important to keep in mind that it is correspondences which are crucial, not mere similarities, and that such correspondences do not necessarily involve very similar sounds. It is surprising how the matched sounds in proposals of remote relationship are typically so similar, often identical, while among the daughter languages of well-established, non-controversial, older language families such identities are not as frequent. While some sounds may

stay relatively unchanged, many undergo changes which leave phonetically non-identical correspondences. One wonders why correspondences that are not so similar are not more common in such proposals. The sound changes that lead to such non-identical correspondences often change cognate words so much that their cognacy is not apparent. These true but non-obvious cognates are missed by methods such as multilateral comparison which seek inspectional resemblances. For example, Hindi *cakkā* (cf. Sanskrit *cakra-*) and *sīg* (cf. Sanskrit *śrīṅga-*) are true cognates of English *wheel* and *horn*, respectively (cf. Proto-Indo-European (PIE) **k^wek^wlo-* ‘wheel’ and **ker/kr-* ‘horn’: Hock 1993a), but such forms would be missed by lexical-inspection approaches. A method which scans only for phonetic resemblances (as multilateral comparison does) misses such well-known true cognates as French *cinq*/Russian *p^ʷat^ʷ*/Armenian *hing*/English *five* (all easily derived by straightforward changes from original Indo-European (IE) **penk^we* ‘five’), French *boeuf*/English *cow* (from PIE **g^wou-*), French /nu/ (spelled *nous*) ‘we, us’/English *us* (from PIE **nes-*; French through Latin *nōs*, English from Germanic **uns* [IE zero-grade **n_s]*) (Meillet 1948 [1914]: 92–3); none of these common cognates is visually similar.

There are a number of ways in which sound correspondences can be misapplied. They usually indicate a historical connection, though sometimes it is not easy to determine whether this is due to inheritance from a common ancestor or to borrowing. Regularly corresponding sounds may also be found in loans. For example, it is known from Grimm’s law that real French–English cognates should exhibit the correspondence *p* : *f*, as in *père*/*father*, *piéd*/*foot*, *pour*/*for*. However, French and English appear to exhibit also the correspondence *p* : *p* in cases where English has borrowed from French or Latin, as in *paternel*/*paternal*, *piédestal*/*pedestal*, *per*/*per*. Since English has many such loans, examples illustrating this bogus *p* : *p* sound correspondence abound. “The presence of recurrent sound correspondences is not in itself sufficient to exclude borrowing as an explanation. Where loans are numerous, they often show such correspondences” (Greenberg 1957: 40). In comparing languages not yet known to be related, we must use caution in interpreting sound correspondences to avoid the problems of undetected loans. Generally, sound correspondences found in basic vocabulary warrant the confidence that the correspondences are not found only in loans, though even here one must be careful, since basic vocabulary also can be borrowed, though more rarely. For example, Finnish *äiti* “mother” and *tytär* “daughter” are borrowed from Indo-European languages; if these loans were not recognized, one would suspect a sound correspondence of *t* : *d* involving the medial consonant of *äiti* (cf. Germanic **aidī*) and the initial consonant of *tytär* (cf. Germanic **dohtēr*) on the basis of these fundamental vocabulary items (supported also by many other loans).²

In addition to borrowings, there are other ways by which proposals which purport to rely on sound correspondences come up with phony correspondences. Some apparent but non-genuine correspondences come from accidentally similar lexical items among languages, for example, Proto-Je **niw* ‘new’/English *new*; Qaqchikel dialects *mes* ‘mess, disorder, garbage’/English *mess*;

Jaqaru *aska* 'ask' /English *ask*; Lake Miwok *hóllu* 'hollow' /English *hollow*; Seri *ki?* /French *qui* (/ki/) 'who?'; Yana *t'inii-* 'small' /English *tiny, teeny*, not to mention those of handbook fame Persian *bad* /English *bad*, and Malay *mata* 'eye' /Modern Greek *mati* 'eye,' to mention but a few examples. Other cases of unreal sound correspondences turn up if one permits promiscuous semantic latitude in proposed cognates, such that phonetically similar but semantically disparate forms are equated (Ringe 1992). Gilií (1780–4, quoted from 1965: 132–3) showed this long ago with several examples of the sort *poeta* 'drunk' in Maipure, 'poet' in Italian; *putta* Otomaco 'head,' Italian prostitute.' The phonetic correspondences in such cases are due to accident, since it is always possible to find phonetically similar words among languages if their meaning is ignored. When one sanctions semantic liberty among compared forms, one easily comes up with the sort of spurious correspondences seen in the initial *p* : *p* and medial *t* : *t* of Gilií's Amazonian–Italian 'drunk–poet' and 'head–prostitute' forms. Additional non-inherited phonetic similarities crop up when onomatopoeic, sound-symbolic, and nursery forms are compared. A set of proposed cognates involving a combination of loans, chance enhanced by semantic latitude, onomatopoeia, and such factors may exhibit seemingly real but false sound correspondences. For this reason, some proposed remote relationships whose propounders profess allegiance to regular sound correspondences nevertheless fail to be convincing. (See Ringe 1992, and below.)

Most find sound correspondences strong evidence, but many neither insist on them solely nor trust them fully, though most do insist on the comparative method (see Watkins 1990). While the comparative method is often associated with sound change, and hence with regularly recurring sound correspondences, this is not essential. For example, Meillet (1925, quoted from 1967: 13–4) introduced the comparative method, not with examples of phonological correspondences, but with reference to comparative mythology. Thus, many have relied also on grammatical comparisons of the appropriate sort.

3 Grammatical Evidence

Scholars throughout linguistic history have held morphological evidence important for establishing language families. Meillet, like many others, favored "shared aberrancy" as morphological proof (Meillet 1925, quoted from 1967: 36), illustrated, for example, by suppletion in the verb 'to be' in branches of Indo-European:

	3sg.	3pl.	1sg.
Latin	est	sunt	sum
Sanskrit	ásti	sánti	asmi
Greek	esti	eisi	eimi
Gothic	ist	sind	am

Meillet favored “particular processes,” “singular facts,” “local morphological peculiarities,” “anomalous forms,” and “arbitrary” associations (i.e., “shared aberrancy”):

The more singular the facts are by which the agreement between two languages is established, the greater is the conclusive force of the agreement. *Anomalous forms* are thus those which are most suited to establish a “common language.” (Meillet 1925, quoted from 1967: 41; my emphasis)

What conclusively establish the continuity between one “common language” and a later language are the particular processes of expression of morphology. (Meillet 1925, quoted from 1967: 39; my emphasis)

Meillet’s use of grammatical evidence is considered standard practice.³ Sapir’s “submerged features” are interpreted as being similar:

When one passes from a language to another that is only remotely related to it, say from English to Irish or from Haida to Hupa or from Yana to Salinan, one is overwhelmed at first by the great and obvious differences of grammatical structure. As one probes more deeply, however, significant resemblances are discovered which weigh far more in a genetic sense than the discrepancies that lie on the surface and that so often prove to be merely secondary dialectic developments which yield no very remote historical perspective. In the upshot it may appear, and frequently does appear, that the most important grammatical features of a given language and perhaps the bulk of what is conventionally called its grammar are of little value for the remoter comparison, which may rest largely on *submerged features* that are of only minor interest to a descriptive analysis. (Sapir 1925: 491–2; my emphasis)

Sapir apparently viewed these as “morphological resemblances of detail which are so peculiar as to defy all interpretation on any assumption but that of genetic relationship” (letter from Sapir to Kroeber, 1912, in Golla 1984: 71). Following Meillet’s and Sapir’s technique, “we often find our most valuable comparative evidence in certain irregularities in fundamental and frequent forms, like prize archaeological specimens poking out of the mud of contemporary regularity” (Krauss 1969: 54). Teeter’s (1964: 1029) comparison of Proto-Central-Algonquian (PCA) and Wiyot exemplifies the method well, where in PCA a *-t-* is inserted between a possessive pronominal prefix and a vowel-initial root, while in Wiyot a *-t-* is inserted between possessive prefixes and a root beginning in *hV* (with the loss of the *h-*):

PCA	<i>*ne + *ehkw-</i>	= <i>*netchkw-</i>	‘my louse’
Wiyot	<i>du- + híkw</i>	= <i>duíkw</i>	‘my louse’

The Algonquian-Ritwan hypothesis, which groups Wiyot and Yurok with Algonquian (Sapir 1913), was controversial, but evidence such as Teeter’s

proved the relationship to everyone's satisfaction (cf. Haas 1958; Goddard 1975).

Swadesh (1951: 7) attempted to test the ability of Sapir's notion to distinguish between borrowed and inherited features by applying it to French and English. He was impressed by some "formational irregularities that could hardly come over with borrowed words" (p. 8), suggesting that "if the last vestigial similarity involved a deep-seated coincidence in formation, such as that between English *I-me* and French *je-moi* then even one common feature would be strongly suggestive of common origin rather than borrowing . . . However, it could also constitute a chance coincidence with no necessary historical relationship at all" (p. 8). Greenberg also advocated the Meillet/Sapir approach, speaking of "agreement in irregularities" and "highly arbitrary alternations": "an agreement like that between English 'good'/'better'/'best' and German *gut/besser/best* is obviously of enormous probative value" (Greenberg 1957: 37–8, 1987: 30).

Morphological correspondences of the "shared aberrancy"/"submerged-features" type, just as sound correspondences, are accepted generally as an important source of evidence for distant genetic relationships. Nevertheless, highly recommended though such grammatical evidence is, caution in its interpretation is necessary. There are impressive cases of apparent idiosyncratic grammatical correspondences which in fact have non-genetic explanations (accident or borrowing). For example, Quechua and K'iche' (Mayan) share seemingly submerged features. Both have two distinct sets of first person affixes which are strikingly similar: Quechua II *-ni-* and *-wa-*, K'iche' *in-* and *w-*. However, this idiosyncratic similarity is a spurious correlation. Quechua II *-ni-* is derived historically from the empty morph *-ni-* which is inserted between morphemes when two consonants would come together. The original first person morpheme was **-y*, which followed empty morph *-ni-* when attached to consonant-final roots (*-C+ni+y*), but the final *-y* fused with the *i* and the first person was reanalyzed as *-ni* (e.g., *-ni+y > -ni*) (Cerrón-Palomino 1987: 124–6, 139–42). The Quechua II *-wa-* comes from Proto-Quechua **ma*, as in Quechua I cognates (Cerrón-Palomino 1987: 149). What seemed like an idiosyncratic similarity (Quechua II *ni/wa*, K'iche' *in/w* "first person" – like Swadesh's *I-me/je-moi* example) is actually Quechua **y/*ma*, K'iche' *ni/w* (Proto-Mayan **in-* and **w-*), an accidental similarity that turns out not to be similar at all. Quechua and K'iche' exhibit another example, the phonetically similar discontinuous negation construction: Quechua II *mana . . . ču*, K'iche' *man . . . tah*. This example, too, dissolves under scrutiny. Proto-Mayan negation had only **ma*; the K'iche' discontinuous construction came about when **tah* 'optative' became obligatory with negatives. The accurate comparison is Quechua *mana . . . ču* : K'iche' *ma*, not so striking.⁴ If Quechua and K'iche' can share two seemingly submerged features by accident, the lesson is clear: caution is necessary in the interpretation of morphological evidence. (For additional examples of this sort and discussion of other problems involving grammatical comparisons, see Campbell 1995.)

4 Borrowing

Since it is generally recognized that diffusion, a source of non-genetic similarity among languages, can complicate evidence for remote relationships, it should suffice just to mention that efforts must be taken to eliminate borrowings. However, too often scholars well aware of this problem still err in not eliminating loans. The problem is illustrated by Greenberg's (1987: 108) 'axe' "etymology," which he assumed to be evidence for his "Chibchan-Paezan" hypothesis; forms from only four languages were cited, two of which involve loans – that is, half the evidence for this set: Cuitlatec *navaxo* 'knife,' borrowed from Spanish *navajo* 'knife, razor'; Tunebo *baxi-ta* 'machete,' from Spanish *machete*.⁵ In the case of the Nostratic hypothesis (see Illich-Svitych 1989a, 1989b, 1990; Kaiser and Shevoroshkin 1988), given Central Eurasia's history of wave after wave of conquest, expansion, migration, trade, and exchange, of multilingual and multi-ethnic states, it is not surprising that some of the forms cited as evidence are confirmed, others probable loans, for example, 'vessel,' 'practice witchcraft,' 'honey,' 'birch,' 'bird-cherry,' 'poplar,' 'conifer,' etc. (see Campbell 1998 for details). Since it is not always possible to recognize loans in advance, it is frequently suggested, as mentioned above, that "the borrowing factor can be held down to a very small percentage by sticking to non-cultural words" (Swadesh 1954: 313). That is, in case of doubt, more credit is due basic vocabulary because it is less likely to be borrowed. By this heuristic, these Nostratic forms must be set aside. While this is good practice, it must be remembered (as mentioned above) that even basic vocabulary can sometimes be borrowed. Finnish borrowed from its Baltic and Germanic neighbors various terms for basic kinship and body parts, such as 'mother,' 'daughter,' 'sister,' 'tooth,' 'navel,' 'neck,' 'thigh,' 'fur,' etc. Based on the approximately 15 percent of the 3000 most common words in Turkish and Persian being Arabic in origin, it has been claimed that, "if Arabic, Persian, and Turkish were separated now and studied 3,000 years hence by linguists having no historical records, lists of cognates could easily be found, sound correspondences established, and an erroneous genetic relationship postulated" (Pierce 1965: 31). Closer to home, English has borrowed basic vocabulary items from French or Latin for 'stomach,' 'face,' 'vein,' 'artery,' 'intestine,' 'mountain,' 'navel,' 'pain,' 'penis,' 'person,' 'river,' 'round,' 'saliva,' 'testicle,' and 'vein.' The problem of loans and potential loans is very serious.

5 Semantic Constraints

It is dangerous to assume that phonetically similar forms with different meanings can legitimately be compared in proposals of remote genetic relationship because they may have undergone semantic shifts. Meaning can shift (e.g.,

Albanian *motër* 'sister,' from Indo-European 'mother'), but in hypotheses of remote relationship the assumed shifts cannot be documented, and the greater the semantic latitude permitted in compared forms, the easier it is to find phonetic similarity (as in Giliĭ's examples, above). When semantically non-equivalent forms are compared, the possibility that chance accounts for the phonetic similarity is greatly increased. As Ringe has shown, "admitting comparisons between non-synonyms cannot make it easier to demonstrate the relationship of two languages . . . it can only make it more difficult to do so" (Ringe 1992: 67). Only after a hypothesis has been seen to have some merit based on semantically equivalent forms could one entertain the idea of semantic shifts, and even then it should be borne in mind that etymology within families where the languages are known to be related still requires an explicit account of any assumed semantic changes. Swadesh's (1954: 314) advice is sound: "count only exact equivalences." The problem of semantic promiscuity is one of the most common and most serious in long-range proposals; I mention but a few random examples for illustration's sake (citing only the glosses of the various forms compared). In Illich-Svitych's (1990) Nostratic: 'lip/mushroom/soft outgrowth', 'grow up/become/tree/be', 'crust/rough/scab' (also Kaiser and Shevoroshkin 1988). In Ruhlen's (1994: 322–3) global etymology for 'finger, one': 'one/five/ten/once/only/first/single/fingernail/finger/toe/hand/palm of hand/arm/foot/paw/guy/thing/to show/to point/in hand/middle finger'. In Greenberg's (1987) Amerind: 'excrement/night/grass', 'body/belly/heart/skin/meat/be greasy/fat/deer', 'child/copulate/son/girl/boy/tender/bear/small', and 'field/devil/bad/underneath/bottom'.

6 Onomatopoeia

Onomatopoeic forms may be similar because the different languages have independently approximated the sounds of nature, and they must be eliminated from proposals of DGR. "A simple way to reduce the sound-imitative factor to a negligible minimum is to omit from consideration all such words as 'blow, breathe, suck, laugh' and the like, that is all words which are known to lean toward sound imitation" (Swadesh 1954: 313). Judgments of what is onomatopoeic are subjective, and possible onomatopes to be eliminated are forms whose meaning plausibly lends itself to mimicking the sounds of nature which frequently are seen to have similar phonetic shapes in unrelated languages. For example, one finds in most proposals of DGR forms for 'blow/wind' being compared which approximate $p(h)u(h/x/w/f)$, and for 'breast/suckle, nurse/suck' (V)mVm/n, s/š/ts/čVp/b/k, or s/š/ts/čVs/š/ts/č, as seen in Nostratic *p^[h]uw-/*p^[h]low- 'to blow,' *mun-at^y 'breast, to suckle,' *mal- 'to suck' (Bomhard and Kerns 1994); among forms for the Austro-Thai hypothesis *piyup, *piu^c, *pyom 'to blow/breath/wind,' *tšítší, *[tš]i, sê 'breast,' *(n)tšuptšup, *suup, sui, sop-i 'suck' (Benedict 1990); and in Amerind *pusuk*, *puti*, *pōta* 'to blow,' *puluk*

'wind,' *mana*, *neme*, *nano*, *ču*, *žiču*, *si* 'breast' (Ruhlen 1994). A few others which frequently are similar across languages due to onomatopoeia are: 'cough,' 'sneeze,' 'break/cut/chop/split,' 'cricket,' 'crow' (and many bird names in general), 'frog/toad,' 'lungs,' 'baby/infant,' 'beat/hit/pound,' 'call/shout,' 'breathe,' 'choke,' 'cry,' 'drip/drop,' 'hiccough,' 'kiss,' 'shoot,' 'snore,' 'spit,' 'whistle.'

7 Sound Symbolism

"Sound symbolism" involves variation in a language's sounds which depends principally on "size" and/or "shape." Size-shape sound symbolism is related to expressive/iconic symbolism in general, probably a subtype thereof, though sound symbolism can more easily become part of a language's grammatical structure. For example, a long-short vowel opposition is not a marker of bigger versus smaller things in English grammar, but it is in some languages. Productive sound symbolism is attested in many languages (cf. Delisle 1981; Nichols 1971). Regular sound correspondences can have exceptions in cases where sound symbolism is involved, and this can complicate historical linguistic investigations, including proposals of DGR (for several examples, see Campbell 1997a: 226–7). Caution must be exercised to detect similarities among compared languages not yet known to be related which may stem from sound symbolism rather than from common ancestry.

8 Nursery Forms

It has been recognized for centuries that nursery formations (so-called *Lallwörter*, the mama–nana–papa–dada–caca sort of words) should be avoided in considerations of potential linguistic affinities, since these typically share a high degree of cross-linguistic similarity which is not due to common ancestry. Nevertheless, examples of these are frequent in evidence put forward for DGR proposals. The forms involved are typically 'mother,' 'father,' 'grandmother,' 'grandfather,' and often 'brother,' 'sister' (especially elder siblings), 'aunt,' and 'uncle,' and have shapes like *mama*, *nana*, *papa*, *baba*, *tata*, *dada*; nasals are found more in terms for females, stops for males, but not exclusively so. Murdock (1959) investigated 531 terms for 'mother' and 541 for 'father' to test for "the tendency of unrelated languages to develop similar words for father and mother on the basis of nursery forms" (Jakobson 1960, quoted from 1962: 538), concluding that the data "confirm the hypothesis under test – a striking convergence in the structure of these parental kin terms throughout historically unrelated languages" (p. 538). Jakobson explained the non-genetic

similarity among such terms cross-linguistically as nursery forms which enter common adult vocabulary:

Often the sucking activities of a child are accompanied by a slight nasal murmur, the only phonation which can be produced when the lips are pressed to mother's breast or to feeding bottle and the mouth is full. Later, this phonatory reaction to nursing is reproduced as an anticipatory signal at the mere sight of food and finally as a manifestation of a desire to eat, or more generally, as an expression of discontent and impatient longing for missing food or absent nurser, and any ungranted wish . . . Since the mother is, in Grégoire's parlance, *la grande dispensatrice*, most of the infant's longings are addressed to her, and children . . . gradually turn the nasal interjection into a parental term, and adapt its expressive make-up to their regular phonemic pattern. (pp. 542–3)

He reported a "transitional period when *papa* points to the parent present [mother or father], while *mama* signals a request for fulfillment of some need or for the absent fulfiller of childish needs, first and foremost but not necessarily the mother," and eventually the nasal-mother, oral-father association becomes established and then expands to terms not confined to just parents (p. 543). This helps explain frequent spontaneous, symbolic, affective developments, seen when inherited *mother* in English is juxtaposed to *ma*, *mama*, *mamma*, *mammy*, *mommy*, *mom*, *mummy*, *mum*, and *father* is compared with *pa*, *papa*, *pappy*, *pop*, *poppy*, *da*, *dad*, *dada*, *daddy*). In sum, nursery words do not provide reliable support for distant genetic proposals.

9 Short Forms and Unmatched Segments

The length of proposed cognates and the number of matched segments within them are important, since the greater the number of matched segments in a proposed cognate set, the less likely it is that accident may account for the similarity (cf. Meillet 1948: 89–90). Monosyllabic CV or VC forms may be true cognates, but they are so short that their similarity to forms in other languages could also easily be due to chance. Likewise, if only one or two segments of longer forms are matched, then chance remains a strong candidate for the explanation of the similarity. Such forms will not be persuasive; the whole word must be accounted for. (See Ringe 1992 for mathematical proof.)

10 Chance Similarities

Chance (accident), mentioned several times above, is another possible explanation of similarities in compared languages, and its avoidance in questions of deep family relationships is crucial:

Resemblances between languages do not demonstrate a linguistic relationship of any kind unless it can be shown that they are probably not the result of chance. Since the burden of proof is always on those who claim to have demonstrated a previously undemonstrated linguistic relationship, it is very surprising that those who have recently tried to demonstrate connections between far-flung language families have not even addressed the question of chance resemblances. This omission calls their entire enterprise into question. (Ringe 1992: 81)

Therefore, insight on what similarities might be expected by chance can be beneficial to the comparativist. Conventional wisdom holds that 5–6 percent of the vocabulary of any two compared languages may be accidentally similar. Ringe explains why chance is such a problem in multilateral comparison:

Because random chance gives rise to so many recurrent matchings involving so many lists in multilateral comparisons, overwhelming evidence would be required to demonstrate that the similarities between the languages in question were greater than could have arisen by chance alone. Indeed, it seems clear that the method of multilateral comparison could demonstrate that a set of languages are related only if that relationship were already obvious! Far from facilitating demonstrations of language relationship, multilateral comparison gratuitously introduces massive obstacles . . . most similarities found through multilateral comparison can easily be the result of chance . . . a large majority of his [Greenberg's Amerind] "etymologies" appear in no more than three or four of the eleven major groupings of languages which he compares; and unless the correspondences he has found are very exact and the sounds involved are relatively rare in the protolanguages of the eleven subgroups, it is clear that those similarities will not be distinguishable from chance resemblances. When we add to these considerations the fact that most of those eleven protolanguages have not even been reconstructed (so far as one can tell from Greenberg's book), and the fact that most of the first-order subgroups themselves were apparently posited on the basis of multilateral comparisons without careful mathematical verification, it is hard to escape the conclusion that the long-distance relationships posited in Greenberg 1987 rest on no solid foundation. (Ringe 1992: 76)

Phoneme frequency within a language plays a role in how often one should expect chance matchings involving particular sounds in comparisons of that language with other languages; for example, 13–17 percent of English basic vocabulary begins with *s*, while only 6–9 percent begins with *w*; thus, given the greater number of initial *s* forms in English, one must expect a higher possible number of chance matchings for *s* than for *w* when English is compared with other languages (Ringe 1992: 5). As Ringe demonstrates, the potential for accidental matching increases dramatically in each of the following: when one leaves the realm of basic vocabulary or when one increases the number of forms compared or when one permits the semantics of compared forms to vary even slightly.

Doerfer (1973: 69–72) discusses two kinds of accidental similarity. "Statistical chance" has to do with what sorts of words and how many might be expected

to be similar by chance; for example, the 79 names of Latin American Indian languages which begin *na-* (e.g., Nahuatl, Naolan, Nambicuara, etc.) are similar by sheer happenstance, statistical chance. “Dynamic chance” has to do with forms becoming more similar through convergence, that is, lexical parallels (known originally to have been different) which come about due to sounds converging through sound change. Cases of non-cognate similar forms are well known in historical linguistic handbooks, for example, French *feu* ‘fire’ and German *Feuer* ‘fire’ (Meillet 1914, quoted from 1948: 92–3) (French *feu* from Latin *focus* ‘hearth, fireplace’ [-k- > -g- > -Ø-; o > ö]; German *Feuer* from Proto-Indo-European **pūr* [< **puHr-*, cf. Greek *pūr*] ‘fire,’ via Proto-Germanic **fūr-i* [cf. Old English *fȳ:r*]). As is well known, these cannot be cognates, since French *f* comes from PIE **bh*, while German *f* comes from PIE **p* (as prescribed by Grimm’s law). These phonetically similar forms for these basic vocabulary nouns owe their resemblance to dynamic-chance convergence through subsequent sound change, not to inheritance from any common ancestral form.⁶ That originally distinct forms in different languages can become similar due to convergence resulting from sound changes is not surprising, since even within a single language originally distinct forms can converge, for example, English *son/sun* (Germanic **sunuz* ‘son’, PIE **sewə-* ‘to give birth’, **su(ə)-nu-* ‘son’; Germanic **sunnōn*, PIE **sāwel-/*swen-/*sun-* ‘sun’); English *eye/I* (Germanic **augōn* ‘eye,’ PIE **ok^w-* ‘to see’; Germanic **ek* ‘I’, PIE **egō* ‘I’); English *lie/lie* (Germanic **ligjan* ‘to lie, lay,’ PIE **leg^h-*; Germanic **leugan* ‘to tell a lie,’ PIE **leugh-*). A sobering example of dynamic chance is seen in the striking but coincidental similarities shared by Proto-Eastern-Miwok and Indo-European personal endings (Callaghan 1980: 337):

	<i>Proto-Eastern Miwok declarative suffixes</i>	<i>Late common Indo-European secondary affixes (active)</i>
1sg.	*-m	*-m
2sg.	*-š	*-s
3sg.	*-Ø	*-t < **Ø
1pl.	*-maš	*-me(s)/-mo(s)
2pl.	*-to-k	*-te

There is another way in which some comparisons encourage greater accidental phonetic similarities to be included in putative cognate sets. It is not uncommon to find a chain of compared forms where not all are equally similar to each other. When in a potential cognate set, say, three forms (F1, F2, F3) are compared from three languages (L1, L2, L3), one frequently notices that each neighboring pair in the comparison set (say, F1 with F2, or F2 with F3) shows certain similarities, but as one goes along the chain, forms at the extremes (e.g., F1 with F3) may bear little or no resemblance (Goodman 1970: 121). A set from Greenberg’s (1963) Niger-Congo illustrates this; he listed: *nyerj*, *nyā*, *nyo*, *nu*, *nwa*, *mu*, *mwa*, where adjacent pairs are reasonably similar phonetically, but the ends (*nyerj* and *mwa*) are hardly so; “the more forms which are cited, the

further apart may be the two most dissimilar ones, and the further apart these are, the greater the likelihood that some additional form from another language will resemble [by sheer accident] one of them" (Goodman 1970: 121).

One need only contemplate Ruhlen's (1994: 183–206) proposed Proto-Amerind etymon **t'ana* 'child, sibling' to see how easy it is to find similarities by chance. The semantics of the glosses range over 'small, person, daughter, woman, old, sister-in-law, brother-in-law, son, father, older brother, boy, child, blood relative, aunt, uncle, man, male, mother, grandfather, grandmother, male of animals, baby, grandchild, niece, nephew, cousin, daughter-in-law, wife, girl, female, friend, old woman, first-born, son-in-law, old man.' While many of the forms cited have some *t*-like sound + Vowel +*n*, others do not share all these phonetic properties. The *n* is apparently not necessary (given such forms as *tsuh-ki*, *u-tse-kwa*), while the *t* can be represented by *t'*, *t*, *d*, *ts*, *s*, or *č* (let us call this the *TV(N)* target template). It is not hard to find forms of the shape *TVN* or *TV* (or more precisely *t/d/ts/s/čV(w/y) V (n/ŋ)*) with a gloss equivalent to one of those in the list above (e.g., a kinship term or person) in virtually any languages, for example, English *son*, German *Tante* 'aunt,' Japanese *tyoonan* 'eldest son,' Malay *dayang* 'damsel,' Maori *teina* 'younger brother, younger sister,' Somali *dállaan* 'child,' and so on.⁷

11 Sound–Meaning Isomorphism

Meillet advocated permitting only comparisons which involve both sound and meaning together (see also Greenberg 1957, 1963). Similarities in sound alone (e.g., tonal systems in compared languages) or in meaning alone (e.g., grammatical gender in compared languages) are not reliable, since they are often independent of genetic relationship, due to diffusion, accident, typological tendencies, etc. In Meillet's (1948: 90) words:

Chinese and a language of Sudan or Dahomey such as Ewe, for example, may both use short and generally monosyllabic words, make contrastive use of tone, and base their grammar on word order and the use of auxiliary words, but it does not follow from this that Chinese and Ewe are related, since the concrete detail of their forms does not coincide; *only coincidence of the material means of expression is probative.* (my emphasis)

12 No Non-Linguistic Evidence

Another valid procedure permits only linguistic information, and no non-linguistic considerations, as DGR evidence (Greenberg 1957, 1963). Shared cultural traits, mythology, folklore, or technologies must be eliminated from arguments for linguistic kinship. The wisdom of this principle is seen against

the backdrop of the many outlandish proposals based on non-linguistic evidence. For example, some earlier African classifications proposed that Ari (Omotic) belongs to either Nilo-Saharan or Sudanic “because the Ari people are Negroes,” that Moru and Madi belong to Sudanic because they are located in central Africa, or that Fula is Hamitic because the Fulani herd cattle, are Moslems, and are tall and Caucasoid (Fleming 1987: 207).

13 Erroneous Morphological Analysis

Where compared words are etymologized into assumed constituent morphemes, it is necessary to show that the segmented morphemes (roots and affixes) in fact exist in the grammatical system. Unfortunately, unmotivated morphological segmentation is found very frequently in proposals of remote relationship. Also, undetected morpheme divisions are a frequent problem. Both of these can make the compared languages seem to have more in common than they actually do.

Illich-Svitych’s (1990) Nostratic ***?äla* ‘negation’ illustrates the problem of unrecognized morpheme boundaries. It depends heavily on Uralic **äla/ela* ‘2nd pers. imperative negative’, but this is morphologically complex, from Proto-Uralic **e-* (**ä-*) ‘negative verb’ + **l* ‘deverbal suffix.’ The other three representatives of this Nostratic set are no help; Illich-Svitych himself indicated that the Karvelian and Altaic forms are doubtful, while Afro-Asiatic **?l/l?* ‘prohibitive and negative particle’ shares only *l*, which cannot match, since Uralic’s *l* is not part of the negative root. In another example, Greenberg compares Tzotzil *ti?il* ‘hole’ with Lake Miwok *talok^h* ‘hole,’ Atakapa *tol* ‘anus,’ Totonac *tan* ‘buttocks,’ Takelma *telkan* ‘buttocks’ as evidence for his Amerind hypothesis (Greenberg 1987: 152); however, the Tzotzil form is *ti?-il*, from *ti?* ‘mouth’ + *-il* ‘indefinite possessive suffix,’ meaning ‘edge, border, outskirts, lips, mouth,’ but not ‘hole.’ The appropriate comparison *ti?* bears no particular resemblance to the others listed. Failure to take morpheme boundaries into account in this example results in not being able to tell ‘anuses,’ so the saying goes, from a ‘hole in the ground.’ The other problem is that of inserted morpheme boundaries where none is justified. For example, Greenberg (1987: 108) arbitrarily segmented Tunebo *baxi-ta* ‘machete’ (a loan from Spanish *machete*, mentioned above); this erroneous morphological segmentation falsely makes the form appear more similar to the other forms cited as putative cognates, Cabecar *bak*, and Andaqui *boxo-(ka)* ‘axe.’⁸

14 Non-Cognates

Another problem is the frequent comparison of non-cognate forms within one family with forms from some other. Often unrelated forms from related

languages, joined together in the belief that they may be cognates, are compared with forms from other language families as evidence for even more distant relationships. However, if the forms are not even cognates within their own family, any further comparison with forms from languages outside the family is untrustworthy.⁹ Cases from Olson's (1964, 1965) Chipaya-Mayan hypothesis illustrate the difficulty (see Campbell 1973). Tzotzil *ay(in)* 'to be born' (actually from Proto-Mayan **ar-* 'there is/are,' Proto-Tzotzil **ay-an* 'to live, to be born') is not cognate with *yaʔ* (read *yah*) 'pain' (Proto-Mayan **yah* 'pain, hurt') of the other Mayan languages listed in this set, though its inclusion makes Mayan seem more like Chipaya *ay(in)* 'to hurt.' Yucatec Maya *čal(tun)* 'extended (rock)' is compared to non-cognate *č'en* 'rock, cave' in other Mayan languages; the true Yucatec cognate would have been *č'eʔen* 'well' (and 'cave of water') (Proto-Mayan **k'eʔn* 'rock, cave'). Yucatec *čaltun* means 'cistern, deposit of water, porous cliff where there is water' (from *čal* 'sweat, liquid' + *tun* 'stone,' cf. Proto-Mayan **to:n* 'stone'). The non-cognate *čaltun* suggests greater similarity to Chipaya *čara* 'rock (flat, long)' with which the set is compared than the **k'eʔn* etymon does.

14.1 Forms of limited scope

Related to this problem is the tendency for DGR enthusiasts to compare a word from but one language (or a very few languages) of one family with some word thought to be similar in one (or a few) languages in some other family. Forms which have clearly established etymologies in their own families, by virtue of having cognates in a number of sister languages, stand a better chance of perhaps having even more remote cognate associations with words of languages that may be even more remotely related than some isolated form in some language which has no known cognates elsewhere within its family and hence no *prima facie* evidence of potential older age. Inspectionally resemblant lexical sets of this sort can scarcely be convincing. Meillet's etymological principle for established families should be an even stronger heuristic for distant genetic proposals:

When an initial "proto language" is to be reconstructed, the number of witnesses which a word has should be taken into account. An agreement of two languages, if it is not total, risks being fortuitous. But, if the agreement extends to three, four or five very distinct languages, chance becomes less probable. (Meillet 1925: 38, quoted from Rankin's 1992: 331 translation.)

14.2 Neglect of known history

Another related problem is that of isolated forms which appear similar to forms from other languages with which they are compared, but when the

known history is brought into the picture, the similarity is shown to be fortuitous. For example, in a set labeled ‘dance’ Greenberg (1987: 148) compared Koasati (Muskogean) *bit* ‘dance’ with Mayan forms for ‘dance’ or ‘sing’ (e.g., K’iche’ *bis* [should be *b’i:š*], Huastec *bišom* etc.); however, Koasati *b* comes from Proto-Muskogean **k^w*; the Muskogean root was **k^wit-* ‘to press down’, where ‘dance’ is a semantic shift in Koasati alone, applied first to stomp dances (Kimball 1992: 456). Only neglect of Koasati’s known history permits the Koasati form to be seen as similar to Mayan. It is not uncommon in proposals of DGR to encounter forms from one language which exhibit similarities to forms in another language where the similarity is known to be due to recent changes in the individual history of one of the languages. In such cases, when the known history of the languages is brought back into the picture, the similarity disappears.

15 Spurious Forms

Another problem is non-existent “data,” that is, the “bookkeeping” and “scribal” errors that result in spurious forms being compared. For example, Brown and Witkowski (1979: 41) in their Mayan-Mixe-Zoquean hypothesis compared Mixe-Zoquean forms meaning ‘shell’ with K’iche’ *sak*, said to mean ‘lobster,’ actually ‘grasshopper’ – a mistranslation of Spanish *langosta*, which in Guatemala means ‘grasshopper.’ While a ‘shell-lobster’ comparison is a semantic strain, ‘shell-grasshopper’ is too far out. Errors of this sort can be very serious, as in the instance where “none of the entries listed as Quapaw [in Greenberg 1987] is from that language,” but rather all are from Biloxi and Ofo (other Siouan languages, not particularly closely related to Quapaw) (Rankin 1992: 342). Skewed forms also often enter proposals due to philological mishandling of the sources. For example, Greenberg (1987) systematically mistranliterated the <v> and <e> of his Creek source as *u* and *e*, although these symbolize /a/ and /i/ respectively. Thus <vne> ‘I’ is given as *une* rather than the accurate *ani* (Kimball 1992: 448).

Spurious forms skew the comparisons.

16 A Single Etymon as Evidence for Multiple Cognates

A common error in proposals of DGR is that of presenting a single form as evidence for more than one proposed cognate set. A single form/etymon in one language cannot simultaneously be cognate with multiple forms in another language (save when the cognates are etymologically related, in effect meaning only one cognation set). For example, Greenberg (1987: 150, 162) cites the same

Choctaw form *ati* in two separate forms; he gives *ti* ‘wing,’ actually *ati* ‘edge, margin, a border, a wing (as of a building),’ under a cognate set labeled ‘feather,’ and then gives *æti* (misrecorded for *ati*) under the set labeled ‘wing.’ In this case the Choctaw form can scarcely be cognate with either one (and cannot logically be cognate with both), since ‘wing’ can enter the picture only if it is a wing of a building that is intended (Kimball 1992: 458, 475).

Closely related to this is the error of putting different but related forms which are known to be cognates under different presumed “etymologies.” For example, under MAN_1 Greenberg (1987: 242) listed Central Pomo *ča[:lč’]*, but the Eastern Pomo cognate *ka:k^h* is given under a different set, MAN_2 (Greenberg 1987: 242) (see Mithun 1990: 323–4).

17 Conclusion

Given the confusion that certain claims regarding proposed DGRs have engendered, it is important to consider carefully the methodological principles and procedures involved in the investigation of possible distant genetic relationships, that is, in how family relationships are determined. Principal among these are reliance on regular sound correspondences in basic vocabulary and patterned grammatical evidence involving “shared aberrancy” or “submerged features,” with careful attention to eliminating other possible explanations for similarities noted in compared material (e.g., borrowing, onomatopoeia, accident, nursery forms, etc.). I feel safe in predicting that most of the future research on possible distant genetic relationships which does not heed the methodological recommendation made here will probably remain inconclusive. On the other hand, investigations informed by and guided by the methodological considerations surveyed here stand a good chance of advancing understanding, by either further supporting or denying proposed family connections.

NOTES

- 1 English translation from Rankin (1992: 324).
- 2 Actually, *tytār* ‘daughter’ is usually held to be a loan from Baltic (cf. Latvian *dukteř-*) rather than Germanic, but this does not affect the argument here, since the question is about Indo-European, not its individual branches.
- 3 Meillet found “general type” of no value for establishing genetic relationships: “Although the usage made of some type is often maintained for a very long time and leaves traces even when the type as a whole tends to be abolished, one may not make use of these general types at all to prove a ‘genetic relationship.’ For it often happens that with time the type tends to die out more or less completely, as appears from the history of the Indo-European

- languages" (Meillet 1925, quoted from 1967: 37.) "Even the most conservative Indo-European languages have a type completely different from Common Indo-European . . . Consequently, *it is not by its general structure that an Indo-European language is recognized*" (Meillet 1925, quoted from 1967: 37–8; my emphasis). "Thus, it is not with such *general features of structure*, which are subject to change completely in the course of several centuries . . . that one can establish linguistic relationships" (Meillet 1925, quoted from 1967: 39).
- 4 The remaining phonetic similarity is not compelling. K'iche' *man* 'negative' comes from *ma* 'negative' + *na* 'now, still.' Many other languages have *ma* negatives (cf. Sanskrit *mâ*, Modern Greek *mi(n)*, putative Proto-North Caucasian **mV*, Proto-Sino-Tibetan **ma*, putative Proto-Nostratic **ma*, Somali *ma*, etc.; cf. Ruhlen 1994: 83).
 - 5 Tunebo [x] alternates with [š]; nasal consonants do not occur before oral vowels; the vowels of the Tunebo form are expectable substitutes for Spanish *e*.
 - 6 Swadesh (1954: 314) made a similar point with respect to similarities among sounds due to convergent developments in sound changes. This underscores the importance of correspondences over sheer similarities in sound, and it highlights the role of phonological typology. Languages with relatively simple phonemic inventories and similar phonotactics easily exhibit accidentally similar words (explaining, for example, why Polynesian languages, with simple phonemic inventories and phonotactics, have been proposed as the relatives of languages all over the world). True cognates, however, need not be phonetically similar, depending on what sorts of sound changes the languages involved have undergone. Matisoff's (1990) example is telling: in a comparison of Mandarin Chinese *ér* / Armenian *erku* / Latin *duo*, all meaning 'two', it is Chinese and Armenian (unrelated) which bear the greatest phonological similarity, but by accident, while Armenian and Latin (related) exhibit true sound correspondences ((*e*)*rk* : *w*) which witness their genetic relationship.
 - 7 Even English *daughter* (Old English *dohtor*, Proto-Indo-European **dhug(h)ater* – or the like: there are problems with the reconstruction) fits in view of such forms as *tsuh-ki* and *u-tse-kwa* in the list.
 - 8 The only other form in this set, Cuitlatec *navaxo* 'knife,' as mentioned earlier, is borrowed from Spanish.
 - 9 It is possible that some of the non-cognate material within erroneously proposed cognate sets may have a more extended history of its own and therefore could turn out to be cognate with forms compared from languages where one suspects a distant genetic relationship. However, such forms do not warrant nearly as much confidence as do real cognate sets which have a demonstrable etymology within their own families and therefore, due to their attested age in that group, might be candidates for evidence of even remoter connections.

5 Diversity and Stability in Language

JOHANNA NICHOLS

It is a textbook truism that some things in language are prone to change more rapidly than others, and that some things are readily borrowed and others are not. For example, high-frequency verbs are less likely to undergo analogical leveling than less frequent ones, and basic vocabulary is less likely to be borrowed than cultural terminology. (For analogy and contact see Anttila, Dressler, Hock, and Thomason, this volume, respectively.) These are cases of relative stability, and they require probabilistic modeling. This chapter is a programmatic inquiry into the different kinds of stability that linguistic elements can exhibit and the different degrees to which they can exhibit them. Stability or instability, it will be shown, is a matter of competing forces, and explaining the uniformity or diversity of reflexes across a set of daughter languages requires tracking separately the item's propensity to be inherited, its propensity to be restructured, its propensity to be borrowed, etc., as well as the carrying power of any potential competitors. Diversity arises when some element is relatively unstable and therefore prone to replacement in various ways. Of course we are far from being able to reduce the different stabilities and viabilities of various linguistic elements to precise numbers, and in any event language change is not entirely deterministic, but the discussion here is intended to spur the kind of cross-linguistic work required to estimate stability and identify recurrent strong and weak points in linguistic structure. For the most part, broad typological categories will be at issue here, although in reality what a language inherits or borrows is not, say, ergativity in the abstract but a particular pattern and its markers (e.g., ergative inflection of nouns with ergative case suffix *-ek*). The Caucasus, with its several language families and many contact situations, is a natural laboratory for surveying stability and diversity, and it provides most of the examples used below.¹

1 Kinds of Diversity and Stability

1.1 *Different kinds of diversity*

Diversity, by the standard definition, obtains when a number of different features, properties, or types are found in a population.

Consider the various major word-order types: SOV, SVO, VSO, etc. A language family is diverse to the extent that the types are all well represented, and homogeneous to the extent that one type predominates. By this measure, the Austronesian, Semitic, and Indo-European families are all fairly diverse with regard to word order, as SOV, SVO, and verb-initial order are all found in all three families. (Maximal diversity would have all basic types represented with about equal frequency, a situation which does not obtain in any language family I know of.) In contrast to these families with diverse word order, Nakh-Daghestanian, another family of a great age, has almost exclusively SOV word order among its daughter languages and is therefore highly homogeneous.

Not only families but also areas can be described as diverse versus homogeneous. The Balkan language area is relatively homogeneous in the word orders, morphologies, and consonant inventories of its constituent languages, while the Caucasus is relatively homogeneous in word order (which is SOV in nearly all of the languages) but quite diverse morphologically and in morpheme and syllable structure. The Pacific Northwest of North America is diverse in all three properties. The languages of New Guinea are quite homogeneous in word order (almost entirely SOV) but phonologically and morphologically diverse. The languages of Australia are strikingly similar in phonology, not greatly different in word order, and moderately diverse in morphology.

These are examples of structural diversity and structural homogeneity. The term “diversity” can also be used of family tree structure and genetic origins. A language family can be described as diverse if it has many high-order branches, and the languages in a geographical area can be called diverse if they represent many different families. This chapter leaves genetic diversity aside and deals only with structural diversity.

1.2 *Different kinds of stability*

In this chapter *stable* does not mean “immutable”; it means “more resistant to change, loss, or borrowing (than other elements of language).” Nothing in language, of course, is truly immutable. In fact nothing even comes close to immutability. Few provable language families are much older than about 6000 years, which means that after not much over 6000 years few things remain sufficiently unchanged to permit detection of their original unity. After the 100,000 or so years representing the age of anatomically modern humanity, we have no way of determining whether all the world’s language families descend

Table 5.1 Three Indo-European features and their stability in selected daughter languages.

Language	1sg. suppletion	Genders	Declension classes
English	Yes	No	No
German	Yes	Yes	Traces
Lithuanian	Yes	Yes	Yes
Russian	Yes	Yes	Yes
Bulgarian	Yes	Yes	No
French	Yes	Yes	No
Albanian	Yes	Yes	In part
Ossetic	Yes	No	No
Armenian	Yes	No	Traces

from a single ancestor or not. Compare this with the record of biological genetics, which is able to trace descent lines back with certainty for millions of years. We do not know and cannot know whether English and Navajo ultimately descend from the same ancestor language of 100,000 years ago (or even more recently), while we do know that humans and chimpanzees descend from a single ancestor species of about five million years ago.

Linguistic stability may therefore seem to be something of a misnomer. Some elements of languages, however, are more prone to change than others, and *stable* is the best term for those that are least prone to change.

1.2.1 Stability of a system in a family

Most Indo-European daughter languages preserve the suppletive stems of the first person pronoun **eǵō*: **me*. Fewer, but still a good many, preserve the inherited gender system or a collapsed version of it with merger of the old neuter and masculine genders. Still fewer preserve the original system of noun declension classes or even the major classes (see table 5.1). We can say that the first person pronoun stem suppletion is very stable in Indo-European, gender is fairly stable, and the declension classes are not particularly stable. A theory of genetic stability will identify and explain these and other more and less stable phenomena in the world's language families, and empirical cross-family surveys will tell us what features actually are most and least genetically stable.

Ergativity provides another example. As will be discussed in more detail below, ergativity is a *recessive* feature (Nichols 1993), that is, a feature which is almost always lost by at least some daughter languages in a family and is not readily borrowed in contact situations. Thus, though not always inherited, when found in a language it is more likely to have been inherited than borrowed. Therefore, ergativity can be an important component of the grammatical signature of a language family: not every daughter language has it, but its mere

presence in several or most languages of the family helps characterize the family and identify languages belonging to the family. Should we call it stable or not? A theory of stability will give us terminology and a descriptive apparatus for various kinds of retention situations.

1.2.2 *Cross-linguistic stability of a type of system*

Agglutinating suffixal morphology, simple syllable structure, vowel harmony, cases, and head-final word order characterize languages of several different families in northern Eurasia. Some of these traits are known to be linked by typological implicational relations, but not all of them (the various implications are discussed in Greenberg 1963; Dryer 1992; Plank 1998). The whole set of traits can be described as stable in northern Eurasia. A full theory of stability should be able to account for where the stability resides (in the syllable structure? in the head-final principle? in cross-categorical relations?) and why it has taken root so firmly in this area but nowhere else.

1.2.3 *Cross-linguistic and inter-linguistic durability of a single element*

There are cases of specific structural traits which seem to be cross-linguistically favored and are stable in families where they are present and prone to spread areally from languages having them to languages lacking them. Accusative alignment is an example; SVO order, in comparison to other VO types, is another. These are the favored, or most frequent, or unmarked types in their categories, and their status has received much theoretical attention over the years. Another kind of cross-linguistic durability arises where small systems of elements are strongly glued together by phonosymbolic or paronomastic resonances, to be discussed below (section 3.2). The formal coding of small resonant systems is likely to be stable if already present, and likely to be borrowed if available, where it is phonosymbolic. A theory of stability can account for this heightened viability and quantify it for purposes of modeling its tendency to spread.

2 Stability in Transmission

2.1 *Inherited and acquired elements*

The normal state of affairs in language transmission is that all elements of language are transmitted, and therefore that they are *inherited* by daughter languages from ancestral languages. Of course, in reality not everything is inherited. In addition to being inherited, elements of language can be *acquired* from various sources in various ways: by borrowing, through substratal effects, and as a result of what I will call *selection*. Selection is the process whereby

elements that embody language universals, cross-categorial harmony, unmarked terms, and other typological desiderata are incorporated into a language. An allophone, allomorph, word order variant, etc. may either expand or retract in function, and evidently the universally preferred, unmarked, and otherwise favored variants are most prone to expand and have a good chance of eventually ending up as the main or sole variant.

An element is *lost* if it is not inherited. A lost element may be replaced (with an acquired one, or with an extended or reanalyzed one), or it may go unreplaced.

In linguistic transmission, unlike biological transmission, acquired elements are inheritable. Whether the ancestral language obtained a given trait by inheritance or acquisition is immaterial as far as further transmission is concerned: the expectation is that new traits as well as old ones will be inherited. For example, Proto-Slavic **melko-* 'milk' was borrowed from Germanic, but it was a Proto-Slavic word nonetheless and was inherited by the Slavic daughter languages just as the ultimately native vocabulary was.

The theory of stability sketched out here attempts to determine the propensity of various elements of language for inheritance, acquisition of various kinds, and loss. What is at issue is inheritance versus non-inheritance from *language to language* and not from generation to generation or individual to individual in the speech-community. Of course, language learning by the individual is the day-to-day mechanism of language transmission and change, but this study deals with the longer-term results, after variation has to some extent been sorted out and we can speak of a norm and a grammar and a daughter language. A time frame of 1000–1500 years is about what it takes for an ancestor language to give rise to a set of clearly distinct daughter languages, and this is probably the shortest period of time to which study of inheritance and non-inheritance can usefully be applied.

Not considered at all in this sketch of stability are two of the most important considerations in all of historical linguistics: sound change and sociolinguistics. Sound change occurs constantly, always threatening to unravel or destroy inherited systems no matter how strong their propensity for inheritance. Sociolinguistic factors of contact and prestige are the major determinants of whether and to what extent borrowing, substratal effects, and selection take place. Modeling stability requires that the inherent inheritability, borrowability, etc. of linguistic elements be determined independent of the particular situations that trigger particular instances of borrowing, selection, etc. Sound change is, however, involved in stability to the extent that high propensity to be inherited entails high propensity to head off the consequences of sound change by restructuring or reanalysis.

2.2 *Measuring propensity to be inherited, acquired, or lost*

The normal situation is what happens in a conservative language: things are inherited from the ancestral language. That is, the probability of inheritance is

Table 5.2 Sample scenarios and hypothetical outcomes

Scenario	Inherit	Borrow	Substratum	Select
(a)	High	Low	Low	Low
(b)	High	High	Low	Low
(c)	Low	High	*	*
(d)	High	Low	High	*
(e)	Low	Low	High	Low
(f)	Low	Low	Low	High
(g)	Low	Low	Low	Low

Notes:

* = unknown or not considered

- (a) The item is inherited in most of the daughter languages.
- (b) The element is borrowed in several of the daughter languages.
- (c) The element is borrowed in many of the daughter languages. If it is borrowed from the same source, the daughter languages will exhibit an acquired resemblance.
- (d) The element is inherited in most of the daughter languages, but replaced in several that have prominent substratal effects.
- (e) The element is unstable in the daughter languages, often replaced though not by borrowing, often retained from a substratum where there was one. If several daughter languages share the same substratum, it will look as though a rare and unstable feature has been independently innovated several times.
- (f) Non-inherited or non-cognate forms in the daughter languages converge (multiple parallel innovation, or similar outputs from different processes or sources).
- (g) Structural change occurs independently in several or many daughter languages: the element is lost and not replaced.

absolutely high overall. In this survey, however, the absolutely high tendency for inheritance will be ignored, and elements will be described as relatively high versus relatively low in their tendency to be inherited.

The different transmission probabilities can be summarized as follows:

- *Inheritance*: High (the default); low.
- *Borrowing*: High; neutral (the default); low.
- *Substratum*: High; neutral?; low. It is not clear whether neutral and low are different, and if so which is default; there has been too little study of substratum.
- *Selection*: High; neutral; low; n/a. (Selection generally operates on forms, or on values of categories, so its applicability depends on what element is at issue.)

Table 5.2 gives some examples of different transmission probabilities and their likely outcomes. To judge genetic stability, assume we are dealing with a family of considerable age with a good number of daughter languages; the effects of the different transmission probabilities make themselves felt in

the statistical distribution of various elements in the daughter languages. To judge areal stability, assume a linguistic area involving languages from several different families; the transmission probabilities make themselves felt in the consistency or diversity of an element in the various languages.

In scenario (a), the element is genetically stable. In the others, it is genetically unstable in various ways and to various extents. In (b)–(e), areal effects can make themselves felt, and in (c) and (e) we have different kinds of areal stability.

Linguistic practice is aware of different propensities to be inherited, borrowed, etc., but it does not take explicit enough cognizance of the fact that transmission is a two-sided or several-sided matter. It is not enough to know only whether an element is likely to be inherited, or whether it is likely to be acquired. To account for the probability of various transmission scenarios in a contact situation, it is necessary to know both the propensity of the item to be inherited and its propensity to be acquired.

2.3 *Stability, viability, etc.*

A number of different kinds of linguistic perseverance can be distinguished and may need to be distinguished terminologically. *Genetic stability* obtains when there is both high probability of inheritance and low probability of acquisition. A genetically stable system or category therefore tends to be retained in a family. High probability of inheritance, borrowing, substratal retention, and/or selection can be termed *viability*. A viable form or paradigm tends to be retained if already present or acquired if available.

The term *recessive* describes features with low probability of inheritance and low probability of borrowing (e.g., ergativity, described as recessive in Nichols 1993). A recessive feature tends to become less and less frequent over time in a family or area.

For a maximally explicit technical terminology, it may prove useful to reserve *stable* for genetic stability and choose a term such as *consistent* for areal stability. Terms such as *dominant* and *persistent* could be used for high propensity to be acquired by borrowing or from a substratum respectively. A generic term may be needed for the two kinds of viability represented by high inheritability and substratal persistence, both of which are kinds of tenacious resistance to other alternatives. A full terminology will not be proposed here, as identification of the phenomena actually in need of labels is best left to emerge from an empirical literature.

2.4 *A full theory of stability and diversity*

The goal of a theory of stability and diversity is to account for the probability of various elements of language to be inherited or acquired, and the various conditions that may hold for particular elements and scenarios. This will include

working out the relative viability of broad structural categories such as word order and alignment, more specific categories such as verb-initial order and ergative alignment, and still more specific form–meaning–structure sets such as (hypothetically) ergative case paradigms of nouns with case suffixes $-\emptyset$ (nominative), $-lo$ (ergative), $-sa$ (dative).

Since stability is never absolute, it can be thought of as the mortality rate or life expectancy of a feature of an ancestral language. It can be modeled as the inheritance rate for ancestor-to-daughter transmission, or (more accurately) as the timespan through which the feature can be expected to perdure in a language family. Life-expectancy distributions are modeled with what is known as *survival analysis*, so called because it models the life expectancies of medical patients after various interventions and under various conditions (see, e.g., Selvin 1995: ch. 11). Survival analysis applied to linguistic transmission would compute, for each element and under each transmission scenario, a probability of loss over a given timespan and the influence of various conditions on this rate of loss. Working out such survival probabilities for linguistic stability even in the broadest terms will be a very large task, for it requires tracing numerous elements of grammar and lexicon through numerous transmission scenarios, each in enough different languages (genetically, structurally, and areally independent) that the proportion of changed and unchanged, inherited and acquired, etc. in each set can be taken with some confidence to represent actual probabilities. This in turn will require thorough comparative historical and descriptive work in many different languages of many different families. The study of any one element might well be monograph- or dissertation-sized. For instance, a survival analysis for ergativity would gather data from as many ergative languages as possible and determine or reconstruct whether the ancestor was ergative; control for family age to the extent possible; examine clause alignment in every descendant of every ergative ancestor and thereby determine the percentage of daughters that inherit ergativity; determine the effect on this heritability of such factors as having mostly ergative neighbors, having no ergative neighbors, split versus unsplit ergativity, ergativity in different parts of speech, etc.; examine cases where ergative languages have descended from non-ergative languages and determine the percentage of languages that acquire ergativity in the various ways; and other relevant factors. Then we would have a basic understanding of the stability of ergativity.

Once the structural picture has begun to assume shape, the still larger task of integrating it with sociolinguistics can begin. Our understanding of the effects of different kinds of language contact on different transmission scenarios has advanced rapidly in recent years, beginning with the publication of Thomason and Kaufman (1988), but this kind of work is still in its infancy, as shown by the fact that most of its statements are categorical rather than probabilistic. Ultimately we can hope to have a full enough understanding of the sociolinguistics of contact situations, the effects of types of contact on transmission, and the transmission propensities of various structural elements to be able to (for example) identify a contact situation as one or another kind of substratum

and as weak or strong and show that the elements retained from the substratum are in fact most prone to be substratally acquired and/or least prone to be inherited. The different propensities can be quantified for purposes of modeling and characterized more loosely when tracing histories of actual languages and actual vocabulary and grammatical elements. A full apparatus of this type will not only improve our ability to describe and explain histories; gaining even an approximate grip on the relative stabilities of some basic elements of grammar would provide useful heuristics, or at least priorities, in searches for deep genetic relatedness.

3 Survey: Relative Stability of Selected Linguistic Elements

In this section several different structural features are surveyed in order to determine their relative propensity for inheritance and acquisition. In every case, what languages stand to inherit (and do tend to inherit, in cases of high stability) is a particular piece of grammar or lexicon with a particular formal exponent, a particular function, and/or a particular systemic status (such as a position in the phonological system). What they stand to acquire is either a particular form–meaning pairing or a typological category in the abstract. As an example of a category in the abstract, when inclusive/exclusive oppositions diffuse areally it is often the abstract opposition, and not a particular inclusive or exclusive pronoun, that spreads (Jacobsen 1980). More research is required to know whether the areal spread of features such as genders and numeral classifiers is the spread of particular forms and categories or of the typological parameter in the abstract. What the historical typologist compares is not particular elements but gross structural features and categories in the abstract. Though these are not what is inherited, and not (or not always) what is acquired, they are the only thing that can be meaningfully compared cross-linguistically, and therefore they are what we must focus on in ranking stability.

3.1 *Basic vocabulary*

Basic vocabulary lists such as the Swadesh 100-word and 200-word lists and the shorter Yakhontov and Dolgopolsky lists (all of these are entries in Trask 1999) are words for which the probability of loss is relatively low. The competing factors for stability of this sort can be tabulated as follows (entries are probability levels):

	Inherit	Borrow	Substratum	Select
Basic vocabulary	High	Low	?	n/a

Given that the probability of inheritance is high and that of acquisition low, the probability of change of meaning is presumably also low.

3.2 *Personal pronouns*

Personal pronouns are on all the lists of relatively stable lexemes. But pronominals (lexical and grammatical) are also prone to analogical reshaping, restructuring due to the pragmatics of deference and respect, phonosymbolic pressures, etc. (Meillet 1948: 89–90 was probably the first to point out that the pronouns of Indo-European languages resemble each other less than cognate nouns and verbs do.) These are all forms of selection. Thus:

	Inherit	Borrow	Substratum	Select
Pronouns	High	Low	Low	Variable

When personal pronouns are viewed not as individual elements but as a set, the stability of the entire paradigm can be affected by its phonological and morphological structure. Alliteration, rhyme, and other phonological linking between elements seem to enhance the entire system's prospects for survival. These properties are examples of what Bickel (1995) calls *resonance*, and they phonosymbolize elements of meaning in the system such as person, number, or case. Resonant pronominal systems have recurrent phonological properties that are probably universals of resonance in small systems: they make crucial use of nasals; and they oppose a labial (often [m]) to a dental articulation. An example of a resonant pronoun system is that reconstructed for Proto-West Finnic and internally reconstructible for Finnish:²

		<i>Singular</i>	<i>Plural</i>
Pre-Finnish	1	minä	me
	2	tinä	te

In Finnish, the singular forms rhyme and the plural forms rhyme; the first person forms alliterate and the second person forms alliterate.

The Nakh-Daghestanian (Northeast Caucasian) personal pronoun system has demonstrably evolved from a less resonant (or entirely non-resonant) system. Table 5.3 shows the pronouns from several daughter languages and the reconstructible consonants. Most of the daughter languages exhibit rhyme, alliteration, and/or shared vowels linking forms together by person, number, or both. The resonant patterns and the resonant devices differ from language to language, however, making it clear that they are all secondary. In Chechen, all forms except the inclusive (which is a neologism) rhyme in the nominative singular and all have a stem with the shape VC in the ergative (the oblique form shown in the table). In Avar, the singular forms rhyme (in the nominative) and all plural forms alliterate; the singular oblique forms, and the plural

Table 5.3 Personal pronouns in selected Nakh-Daghestanian languages

Image Not Available

Table 5.4 Types of resonance in pronominal paradigms in Nakh-Daghestanian

Type of resonance	Nakh	AATs	Lak	Dargic	Lezghian	Total
Singulars rhyme	1	1	0	0	1	3
Singulars alliterate	0	0	0	0	1	1
Plurals rhyme	1	0	1	1	1	4
Plurals alliterate	0	1	1	0	0	2
1st persons rhyme	1*	0	0	0	1	2
1st persons alliterate	0	0	0	0	1*	1
2nd persons rhyme	1*	0	0	0	1	2
2nd persons alliterate	0	1	0	1	1*	3
Person and number both resonant (*)	1	0	0	0	1	2

Note: * marks cases where all four person-number combinations rhyme or alliterate.

forms, have /i/ vocalism in the first person and /u/ in second. Akhvakh has similar patterns, but the alliterating initial in the plural forms is different from Avar. In Tsez, nominative singulars again rhyme; the plural forms have the same vocalism; and the second person forms alliterate. In Lak, the plurals either rhyme or alliterate (the 2pl. forms /zu/ and /žwi/ are from different dialects). In Tabassaran, all forms alliterate and have identical vowels. In Lezghi, all forms rhyme. In Agul, the singular forms and the second person plural rhyme, and the first person plural forms rhyme. In Archi, all end in /-n/ and the plural forms rhyme. The types of resonance are summarized in table 5.4.

Rhyme is the strongest resonance, plurals are more prone to resonate than singulars, and second person is more prone to resonate than first. Thus we see that resonance in the abstract is favored in selection, and particular types and contexts of resonance seem to be especially favored.

In Proto-Nakh-Daghestanian there was little or no resonance: there may have been rhyme in the singular forms, but there was no alliteration, and the plural forms seem to have been entirely unlike each other and unlike the singulars. The daughter languages have innovated these various types of resonance. They have probably borrowed kinds of resonance, or the idea of resonance in the abstract, from each other, but there has been no borrowing of actual pronouns.

The same phonosymbolic resonance properties are found in “mama-papa” vocabulary and even in ordinary words for ‘mother’ and ‘father’ (Nichols 1999). Typically such a set is structured by a minimal opposition of labial to dental (or apical) with one or more of the terms marked by a nasal. The “mama-papa” terms in particular are generally regarded as unstable and not good diagnostics of genetic relatedness (Jakobson 1960). However, their viability appears to be good. The stability and viability of resonance in small systems can be summarized as follows:

	Inherit	Borrow	Substratum	Select
Pronouns in general	High	Low	?	n/a
Resonance in pronouns	High	High	High?	High
Resonance in "mama-papa"	?	High?	High?	High

The literature has noted the central role of nasals and labials in such systems, but has generally not noted that it is the mini-paradigm rather than the individual form that is phonosymbolically marked (Nichols and Peterson 1996). A widespread view is that nasals are common in these systems because they are basic and universally favored sounds (e.g., Jakobson 1960; Gordon 1995; Campbell 1997b). In fact nasals are probably not common in deictic systems *per se*; rather, they are common in phonosymbolically structured small paradigms (which are common but by no means universal in deictic systems). That is, the issue here is properly not frequency and basicness but intra-paradigmatic resonance and cross-linguistic durability.

3.3 *Ergativity*

Rarely do all the daughter languages of an ergative ancestor preserve ergativity; an ergative ancestor language usually gives rise to a mix of ergative and accusative daughters, and sometimes other alignments as well (Nichols 1993). Similarly, in an area where ergativity is an areal feature, not all the languages will have ergativity; some will be accusative (or perhaps have other alignment types). Meanwhile, all-accusative families and all-accusative areas are common. Ergativity is therefore a recessive feature, prone to loss and not prone to diffusion (though the presence of ergative neighbors can evidently favor the retention of inherited ergativity, as ergativity is geographically a cluster phenomenon). Despite this recessivity, ergativity nonetheless has moderate genetic stability, as it is more consistent in families than in areas (Nichols 1995). Ergativity is a decisive example showing that probability of inheritance and probability of acquisition are independent. It seems that ergativity is likely to be retained from a substratum though relatively unlikely to be borrowed, and it is quite unlikely to be spontaneously innovated (Nichols 1993, 1995). Thus the stability factors for ergativity are:

	Inherit	Borrow	Substratum	Select
Ergativity	Low	Low	High?	Low

3.4 *Phonetics and phonology*

3.4.1 *Segments*

Surface phonetic manifestation of phonemes or other more abstract units is often inherited with remarkable consistency, but also frequently borrowed or

Table 5.5 Syllable and root canons for the three indigenous languages of the Caucasus

Language	Canon
Nakh-Daghestanian	C*V(R)(C)
Kartvelian	S ¹
Northwest Caucasian	C ¹ (V)

Notes: All are reconstructed or abstract canons for the protolanguage or the whole family.

C* = alternating consonant.

S¹ = one or more segments.

C¹ = one or more consonants.

substratal. Abstract sound patterns, on the other hand, can be genetically stable. Certain favored sounds are found in nearly all languages, and they must be favored targets of selection. The possibilities, using these assumptions, can be summarized as follows. All fates have high probability; there is little predicting what will be the outcome of a particular case of contact, sound change, or dialect split:

	Inherit	Borrow	Substratum	Select
Phonetics	High	High	High	Varies; sometimes high
Sound pattern	High	Low?	High?	Low?

3.4.2 *Abstract canon form for syllables or morphemes*

The Caucasus is a linguistic area where languages of different families interact areally, and where in addition there is a traceable and datable history of immigration. The various families have distinctive canons of syllable and morpheme structure, allowing any borrowing or change to be easily identified. Root structures of the three indigenous families are shown in table 5.5.

The Nakh-Daghestanian canon is quite simple, with very few consonant clusters and many open syllables. The vowel is often variable, likely to undergo ablaut,umlaut, or other alternation. The initial consonant is mutable in many daughter languages, changing regularly in verbs and some adjectives to mark gender agreement, prone to contamination and replacement in nouns under the influence of the noun's gender, and in all major word classes subject to occasional replacement creating sets of cognates with different initials. The Kartvelian canon, though highly constrained, allows complex and unusual consonant clusters and makes very little difference between consonants and vowels in the positional possibilities. (The minimal instantiation of S¹ as a monosegmental root occurs only in verbs. Other parts of speech generally require at least two segments and at least one vowel.) The Northwest Caucasian canon is even more distinctive, consisting of only an onset (which is often complex, and

the possible consonant sequences are again numerous and unusual, though tightly constrained).

Despite considerable areality affecting the three families, the syllable and morpheme canons remain family-specific. The Nakh-Daghestanian family is at least 6000 years old and probably more, and syllable and root canons are similar in all the daughter languages; the only regular exception is that vowel elision has created some initial clusters in Lezghi (e.g., *k'rab* 'bone,' cf. Rutul *q'yryb*, Kryts *k'ärap'*, Budux *k'erep'*; all of these languages belong to the Lezghian branch of the family) and Nakh (Ingush *taxan*, Chechen *taxana*: Batsbi *txa* 'today'). Kartvelian is about 4000 years old, and the canon is very similar in all four daughter languages. The age of Northwest Caucasian is unknown but considerable, and the canons of the daughter languages are again very similar. These three family histories suggest that syllable and morpheme canons are very resistant to outside influence and are transmitted intact for millennia. Not surprisingly, the syllable and morpheme structures of Ossetic (an Iranian language which has probably been in or near the Caucasus for about three millennia) and Karachay-Balkar (a Turkic language which has been in the highlands for about 500 years and in or near the Caucasus for just over 1000) remain unswervingly Indo-European and Turkic respectively.

There are, however, linguistic areas where similar syllable and/or morpheme structure canons characterize languages from different families. In Southeast Asia, languages from several different languages have simple morphologies and a sesquisyllabic syllable/morpheme structure with tones and/or phonation types (Matisoff 1999). In northern Eurasia, languages from different families have agglutinative morphology, vowel harmony or other intersyllabic distributional constraints, and a simple syllable canon with much neutralization of contrasts at root and (especially) word edges. In the American Pacific Northwest, languages from different families have complex consonant systems and complex syllable structures with numerous and extensive consonant clusters both root-internally and across morpheme boundaries. In southern Africa, languages of different families belong to the structural type known as "click languages": these have complex consonant systems including clicks, complex syllable onsets including clicks with various coarticulations, and a root canon in which clicks occur only, and often, initially in major-class roots. (For clicks and click languages see Ladefoged and Maddieson 1996: 246ff.) Clicks have been borrowed into some neighboring southern Bantu languages, mostly in loanwords, but the syllable and morpheme type of the click languages has not been borrowed: in the Bantu languages clicks occur in non-initial as well as initial position in roots, with few or no coarticulations, with low frequency, and at fewer points of articulation than in the click languages (Herbert 1990a, 1990b).

The areality of syllable and/or morpheme canons in Southeast Asia, northern Eurasia, and the American Pacific Northwest shows that syllable and/or morpheme canons can be acquired and that borrowing and substratum can reshape syllable and/or morpheme canons to create areality. On the other

hand, in the Caucasus and in southern Africa syllable and morpheme canons resist borrowing, when other phonological properties do spread areally. Strikingly, in southern Africa clicks – one of the world’s rarest sound types – are borrowed into (non-click) Bantu languages but the syllable and morpheme canon built around them in the click languages is not borrowed; here is a case where phones are more prone to spread than canons. In the Caucasus, unusual and/or recessive features such as ergativity, complex consonant inventories, and pharyngeal consonants spread areally, while syllable structure is transmitted with great faithfulness within families and shows virtually no tendency to be borrowed.

The votes, then, are split on the question of whether syllable and/or morpheme canons are genetically stable or not, easily acquired or not. The spread of the simple syllable type in northern Eurasia might be a case of durability or selection favoring a cross-linguistically common type. The Southeast Asian canon, however, equally areal, is diverse and cross-linguistically unusual, and therefore its spread is unlikely to reflect durability or selection. The canons resistant to spread in the Caucasus include the relatively simple Nakh-Daghestanian one, the complex Kartvelian one, and the rare, even unique Northwest Caucasian one. There is thus no obvious correlation between simplicity of canon and propensity to be borrowed, though there must surely be some favored and disfavored structural types. Until a larger survey is undertaken, all that can be said is that syllable and/or morpheme canons have high propensity to be inherited and variable propensity to be borrowed or acquired in substratum situations, the variability depending on factors still unknown:

	Inherit	Borrow	Substratum	Select
Syllable canon	High	Variable (?)	Variable ?	Variable ?

3.4.3 *Chain shifts of vowels*

Vowels, especially long vowels, are prone to undergo chain shifts, and there is a rough preferred directionality to such shifts, with front vowels tending to be raised and back vowels tending to accommodate those changes (Labov 1994; Gordon and Heath 1998). (Gordon and Heath 1998 find a sex-based motivation for such changes: women are likely to lead in the raising of front vowels, men in any shifts involving backing and/or lowering.) In the terms used here, raising of front vowels is favored in selection; it is probably prone to be acquired in borrowing and from a substratum; and any tendency toward it is likely to be inherited, producing cases of drift where the tendency is in its infancy at the time of proto-language break-up. This is a case where a natural phonetic change has high viability whatever its source:

	Inherit	Borrow	Substratum	Select
Front vowel raising (female-led)	High	High	High	High

3.5 Numeral classifiers

Numeral classifiers can be defined as a set of forms required in a phrase consisting of a numeral and a quantified noun; the choice of classifier is determined by the quantified noun and often, but not necessarily, reflects shape and similar properties of the noun. Numeral classifiers are recessive in that none of the families surveyed in Nichols (1995) has numeral classifiers in all of its daughter languages. In only one area, Southeast Asia, were they found in all of the sample languages. Numeral classifiers occurred in non-zero frequencies in only three of ten families surveyed there, but in five of ten areas (average frequencies were nearly the same – 53 percent versus 54 percent – for the three families and the five areas). However, four of the families, but six of the areas, had representatives in the Pacific Rim zone, which is the only place where numeral classifiers are found, and this Pacific Rim bias of the areal sample is probably responsible for the higher showing in areas than in families.

The Pacific Rim distribution of numeral classifiers is discussed in Nichols and Peterson (1996). Numeral classifiers are found only on and near the Pacific coast in a circle extending (to begin in the south) counterclockwise from northern coastal New Guinea through island and mainland Southeast Asia, in coastal northern Asia, and from southern Alaska nearly to Tierra del Fuego. Several different structural features have Pacific Rim distributions, but numeral classifiers are the clearest in terms of both frequency within this macro-area and apparently categorical absence outside of it (categorical in the sample and, to the best of my knowledge, in general).³ Nonetheless, their frequency in this macro-area is not high: only 25 percent of the languages in the entire Pacific Rim population in my worldwide sample have numeral classifiers. The difference between these frequencies and the zero frequencies of the rest of the world is statistically significant, however, showing that the distribution cannot safely be dismissed as due to chance. Numeral classifiers are a recessive areal and genetic feature of the Pacific Rim and, though recessive, a very strong marker of that area, as they are found nowhere else.

Numeral classifiers are genetically recessive, and therefore do not have a high probability of inheritance. They are areally recessive, and therefore do not have a high probability of borrowing; nonetheless, they are a strong macroareal marker and must therefore have some notable probability of borrowing. Their worldwide distribution, with zero incidence outside the Pacific Rim macro-area, rules out any appreciable propensity for selection:

	Inherit	Borrow	Substratum	Select
Numeral classifiers	Not high	Not high	?	Nil

3.6 Genders

Gender classes of nouns are extremely long-lived in language families. (I follow Corbett 1991 in using the term *gender* for all kinds of agreement classes of

nouns.) The Indo-European gender system survives in most of the modern Indo-European languages spoken in Europe. The formal marking has undergone considerable changes: in the Romance languages, German, Bulgarian and Macedonian of the Slavic family, Albanian, and Greek, the salient locus of agreement is now the article. Still, fundamental to gender agreement is the inherited change in adjectives, corresponding to what was once a change from *o*-stem to *a*-stem declension class. The gender system is either the three-way masculine/feminine/neuter opposition of late Proto-Indo-European or a two-gender system with masculine and neuter collapsed into one (as in Romance and Baltic). The genders of some nouns have changed, but some still preserve their ancient gender. Thus the gender system as a whole – the agreement marking, the classes, and the genders of individual nouns – can be said to have survived for millennia in several different branches of Indo-European.

On the other hand, the Indo-European languages preserving genders are mostly neighbors of each other and found in Europe. Gender is a cluster phenomenon (Nichols 1992a: 130–2), a minority feature worldwide whose tokens mostly cluster in adjacent or nearby languages. It must be, therefore, that the inheritability of gender is not maximal and is increased if neighboring languages also have genders.

The Niger-Kordofanian language family is probably older than Indo-European,⁴ and most of its daughter branches have preserved large parts of its elaborate system of gender classes (the prototypical example being the concord classes of Bantu languages, marked by prefixal agreement on verbs and other agreeing words and also by prefixation on the gender-bearing noun itself). (For some examples see Williamson 1989: 38–9.) The system is unusual in its elaboration, yet it is inherited by impressively many daughter languages. (The system has figured crucially in the demonstration of genetic relatedness of Niger-Kordofanian and is still the most visible single marker of the family. See Greenberg 1963; Williamson 1989.) The daughter languages are mostly compactly distributed over a large part of western, central, and southern Africa, and many of the other language families of Africa also have gender systems (albeit smaller and formally different ones), so inheritability has probably been favored by neighboring gender languages. Thus the history of the Niger-Kordofanian gender system supports what is shown by Indo-European: gender is genetically quite stable in a cluster situation, and at least moderately stable elsewhere.

Afro-Asiatic is so far the oldest firmly demonstrated language family, with daughter branches which are themselves of Indo-European-like age. All branches of the family have a minimal masculine/feminine gender system whose exponents (their marking in particular agreement contexts, gender syncretism in the plural, and the syncretism of its marking with a singular marker) are consistent in several branches. As with Niger-Kordofanian, the consistency is great enough that the system of gender and number marking virtually suffices to prove genetic unity for several branches of Afro-Asiatic (Greenberg 1960). In addition, the gender of particular nouns (or noun glosses)

Table 5.6 Gender classes in Nakh-Daghestanian

Gender	Marker	Typical membership
1	w or labialization	Male human
2	j (occasionally r)	Female human
3	b	Some animals and some others
4	d (or *r)	Chiefly inanimates
5	j	Various (animate and inanimate)

Note: Retention hierarchy: 2 and 3 > 1 > 4 > 5

is remarkably consistent across all branches, regardless of whether the words are cognate (Newman 1980: 19–20).

The Afro-Asiatic languages have a relatively continuous distribution (or at least several of the branches do), and gender systems are sufficiently common in Africa that many of their non-Afro-Asiatic neighbors also have genders. Thus Afro-Asiatic is a third case showing high stability of gender systems where neighboring languages, including nearby sisters, also have gender systems.

Nakh-Daghestanian (Northeast Caucasian) is another family of great age with consistently preserved gender systems. There are from two to five agreement categories; most languages have three or four, and a few have lost gender entirely. The typical exponents and approximate proto-exponents of the classes are shown in table 5.6.⁵ The gender classes form a hierarchy of decreasing propensity to be preserved, shown in the note at the bottom of the table.

In the most transparent systems (those of the Nakh and Avar-Andic-Tsezic branches), gender markers are prefixed to verbs and adjectives. Only some verbs and adjectives have gender agreement (about 30 percent of the roots in Chechen, a majority in Avar; a small minority of adjectives in Chechen, probably a majority in Avar). They may additionally be suffixed to participles and adjectives (resulting from suffixation of an earlier copula or auxiliary to which they were prefixed); this, along with their prefixation on auxiliaries used to form compound tenses, means that many inflected verb forms show gender even though the root itself does not. In less transparent systems such as those of the Dargic and Lezghian branches, gender is marked by infixation or ablaut in the verb root. Agreement is on the ergative pattern, with the nominative S/O. Tables 5.7–5.9 show gender markers in three of the languages.

The thirty-odd Nakh-Daghestanian languages are compactly distributed in the eastern Caucasus; nearly all have sisters as neighbors, and many have only sisters as neighbors. This is then another family of great age in which the gender system – exponents, set of classes, distribution of classes across the lexicon – is very stable in a set of adjacent sister languages.

In all four of these families, what is retained for millennia is not just the gross typological property of having genders, but a family-specific gender

Table 5.7 Gender agreement markers in Ingush (Nakh branch)

PND gender	Ingush		
	Gender	Prefix: sg.	Prefix: pl.
1/2	Human	v (masc.)/j (fem.)	d (1st-2nd persons)/b (3rd)
3	B	b	d (a few b)
4	D	d	d
5	J	j	j

Table 5.8 Gender agreement markers in Archi (Lezghian branch) (singular only)

Gender	Prefix	Infix in root	Infix in suffix	Suffix
1	w	w	w	w
2	d	r	r	r
3	b	b	b	b
4	Ø	Ø	t'	t

Source: after Kibrik (1994: 308)

Table 5.9 Gender markers in Budukh (Lezghian branch) (verbs) (singular only)

Gender	Verb type		
	Type 1	Type 2	Type 3
1	Ø	Ø	r
2	r	rV	r
3	v	vV	b
4	Ø	Ø	d
<i>Examples:</i>			
	'be'	'break'	'swell up' (all in durative aspect)
1	jyχər	ch'aqu	synt'ən
2	jyrχər	ch'oroqu	synt'ən
3	juχor	ch'ovoqu	sunt'on
4	jyχər	ch'aqu	synt'ən

Source: following Alekseev (1994: 276ff)

Notes: All are infixes. V = harmonizing vowel. Some phonological rules apply.

system complete with markers, an inventory of gender classes, contexts of agreement, and distribution of the genders across the nominal lexicon. For genders, with their clear formal exponents, it is very obviously not the abstract typological feature but particular form–function pairings that are transmitted from ancestor to daughter language. On the other hand, it is not clear whether survival of gender in cluster situations is favored by the presence of a cognate gender system in neighboring (sister) languages, or simply by the presence of gender in the abstract.

If gender is indeed of high stability only in clustered languages, then it should often be the case that languages that lose gender are neighbors of each other and/or have non-sisters as neighbors. This is true in Nakh-Daghestanian, where three languages of the Lezghian branch have lost genders: Lezghi, which shares its large southern border with Azeri (a Turkic language which lacks gender); Agul, which is next to Lezghi; and Udi, the only language of the family which has no neighboring sisters (it is spoken in two small patches, one in Azerbaijan and one in Georgia). That clustered loss of gender is not simply a matter of borrowing (of non-gender from neighboring languages) is indicated by the fact that it does not go in the other direction: languages without genders do not seem to readily borrow genders (either gender in the abstract or a particular gender system) from their neighbors. I know of no language in all of Eurasia which has acquired gender by diffusion.

Gender, then, is genetically somewhat recessive, of high stability only when reinforced by gender systems in neighboring languages. On the whole, gender systems appear quite resistant to borrowing. There is no reason to believe that they are favored by selection. There must be factors or circumstances that favor the rise of gender systems, but those factors are not commonly encountered. (Numeral classifiers have developed gender-like agreement in the upper Amazon (Payne 1987), but this development is not common and in any case can hardly be invoked to explain the gender systems of Africa, western Eurasia, and Australia, where numeral classifiers are unknown.) Gender, like ergativity, is a puzzle: most of its tokens are the result of inheritance, and even those need outside help to survive; it is easier to explain its loss than its rise. Empirical cross-linguistic work on the origins of gender systems is needed. Otherwise, if gender can only be inherited but not acquired, and even inheritance requires favorable conditions, there is no way to explain how any languages have gender:

	Inherit	Borrow	Substratum	Select
Gender	Not high ^a	Low	?	Nil ?

a Higher when one or more neighboring languages have gender systems.

3.7 *Inclusive/exclusive oppositions*

A minority of the world's languages have inclusive/exclusive oppositions in first person plural pronouns. Most of those are in Australasia and the Americas:

nearly all the languages of Australia have the opposition, and about half of those of the Americas. In Africa and western Eurasia it is rare. The inclusive/exclusive opposition proved to be genetically the most stable of all the features tested in Nichols (1995). On the other hand, Jacobsen (1980) shows that it has an appreciable propensity to be borrowed (or areally spread in some fashion; some of the cases may be substratal).

When the inclusive/exclusive opposition is inherited, it is not the opposition in the abstract that is inherited but particular inclusive and exclusive markers. When it is borrowed, however, it is often the opposition in the abstract that is borrowed, and a form is coined using native resources (Jacobsen 1980).

The entry for substratum in the schema below is based on the single example of Nakh-Daghestanian. As mentioned in section 3.2, Proto-Nakh-Daghestanian had only a single reconstructible first person plural pronoun, though the daughter languages mostly distinguish inclusive/exclusive, and the Proto-Nakh-Daghestanian first person plural root surfaces as exclusive in Nakh but inclusive in Daghestanian. The inclusive/exclusive opposition was innovated or acquired just barely after the Nakh-Daghestanian split, and the split in turn seems to have occurred as early Nakh-Daghestanian entered the Caucasus. I assume that early Nakh-Daghestanian speech spread by language shift, and that features acquired early in the spread – like inclusive/exclusive – result from substratal influence. There is no surviving language or family in the area from which the opposition might have been borrowed, a situation in which historical linguists usually invoke substratum.

Worldwide, the macro-areal frequency of inclusive/exclusive oppositions varies greatly, from near-zero in Africa and western Eurasia to around 50 percent in the Americas to nearly 100 percent in Australia. The opposition is the clearest and most prototypical exemplar of an east-to-west global cline, reflected in many typological features, in which the western Old World on the one hand and Australasia plus the southern Americas on the other stand at opposite poles (Nichols 1992a: 208–17). This great variation and clinal distribution are evidence that its selective value is near nil: if there were any appreciable tendency for it to be spontaneously innovated, its worldwide frequency would be more even:

	Inherit	Borrow	Substratum	Select
Inclusive/exclusive	High	Appreciable	High?	Low

3.8 *Word order*

Word order is well known to be a common areal feature (some of the works dealing with word order as an areal feature include Heine 1976; Masica 1976; Chew 1989; Campbell et al. 1986). Of the 26 features surveyed in Nichols (1995), word order was the only one to emerge as areal and not genetic on all counts performed. There is reason to believe, though, that different word orders have

different degrees of stability. Verb-final word order emerges as the most common in nearly all cross-linguistic surveys. It is near-exclusive in several linguistic areas: the Caucasus, interior northern Eurasia, New Guinea. It is quite consistent in a large number of families. Of all word orders it is most robustly distributed and most independent of other structural features (Nichols 1992a: 93–5). Verb-final order must therefore be a target of selection.

SVO order is also well represented worldwide, dominant in some linguistic areas (the Balkans, western Europe, Southeast Asia) and some macro-areas (Africa and western Eurasia, Australia). It seems to be associated with the isolating morphological type. It has diffused from Europe into the westernmost Finno-Ugric languages (Finnish, Hungarian), for which the inherited order was verb-final.

Verb-initial order is infrequent worldwide, attested chiefly in western Europe and northern Africa (Gensler 1993) and around the Pacific Rim, especially in the Americas (Nichols 1998). In the families where it is well attested, it competes with SVO and (less frequently, under local areal pressure) SOV in Afro-Asiatic, Austronesian, and Mayan. When well represented in old and widely spread language families, paradigm examples of which are Afro-Asiatic and Austronesian, verb-initial order is never exclusive. It is found in a variety of different families only in western America and (to a lesser extent) north Africa, and both its retention in these areas and its loss elsewhere are attributable to areal factors. In short, verb-initial order appears to be genetically recessive, stable only when reinforced by neighboring languages, areal in its distribution yet not known to be widely borrowed. Because it is recessive, it is a salient part of the grammatical signature of the families in which it recurs:

	Inherit	Borrow	Substratum	Select
<i>Word orders:</i>				
SOV	High	High	High ?	High
SVO	High?	High ^a	?	?
Verb-initial	Low ^b	Low	High ?	Low

a High in comparison to verb-initial order, less high in comparison to SOV.

b Unless retention is favored by areal pressure.

4 Two Population Histories Examined from this Perspective

Working out the stabilities of different linguistic features will explain more than language change. Languages, language families, and areal populations are characterized by whole sets of features, and the fates of these sets will help elucidate some now-problematic questions of language history and prehistory.

Here, continuing the programmatic slant of this chapter, it will be shown how the stability of features characterizing areal populations can be used to reconstruct the origin and paleosociolinguistics of the whole population.

4.1 *The Caucasus*

Several areal or potentially areal features of the Caucasus have been discussed here: resonant personal pronouns have high viability (section 3.2), ergativity is recessive and more often inherited than acquired (section 3.3), syllable and morpheme structure is genetically relatively stable (section 3.4.2), and verb-final word order has high viability (section 3.8). The well-known complexity of consonant systems in the Caucasus should be genetically stable as a matter of sound pattern but prone to diffusion sound by sound (section 3.4.1). Features found throughout the Caucasus and in all three indigenous families are ergativity, complex consonant systems with ejectives, and verb-final order. Of these, ergativity and consonant system type are generally inherited, and they reconstruct independently for the three proto-languages; their origins are curious, but there is no evidence that their cross-family distribution is due to contact. (Ergativity has not spread at all to the non-indigenous families of the Caucasus. Ejectives have appeared sporadically in Ossetic, the longest-resident non-indigenous language, but nowhere else.) Verb-final order is a high-viability feature and therefore of little diagnostic value. Resonant personal pronouns are a high-viability feature, but have not spread outside of the Nakh-Daghestanian family. Syllable and morpheme structure are genetically stable and sharply different in the three indigenous families.

Thus there would appear to be less areality in the Caucasus than is generally believed. The Caucasus-wide features are unlikely to be due to contact; features which might, if areally shared, be good diagnostics of long-term contact (resonant personal pronouns, inclusive/exclusive pronouns) are family-specific; each family has its distinct grammatical profile. The Caucasus is a prototypical high-diversity area, but it is not a linguistic area or Sprachbund in any usual sense.

4.2 *The Pacific Rim population in the Americas*

The native languages of the Americas can be grouped into two large areal populations: an older, pan-American population characterized by high frequencies of inclusive/exclusive pronouns and head marking (especially the radically head-marking type, endemic to the Americas); and a younger (post-Pleistocene) overlay running the length of the Pacific coast and marked by personal pronoun systems with /n/ as first root consonant in the first person and /m/ in the second person, true case inflection, identical singular and plural stems in pronouns, verb-initial (or more generally VS) word order,

numeral classifiers, tones, and other features. This younger stratum can be called the Pacific Rim population; outside of the Americas it extends nearly the entire length of the Pacific coast in Asia and Australasia. The Pacific Rim markers in the Americas are not evenly distributed through the Pacific Rim population, but have strong affinities and non-affinities for each other and sort out accordingly into two sets: one with *n-m* pronouns and true cases, and one with verb-initial order and numeral classifiers. The affinities and non-affinities are not inherent grammatical ones but accidental associations, as shown by the fact that they characterize only the American Pacific Rim population but not the Asian one. This arbitrary clumpiness of grammatical features is one of the pieces of evidence for the younger age of the Pacific Rim stratum in the Americas. (The American populations are described in Nichols and Peterson 1996; Nichols 1998, and other sources referred to there.) The stabilities for these features are shown in table 5.10 (the two Pacific Rim feature sets are labeled A

Table 5.10 Likely stability and viability values, for features defining linguistic strata in the Americas

	Inherit	Borrow	Substratum	Select
<i>Pacific Rim group A:</i>				
<i>n-m</i> resonant pronoun system	High	High	?	? ^a
sg. = pl. pronoun stems	High	Varies	?	Varies
same, with resonance	High	High	?	High
true cases	High	Low	?	?
<i>Pacific Rim group B:</i>				
VS word order	Low ^b	Low	High? ^c	Low
Numeral classifiers	Not high	Not high	?	Nil
<i>Pacific Rim, general:</i>				
Tones ^d	High ^b	High?	?	?
<i>Pan-American:</i>				
Inclusive pronouns	High ^b	Appreciable	High?	Low?
Consistent head marking ^d	High? ^{bt}	Not high	?	?

Notes:

n-m pronouns: paradigm with /n/ as root consonant in first person singular, /m/ in second person singular. sg. = plural pronoun stems: identical stems in singular and plural personal pronouns (surveyed on first person). nil = very low, near-nil.

a Resonance in general has high selective value, but the specific *n-m* system is unlikely to have particularly high selective value.^o

b Favored by areal pressure.

c Based on the fact that insular Celtic has acquired verb-initial word order as part of a typological package unlikely to have been acquired in regular borrowing and therefore just possibly substratal. See Gensler (1993) for the package of features, its acquired nature in Celtic, and the very low likelihood that it is borrowed in Celtic.

d Not discussed above. Other entries justified in section 3.

and B). We need to know whether these two strata are likely to be genetic, areal, or other, and more generally what can explain the geographical distribution of structural features in the Americas.

Pacific Rim group A is marked by two high-viability features, both connected to resonance: *n-m* pronoun systems and identical singular and plural pronoun stems. In principle, some of the language families displaying these systems are likely to be ancient sisters, but not all of them. The combination of high inheritability and high viability in its markers suggests that the ancestral Pacific Rim A population was small and the scope of its identifying features has expanded by a combination of family increase and (mostly) acquisition of various types. The appearance of the features in a number of different families over a large area bears on sociolinguistics, indicating that the immigrants were sociolinguistically dominant. The sociolinguistic dominance held only within the Pacific Rim area, as the features have not spread outside the area. Thus the ancestral Pacific Rim A population must have been a small one fortunate to possess some cultural advantage that enabled it to expand and spread its influence far along the coast.

Pacific Rim group B is marked by two low-viability features. The association of these is not grammatically motivated and must reflect their accidental co-occurrence in the ancestral language or population. In view of the low inheritability and low (or at least non-high) viability of the group B features, the relatively large number of attested exemplars is likely to have been derived by population growth (stock increase and language shift) and profound influence (rather than ordinary diffusion), and it is likely to represent a fraction of the exemplars that could have been expected for more stable features. That is, group B is likely to be the detectable fraction of an unsuspected larger population of languages that descend from a small colonizing population plus the neighbors that became profoundly influenced by that population.⁷

This outline of population history is provisional and only as good as the stability values tentatively assigned to the markers of the American language populations. I believe it shows that an account of stability can elucidate matters of prehistory that could not otherwise be detected. There is also a conclusion to be drawn about reconstruction: recessive features are among the strongest candidates for reconstruction to proto-languages.

5 Conclusions

Several scholars have ongoing research programs that can contribute much of interest to understanding of stability. Johanson (1992: esp. 195ff, 1993, 1999, and other works) traces various contact phenomena in Turkic and shows how structural factors in the donor form make it more or less prone to copying, how structural properties of the borrowing language facilitate or inhibit copying, and what actually occurs in borrowing. Field (1998), an in-depth study of

borrowability in general and in Mexicano (borrowing from Spanish), works out principles of compatibility and incompatibility of linguistic systems and a hierarchy of borrowability including such considerations as content versus function words, word versus affix, etc. In terms of stability, these are all factors that directly influence the likelihood of borrowing and therefore the survival rate of the ancestral forms that are susceptible to borrowing. It seems likely that some of them might also actively influence inheritability and/or selection, particularly such things as transparency and opacity of forms; Johanson relates borrowability to ease of L1 learning by children.

Bickel (1999, 2001, 2002, forthcoming) lays the groundwork for a cross-linguistic study of genetic stability, demonstrating (1999) the profound genetic stability, even in the face of intense contact and areal convergence, of constraints on how participant roles are mapped onto clause morphosyntax. The abstract constraints have as their consequences such things as how agreement is controlled, the NP density of clauses, etc,

Maslova (2000) gives mathematical models for the propensity of linguistic types to be changed over a given timespan and the probabilities of transition from type to type as daughter languages are generated. She explicitly accounts separately for both the probability that the new type will be acquired and the probability that the ancestral one will be inherited. Her concern is to show that these probabilities of change and non-change are a better reflection of typological preferences than simple cross-linguistic frequencies are.

There is still much empirical work to be done, language by language, family by family, area by area, feature by feature, and model by model – and it is not grindwork. The works just enumerated are research programs most of which have begun in close empirical studies, some of them by very young scholars, and they show that empirical work on stability and non-stability can yield rich theoretical and comparative dividends.

We can conclude by considering how diversity arises in families and in areas. In families, diversity increases through contact, especially with different languages, when features of high borrowability replace inherited features. Diversity also arises when the ancestral language happens to have several features of low inheritability, which predictably fail to be transmitted in several daughter languages.

In language areas, diversity increases when the areal features spread widely but are not especially prone to be inherited and are therefore lost over time and replaced in different ways in a number of languages in the area. And of course, apart from all questions of stability, diversity can increase through immigration of new languages, genetically and/or typologically diverse, into the area.

Diversity can also increase in an area when there is areal pressure but some of the areal features do not have especially high propensity to be borrowed, and as a result do not spread uniformly through the area. A possible example is verb-initial order in Mesoamerica, which is found in over half of the languages (15/27) and 5 of 10 families in the areal sample of Campbell et al. (1986). By the criteria of Campbell et al. this attestation does not suffice to

make it a proper areal feature, and the more general notion of non-verb-final order is proposed there as an areal feature. From a comparative perspective, however, its unusually high frequency in the area (relative to its worldwide low frequency) gives it high value as part of the area's signature. Though taking this kind of statistical approach to areal features is not standard practice, verb-initial order in Mesoamerica can be held up as an excellent example of a recessive areal feature.

NOTES

- 1 Research on languages of the Caucasus, particularly Chechen and Ingush, has been supported by NSF (SBR 96-16448) and IREX (1989, 1984, 1981, 1979).
- 2 The only difference between Pre-Finnish and Finnish is that *t regularly becomes /s/ before *i, so modern Finnish has 2sg. *sinä*.
- 3 In the survey of Nichols and Peterson (1996) and in my own database, the coastal and near-coastal area in any continent is defined as the area between the coast and the far slope of the major coast range. In the Americas, the major coast ranges are the Andes, the Sierras and Cascades, and (in Canada and Alaska) the Rockies. Where there is no coast range, as in much of mainland Asia, the area extends inland to the nearest major mountain range (e.g., for Southeast Asia, the eastern Himalayas). The linguistic features of the Pacific Rim population also extend farther inland in such places.
- 4 Here and below, when a family is described as "old" or "of great age," it means that much time has elapsed since its break-up. In this sense of "old" and "age" there can be no question of the age of individual languages but only of families: if age is time since dispersal, individual languages do not have age.
- 5 This describes the singular forms only. In some languages one or more of the singular genders has two different plural forms (the choice determined by the noun), and many grammarians set up more genders accordingly. For instance, in Ingush most nouns of B gender have D in the plural, but a few have B, and two genders – B:D and B:B – can be set up.
- 6 Campbell (1997b) suggests that 3 of 28 *n-m* tokens – about 10 percent – in the sample of Nichols and Peterson (1996) have been acquired by borrowing and spontaneous change (selection from internally generated variation). This rate is much too high; at such a rate, *n-m* pronoun systems would be frequent worldwide. In fact they are virtually non-existent outside the Pacific Rim population, and the difference between frequencies inside and outside the population is statistically significant. This shows that the pronoun system has spread by inheritance and direct contact, not random generation.
- 7 On "founder effects" of such colonizing populations, see this volume's introduction, section 1.2.3.5.

Part III

Phonological Change

This page intentionally left blank

6 The Phonological Basis of Sound Change

PAUL KIPARSKY

Tout est psychologique dans la linguistique, y compris ce qui est mécanique et matériel.

F. de Saussure 1910/1911

[. . .] The Neogrammarians portrayed sound change as an exceptionless, phonetically conditioned process rooted in the mechanism of speech production.¹ This doctrine has been criticized in two mutually incompatible ways. From one side, it has been branded a mere terminological stipulation without empirical consequences, on the grounds that apparent exceptions can always be arbitrarily assigned to the categories of analogy or borrowing.² More often though, the Neogrammarian doctrine has been considered false on empirical grounds. The former criticism is not hard to answer (Kiparsky 1988), but the second is backed by a formidable body of evidence. Here I will try to formulate an account of sound change making use of ideas from lexical phonology, which accounts for this evidence in a way that is consistent with the Neogrammarian position, if not exactly in its original formulation, then at least in its spirit.

The existence of an important class of exceptionless sound changes grounded in natural articulatory processes is not in doubt, of course. It is the claim that it is the *only* kind of sound change that is under question, and the evidence that tells against is primarily of two types. The first is that phonological processes sometimes spread through the lexicon of a language from a core environment by generalization along one or more phonological parameters, often lexical item by lexical item. Although the final outcome of such *lexical diffusion* is in principle

[By permission of the author and the publisher, this chapter, originally published in John Goldsmith (ed.) *Handbook of Phonological Theory* (Blackwell, 1995), is reprinted here with minor changes; the author felt that this piece constituted as definitive a statement of his views on sound change as there could be, so that reprinting it here was deemed appropriate by all concerned.]

indistinguishable from that of Neogrammarian sound change, in mid-course it presents a very different picture. Moreover, when interrupted, reversed, or competing with other changes, even its outcome can be different.

Against the implicit assumptions of much of the recent literature, but in harmony with older works such as Schuchardt (1885) and Parodi (1923: 56), I will argue that lexical diffusion is not an exceptional type of sound change, nor a new, fourth type of linguistic change, but a well-behaved type of analogical change. Specifically, *lexical diffusion is the analogical generalization of lexical phonological rules*. In the early articles by Wang and his collaborators, it was seen as a process of phonemic redistribution spreading randomly through the vocabulary (Chen and Wang 1975; Cheng and Wang 1977). Subsequent studies of lexical diffusion have supported a more constrained view of the process. They have typically shown a systematic pattern of generalization from a categorical or near-categorical core through extension to new phonological contexts, which are then implemented in the vocabulary on a word-by-word basis. In section 1 I argue that lexical diffusion is driven by the rules of the lexical phonology, and that the mechanism is analogical in just the sense in which, for example, the regularization of *kine* to *cows* is analogical. In fact, the instances of "lexical diffusion" which Wang and his collaborators originally cited in support of their theory include at least one uncontroversial instance of analogical change, namely, the spread of retracted accent in deverbal nouns of the type *tórmènt* (from *tormént*). In most cases, of course, the analogical character of the change is less obvious because the analogy is non-proportional and implements distributional phonological regularities rather than morphological alternations. For example, the item-by-item and dialectally varying accent retraction in non-derived nouns like *mustache*, *garage*, *massage*, *cocaine* is an instance of non-proportional analogy, in the sense that it extends a regular stress pattern of English to new lexical items. What I contend is that genuine instances of "lexical diffusion" (those which are not due to other mechanisms such as dialect mixture) are *all* the result of analogical change. To work out this idea I will invoke some tools from recent phonological theory. In particular, radical underspecification and structure-building rules as postulated in lexical phonology will turn out to be an essential part of the story.

The second major challenge to the Neogrammarian hypothesis is subtler, less often addressed, but more far-reaching in its consequences. It is the question how the putatively autonomous, mechanical nature of sound change can be reconciled with the systematicity of synchronic phonological structure. At the very origins of structural phonology lies the following puzzle: if sound changes originate through gradual articulatory shifts which operate blindly without regard for the linguistic system, as the Neogrammarians claimed, why don't their combined effects over millennia yield enormous phonological inventories, which resist any coherent analysis? Moreover, why does no sound change ever operate in such a way as to subvert phonological principles, such as implicational universals and constraints on phonological systems? For example, every known language has obstruent stops in its phonological inventory, at least some unmarked ones such as *p*, *t*, *k*. If sound change were truly blind, then the

operation of context-free spirantization processes such as Grimm's law to languages with minimal stop inventories should result in phonological systems which lack those stops, but such systems are unattested.

With every elaboration of phonological theory, these difficulties with the Neogrammarian doctrine become more acute. Structural investigations of historical phonology have compounded the problems. At least since Jakobson (1929), evidence has been accumulating that *sound change itself*, even the exceptionless kind, is structure-dependent in an essential way. Sequences of changes can conspire over long periods, for example to establish and maintain patterns of syllable structure, and to regulate the distribution of features over certain domains. In addition to such top-down effects, recent studies of the typology of natural processes have revealed pervasive structural conditioning of a type hitherto overlooked. In particular, notions like underspecification, and the abstract status of feature specifications as distinctive, redundant, or default, are as important in historical phonology as they are synchronically. The Neogrammarian reduction of sound change to articulatory shifts in speech production conflicts with the apparent structure-dependence of the very processes whose exceptionlessness it is designed to explain.

A solution to this contradiction can be found within a two-stage theory of sound change according to which the phonetic variation inherent in speech, which is blind in the Neogrammarian sense, is selectively integrated into the linguistic system and passed on to successive generations of speakers through language acquisition (Kiparsky 1988). This model makes sound change simultaneously mechanical on one level (vindicating a version of the Neogrammarian position), yet structure-dependent on another (vindicating Jakobson). The seemingly incompatible properties of sound change follow from its dual nature.

My paper is organized as follows. In the next section I present my argument that lexical diffusion is analogical and that its properties can be explained on the basis of underspecification in the framework of lexical phonology. I then spell out an account of sound change which reconciles exceptionlessness with structure-dependence (section 2). Finally in section 3 I examine assimilatory sound changes and vowel shifts from this point of view, arguing that they too combine structure-dependence with exceptionlessness in ways which support the proposed model of sound change, as well as constituting additional diachronic evidence for radical underspecification in phonological representations.

1 Lexical Diffusion

1.1 "It walks like analogy, it talks like analogy..."

If lexical diffusion is not sound change, could it be treated as a subtype of one of the other two basic categories of change? Clearly it is quite unlike lexical *borrowing*: it requires no contact with another language or dialect (i.e., it is not reducible to "dialect mixture"), it follows a systemic direction set by the

Table [6].1

	Sound change	Borrowing	Lexical analogy	Lexical diffusion
Generality	Across the board	Item by item	Context by context, item by item	Context by context, item by item
Gradience	Gradient	Quantal	Quantal	Quantal
Origin	Endogenous	Contact	Endogenous	Endogenous
Rate	Rapid	Rapid	Slow	Slow
Effect on:				
Rule system	New rules	No change	Rules generalized	Rules generalized
Sound/phoneme inventory	New inventory	Peripheral	No change	No change
Vocabulary	No change	New words	No change	No change

language's own phonological system (it is a species of "drift"), and it involves a change in the pronunciation of existing words rather than the introduction of new ones.

On the other hand, it does behave like lexical *analogy* in every respect, as summarized in [table 6.1].³

It seems to be the case that lexical diffusion always involves neutralization rules, or equivalently that lexical diffusion is structure preserving (Kiparsky 1980: 412). This has been taken as evidence for locating lexical diffusion in the lexical component of the phonology (Kiparsky 1988). Being a redistribution of phonemes among lexical items, it cannot produce any new sounds or alter the system of phonological contrasts. Its non-gradient character follows from this assumption as well, since lexical rules must operate with discrete categorical specifications of features.

An important clue to the identity of the process is its driftlike spread through the lexicon, by which it extends a phonological process context by context, and within each new context item by item. This is of course exactly the behavior we find in many analogical changes. An example of such lexical diffusion is the shortening of English /ū/, which was extended from its core environment (1a), where it was categorical, by relaxing its context both on the left and on the right (Dickerson 1975). In its extended environments it applies in a lexically idiosyncratic manner. The essential pattern is as follows:

- (1) a. [-anterior] ____ $\begin{bmatrix} \text{---anterior} \\ \text{---coronal} \end{bmatrix}$
 cook, hook, shook, rook, brook, crook, hookah (short)

- b. _____ $\begin{bmatrix} \text{[-anterior]} \\ \text{[-coronal]} \end{bmatrix}$
 took, book, nook look, forsook, Wookie (short)
 snook, snooker, stook, boogie, Sook, gadzooks, spook (variable)
 bazooka (long)
- c. [-anterior] _____
 good, could, should, hood 'covering,' hoodwink (short)
 roof, rooster, hoodlum, cooper, hoof, room, root, hoodlum, hood
 'ruffian,' coop, proof (variable)
 brood, shoot, hoot, behoove, scoop, coon, coot, roost, groove . . . (long)

We can provide a theoretical home for such a mechanism of change if we adopt lexical phonology and combine it with a conception of analogical change as an optimization process which eliminates idiosyncratic complexity from the system – in effect, as grammar simplification.⁴ The mechanism that drives such redistribution of phonemes in the lexicon is the system of structure-building rules in the lexical phonology. The direction of the phonemic replacement is determined by the rule, and its actuation is triggered jointly by the generalization of the rule to new contexts, and by the item-by-item simplification of lexical representations in each context. When idiosyncratic feature specifications are eliminated from lexical entries, the features automatically default to the values assigned by the rule system, just as when the special form *kine* is lost from the lexicon the plural of *cow* automatically defaults to *cows*. The fact that in the lexical diffusion case there is no morphological proportion for the analogy need not cause concern, for we must recognize many other kinds of non-proportional analogy anyway.

To spell this out, we will need to look at how unspecified lexical representations combine with structure-building rules to account for distributional regularities in the lexicon. This is the topic of the next section.

1.2 *The idea behind underspecification*

The idea of underspecification is a corollary of the Jakobsonian view of distinctive features as the real ultimate components of speech. All versions of autosegmental phonology adopt it in the form of an assumption that a feature can only be associated with a specific class of segments designated as permissible bearers of it (P-bearing elements), and that such segments may be lexically unassociated with P and acquire an association to P in the course of the phonological derivation. But in phonological discussions the term “underspecification” has come to be associated with two further claims, mostly associated with lexical phonology, namely that the class of P-bearing segments may be extended in the course of derivation, and that lexical (underlying) representations are minimally specified.

How minimal is minimal? There are several alternative versions of underspecification on the market which differ in their answers to this question.⁵ The

most conservative position, *restricted underspecification*, is simply that redundant features are lexically unspecified. On this view, the feature of voicing in English would be specified for obstruents, where it is contrastive, but not for sonorants, which are redundantly voiced. An entirely non-distinctive feature, such as aspiration in English, would not be specified in lexical representation at all.

Radical underspecification (the version which I will assume later on) carries the asymmetry of feature specifications one step further, by allowing only one value to be specified underlyingly in any given context in lexical representations, namely, the negation of the value assigned in that context by the system of lexical rules. A feature is only specified in a lexical entry if that is necessary to defeat a rule which would assign the "wrong" value to it. The default values of a feature are assigned to segments not specified for it at a stage in the derivation which may vary language-specifically within certain bounds.

A third position, departing even further from *SPE*, and currently under exploration in several quarters, holds that the unmarked value is never introduced, so that features are in effect one-valued (privative).

Contrastive and radical underspecification both posit *redundancy rules* such as:

(2) [+sonorant] → [+voiced]

Radical underspecifications in addition posit *default rules*, minimally a context-free rule for each feature which assigns the unmarked value to it:

(3) [] → [-voiced]

The following chart summarizes the theoretical options, and exemplifies them with the values of the feature [voiced] which they respectively stipulate for voiceless obstruents, voiced obstruents, and sonorants, at the initial and final levels of representation:

		/p/	/b/	/r/	
(4)	None (full specification)	Lexical: fully specified	–	+	+
		Phonetic: fully specified	–	+	+
	Contrastive	Lexical: contrastive values	–	+	+
		Phonetic: fully specified	–	+	+
	Radical	Lexical: minimal specifications		+	
		Phonetic: fully specified	–	+	+
	Privative	Lexical: only marked values		+	
		Phonetic: only marked values		+	

As (4) shows, fully specified representations and privative representations are homogeneous throughout the phonology. Contrastive underspecification and radical underspecification both make available *two representations*, by allowing an underlying minimal structure to be augmented in the course of the derivation.

Radical underspecification moreover assumes that default values are assigned by the entire system of structure-building lexical rules. For example, in a language with a lexical rule of intervocalic voicing such as (5),⁶ the lexical marking of obstruents in intervocalic position would be the reverse of what it is in other positions, with voiced consonants unmarked and voiceless ones carrying the feature specification [-voiced] to block the rule:

(5) [] → [+voiced] / V ___ V

At what point are default values and redundant values to be assigned? I will here assume that default feature values are filled in before the first rule that mentions a specific value of that feature.⁷ Many assimilation rules do not mention a specific feature value, but simply spread the feature itself, or a class node under which that feature is lodged. Such rules can apply before the assignment of default values, yielding the characteristic pattern “assimilate, else default.”

To summarize:

- (6) a. For each feature F, a universal default rule of the form [] → [αF] applies in every language.
- b. In each environment E in underlying representations, a feature must be either specified as [αF] or unspecified, where E is defined by the most specific applicable rule R, and R assigns [-αF].
- c. Default feature values are filled in before the first rule that mentions a specific value of that feature.

(6a) guarantees that the basic choice of unmarked value of a feature is fixed language-independently, but leaves open the possibility that particular rules (universal as well as language-specific) may supersede it in special contexts. (6b) says essentially that the lexicon is minimally redundant: feature specifications are only allowed where needed to defeat rules. Subject to (6c), default feature values can be assigned either cyclically, at the word level, or post-lexically. Redundant values are normally assigned post-lexically.

An early argument for radical underspecification was that it makes it possible to extend the first level of phonological rules to account for the structure of morphemes (Kiparsky 1982), eliminating from the theory the extremely problematic “Morpheme Structure Constraints (MSC),” never satisfactorily formalized, and heir to a multitude of embarrassing problems and paradoxes. The structure of morphemes in a language can now be treated simply as derivative of the rules and conditions on its earliest level of phonological representations.⁸

The distinction between structure-changing and structure-building (feature-filling) operations is important here. Feature-changing assimilations (i.e., those which override existing feature specifications) have been shown to consist of two independent processes, delinking of the features of the target, followed by spread of a feature to it (Poser 1982; Cho 1990). The introduction of structure-building rules, which make essential use of radical underspecification, has several striking consequences. It has provided the basis for new accounts of “strict cycle” effects (Kiparsky 1993) and of inalterability (Inkelas and Cho 1993). If these prove to be correct, they will provide the strongest kind of support for underspecification. My contention here is that it is also implicated in the explanation of lexical diffusion. In the next section, we will see how this works.

1.3 Lexical diffusion as analogy

Equipped with this theory of lexical rules and representations, let us go back to the \bar{u} -shortening process (1) to illustrate the general idea. $[\bar{u}]$ and $[\bar{u}]$ are in the kind of semi-regular distribution that typically sets off lexical diffusion processes. The core context (1a) has almost only $[\bar{u}]$ to this day. Exceptions seem to occur only in affective or facetious words of recent vintage: *googol* (-plex), *googly*, *kook*. And the context most distant from the core, not included in any of the extensions of (1a), has overwhelmingly long $[\bar{u}]$: *doom*, *stoop*, *boom*, *poop*, *boob*, *snood*, *loose*, *Moomin*, *loom*, *baboon*, *spoof*, *snooze*, *snoot*, *snoop*, etc. Even here some subregularities can be detected. There are a few shortened $[\bar{u}]$'s before coronals even if the onset is coronal or labial (*foot*, *stood*, *toots(ie)*, *soot* versus *booth*, *moon*, *pool*, *tool*, *loose*, *spoon*, *food*, *mood*, *moose* . . . with long $[\bar{u}]$). Before labials, however, the exclusion of short $[\bar{u}]$ is near-categorical.⁹

Let us suppose that the core regularity is reflected in the lexical phonology of English by a rule which assigns a single mora or vocalic slot to stressed /u/ between certain consonants, and two moras or vocalic slots elsewhere, provided that syllable structure allows. Suppose the original context of this rule was [-anterior] ____ [-anterior, -coronal]. As a structure-building rule it can, however, be extended to apply in the contexts (1b) and (1c). This part of the change is a natural generalization (simplification) of the rule's environment, in principle no different from the extension of a morphological element to some new context. But because structure-building rules are defeasible by lexical information, such an extension of the shortening rule need not effect any overt change at first: the extended rule simply applies (in the synchronic grammar) to the words which always had short $[\bar{u}]$ in that context, now reanalyzed as quantitatively unmarked, while words with long $[\bar{u}]$ in those contexts are now prespecified with two moras in the lexicon to escape the effect of the generalized shortening rule. But once the rule's context is so extended, words can fall under its scope, slowly and one at a time, simply by being “regularized” through loss of the prespecified length in their underlying representations. This is the lexical diffusion part of the process.

The model for this phase of the analogical regularization is the existence of a systematic context (the core shortening environment) where length is systematically predictable, which is extended on a case-by-case basis. The normal scenario of lexical diffusion, then, is contextual rule generalization with attendant markedness reversal and subsequent item-by-item simplification of the lexicon. In principal, it could proceed until the rule is extended to all contexts and all quantitative marking is lost in the lexicon. In this example, however, the robust exclusion of short [ǔ] in the context between labials sets a barrier to further extension of the rule to those contexts. The result is the pattern of partial complementation that we find in the modern English distribution of [ǔ] and [ū].

Let us now turn to the rule which thanks to Labov's work has become the most famous case of lexical diffusion: the "æ-Tensing" of Philadelphia and several other Eastern US dialects, applying in the core environment before tautosyllabic *-f, -s, -θ, -n, -m*.

First, I would like to raise a terminological point, relating to a larger issue of fact which is tricky but luckily does not have to be settled here. Although usually referred to as æ-Tensing, æ-Lengthening would be a more appropriate term because the vowel is not always tense. Phonetically, it is typically a lax long [ɛ̃] in the dialects I am concerned here with (see, e.g., Bailey 1985: 174). Phonologically, that may be a better analysis as well, because it is the same vowel as the word-finally lengthened lax [ɛ̃] in the truncated form of *yes* ("yeah"). At least in the feature system that I will be using in section 3.2 below, this is a genuine [-Tense] vowel. But since it won't make much of a difference for present purposes, I'll just follow tradition and continue to talk of "Tensing," while writing the "tensed" vowel non-committally as *A*.

What is the status of [æ] and [A] in these dialects? Are the two phonemically distinct? Is their distribution governed by rule? It is clear that they are two distinct phonemes, in the sense that there is an irreducible lexical contrast between them in certain environments. From the viewpoint of many phonological theories, that settles the second question as well: they contrast and they do not alternate with each other, so their distribution cannot be rule-governed.

The distribution of [æ] and [A] is, however, far from random. In the framework proposed in Kiparsky (1982), the regularities that govern it have a place in the lexical module of the grammar as structure-building lexical rules which assign the appropriate default specifications of tenseness to the underlying unspecified low front vowel, which we can write /a/. The lexicon need specify only those comparatively few instances of lax /æ/ which fall out of line. This analysis follows from the requirement (6b) that the redundancy of the lexicon must be reduced to a minimum.

The Philadelphia version of æ-Tensing (Ferguson 1975; Kiparsky 1988; Labov 1981, 1994) includes all the core environments *-f, -s, -θ, -n, -m* as well as the extension *-d, -l*, as discussed further below:

(7) *Philadelphia lexical æ-Tensing rule:*

æ → A before tautosyllabic *f, s, θ, m, n, (d, l)*

In New York, the rule applies also more generally before voiced stops and before ʃ :

(8) *New York lexical æ-Tensing rule:*

$\text{æ} \rightarrow \text{A}$ before tautosyllabic $f, s, \theta, \text{ʃ}, m, n, b, d, \text{ʝ}, g$

In accord with our previous discussion, (7) and (8) are structure-building rules which assign [+Tense] to a in regular words like (9a). The value [-Tense] is then assigned by default to a in regular words like (9b). The only cases of lexically specified Tenseness are exceptional words with [-Tense] in Tensing environments, such as (9c):

- (9) a. pAss, pAth, hAm, mAn
 b. mat, cap, passive, panic
 c. alas, wrath

In fact, the unpredictable cases for which lexical specification of $[\pm\text{Tense}]$ is required are probably even fewer than is apparent at first blush. Consider the contrast before consonant clusters in polysyllables illustrated by the words in (10):

- (10) a. astronaut, African, plastic, master (lax æ OK)
 b. After, Afterwards, Ambush, Athlete¹⁰ (Tense A)

These data follow directly from rule (7) on standard assumptions about English syllable structure. English syllabification tends to maximize onsets, and *str-*, *fr-* are possible onsets, but *ft-*, *mb-*, *θl-* are not, so the relevant VC sequence has to be tautosyllabic in (10b) but tends to be heterosyllabic in (10a). Independent evidence for this syllabification is the fact that vowel reduction, restricted to unstressed open syllables, is possible before permitted onsets, as in *astronomy*, but not before other clusters, as in *athletic* (Kahn 1976).¹¹

Rule (7) must apply at level 1 in the lexical phonology of English. Five arguments for this position were given in Kiparsky (1988). We can now add two more. First, the observations in the preceding paragraph show that (7) must precede the “left capture” rule that attaches onset consonants to a preceding stressed syllable (perhaps making them ambisyllabic). But left capture can be shown to apply at level 1 (as well as at later levels), so æ -Tensing must apply at level 1 as well. The evidence that left capture applies at level 1 is the pattern of shortening seen in derived words such as (11):

- (11) a. cȳcle cȳclīc cȳclīcīty
 b. trībe trībal trībalīty

Myers (1987) has shown that the various English shortening processes, including “Trisyllabic Shortening” and the shortening before *-ic* as in *cȳcle* ~ *cȳclīc*, are special cases of a general lexical rule which shortens nuclei in closed syllables,

including those which become closed through the application of “left capture” resyllabification. But the short initial syllable of *cyclicality* is clearly inherited from *cyclic*, since the conditions for shortening no longer hold in the derivative *cyclicality* (cf. *tribality*). It follows that the shortening must be cyclic. Therefore, the left capture rule that feeds shortening, as well as the *æ*-Tensing rule (7) that itself precedes left capture, must also be cyclic. But cyclic phonology is located at level 1.

My second new argument for the level 1 status of *æ*-Tensing is that it explains the variation in the past tenses of strong verbs such as *ran*, *swam*, *began*. These /*æ*-vowels are regularly lax in Philadelphia, a fact accounted for by ordering *æ*-Tensing before the *æ* → A ablaut rule which introduces /*æ*/ in the past tense. Since ablaut is a level 1 rule, *æ*-Tensing, which precedes it, must also apply at level 1. The possibility of applying the rules in reverse order, still within level 1, predicts a dialect in which the vowels of these verb forms do undergo *æ*-Tensing. Such a dialect is in fact attested in New York, as Labov notes. In contrast, non-major category words such as *am*, *had*, *can* and the interjections *wham!*, *bam!* have lax *æ* in all dialects where *æ*-Tensing is lexical. The lack of variation in these cases is likewise predicted because non-lexical categories are not subject to the rules of lexical phonology.

With these synchronic preliminaries out of the way, let us turn to the rule’s lexical diffusion. Labov shows that [+Tense] vowels have replaced (or are in the process of replacing) [–Tense] vowels in a class of words in Philadelphia, especially in the speech of children and adolescents. The innovating class of words includes: (i) words in which *æ* is in the proper consonantal environment of the tensing rule (7) but, contrary to what the core rule requires, in an open syllable, such as (12a), and (ii) words in which *æ* is before *l* and *d*, voiced consonants not included among the rule’s original triggers.¹² In cases like (12c), both extensions of the rule are combined:

- (12) a. plAnet, dAmage, mAnage, flAnnel
 b. mAd, bAd, glAd, pAl
 c. personAlity, Alley, Allegheny

There are several facts that need explaining about these developments. First, the environments into which tense *A* is being extended are not arbitrary phonologically. There is no “lexical diffusion” of *A* before voiceless stops, the class of consonants that is systematically excluded from the core tensing environment as well as from the Philadelphia and New York versions of the rule. Second, there are no reported cases of lax *æ* being extended into words which have regular tense *A* in accord with (7), for example, in words like *man*, *ham*, *pass*. Third, [æ] changes not to any old vowel, but precisely to [A], the very vowel with which it is in partial complementation by (7).

If we assume that lexical diffusion is nothing more than the substitution of one phoneme for another in the lexical representations of words, we have no explanation either for the direction of the change, or for the envelope of

phonological conditions that continues to control it. Such a theory cannot distinguish the Philadelphia development from a wholly random redistribution of tense and lax *a*, nor even explain why it should involve this particular pair of vowels at all.

If we recognize that the distribution of tense and lax *a* in Philadelphia is an analogical extension of rule (7), then we are in a position to explain these facts. The phonological conditions under which tense *A* spreads through the lexicon are an extension of the rule's original context in two respects: (i) the condition requiring the triggering consonant to be tautosyllabic is dropped (here one might also explore the possibility that the tensing rule gets reordered after left capture), and (ii) *l*, *d* are included among the conditioning consonants. This development conforms to the pattern of contextual generalization with item-by-item implementation of the extended environment that is typical of lexical diffusion. The scenario is similar to the one sketched out above for the shortening of /ū/. The old tensing rule, applicable before a class of tautosyllabic consonants, is generalized by some speakers to apply before certain additional consonants and the tautosyllabicity condition is dropped. Speakers who have internalized the rule in this generalized form can pronounce tense *A* in words of the type (12). But being structure-building (feature-filling), the rule applies only to vowels underspecified for the feature of tenseness, and speakers with the generalized rule can still get lax *æ* in the new contexts by specifying the vowels in question as la[x] in their lexical representation. In the resulting variation in the speech community, the generalized rule, and the forms reflecting the unmarked lexical representations, will enjoy a selective advantage which causes them gradually to gain ground.

I conclude that *æ*-Tensing supports the claim that lexical diffusion is the analogical extension of structure-building lexical rules. We see that, on the right assumptions about the organization of phonology and about analogical change, lexical diffusion fits snugly into the Neogrammarian triad, and all its by now familiar properties are accounted for. A wider moral that might be drawn from this result is that even "static" distributional regularities in the lexicon, often neglected in favor of productive alternations, can play a role both in synchronic phonology and in analogical change.

1.4 What features are subject to diffusion?

According to the present proposal, the prerequisite for lexical diffusion is a context-sensitive structure-building lexical rule and its starting-point is an existing site of neutralization or partial neutralization of the relevant feature in lexical representations. The original environment of the *æ*-Tensing rule (originally the "broad *a*" rule) was before tautosyllabic *f*, *s*, *θ*, *-nt*, *-ns*, as in *pass*, *path*, *laugh*, *aunt*, *dance*. It became generalized to apply before the nasals *n*, *m* in all the Mid-Atlantic dialects, and later before voiced stops as well (see (7) and (8)). The cause of this generalization of the lexical *æ*-Tensing rule is probably the

merger with a *post-lexical* raising/tensing rule in those dialects where their outputs coincided (Kiparsky 1971, 1988). In those dialects which either lacked the lexical rule entirely (as in the Northern Cities), or retained it as a different rule (as in Boston, where broad *a* was pronounced as [a]), the post-lexical *æ*-Tensing rule can today be observed as a separate process in several variant forms. In the Northern Cities, it yields a continuum of tensing and raising, with most tensing before nasals and least tensing before voiceless stops.

(13) *Tensing environments in Northern Cities dialects:*

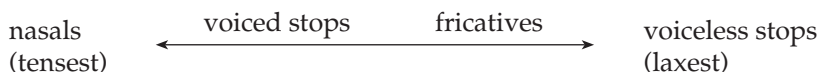

In Boston, only the environment at the top of the scale, the nasals, triggers tensing and raising; before other consonants, the dialect retains lax *æ* (Labov 1994).

The merger of the inherited lexical *æ*-Tensing rule with these two types of post-lexical *æ*-Tensing gives the Philadelphia and New York versions of lexical *æ*-Tensing, respectively. Specifically, by adding the environments of the original lexical *æ*-Tensing rule (*-f, -s, -θ, -ns, -nt*) and the environments of the post-lexical *æ*-Tensing/Raising of the Boston type (nasals), we get exactly the environments of the core Philadelphia rule (7). And by adding the environments of the original lexical *æ*-Tensing rule and the most active environments of the post-lexical *æ*-Tensing/Raising of the Northern Cities type (13) (nasals, voiced stops, and fricatives), we get very nearly the New York rule (8). Only the failure of *-ŋ* to trigger *æ*-Tensing in New York remains unexplained.¹³

Having acquired lexical status in this way, Tensing then spreads to new lexical items, that is, it undergoes lexical diffusion. Thus, the lexical diffusion of *æ*-Tensing in the Mid-Atlantic dialects is due to its lexical status in those dialects, inherited from the lexical "broad *a*" rule of British English.

Labov (1981, 1994) makes the interesting suggestion that lexical diffusion is an intrinsic characteristic of some kinds of phonological features and Neogrammarian sound change is characteristic of others. Lexical diffusion affects "higher order classes," phonological features such as tenseness and length, which are defined in terms of several unrelated phonetic properties, such as duration, height, peripheralness, and diphthongization. Features like front/back and high/low, on the other hand, will not undergo lexical diffusion because their physical realization is more direct. If lexical diffusion really does depend on whether a feature is realized on a single physical dimension or on several, my account of lexical diffusion as the analogical extension of structure-building lexical rules would have to be given up at least in its present form.

One problem with Labov's idea is that *æ*-Lengthening, though it involves the same feature in all dialects, undergoes lexical diffusion in the Mid-Atlantic dialects and not in the Northern Cities. In response to that objection, Labov suggests that the rule operates at a "high level of abstraction" in the Mid-Atlantic dialects and at a "low level of abstraction" in the Northern Cities. But this amounts to using the term "abstraction" in two different senses. On the one

hand, it is a phonetic property having to do with the degree of diversity and complexity of the feature's phonetic correlates. With respect to æ-Tensing, however, it has to be understood in a functional/structural sense, as something like the distinction between phonemic and allophonic status, or lexical and post-lexical status – for that seems to be the one relevant distinction between the Mid-Atlantic and the Northern Cities versions of æ-Tensing. But there is no reason to believe that these two kinds of “abstraction” can be identified with each other. Certainly features differ in the intrinsic complexity and diversity of their phonetic realizations: stress and tenseness probably tend to have relatively complex and diverse phonetic effects, whereas fronting, lip rounding, height, and voicing probably tend to have more uniform phonetic effects. But this would appear to be true whether they are distinctive or redundant. I know of no evidence to show that the intrinsic complexity and diversity of the phonetic reflexes of a feature is correlated with its lexical/phonemic status, let alone that these two kinds of “abstractness” are the same thing.

The interpretation of lexical diffusion that I have advocated here would entail that the structural notion of abstractness is all we need, and the phonetic character of the feature should be immaterial. The generalization that only lexically distinctive features can undergo lexical diffusion, itself a rigorous consequence of LPM [Lexical Phonology and Morphology] principles, predicts exactly the observed difference between the Mid-Atlantic dialects and the other US dialects. The contrast between them shows that the same feature, assigned by one and the same rule in fact, can be subject to lexical diffusion in one dialect and not in another, depending only on whether it is lexically distinctive or redundant. In addition, it also correctly predicts the existence of lexical diffusion in such features as height and voicing, which on Labov's proposal should not be subject to it.¹⁴

2 The Structure-Dependence of Sound Change

2.1 *Sound change is not blind*

The majority of structuralists, European as well as American, thought they could account for phonological structure even while conceding to the Neogrammarians that sound changes are “blind” phonetic processes. In their view, the reason languages have orderly phonological systems is that learners impose them on the phonetic data, by grouping sounds into classes and arranging them into a system of relational oppositions, and by formulating distributional regularities and patterns of alternation between them. The reason languages have phonological systems of only certain kinds would then have to be that learners are able to impose just such systems on bodies of phonetic data. But, on their scheme of things, fairly simple all-purpose acquisition procedures were assumed to underlie the organization and typology of phonological inventories, and the combinatorial regularities apprehended by learners.

It seems clear, however, that a battery of blind sound changes operating on a language should eventually produce systems whose phonemicization by the standard procedures would violate every phonological universal in the book. The linguist who most clearly saw that there is a problem here was Jakobson (1929). Emphasizing that phonological structure cannot simply be an organization imposed *ex post facto* on the results of blind sound change, he categorically rejected the Neogrammarian doctrine in favor of a structure-governed conception modeled on the theory of orthogenesis (or nomogenesis) in evolutionary biology (a theory now thoroughly discredited, but for which Jakobson always maintained a sneaking fondness). His basic thesis is that sound changes have an inherent direction (“elles vont selon des directions déterminées”) toward certain structural targets.¹⁵

Jakobson was in fact able to cite fairly convincing long-term tendencies in the phonological evolution of Slavic, involving the establishment of proto-Slavic CV syllable structure by a variety of processes (degemination, cluster simplification, metathesis, prothesis of consonants, coalescence of C + y, coalescence of V + nasal), and the rise of palatal harmony in the syllable domain through a series of reciprocal assimilations. Since it is human to read patterns into random events, it would be prudent to look at such arguments with a measure of suspicion. But the number and diversity of phonological processes collaborating to one end do make Jakobson's case persuasive. Others have since argued for similar conclusions. For example, Riad (1992), working in the framework of prosodic generative phonology, has analyzed the major sound changes in North Germanic over the past two millennia as so many stepwise resolutions of an inherent conflict between fixed accent, free quantity, and bimoraic foot structure.

Jakobson further argued that sound change respects principles of universal grammar, including *implicational universals*. The point is quite simple. How could an implicational relation between two phonological properties A and B have any universal validity if sound changes, operating blindly, were capable of changing the phonetic substrates of A and B independently of each other?

Moreover, Jakobson's implicational universals were crucially formulated in terms of *distinctive* features. But purely phonetically conditioned sound changes should not care about what is distinctive in the language (distinctiveness being, by the structuralists' assumptions, a purely structural property imposed *a posteriori* on the phonetic substance). So what prevents sound change from applying in such a way as to produce phonological systems that violate universals couched in terms of the notion of distinctiveness?

For some reason, Jakobson's work is rarely taken notice of in the literature on sound change, and I am not aware of any explicit attempts to refute it. Perhaps it has simply been rejected out of hand on the grounds that it begs the question by invoking a mysterious mechanism of orthogenesis which itself has no explanation, and that in addition, it throws away the only explanation we have for the regularity and exceptionlessness which are undeniably characteristics of a major class of sound changes. Nevertheless, the existence of sound changes that respect structure and are derived by it in certain ways seems well

supported. How can we account for the coexisting properties of exceptionlessness and structure-dependence?

I believe that Jakobson was on the right track in looking to evolutionary biology as a paradigm for historical linguistics. We just need to reject the disreputable version of evolutionary theory that he claimed to be inspired by and replace it by the modern view of variation and selection. In the domain of sound change, the analog to natural selection is the inherently selective process of transmission that incorporates them into the linguistic system. Thus sound change is both mechanical in the Neogrammarian sense, and at the same time structure-dependent, though not exactly in the way Jakobson thought.

We are now free to assume that variation at the level of speech-production is conditioned purely by phonetic factors, independently of the language's phonological structure, and to use this property to derive the exceptionlessness property, just as the Neogrammarians and structuralists did. The essential move is to assign a more active role to the transmission process, which allows it to intervene as a selectional mechanism in language change. Traditionally, the acquisition of phonology was thought of simply as a process of organizing the primary data of the ambient language according to some general set of principles (for example, in the case of the structuralists, by segmenting it and grouping the segments into classes by contrast and complementation, and in the case of generative grammar, by projecting the optimal grammar consistent with it on the basis of Universal Grammar). On our view, the learner in addition selectively intervenes in the data, favoring those variants which best conform to the language's system. Variants which contravene language-specific structural principles will be hard to learn, and so will have less of a chance of being incorporated into the system. Even "impossible" innovations can be admitted into the pool of phonetic variation; they will simply never make it into anyone's grammar.

The combined action of variation and selection solves another neglected problem of historical phonology. The textbook story on phonologization is that redundant features become phonemic when their conditioning environment is lost through sound change. This process (so-called secondary split) is undoubtedly an important mechanism through which new phonological oppositions enter a language. But the textbooks draw a discreet veil over the other cases, surely at least equally common, where – in what may seem to be exactly analogous situations – the redundant feature simply disappears when its triggering environment is lost.

The two types of outcome are not just distributed at random. The key generalization seems to be that phonologization will result more readily if the feature is of a type which already exists in the language. We could call this the *priming effect* and provisionally formulate it as follows:

- (14) Redundant features are likely to be phonologized if the language's phonological representations have a class node to host them.

This priming effect, a diachronic manifestation of structure-preservation, is documented for several types of sound change, tonogenesis being perhaps the

most interesting case. The merger of voiced and voiceless consonants normally leaves a tone/register distinction *only in languages which already possess a tone system* (Svantesson 1989). There is one special circumstance under which non-tonal languages can acquire tone by loss of a voicing contrast: in certain Mon-Khmer languages, according to Svantesson, "strong areal pressure to conform to the phonological pattern of those monosyllabic tone languages that dominate the area" (ibid.). It seems, then, that when the voicing that induces redundant pitch is suppressed, the pitch will normally be phonologized only if the language, or another language with which its speakers are in contact, already has a tonal node to host it. On the Neogrammarian/structuralist understanding, the priming effect remains mysterious. On our variation/selection model, such top-down effects are exactly what is expected.

Analogous priming effects can be observed in such changes as compensatory lengthening and assimilation. De Chene and Anderson (1979) find that loss of a consonant only causes compensatory vowel lengthening when there is a pre-existing length contrast in the language. So the scenario is that languages first acquire contrastive length through other means (typically by vowel coalescence); then only do they augment their inventory of long vowels by compensatory lengthening.¹⁶ Yet loss with compensatory lengthening is a quintessentially regular, Neogrammarian type of sound change (in recent work analyzed as the deletion of features associated with a slot with concomitant spread of features from a neighboring segment into the vacated slot). Similarly, total assimilation of consonant clusters resulting in geminates seem to happen primarily (perhaps only?) in languages that already have geminates (Finnish, Ancient Greek, Latin, Italian). Languages with no pre-existing geminates prefer to simplify clusters by just dropping one of the consonants (English, German, French, Modern Greek). In sum, we find a conjunction of exceptionlessness and structure-sensitivity in sound change which does not sit well with the Neogrammarian/structuralist scheme. The two-level variation/selection model of change proposed is in a position to make much better sense of it.

The two-level scheme can be related to certain proposals by phonemic theorists. It has often been argued that redundant features help to perceptually identify the distinctive features on which they structurally depend.¹⁷ Korhonen (1969: 333–5) suggests that only certain allophones, which he calls *quasi-phonemes*, have such a functional role, and that it is just these which become phonemicized when the conditioning context is lost. This amounts to a two-stage model of secondary split which (at least implicitly) recognizes the problem we have just addressed: in the first stage, some redundant features become quasi-distinctive, and in the second stage, quasi-distinctive features become distinctive when their conditioning is lost. If the conditions which trigger the first stage were specified in a way that is equivalent to (14), this proposal would be similar to the one put forward above. Korhonen's suggestion is, however, based on the direction of allophonic conditioning: according to him, it is allophones which precede their conditioning environment (and only they?) which become quasi-phonemicized. This is perceptually implausible, and does

not agree with what is known about secondary split, including tonogenesis. Ebeling (1960) and Zinder (1979) propose entities equivalent to Korhonen's quasi-phonemes in order to account for cases where allophones spread to new contexts by morphological analogy. They do not spell out the conditions under which allophones acquire this putative quasi-distinctive status either. However, the cases they discuss fit in very well with the priming effect, since they involve features which are already distinctive in some segments of the language and redundant in others becoming distinctive in the latter as well.

2.2 *The life cycle of phonological rules*

Early generative work on historical phonology thought of sound change as rule addition. One of the most interesting consequences of this idea was that sound changes should be capable of non-phonetic conditioning, through the addition of morphologically conditioned rules, and through the addition of rules in places other than the end of the grammar ("rule insertion"). But of course not just any sort of non-phonetic conditioning is possible. It turned out that the only good cases of rule insertion involved the addition of rules before automatic (transparent) rules, often of a phonetic character, so that an interpretation along the lines of the above structure-preservation story seems more likely. Moreover, this approach by itself does not explain one of the most basic facts about sound change, its phonetic naturalness. Nor, in the final analysis, does it address the question of the relationship between universals and change in a principled way.

By articulating the phonological component into a set of modules with different properties, lexical phonology allows us to think of sound change in a more constrained way that is still consistent with the selection/variation model (Kiparsky 1988). Sound change can be assumed to originate through synchronic variation in the production, perception, and acquisition of language, from where it is internalized by language learners as part of their phonological system. The changes enter the system as language-specific phonetic implementation rules, which are inherently gradient and may give rise to new segments or combinations of segments. These phonetic implementation rules may in turn become reinterpreted as phonological rules, either post-lexical or lexical, as the constraints of the theory require, at which point the appropriate structural conditions are imposed on them by the principles governing that module. In the phonologized stages of their life cycle, rules tend to rise in the hierarchy of levels, with level 1 as their final resting place (Zec 1993).

In addition to articulatory variation, speech is subject to variation that originates in perception and acquisition, driven by the possibility of alternative parsing of the speech output (Ohala 1986, 1989). Sound changes that originate in this fashion clearly need not be gradient, but can proceed in abrupt discrete steps. Moreover, like all reinterpretation processes, they should be subject to inherent top-down constraints defined by the linguistic system: the "wrong" parses that

generate them should spring from a plausible phonological analysis. Therefore, context-sensitive reinterpretations would be expected not to introduce new segments into the system, and context-free reinterpretations (such as British Celtic $k^{w} \rightarrow p$) would be expected not to introduce new features into the system; and neither should introduce exceptional phonotactic combinations.

Dissimilation provides perhaps the most convincing confirmation of this prediction. That dissimilatory sound changes have special properties of theoretical interest for the debate on levels of phonological representation was first pointed out by Schane (1971). Schane marshaled evidence in support of the claim that "if a feature is contrastive in some environments but not in others, that feature is lost when there is no contrast," and argued on this basis for reality of phonemic representations. Manaster Ramer (1988) convincingly showed that the contrastiveness of the environment is not a factor in such cases, and rejected Schane's argument for the phoneme entirely. However, all his examples, as well as Schane's, conform to a kindred generalization which still speaks for the role of distinctiveness in sound change: *only features which are contrastive in the language are subject to dissimilation*. But in this form, the generalization is a corollary of what we have already said. The reasoning goes as follows. Dissimilation is not a natural articulatory process. Therefore, it must arise by means of perceptual reanalysis. But the reanalyzed form should be a well-formed structure of the language, hence in particular one representable in terms of its authentic phonological inventory.

The other properties of dissimilation, that it is quantal rather than gradual, and that it is often sporadic, can be derived in the same way. They likewise hold for the other so-called minor sound changes, such as metathesis. Not that minor sound changes are *necessarily* sporadic. On the contrary, they will be regular when the phonotactic constraints of the language so dictate. Dissimilation is regular where it serves to implement constraints such as Grassmann's law, and the same is true of metathesis (Hock 1985; Ultan 1978): for example, the Slavic liquid metathesis is part of the phonological apparatus that implements the above-mentioned syllable structure constraints.

The respective properties of major and minor sound changes are summarized in (15):

(15)	Major changes	Minor changes
Source in speech:	Production	Perception and acquisition
Parameter of change:	Articulatory similarity	Acoustic similarity
Gradiency:	Gradient	Discrete
Effect on system:	New segments and combinations	Structure-preserving
Regularity:	Exceptionless	Can be sporadic

Conditions on sound change can then be seen as categorical reinterpretations of the variable constraints that determine the way optional rules apply. Because of the formal constraints on possible structural conditions, obligatory rules cannot fully replicate the complex pattern of preferences generated in language use at the optional stage. Consequently, when a rule becomes obligatory, its spectrum of contextual conditions is simplified and polarized. Thus, this view of sound change explains both why structural conditions on phonological rules retain a gross form of naturalness, and why they nevertheless do not show the intricate micro-conditioning observed at the level of phonetic implementation.

Not only are phonological conditions on rules derived from phonetic conditions motivated by perception and production, but also the nature of conditions involving morphology, style, and even sex and class can be explained in the same way. For example, some languages of India have undergone sound changes restricted to the speech of lower castes. Such changes are a categorical reflection, under conditions where social boundaries are sharply drawn, of the generally more advanced nature of vernacular speech, due to the fact that the elite tends to stigmatize and inhibit linguistic innovations for ideological reasons (Kroch 1978).

Our conclusion so far is that the Neogrammarians were right in regarding sound change as a process endogenous to language, and their exceptionlessness hypothesis is correct for changes that originate as phonetic implementation rules. They were wrong, however, in believing that sound change *per se*, as a mechanism of change, is structure-blind and random. The process also involves an integration of speech variants into the grammar, at which point system-conforming speech variants have a selective advantage which causes them to be preferentially adopted. In this way, the language's internal structure can channel its own evolution, giving rise to long-term tendencies of sound change.

3 Naturalness in Sound Change

The study of natural phonology offers a further argument for the structure-dependence of even Neogrammarian-type exceptionless sound change, and thereby for the selection/variation view of sound change. In this section, I support this claim by showing the role that underspecification plays in the explanation of natural assimilation rules and vowel shifts – not only of the synchronic rules, but equally, and perhaps in greater measure, of the historical processes that they reflect.

3.1 *The typology of assimilation*

Autosegmental phonology allows assimilation to be treated as the spread of a feature or feature complex from an adjacent position. Coupled with assumptions

about underspecification, feature geometry, and the locality of phonological processes, it yields a rich set of predictions about possible assimilation rules. Cho (1990) has developed a parametric theory of assimilation based on these assumptions. The following discussion draws heavily on her work, which, though formulated as a contribution to synchronic phonology, bears directly on sound change as well.

If feature-changing processes consist of feature deletion plus feature filling, we can say that assimilation is fed by weakening rules which de-specify segments for the feature in question, to which the feature can then spread by assimilation from a neighboring segment. The feature-deletion (neutralization) process which on this theory feeds apparent feature-changing assimilation can be independently detected by the default value it produces wherever there is no assimilation (complementarity between assimilation and neutralization).

If we assume that assimilation is spreading of a feature or class node, then it immediately follows that there should be no assimilations which spread only the unmarked value of a feature, since there is no stage in the derivation where only unmarked values are present in the representation. For example, there are two-way assimilations of [\pm voiced], as in Russian, and one-way assimilations of [+voiced], as in Ukrainian and Santee Dakota, but no one-way assimilations which spread only [-voiced]. Cho's survey confirms this striking prediction for a substantial sample of languages:¹⁸

- (16) a. Russian: /tak+že/ → ta[g]že 'also,'
 /bez tebjə/ → be[s] tebjə 'without you'
 b. Ukrainian: /jak že/ → ja[g]že 'how,'
 /bez tebe/ → be[z] tebe 'without you'

One-way assimilation (spread of the marked feature value) as in (16b) results from ordering assimilation after the assignment of default feature values. Since two-way assimilation applies when default feature specifications have already been assigned, it must involve feature deletion at the target as a prior step, followed by spread to the vacated site. This yields the following additional predictions.

First, two-way assimilation should apply preferentially in environments where neutralization is favored. This seems to be correct: for example, the prevalence of feature neutralization in coda position explains the prevalence of assimilation in coda position (e.g., regressive assimilation in consonant clusters).

Second, in environments where neutralization applies but where no trigger of assimilation is present (e.g., in absolute final position), two-way assimilation should be associated with neutralization in favor of the unmarked (default) value. This prediction is also confirmed by such typical associations as (two-way) voicing assimilation with final devoicing, or place assimilation with coda neutralization of place.¹⁹

Suppose we also allow assimilation to be ordered either before or after *redundant* values are assigned. This gives two subtypes of two-way assimilation: one in which only distinctive feature specifications (e.g., [\pm voiced] on obstruents) trigger assimilation, the other where redundant feature specifications also trigger assimilation. For voicing assimilation, the first type is represented by Warsaw Polish (as well as Russian and Serbo-Croatian), the second by Cracow Polish:

- (17) a. Warsaw Polish: ja[k] nigdy 'as never'
 b. Cracow Polish: ja[g] nigdy 'as never'

The theory predicts that one-way assimilation cannot be triggered by redundant feature values (i.e., it must be of the Warsaw type, not of the Cracow type). In fact, the voicing assimilation rules of Ukrainian and Santee (e.g., (16b)) are triggered by obstruents only. It also follows that if a language has both Warsaw-type and Cracow-type assimilation, then the former must be in an earlier level. For example, Sanskrit has lexical voicing assimilation triggered by obstruents and post-lexical voicing assimilation by all voiced segments. For similar reasons, if a language has both one-way and two-way assimilation, then the former must be in an earlier level.

In combination with the formal theory of phonological rules, underspecification provides the basis for Cho's parameterized typology of assimilation. According to this theory, every assimilation process can be characterized by specifying a small number of properties in a universal schematism:

- i site of spreading (single feature or a class node);
- ii specification of target and/or trigger;
- iii locality (nature of structural adjacency between trigger and target);
- iv relative order between spreading and default assignment;
- v directionality of spreading;
- vi domain of spreading.

This approach has a number of additional consequences of interest for both synchronic and historical phonology.

Since codas are the most common target of weakening, and adjacency the most common setting of the locality parameter, it follows that regressive assimilation from onsets to preceding codas will be the most common type of assimilation. Thus, no special substantive principle giving priority to regressive assimilation is required.

Additional consequences follow if we bring in feature geometry. Since the domain of spreading can be limited to a specific node in the feature hierarchy, it follows that assimilation between segments belonging to the same natural class is a natural process. The traditional generalization that assimilation is favored between segments which are already most similar in their feature composition (Hutcheson 1973; Lee 1975) is thus explained in a principled way.

“Strength hierarchies” (proposed, e.g., by Foley 1977 to account for the direction of assimilation) also turn out to be epiphenomenal.

An element may be ineligible to spread either because it already bears an incompatible feature specification (whether as an inherent lexical property or assigned by some rule), or because some constraint blocks it from being associated with the spreading feature value. Once the spread of a feature has been so interrupted, further spread is barred by locality. Thus, “opaque” elements need not themselves be specified for the spreading feature; they must only bear the relevant class node.²⁰

It seems clear from the work of Cho and others that underspecification is not only relevant for the synchronic analysis of lexical phonology, but plays a role in defining the conditioning of phonetic processes. The difference between marked, default, and redundant feature values – a basically structural difference – constitutes a major parameter along which assimilatory processes vary. We must conclude that a large and well-studied class of sound changes is *simultaneously* exceptionless and structure-dependent.

3.2 Vowel shifts

The point of this section is similar to that of the last, though this one is offered in a more speculative vein. I argue that vowel shifts are another type of natural sound change whose explanation, on closer inspection, depends on the *structural* status of the triggering feature in the system, specifically on whether the feature is specified in the language’s phonological representations or is active only at the phonetic level.

Vowel shifts fall into a few limited types. The most important generalizations about the direction of vowel shifts is that tense (or “peripheral”) vowels tend to be raised, lax (non-peripheral) vowels tend to fall, and back vowels tend to be fronted (Labov 1994). How can we explain these canonical types of vowel shifts, and the direction of strengthening processes in general? The attempt to answer this question will reveal another kind of top-down effect.

One of the puzzling questions about vowel shifts is their “perseverance” (Stockwell 1978). What accounts for their persistent recurrence in languages such as English, and their rarity in others such as Japanese?²¹ A simple argument shows that tenseness-triggered raising and laxness-triggered lowering occur only in languages which have both tense and lax vowels in their inventories at some phonological level of representation. Otherwise, we would expect languages with persistent across-the-board lowering of all vowels (if they are lax) or persistent across-the-board raising of all vowels (if they are tense). But there do not seem to be any such languages.

But why would the shift-inducing force of the feature [±Tense] depend on the existence of both feature specifications in the language’s vowels? A reasonable hypothesis would be that vowel shifts are the result of a tendency to maximize perceptual distinctness. Consider first the idea that vowel shifts are

the result of the enhancement of contrastive features, in this case, tenseness. This hypothesis is undermined by several facts. First, vowel shifts often cause mergers, both through raising of tense vowels (as in English *beet* and *beat*) and through lowering of lax vowels (as in Romance). If the motivation is the maximization of distinctness, why does this happen? Second, even when vowel shifts do not cause mergers, they often simply produce “musical chairs” effects, chain shifts of vowels which do nothing to enhance their distinctness (for example, the Great Vowel Shift). Third, tenseness does not by any means have to be distinctive in order to trigger vowel shifts. In English, for example, tenseness has been mostly a predictable concomitant of the basic quantitative opposition of free and checked vowels, and at some stages it has been entirely that. Yet tenseness is the feature that seems to have triggered the various phases of the Great Vowel Shift. Moreover, those vowels for which tenseness did have a distinctive function do not seem to have shifted any more than the ones for which it did not.

The alternative hypothesis which I would like to explore here is that tenseness can trigger vowel shift if it is present in the language’s phonological representations – not necessarily underlyingly, but at any phonological level where it can feed the phonological rules that assign default values for the height features. Vowel shifts can then be considered as the result of suppressing marked specifications of the relevant height feature in lexical representations, resulting in the assignment of the appropriate default value of the feature in question to the vacated segment by the mechanisms discussed above. For example, loss of the feature specification [–High] from a tense vowel will automatically entail its raising by default. The reason why tenseness and laxness activate vowel shifts only if they are both present in the language’s phonological representations would then be that, as the theory predicts, only those feature values which are specified in phonological representations can feed default rules, and a feature that plays no role whatever in a language’s phonology will not figure in its phonological representations, but will be assigned at a purely phonetic level if at all. This would mean that an abstract distinction at yet another level, that between phonetic and phonological tenseness/laxness, would also be critical to sound change.²²

Let us see how this approach might work for the Great Vowel Shift. Assume, fairly uncontroversially, that height is assigned by the following universal default rules:²³

- (18) a. [–Tense] → [–High]
 b. [] → [+High]
 c. [] → [–Low]

In a language where tenseness plays no role, (18a) is not active, and default height is assigned only by the “elsewhere” case (18b). The canonical three-height vowel system is represented as follows:

(19)	Distinctive value	Default values (assigned by (18b))
High vowels (i, u)	[]	[+High, -Low]
Mid vowels (e, o)	[-High]	[-Low]
Low vowels (æ, ɔ)	[+Low]	

To augment the system with the feature [\pm Tense], I'll assume the classification of vowels motivated in Kiparsky (1974):²⁴

(20)		-Back		+Back	
		-Round	-Round	-Round	+Round
+Hi, -Low	+Tense	i	ɯ	u	
	-Tense	ɪ	ɨ	ʊ	
-Hi, -Low	+Tense	e	ɤ	o	
	-Tense	ɛ	ʌ	ɔ ₁	
-Hi, +Low	+Tense	æ	ɐ	ɔ ₂	
	-Tense	a	ɑ	ɒ	

Tenseness itself is related to length by the following default rules:

- (21) a. VV → [+Tense]
 b. V → [-Tense]

Now we are ready to lay out the vowel system of late Middle English (ME) (c.1400). At this stage, all front vowels were unrounded and all back vowels were rounded. So ME *ā*, *a* were low non-tense *front* vowels, like the [a] of Boston *car*, *father* and of French *patte* (Dobson 1968: 545, 594). The distinction between free and checked nuclei appears to have been basically quantitative (long versus short). Tenseness was distinctive, however, in the long mid vowels (*beet* versus *beat*, *boot* versus *boat*). I will assume that *all other vowels were non-tense*. The vowel specifications were accordingly as follows (default and redundant features parenthesized):

		-Back, (-Round) Long Short		+Back, (+Round) Long Short	
(+Hi, -Low)	(-Tense)	ī bite	ɪ bit	ū bout	u but
-Hi, (-Low)	+Tense (-Tense)	ē beet ē beat	ɛ bet	ō boot ō boat	ɔ pot
+Low	(-Tense)	ā bate	a bat		

The default values for the features High and Low are assigned by (18). Tense-ness plays no role in the assignment of vowel height. Only the default rule (21b) is active, assigning the feature specification [-Tense] to vowels not lexically marked as [+Tense].

Tenseness was neutralized in short vowels; hence [ɛ] represents both shortened [ē] (*kēp:kĕpt, mēt:mĕt*), and shortened [ē] (*drēm:drĕmt, lēp:lĕpt, clēn:clĕnliness*), and [ɔ] represents both shortened [ō] (*lose:lost, shoot:shot*) and shortened [ō] (*clothes:cloth, nose:nozzle, prōtest:prōtestation*).

The ME diphthongs were:²⁵

(23)	ay	bait	aw	law
	ɔy	boy	ɔw	blow
			ɛw	dew
	uy	buoy	ɪw	pew

According to the analysis of the historical records by Dobson (1968), the vowel shift took place in three stages, from our perspective consisting of two height shifts with an intervening tensing process:

(24)	Middle English	Raising (≈ 1500)	Tensing (≈ 1650)	Raising (18th c.)
	ī	ei		
	ū	ou		
	ē	ī		
	ō	ū		
	ē		ē	ī
	ō		ō	
	ā		ǣ	ē
	a		æ	

First shift: raising. In the first stage of the vowel shift, which Dobson dates to the fifteenth century, [ē] and [ō] (the only tense vowels of the system according to our assumption) were raised (unmarking of [-High] and default assignment of [+High] by (18b)), and [ī] and [ū] were diphthongized (activation of (18a)).

Second shift: tensing. The next phase of the Great Vowel Shift (seventeenth century) was a general tensing of the long vowels: [ē] was tensed to [ē̄], [ɔ̄] was tensed to [ō̄], and long and short [a] were tensed to [ǣ]:²⁶

(25)		-Back, Long	(-Round) Short	+Back, Long	(+Round) Short
(+Hi, -Low)	(+Tense) (-Tense)	ī beet	i bit	ū boot	u but
-Hi, (-Low)	(+Tense) (-Tense)	ē beet	ɛ bet	ō boat	ɔ pot
(-Hi), +Low	(+Tense)	ā̄ bate	ǣ bat		

The tensing process can again be seen as an activation of a default rule, in this case (21a). We have now arrived at a system of long and short vowels (25) where *tenseness is entirely predictable*. Yet tenseness in this system feeds the next, third stage of vowel shift, which again raises tense vowels.

Third shift: raising with merger. The second raising of tense vowels (eighteenth century) again implements the default rule (18), which assigns height on the basis of tenseness. But this raising was more restricted, applying only to the long tense front vowels: [ē̄] was raised to [ī̄] (loss of [-High]), and [ā̄] was raised to [ē̄] (loss of [+Low]). This stage of raising differed from the first in that the resulting vowels merged with existing nuclei (the reflexes of ME /e/ and /ai/, respectively). Moreover, not all dialects underwent this change, and words such as *great, steak, break* retaining the older mid vowel in the standard language are probably from those dialects.

To sum up: the Great Vowel Shift is triggered by both distinctive and non-distinctive tenseness. Evidently it is not the distinctiveness of the feature but its phonological (as opposed to phonetic) status that counts. This supports the idea adopted in lexical phonology that the assignment of phonological default features can take place at several levels of the derivation, including in particular post-lexical phonology.

4 Conclusion

I have defended the Neogrammarian hypothesis that sound change is exceptionless and subject only to phonetic conditioning against two potentially serious objections. The first objection, based on lexical diffusion, is answered by the analysis of the phenomenon as a species of non-proportional analogical change proposed and motivated in section 1. The second objection is based on top-

down effects in sound change. Structural work in historical phonology in the Jakobsonian tradition supports the position that phonological organization plays a role in sound change, in particular through diachronic “conspiracies” implementing canonical syllable structure. In section 2, I discussed two other types of structure-dependency in sound change: priming effects in secondary split, and maintenance of universal constraints on phonological systems (e.g., the stability of implicational universals, and the failure of cascades of secondary splits to produce giant phonemic systems). Finally, in section 3, I discussed the role in sound change of the status of features as distinctive versus redundant, and phonological versus phonetic, drawing in part on the parametric rule typologies emerging from recent work on natural phonological processes, which make use of abstract properties of phonological representations to explain generalizations in domains where purely physical explanations have hitherto dominated. I argued that all four types of top-down effects can be reconciled with exceptionlessness by giving the transmission process an active selectional role in language change.

NOTES

- 1 This paper is in part the result of an exchange with Andrew Garrett and of a reading of portions of Labov (1994) in draft form, though neither Garrett nor Labov necessarily agrees with me, or with the other. I am also grateful to them both as well as to the other participants of a workshop on sound change at Stanford University in February 1993 for valuable comments on a draft of this paper.
- 2 Such a move is of course legitimate insofar as the exceptions can be identified in some principled way, as when “minor sound changes” such as dissimilation and metathesis are systematically set aside as being of perceptual origin.
- 3 I exclude here from sound change the “minor” sound changes discussed below in section 2.2. Also, the “no-change” entries in the last line abstract away from *lexical split*, which can result from sound change by the mechanisms discussed at the end of section 2.2 (e.g., *ass/arse*), by analogy (*staff/stave*), and, I would expect, from lexical diffusion as well.
- 4 However, no commitment to any particular formal evaluation measure need be made at this level. Virtually any theory which characterizes analogy as structural optimization ought to be able to get the same results.
- 5 See Steriade (1987), Archangeli (1988), and Mohanan (1991) for general surveys from varying points of view. For simplicity of presentation, I will illustrate the point here with segmental features. But everything I say holds equally for other phonological information such as syllabic structure and stress (Kiparsky 1993).
- 6 This is not how such a rule would actually look. I give it in this old-fashioned form just for simplicity’s sake.
- 7 For two other formulations, see Kiparsky (1982, 1985) and Archangeli (1984), Archangeli and Pulleyblank (1989). The

- position put forward here is in a sense intermediate between those two.
- 8 The elimination of MSCs invalidates the objection to underspecification by Christdas (1988), Clements (1985), Mohanan (1991), and others based on the claim that that Morpheme Structure Constraints must be able to refer to default values. The objection is in any case internally incoherent because many of the MSCs cited by these authors require reference to syllable structure assigned by phonological rules, so they couldn't possibly apply to underlying forms. All that these examples show is that level 1 phonological rules in some languages require reference to both feature values. But radical underspecification predicts exactly that because it says that default values can be assigned cyclically, a possibility independently motivated by the cyclic interaction of default and spread rules in harmony systems.
- 9 The affective words *oops*, *whoopee*, and *shutup* are the only exceptions I am aware of.
- 10 Labov (1993) records one token of lax æ in *athlete*; this could be the result of lexicalization of the trisyllabic pronunciation with anaptyctic ə .
- 11 Another apparently idiosyncratic contrast is reported by Labov in hypocoristic names, where *Frannie*, *Danny*, *Sammy* normally have tense A and *Cassie*, *Cathy* normally have lax æ . This could be accounted for on the assumption that the former are analyzed, by speakers who have this contrast, as derived from monosyllabic bases (*Fran*, *Dan*, *Sam*), to which the rule applies regularly on the first cycle, whereas the latter are treated as unanalyzed. So even these seemingly unpredictable cases may well turn out to be rule-governed.
- 12 For the three -d words in (12b), the tensing is now obligatory for Philadelphia speakers of all ages.
- 13 On the other hand, this derivation of the New York pattern would also explain the relatively high rate of tensing/raising before ʃ compared to other fricatives in New York, by the relatively high rate of postlexical tensing/raising before ʃ compared to other fricatives in the Northern Cities (Kiparsky 1971).
- 14 For example, Wanner and Cravens (1980) argue for the lexical diffusion of an intervocalic voicing rule in the Tuscan dialect of Italian.
- 15 As early as 1886, Kruszewski [(1887: 146)] had cited Darwin on "directed evolution" in order to explain why sound changes, though originating in random articulatory fluctuations, progress in specific directions ("sich in bestimmter Richtung auf der erwähnten Linie fortbewegen [d]").
- 16 The only contrary case I know of, where compensatory lengthening is reported to have created distinctive length, is Occitan (Morin 1992).
- 17 Jakobson et al. (1952: 8) note that redundant features may under certain conditions even substitute for the conditioning distinctive features.
- 18 If the devoicing in $\text{/bit+z/} \rightarrow \text{[bits]}$ were a genuine case of assimilation, it would refute the theory. In fact, it appears to reflect a phonetically based constraint (as far as is known, valid in all languages) which restricts voicing to a continuous portion of the syllable that includes the nucleus (Cho 1990).
- 19 Place neutralization yields coronals. For example, "For Fante, the pattern of nasal plus consonant may be stated as involving homorganicity with the predominant articulation if any, or otherwise [n]" (Welmers 1973: 65). A similar pattern of nasal place neutralization to [-n] (with or

- without concomitant assimilation) is found in Finnish, Greek, and Italian, and reportedly in Croatian dialects, Avar and Lakk. With debuccalization, the result is a placeless nasal (Sanskrit *anusvāra*), see [...] Paradis and Prunet (1991); apparent neutralization to [ŋ] is via coronal or placeless nasals.
- 20 The argument of Steriade (1987) that contrastive underspecification is to be preferred over radical underspecification is based entirely on the following important generalization about transparency: a feature spreads only through segments for which the feature in question is redundant, never through segments for which it is distinctive and which have the default value of the feature. But this follows from the assumption that all segments for which a feature is distinctive bear a class node for that feature, together with normal locality considerations. So, contrary to what Steriade implies, her generalization is fully consistent with radical underspecification.
- 21 It is true that the Okinawan dialect has undergone a kind of vowel shift (M. Matsuda, pers. comm.). However, this was apparently a raising of the *short* vowels *e*, *o* to *i*, *u*, their long counterparts remaining unaffected. So on my assumptions, tenseness cannot have been the triggering factor of this change. Rather, I assume that it is a vowel reduction phenomenon, consisting of the neutralization of the distinctive feature [-High], with the neutralized vowels assigned default [+High] by rule (18b) below.
- 22 The same issue arises in the case of the feature of nasality. According to Schourup (1973) and Ruhlen (1978), whether nasal vowels are raised or lowered depends on whether nasalization is distinctive in the language or not. However, it is not impossible that the relevant distinction is really whether nasalization figures in the language's phonological representations or not.
- 23 I assume that default rules operate in gradient fashion at the level of phonetic implementation, in this case accounting for the general tendency for lax vowels to be articulated lower than tense vowels.
- 24 I have left out the front rounded vowels in this version of the chart because they play no role in the English data discussed here.
- 25 The diphthong [ɥy] (*buoy, boil, oil*) merged with [ɔy] (*boy, choice, noise*) in most dialects in the ME period. The other old diphthongs were eliminated as part of the vowel shift as follows. ME [ay] merged with ME [ā] and [ɛw] with [ɪw] about 1650, earlier in Northern and Eastern dialects (Dobson 1968: 594, 778, 798). The diphthong [aw] (*law*) was monophthongized to [ɔ̄] in the seventeenth century (p. 786), and [ɔw] (*blow*) was monophthongized to [ɔ̄], merging with the vowel of *boat* c.1600 (p. 805).
- 26 I am here departing from Dobson's chronology by assuming that long and short [a] were tensed at the same time along with the other long vowels. Dobson (1968: 594) thinks that long [ā] was tensed earlier than short [a] was, as early as the fifteenth century, which would make this part of tensing part of the first shift. Adopting his account would make the first shift more complex but not alter my main point that vowel shift is an unmarking of vowels with concomitant assignment of default values to the vacated features. Since the orthoepic evidence does not seem altogether clear on this point, I have assumed that the tensing processes were concurrent, which gives the simpler schema in (24).

7 Neogrammarian Sound Change

MARK HALE

The essential claim of the Neogrammarians regarding “sound change” was simply that it was *systematic* (“konsequent”). Hermann Paul, in explicating what this label meant, states the following (Paul 1880: 69, given here in translation):

When we speak of systematic effect of sound laws we can only mean that given the same sound change within the same dialect every individual case in which the same phonetic conditions are present will be handled the same. Therefore either wherever earlier the same sound stood, also in the later stages the same sound is found or, where a split into different sounds has taken place, then a specific cause – a cause of a purely phonetic nature like the effects of surrounding sounds, accent, syllabic position, etc. – should be provided to account for why in the one case this sound, in the other that one has come into being.¹

This passage contains the two assertions which are assumed in modern literature on change to be the hallmark of Neogrammarianism: sound change² is *regular* and *purely phonetically conditioned*. As the insightful work of Hoenigswald (1978) has shown, these claims are true, within the context of the work of the Neogrammarians themselves, by definition. Ancillary hypotheses (e.g., “analogy,” the phrase “within the same dialect,” and the concept of “sporadic sound change”³) allow the Neogrammarians to restrict the use of the term “sound change” to precisely those events which are regular and phonetically conditioned.

The question naturally arises, for the modern linguist armed with a vastly different conception of the nature of the object of linguistic study (“the grammar”), of whether or not the terminological distinction made by the Neogrammarians can be given a more substantive foundation – that is, whether the distinction between “sound change” and “sporadic sound change” can be made to follow from our current conception of the human linguistic endowment and the nature of language change. In this chapter, I will argue that the Neogrammarians were correct in distinguishing between two fundamentally different types of event which can occur in the transmission of human language.

Whether or not regular sound change is “purely phonetically conditioned” also turns out to involve a number of definitional matters which will also be addressed in what follows.

1 Diachronic Modularity and “Change”

Perhaps controversially, I will adopt a view of “change” which I believe allows one to keep distinct the various factors which give rise to the historical record of a given language.⁴ I will distinguish between change proper and the diffusion of that change.⁵ While the sociolinguistic diffusion of a change is generally necessary if that change is to become part of the historical record of a given language, it seems clear that our responsibility to account for change cannot be coherently taken as being limited to those changes which in fact happen to diffuse. The factors which give rise to a different representation or rule in the phonological system of an acquirer – given by a properly constructed learning algorithm – are not, in my view, the same as those factors which regulate the diffusion of that new representation or rule within a community of speakers (given, presumably, by a properly constructed sociolinguistic theory). Questions arising from the Neogrammarian hypothesis – particularly the “regularity” and “conditioning” issues – are about *possible* changes, not about any individual existing change. It is impossible, *a priori*, to ascertain whether a given *possible* innovation will diffuse, since, being merely a potential event, it has no particular sociolinguistic context.⁶ To put the case more strongly, I believe that a full evaluation of the Neogrammarian hypothesis allows one to place each potential change in any imaginable sociolinguistic context, including those from which diffusion is virtually inevitable.⁷

The historical record of an actual linguistic tradition involves, therefore, several filtering subsystems (“modules”), as reflected in figure 7.1. I believe that it is critical to keep these various subsystems and their internal dynamics distinct from one another, if progress is to be made in understanding the contribution made by each to the overall linguistic record.⁸

Developing a coherent model of the first box is the central responsibility of historical linguistics. The “diffusion” box represents the primary domain for sociolinguistic theorizing. The final box includes, among other issues, such matters as who had access to writing (and who did not), what linguistic features the writing system encodes (perhaps indirectly), and how these features can be extracted from the extant record, what survives, etc. Much of this is the central subject matter of the field of “philology.” A comprehensive understanding of the actual historical record thus requires contributions from all of these fields (constrained by relevant synchronic theories of the linguistic modules involved – phonological, morphological, syntactic, etc.). The Neogrammarian hypothesis is, in my view, a claim about the first box – the set of possible change events – and *only* the first box.

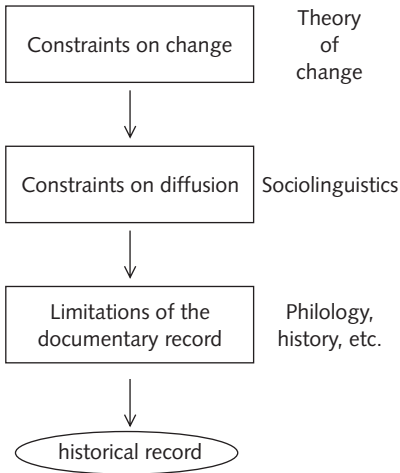

Figure 7.1 Modularity and the historical record

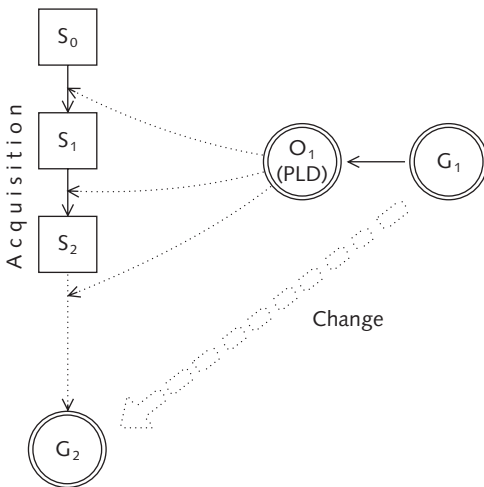

Figure 7.2 The nature of change

It is critically important to provide a precise characterization of what precisely a “change event” is. Consistent with the “modular” approach discussed above, we believe that “change” is to be conceived of as the set of differences between the grammar generating the primary linguistic data (PLD) used by an acquirer and the grammar ultimately constructed by that acquirer.⁹ Idealizing away from the problem of “multiple sources” we can sketch the relevant scenario as in figure 7.2 (for discussion of earlier, similar diagrams, see Janda 2001).¹⁰

In this figure O_1 represents the acquirer's source – the PLD which are themselves the output of an existing grammar G_1 ; S_0 is the initial state of the acquirer's knowledge (in L1 acquisition – and arguably in L2 acquisition as well – this is Universal Grammar (UG)). The intermediate, transitory stages of the acquisition process are represented by S_1 , S_2 , etc. The end-point of the acquisition process, for this particular grammar, is represented by G_2 : evidence which the acquirer receives after this point which is not consistent with G_2 will not be used to “modify” this knowledge state (though it may give rise to a new acquisition sequence, of course). “Change,” in the sense we will be using it in this chapter, is simply the differences between G_1 and G_2 . Note that since G_2 comes into existence at some well-defined point in the acquisition process, all “change” under this model will necessarily be abrupt.¹¹

2 Regularity and Phonetic Conditioning

In general, modern literature on the Neogrammarian doctrine assumes that its two central propositions – that sound change is *regular* and that it is *purely phonetically conditioned* – are independent. The propositions are thus usually evaluated in a manner consistent with that assumption. It has been claimed by numerous modern authors that *both* propositions are false (see, e.g., Kiparsky 1995b, reprinted this volume (but hereafter simply “1995”), with literature).

It is not without interest to attempt to understand *why* the two proposals are linked by the Neogrammarians themselves. I believe that the Neogrammarian hypothesis represents not two independent conjoined claims about the nature of sound change, but rather two necessarily related components of a single conception of the phenomenon. I will demonstrate this first by showing that a standard interpretation of the meaning of “regular” appears to be, on its own, relatively uninteresting. However, when put together with the issues surrounding the proper characterization of the *environment* in which a change takes place – that is, its conditioning – the issues become much more intriguing. While the Neogrammarians cannot, given the state of their understanding of the nature of grammars, have had precisely the system I propose in mind, it seems that the fundamental success of methods which are directly dependent upon Neogrammarian notions, such as the comparative method, indicate that their pre-theoretical phenomenological insight in this domain was quite advanced.¹²

Turning first to the “regularity” issue, it would appear that the standard interpretation of this term in historical linguistics is relatively straightforward. Given a change of the type $X \rightarrow Y/Z$, the change is regular iff for every X in environment Z in G_1 , we find Y in G_2 .¹³ It seems clear that “sound change” (and indeed, any change) will be “regular” under this conception of what precisely “regularity” is. A change will be a maximally general statement of a difference between G_1 and G_2 of figure 2. If a claimed change ($X \rightarrow Y/Z$) is a true assertion about the relationship between G_1 and G_2 , then the conditions

for the application of the term “regular” will be met. While this appears at first to make “regularity” a resoundingly uninteresting issue, I will attempt to show in what follows that it allows one to focus the discussion on precisely those issues most relevant to the understanding of the “regularity of sound change.”

Let us examine a typical case of what has traditionally been called “sporadic” sound change (generally felt to be non-regular – i.e., outside the domain of Neogrammarian “sound laws”): Proto-Polynesian (PPN) **lango* shows up as *ngaro* in Maori.¹⁴ The expected outcome, given the regular change of PPN *l* to Maori *r*, is *rango* – the attested form shows an irregular metathesis.¹⁵ This “change” took place on at least one occasion in the speech of someone from whom, for sociolinguistic reasons, it diffused.¹⁶ An accurate statement of that change at the moment of innovation will require that the environment, Z, be *lexical*, rather than phonological – that is, this was a change in the phonological representation of an individual lexical item, not in the phonological system of Maori. Since, if the statement of the change is to be accurate, the environment must fully spell out the lexical item in which the change took place, the change will be regular within its domain (in this case, a single lexical item).

We see, therefore, that the *environment* is crucially involved in any discussion of “regularity.” If the term “regular sound change” is to have any useful meaning, we cannot use it to refer to any change which is regular in its stated environment (for, if the environment is stated correctly, this will always be the case). On the other hand, we cannot require of a change that it have *no* conditioning environment if it is to be counted as “regular” – this would exclude many cases which are clearly regular in the required sense (e.g., intervocalic lenition, final consonant loss, etc.). One coherent way to limit the term “sound change” is thus by requiring that the environment in which the change takes place be specified in *phonological* rather than lexical terms. This was, in some ways, the tack taken by the Neogrammarians, and it seems a useful one.

Neogrammarian theory was thus never intended to account for changes in the phonological representations associated with individual lexical items. Such “lexical” changes are rather numerous – for example, my grandmother’s word for what I call a ‘couch’ was ‘*davenport*.’ This is not a change anyone would want to call a “sound change,” clearly, even though the phonological representation associated with a given semantic entity has changed. If we restrict “sound change,” as we, in my view, must if we are to exclude *dævnport* > *katwč*, to instances in which the environment is to be stated in phonological, rather than (e.g.) lexical terms, it is clear that sound change will be regular in the required sense.¹⁷

It thus appears that fundamentally distinct types of misanalysis are involved in the two cases. It would not be helpful to the enterprise of historical linguistics if this difference were to be ignored. To call the contrast between “(regular) sound change” and lexical changes of the type we have discussed above “merely definitional” entails that there is no crucial distinction in the underlying dynamic which gives rise to the two types of change event. To the extent that there is a

fundamental difference in these mechanisms the “regularity of sound change” ceases to be a purely terminological matter.

3 The Causes of Change

Given the notion of “change” we have adopted, the possible causes of change are highly restricted.¹⁸ A more detailed examination of the acquisition process will reveal why this is so. The components involved are illustrated (in a schematic way) in figure 7.3.

In figure 7.3, A represents the interpretation of the output of the grammar (a mental representation) by the articulatory performance system (including all relevant cognitive and physiological systems).¹⁹ In keeping with widespread assumptions, I take this mapping to be universal, though perhaps “chaotic” in the technical sense.²⁰ B represents the various transformations that the actual acoustic signal which results from a given articulatory act will undergo. These are generally contingent upon environmental factors and design properties of the organism performing the articulatory act (size of resonating cavity, force and direction of ambient airflow, etc.). Though no doubt universal, these factors are clearly “chaotic.” An essentially random subset of output of B (that portion the acquirer is in a position to hear) must then be processed by the speaker’s perceptual system – this transformation is indicated by C in figure 7.3. Again, I will assume this mapping to be universal and, arguably, chaotic. The portion of the resulting perceptual process deemed by the learning algorithm (D) to be relevant to the acquisition task will be treated as the PLD by the acquirer. The learning algorithm itself, uncontroversially, will be taken as deterministic and universal.

Processes internal to the source grammar (e.g., phonological rules and representations) are not directly accessible to the learner. One of the key questions confronting a theory of language acquisition is just what types of inference the acquirer can draw from the quite indirect evidence for these processes that is present in the PLD. Only those aspects of these processes which are reflected in some manner in the PLD can be acquired. If the mapping from the PLD to the grammar is deterministic, as I am assuming, then aspects of the source grammar unambiguously reflected in the PLD will normally imply acquisition of those features (i.e., no change along the relevant dimension).

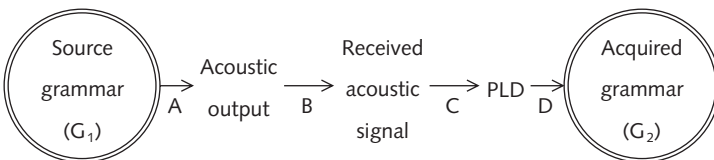

Figure 7.3 Sources for “noise” in the PLD

These considerations lead to the following conclusion: change can *only* result from the acquirer being exposed to primary linguistic data (PLD) which differs in some way from the PLD which were presented to the source during the source's own acquisition. There are two primary forces giving rise to such differences (see Hale 1998, 1997 and Ohala 1981aff for extensive discussion):

- i The unique subset of data presented to the acquirer of G_2 may, and in virtually every case will, be different from that presented to the acquirer of G_1 either in *scope* or in *sequence*, or both (cf. Janda 1990, 1994a).
- ii The acquirer may mistake the effects of the speaker's production system (A), of ambient effects on the acoustic stream (B), or of his or her own perceptual system (C) as representative of G_1 -internal representations or computations. These are the "noise"-introducing factors sketched in figure 7.3.

The factors shaping the PLD given in (ii) above are *contingent* and *sporadic* in their effects (if systematic factors of these types exist, it appears that they can be filtered out as irrelevant by the acquirer). While chance distortion introduced by any of these factors may impact the acquirer's ultimate representation of a given lexical item (and thus lead to "lexical" change of the type discussed above), they are too context-dependent to give rise to regular phonological change. Only the factors in (i) – the *finiteness* and *order of presentation* problems – should be relevant to what we have called "regular phonological change."

The "finiteness" problem is potentially relevant in the following sense: while the total output of the source grammar with respect to some phonological sequence may provide more than sufficient evidence for an unambiguous parse of that sequence, the acquirer gets only a subset of the evidence. The idea here is relatively simple: the realization of phonological targets by the source grammar speaker will look like a scatter diagram, with a mid-point in that position in the acoustic space which most unambiguously reflects the true nature of the target involved. For example, in realizing an aspirated voiceless labial stop, specific instantiations will have different temporal durations for the stop and for the aspiration, or the stop may involve more or less fully realized closure, etc. Since the acquirer gets as evidence an essentially random subset of these realizations (out of which she or he must construct a representation of the target), it is always possible that in spite of the generally clear target realizations for the source speaker (given a sufficiently large corpus of utterances), the acquirer may end up positing a different target articulation.

The "order of presentation" problem is probably relevant in that, having established some representation for a given phonological sequence (given the finite evidence available to her or him), the acquirer will be able to subsequently parse realizations of that sequence as consistent (i.e., within the margin of error) with her or his current hypothesis, even if such realizations may in general be *more consistent* with the target grammar's actual output representations. That is, having formulated a hypothesis about what a given acoustic sequence

represents (in terms of output of the grammar), the acquirer will only surrender that hypothesis if subsequent evidence lies completely outside the acceptable “margin of error” for realization of the posited representation.²¹

These two factors, taken together, provide the basic dynamic which underlies the type of diachronic misanalysis which we have called “regular” or “Neogrammarian” sound change. With this background, we will now turn to a consideration of one of the most significant recent discussions of the Neogrammarian hypothesis – that of Kiparsky (1995).

4 Kiparsky on Sound Change

In a characteristically innovative and exciting paper, Kiparsky (1995) presents a view of sound change which is sharply critical of Neogrammarian doctrine. There are three major sections to Kiparsky’s paper, which we will deal with in the order in which he presents them.

4.1 *Underspecification and phonological change*

The first part of Kiparsky’s paper proposes a type of phonological change not previously described in the literature. The basic idea is relatively straightforward. Taking English nasals as our example, it is clear that they are all voiced ([+voice]). This means of course that given the information that a segment is [+nasal], voicing is predictable (much as the plural /kæts/ is predictable from the existence of a nominal stem /kæt/ with no override of the default plural). The general principle that redundant, (i.e., predictable) information should not be stored in the lexicon (since it is derivable) can thus be invoked to deduce that nasals do not have a [+voice] specification in underlying representation. On the other hand, they clearly should not be marked [–voice], either. It thus follows that they carry no value for the feature [voice], that is, they are *underspecified* with respect to voicing.

A problem arises, however, in the course of a derivation in which, for example, stops assimilate in voicing to following consonants. In general, nasals will trigger voicing of voiceless stops in such an instance, but how can they, if the nasals do not bear the relevant [+voice] feature? Such redundant, predictable values must be “filled in” before the relevant rule applies, it seems. If this analysis is correct, there must be a process within the phonological component which fills in default values for underspecified segments.²² That is, there are rules in phonology which provide default structure at some point in the derivation for segments which lack (but require by the time of phonetic realization) values for the features in question.

One of the central ways in which underspecification can be exploited is as follows. Imagine a situation in which the bulk of the lexicon of some language

shows regular penultimate stress. Suppose further that there is a handful of lexical exceptions to this generalization. Underspecification would license an analysis in which the stresses of the lexical exceptions are specified in the lexicon, whereas the (predictable) penultimate stresses are assigned by default (i.e., when there is no lexical override).²³

As Kiparsky eloquently points out, this gives rise to a potential mechanism of change familiar from many cases of “regularizing” morphological change. Failure to acquire “exceptional” underlying specification will license the application of the default rules to the lexeme in question, giving rise to “regularization.” The difference in this case is, however, that we are not speaking of “morphological” regularization, but rather of *phonological* regularization. The distinction will be critical, as the discussion below will show.

Kiparsky cites two examples of what we might call “phonological regularization.” The first concerns the shortening of English /u:/. As Kiparsky points out, this shortening was regular (in the Neogrammarian sense) in the environment [–anterior] ____ [–anterior, –coronal].²⁴ The environment for the change was “extended” (in Kiparsky’s terms) “by relaxing its context both on the left and on the right” (section 1.1). In lexical items which show the “extended environment,” the shortening took place in a lexically idiosyncratic manner. Thus when the environment was only ____ [–anterior, –coronal], we find shortening in cases such as *took, book, nook*, etc. We find length in *bazooka*. And the outcome is “variable” in the case of *snook, snooker, boogie, Sook, gadzooks, spook*.²⁵ When the environment was “extended” to [–anterior] ____, we find shortening in *good, could, should, hood* ‘covering,’ *hoodwink*, length in *brood, shoot, hoot, behoove, scoop, coon, coot, roost, groove*, and “variation” in *roof, rooster, hoodlum, cooper, hoof, room, root, hood* ‘ruffian,’ *coop, proof*.

The second example discussed by Kiparsky is the well-known instance of *æ*-Tensing, which in the “core” case took place before tautosyllabic *f, s, θ, n*, and *m*. We simplify Kiparsky’s presentation, which is quite detailed, and discuss only the Philadelphia case, in which the rule shows, in addition to the “core” environments above, an extension to the environment before *d* and *l* (as well as occurring before the segments given in the “core” environment) and a relaxation of the tautosyllabicity requirement. Since the [+tense] feature of *æ* is “predictable” in core environments, one can assume that *æ* is underlyingly unspecified for tense and is assigned the feature [+tense] by a “structure-building” process such as the one outlined above which assigns default values to underspecified segments. The rare exceptions in core environments (Kiparsky lists *alas* and *wrath*) will have an *æ* which is exceptionally marked [–tense] in the lexicon, thus preventing the structure-building rule from assigning it the default (for this environment) [+tense] specification. Labov has shown that *æ*-Tensing in Philadelphia is being extended beyond its core environment in the two ways mentioned above. First, some *æ*’s which meet the conditioning environment as far as the following segment are concerned, but in which the consonant in question is *not* tautosyllabic with the *æ* in question, show the tensing anyway (*planet, damage, manage, flannel*). Second, the consonantal

environment for the tensing is being extended to include cases of *æ* before *l* and *d* (e.g., *mad*, *pal*). Kiparsky makes three important points about the “extension” of the tensing rule: (i) “the environments into which tense *A* is being extended are not arbitrary phonologically”; (ii) “there are no reported cases of lax *æ* being extended into words which have regular tense *A*”; and (iii) “[*æ*] changes not into any old vowel, but precisely to [A].”

Kiparsky’s analysis of the “extension” of *æ*-Tensing runs as follows (section 1.3):

The old tensing rule, applicable before a class of tautosyllabic consonants, is generalized by some speakers to apply before certain additional consonants and the tautosyllabicity condition is dropped . . . But being structure-building (feature-filling), the rule applies only to vowels underspecified for the feature of tenseness, and speakers with the generalized rule can still get lax *æ* in the new contexts by specifying the vowels in question as *la*[*x*] in their lexical representations.

Why might the rule be extended in this way? In Kiparsky’s view (section 1.1) analogical change, of which this is an example, is “an optimization process which eliminates idiosyncratic complexity from the system” – it is “grammar simplification.”

I have some difficulty seeing either of the cases discussed above as involving “optimization” or “simplification” in any meaningful sense. In the case of the shortening of /*u*:/, is it really (computationally) more optimal or simpler to change a system which requires an exceptionless “structure-building” rule which “shortens” /*u*:/ in a well-defined environment ([–anterior] ____ [–anterior, –coronal]) to one which requires a rule of /*u*:/–shortening, for example, in the environment [–anterior] ____ but requires memorization of a list of lexical exceptions? Concerning *æ*-Tensing, is the environment “before *f*, *s*, *θ*, *m*, *n*, *l*, *d*” more optimal or simpler, in any meaningful sense, than the environment “before *f*, *s*, *θ*, *m*, *n*” but not *l* and *d*?

Indeed, as mentioned above, it is not clear that notions such as “optimization” and “simplification” have any interesting role to play in diachronic linguistics. For example, suppose that it is “simpler” or “more optimal” not to maintain obstruent voicing contrasts in codas. This principle would be “phonetically grounded” in that voicing contrasts in stops are both articulatorily “difficult” and perceptually non-salient in codas. German final devoicing would then be the result of “optimization,” under the type of model Kiparsky is proposing. But notice that this principle does the acquirer of German no good – such an acquirer receives no input data which contain coda voiced obstruents and thus constructs a grammar without such entities with or without this “optimization” principle. Moreover, for the acquirer of English, this universal principle is irrelevant (and misleading): the input data contain final voiced obstruents, so regardless of how non-optimal or complex such segments are, the grammar such an acquirer constructs must generate them.²⁶ If we contrast the “optimization”

explanation for coda devoicing with a misparsing analysis of the type I have proposed in this chapter, the advantages of the latter are clear. Final voiced obstruents are “articulatorily difficult,” which, if it can be made to mean anything coherent, presumably entails that this aspect of that target articulation is frequently missed (i.e., obstruents in this position are “less voiced” or even devoiced in real-time production). Second, they are not particularly salient perceptually in this context. Clearly these two factors will conspire to lead to changes of the final obstruent devoicing type (and greatly disfavor final obstruent voicing as a change), regardless of *computational* optimality or simplicity. The change arises as a result of strictly extralinguistic factors (articulation and perception).

But there is a more critical difficulty with the analyses of these changes proposed by Kiparsky, one often found in generative analyses of diachronic events. Kiparsky derives the change in surface forms from a change in underlying processes (the extending of a rule), but this is putting the cart before the horse: the rules are posited by the grammar constructor on the basis of the analysis of the surface forms, not vice versa. Kiparsky, in adopting the traditional view of “language” as the domain over which language change is to be analyzed, assumes the existence of the “rules” of the “language” during the acquisition process. However, the acquirer has no access to such rules: only to output of his or her source grammar (and the principles of UG).²⁷ The child cannot change the rules – this would involve first correctly deducing what they were, then “unlearning” the acquired system. The input evidence must support the new, “changed” rule system constructed by the acquirer. But at a stage when *took* had a long *u* – immediately after the Neogrammarian shortening in the core environment had taken place – or when *mad* had a non-tense *æ* (after the regular *æ*-Tensing had taken place), what in the input to the acquirer licensed the reanalysis of *took* as having a short *u* and *mad* as having a tensed *æ*?

This is where the contrast between regularization in the morphological domain and Kiparsky’s proposed “phonological regularization” can be seen most clearly. We can easily construct scenarios whereby a given morphologically complex form, derived via some rule of the lexical phonology requiring an exception feature on the underlying representation of one (or more) of the morphemes involved, could fail to be a relevant part of the child’s input. For example, *‘kine’* (the archaic plural of *‘cow’*) could have been lacking altogether in the PLD of an acquirer at the relevant point or it could have failed to be associated by the acquirer with *‘cow’* (i.e., it could be lexicalized as a separate entity, meaning *‘cattle’* or some such). Nevertheless the speaker might later find himself or herself in a position which required the production of that morphologically complex form (e.g., the plural of *‘cow’*) – leading to default realization (*‘cows’*), since no exception feature will have been stored with that lexeme. The same scenario cannot hold, however, for a phonological representation. To fail to acquire the underlying phonological representation of a given lexeme is to lack that lexeme altogether (the lexicon is a set of

phonological–semantic linkings). One cannot later have to produce some form such as ‘*took*’ or ‘*mad*’ for which one has not posited, on the basis of the acquisition evidence, some phonological representation. Put differently, the existence of a free concatenation process in the morphology will force the speaker to produce many morphologically complex words which were not part of the input evidence during grammar construction (just as a similar concatenation process in the syntactic component will allow the speaker to generate novel sentences). There is no corresponding component of the grammar which freely concatenates the segments of the language, which would then of course lack “exception features,” to create morphemes which were not part of the input evidence. This is the critical difference between “input” and “derived” representations: input representations must be posited during the acquisition process in order to exist at all; derived representations are freely generable. Morphological representations are derived representations, whereas underlying phonological representations are input representations.

How then are we to account for Kiparsky’s three insightful generalizations about *æ*-Tensing quoted above, repeated here for convenience:

First, the environments into which tense *A* is being extended are not arbitrary phonologically. There is no “lexical diffusion” of *A* before voiceless stops, the class of consonants that is systematically excluded from the core tensing environments as well as from the Philadelphia and New York versions of the rule. Second, there are no reported cases of lax *æ* being extended into words which have regular tense *A* in accord with [the core laxing rule,] e.g., in words like *man*, *ham*, *pass*. Third, [æ] changes not to any old vowel, but precisely to [A], the very vowel with which it is in partial complementation by [the core laxing rule].

If the proposals I have made above are on track, then there must be something in the input evidence which causes the data to pattern in this way. I would propose that whatever acoustic feature of *æ* licensed *æ*-Tensing is a gradient feature, present in various environments to various degrees. It was clearly most salient in the “core environment,” present but less prominent in the “extended environments,” and absent or not salient at all in excluded environments. It makes sense, then, that it would be extended in a “phonologically non-arbitrary” manner: the mapping between phonological features and acoustic realization is non-arbitrary, therefore a process dependent on the latter will be non-arbitrary with respect to the former. Since whatever the relevant acoustic feature is, it is most salient in the “core” environments, misanalysis of words like *man*, *ham*, or *pass* as not showing the tensing would essentially preclude any analysis of tensing as relevant to grammar construction at all (if you do not attend to a feature when it is most salient, you can hardly construct your grammar around it in less salient contexts). And of course [æ] changes to tensed [æ̃] (and not to “any old vowel”) for the same reasons it did so in the core environment: it is along the dimension of tenseness that the acoustic ambiguity lies.

It is of some value to point out at this juncture that there are instances in the literature of diachronic processes which pattern just like the *u*:-shortening and *æ*-Tensing events discussed by Kiparsky for which his proposed analysis cannot be invoked. For example, in an interesting case from New Caledonia discussed by Rivierre (1991), we find loss of word-final *k* in a number of dialects. In nearby dialects, both final *k* and final *c* are lost. Slightly further removed, final *k*, *c*, and *p* are lost. Finally, in some dialects all final stops (*k*, *c*, *p*, *t*) are lost. The dialects thus seem to show gradually extending environments for final consonant deletion. The change shows clear “lexical diffusion,” as Kiparsky’s model predicts (Rivierre 1991: 424): “It is obvious . . . that these consonants do not disappear one after the other, with each one waiting for the previous one to have fully disappeared before beginning to disappear itself. The disappearance of each of these consonants is a process which takes place over a certain length of time.” However, in spite of the clear similarity between final consonant deletion in these New Caledonian languages and Kiparsky’s *Paradebeispiele*, the New Caledonian cases cannot be derived by the mechanism proposed by Kiparsky. While we can accept that short-*u* and tense-*æ* result from some feature-filling operation performed on an underspecified phonological representation, zero cannot be the realization of underlying /k/ (or /c/, /p/, or /t/) due to underspecification of /k/’s values for specific features. The key difference here is that final consonant deletion, which is “extending” its environments in the same manner as takes place in Kiparsky’s examples, is not a rule in any synchronic grammar: it is part of the relationship between one grammar (the source) and another (the acquirer’s constructed grammar). The “rule” is merely a description of a diachronic event, not part of any linguistic system, and thus not constrained by the principles of synchronic phonology. In our view this reveals the fundamental shortcoming of Kiparsky’s method: it posits synchronic processes constrained by current theoretical models to account for events which were not necessarily ever part of any individual’s linguistic competence (cf. Janda’s 1990, 1994a, similar criticisms).

The processes taking place *within* a grammar are constrained by the principles of UG – they must be consistent with the computational capabilities of the cognitive system within which they are located. By contrast, the relationships indicated by the “Change” arrow of figure 7.2 do not reside in any cognitive system and thus are in no way constrained by the computational limitations of humans. Since a diachronic event is not dependent upon a human organism actually having a process of the type in question in her or his cognitive system, it does not seem useful to assume that constraints on rule formalism in the synchronic system have any role to play in the account of diachronic misanalyses, which in many, if not all, cases result from extragrammatical features of the human perceptual system. The system constructed as a result of such a change will of course be constrained by UG, and thus represent a possible instantiation of the human computational ability in this area, but obviously we are dealing with three terms in such a situation: the input grammar (constrained by UG), the constructed grammar (constrained by UG), and

the mapping relationship between the two (the set of changes, not located within a human brain, and thus not constrained by UG). We know of no argument that the latter – the mapping relationship – should have the properties of a human phonological system.

Why do we find apparent “lexical diffusion” in the New Caledonian case? Rivierre’s discussion (1991: 425) clearly reveals that we are dealing with a situation in which dialect forms are being freely passed from innovative to conservative dialects and vice versa, precisely the type of sociolinguistic context from which apparent lexical diffusion arises, in my opinion:²⁸

It would nevertheless be simplistic to think that innovations spread and are transmitted unilaterally, from innovating languages to conservative ones. Although the loss of final *-k* and *-c* appears to be spreading to the whole of the Group I lexical stock in HAK, BAT and MAK, evidence shows that these dialects are continuing to borrow lexemes ending in these same consonants from conservative languages to the north. Some of these borrowings are easy to detect because initial *p-* and *k-*, which have remained stable in the conservative languages, have become respectively *v-* and *ɣ-* in the Voh-Kon dialects.

While there is no detailed study of the contact between *æ*-Tensing and non-Tensing dialects of North American English which would allow us to account for the attested pattern of borrowings (and thus apparent lexical diffusion), in the presence of clearly parallel events elsewhere which can be seen to be due to contact, we see no need to posit a unique mechanism, “lexical diffusion,” to account for the North American case.

Diffusion events such as those in New Caledonia do, however, afford another possible explanation for the extending of the context of rule applicability: hypercorrection. This results when speakers whose grammars generate stigmatized forms attempt to acquire “prestige” grammars, but have insufficient contact with such grammars to permit them to deduce the precise conditions which govern the difference between their native grammar and the prestige source. They may, under such circumstances, construct grammars which generate prestige “segments” in contexts in which the prestige dialect in fact agrees with their own original forms – that is, they overgeneralize the differentiating context.²⁹ This type of change – call it “imperfect diffusion” – may be distinguishable from “imperfect transmission” (the basic process of “change,” as discussed above) in that it may differ fundamentally in what constraints it observes. It will straightforwardly give rise to “rule extension” of the type discussed by Kiparsky: the “core context” would of course be the original differentiating change (which was “hypercorrected” by the stigmatized speakers) – due to imperfect transmission and regular (in Neogrammarian terms) – and the “extended contexts” would have resulted from various hypercorrections. If such a mechanism underlies Kiparsky’s cases, it seems unlikely that the “lexical diffusion” properties of the “extended context” changes are to be attributed to a structural feature at all: since contact will be required to trigger

the hypercorrection in the first instance, and since we can assume (because of the imperfect nature of the diffusion – i.e., the misanalysis of the context for the prestige forms) that the amount of contact with the prestige dialect was somewhat limited, we would predict straightforwardly that these “hypercorrecting” speakers would show a mixture of forms: “hypercorrect” ones, correct (i.e., prestige) ones, and of course ones from their native grammars which were not “corrected” (because of the speakers’ imperfect command of the prestige dialect). This will give the appearance of lexical diffusion.

4.2 Structure-dependence

The Neogrammarians claimed that sound change operated without regard for its effects on the language system, that is, it operated blindly. In this they were certainly wrong.³⁰ As Kiparsky (and others before him) has pointed out, any model which licensed sound change without regard for the resulting phonological system could produce, through normal diachronic processes, phonological systems which are not within the computational capabilities of the human organism – that is, phonological systems which violate fundamental principles of UG. Since this cannot happen, by definition, sound change must be constrained in its effects such that the resultant system is a possible human phonological system – it cannot therefore proceed blindly.

It would seem to follow from this (and such reasoning is not uncommon, though usually less explicitly formulated) that for a given change $A > B$, the set of grammars which contain feature A (and thus could conceivably show the $A > B$ change), $G_{A_1}, G_{A_2}, G_{A_3}, \dots$ will fall into two classes. Labeling the grammars which would result from the occurrence of $A > B$ in $G_{A_1}, G_{A_2}, G_{A_3}, \dots$ by means of $G_{B_1}, G_{B_2}, G_{B_3}, \dots$, we can assume that some G_B will be possible human languages, and some will not (given principles of UG). Thus for some G_A , $A > B$ is a possible change, while for other G_A , it is not. The G_A for which $A > B$ is a possible change must share some set of structural features (such that substitution of B for A results in a possible human language); these will of course be the structural preconditions for the change $A > B$.

It is important to be clear, given the claims of the relevant section of Kiparsky’s paper (to be discussed below), that we are talking of “possible” and “impossible” change events for a given G_A , not “likely” or “unlikely” change events. It is possible that there are structural features which *favor* a particular change (making it more trivial) or *disfavor* a particular change (making it less trivial), but these have nothing to do with the principles of UG, which only require of a given change that the result of its taking place in a given grammar will give rise to a *possible* human linguistic system.³¹

There is, however, a serious problem with the line of reasoning concerning structure dependence outlined above. It assumes, critically, that the grammar changes “one rule at a time.” There is, however, nothing in the model of grammar transmission which requires, or even favors, such a conception of

change. The possibility of multiple simultaneous changes in a grammar during the transmission process makes the argument considerably more complex, since for any given G_{A_x} for which a simple change of $A > B$ would result in an “impossible” grammar G_{B_x} , a simultaneous change of the type $C > D$ could render the resulting grammar (G_{A_c} , changes $A > B$, $C > D$, resulting in G_{B_D}) fully acceptable, in UG terms. Therefore the conclusion reached above, that for some G_A a change of the type $A > B$ is an “impossible” diachronic event, will hold only if $A > B$ is the *only* change under discussion. But since grammar transmission is never constrained in this way (“one change at a time”), no change, even one for which the result of applying $A > B$ (as the only change) to the set of G_A would invariably result in an impossible human linguistic system (i.e., for which all G_B are ruled out by UG), can be considered an “impossible” change on structural grounds alone (although it may, of course, represent an impossible acoustic misparsing).

The result is that there is in fact no structure-dependence of the type argued for above: no structural feature (or set of features) of the input sources directly precludes a given change event. The only constraints of this type would have to be much more complex than the literature normally assumes. For example, if it were the case in the scenario sketched above involving the changes $A > B$ and $C > D$ that all changes of the type $C > D$ (i.e., all changes which would make the result of the application of $A > B$ to G_A lead to an acceptable result for UG) were excluded in their own right, which itself involves proving that all changes which could make the $C > D$ -type changes possible are also excluded (and all changes which would make the changes which would make changes of the $C > D$ -type possible are excluded, etc., leading to a potentially infinite line of argumentation), then and only then could we exclude $A > B$ as a possible diachronic event. The prospects for constructing actual arguments which would support a claim that a given change event can be excluded as impossible for a given input grammar (or set of input grammars which share some structural feature) are thus rather bleak, in my view.³²

This result is, in fact, hardly surprising. If the core context for change is reanalysis during the acquisition period, there can hardly be structure-dependence of the type usually advocated. The structure is not given; it does not exist for the acquirer; it is, in fact, what is being constructed. Only the output of the acquirer’s source(s) is given. Any analysis which is consistent with this output (and of course with the principles of UG) is possible. The constraints on change will therefore be a combination of the set of possible (mis)analyses of the input data (many of which are presumably ambiguous – that is, consistent with more than one grammar) and the global constraint that holds that the result of opting for various choices made possible by these ambiguities be consistent with UG. That is, the set of possible analyses of the data will generate a set of “possible” changes: $A > B$, $A > C$, $C > D$, $E > F$, etc., and the principles of UG will demand that the grammar constructed show a subset (potentially null) of those changes which result in a grammar which is consistent with the principles of UG. The constraints provided by UG are

universal, of course, and thus can show no dependence on the structure of the input sources. The candidate set (before the constraints of UG) of “possible” changes is constrained only by possible misanalyses of the input strings provided to the acquirer: some of these misanalyses probably follow from non-linguistic aspects of the human perceptual system, others from more directly linguistic concerns, but they are not of the type that the possible Bs posited for a given A in the input sources are constrained by the structural features of the grammar containing A – they cannot be, as the child does not know what the structural features of the grammar containing A are.³³ It is precisely those features which the grammar, once constructed, is a formulated hypothesis about.

What are Kiparsky’s arguments in favor of the structure-dependent nature of sound change? There is not much data-oriented argumentation in this section of Kiparsky’s paper – the arguments are more conceptual. The first offered can be seen in the following quotation (section 2.1):

Jakobson was in fact able to cite fairly convincing long-term tendencies in the phonological evolution of Slavic, involving the establishment of proto-Slavic CV syllable structure by a variety of processes (degemination, cluster simplification, metathesis, prothesis of consonants, coalescence of C + *y*, coalescence of V + nasal) . . . Since it is human to read patterns into random events, it would be prudent to look at such arguments with a measure of suspicion. But the number and diversity of phonological processes collaborating to one end do make Jakobson’s case persuasive.

Such “long-term” conspiracies, spanning hundreds of years in the case of Slavic, are frequently cited in the literature. They clearly argue against the “blind” operation of sound change, a thesis which we have no desire to defend in any event, if they exist. The question of course is: how can they exist? How can a language which does not have a restriction against closed syllables (as pre-proto-Slavic did not) acquire a compulsion to develop one, a compulsion which achieves its desired goals only hundreds of years later? Kiparsky acknowledges that this “mysterious mechanism of orthogenesis . . . itself has no explanation” (section 2.1). Indeed, “has no explanation” is rather weak in its criticism of such a hypothesis. Where would such a conspiracy reside and how would it exercise its influence on grammar construction over such a long span of time? Why would a “language” (if we even wanted to admit the relevance of such a concept into our considerations) conspire for generations to attain the point where it has only open syllables, only to surrender this feature shortly thereafter?

Kiparsky’s own attempts to resolve this difficulty cannot, I think, be deemed successful. His proposal can be seen in the following quotation (section 2.1):

Traditionally, the acquisition of phonology was thought of simply as a process of organizing the primary data of the ambient language according to some general set of principles (for example, in the case of the structuralists, by segmenting it

and grouping the segments into classes by contrast and complementation, and in the case of generative grammar, by projecting the optimal grammar consistent with it on the basis of Universal Grammar). On our view, the learner in addition selectively intervenes in the data, favoring those variants which best conform to the language's system. Variants which contravene language-specific structural principles will be hard to learn, and so will have less of a chance of being incorporated into the system.

Note first that this is an inherently conservative principle – it favors minimal change. It can hardly explain, and indeed directly counter-generates, the “long-term tendencies” posited by Jakobson for Slavic. Since Slavic did not have a constraint against closed syllables when Jakobson’s “conspiracy” began (indeed, it did not have such a constraint until Jakobson’s conspiracy was completed), Kiparsky’s proposal would predict that changes which favored a restriction to CV-syllable types (i.e., that disfavored coda-consonants) would be selected *against* by the acquirer, rather than favored (since a restriction against coda-consonants would “contravene language-specific structural principles”).

Moreover, the proposal demands that the acquirer, during the acquisition process, have access to “language-specific structural principles,” though these are presumably available only *after* the specific language in question has been acquired. This conceptual difficulty also undermines, in our view, Kiparsky’s “priming effect” proposal (section 2.1): “Redundant features are likely to be phonologized if the language’s phonological representations have a class node to host them.” Once again, one of the key challenges to the acquirer is precisely to determine which class nodes need to be present in the language’s phonological representations. Changes such as “phonologization” are not dependent upon existing representations (which the child cannot directly access), but rather represent solutions to that challenge which differ from those opted for by previous generations.

The data cited in support of this principle are replete with empirical difficulties. The first argument provided by Kiparsky concerns tonogenesis (section 2.1): “The merger of voiced and voiceless consonants normally leaves a tone/register distinction *only in languages which already possess a tone system*”³⁴ (italics in original). Though I do not know of a large number of instances of tonogenesis in non-tonal languages which are not in contact with tonal languages, such cases clearly exist. The Huon Gulf and New Caledonian cases come to mind, as does, arguably, Scandinavian – see Ross (1993) and Rivierre (1993).

The next case mentioned concerns compensatory lengthening: “De Chene and Anderson (1979) find that loss of a consonant only causes compensatory vowel lengthening when there is a pre-existing length contrast in the language.” Kiparsky himself notes the exception provided by Occitan to this claim (n. 16).³⁵

Finally, the third piece of empirical support offered by Kiparsky concerns the genesis of geminates: “total assimilation of consonant clusters resulting in geminates seems to happen primarily (perhaps only?) in languages that already have geminates (Finnish, Ancient Greek, Latin, Italian). Languages with no pre-existing geminates prefer to simplify clusters by just dropping one of the

consonants (English, German, French, Modern Greek)." Ancient Greek and Latin, in any event, frequently "simplify clusters by just dropping one of the consonants" (rather than all clusters giving rise to geminates).

Of course none of these empirical difficulties is of much significance, given how the "priming effect" is stated: it is not a claim about the possibility of certain changes (and thus can play no role in the development of a theory of constraints on diachronic phonological events), but merely one about the "likelihood" of certain changes (and thus could be useful in deriving a triviality index for a given change in a given language). Since all of the changes involved are optional (i.e., they need not take place) and since the same changes may take place in languages which lack the necessary "priming effect" (they are just, if Kiparsky is right, "less likely"), one would not want to label such changes "structure-dependent" (which implies that they have structural preconditions to their occurrence and will be triggered under these structural conditions).

4.3 *Naturalness*

This brief section of Kiparsky's paper is, in my view, marred by a lack of clear distinction between constraints on synchronic phonological processes and constraints on diachronic events. There is no *a priori* reason to believe that synchronic phonological systems and diachronic events are constrained by principles which are at all the same. Indeed, there is a very real danger that many constraints proposed on synchronic phonological systems (proposed because there are no known exceptions in the languages we have studied so far) are in fact not synchronic constraints at all. Consideration of how each of these types of constraints – synchronic and diachronic – should be deduced reveals little connection between the two: synchronic constraints should ultimately reflect the real-time computational capabilities in the area of phonology of the human organism. They follow from the "phonological" portion of UG. Diachronic constraints, on the other hand, should result from a theory of possible misanalyses of input data. The relationship between the two is hierarchical: the phonological part of UG constrains possible diachronic events in that no acquirer can subject his or her input data to an analysis which results in an impossible (given the constraints of UG) phonological system, because the human organism is not capable of constructing such systems. Diachronic events on the other hand have no effect on UG, given the uniformitarianism hypothesis (i.e., assuming that at the time depths within which historical linguists normally operate there have been no "evolutionary" changes in UG). However – and here's the rub – diachronic events provide us with the bulk of our evidence for "possible" phonological rules: the morphophonemic alternations which form the backbone of phonological rule systems are the result of diachronic events. It is entirely possible, in my view, that the set of possible phonological processes is a superset of the set of possible diachronic misanalyses, in which case no cross-linguistic survey of phonological processes – which is necessarily

restricted to those processes which have resulted from diachronic misanalyses – will reveal the actual computational capabilities (in the phonological domain) of the species.

This impacts Kiparsky's argument in the following way: if some of the proposed constraints on phonological systems are in fact not constraints on the organism (i.e., deducible from UG), but rather constraints on diachronic events, incorrectly analyzed as constraints on phonological systems, then the "structure-dependence" of diachronic events which Kiparsky attributes to "natural" phonological processes is a mirage. The structures upon which the diachronic events appear to depend are mere synchronic statements of constraints upon possible diachronic events. Indeed, it appears that the diachronic filter, which, as simple laboratory experimentation on the confusion matrices generated by perceptual testing reveals, favors some misanalyses over others (rather than absolutely precluding disfavored misparsings), is the reason why most claims about "naturalness" and "markedness" are statistical, rather than absolute claims.³⁶

5 Conclusions: The Value of Historical Linguistics

I have attempted to do two things in this chapter. First, I have tried to demonstrate that there is a well-defined type of diachronic phonological change, plausibly motivated by well-established principles of acquisition, which has the properties originally proposed by the Neogrammarians. Such changes are *regular* and seem to result from *purely phonetic conditioning*. Second, I have surveyed the recent critical review of the Neogrammarian hypothesis presented in Kiparsky (1995), attempting to reveal the shortcomings in many of the underlying methodological assumptions of that work.

In the course of the latter discussion I have touched upon an issue which I believe underlies the central importance of diachronic linguistics to the theoretical linguistic enterprise. The primary goal of theoretical linguistics is to characterize the innate linguistic endowment, UG. One of the principal methods for uncovering properties of UG has been, plausibly enough, to examine the limits on the diversity of human linguistic systems through cross-linguistic research. Such research has generally been conducted with a sensitive awareness to the possibility of sampling error arising from the fact that the set of observed human grammars is a presumably small subset of the set of possible human grammars. I have argued that there is another, somewhat more insidious, issue which arises from such cross-linguistic surveys – the "diachronic filter." It seems to me likely that the relationship between computationally possible human grammars, diachronically possible human grammars (i.e., those which can come into being from existing initial conditions), and attested human grammars is roughly as in figure 7.4.

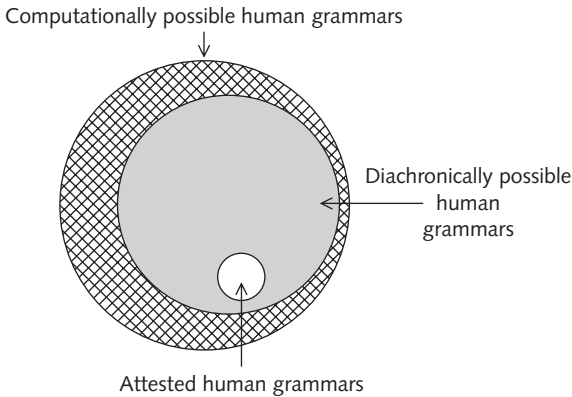

Figure 7.4 The diachronic filter

There are two ways in which the “diachronic filter” can distort the range of attested grammars. First, the impossibility of certain change events may, given initial conditions, preclude the coming into being of certain grammars. For reasons I have alluded to in section 4.2 above, I do not believe that the skewing introduced in this way is likely to be particularly significant. The second influence of the diachronic filter is, however, quite significant for certain approaches to discovering the properties of UG. As can be easily confirmed by a survey of the literature on speech-production and speech-perception, the set of errors introduced by these interface systems is not random. Certain deviations from the target articulation occur with far greater regularity than others. Similarly, some misparses by the speech-perception system are far more likely, statistically, than others. While these factors do not provide absolute constraints on diachronic development (since they are themselves merely statistical generalizations), they certainly favor certain phonological changes, which are themselves in large part a function of the interface systems, over others.

This has serious implications for attempts to develop an account of the human linguistic endowment based on arguments of an oft-invoked type: for example, it has often been explicitly argued that since X is widely attested in human grammars, it should be made to follow from the model being developed (presumably of model of UG) in some straightforward manner. Assimilation in feature-geometric phonology and the “well-formedness” (or “markedness”) constraints of Optimality Theory are good examples of this type of reasoning.³⁷ Building a general model of the phonological component of UG around such (statistical, rather than absolute) cross-linguistic generalizations seems to me to shift the responsibility for explaining these generalizations inappropriately from diachronic linguistics to UG. If, as we have indicated, the development of a comprehensive and restrictive theory of phonological change demands detailed consideration of the way in which the production and perception interface systems shape the PLD made available to an acquirer, it is unproductive

and redundant to build the effects of these systems into the computational component of UG phonology. In other words, a UG without these built-in prejudices will display the same set of grammars as one with – since the filtering role of the interface systems will restrict the type of data an acquirer receives in any event.

The process of discovering precisely which cross-linguistic generalizations can be explained as due to the effects of the diachronic filter and which cannot is, therefore, central to the enterprise of discovering the properties of UG. The failure to recognize the critical role played by diachrony in shaping the set of attested human languages has consistently led phonologists astray, engendering the attribution of the epiphenomenal effects of extragrammatical interface systems to UG itself.

The stunning success of the comparative method reveals that the proposal that Neogrammarian sound change exists must be empirically well grounded. In attempting to come to understand just how such changes are possible, diachronic linguistics has a key role to play in the search for the essential properties of the human linguistic endowment.

NOTES

- 1 “Wenn wir daher von konsequenter Wirkung der Lautgesetze reden, so kann das nur heissen, dass bei dem Lautwandel innerhalb desselben Dialektes alle einzelnen Fälle, in denen die gleichen lautlichen Bedingungen vorliegen, gleichmässig behandelt werden. Entweder muss also, wo früher einmal der gleiche Laut bestand, auch auf den späteren Entwicklungsstufen immer der gleiche Laut bleiben, oder, wo eine Spaltung in verschiedene Laute eingetreten ist, da muss eine bestimmte Ursache und zwar eine Ursache rein lautlicher Natur wie Einwirkung umgebender Laute, Akzent, Silbenstellung u. dgl. anzugeben sein, warum in dem einen Falle dieser, in dem anderen jener Laut entstanden ist.”
- 2 It should not go unnoticed that the German term here is “Lautgesetz,” that is, “sound law.” Technically, the Neogrammarians distinguish between “sound law” and “sound change” (*Lautwechsel*), the latter of which I will call, in keeping with modern practice, “sporadic sound change.”
- 3 See, for example, Paul (1880, quoted from 1975: 64): “It is not in this case a question of the changing of the elements out of which speech is constructed by shifting, but rather of a substitution of these elements in certain individual cases” (“Es handelt sich hierbei nicht um eine Veränderung der Elemente, aus denen sich die Rede zusammensetzt, durch Unterschiebung, sondern nur um eine Vertauschung dieser Elemente in bestimmten einzelnen Fällen”).
- 4 For a more comprehensive discussion, see Hale (1997).
- 5 I am therefore starting out from fundamentally different assumptions than those of several other historical

- linguists who have expressed themselves on this point. For example, Labov (1994: 45) states "I would prefer to avoid a focus on the individual, since the language has not in effect changed unless the change is accepted as part of the language by other speakers." Similarly, Hopper and Traugott (1993: 38): "Methodologically it is certainly preferable to recognize change only when it has spread from the individual to a group." This "E-language" conception of the object of linguistic study (Chomsky 1986: 19ff) seems to me to create more problems than it solves – I believe, with Chomsky, that "I-language," that is, the grammar, provides the most productive starting-point for an understanding of linguistic phenomena, including change.
- 6 It seems to me unlikely that sociolinguistic factors play any central role in the stages of L1 acquisition most relevant to the study of certain types of change.
 - 7 This entails, in my view, that there are probably no *structural* constraints on diffusion events in the most general case – that is, that any possible innovation could in principle diffuse given the most favorable sociolinguistic context.
 - 8 The modules given in figure 7.1 are still heavily underdifferentiated in the strictly extralinguistic domains – a fact which will not impede us in our present investigation.
 - 9 In my view, this grammar is a unique entity established at the end-point of the acquisition process and not subsequently modified during the lifetime of the speaker. A speaker may, of course, learn additional grammatical systems but the learning of these subsequent systems is an *additive* rather than a *replacement* operation – it thus differs fundamentally from the "stages" of knowledge development during the L1 (and perhaps L2) acquisition process, where passage from one stage to another involves replacement of one's current knowledge state by a different one.
 - 10 For arguments that the issues arising from multiple sources may be less significant than they seem at first blush, see Hale (1997).
 - 11 All diffusion will be gradual, hardly surprising given that "diffusion" means "the act of spreading," involving either time or space (though spatial diffusion can, and usually does, take time).
 - 12 The methodological problem of accounting for the stunning success of the comparative method – which depends crucially on Neogrammarian assumptions – is generally neglected by those who reject the Neogrammarian hypothesis of regularity.
 - 13 I leave to one side here the possible interaction of this change with other change events. In general, in the conception of change given here (a relationship between an input source and the grammar resulting from an acquirer being exposed to that source), such complications will be minimized.
 - 14 I follow standard Oceanic practice in representing the velar nasal with the orthographic sequence <ng>.
 - 15 Compare PPN **langi* 'sky' > Maori *rangi*, with unmetathesized **l* and **ng*.
 - 16 Note that the change may have taken place any arbitrary number of times – it is the chance coming together of an innovation in the grammar of a particular individual who happens to occupy the right kind of sociolinguistic nexus which leads to its presence in the historical record of Maori.

- 17 It is worth pointing out that even under a rather different, perhaps more sophisticated, view of what should count as “sound change” it may still be most useful, methodologically, to keep sharply distinct “regular” and “sporadic” events. One could argue that rather than using the *environment* to classify a change as “lexical” or “phonological,” one might want to ask just which aspects of the output of G_1 formed the basis for the misanalysis by the acquirer. Under this conception, the *ngaro* case will have a very different status from the “*couch*” case. In the former, it seems likely that the misparse which gave rise to the metathesis was phonetic in nature, while in the latter, this seems most unlikely. But even under this conception, there is clearly a difference between the misanalysis of PPN **lango* and that involved in a “regular” sound change such as * $p^h > \phi$. In the **lango* case the misparse was idiosyncratic – it did not lead the acquirer to treat all subsequent instances in his or her input data of *l...ng* as *ng...l*. By contrast, in the case of the misparse of * p^h as ϕ , an acoustic “chunk” involving labiality and continuancy was treated as representing a single target segment with simultaneous realization of these features (whereas in the acquirer’s source it had been generated as a single “contour” segment with sequential realization of these features). This particular parse of that acoustic “chunk” was then applied to all subsequent input data of the relevant shape – hence the “regularity” of the change.
- 18 The set of claimed “causes” for change in the literature is quite extensive. This list includes many “constant” factors, which, as Bloomfield (1933: 370–1) already pointed out, can never “cause” change, since they are as present for any preceding generation as they are for the one in question. The list of such “constants” invoked as causes of change is remarkably long. It includes simplification (generally with no metric provided), markedness, functional considerations (ease of articulation or maintaining of contrasts), structural considerations (gap-filling in phonological systems, cross-categorical “harmony” in phrase structure), phonological “repair,” “child language,” and even UG itself.
- 19 The graphic grossly oversimplifies the internal complexity of the components involved.
- 20 Epstein et al. (1996: 20) state that “the way the corresponding instructions are interpreted by the articulatory-perceptual performance system is presumably just as universal as the way the LF instructions are interpreted by the conceptual-intentional performance system.” However, in the case of both the production and the perceptual system, in spite of this universality, the acquirer may be unable to “undo” the effects of these components. They may be universal and systematic, but still “chaotic” in the technical sense (i.e., sufficiently multifaceted and contingent as to be computationally intractable).
- 21 Perhaps not even then – the acquisition algorithm must be able to deal with speech errors without distorting the hypothesis space of the acquirer.
- 22 I oversimplify somewhat for expository purposes here. There may, in fact, be default-value fill-in rules applying at different levels of the phonological representation –

- that is, there may be a series of such rules within the phonological component, rather than a single battery of them.
- 23 The assignment of stress normally demands that one also determine syllabification and potentially moraic structure. These also need to be pre-specified in the “exceptional” cases, but determined by rule in the default cases. As pointed out by Inkelas (1994), this is somewhat awkward for underspecification theory, since syllabic and moraic structure may be perfectly well formed according to the default rules for building such structure, but nevertheless would have to be pre-specified in such cases.
- 24 Examples cited by Kiparsky include *cook, hook, shook, rook, brook, crook, hookah*.
- 25 Note that from this and other claims of his paper, Kiparsky is working with traditional notions of “language” (E-language) and “change.” The outcome is variable only from the point of view of “the English language” (my dialect, e.g., has short *u* in *snook* and *snooker*, *u*: in *gadzooks* and *speek*, and lacks the other example lexemes altogether – it shows no “variation”). In a chart (21.1, p. 643 (table 6.1 in this volume)), he claims that Neogrammarian sound change is “rapid” while lexical analogy and lexical diffusion are “slow” – positing extended temporal dimension for change events better conceived of, in my view, as a sequence of discrete and independently motivated events. This, once again, is only consistent with an “E-language” notion of the object of diachronic linguistic study.
- 26 For a detailed discussion of these issues see Hale and Reiss (1998).
- 27 Kiparsky recognizes the key role of acquisition in change elsewhere in the article.
- 28 HAK, BAT, and MAK are three relevant New Caledonian languages. See Rivierre (1991). Cf. also Janda (2001: 67).
- 29 While the limited contact would license “undergeneralization” of the differentiating context as well, it seems likely that the speaker’s desire to avoid “stigmatized” output would favor overgeneralization.
- 30 Note that it is frequently concluded that since the Neogrammarians themselves linked the fact that sound change operated “blindly” with their claim that it was regular, disproving the claim that sound change is “blind” in its operation is equivalent somehow to disproving the regularity hypothesis. As we have seen in the discussion above, the regularity hypothesis – for the relevant types of change events – is not deduced from any principle of “blind” application, or from any principle which entails that sound changes will take place without regard for the resulting phonological system. Thus, giving up the notion that sound change operates “without regard” for the phonological system should not be taken as relevant in any way to the exceptionlessness hypothesis.
- 31 The structural preconditions which “favor” a given change are those features responsible for the ambiguity in the output along the change dimension which licenses reanalysis by the acquirer.
- 32 The place to seek constraints on possible change events is not, therefore, in the underlying structure of the input sources, but rather in the set of possible misparsings of the output generated by the grammar being acquired.

- 33 One could acknowledge an indirect connection, inasmuch as the structural features (including of course the input representations) of the source grammar partially determine the output of that grammar. But it hardly seems worthwhile to pursue this indirect connection, when an explicit theory of the connection between misanalysis and all aspects of the acoustic output (not just those aspects of it conditioned by structural features of the grammar) will be required in any event. Surely the constraints should build around this more direct relationship.
- 34 Kiparsky goes on to acknowledge that areal effects can trigger tonogenesis in non-tonal languages.
- 35 Observe that many of the languages which have a pre-existing length contrast and show compensatory lengthening for the simplification of some clusters do not show compensatory lengthening for the simplification of others, thus lessening the force of Kiparsky's use of "are likely to be phonologized" in the statement of the priming effect. Indeed, as De Chene and Anderson (1979) already argued, the nature and syllabic structure position of the lost segment are very relevant to whether compensatory lengthening occurs, yet these are matters quite unrelated to the question of whether the language's phonological representations have a class node to host certain "redundant" features.
- 36 The work of Ohala (1981a, 1983aff) is particularly instructive in this regard. (See Ohala, this volume, and his references for further discussion.)
- 37 By positing that well-formedness constraints are highly ranked in the initial state (UG), OT-approaches to phonology have embedded into the model these cross-linguistic generalizations. For a criticism of this approach from a general learning-theoretic perspective, see Hale and Reiss (1998).

8 Variationist Approaches to Phonological Change

GREGORY R. GUY

In the last four decades, studies of language variation have brought a new perspective to the problems of historical linguistics. Previously, diachronic studies had been largely confined by evidentiary limitations to post-hoc analysis of the end-products of language change. But beginning with William Labov's pioneering studies of sound change in Martha's Vineyard (1963) and New York City (1966), it has been possible to investigate language change in progress, while it is actually under way, and thus to study the social and linguistic mechanisms of change.

Saying this is not to devalue the considerable achievements in this area of other historical methodologies. The linguistic aspects of change processes have been the subject of numerous insightful theoretical proposals, dating back to the Neogrammarians and beyond. The social spread of language change has been a matter of keen interest in dialectological studies, and early attempts to study sound change in progress can be found in works such as Gauchat (1905) and Hermann (1929). But it was Labov's focus on the fact of sociolinguistic variation, and the theoretical treatment of variation proposed by Weinreich et al. (1968), that opened the way to more intensive and productive study of change in progress.

The focus on variation has opened up three new areas of investigation for studies of language change. First, studying change in the speech-communities that surround us constitutes a revolutionary advance in the availability of evidence, and makes possible dramatic improvements in the observational and descriptive adequacy of our accounts of language change. Information about the changes of the past is always fragmentary, limited by historical accident. But evidence about the changes of today is limited only by our energy and diligence at data collection. Hence scholars of language change now have available detailed pictures of changes which can be made accurate to whatever level of refinement may be required.

Second, as a consequence of these evidentiary advances, we can now undertake serious study of the social mechanisms and motivations for language

change. These had long been the subject of speculative inquiry, but with detailed evidence available on changes in progress in a speech-community, and the prospect of testing our models of events against the observable reality of changes as they unfold, the social basis of language change can now be the subject of serious study on a sound empirical footing.

Finally, variationist investigations of language change offer a completely new perspective on the linguistic mechanisms of change. The structural view of linguistic organization that has dominated theoretical thought in linguistics for most of this century makes change appear puzzling and dysfunctional. If the elements of language are defined by their place in a finely articulated categorical mental grammar, then how and why do they change at all? How does a system based on discretely opposed categories sustain the ultimate indiscretion of mergers, splits, and other transmutations of the categories? Why does change not act like grit in the gears of a machine, producing catastrophic failure rather than organic adaptation? Yet seen in light of the fact that all speech-communities and all speakers regularly and easily use and manipulate linguistic variables and variable processes, the puzzle disappears. The linguistic processes that yield change are diachronic extensions of variable processes that are extant in synchronic usage and synchronic grammar.

1 Variation and Change

The variationist approach to change sees linguistic variation and linguistic change as two faces of the same coin, two different aspects of the same phenomenon. All human speech-communities exhibit synchronic variation on a large scale, and language change across time is one outcome of this variation; conversely, linguistic variation is the inevitable synchronic face of long-term change. It is taken as virtually axiomatic that there is no change without variation. It is absurd to suppose that any speech community ever changes a phonological characteristic, or indeed any feature of language, abruptly, totally, and instantaneously, without passing through a period where what will turn out to be the "old" form and the "new" form are both simultaneously present in the community. Minimally, the variants will be found as features of social or regional dialects, but normally they will also occur as linguistic variables in the usage of each individual in the transitional generations.

Such alternation is what we find happening today in the course of changes-in-progress going on in the communities around us. For example, English short-*a* has been undergoing a sound change involving tensing and raising in a number of English-speaking communities around the world over about the last fifty years; where this change is still under way, we find alternation between leading ([e^ə, i^ə]) and lagging ([æ]) variants (cf. Labov et al. 1972). These variants are stratified socially and generationally, and different dialects are located at different points on the change and have different details of

phonological and lexical conditioning, but most speakers in the changing communities have a range of productions spread out along the axis of the shift. Similarly, Hibiya (1996) documents a change in Tokyo Japanese over the last century involving denasalization of the velar nasal in word-internal position, and finds that over 90 percent of the speakers in the changing generations vary in usage between /g/ and /ŋ/, even while they form a distinctive progression in apparent time toward ever-higher rates of /g/. Likewise in New Zealand, the current merger between the EAR and AIR word-classes finds a huge majority of speakers in the generation in the middle of the change showing variation between merged and unmerged articulations (Maclagan and Gordon 1996; see also Holmes and Bell 1992).

Projecting backward from such evidence in accordance with the Uniformitarian Principle,¹ the same situation has logically obtained for all historical changes. Surely, Middle English speakers did not all wake up one morning in 1450 and discover that they had experienced a Great Vowel Shift overnight. Rather, leading and lagging pronunciations must have coexisted as sociolinguistic variables in the speech-communities of England for several generations, and in all communities that have undergone change.

It is important to note, however, that it is not necessarily the case that all variation leads to change. Although linguistic theory has traditionally idealized language as being discrete and homogeneous, variation studies suggest that such a view is observationally, descriptively, and explanatorily inadequate. In the theoretical framework that has grown out of the work of Weinreich et al. (1968), variation is seen as an *inherent* feature of linguistic structure, and not merely a way-station on the road from one categorical state of the grammar to another. Hence, we must allow the possibility that some variables persist in active alternation in the speech community, and indeed in the speech of each individual, for generations, without resulting in one variant supplanting all others.

The more we know about the history of phonological variables, the more candidates for such "stable variation" emerge. One example is the *-in'/ing* alternation in English (*runnin'* versus *running*) which apparently originated in a partial merger of verbal and nominal affixes in Middle English, but has persisted in the vernacular language for over six centuries, even despite the standardizing pressures of the prestige dialect and the uniform orthography. Another, not quite so stable but at least persistent, is the alternation between stop, affricate, and fricative realizations of the Germanic interdentalals (/θ, ð/). This alternation is an active sociolinguistic (and/or "fast speech") variable in many English dialects today and evidently has been for some time. In the dialects I am familiar with, there is no evidence of a broad cross-generational shift toward categorical use of one or the other alternant. In some Germanic languages the stop variant has prevailed diachronically, but not without a checkered history that suggests variability over a fairly long term. This kind of evidence suggests that synchronic variation is a necessary but not a sufficient condition for change.

The identification of variation as the synchronic face of change has far-reaching implications for the theory and practice of “historical” linguistics. It means, for example, that the processes and mechanisms of diachrony should be reflected in synchronic variation. Hence the evidence of variation can be brought to bear on historical issues, and the world becomes an enormous laboratory for the study of language change. Many of the classic issues about language change become newly accessible if they can be investigated in the linguistic variation of the present: discrete versus continuous change, gradual versus abrupt, phonetic versus phonological change, functionalism, directionality, Neogrammarian regularity versus lexical diffusion. Some issues, of course, will not: variation studies are unlikely to offer evidence bearing on the validity of the Amerind hypothesis (Greenberg 1987), or the date of the *centum–satem* split in Proto-Indo-European. But though it may say little about specific *events* of the past, the data of the present can say much about the *nature* of language change. What are the mechanisms by which the output of the grammar changes across time? How does the mental grammar of one generation, or one speaker, compare or differ from the grammars of their predecessors? How and why does one alternant come to be used preferentially, and eventually categorically, supplanting all others? What are the factors that influence the preferential selection of a variant? What are the origins and explanations of change? The inherent and orderly linguistic variability that surrounds us offers a broad new arena in which to search for the answers to questions such as these.

2 Modelling Change

The conventional representation of sound changes, as rewrite rules like (1), glosses over the complexity of variation during the course of the change:

$$(1) \quad x \rightarrow y$$

At best, notations of this kind express the presumably categorical end-points of a change. Given the fragmentary, mainly orthographic, evidence that we have of all changes prior to the invention of sound recording devices in the late nineteenth century and thereafter, it is often difficult or impossible to say much more about the nature of the intervening period of variation. But in light of the accumulated evidence about the changes of today, which can be studied in phonetic detail, we conclude that variation in the course of change is a linguistic universal. Hence we may best understand the basic mechanism of diachronic change in terms of a kind of competition between, or selection from among, a pool of variants. Within a speech-community, indeed within the productions of every individual, there is a range of articulations that realize any given phonological unit. Therefore, what we understand as change consists of the observation that over time, normally over at least several generations,

some of the variant articulations realizing a given phonological unit become more frequent than others. In the extreme case, which is what is represented by formalizations like (1), one articulation may become universal, completely replacing all the others that it formerly alternated with.

It is important to note that the alternant articulations present in the course of a change are not ordinarily in “free” variation, in the sense of being statistically random. Rather, they occur in statistically predictable patterns. The speakers in a community will cluster around a particular central frequency of use for a variant, and this central frequency may well differ from community to community. Across time, the central frequency will change: in the early years of an innovation, everyone in the community will use the new form at a low rate, but when the change is well advanced, speakers will systematically use it at a high rate. To be sure, there will be statistical fluctuations, such as sampling errors, just as in any statistical analysis. But the rates of use of a variable will be predictable in the statistical sense: that is, factors like the dialect or speech-community from which a sample is drawn, and the point in time at which it is produced, will predict the probability of usage of a variant at a better than random level. In the terminology of Weinreich et al. (1968), the usage of the variants will show *orderly heterogeneity*.

A formal treatment that more accurately represents what is going on during the change, rather than limiting itself to a summary of the end-points, will be achieved if we represent the change not as a categorical statement of outcome as in rule (1), but as a quantified or “variable” rule (Labov 1969; Cedergren and Sankoff 1974). The customary notation for a variable rule takes the general form indicated in (2), with angle brackets denoting variability:

(2) $x \rightarrow \langle y \rangle$

Such a rule is read as: “*x* is realized as *y* with a certain probability.” This probability varies between zero and one, representing the overall rate of use of variant *y*. Abstracted away from any contextual conditions, it is customarily represented as p_0 , the “input probability.” In this formalism, language change is represented as changes in the value of p_0 . An alternant that becomes more common has an increasing probability of occurrence over time, while one that is becoming less common has a decreasing probability. A “completed” change, with a categorical outcome, is represented by a probability for some alternant that reaches 1, while all others go to zero.

2.1 Conditions on change

Many sound changes are, of course, conditioned. How is conditioning treated in a variationist approach? It follows quite naturally from the observation that for most – perhaps all – linguistic variables, the several variants are not uniformly distributed across linguistic contexts; rather their distribution is “lumpy”

– some environments favor one variant over others. Thus the tensed and raised variants of English /æ/ mentioned above are most frequently found before tautosyllabic nasals (e.g., *man*, *ham*), but less common before stops (*cat*, *rag*). Furthermore, in addition to the linguistic contexts that we are accustomed to thinking of as conditions on sound change, we should realize that social “contexts” are normally also involved, such that certain speakers or social groups, and certain speech styles, discourse types, or social settings, will also tend to favor one variant over another. This is another aspect of the orderly heterogeneity of language: systematically, certain alternants occur at a predictable frequency in certain contexts.

It is clear that these conditions, both linguistic and social, may also have variable rather than categorical effects. In other words, it is often the case that a particular context raises or lowers the frequency of use of a variant, rather than categorically requiring or prohibiting it. Categorical contexts *are* encountered, just as they are found in historical studies of particular languages: for example, the synchronically variable process in Brazilian Portuguese involving the denasalization of vowels appears to be categorically blocked in stressed syllables (Guy 1981). But many contexts are not categorical: thus the same denasalization process is favored by a preceding palatal segment, and disfavored by a preceding nasal, but neither of these contexts has a categorical effect. Rather, compared to a mean rate of about 67 percent denasalization, a preceding palatal is associated with a raised denasalization rate of 85 percent, and a preceding nasal with a lowered rate of 46 percent.

How are contextual effects represented in the variable rule formalism? Variable conditioning environments are also indicated in the rule notation by angle brackets, as in (3), and each is associated with a conditional probability or “factor weight,” customarily denoted by p_i , p_j , p_k . . . for factors i , j , k . . . High p_i values (approaching 1.0) indicate factors that strongly favor selection of some variant, while low values (approaching 0.0) indicate a disfavoring context. Categorical constraints, which obligatorily require or absolutely prohibit a given outcome, are also subsumed in this formalism, receiving the extreme values of 1 or 0:

$$(3) \quad x \rightarrow \langle y \rangle / \langle i \rangle \text{ ____ } \langle j \rangle$$

To predict the actual frequency of use of some variant in a given context requires a mathematical model of how the various constraint effects combine with p_0 . The preferred function for this is a logistic equation (Rousseau and Sankoff 1978), which, for contextual constraints i , j and input p_0 , predicts a frequency of occurrence f as follows:

$$(4) \quad \frac{f}{1-f} = \frac{p_0}{1-p_0} \times \frac{p_i}{1-p_i} \times \frac{p_j}{1-p_j} \dots$$

Where do the values of the constraints come from? Like categorical constraints, many of these appear to be quite general, evidently based on general

or universal characteristics of linguistic structure and organization, while others are language- or dialect-specific.² The Portuguese denasalization example mentioned above illustrates this point: the categorical stress constraint is consistent with a very general, possibly universal, pattern: syllabic stress gives greater prominence to the features of a syllable, and favours their retention. Cross-linguistically, many languages have shown historical changes involving reduction or deletion in unstressed syllables, which were blocked in stressed syllables. Similarly, for the variable constraint effect of a preceding nasal, it is a very general observation that a nasal segment is commonly associated with nasality in other adjacent segments. Indeed, Portuguese acquired its nasal vowels in the first place by a historical change involving nasal spreading from consonants to adjacent vowels. So these constraints illustrate the point that variable processes are governed by the same kinds of general or universal tendencies that have been found to be operative in the historical changes that have been construed as categorical.

This is also true of language-specific constraints. For example, English has a variable deletion of final coronal stops which is conditioned by following context. This process appears to be diachronically stable in English, but it resembles historical changes in a number of other languages (e.g., Latin and French). In running speech, coronal stop deletion (CSD) is favored by a following obstruent and disfavored by a following vowel (compare *wes' side* and *west end*). This condition has analogues in historical changes in other languages (e.g., those that gave rise to liaison phenomena and other final segment alternations in French), and is readily explained as deriving from essentially universal preferences in syllable structure. But the effect of following approximants is not so universally explicable. A following /l/ favors a high rate of deletion, while a following /r/ approaches the vowels in disfavoring deletion. Why should this be the case? Assuming that deletion is blocked when the coronal stop is resyllabified rightward in running speech, these results are explained by the language-specific prohibition on tautosyllabic /tI-, dI-/ sequences in English. No attachment to the onset of a following syllable beginning with /l/ is possible, so no blocking of deletion occurs in that context, whereas attachment and blocking are possible with /r/ (compare *act like* with *act real*).

Conditions on phonological variation therefore show the same patterns and explanations that have been found for conditions on sound change. In each case, some are universal and some language-specific, but all are consistent with the grammar of the language. In variation studies, this observation has prompted the hypothesis that the constraint effects – the values of p_i – are part of the grammar. For speakers having the same or substantially similar values for a set of constraint effects we can identify a shared grammar, *even though these speakers may differ substantially in overall rate of use of a variable*, that is, in the value of p_0 . Thus all English speakers treat following /l/ as a favorable context for CSD, even though some of them may have overall deletion rates of only 5–10 percent, while others have deletion rates as high as 60–70 percent.

The consistency of constraint effects across speakers within a speech-community has been empirically demonstrated in many studies of variation and change. Guy (1980) shows that individual deviations from the community norm are within the bounds of statistical fluctuation and sampling error, and that as more data become available, individuals become more and more consistent in their constraint effects. Sankoff and Labov (1979) show that the linguistic constraints on variation are highly stable across various social subgroupings of a community of speakers. Therefore, it is normally assumed in variation studies that membership in a speech-community implies sharing much of a common grammar, including shared constraint effects on variation and change. Significant differences in constraint effects imply that the speakers have different grammars, and belong to different speech-communities, but significant differences in the rates of use of a variable do not carry this implication.

Consequently, variation within one speech-community will in an important sense consist primarily of fluctuations in the value of p_0 . Some speakers may be high users or low users of a variant, but all members of a speech-community should have essentially the same constraint effects. By extension, in diachronic change, we would make an important distinction between differences in the value of p_0 (which simply indicates that some speakers, and some points in time, are more conservative, while others are more advanced in a change), and differences in the constraint effects, which would imply a restructuring of the grammar.³ Empirically, what we find is that the former case is much more common; p_0 changes while the values of p_i remain stable.

2.2 *Modeling social conditions*

Social conditions on variation and change may, for convenience, be represented in the way we have just described for linguistic conditions. Thus many published studies represent each social group investigated as another context associated with a constraint effect, and favoring and disfavoring social classes or generations will be identified quantitatively by comparing their calculated factor weights. However, there has been extensive debate in the literature on variation and change over the theoretical status of such a treatment. One issue is that social constraints are not as independent of one another as are linguistic constraints. In the Portuguese denasalization example, stress and preceding segment are perfectly independent dimensions: both stressed and unstressed nasal vowels occur with all possible preceding segments, and there is no theoretical or empirical evidence to suggest any statistical interaction between them. But social dimensions like gender and socioeconomic status are not so independent: in a society with patriarchal characteristics, gender is a partial predictor of status, income, and occupational prospects, so an analysis that treats these as if they were independent and non-interacting conditions is statistically and theoretically flawed.

Another concern is subtler, bearing on how we conceptualize the relationship between our dependent and independent variables. One might readily view linguistic constraints as forces acting on a linguistic variable, like winds blowing a leaf around the yard. But one is not so ready to view people as social atoms buffeted by independent social abstractions like class and gender. Rather, prevailing social theory treats class and gender as socially constructed from the interactions of individuals – the “practice” of the community. Thus the use of a denasalized vowel in Brazilian Portuguese contributes to constructing the speaker’s class and gender identity, but it does not, in any comparable sense, “construct” the preceding segment as palatal, or the metrical status of the vowel as unstressed.

For several reasons, therefore, it is preferable in analysis and/or interpretation to distinguish social and linguistic conditions on variation and change. A more socially realistic model would be to see each individual in a speech-community as having a characteristic value of p_0 which is determined in part by his or her social experience and in part by his or her interactive goals, the identity that the individual is seeking to construct. We expect, on both theoretical and empirical grounds, that socially similar individuals will have similar rates of use of a variable, similar values of p_0 . But pooling these similar individuals and deriving group values that characterize, say, working-class speakers or speakers belonging to the baby-boom generation is a way of generalizing that is done more for practical convenience than for theoretical merit.

Modeling issues aside, however, it should be clear that including the social dimension has important benefits for our understanding of language change. It has long been recognized in historical linguistics that the structures and processes of language are not sufficient by themselves to explain and predict sound change. Answers to the social questions of who initiates and leads linguistic innovation, and what social, stylistic, and attitudinal factors influence the direction of change, are essential for a deeper understanding of linguistic history; they also allow us to make contributions to social theory. The nature of the “social conditioning” of variation and change will be explored further in section 3.

3 Phonetic versus Phonological Change

The model of change sketched above bears an obvious relationship to the Neogrammarian model of sound change (cf. Paul 1891). Since the structuralists, linguistics has emphasized the distinction between mere shifts in phonetic value, and changes that affect the structural organization of the phonology. Truly *phonological* change is therefore often seen as consisting of structural reanalysis, possibly occurring in the course of language acquisition. In this view, the speakers of some new generation construe the input they receive differently, and therefore construct a new mental grammar which is discretely

different from that of their parents. Hence while phonetic change may be gradual, phonological change is seen as qualitative and essentially instantaneous. How is the variationist approach relevant to this issue?

This question leads us into a thicket of additional questions. Are we attempting to characterize the grammar of individuals or the usage of the speech-community and the grammar of the language as a whole? What models of grammar should we use? What are the appropriate levels of representation in our analysis? Is variation best described as the output of a single grammar with variable elements, or in terms of a mixture of outputs of several discretely different grammars? A full treatment of such issues is beyond the scope of the present chapter, though some are touched on in this and later sections. For the moment we may note that some such questions may turn out to address nothing more than notational preferences, while others, insofar as they deal with unobservable features of the mental grammar, may be unresolvable. But in the main I will argue that, where empirical evidence bearing on change at the structural, phonological level is available, it suggests this is also analyzable in terms of a variationist model.

3.1 *Inherent variability in phonology*

At the first level of analysis, the opposition between phonetic and phonological change may be cast in terms of the distinction sketched above between changes in the overall rates of use of a variant and changes in the rankings of the contextual effects that condition it (i.e., changes in p_0 as opposed to changes in p_i, p_j, \dots). The latter would indicate a structural, phonological change, while the former would, as noted above, be treated as outputs of a common grammar. But it is also worthwhile to apply a variationist perspective to the whole conceptual dichotomy that opposes phonetic (allophonic, subphonemic) change to phonological (phonemic, structural) change. These are ordinarily conceived of as discretely opposed categories of change. Thinking in variationist terms, we may find it more useful to interpret them as end-points on a continuum. Although the end-point of a change may represent a qualitative shift from the variable to the categorical, it can also be seen as a quantitative shift from, say, 99 percent use of a variant to 100 percent, which is identical in magnitude to the shift from 50 percent to 51 percent.

Several lines of evidence suggest such a reinterpretation. First, there is a body of research bearing on the topic of "near mergers," in which two phonemes become phonetically almost but not completely indistinguishable, and may subsequently separate (see Labov 1994: chs 12–13 for an extended discussion). Labov et al. (1972) describe the case of the *fool* and *full* word-classes in the Southwestern US: native speakers cannot reliably distinguish them in perception, but their productions, while acoustically very close, are nonetheless distinct. This suggests that a presumably gradual and variable quantitative approximation has brought two discrete underlying representations asymptotically close, without

quite achieving full merger. When such phonemes subsequently separate in phonetic space, as occurred historically, for example, with the *meat* and *mate* word-classes in English in the sixteenth and seventeenth centuries, some words turn out to have changed class membership, suggesting that during the period of close approximation, they were so close phonetically to the other class as to be reinterpreted phonemically.

Such results imply that the “discrete” change of merger can be interpreted as merely one incremental quantitative step beyond the phonetic change that leads to near merger. Furthermore, the boundary between near and full merger is subject to variability: some words may cross the line while others maintain their class membership. Yes, the end-points of a change may exhibit discrete differences: at one point in the past Romance speakers in Iberia had a distinct, phonemic contrast between short /i/ and long /e/, while today these are indistinguishable, and there is no basis for supposing that any modern speaker of Spanish or Portuguese has any way of distinguishing which items in the merged modern word-class came from which of these Latin sources. Hence over the long term the change went from complete distinction to complete identity. But the historical reality was probably much more continuous, involving a drifting range of variation in the community and in the speech of individuals. Before arriving at the complete merger, it is likely that the community of speakers passed through a stage of near merger, where the two sounds were, for some speakers and some purposes, both distinct and identical, at the same point in time.

Second, there is ample evidence from variation studies that underlying representations are not necessarily unique and uniform: some forms for some speakers can have multiple underlying representations. This is inferred from numerous cases of lexical exceptions to variable processes. In the English CSD case, for example, the lexical items *and* and *just* are found in deleted forms significantly more often than can be explained by their phonological shape or contexts of occurrence. To explain surface instances with the final /t/ or /d/, we must postulate an underlying form containing a final stop. But one straightforward account of the high rate of final coronal stop absence in these words is in terms of additional underlying representations like *an'*, *jus'*, without final stops. A parallel case is the exceptionally high rate of deletion of final /s/ in the word *entonces* ‘then’ in several American dialects of Spanish (e.g., Puerto Rican, Argentine), which is most easily accounted for by postulating an additional underlying lexical entry without a final /s/. If we generalize from these cases to the point in a change when “phonological” restructuring is occurring, we must allow for the possibility that speakers could simultaneously entertain underlying representations reflecting both the old and the new structures.

Finally, there is evidence indicating that underlying mental representations may vary across the speech-community, and during the course of a speaker’s lifetime.⁴ For example, Guy and Boyd (1990) argue that significant differences in CSD rates in the English morphological class of “semi-weak” past tense verbs (*told*, *kept*, *lost*, etc.) are due to differing morphological analyses of these

Table 8.1 Coronal stop deletion in semi-weak past tense forms: distribution of speakers by age and deletion rate

Deletion rate (p_i) in semi-weak verbs	Age of speaker		
	0–18	19–44	45+
High ($> .75$)	7	0	0
Medium ($.75 > p_i > .60$)	1	9	4
Low ($< .60$)	0	3	10

Note: Chi-square = 40.83, $p < .001$

Source: Guy and Boyd 1990: 10

forms in speakers' mental grammars. The results, illustrated in table 8.1 (adapted from Guy and Boyd's table 3), suggest an age-graded reanalysis of this class.

In early childhood, virtually all speakers appear to interpret these forms as ordinary strong verbs lacking final stops, and hence have very high rates of stop absence in such forms, significantly higher than in any other morphological class. In adolescence, there is a systematic progression in the population to more moderate rates of final stop absence in such words (a conditional probability between .6 and .75), implying a new mental analysis in which they form a discrete class, distinct from ordinary strong verbs and including a final stop in the underlying representation. At this point these final stops are deleted at approximately the same rate as those in monomorphemic (underived) words like *bold* and *cost*, which had a p_i of .65 in this population. This suggests that this age group accords these forms a holistic mental representation which does not treat the final stops as separate morphemes. Finally, for some but not all adult speakers, another reanalysis occurs, in which the final stop in such words is identified as an affix, related to the *-ed* suffix in regular weak verbs; as a result, the deletion rate in such words falls to a level significantly lower than that of monomorphemic words, and begins to approach the low rate found in words like *bowled* and *tossed*.

It should be emphasized in considering this age distribution that this situation appears to be diachronically stable in modern English. Although in some circumstances inter-generational differences in the use of a variant are indicators of a change in progress (see section 4.1 below), there is no suggestion of that here. Overall rates of use of CSD are flat across the generations, as are other constraint effects. It is only the deletion rate in one morphological class of words that is involved here, not the value of p_0 , and no real-time evidence or other social factors indicate change in the community as a whole. Rather, this appears to be a purely ontogenetic development, which every speaker in the community can be expected to pass through in the course of her or his lifetime.

These findings of near mergers, lexical exceptions, and acquisitional reanalyses imply that within a speech-community which in most respects is perceived as grammatically unified, variation in underlying representations may occur. At a given point in time, not everyone will entertain the same mental grammar, and individual speakers will alter their different mental grammars in the course of language acquisition and maturation. Change at the phonological level may arise in a temporally gradual way out of a background of variability just as phonetic change does.

3.2 *The phonology of the speech community*

What do such observations imply for the grammatical unity of the speech-community? We have proposed above that variation within the community will be confined to differences in the p_0 values for variable processes, while constraint effects, along with other features of the phonology, will be consistent for all community members. But where do variation and change at the phonological level fit in to this picture?

For the most part, the cases we have considered may be treated as variation or change in underlying representations, while the phonology remains the same in other respects. In a near merger, we would normally postulate two different underlying phonemes with extremely close phonetic realizations. As the two become difficult to distinguish in perception, some lexical items for some speakers are “misspelled” (or respelled) in the mental lexicon, as it were, that is, represented as belonging to the historically “wrong” word-class. When some speakers move beyond near merger to full merger, they “spell” all the relevant words in their mental lexicon with the same phonemic representation. The only substantive change required in the rest of the phonology would be that merged speakers would no longer construct two different sets of phonetic realization rules for the words that now fall into just a single class. Similarly, in the lexical exception cases, we have proposed that multiple underlying lexical representations exist for some words and some speakers; otherwise, the rest of the phonology should remain identical. Finally, the Guy and Boyd example of change in acquisition also deals with underlying forms: speakers at different stages in this process do not differ in either their p_0 or p_i values for the variable rule of CSD; rather, they have different underlying representations for one small set of words.

Under these analyses, phonological variation and change might be seen as primarily lexical. This is a happy result: differences in lexicon are both ubiquitous and grammatically trivial. It is likely that no two speakers ever have identical lexical inventories, but this does not prevent us from saying that many speakers share a dialect or a phonology. So insofar as phonological change emerges from variation in lexical entries, it does not pose any new problems to our model.

However, this analysis will not account for changes in constraint effects; if some constraint that once inhibited a process later is found to promote it, it

seems unlikely that an explanation can be found in lexical variability. Unfortunately there are few studies of sound changes in progress that allow us to empirically investigate this problem (although there are some studies of syntactic change⁵). However, it presumably occurs, given dialectological evidence of opposed effects. A classic example is the effect of following pause on English coronal stop deletion: in some North American dialects (e.g., New York City English and African-American Vernacular English), pause promotes deletion, while in most others (e.g., Philadelphia, California) it inhibits CSD (Guy 1980). If these dialects all diverged from a common ancestor by spontaneous change processes, one or the other set must have undergone a change where this constraint changed its value. But other explanations are also possible that do not involve spontaneous reversal of constraint effects. The difference might have social origins in the different sociolinguistic histories of the dialects, arising, for example, from contact-induced changes. Alternatively, one might seek an explanation in other aspects of the phonology (e.g., perhaps the default phonetic realization of pre-pausal stops differs in these communities, being released in the retaining dialects and unreleased in the deleting dialects). Unfortunately none of these dialects is currently changing this variable, so further empirical investigation will not offer a resolution.

More drastic reorganizations of the phonology may also remain unaccounted for in this model. Consider, for example, the metrical change in European Portuguese since the sixteenth century and its far-reaching consequences. Generally speaking, the language has changed from a syllable-timing to a stress-timing system; accompanying this, there have occurred segmental changes such as reductions of unstressed vowels to schwa, deletions of unstressed segments and syllables; syllable structure changes such as the development of new codas and consonant clusters; and phonotactic changes such as alterations in the inventory of segments permissible in various locations. It is not clear whether such a complex set of developments would be modelable in terms of changes in p_0 of assorted sociolinguistic variables together with alterations of some lexical representations, or whether other theoretical constructs (e.g., resetting of parameters? OT-style constraint rerankings?) would be required. Resolution of such issues may have to await the discovery of a comparable change in progress.

3.3 *Variation, change, and optimality*

Any discussion of constraint effects in phonology written after the early 1990s must make an obligatory reference to Optimality Theory (Prince and Smolensky 1993). As readers will be aware, OT is a completely constraint-based model that attributes all phonological differences between language varieties to differences in the rankings of a universal inventory of constraints. Therefore in this theory diachronic changes and synchronic phenomena like dialectal differences and sociolinguistic variation within dialects are all represented in

terms of a single mechanism. Change is simply constraint reranking over the long term, while synchronic variation is constraint reranking in the short term. Since the constraints are universal, one cannot, presumably, contemplate an actual reversal of the effect of a given constraint, but devices like parameterization of constraints, and constraints that produce contradictory effects, make it possible to generate the same kind of results.

In some respects this is an attractive theoretical program, yielding some of the unified views of variation and change that I have argued for above. However, the principal deficiency of the OT model, compared with the analysis presented here, is its inability to express the steady quantitative rise of the rate of use of an innovation, quite apart from any change in constraint effects. In other words, there is no p_0 in OT. For the Japanese change mentioned above, for example, an OT analysis might have one constraint order that declares / η / to be the optimal output and another that picks / g /, and hence could capture the end-points of the change in terms of a replacement of one order by the other. But the model has no mechanism for representing how the new order slowly and steadily becomes more and more frequently selected over a period of several generations. Furthermore, since constraint rerankings can produce chaotic results, because the effect of a given constraint on the output may abruptly disappear if it is eclipsed by some higher-ranked constraint, it is not clear that an OT model would be able to correctly capture the stability of constraint effects (the $p_i, p_j \dots$ values in the variationist model) that are observed in empirical studies during the course of a change (see section 2.1, section 5.4). In general, the OT model leads to predictions about variation and change that are incorrect (Guy 1997b).

4 The Social Distribution of Change in Progress

Studies of change in progress in a number of speech communities suggest a common thread of patterns in the distribution of linguistic innovations across the social fabric. Unsurprisingly, not all speakers adopt and extend new forms of speech at the same rate. Rather, some lead and some lag, and the leaders turn out to be characterizable in fairly regular ways along the major social dimensions of age, sex, and social class. This characterization should be qualified in two respects, however. First, the majority of extant studies of change in progress have examined Western societies, mainly in advanced industrial economies. Investigations of changes in progress using a variationist methodology have been done in Asia, Africa, and Latin America (e.g., *inter alia*, Hibiya 1988; Haeri 1997; Cedergren 1973; Tarallo 1996), but these parts of the world have been underrepresented in the development of the accepted wisdom described here. In societies that had a social organization substantially different from those on which these findings are based, different patterns of innovation might be expected. Second, it is generally recognized that there are several different sociolinguistic types of change, which differ in some respects in their social

distribution. The most basic distinction is between untargeted, “spontaneous” changes, developing within the speech-community, and changes arising from language or dialect contact (e.g., “borrowing”), involving input from outside the changing speech-community. Other factors in this typological distinction include social awareness of the change (Labov 1966), and in contact situations, the native language of the speakers who are the agents of change (van Coetsem 1988). A fuller treatment of these issues may be found in Guy (1990); some of my discussion here will be limited to spontaneous changes.

It must also be emphasized that the group differences to be discussed here are systematically quantitative and not qualitative. Rarely in the study of variation and change does one encounter a categorical difference between social classes or age cohorts or gender groups, where one group always uses variant *x* while the other uses variant *y*. Instead one finds differences of more and less: the leading group uses more of a variant and the lagging group less.

4.1 Age

The most systematic feature of the social distribution of changes in progress is that linguistic innovations are most advanced among younger generations. In ongoing changes, the leading edge is regularly found in the young adults and older teenagers in a speech community. While perhaps unsurprising, this is not a logical necessity. One might imagine that the entire community changes together at the same rate, so that at any given point in time all the generations use equal amounts. Alternatively, the socially dominant and powerful generations – the middle and older age groups – might lead, setting standards that others emulate. But empirically, what we find is that a plot of rate of use of the innovation by speaker’s year of birth regularly shows an increase with each successive age cohort – the so-called “s-shaped curve.” When data on the youngest members of a speech-community are available, there are usually downward perturbations of the trend during childhood and early adolescence, due presumably to the conservative influence of parental speech, so peak rates of usage of the innovative forms may be said to occur among the youngest generation to have achieved “linguistic majority.”

A typical example of this pattern is found in figure 8.1, reproduced from Hibiya’s (1996) study of denasalization of the velar nasal stop in Tokyo Japanese. (This figure is plotted with age increasing to the right so the curve is more “z-shaped.” Ages are plotted as of 1986, when the main corpus was collected.) Within each cohort there is variability, but the overall trend clearly shows the change from nearly categorical use of [ŋ] among speakers born before 1900 toward extremely high use of [g] among older teens and young adults (speakers born after 1966).

The pattern illustrated in the under-80 portion of figure 8.1 shows the distribution of a change in “apparent time.” Although such data actually constitute a synchronic snapshot of a single point in time, the progress of the change is

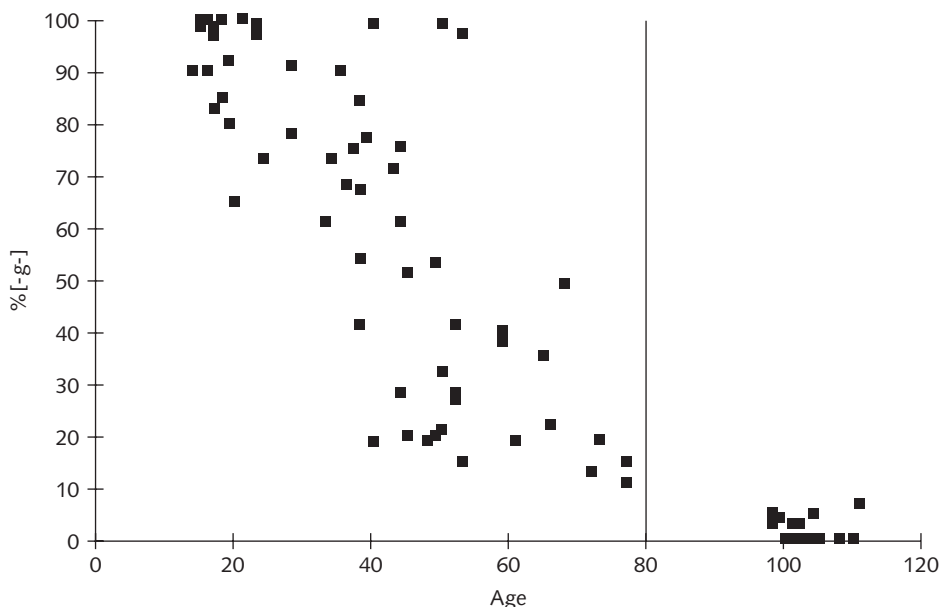

Figure 8.1 Age distribution of [-g-] in Tokyo Japanese

Source: Hibiya (1996: 163)

reflected in the differential use by age. The presumed explanation for such findings is that speakers, upon achieving linguistic majority, stabilize their linguistic system and are (at least relatively) resistant to further innovation. Although the newest cohort stabilizes at a point further along the track of the change than their predecessors, they are immediately supplanted as the most advanced by the next, which carries the change a little further still. Hence the age groups available to us for study are laid down in the community like geological strata, each one illustrating the usage of the young adults of some time in the past. The 40-year-olds of today give us information about how 20-year-olds were talking 20 years ago, and the 60-somethings of today tell us how 20-somethings were talking 40 years ago.

How accurately does this apparent time picture represent the “real-time” course of the change? A number of studies have investigated this question comparing data collected from different times (e.g., Cedergren 1984; Guy et al. 1986; Labov 1994; Thibault and Vincent 1990). The results largely verify the model sketched above. Hibiya’s study provides an illustration of a real-time comparison. In figure 8.1, the data on speakers born in the nineteenth century (those to the right of the vertical line) are drawn from recordings made in the 1940s and 1950s with persons who were then between 60 and 80 years of age. If plotted by their age at the time of recording, these speakers would be anomalously low. But plotted by year of birth, they are consistent with a smooth projection of the trend backward into the nineteenth century.

One study supplying robust correlations between real and apparent time data is Bailey et al. (1991). This paper compares the age distribution of a number of sociolinguistic variables in Texas English in data collected in 1989 with other data collected 15 years earlier. The study investigates 11 phonological variables, including the /ɑ/-/ɔ/ merger, the merger of tense and lax vowels before /l/, the loss of [j] from /ju/ diphthongs after alveolars, and the fronting of the nucleus of the /au/ diphthong.⁶ The authors of the study conclude (p. 241) that “whenever apparent time data clearly suggest change in progress . . . , the [earlier] data show substantially fewer innovative forms,” which is consistent with an expansion of usage of the innovations in the 15 years separating the two samples. By contrast, when the apparent time distribution is flat across the age groups, suggesting stable variation, the earlier data are “virtually identical” to the more recent sample.

4.2 *Class*

How to characterize the distribution of changes in progress across social classes has been the subject of considerable debate in the literature on language variation and change. Labov, in a series of works based on data from a number of studies (Labov 1966, 1972a, 1980b, 1990), has identified what he terms “the curvilinear pattern,” in which innovations are most advanced among speakers toward the middle of the socioeconomic scale – roughly speaking, the upper working class and the lower middle class – while speakers at both the top and the bottom of the scale tend to be more linguistically conservative. An example from Labov’s work (1980b: 261) is found in figure 8.2, dealing with the changes in Philadelphia English involving the fronting (and raising) of the nuclei of the diphthongs (aw) (top graph) and (ey) in closed syllables (eyC – bottom graph). In each case the vertical axis is the coefficient for class (in Hz) from a regression analysis of F2 measurements of 93 speakers. The socioeconomic class scale is based on a 16-point index combining education, occupation, and residence value, with 0 representing the lowest class, 6–9 representing what might be termed the upper working class, and 16 the upper class.

The graphs in figure 8.2 show a significant lead toward the use of more advanced, fronter articulations of these changing vowels for speakers in the middle of the scale, with a peak in the upper working class. From this peak, there is a drop-off toward less fronted variants at both the highest and lowest end of the social spectrum.

For Labov, the curvilinear pattern is an empirical finding. He suggests an explanation for it in terms of a positive motivation for change tied to “local identity,” which is presumed to be highest among social groups who are strongly rooted in the local community. This suggestion is justified by Labov’s neighborhood studies in Philadelphia, which have examined in some detail the personal networks of leading and lagging speakers. It is also consistent with the general observation that local ties appear to be weaker among many

Image Not Available

Figure 8.2 Fronting of (aw) and (eyC) in Philadelphia: regression coefficients for socioeconomic classes

Source: Labov (1980b: 261)

individuals of both the highest status (e.g., the “jet-set”) and the lowest status (e.g., the homeless).

An alternative view has been proposed by Kroch (1978), who cites other studies of change in progress in which there is no evidence of lower rates of use by the lowest-status groups. Kroch advances an alternative “linear” model, in which rate of use of innovations is simply an inverse function of status: the upper class uses the least and the lower class uses the most. In Kroch’s view, what requires a social motivation is not change, which is presumably the

Image Not Available

Figure 8.3 Class distribution of high-rising intonation in declaratives in Australian English

Source: Guy et al. (1986)

natural state of language since it is observed historically in all languages at all times, but rather resistance to change. Why should some speakers resist an innovation that is spreading in their community? Kroch sees the answer in the social and linguistic conservatism of dominant social classes. The dominant groups have the social power to impose their class dialect as the standard variety of the language, and hence have a motive for resisting innovations, which are potentially threatening to their position. The ideology of linguistic "correctness," of a "standard" dialect defined by authority and history (and of course by the social position of its users), is an overt manifestation of this conservatism. Hence, higher-status speakers exhibit more resistance, and lower-status speakers less resistance to linguistic innovations.

How may these models be reconciled? On the question of motivation they are not incompatible. It is surely plausible that in one community there might be present at the same time groups with positive motivations to innovate, and others with negative motivations who resist innovation. The empirical questions may also prove to be compatible, with further analysis. For example, Guy et al. (1986) find both the linear and curvilinear patterns present in the spread of a high-rising terminal intonation in declaratives in Australian English. As figure 8.3 demonstrates, this change in progress has male speakers showing the pattern identified by Labov, while female speakers illustrate Kroch's pattern. This raises the possibility that some interaction of class and gender is involved in producing the difference, a point that has been further addressed in Labov (1990).

One synthesis of these two accounts of the class distribution of innovations is obvious. Both agree on what happens in the upper portion of the class

or status scale: roughly speaking, from the working class upward there is a decline in the rate of use of new forms. The upper and upper-middle classes have never been found to lead a spontaneous sound change (i.e., untargeted, uninfluenced by language or dialect contact) in any modern study of a change in progress. This contradicts one traditional hypothesis about social motivations of change, the so-called “flight of the elite,” which supposed that elite groups innovate to distance themselves from their social “inferiors.” In the modern world, there is no evidence for such a process in spontaneous change. Changes in which higher-status speakers have been found to take a leading role all appear to involve the importation of an external prestige norm, a borrowing type of change – for example, the reintroduction of post-vocalic /r/ in New York City as a prestige feature (Labov 1966).

4.3 Sex

The effect of biological sex or socially constructed gender on language change is a topic that suffers from a dearth of empirical systematicity and a surfeit of theoretical explanation. In a sizable majority of published studies, female speakers are found to use innovative forms more, on average, than males of a comparable age and social class. But this generalization is weaker than the previous two: there are clear cases where men are in the lead, and others where no gender differentiation is apparent.

The present volume is not the place to attempt a thorough exegesis of the various proposed explanations for these findings; instead I will offer only some illustrative examples. Interested readers may refer to works such as Eckert (1989) and Labov (1990) for more extensive treatments. One current of theoretical opinion appeals to the social construction of gender: the roles and practices which define gender identity. Thus Labov (1972a: 302) describes gender differentiation of language in terms of “an expressive posture which is socially more appropriate for one sex or the other.” Eckert (1996) is a work that explores in some ethnographic detail such expressive use of variation in the construction of gender and class identities of an adolescent population. In such a view, change is a social by-product of the complex interplay of social groups involved in defining themselves and their communities in relation to local and global linguistic markets.

Another interesting line of explanation for gender roles in language change appeals to the symbolic or iconic value of biological differences between male and female speech. As a secondary sexual characteristic, adult male and female speakers differ in vocal tract and laryngeal size. These anatomical differences produce acoustic effects, such as higher pitch and formant frequencies for female speakers. Auditorily, hearers discount these differences in speech perception, through a mental version of the process known as normalization in acoustic phonetics. Thus when a male and female from the same dialect background utter the same word, they are ordinarily perceived as saying the same vowel sounds, even though the second formant values of the female speaker may be

significantly higher than those of the male. Without this normalization, higher F2 values would otherwise signify fronter vowel articulations. If hearers retain some perceptual access to the unnormalized signal, they would be aware on some level that female speech sounds acoustically “fronter” and male speech “backer.” When a sound change is under way and phonetic targets are moving, this sexual polarization may influence speakers’ productions and/or perceptions of changes involving the front–back dimension. In a change involving fronting, women could potentially be heard as more advanced, and more advanced articulations could be perceived as more feminine.

Haeri (1996) presents a survey of 19 variable processes involving fronting or backing, and notes that with only two exceptions, males lead the backing processes while women lead the fronting processes. Hence there is a connection between the intrinsic bio-acoustic differences in speech and the “expressive” social postures adopted by the gender groups in the course of variation and change. However, Haeri also notes that this connection is complex, mediated by the social construction of gender identity, and interacting with other aspects of social structure. Class and age, for example, continue to be important correlates of the use of innovations. Biology alone is a poor candidate for explaining gender differentiation of language change.

A third approach, based on another aspect of social practice, is offered in Labov (1990). Beginning with the observation that changes must of course be communicated to new generations of language acquirers in order to survive, Labov notes that access to children may act as a social filter on the reproduction of innovations. Women in all societies have a prominent role as care-givers of children, and so may have greater influence on language acquisition. If gender-differentiated changes were initiated in a speech-community for whatever reason, the ones which were current in the speech of women would be more readily acquired by their children, while those which were predominantly associated with men would be retarded in their transmission to the next generation.

5 Theoretical Issues: A Variationist Perspective

5.1 Regular sound change and lexical diffusion

For over a century diachronic linguistics has confronted the Neogrammarian hypothesis of “regular” sound change, the claim that a sound change operates on abstract phonological units (i.e., something like the phoneme), and hence affects all instances of a phoneme, regardless of the lexical identities of the words it occurs in. This hypothesis rests on a sound evidentiary footing, but it has faced persistent counter-claims to the effect that change proceeds word by word, what has been called lexical diffusion.⁷ What can variation studies contribute to this debate?

In the main, studies of linguistic variables, including those that are involved in ongoing change and those that are diachronically stable, support the Neogrammarian position. All lexical items that include the targeted phonological unit are generally affected. When conditioning appears, it is normally readily definable in terms of phonological context (e.g., the following segment effects on CSD, the stress effect on Portuguese denasalization, the closed syllable constraint on fronting of (ey) in Philadelphia), or morphological context (e.g., the morphological class effect on CSD).⁸ The “lexical” constraints that appear are generally minimal, and like the cases mentioned above (high deletion rates in *and*, *just*, *entonces*), can usually be handled in terms of additional lexical entries for a handful of items. So variation studies are consistent with the broader picture, suggesting that variation and change in speech sounds is essentially regular.

However, some cases have turned up that are hard to reconcile with the Neogrammarian model. One of the best studied is the split of short-*a* into tense and lax variants in Philadelphia.⁹ At first glance, this split appears to be subject to simple phonological conditioning: /æ/ is tensed before front nasals and voiceless fricatives: thus *ham*, *man*, *staff*, *path*, *gas* are tense, while *hang*, *cash*, *jazz*, *sad*, and *back* are all lax. There is also a constraint requiring the conditioning consonant to be tautosyllabic: thus *hammer* is lax while *hamster* is tense. Things get a little more complicated when we discover minimal pairs like verbal forms *canning*, *manning* (tense) versus proper names *Canning*, *Manning* (lax), but this can presumably be reconciled by means of a derivational model in which the tautosyllabic constraint for tensing is satisfied in the verb roots *can*, *man* before affixation. More complicated still is the fact that the words *ran*, *swam*, and *began* are all lax, despite fulfilling the tautosyllabic front nasal constraint. Nevertheless, an advocate of phonological conditioning might postulate some morphological analysis where these strong past tense forms are blocked from tensing by some aspect of their derivational history.

However, there are further details that make this split look still more lexically arbitrary, and non-regular. The words *mad*, *bad*, *glad*, are all tense, but no other words with following /d/ or any other following stop have undergone tensing. There are some words with following /l/ that tense (*pal*, *personality*), but most do not (*algebra*, *California*). Such facts do not appear to have any simple account in terms of morphological or phonological conditions on the tensing rule. At this level, predicting which variant a word has requires reference to the lexical identity of the word. In some respects, therefore, the Philadelphia short-*a* has undergone lexical diffusion, a word-by-word, phonologically unconditioned split, which in the Neogrammarian view is impossible.

The standard Neogrammarian defense against such evidence is an appeal to dialect borrowing or mixture, but this is an unconvincing and implausible account of the facts. The nearest dialect to Philadelphia with tensing before stops is New York City, which tenses before all voiced stops. Why would Philadelphia borrow just *mad*, *bad*, *glad*, and never *sad*, or *cab*, *bag*, etc.? New York also tenses in *cash*, *bash*, but no such “borrowings” occur in Philadelphia.

Furthermore, New York clearly does *not* tense before /l/, so where does tense *pal* come from – Chicago? Finally, there are social grounds to doubt that Philadelphians would willingly borrow any features of NYC English: the dialectal characteristics of New York City have had a markedly low social status in North America for more than a century, and are still the object of derision in popular culture. Rather, the evidence suggests that Philadelphia has evolved its own inventory of tense /æ/ words; this inventory is partially predicted by a conditioned sound change, but some words appear to have been added to the tense class in a lexically arbitrary fashion.

On the basis of his studies of variation and change, Labov (1981, 1994) has proposed a resolution of the “regularity question.” He argues that regularity is typical of more concrete changes, such as those that involve a single phonetic feature in a continuous articulatory space, while lexical diffusion is typically found in more abstract changes, involving changes in multiple phonetic features, and those that are defined by relative phonetic properties (e.g., long versus short, high versus low tone) rather than absolute ones (e.g., alveolar, stop). Furthermore, the two appear to be temporally ordered: regularity prevails early in a change, while lexical diffusion may arise in later stages, after a change has been subject to morphosyntactic conditioning, and become subject to conscious awareness and social evaluation within the speech-community. This may be the point at which the variants acquire different underlying representations, which makes possible the mental “respellings” discussed in section 3.2. But Labov concludes that regular sound change and lexical diffusion are not a simple dichotomy, but polar types involving a cluster of traits, rather than categories opposed in a single dimension. Other studies have found evidence of lexical diffusion even in concrete, single-feature changes, and have demonstrated the influence of other factors on the progress of a change, such as word frequency, saliency, and etymology (Phillips 1984; Yaeger-Dror 1996). In Labov’s view, the inquiry must move beyond the question of whether the Neogrammarians were right or wrong, and turn to an investigation of “the full range of properties that determine the transition from one phonetic state to another” (1994: 543).

5.2 *Functional constraints*

I will use the term “functionalist” to refer to theories that claim that the processes of language, including the mechanisms of change, must operate so as to preserve meaning and prevent communicative ambiguity. Applied to speech sounds, this is often taken to mean that phonological variation and change should be functionally blocked from obscuring the distinctiveness of lexical items or morphological categories. Thus any process that reduces phonological information (mergers, deletions, assimilations, etc.) will have a narrow row to hoe. Sound changes should be subject to some limitation where they might cause distinct words to become homophonous, or where they might make different

Table 8.2 Coronal stop deletion in three morphological classes

Morphological class	N	% deleted
Monomorphemes (e.g., <i>mist</i>)	739	38.6
Regular past (e.g., <i>missed</i>)	157	19.1
Past participles (e.g., <i>have missed</i>)	74	17.6

Source: adapted from Guy (1996)

tenses, numbers, or other morphological distinctions appear superficially identical. Similarly, in synchronic variation, functionalism would imply that variable processes should be constrained from applying where they would produce lexical or morphological homophony, or “wipe out distinctions on the surface,” in the words of Kiparsky (1972: 197).

The question of functional constraints has been extensively investigated in studies of variation and change, with mixed results. There are numerous attested variable processes that increase homophony or threaten morphological distinctions. English CSD, for example, makes past tense regular verbs like *walked* equivalent to their present tense forms. Spanish and Portuguese *-s* deletion makes plural forms like *casas* equivalent to the corresponding singulars like *casa*. Portuguese denasalization makes plural verbs like *falam* sound the same as corresponding singular forms (*fala*). Functionalist arguments would predict that some blocking of these variable processes should be observed in such contexts.

At first glance, some of the evidence appears to be consistent with this view. A case in point is CSD, illustrated in table 8.2 (from Guy 1996). As noted in section 3.1, this process is conditioned by morphological class: past tense verbs in table 8.2 are deleted only about half as often as monomorphemic words. A functional interpretation of these facts might argue that the rule is blocked in the past tense forms because the systematic homophony that it would create between past and present forms is a threat to communication.

However, the functional argument fails to explain the behavior of the regular past participles. These bear a very low functional load; their deletion poses no threat to communication, as they are entirely redundant with the obligatorily present auxiliary verb *have* (cf. *I've miss(ed) my bus*). Hence there is no reason for them to be functionally protected; nevertheless, they are deleted at a low rate, lower but not significantly different than the deletion rate of regular past tense forms.

What, then, explains the morphological conditioning of CSD? Formal structure is the obvious alternative. Monomorphemes are underived, but the past tense and participial forms are derived, and their final stops are affixes, not part of the root morpheme. Hence the deletion rule is sensitive to – is conditioned by – morphological structure. Crucially, the past tense and participial forms are structurally identical for all regular verbs, derived at the same level,

marked by affixes of the same form. This formal identity is reflected in their identical deletion rates. The constraint on CSD exactly matches the formal facts, but does not match the functional loads.

Facts such as these have led researchers in this field (e.g., Kroch 1989a; Labov 1994; Guy 1996) to argue that the processes of variation and change are not directly constrained by functional considerations. But nonetheless, linguistic function and communicative effectiveness are maintained in the long run. Millennia of sound changes have not obliterated all morphological distinctions, or made all words homophonous. How is this possible?

The answer appears to lie in the processes of perception and acquisition. Functional considerations do not block speakers from uttering ambiguous productions, but ambiguous utterances present a perceptual problem for hearers. Sometimes it must be the case that they are misconstrued. In the English case, this would mean some past tense forms undergoing CSD would be heard as present tense. Such misconstruals will be effectively bled from the perceived corpus: a verb form heard as present tense is not seen as having any relevance to CSD in past tense forms. Therefore, since only ambiguous forms are bled, the perceived corpus will appear to language hearers to have fewer applications of a process in the environments where it creates ambiguity than in the environments where it does not; in the CSD case, this means that hearers will perceive a lower rate of deletion in *packed*, *bowled*, *missed*, than in *pact*, *bold*, *mist*. This effect will be proportional to functional load, because where redundancy reduces ambiguity, fewer bleedings from the perceived corpus by misconstrual will occur. Diachronically, this implies a constant pressure on child language learners to construct a mental grammar in the course of language acquisition that preserves information that has a high functional load. Variation data suggest that they do this not by directly constructing functional constraints on production, but by reference to formal devices such as the inhibition of CSD in affixes. Nevertheless, the normal processes of perception and acquisition will act to preserve functionality in the long run, even in the absence of production constraints.

5.3 Directionality

It is commonly asserted in historical linguistics that some kinds of change are unidirectional. The paradigm case, of course, is phonemic merger; under the Neogrammarian hypothesis, the reverse of a merger – a spontaneous unconditioned split – is impossible. But more generally, it appears that lenitions are more common than fortitions, deletions more likely than insertions, assimilations more common than dissimilations, etc. Labov et al. (1972) identify several general principles governing the direction of vocalic chain shifts: lax vowels fall, tense vowels rise, back vowels are fronted. How are such issues of directionality treated in a variationist approach?

In an approach that sees sound change as emerging from a synchronic cloud of variation, directional tendencies should be synchronically reflected in the distribution of variants and the inventory of variable processes: sociolinguistic variables and “fast speech” rules. If there are many variable processes that go in one direction but not another, and variation in the community is the raw material out of which change emerges diachronically, then the origins of the directional restrictions lie in the synchronic limits on variability.

Consider the case of deletion versus insertion. Synchronically in many communities, variable processes involving deletion of a segment are encountered: coronal stop deletion in English and a similar phenomenon in Dutch, deletion of final sibilants in New World dialects of Spanish and Portuguese, deletion of final /n/ in Caribbean Spanish and deletion of /r/ in Brazilian Portuguese, etc. By contrast, variable insertions are rare, and are usually explicable in terms of reorganization of articulatory gestures (i.e., “excrecence”): for example, final *-k* insertion after [ŋ] in some dialects of Australian English (*nothink* for *nothing*) is interpretable in terms of early termination of voicing during the articulation of the [ŋ].

Of course, looking only at synchronic variation, we might naively worry whether it is possible to tell insertion from deletion without knowing which form was historically older. Ordinarily this can be inferred from lexical specificity. If, for example, all English words ending in a consonant could be found with or without an appended coronal stop, an insertion process would be plausible. But in fact, we find that while lexical items like *cold* and *last* vary in pronunciation, lexical items like *coal* and *lass* do not – they are never encountered with an intrusive final /d/ or /t/. Therefore, the occurring final coronal stops are part of the lexicon, and the variable process is one of deletion.¹⁰ Since the same situation obtains in all the cases I have cited, the conclusion that deletions greatly outnumber insertions in synchronic variation stands.

Given such observations, we may explain the diachronic developments in terms of synchronic processes of production. The physically variable characteristics of human articulation produce a range of variant realizations in one direction from the abstract target, but not in another. This variation may be consistently reproduced across generations, as with English coronal stop deletion. But if the rate of use of the variants begins to change across time, the only possible historical outcome is one that is directionally limited.

5.4 Constant rate hypothesis

Since many changes are linguistically conditioned, what can we say about how the change spreads from context to context? One of the most significant theoretical proposals in variationist studies of change is Kroch’s (1989a) “constant rate” hypothesis (CRH), which argues that the frequency of use of an

innovative variant should show the same rate of change in all the linguistic contexts in which it occurs, both favorable and unfavorable. During the course of a change, the contexts that promote the innovation will still show higher rates of usage than those that are less favorable, but the spread between favoring and disfavoring contexts will remain the same. One context will not zoom ahead more rapidly, leaving the conservative contexts farther and farther behind. As a change approaches completion, the hypothesis predicts that it will not become obligatory in one context while still variable in another. Although Kroch's original work was based primarily on studies of syntactic change, the CRH is equally relevant to phonological change.

The principal alternative to the CRH is a model in which changes originate and advance most rapidly in the most favorable contexts, and diffuse from these to less favorable environments, which lag behind. This model would also allow a change to reach completion (become categorical) in different contexts at different times. Various proposals along these lines have been made. Bailey (1973), for example, suggests just such a variable rate model for sound change, beginning and proceeding at faster rates in favorable contexts; his model also allows for contextual "reweightings" during the course of a change, which would cause them to speed up or slow down. Another such model is advanced by Naro and Lemle (1976) for syntactic change: they argue that changes begin in the most favorable contexts – in their model, the contexts where the innovation is least salient – and then "diffuse" by a kind of analogical extension into less favorable (more salient) contexts, each of which can potentially proceed at a different rate of change.

The problem that arises with models that allow differential rates of change is that they essentially treat each context as a separate process, a separate rule. If some contexts go fast and some slow, some start at one point in time and some at another, how can we speak of a single change? What prevents some contexts from not changing at all, or favoring an entirely different variant? If this occurred, it would cause phonological splits on a massive scale. Obviously, splits are attested historically, but there are many cases where sound shifts occur without splits, and such cases would be difficult to explain if, as it were, every context has its own history.

Thus the contrast here is between an approach that treats specific alterations of phonological units as a single phenomenon subject to contextual conditioning, and an approach that treats each unit-in-context as a separate entity, undergoing (or not undergoing) a separate change. Is, for example, the English /æ/-Tensing referred to above one change that happens to be promoted by following nasals and retarded by following stops, or is it a flock of separate changes, one for sequences of /æɪn/, another for /æɪm/, another for /æɪt/, etc.? If the latter, is it mere coincidence that all of this flock are flying in the same direction in several English dialects? The conventional view, well grounded in empirical evidence as well as linguistic theory, is that phonemes, and the changes that operate on them, constitute coherent units, and the CRH is consistent with this approach.

The CRH also turns out to be a necessary diachronic consequence of the variable rule model sketched above. As we have noted, a sound unit undergoing change is always subject to variation during the course of the change, and hence what is changing in the variable process is the value of p_0 , the overall probability of use of the target variant. The various conditioning factors should have a constant effect across time (at least insofar as they are defined by general or universal structural properties of language), which means in our model that the values of p_i , p_j , etc. should be stable during a change. If p_0 is the only term in the equation that is changing, and it is the same for all contexts, then the rate of change is necessarily constant across contexts.

Empirical confirmation of the CRH has been extensive and compelling for syntactic change, where evidence of variability across a long timespan is more accessible in the historical record (e.g., Kroch 1989a; Santorini 1993; Pintzuk 1995). In studies of sound change, with more limited real time depths, explicit investigation of the rate of change in different contexts has not been a high priority. However, there is ample evidence of the stability of many constraint effects on sound change across dialects and languages, and across time. For example, contexts that have a phonetic lengthening effect (e.g., following nasals, open syllables) systematically favor vocalic changes toward more peripheral positions, while shortening contexts (e.g., following stops, closed syllables), will hinder peripheralizing changes and favor centralizing changes (cf. Yaeger-Dror 1996; Labov et al. 1972). Hence it is not surprising to find that in, for instance, the Northern Cities Chain Shift, speakers at all stages of the change of /æh/ show prenasal tokens to be at the leading edge, somewhat frontier and higher than /æh/ tokens in other contexts (Labov et al. 1972; Labov 1994).

Another clear example of constraint stability is found in Fowler's (1986) replication of Labov's (1966) study of post-vocalic /r/ use in New York City. Labov had concluded that use of constricted /r/ (as opposed to a vocalized or "r-less" pronunciation) was advancing in New York, and found linguistic conditioning by word position: there was more use of constricted /r/ in word-final than word-internal position. Fowler's data, collected some 20 years later, showed that the overall rate of use of constricted /r/ had indeed increased, while the still-evident position effect was virtually identical in magnitude and direction to what had been observed in the earlier study. To recast Fowler's results in variable rule terminology, the overall probability of use of constricted /r/ had increased, while the contextual probability of internal and final positions had remained unchanged, as the CRH predicts.

The CRH deals with contexts that are all allowing the change: some may hinder it, but none prohibits it entirely. How then do we account for conditioned changes in the traditional categorical sense, which lead to splits, where one context undergoes the change completely and the other not at all? In the variable rule model sketched above (section 2.1), this is accomplished by assigning a factor weight of zero to the prohibiting environment. An inspection of the logistic equation (item (4) above) will show that, when any factor in the environment of a change has a probability of zero, the model predicts zero

use of the innovation, regardless of p_0 or any other factors present. Therefore, mathematically speaking, conditioned splits are included in the model and do not contradict the CRH.

6 Conclusions

Since Saussure, the division of linguistic studies into synchronic and diachronic aspects has been traditional. In Saussure's words: "The opposition between the two points of view – the synchronic and the diachronic – is *absolute and admits no compromise*" (Harris 1983: 83; my italics). The main stream of theoretical development in synchronic linguistics has generally embraced this position, and largely ignored the problem of change. Historical linguistics has been less inhibited by the Saussurean dichotomy, and has a long tradition of incorporating insights from synchronic theory, but this ecumenical approach is rarely reciprocated.

The basic rationale for Saussure's position is that the speaker knows nothing of language history, as can be seen in another quotation from the *Cours*: "The first thing which strikes one on studying linguistic facts is that *the language user is unaware of their succession in time*: he is dealing with a state. Hence the linguist who wishes to understand this state must rule out of consideration everything which brought that state about, and *pay no attention to diachrony*" (ibid., p.81; my italics). To some extent, this is true: clearly, modern English speakers know nothing about Grimm's law, and it is highly unlikely that they will be able to reconstruct Old English umlaut and front vowel unrounding on the evidence of the *foot–feet*, *mouse–mice* alternations. But variation studies offer two ripostes to the Saussurean position.

First, the language user *does* know something about change: ongoing changes are written across the face of the speech-community, in the social distribution of the innovation. The findings of studies of variation and change show that, at any given point in time during a change, speakers with high rates of use of the innovation coexist in the community with speakers with low rates. The social significance of these varieties will be apparent to members of the speech-community: the lower rates will be associated with the old, and the higher rates will sound new and young.

Studies of change in progress indicate that speakers do have an awareness of what is old and what is new, what is archaic and moribund in their language versus what is fresh and expanding. Sometimes this awareness is unconscious, but often it is quite conscious: in Australia, for example, virtually everybody contacted for the Horvath and Guy study (Guy et al. 1986) was aware of the innovative nature of the high-rising intonation in declaratives, and its subsequent spread into North America has been the subject of similar overt public awareness. The dynamic nature and direction of movement of changes that happen in one speaker's lifetime will be available to that speaker: hence the

“succession in time” is part of our knowledge of linguistic facts. The linguist not only can but also must pay attention to diachrony in achieving understanding of those facts.

Second, what speakers don't know about diachrony doesn't matter: the “absolute opposition” between synchrony and diachrony breaks down completely if variation is the fountain of change, and the mechanisms and directions of change are inherent in the variability of the community today. Insofar as change is driven forward by inherent social and linguistic processes, the speakers involved don't need to know about the previous history of their language any more than Galileo's falling objects needed to know about their history in order to reach the base of the Tower of Pisa. All speakers need is to have a human language apparatus, normal abilities for language production, perception, and acquisition, and normal acculturation in their society. Changes will arise as a consequence of the intrinsically dynamic and variable nature of language and society.

Therefore, one consequence of the integrated view of variation and change is that it requires an integrated view of linguistic theory. An adequate account of variation and change cannot be achieved if we maintain Saussure's uncompromising opposition between synchronic and diachronic linguistics. The traditional division depends on the view that synchrony is static and categorical, while diachrony is variable and dynamic. But the findings presented here subvert both sides of this dichotomy. On the one hand variation shows a dynamic face in synchrony, and on the other hand, the “orderly heterogeneity” we find reflected in things like the stability of constraint effects and the constant rate hypothesis demonstrates the diachronic preservation of system and structure. Consequently, a better understanding of the linguistic facts within and across points in time will be achieved with an integrated, post-Saussurean view of language.

ACKNOWLEDGMENT

The author's work on this chapter was supported in part by the Social Sciences and Humanities Research Council of Canada (grant # 410-97-1431), and by a Research Development Fellowship from York University.

NOTES

1 The Uniformitarian Principle is the elementary hypothesis that the conditions and mechanisms that affect language change today (and

in recorded history) are the same as those that operated in the past (cf. Labov 1994). On an evolutionary timescale, this hypothesis would

- have to be qualified, but it is the preferred postulate for events occurring during the existence of our species, *Homo sapiens sapiens*. (For further discussion, see the introduction to this volume, section 1.2.2.)
- 2 One theory of constraint effects, Optimality Theory, postulates all constraints to be universal, but even OT allows for language-specific effects, arising from either the details of constraint rankings, or in some cases from parameterization. See section 3.3 for further discussion.
 - 3 Any differences in constraint effects will of course be limited to those that are language-specific; universal effects would necessarily be constant across time, at least for less than evolutionary timeframes.
 - 4 The issue of acquisition and change is touched on only briefly here and in section 4.1. For a focused treatment of this subject, see Aitchison, this volume.
 - 5 See Pintzuk, this volume, for a discussion of variationist approaches to syntactic change.
 - 6 The study also examines data on a few lexical and syntactic variables, with similar results.
 - 7 For further treatments of the Neogrammarian hypothesis and lexical diffusion, see Hale and Bybee, this volume.
 - 8 Of course morphological constraints in general, although they are not lexical, are still somewhat problematic for a strict Neogrammarian position because they are not clearly phonetic, although boundary effects have been treated as phonetic constraints in some approaches (e.g., “juncture”). See Hale, Janda, and Hock, this volume, for further discussion of non-phonetic conditioning of sound change.
 - 9 Phonetically, the tense variant is more peripheral and has a centralizing off-glide, and tends to be longer than the lax variant. For many speakers the tense variant is also subject to raising and fronting. Further discussion of this split can be found in Labov (1994) and Kiparsky, this volume.
 - 10 Note that this conclusion depends on regularity. If individual words had their own patterns of variation, it would be difficult to determine the direction of any process in any word, or the prevalence of any particular directionality.

9 “Phonologization” as the Start of Dephonetization – Or, On Sound Change and its Aftermath: Of Extension, Generalization, Lexicalization, and Morphologization

RICHARD D. JANDA

From the time of the earliest diachronic investigations into the sounds of languages, it has been clear that sound change is not a “forever” phenomenon: a sound change may arise at any given time, but it typically runs its course within a relatively short temporal span (for further discussion, see section 6 below). This fact is recognized in one of the key questions raised by Weinreich et al. (1968) as part of their groundbreaking manifesto on the role of social factors in language change – namely, in what they asked in connection with the “actuation” problem: why did a given linguistic change occur at the particular time and in the specific place that it did? This query in turn echoes the question provoked by Coseriu’s (1958) “historical” problem of language change: why does any particular change occur when it does? Moreover, the majority of diachronic linguists have long understood that it is not enough simply to allege that any single set of factors (whether purely linguistic or even purely external) was sufficient to bring about a given sound change; rather, sufficient conditions are provided by numerous situations, but not all of these lead to sound change(s) – especially not to the same sound change(s). For example, nearly all languages have some fronting of velars before front vowels, but not all languages show (full) palatalization of such velars, even though the latter commonly occurs and is – in some sense – a phonetically “natural” change. Nor do all languages that “do something” to such a sequence resolve it in the

same way: palatal affricates are a common outcome, but so also are (alveo)-palatal fricatives, dental or alveolar affricates, and the like.

Consequently, each change that takes place presumably has its own set of activating factors, and thus some definite starting-point. And it is just as clear that sound changes have ends, too – the presence of a sound change at one stage in the history of a language does not somehow “oblige” speakers of that language, as it were, to maintain the same change in generation after generation, century after century. For instance, the loss of /p/ in pre-Old Irish (cf. *athir* ‘father’, from Proto-Indo-European (PIE) *pāter-) did not prevent Irish at a later stage from acquiring a /p/ through loans from Latin in the historical period,¹ nor did the change of PIE *d to Germanic *t (cf. English *ten* and Gothic *taihun* ‘10’, from PIE *dekṃ) keep Germanic speakers later on from altering PIE *dh so as to create a /d/ once again (as in English *do*, from PIE *dhē-). Hence it is not only the case that a sound change always has a beginning and thereby enters a period during which it is active; a sound change also has a point at which it ends.

It is therefore not surprising that some scholars, by using such terms as “lifespan,” “life cycle,” and similar biologisms, have talked about sound changes as if such entities had a three-stage life:² That is, they begin with a start; then comes a period during which they flourish and perhaps even could be said to “grow,” and at last (typically) there is an end, once they have not only gone to completion but also – if they do not survive in the form of synchronic grammatical generalizations that are motivated by contemporary alternations – become inactive. The present chapter only cursorily explores certain aspects of the first two relevant stages – what happens at the outset of a sound change, and what happens during its active existence – in order to focus more thoroughly on the end of the third stage and what follows – on what happens in the aftermath of a sound change (i.e., after a generalization no longer has the purely phonetic or at least purely phonological conditioning which once gave it Neogrammarian regularity). Relevant here are extensions and generalizations of various kinds (sometimes partial, for example), including lexicalization and morphologization. Due to this chapter’s many links with morphology (and the lexicon) as well as phonology, its (proper) inclusion in the “Phonological Change” part of the current volume is in fact somewhat arbitrary. Still, given that morphologization and lexicalization tend to represent developments arising out of an earlier phonological stage, the present arrangement seems preferable to various imaginable alternatives. (The latter include splitting the chapter between the “Phonological Change” and the “Morphological and Lexical Change” parts, assigning it solely to the latter, and including the chapter (entire) in both parts.)

1 Some Theoretical Preliminaries

The ensuing discussion of sound change rests on several key points which are here enumerated with relatively little justification because they represent widely accepted (though not universally held) assumptions that are widely acknowledged in the general linguistic literature (even if they are not totally uncontroversial, and should perhaps even be challenged more often):

- i As a start (but see sections 3–4 below), the validity of the phoneme as a linguistic and (possibly) psychological construct is assumed; what is particularly important for most diachronicians – as well as synchronicians – of language is the principle that complementary distribution of sounds, coupled with some degree of phonetic similarity, is the primary basis for identifying a phoneme as an abstract unit of analysis subsuming the various phonetic realizations known as its allophones.
- ii At some point during its active period (its “lifespan”), a sound change has a phonetic basis; for the Neogrammarians and their followers, sound change was, and is, in the words of Bloomfield (1933: 364), “a purely phonetic process,” whereas others (e.g., Kiparsky 1995b/this volume) view sound change in more abstract terms (e.g., as a generalization of originally low-level phonetic processes from the post-lexical to the lexical-phonological domain), though they do not deny that there is a role for phonetics at some stage (cf. Janda and Joseph 2001).
- iii Sound change is not instantaneous, but instead spreads and diffuses; to some extent, this issue is the same as that characterized by Wang (1969) as “abruptness,” since it concerns whether the implementation of sound change is “lexically abrupt” – that is, instantaneous across the whole lexicon – for a given set of phonetic conditions that are met in a number of lexical items. This is the position that Bloomfield (1933: 351), as a standard-bearer for the Neogrammarian view of sound change, believed that he had expressed in his statement that “phonemes change” – which, by claiming that what changes in sound change is (the phonetic content of) abstract phonological units, presumably means that the change at issue is globally implemented (once the phonetic conditions are properly specified) wherever the relevant units occur in the lexicon.
- iv Social factors play a critical role at least in the diffusion of sound change, as the work of Labov over the past 40 years has made irrefutably clear (for discussion and references, see, e.g., Labov 1963, 1972a, 1994, 2001; Guy, this volume; Janda and Joseph, 2001, this volume).

With these preliminaries in place, the present examination of what can happen to sound change in its post-inception phase(s) is now ready to proceed.

2 One Possible Outcome: Morphologization

2.1 *Background and overview*

In light of the current ascendancy of constraint-based, surface-oriented Optimality Theory (OT), let us begin with the most extreme sort of aftermath of sound change, and thus mention that one outcome for the relevant processes of generalization (of “spread”, in an extremely broad sense of that term) is for a sound change to become completely divorced from phonological considerations altogether, and so to pass into what can be characterized as “(the) morphology.”

If one works within a theoretical framework which includes a distinct type of morphological rules and/or constraints, as well as phonological and syntactic generalizations, one is inevitably forced, when confronted, in a given language, with a specific phenomenon that involves sound(s) to at least some degree, to grapple with questions of type assignment. (The corresponding issue in a model of grammar where the different types of generalizations are all separated into unitary components is the question of specifically where in a grammar a given phenomenon is to be situated.) There are some theories, of course – for example, classical generative phonology à la *Sound Pattern of English* (Chomsky and Halle 1968), or lexical phonology (cf. Kiparsky 1982ff) – which blithely avoid difficult questions like these by simply denying the need for a separate rule-type (or component) dedicated to all and only aspects of word-formation in its broadest sense (i.e., to derivation as well as to inflection).³ But, in light of the compelling arguments presented by Anderson (1992) – and indeed, by most linguistic traditions before him – in favor of recognizing differences in the ways that morphological rules and other types of rules must be treated in a grammar, the burden of proof would seem to rest on anyone who would attempt to deny a special type or place to morphology. In what follows, therefore, it is assumed that linguistic theory cannot ignore morphology, and so cannot shirk, but must instead always address, questions regarding the proper grammatical type or grammatical location that should be assigned to particular analyses for sound-based phenomena.

Synchronically, it is clear that not all manipulations of sound must necessarily be a matter of phonology pure and simple. That is, there are some alternations in the shapes of certain lexical items which cannot be reduced to statements of rules or constraints that take into account nothing other than elements of sound structure. For instance, classical generative phonology often invoked generalizations of the type sometimes called “morphologically conditioned phonological” rules – which state apparent sound alternations but are crucially conditioned by non-phonological features of various kinds. The latter can be morphosyntactic (e.g., [+dative], [+3sg.]), morphosemantic (e.g., [+agentive]), or morpholexical (e.g. [+o-stem]) in nature, or they can even belong to other, difficult-to-characterize categories of morphological features (on the general

topic of how feature types can be most insightfully classified, see Zwicky 1986, 1987). For a quite well-known example of an at least partly "morphologically conditioned phonological rule" in English, consider so-called "Trisyllabic Laxing/Shortening" – which, in spite of the first part of its name, applies not only before certain bisyllabic endings (as in *wild/wild-erness*, though not in *wine/win-ery*) but also before certain occurrences of the monosyllabic suffixes *-ic* and *-id* (as in *mime/mimic*, though not in *scene/scenic*). For discussion and references, see Janda (1987: ch. 1, appendix) – who, however, along with a number of others, has argued that limited scope regularities of the sort just mentioned are actually a subtype of morphological rules/generalizations, not instances of phonological rules, per se (see also Joseph and Janda 1988: 197n.3 on the more general topic of ways to distinguish, in certain ambiguous cases, between phonological and non-phonological generalizations).

There are also unique alternations that do not generalize to (other) phonologically parallel cases. The clearest such instances involves suppletion, as between present *go* and past *went* in English; here, no phonologically similar verb shows a similar alternation (cf., e.g., *glow*/**wlent*, *goad*/**wented*, etc.). There are, however, less drastic alternations that thereby present more intriguing challenges. Consider, for instance, the allomorphs *a/an* of the English indefinite article: here, alternations of sounds are definitely involved – specifically, the presence versus absence of final *-n* (and this still leaves aside the vocalic differences in the two variants) – and here, in addition, the conditioning environments for the alternants can be stated purely in terms of sound. That is (as is well known), *an* occurs before vowels, while *a* occurs before consonants (for the most part – i.e., if one leaves aside the fluctuations that are found before *h*: e.g., *a historical explanation* versus also *an historical explanation*).⁴ No other morpheme shows a similar alternation; the definite article *the*, for instance, does not have a pre-vocalic form **the-n*.⁵ It is difficult, therefore, to see the alternation of *a/an* as a matter of phonology in any significant sense, particularly if phonology is viewed as that aspect of grammar which allows generalization over categories that are purely phonological (i.e., which have traditionally been labeled "non-grammatical").⁶

Similarly, there also probably exist some cases which are simply not very clear, in the sense that their degree of "phonologicality" depends on how the relevant analysis goes. For example, the "mutations" shown by certain word-initial consonants in various environments within the Celtic languages seem at first glance to be certifiably non-phonological, given that homophonous elements can trigger different mutations and that factors pertaining to syntactic structure can also play a role in whether particular mutations occur or not. Such an approach is most massively the case under the traditional analysis: for example, that implicit in Lewis and Pedersen (1937). Nevertheless, putative purely phonological accounts of the Celtic facts have been proposed – ones which utilize floating autosegments as triggers for the needed mutations (cf., e.g., Lieber 1987). However, such analyses are possible only at the expense of sometimes assuming very abstract triggers, and there are other mutations in

various Celtic dialects for which even such abstract analyses cannot work straightforwardly and have therefore never been suggested; see, for example, Thomas-Flinders (1981) on lenition in the Scots Gaelic of Leurbost, Isle of Lewis.

Potential ambiguities as to the type or component with which a given sound structural phenomenon is best associated are reflected diachronically by the mobility that exists between the various types or components at different stages in a language's history. Under the strictest view as to where the borders between phonology and other rule/generalization types are located, "movement out of" (i.e., an association with some other type or domain than) phonology occurs when one or more non-phonological features/attributes begin to be associated with what was once purely formal (i.e., phonetic or phonological) conditioning of a given phenomenon. Moreover, such movement is a matter of degree, since there can be, for example, increasing (morpho)lexicalization as a phenomenon comes, for whatever reason, to have morphological and/or lexical exceptions. This is even more clearly true as regards the aftermath of sound change: the Celtic mutations, for example, are the result of sound changes triggered by combinations of certain word-final segments (e.g., vowels or nasal consonants) with certain initials in immediately following words – the conditions for which were then altered by changes eliminating various word-final segments, even though the original effects on the initial segments remained. This situation was then reinterpreted by subsequent generations of speakers either as involving abstract phonological triggers, under one of the views outlined above of what constitutes phonology, or as involving non-phonological triggers, under the other view. But, whichever sort of explanation one prefers, sound changes were the crucial starting-point for all later generalization, alteration, or reinterpretation.

To the few examples of this sort already referred to here, numerous similar cases could be added, such as that of consonant gradation in Finnish (cf. Holman 1985)⁷ or that of accent placement in post-Classical Greek (cf. Joseph and Janda 1988), particularly as regards the latter's interaction with the so-called "augment." But two more examples will be given brief mention here before attention is turned to an in-depth examination of one case that is particularly richly documented and thus invaluable for what it shows about the processes operative in the aftermath of sound change.

2.2 German participial ge-: mostly morpholexical, partly phonological conditioning

In the specific case of the German past-participial prefix *ge-* (cf., e.g., Paul 1917: 276–9; Kiparsky 1966: 70–5; Joseph and Janda 1988: n.13), matters are in general very similar to the examples already discussed above. The Germanic perfective marker **ga-* (as in Gothic *ga-*), which essentially could appear on any verb form in any tense, was in Old High German restricted to marking only past participles – as *gi-* (which became Middle High German *ge-*). Such participles lacked *gi-* only if they belonged to an inherently perfective verb

or already possessed certain other prefixes. By the Modern High German period, these conditions had been reanalyzed (and altered) so that *ge-* now occurs as a past participial prefix except when the initial syllable of a verb stem to which it would otherwise be added is unstressed. This change clearly represents a phonologization of the rule(s) for the occurrence of a morphological element. But (as with one account for the above-mentioned Greek augment; cf. Joseph and Janda 1988), the case of German *ge-* does not represent an instance of demorphologization in the sense developed here, since the relevant process – of *ge-* omission or deletion – remains a fact about a particular morpheme (or set of morphemes), and this conclusion is only strengthened by the experimental-psycholinguistic results of Wolff (1981). That is, the rule for *ge-* has not been so phonologized as to become a morphemically/lexically free process of German sound structure. Rather, it has remained a morphological (and even morpholexical) rule, albeit one with more extensive phonological conditioning.

2.3 Spanish "feminine" *el*: relentless morpholexicalization-plus-dephonologization

A parallel case of morpholexicalization – but one involving the decreasing importance of external sandhi (and syllable-structural) conditioning – is provided by the so-called "feminine" *el* seen in Spanish *el agua fría* 'the cold water,' *el alma mía* 'my soul,' etc. Here, even in Romance, there thus exists a strong precedent for us not to be surprised by non-syllabically conditioned reanalyses. The developments leading to the existence in Spanish of feminine nouns preceded by apparently masculine *el*, as in *el alma*, has often been seen as supporting the invocation of ONSET constraints (cf, e.g., Mascaró 1996), but the course of this evolution was in fact roughly as follows (see Malkiel 1981: 101–2; Posner 1985: 441–6). The Vulgar Latin distal demonstrative *illa* (feminine singular) first underwent syllable-structurally conditioned processes reducing it to vowel-final (*il*)*la* in pre-consonantal position but to consonant-final *ill(a)* in pre-vocalic position, with these changes presumably reflecting the purely phonological constraint ONSET. Given that the subsequent development of (feminine singular) *illa* > *ill* > *ell* > *el* intersected with the change of (masculine singular) *ille* > *ill* > *ell* > *el*, Spanish eventually ended up with *el* as a uniform (singular) definite determiner before both feminine and masculine vowel-initial words.

Later, however, so many morphosyntactic and lexical conditions accreted onto this "feminine" *el* that they gradually reduced the scope of its general phonological conditions. Thus, though *el* (and not *la*) in feminine noun phrases first occurred before a word starting with (i) any vowel, the vowel in question subsequently had to be (ii) *a*, then (iii) stressed *á*, next (iv) stressed *á* in a noun, later (v) stressed *á* in a noun other than the name of a person, city, or letter, and finally (vi) stressed *á* in a noun other than the name of a person, city, or letter or any of certain idiosyncratic lexical items. And it is even known that

one grammarian (the influential Venezuelan Andrés Bello (1781–1865)) was mainly responsible for the form of the current standard norm.

Presently, two developments seem to be going on with Spanish “feminine” *el*. For some speakers, it is coming to be viewed as completely idiosyncratic, occurring only before (vii.a) a small, closed set of arbitrary lexical items that all happen to be nouns starting with stressed *á* (cf. Posner 1985 on, e.g., *el alma* ‘the soul’ versus *la alma* ‘the cannon-part’). For other speakers, though (at least in Spain), *el* still precedes (vii.b) most feminine nouns beginning with stressed *á* (like *alma*), but these words have been reanalyzed as having the rather unusual morphosyntactic property of *lateral hermaphroditism* (cf. Janda and Varela-García 1991). That is, these *á*-initial nouns take masculine agreement to the left (whereby *el* may immediately precede, e.g., a masc(uline) consonant-initial adjective) but fem(inine) agreement to the right – thus, *el cristalino agua esa* ‘the (masc.) crystal-clear (masc.) water (fem.? / masc.+fem.??) that (fem.)’, = ‘that crystal-clear water,’ is favored by many speakers over prescriptive *la cristalina agua esa*; similarly with *el buen hada madrina* ‘the good fairy godmother(ly)’ rather than prescriptive *la buena hada madrina*. This is surely an extreme of non-phonological conditioning in the history of Spanish “feminine” *el*.

The Vulgar Latin starting-point here was indeed ONSET-satisfying (re)syllabification, but the Spanish mid- and end-points all crucially involve morphosyntax and the lexicon, with a certain amount of arbitrary phonological baggage left behind. That is, the end result here is not the interface of two pure grammatical modules but (as in French suppletive liaison; cf. Janda 1998a) an internally disparate pattern (idiom/construction) – an “intraface” (cf., e.g., Joseph and Janda 1988 on such local generalizations). Hence the preference for purely phonological syllable-structural constraints in current OT must be tempered with greater provision for morphological and lexical constraints (like those also needed for a full account of French suppletive liaison; again cf. Janda 1998a).

2.4 *The situation so far*

With these examples under our belts, as it were, we are ready to devote detailed discussion to one especially well-known case in which the end-station of a sound change, so to speak, is a new “life” as a grammatical/morphological rule. The case in point is (High) German umlaut – a vowel-fronting process that was once conditioned entirely by the presence of a front vowel or glide in a following syllable but was later transformed, at some point, into a process linked to the expression and presence of particular grammatical categories. As it happens, though, the story of umlaut in German involves far more than merely the above-mentioned sort of “dephonologization,” or “morphologization,” or the like, and so it is worthwhile to scrutinize that phenomenon closely, in order to appreciate just how manifold and varied the aftermath of a sound change can be.

3 An Extended Case Study: (High) German Umlaut

3.1 Overview

In light of the current ascendancy of constraint-based, surface-oriented OT (growing largely out of the work of Prince and Smolensky 1993), contemporary phonologists and diachronicians now cast a less jaundiced eye on post-Bloomfieldian American structuralist accounts of phonological change, with their focus on constraints governing the distribution of surface elements. Twaddell's (1938) treatment of High German umlaut is probably the most famous such account; for example, it was treated by Joos (1957) as nothing less than a revolution in diachronic phonology. Korhonen (1971) observed, however, that essentially the same account had already been proposed in Finnish by Valentin Kiparsky (1932)! Be that as it may, Twaddell (1938) claimed that the front-rounded phones [ü(:)] and [ö(:)] were not orthographically indicated in Old High German (OHG) because they were respective allophones of /u(:)/ and /o(:)/ conditioned by /i(:)/ or /j/ in a following syllable. When these triggers either were reduced to schwa or disappeared, the new phonemes /ü(:)/ and /ö(:)/ were created; hence Middle High German (MHG) orthography tended to use distinct symbols for them.⁸ But there is a logical problem here: if the front-rounded phones [ü(:)] and [ö(:)] were allophonically conditioned by following /i(:), j/, then loss of such triggers should have been accompanied by loss of the fronting effect which they conditioned (cf. Kiparsky 1995b: section 2.1). This drawback justifies the assertion that praise for Twaddellian accounts of phonemic split has been greatly exaggerated. (The Twainian allusion here is fleshed out in section 3.2 below.)

Attempts to resolve the contradiction that is inherent in Twaddell's approach have been almost as numerous as they are unknown. Many such accounts (especially early ones) were summarized by Dressler (1985b), Liberman (1991), and Fertig (1996), while explicit statements on this issue have been made by Dressler (1972), Hooper (1976a), Hyman (1976), Anttila (1989), and Haiman (1994). The consensus of these counter-Twaddellian trends is that phones such as [ü(:)] and [ö(:)] must have become phonemic (for Hyman: must have been "phonologized") *before* reduction or loss of [i(:), j]. Since new phonemes of this sort have what has been called a defective distribution, they have received names like "marginal," "quasi-," or "secondary" phonemes. Yet these analyses provide neither any motivation for *why* nor any mechanism for *how* certain (later-to-be-former) allophones which are in complementary distribution could become phonologized. In this sense – that they give no satisfying reason for why the separateness of such allophones was extended to the point where they were (re)categorized as distinct phonemes – the non-distributional accounts in question are not exaggerated enough.

Yet precisely two kinds of linguistic exaggeration – motivated in phonetic studies like those made by Ohala (1989, 1993a, this volume) and in sociolinguistic works like Labov (1972a, 1994) – explain why and how certain allophones could become phonologized while still in complementary distribution. Crucially, there exist pairs of sounds whose individual phonemic status cannot be questioned even though their distribution is sufficiently defective for them to be complementary: for example, English /h/ (aitch) and /ɱ/ (angma), whose phonetic distance is criterial for their distinctness. But there is no reason why the pronunciations of two allophones of a single phoneme cannot, over time, diverge phonetically to a point where they differ phonetically as much as do /h/ and /ɱ/ – and so undergo phonologization (i.e., reanalysis as two distinct phonemes). This is in fact exactly the thrust of Ohala’s work: sound changes arise via the growing exaggeration of physiologically or acoustically motivated phenomena – as in Ohala’s “hypocorrection” and “hypercorrection.” Another reason for such exaggeration relates to the consistent emphasis of quantitative variationists like Labov on a second overgeneralizing practice: the tendency for a group of younger speakers to mark its generational status by extending the domain of phonological patterns via generalization of their – that is, the patterns’ – degree (or, phrased in terms of rules, their effect), their set of inputs, and/or their environment. Without fear of exaggeration, then, we may conclude that phonological reanalysis can indeed occur before the loss of a conditioning environment.

Below, this unconventional finding is supported by discussion which expands, in turn, on each of the preceding three paragraphs.

3.2 *Twaddell and then twaddle*

Responding in 1897 to the consternation provoked when he was reported dead while still very much alive, Mark Twain (pseudonymous for Samuel L. Clemens (1835–1910)) wrote as follows to the London correspondent of the *New York Journal*: “The report of my death was an exaggeration” – often quoted as “(Reports or) Accounts of my death have been greatly exaggerated.” In the case of Twaddell’s (1938) treatment of High German umlaut, however, exactly the opposite holds: reports of the viability of this account have been greatly exaggerated.

After all, the basic assumption that the OHG [ü(:), ö(:)]-allophones of the phonemes /ü(:), ö(:)/ existed *only* in the conditioning presence of a following /i(:), j/ is hardly compatible with the claim that such front rounded allophones became phonemicized after – and because – their former conditioning was *lost*: one would instead simply expect [ü(:), ö(:)] to have been lost, too, in favor of [u(:), o(:)]. But precisely this scenario – that is, loss or neutralization of a formerly conditioning environment as a mechanism for phonemicizing once merely allophonic distinctions – is implied by Twaddell and had explicitly been stated six years earlier by V. Kiparsky (1932).⁹ Discussing the parallel

development of the (presumably pre-OHG) low front vowel [ä] – originally an allophone of /a/ – V. Kiparsky thus suggested that MHG "speakers['] fe[e]ll[ing] . . . that the sound [ä] was a different phoneme from the phoneme /a/ . . . arose after the transition of unstressed [i] . . . to the indefinite vowel . . . [schwa]" (p. 245; my translation of the German version in Korhonen 1971).

As documented in great detail by Liberman (1991: 126–7), "the same fatal question" – the same "paradox of phonologization . . . as presented by Twaddell's school" – had begun to elicit individual reactions of bewilderment and even "absolute dismay" during the 1950s, and these isolated critical voices have been heard right up to the present. Yet, "despite all its weaknesses, Twaddell's model stands like a rock in all the phonological tempests of the last half-century," with "[s]tandard textbooks . . . and surveys . . . singl[ing] . . . out the 'American' explanation of umlaut as the greatest achievement of phonology" (Liberman 1991: 127). See, for example, Joos (1957: 87): "Nowadays we expect every discussion in historical phonology to be in harmony with 'phonemic theory' . . . and . . . [its] principal role . . . , but . . . [Twaddell's (1938)] paper was a startling novelty when . . . published – except for those who . . . saw that this was plainly the right way to do things . . . [Though a] large fraction of . . . linguistic[s] . . . has its origin in Germanic philology, . . . [t]his paper begins to repay the debt."

Essentially papering over the conceptual problems of Twaddell's approach with a convenient term, Hoenigswald (1960) bestowed the name "secondary split" on "the situation in which a change elsewhere in the system . . . turn[s] the allophones of one phoneme into distinct phonemes . . . [B]riefly, allophones become phonemes when part or all of their determining environments fall together without at the same time canceling the phonetic difference between the allophones in question" (pp. 93–4). Here, the brute-force inclusion of "without at the same time canceling the phonetic difference" directly reflects the insoluble difficulty of any approach which denies that phonemicization occurs prior to the loss of the former conditioning environment. That is, since the relevant upgrading of allophones cannot really follow the environmental neutralization in question, the only remaining possibility is to posit two absolutely simultaneous but independent changes: phonemic split, and loss of one or more conditioning factors. But, in the latter case, there is no apparent reason why phonemicization should suddenly sunder the phonemic unity constituted by a state of complementary distribution, or why phonemic split should accompany an environmental neutralization.

That serious, inherent flaws of this sort should have managed to escape Twaddell's attention is understandable: he was reacting to the atomistic methods of many Neogrammarians. But the twaddle involved in purveying exactly the same views to students (even graduate students) of introductory historical linguistics almost sixty years later is hard to comprehend. Cf., for example, Trask (1996), who explicitly discusses the "development . . . called *loss of the conditioning environment*[:] the . . . [segment] that had formerly conditioned . . . [one] allophone . . . was lost, and hence the distribution . . . was no longer

predictable; thus . . . [,] the former phoneme split in . . . two . . . [–] one phoneme simply divide[d] . . . into two phonemes” (p. 78; original emphasis). Still, the fact that this view remains common cannot at all be held against the surprisingly numerous scholars who have discussed its problems at length and suggested alternatives, even though their arguments have had little resonance in the literature.

3.3 *So phonologization is early – but why?*

Just as V. Kiparsky (1932) anticipated by a full six years Twaddell’s (1938) phonologization-via-environment-loss account of OHG/MHG umlaut, so Liberman (1991: 126) has observed that, as early as the early 1930s, “Jakobson (1931) realized the intrinsic weakness” of the “model that we associate with Twaddell” and “never commented on . . . [the] article.” Liberman also lists numerous articles (in Russian) by Soviet scholars of the 1950s and 1960s who emphasized the internal contradictions involved in assuming phonemicization at (or after) the exact moment of environmental neutralization and therefore came to the only reasonable remaining conclusion. This is that phonemicization/phonologization must precede the loss of a former conditioning environment, and that morphosemantic, morpholexical factors are likely to play a crucial role thereby. Likewise, Fertig (1996) at some length and Janda (1998a) in passing (p. 197; cf. also pp. 216–17n.10) observe that a number of American and European scholars reached exactly this conclusion regarding OHG/MHG umlaut in the 1960s and 1970s – and that the perspective of these writers has simply been ignored.

As might be expected from the ability of historically minded generative phonologists to use long derivations to maintain underlying forms from much earlier eras despite the phonetic vicissitudes which have altered their surface forms, most pre-OT generativists adopted basically an updated Twaddellian view. Thus, concerning OHG/MHG, P. Kiparsky (1971: 634) wrote that “[t]he elimination of the conditioning *i* and *j* turned the umlaut rule opaque . . . [;] at some point *after* this took place, umlaut *started* to be reanalyzed as a morphologically conditioned process” (my emphasis). In the face of this view (essentially the party line), little or no headway was made by the divergent claims of Dressler (1972, 1985b), Hooper (1976a), and Hyman (1976) in the 1970s and 1980s, or by Haiman (1994) in the 1990s. Rather, their phonologization-before-environment-loss approach, with its phonemes in complementary distribution, later elicited from P. Kiparsky (1995b/this volume) the reaction (1995b: 657) that, for example, “Korhonen[’s] (1969: 333–335) suggest[ed] quasi-phonemes” are “perceptually implausible,” and so to be dispreferred to an (analogical) “*priming effect* . . . [whereby r]edundant features are likely to be phonologized if . . . [a] language’s phonological representations have a class node to host them” (original emphasis).

Yet precisely the case of OHG/MHG umlaut shows that P. Kiparsky's proposal is untenable, since there certainly is no motivation, in an under-specification analysis, for assigning pre-OHG vowels a [round] feature or a Labial node, and appealing to the presence of a general V[owel]-Place node wildly overpredicts what sort of vocalic changes are possible and so should have been observed in the course of over a millennium. Still, P. Kiparsky's paper is useful in revealing what it is that makes both diachronic and synchronic phonologists reject (or at least ignore) with such vehemence the numerous and repeated claims that have been made in favor of phonemes in complementary distribution: their proponents "do not spell out the conditions under which allophones acquire this putative quasi-distinctive status" (p. 657). This trait suffices to give marginal/quasi-/secondary phonemes the status of Pandora's box: if some apparent individual phonemes, each with multiple allophones, are really disguised *sets* of phonemes in complementary distribution, where and how can one draw the line and say that not all allophones are actually distinct phonemes?

Actually, a principled answer to this question has been given at least twice (in roughly the same form), but it unfortunately has suffered from insufficient explicitness, in the case of Ebeling's (1960: 136–9) version, and from having been undercut by a conjoined contradictory proposal, in the case of the later avatar diffidently discussed by Hooper (1976: 86–91). The crucial element here involves *phonetic similarity versus phonetic dissimilarity (difference)* – that is, *phonetic distance* – between sounds which begin as co-allophones (all belonging to the same phoneme) and end as distinct phonemes. Hooper (p. 90) cautiously raised the possibility that the "difference between . . . [two sounds might be] too great phonetically for them to be considered mere variants of one another, and that they will be interpreted as separate entities . . . [;] there may be substantive constraints on what may be a natural alternation . . . [,] and . . . alternations that progress beyond the natural limit may lead to restructuring." (Cf. also Comrie's 1979 study of morphophonemic exceptions and phonetic distance, and now Bybee 2001, plus her references.)

Lamentably, though, Hooper (1976) prefaced these remarks with a discussion (p. 90) which falls into the very contradiction plaguing Twaddellians: "as . . . [a nasal] consonant weakens, . . . language learners will . . . confront . . . a nasalized vowel followed by a consonant so weakened that the [vowel's] nasality will not be considered redundant, . . . but rather . . . a nonpredictable feature." Here, once again, it seems that such vocalic nasality would have been attenuated along with its conditioning nasal consonant – unless the vowel in question had already been reanalyzed as distinctively nasal. There thus indeed remains a need for a solid foundation that can anchor attempts to invoke phonetic distance as a force in phonemicization. Nor did Hooper (1976) – or, earlier, Ebeling (1960) – cite existing sociolinguistic research which could have provided a mechanism to yield increases in phonetic distance between allophones.

4 Phonetics, Psyches, and Social Factors

4.1 *Phonetic distance and phoneme-as-category*

Yet the wherewithal for rendering (more) plausible the proposition that former co-allophones may end up as distinct phonemes even while they are still in complementary distribution – and for reasons having to do with phonetic distance – has long been at hand. After all, it is a common “teachable moment” of introductory phonology courses that, because of their great phonetic dissimilarity, English /h/ (aitch) and /ŋ/ (angma) must be reckoned as distinct phonemes, even though their defective distributions are in fact complementary (/h/ never occurs in a syllable coda; /ŋ/ always occurs in a syllable coda). But we can then ask if any known principle of phonological change would prevent two sounds which originally were allophones of the same phoneme from eventually becoming as phonetically distant as /h/ and /ŋ/. In fact, no such principle exists, and so there is nothing to rule out long- or even short-term developments whereby former co-allophones ultimately come to be so phonetically dissimilar that they are recategorized as realizing two separate phonemes.

The crucial element here is indeed (re)categorization. For all the current emphasis on cognitive science in contemporary linguistics, it is difficult to resist the conclusion that the dominant strain of generative phonology, despite its mentalist origins and orientation, continues to shlep along essentially an anti-mentalist post-Bloomfieldian structuralist notion of the phoneme as primarily a distributional category. And the Achilles’ heel of this category is phonetic (dis)similarity. In no other (sub)discipline would any self-respecting researcher seriously employ the default assumption that any two entities occurring in complementary distribution are members of the same cognitive category unless they are too dissimilar from each other. Instead, a perspective with something like exactly the opposite orientation makes a lot more sense: that entities are unlikely to be members of the same category unless they are extremely similar (preferably along several, but at least along one or more, dimensions), and then only if they occur in complementary distribution. In that case, a phonologist would always bear the main burden of proving that any two putative co-allophones in fact possess sufficient phonetic similarity to be categorized as instantiating the same phoneme.

Of course, what would help most to resolve this line of debate is psycholinguistic data regarding categorization in and of itself. In fact, some such evidence exists, and it tends to falsify the expectations of synchronic and diachronic phonemicists. For example, during the early 1960s, Moulton (1961a) wrote (here in my translation) that “the normal speaker is simply not aware of the allophones of his/her native language” – a claim which he adduced as an explanation for the alleged fact that, “in a normal orthography (i.e., apart from scholarly phonetic transcriptions, etc.), allophones of the same phoneme are

never, ever distinguished in writing" (original emphasis). To begin with, the last claim here is simply false, as shown by Voyles's (1976: 21–2) discussion of five allophonic distinctions reflected in some of the very OHG texts discussed by Moulton. More crucially, though, relatively recent psycholinguistic research by Derwing et al. (1986) shows (p. 53; original emphasis) that "*some* sub-phonemic differences can be perceived by phonetically untrained monolingual speakers," and "a more powerful experimental design aimed at more specific questions might well show that . . . other distinctions are also perceptible, at least to some speakers," since their data already exhibit "a range of variation which is highly suggestive in this regard."

Hence Derwing et al. (1986: 53–4) argue that, "[t]aken together with . . . Jaeger's . . . [(1980)] study, . . . this gradation in fact suggests . . . that it is perhaps quite incorrect to regard the phoneme as the sharply defined kind of category that one finds in classical set theory." Rather, the phoneme is "something more akin to a 'natural category' . . . in the sense of Rosch . . . [(1973): i.e.,] one that is best represented by a particular prototype exemplar, with other members tailing off gradually . . . [;] see Jaeger and Ohala [(1984)]." Indeed, it is arguably the case that, given the way in which, from an original unity, allophones develop from one another, differentiate, diverge, and may eventually come to be reinterpreted as members of distinct mental entities, phonemes are radial categories in the sense of Lakoff (1987). Such developments in fact also show close parallels with the treatment of diminutive semantics by Jurafsky (1996), who documents the various sorts of extensions and transfers through which a word for 'child' can acquire – or shift to – a disparate set of meanings like 'small,' 'pet,' 'imitation,' 'partitive,' 'affection,' 'exactness,' 'contempt,' and/or 'hedging' (cf., e.g., p. 542). This is the direct counterpart of the disparate expansions by which the elements and generalizations of phonology can become "unnatural" (as in Anderson's 1981 study of such phenomena).

In the case of allophones, the issue of origins has already been addressed often and at length by Ohala (1989, 1993a, this volume) and many others. It bears repeating, however, that Ohala's findings have increasingly focused on exaggerated reactions to percepts by listeners, rather than articulatory machinations by speakers. Thus (simplifying drastically), "hypercorrection" exaggerates the undoing of conditioned allophonic effects, while "hypocorrection" allows excessive acceptance of allophonic divergence as a prototypical phonemic target. Hence "this account of sound change is entirely non-teleological . . . [;] sounds . . . [do not] change in order to be easier to pronounce, to be easier to hear . . . [or] learn, or to . . . create any significant improvement or defect in language. . . . The only teleology . . . need[ed] . . . is that listeners do their best to imitate the pronunciations they hear (or think they hear) in others' speech and thus adhere to the pronunciation norm" (Ohala 1989: 191). Yet this last statement requires some minor rephrasing in order to accommodate the final sort of exaggeration to be discussed here: the fact that, while speakers always seem to orient their speech toward others' pronunciation, based on what they

perceive, there are circumstances in which their articulatory intent is to exceed the production of their models, in order to mark themselves socially through speech. It is this mechanism that gives the differentiation of allophones a persistence and a direction that can ultimately eventuate in phonologization.

4.2 *Phonetic distance via generational change*

In his summary of the results from his earlier fieldwork on Martha's Vineyard, Labov (1972a: 167) reported that successive generations of Vineyarders showed increasingly greater indexes of centralization for the diphthongal variables (ay) and (aw), as in *knife* and *house* – findings that were corroborated by instrumental records as well as impressionistic transcriptions. Generalizing from these and similar data, Labov characterized (p. 178) the third stage in the mechanism of sound change as involving “hypercorrection from below [the level of – explicit – social awareness]” (on hypercorrection in general, cf. Janda and Auger 1992): “Successive generations of speakers within the same subgroup [as the speakers originating the change], responding to the same social pressures, carry] . . . the linguistic variable further along . . . , beyond the model set by their parents . . . [, so that] the variable is now defined as a function of group membership and age level.”

The seventh and eighth stages of such “[sound] change from below” also involve exaggerations:

The movement of the linguistic variable within the linguistic system always le[a]d[s] to readjustments . . . of other elements. . . The[se] structural readjustments le[a]d to further . . . changes . . . associated with the original change. However, other subgroups which enter . . . the speech community in the interim adopt . . . the older . . . change as a . . . norm . . . and treat . . . the newer . . . change as stage 1. This *recycling* . . . appears to be the primary source for the continual origination of new changes. In the following development, the second . . . change may be carried beyond the level of the first change. (Labov 1972a: 179, original emphasis)

Similarly, in the view of Downes (1998: 237–40), the reason why sound changes tend to be generalized to new contexts – and extended in their effects – is that this constitutes the only way for younger speakers in a social group both to show their solidarity with older members (by sharing participation in the change via the use of common innovative forms) and yet also to set themselves apart (by extending the use of a variant to unique new contexts or degrees where it is not in fact phonetically motivated). This mechanism is persistent, directional, and incremental (it seems to be “continuous,” or at least gradual), and so it remains synchronically relevant for every speaker and generation that maintains a given phenomenon as an active sociolinguistic variable – thereby obviating the need for any ill-defined notion of transgenerational inertia to push matters along over time. In fact, Labov's (1994: 84) conclusion is that such “[g]enerational change is the normal type of linguistic

change . . . – most typical of sound change and morphological change” (cf. also the discussion in Janda 2001).

When such quantitative documentation of socially motivated exaggeration is deftly combined with psychophonetic research on the origins of phonological change in another kind of exaggeration, and viewed in the light of existing psycholinguistic studies of categorization (especially concerning phonemes versus allophones), the solidity of the conclusion that phonemicization/phonologization of an allophone can precede loss of its conditioning environment can hardly be exaggerated.

5 A Glance at Another Corroborating Case Study – and at Two General Considerations

5.1 *The Slavic palatalizations as another instance of early phonemic split*

In these days of impersonal Internet archives for linguistic studies, and personal web pages with downloadable papers, it is possible to consult numerous new works by some linguist without that person ever knowing who exactly has been copying and reading his or her research – and without readers ever feeling any polite compulsion or even slight inclination to reciprocate by sending off their own papers. Yet there can be a heuristic value to non-electronic snail-mailings of linguistic work, since they do tend to encourage reciprocity. Through just such an exchange, it recently became evident that advocates of the phonemicization-before-loss-of-conditioning approach (discussed above, in the previous section) are perhaps more numerous than one might think. For example, it turns out that Andersen (pers. comm.) has “always been of the view that phonemic differentiation must precede loss of conditioning” (an “opinion . . . greatly strengthened . . . [by] observ[ing] . . . children learning Danish and bec[oming] . . . aware how hard it is to know when conditioning is lost”). And, in fact arguments along these lines can be found in Andersen (1998: §3.2.1). One highly relevant passage is the following; at issue here is the “conditioning and progression of . . . [the so-called Second Velar Palatalization]”:

[T]he abductive innovation by which more strongly palatalized velars are phonemically dissociated from their less palatalized and non-palatalized covariants may occur at any time during the gradual process of palatalization. If, when this dissociation of variants occurs, velar allophones with different degrees of palatalization are distributed among different environments in accordance with . . . asymmetries . . . [such as, e.g., “velars . . . be[ing] palatalized . . . earlier next to high front vowels than next to non-high front vowels”], the result will be a conditioned phonemic split with phonemic reflexes of palatalization only in some of the environments in which velar palatalization is generally motivated.

Andersen (1998: §3.2.1) then calls attention to the relevance for Slavic palatalizations of the very same considerations involving phonetic distance – and, he points out, also “perceptual difference” – which were here discussed above in connection with German umlaut, since the distances and differences in question play a major role in abductive reanalyses:

If the (abductive) dissociation of variants occurs late in the deductive process, say after the assibilation of (some of) the palatal reflexes, it may be motivated simply by the perceptual difference between the palatal variants and the unchanged velars, and it may then occur despite the variants’ being in complementary distribution. But the dissociation will occur at an earlier time if the complementarity of the more palatalized and less palatalized velar allophones is disturbed.

One could hardly hope for a more direct convergence of views on the possibility – or, rather, the probability and even the necessity – of allophonic differences becoming phonologized (that is, phonemic) before their conditioning environment is lost.

5.2 *Two general considerations*

Before this chapter ends with a discussion of some – linguistically (especially diachronically) – suggestive conclusions, it seems appropriate to mention briefly two extremely general subjects: one of which relates to the title and major topic of this study, and the other of which bears on the issue of how much (if anything) of lasting value has been contributed to the study of sound change by works couched within the framework of classical generative phonology and its successors.

First, then, it bears emphasizing that, although phonologists (especially diachronicians) tend to talk about cases of phonemic split as instances of “phonologization” (as has also sometimes been done in this chapter), the emphasis placed here – and in Andersen’s (1998) above-quoted observations – on the dissociation of formerly conditioned, formerly allophonic phenomena from their earlier (more) phonetic conditioning actually reveals that we should think of so-called “phonologization” as in fact more as a kind of dephoneticization. Such a reconceptualization of one of the first stages in the reanalysis of sound changes (and in their – again metaphorically speaking – movement toward eventual petering-out) is then more in line with the fact that the various extensions and generalizations mentioned here typically involve exaggerations which are likewise less phonetically natural. These exaggerations involve principally (i) degree of phonetic effect(s), (ii) number and variety of inputs, and (iii) number and variety of environments, along with (iv) number and variety of sociolinguistic conditioning factors.

Second, it is difficult to forbear from commenting on the remark by Chomsky and Halle (1968: 322) that, “*if language acquisition were instantaneous, then . . .*

[their] model would be psychologically real.” But language acquisition is self-evidently not at all instantaneous, by any stretch of the imagination; the Chomsky and Halle (1968) model of phonology is thus clearly not psychologically real, and, most crucially, the consequences of these circumstances for generative historical phonology could hardly be less drastic and dramatic. To imagine language acquisition as instantaneous is to conceive of, for example, all forms in a paradigm or a set of related paradigms as being equally relevant to the establishment of underlying forms and to changes which might affect them. But psycholinguistic research has always found the opposite to be the case: certain forms within paradigms are encountered earlier than others (by children) or more frequently than others (by both children and adults), and this necessarily has an effect on real, mental lexical representations (cf., e.g., Bybee 2001 and references there).

Hence a theory which, like generative phonology, virtually always constructs lexical forms heavily on the basis of extremely marked forms – for example, late-learned and relatively infrequent words, such as future perfect subjunctives or extremely *recherché* derivational forms – has essentially done nothing but create underlying monstrosities whose alleged diachronic mutations (or, more often, whose diachronic persistence) will probably end up being cited only by historians of linguistics. Ironically, then, the very model of language which has prided itself on the phonetic naturalness of its rules and representation comes to grief as a diachronically relevant theory partly because it allows insufficient latitude for asymmetries, exaggerations, and dephonetization – unlike the approach advocated here. (On these and related issues, cf. also Cole and Hualde 1998; Joseph, this volume: n.10.)

6 Conclusion – Sound Change: Phonetics, Phonology, Sociology, or All of the Above?

What emerges from the foregoing observations about sound change – its inception, its spread, and its aftermath – is a model which can be likened to the “Big Bang” model of the origin of the universe.¹⁰ Using this, we can perhaps do something about the fact that – despite 125+ years of investigations into the degree of phonetic regularity in sound change, including Labov’s (1981, 1994) seemingly definitive demonstration that some phonological changes are sufficiently regular to count as “Neogrammarian sound change” – much about such “regular sound change” remains poorly understood. In particular, for any given change, we still have major questions concerning all of the following:

- i the range of conditioning factors typically relevant at the onset of the change;

- ii whether the same conditioning factors hold throughout the “lifespan” of the change;
- iii the sorts of alterations possible in the conditioning factors for the change;
- iv whether such alterations prevent successive instantiations from counting as the “same” change;
- v how long the change remains “active”;
- vi the validity of distinguishing (cf., e.g., Wang 1969; Labov 1972aff) the change’s point of origin from its spread/diffusion;
- vii at what point(s) in the lifespan of the change the purely phonetic conditions recognized by the Neogrammarians hold; and, more generally,
- viii the respective roles in sound change of phonetic, phonological, and soci(ologic)al factors.

On the other hand, it could be said that it is precisely these crucial issues which motivate a “Big Bang” theory of sound change. On such an approach, purely phonetic conditions govern an innovation at its necessarily brief point of origin (partially determining its future trajectory), but they are rapidly supplanted by speakers’ imposition of phonological and sociolinguistic conditions (deflecting the future course of the process). Insisting on the obligatory early presence of finely detailed phonetic conditioning explains why regularity holds: purely phonetic environments guarantee that a change is applicable whenever the most general type of conditions are met – and thus why grammatically or functionally based exceptions are absent from this stage. We are also less likely to confuse actual phonetic innovations with mere diachronic correspondences (for related discussion, cf. section 1.2.1 of the introduction to this volume) if, from the outset, we manage to focus narrowly on the fine phonetic conditioning of sound changes, rather than bringing into our purview any two symbols which can be written on opposite sides of a “greater than” sign.

This approach can be supported by detailed (re-)examination of two relatively well-known changes – Romance *e*-prothesis in *sC*-clusters and Swiss German *o*-lowering – and of one relatively neglected contemporary change – *s*-retraction in present-day American English clusters like #str... / ...r#st... (for much more detailed discussion of these cases, see Janda and Joseph 2001).

Regarding the prothesis in Spanish *escuela*, French *école* (from Latin *schola*) ‘school,’ and the like, very few handbooks (excepting Lausberg 1960; Lloyd 1987) mention its original phrase-level conditioning – that is, ...C#sC..., not just #sC... – which survives in formal written Italian (contrast *la Svizzera* versus *in Svizzera* ‘the/in Switzerland’). Here – for example, in Spanish – dephoneticizing generalization has minimized the once purely syllable-structural basis for prothesis by making it crucially dependent on word boundaries (which are, per se, arguably a grammatical construct).

As for the preconsonantal *o* > *ɔ* change in northeast Swiss German: though lowering originally occurred only before *r* (/__r), most dialects (cf. Keel 1977b) now lower before a disparate range of consonants. Hence dialects with, for example, lowering before all obstruents except *b* show generalization via

simultaneous phonologization and dephonetization – and for social reasons: villages exploit Labov's familiar mechanism of overgeneralization ("hyper-correction") to establish their identities.

Finally, increasingly frequent pronunciations like [ʃ]trand/under[ʃ]tand, despite their fragmented and sporadic nature – or precisely because of it – show early, pre-generalization, stages, but with a nucleus of phonetic conditioning rapidly undergoing expansion and showing regularity on what could be called a localized particularistic basis.

Viewing such case studies from a "Big Bang" perspective allows a start toward definitive answers to the above phalanx of rather difficult but nevertheless crucial questions. In its purely phonetic manifestations, sound change is indeed ephemeral (though it is fully regular within very narrow bounds), since it rapidly yields to generalization along non-phonetic (that is, along phonological or morphological) and/or social lines, with these latter developments then in turn allowing for further regularity via extension to broader contexts. The Neogrammarians were thus mainly right about sound change, but not exactly as they or Labov (1981, 1994) envisioned.

NOTES

- 1 Cf., for example, the borrowing of the Latin name *Patricius* into Irish as *p*-initial *Padraig* 'Patrick' – even though, at an earlier stage, Latin loans with *p*- were borrowed into Irish with *c*- (the spelling for [k]), as demonstrated by the early form *Cathraig*, also from *Patricius*. The fact that Irish speakers at a later stage could borrow *p*-initial Latin words without altering their initial consonant shows that the consequences of the earlier loss of **p* did not actually have a permanent effect on the Irish phonological system.
- 2 The use here of organismal terminology like "lifespan" is not really at odds with the anti-organismal stance taken by Janda and Joseph in the introduction to this volume, since the use of life-related terms in this chapter is to be seen as completely metaphorical. In parallel fashion, Janda (1987) discusses the "life cycle" of sound-structural rules, but that work explicitly lists many ways in which the transmogrifications of originally allophonic generalizations across numerous generations of speakers and sometimes numerous centuries are unlike the lives of biological organisms.
- 3 See section 1.1.1 of the introduction to this volume for some discussion of certain consequences that result from ignoring or even just suppressing morphology.
- 4 See Janda (1998b), as well as Janda and Varela-García (1991), for brief discussion of the English *a/an* alternation and also of other, somewhat parallel cases that involve either articles in Spanish or demonstratives, possessives, certain adjectives, and some prepositions in French (on the former of these – i.e., Spanish articles – see also the concise

remarks later regarding so-called “feminine” *el*).

- 5 The alternation of *my/mine* (and, similarly, of biblico-archaic *thy/thine*), while it is historically parallel to *a/an*, is now syntactically conditioned, with *mine* occurring in predicative position and *my* in attributive position; hence *my* versus *mine* is no longer parallel to *a* versus *an*.
- 6 This particular point has been forcefully made by Joseph (1997, 1998).
- 7 Holman (1985) in fact argues that the process in question has been semasiologized: that is, that it has gone beyond morphologization.
- 8 Purely for ease of exposition, the treatment here omits most discussion of the High German unrounded vowel changes of short /a/ usually to [e] (so-called “primary umlaut”; cf. the recent discussion by Janda 1998a: 173–4) but sometimes to [æ] (“secondary umlaut”), and of long /a:/ to [æ:].
- 9 The philologically trained European structuralist Valentin Kiparsky (1904–83) thus made a seminal contribution to historical phonology long before pioneering generative work was carried out in the same field by his son, (René) Paul (Viktor) Kiparsky (cf. P. Kiparsky 1965ff).
- 10 This model and its associated terminology were introduced by Janda and Joseph (2001).

Part IV
Morphological and
Lexical Change

This page intentionally left blank

10 Analogy: The Warp and Woof of Cognition

RAIMO ANTTILA

Greek science was based on an analogical grid of a contiguity axis (also known as causal, or indexical) and a similarity axis. Thus Aristotle defined genera in the way shown in figure 10.1 (Hesse 1966: 61; this has often been quoted, e.g., Anttila 1977: 18; Itkonen 1994: 44; Itkonen and Haukioja 1996: 137).

Lining up secure similarities gives an anchor for going into the uncertainties (the dots in figure 10.1), especially if there is an imbalance (figure 10.2).¹ This is still the essence of scientific analysis (and everyday perception and understanding). Note how water waves led to sound waves to light waves, and so on (Hesse 1966: 11, 68, 93–6). There are positive and negative analogies that build up explanations, but particularly useful in everyday life is persuasive analogy – for example, the state is to its member as a father is to

SIMILARITY | WOOF

C	<i>BIRD</i>	<i>FISH</i>	W
O	wings	fins	A
N	lungs	gills	R
T	feathers	scales	P
ig	.	.	
ui	.	.	
ty	.	.	
	.	.	

Figure 10.1 The structure of analogy

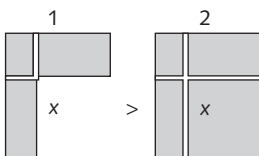

Figure 10.2 Gap filling

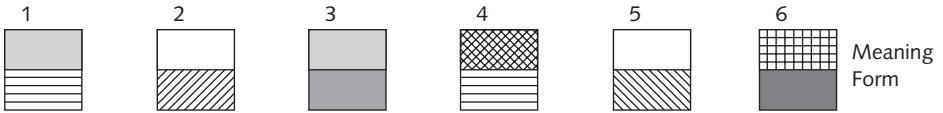

Figure 10.3 Meaning and form

his child – and such analogies are the essence of cultural networks and mythologies (there is nothing else, in fact).² Analogy mediates between actuality and potentiality.

The two axes in the analogical frame (reflecting a proportional relationship, an expression of similarity of the sort $A : B :: C : D$) cover any kind of material where we have similarity and contiguity. In figure 10.2, we have on the left two axes which share the top left corner unit. There is a gap x that calls out to be filled by analogy; this has happened on the right, with the box x . This situation is usually given with numbers: $4/2 = 10/x$; $x = 5$, and no problems arise, since we get exact results (identical relations). But with most material fed into such structures we have to be happy with vaguer similarities (in other words, the similarity stretch between x and x [$>$] can be a long gradient scale = drift). Note that the left–right sequence in figure 10.2 succinctly summarizes analogy’s two great theoretical powers. First, it shows that analogy is the agent that dives into the hermeneutic gap, the *átupon*, the ‘out of place,’ the strange, the problem that asks to be explained or solved; second, at the same time it is an impelling force of closure in gestalt terms. In such structural asymmetry perception strives for wholeness. Thus, hermeneutics (pattern explanation) and gestalt theory work under the same laws of human understanding. We also secure imposing metatheoretical glory for analogy, although we just generally see its practical application value.

When it comes to linguistic signs – and let’s just say words at this juncture – we have to remember that they are combinations of form and meaning (again simplifying the situation to a Saussurean colligation). Incredible mistakes are committed if only form is considered, and thus analogy seems to fail (but it is the linguist who has failed; cf. Itkonen and Haukioja 1996: 135). Similarity relations exist both in meaning and in form, and meaning and form are combined in the symbolic colligation. Observe the six such colligations in figure 10.3, say, where the squares represent words. The top part of the square represents meaning and the bottom form. Words (2) and (5) share the same meaning, and (1) and (4) the same form. Various degrees of similarity can also be perceived (figure 10.4). Thus a figural set-up with identical form would work toward changing meaning (1) toward meaning (4) or vice versa (the diagrams again emphasize identity), or with (2) and (5), the forms could go either way. The actual forces depend on the centrality of each feature in context, culture, grammar, and so on. Numbers (2) and (5) could also portray allomorphy, as could (y) and (z), since the lexical meaning is identical, and in this situation contamination (y, z) is also normal.



Figure 10.4 Similarity relations

The force here has been described (see, e.g., Anttila 1972), in a way used ever since the Ancient Greeks, as “one form–one meaning” (although this particular characterization is mine, as well as the notation below), an ideal in sign formation that of course will never be achieved, but the ideal pushes constant change (cf. Anttila 1977: 55–8, 1989: 100–1, 107, 129–30, 143–6, 407; Itkonen and Haukioja 1996: 162). The main force in such change is analogy, as rationality, of course. What this principle says is that the configurations **V** (two meanings – one form) and **Λ** (one meaning–two forms) tend to be leveled out to **I** or split into **I, I**. (Then of course metaphor, metonymy, loan translation, and folk etymology again create polysemy **I > V**.) Allomorphic alternation, **Λ**, as in the original *shade/shadow*, or *cow/ki-ne*, tends either to split into independent words **I, I** (*shade* and *shadow* with different meanings) or to get leveled out into **I** (as in *cow/cow-s*). Extension of alternation from a more restricted environment to practically every word as in Lapp/Saami consonant gradation, **Λ, I > Λ**, still represents unity for diversity. Leveling and extension remain as the most prevalent analogical change concepts.

The situation (1, 4) in figure 10.4 is so-called homonymic clash, and if change occurs, formal differentiation is expected. Keller’s treatment of German *englisch* ‘angelic’ and *englisch* ‘English’ is a good example (1994: 80–3, 93–5, 124, 132, 156). In a context like *englische Mädchen* the conflict was insidious, and the first one was replaced by *engelhäft*, restoring one meaning–one form. The identical base morphemes need not be perceived; the sign is normally taken as a whole. But any feature perceived and any interpretation successfully forced on a percept is a potential anchoring for analogy. Thus French *cerise* > *cheris* was interpreted in English to have the pl. -s, which then necessitated a new analogical sg. *cherry*. Similarly Arabic *kitabū* ‘book’ in Swahili was interpreted to contain the native noun classifier *ki-*, whereby the plural had to manifest as *vitabu*. Such examples are commonplace (latest treatment in Itkonen 1999: §III).

These figural form–meaning colligations appear everywhere in language structure and use. Consider borrowing, perfectly analogical. For example, note the following situation between American English and Finnish as pertains to certain “tools of smudging,” forming thus a general semantic similarity field of something like this articulation:

brush		pencil	⋮ E
harja ‘brush’	pensseli ‘paint brush’ ↗	lyijykynä	⋮ F

This kind of different partition of semantic fields is typical between languages, and it does not matter that *lyijykynä* ‘lead-pen/quill’ is motivated. The relation here between the two languages is roughly Λ/I (with the slash indicating the formal similarity (the arrow) in *pensseli/pencil*). In American Finnish however, where English is an extremely strong social force (the necessary indexical anchoring for analogy), it exerts the one meaning–one form pressure on Finnish. Since *pensseli/pencil* is a formal match, it is kept, but with English semantics, whereupon *harja* takes on the whole range of English *brush*:

brush	pencil
harja	pensseli

The result is greater one-to-one unity, both in form and in meaning, between English and American Finnish (i.e., $I I$). This is quite common in (American) immigrant situations; for example English *like* (1) ‘similar/equal’ and (2) ‘to be fond of’ versus German *gleich(-)* (1) has yielded Pennsylvania Dutch (2) *ich gleiche dich* ‘I like you’. Similar examples could be multiplied by the thousands.

1 Definition of Analogy

The above was of course quite general, but sufficient; largely the proportional aspect was treated, hinted at with language material. Now when the basic structure has been laid out, we can add a basic definition: analogy is a relation of similarity, that is, a diagram (in the sense of Peirce 1965: vol. II, with warp and woof). In other words it is structural similarity (Itkonen and Haukioja 1996: 157; cf. Holyoak and Thagard 1995: 208). A diagram is the central icon, central in any science. But it is central in perception and cognition also, because if we would just rely on images (i.e., mere pictures of feeling-similarity), we would not get anywhere (not out of our own heads, although we would not even know it). A diagram gives us a reasonable map of reality pointing toward further knowledge. All this is heightened with the higher-order diagram, the metaphor (which I try to avoid here for reasons of space).

The proportion brings out the relation quite nicely and convincingly (for most linguists). It can be said that the faculty to analogize is innate, and language faculty falls under this imperative. More generally one can say that we have here a relation between a model and a copy, and the copy can be quite blurred (or in other words: mapping knowledge from one domain into another: Itkonen and Haukioja 1996: 137). In language it has been quite comfortable to espouse the proportion (Paul 1880), but one needs the other end also (from Hermann 1931 to Winter 1969; see Anttila 1977: 72–6).³ The ability to copy is enormously

powerful, as seen in language learning, or any learning, in the social context (Short 1999). Thus it is no wonder that linguistic signs can also be copied and modified, lifted out of their original contexts. Note that in science we end up with theoretical terms that are stipulated (“not seen”), whereas in language the new items pop out immediately for approval (whether they get approved is another matter). There is no difference in the analogical structure.

2 Transposition and Analogy

All cognition is based on relation and order, that is, *gestalts*. Gestalt is ultimately based on relations, because it is the total relation of relations (Weinhandl 1960: 132, 166).⁴ The most crucial concept in all this is that of transposition: *gestalts* are invariants of transpositions, similarities of correspondences. “For whatever one would mean by *gestalt*, the *transposability of gestalt* has to be taken as its essential property, as already von Ehrenfels tried to show” (Kaila 1945: 65; below Kaila’s emphasis is eliminated). “We have verified that one essential side in symbol function is connected with intermodal transposability [and add analogical extension]. Here one sees the connection of symbol function with *gestalt* formation” (pp. 65–6). One has to assume that “the organs forming the *gestalts* reach the invariants contained in the multiplicity of receptor excitation. I call the principle in this assumption the principle of invariance of perception. ‘Invariants’ mean here the unifiedly recurring relations in the different areas with a multiplicity of excitation” (p. 86). “Thus the process of consciousness is from beginning to end a search for invariants, finding them, and partly also creating them” (p. 89; my translation). Transposition holds the key role (Weinhandl 1960: 406–12) in connection with invariance, isomorphy, language, natural law, and constancy. When a factor (structure-point) varies, matching covariance of other factors produces invariance (p. 406). Transposition is crucial for our experience, memory, and cognition, and it presupposes recognition (p. 407), since we have to recognize a structure in other materials. In the symbolic mode (verbal, graphic, numerical) we get categorization in that we assign facts to recognized concepts, thereby getting an isomorphic representation for the object (one meaning–one form; Shapiro 1991). Transposition thus provides (in immediate experience) an isomorphic replica (Kaila 1945: 407); similarity is again central (cf. pp. 206, 408).⁵ If we could not experience similar structures or figures or facts, we would really have nothing. It is constancy that gives another match to invariance of objects (as experienced or perceived), and thus fills another aspect of phenomenal representation (p. 411). This is how we get a constant external world and a chance for a fixed starting-point (e.g., for analogy). This is, again, how we can further explain the human mechanism for fiction and hypostatization. More particularly, we see the immediate reasons for the necessity of epiphenomenal meanings (grammatical meaning, metaphor, riddles, and the like).

We have again reached the concept of analogy, although it might not be apparent to all linguists. The step from transposition to analogy can be best exemplified by the fact that our perception grasps the world through complex formation (perception of wholes) and abstraction (Dörner 1977). Our concepts are relational stencils that classify incoming information. Gestalts and super-signs are characteristically of the structural kind, since their composition can be transposed into other media or units (p. 74). A structure or configuration of relations establishes a gestalt, and since the relations are not contained in the parts of the whole, but obtain between them, a gestalt is indeed “more than the sum of its parts” (p. 75). As for transposability, Dörner states that it is nothing but the possibility of interchanging the components of a structure with others. The gestalt principle is simply a structure of empty slots for the components (pp. 75–6). Finally, Dörner shows how argument from analogy consists in (i) matching a known domain of reality with another structurally similar one, in (ii) abstracting the structure, the gestalt from the known, and (iii) putting this structure over the unknown area. “An argument from analogy is an attempted transfer of a structure from one domain of reality to another” (p. 81). This is critical analogy, but the same holds for what we know from language, and this is what philosophers, psychologists, and scientists have come up with time and again. Gestalt principles give a solid philosophical foundation for analogy and inference in general. Analogy, as used in traditional linguistics, is perfectly valid. Whatever its limits are, they cannot be rectified or eliminated by denying the notion altogether, since it is all we have (cf. Holyoak and Thagard 1995: 148, 262). Further, it is no use trying to formalize it for “proper” explanation, as linguists wanted to do during and since the 1970s. Harald Höffding (1924: 26) already analyzed concepts like analogy and symbol as correlative concepts expressing a mutual relation. Höffding took synthesis and relation as correlative *categories*, exactly like continuity and discontinuity, resemblance and contrast (difference). These are *fundamental* categories; analogy is *formal* (cf. Itkonen 1994: 52), and totality *real*.

In short, similarity is the most important holistic process in mental life. It is the basic axiom for all cognition, and since we are dealing with similarity we have here a continuity agent between percepts, parts, and even sciences (Höffding 1924; Anttila 1977: 5). Models of formal logic fail, because analogy does not fit into their either-or tallies. Note that Leibniz already pleaded for *topology, analysis situs*; such notions have been rediscovered in cognitive linguistics (see Heine and Traugott, this volume), curiously tied with metaphor, not analogy.

In fact, rationality is a process of becoming from indeterminate vagueness, and thus change is a primary aspect of reality (Shapiro 1991: esp. §5). The use of symbols involves their further determination and this necessarily leads to change. Language use is largely problem-solving in communication (including its many-faceted context) and thereby falls under rationality, since one cannot solve problems without any reason. Language use falls likewise under emergence phenomena in which structure and becoming cannot be separated.

And indeed, analogy is the main force in language structure, and it is an agent of change. What has confused many is that similarity/analogy works both in structure, giving it cohesion, and as a process for problem-solving (Itkonen 1991: 313–20, 1994: 44; Itkonen and Haukioja 1996: 136, 142). This is traditionally well understood, although since the 1960s both aspects have been badly blurred, apparently both on purpose and by accident.⁶

3 Analogy and Metaphor

The two crucial factors in any relevant conception of cognition, namely similarity and contiguity, come out in (cognitive or otherwise) linguistics as metaphor and metonymy. Of course, today the Peircean terms iconicity and indexicality also abound, particularly the former (see Anttila and Embleton 1995: n.9). Now there is no end to the literature on metaphor, and often no indication is given that the notion was quite well understood before.⁷ Something like this was bound to happen, since Chomsky's denial of metaphor as a relevant thing and the rejection of analogy by the whole school was startling incompetence. Of course formalists and those sympathetic to them say that explaining everything with metaphor does not explain anything.⁸ In principle there is no difference between metaphor and analogy for our purposes.⁹ It was a mindless coup in linguistic theory to abolish analogy in the face of its long tradition in linguistics and philology (although its reintroduction in Optimality Theory has now made some linguists revolutionary).

The problem with analogy seems to be the following: against the nice dualities like similarity ~ contiguity, metaphor ~ metonymy, icon ~ index, abduction ~ induction, which all match, analogy is a mixed bag; it mixes the two columns, as it were. Since the context (the warp) is so crucial, I have called analogy an indexical icon (Anttila and Embleton 1995: 98). The contiguity aspect of analogy (nearness) is also emphasized by Coates (1987: 337). Locality is again central in cognitive psychology and linguistics, and this is true of analogy also, since it requires orientation as a crucial anchoring factor (Vaught 1986: 324–5; Haley 1997). In current cognitive theory the prototype gives the orientation point, and then metaphor carries it further. Note that this is exactly what the Ancient Greeks had in their paradigm (example) and analogy (proportion). The paradigm is the indexical part.

Cognitive linguistics has got great mileage out of body metaphors, here too ignoring earlier work (Anttila 1992a: 66). The body is also central in the problem of foundational analogy, or incongruous counterparts, in orientation (right and left) (Vaught 1986: 314–16, 325–6; see also Haley 1997 for foundational analogies). Finally, whether we accept it or not, it is constructive to remember Vaught's plea for an analogical relation between the immediate and the dynamic object and the two interpretants (1986: 321). Analogy joins them, but also keeps them separate (distant). Meaning is thus perfectly analogical.¹⁰

One defense of metaphor in cognitive linguistics is that semantic field theory would not be able to shift between fields, whereas metaphor offers such a possibility (cf. Anttila 1992a: 66). This is strong camouflage, since analogy was always taken as giving this ability (Höföding 1924: 72; and others).¹¹ There is no difference between analogy and metaphor in this context, and we have seen how analogy performed exactly this service (transposition; Dörner 1977).

4 Leaking Syllogisms

Among the first to combine analogy with abduction was Anttila (1977), but now this is becoming more matter of fact, for example, in Thagard (1988), for whom, by necessity, as we now know, analogical inference involves similarity and causality (pp. 60–5, 165). Past solutions are crucial for new problem-solving, in other words, experience in context. Although analogy mixes induction and abduction, no harm is done, because in historical explanation we need just that. This is also the situation in the computational paradigm in which problem-solving must be tied to induction (Thagard 1988: xi, 15, 19, 26, 70, and particularly his diagram: 28, which shows that in his system induction feeds into abduction), abduction (pp. 52–60), analogy (22, 24, 92–5), or analogical abduction (60–2). What all this means is that analogy is crucial in any science; it improves explanations within theories and supports hypotheses already discovered (pp. 92, 94–5). Since analogy goes from individual to individual (Aristotle; Thagard 1988: 95; Melis 1989: 89) it is particularly handy in any real or historical context. It also supplies a frame for holistic thinking (Melis 1989: 89), or is in fact holistic and analytic at the same time (Haley 1988: 6). Analogy can be taken as an inference that leads to a solution of a problem, thus mixing abduction, induction, and the practical syllogism, that is, perception and experiential context as premises (necessary conditions) lead to interpretation as conclusion (cf. Melis 1989: 96). Time and again it comes out that analogy is an agent of closure (Melis 1989: 89), and only its strictest forms are formalizable, otherwise the human is necessary (Melis 1989: 98–9; Coates 1987: 321, 319, 336), and in fact we need key words even in computer programs (Melis 1989: 104). The human is necessary, because that is where experience and the true analogical ability reside (this is *de facto* another strong plea for hermeneutics). Also Thagard's program PI (= process of induction) requires background knowledge stored in concepts, and uses a goal-directed component (p. 29), and schemas over propositions (p. 31), concepts over rules (pp. 38–9; Coates 1987: 320, 337). No wonder formalists are unhappy. As for metatheory and for treating change, they are also wrong. To put the issue in a nutshell in this context: traditional analogy, as manifested and known in historical linguistics, was and is right (cf. the "proportional" schemas in Thagard 1988: 93; Melis 1989: 90; Holyoak and Thagard 1995: 95).

At this juncture it is good to remember that analogy is indeed often equated with induction (Itkonen 1994: 45; Itkonen and Haukioja 1996: 132, 140) – and

correctly so. But induction has a bad ring to many theoreticians, and maybe this is why many push metaphor, if they can ignore the equation of metaphor with analogy.¹² Ignorance is no help in anything but one's piece/peace of mind. But of course the metaphor cannot do without an indexical launching pad. Haley points out that there is a powerful interactive index in metaphor:

This indexical component of metaphor is . . . its clash of dissimilars. . . . Like a red flag, another Peircean example of the Index, the semantic shock of a novel metaphor is what brings it into the foreground of perception. Or we might say that the figural tension of the metaphor is the indexical "smoke" which "points" (the first function of any index) to the metaphorical "fire." (1988: 14)

This kind of index forces something to be an icon: "meaningful metaphorical tension is that kind of index which *contains* an icon, as a photograph reliably 'points' to the object represented by its iconic image" (p. 15). Such indexical interaction (p. 53) is crucial throughout. An index in this mode shapes its object and becomes "something of an icon in itself" (p. 135; cf. p. 98), which is also true of assimilation in sound change, it would seem. "[W]hat identifies something as a candidate for interpretation as metaphor is species opposition, for it is this that provokes the search for a figural icon, its object, and their similarity. If this search is successful, the utterance is confirmed as metaphor" (p. 100; note transposition and closure again). "[I]t is the metaphorical index that is forever forcing us to understand and appreciate the proliferation of semantic species" (p. 151). Throughout his book Haley shows that when the iconic content approaches diagrammaticity or analogy the index is also enhanced, suggesting more imaginative possibilities (p. 161; cf. also pp. 22, 33, 56, 78, 84, 143); in fact he "believe[s] diagrammatic thought must have been the breakthrough which crystallized the differentiation of semantic levels in language and consciousness" (p. 153). In other words, we see that analogy/metaphor is an agent of closure, filling the *átopon*, and thus there is a new place.¹³

The inductive attention-arousing indexical gap in the diagram is of course "the initial problem" on which perception and abduction feed (major premise: "The surprising fact, *C*, is observed", from Peirce; e.g., Anttila 1989: 404, 1992b). Treating English place names, Coates (1987: 330) "suggests that the parameter of relatedness is distance apart, literally the distance on the ground – or the sea – between them" and uses this to explain analogical reformations. The distance can come from a mental map, of course, but "nearness is the spatial expression of, and is prototypical for, the relation of similarity" (p. 337). This is another convincing case of the index working itself into a kind of icon along the lines Haley suggests for the metaphor. Spotting such a tension or gap is of course an invitation to solve the problem, that is, it is an imperative to action, and such action propels change, in fact and by definition, whether we want definitions or not.¹⁴

So, whether we take our path through metaphor or any of the leaking syllogisms (abductive, practical, actionist; see Anttila 1992b), we are led to fallible situations (cf. Holyoak and Thagard 1995: 209), but these situations are the only

ones that lead to new knowledge and solved problems (which then immediately create new problems; Short 1999). This is one reason Peirce called abduction and induction ampliative inference. It is the reason too why prediction and formalization are really of little use. This is the traditional position. It is also the position people come back to, again and again, whether with new terminology or not. Note in this context van Wolde (1996): she rightly emphasizes the analogical element in Peirce's logic, although he himself dropped it later (in name at least). She pleads for a combination of induction, abduction, and analogy, since all are inferences from sampling. Abduction (possible to general) makes a leap for a possible truth, induction (actual to general) does not secure certain truth either, and both are analogic in nature (Peirce's ampliative inference). Nothing in substance seems to have been added; it is the old names game again. Van Wolde concludes: "So far, however, no analogic has been set up and its elementary value for the solution of problems is not as yet fully taken into account" (p. 348). This sounds baffling, because Vaught (1986) went a long way on the high theory side, and in fact such a logic has been standard in linguistics for decades (note analogy as an indexical icon in Anttila and Embleton 1995). Note that even deduction (van Wolde's logic) needs analogy to be learned! When she uses analogical inference to transpose experience into cultural codes, and then these codes into behavior and action (p. 346), she is applying analogy according to Ancient Greek science (and current folk mythology). There is indeed transposition between fields or domains; this comes out and has come out at every turn, now and in history (cf. Holyoak and Thagard 1995: §§7, 9).

5 Measuring and Classifying Analogy

What is extremely important in this is the role of indexicality. Of course, ever since Saussure (and beyond) association has represented it (see also Esper 1973 from the psychological point of view), but analogy asks for indexicality as ascribed (assigned) similarity. On this basis Coates can give a typology of motivation for analogical reformation (if change takes place) (1987: 333–4). Such a typology must indeed be based on somehow measuring the interlocking of similarity and indexicality. As already mentioned, the difficulty is that contexts and percepts cannot easily be given or defined in advance. This is why the usual classificatory schemes of analogy are not very useful. They try to give in advance what the dynamics are and what comes before and what the result would be. The most famous case of such classification attempts is the "controversy" between Kuryłowicz (e.g., 1945–9) and Mańczak (e.g., 1958, 1980), portrayed succinctly, for example, by Best (1973: 61–107; cf. also Anttila 1977: 76–80), and most recently "tested" by Salm (1990) through verbs (see also Hock 1991: chs 9–11; Winters 1995; Hock, this volume). Roughly, one can say that Kuryłowicz looked at the issue from the point of view of grammar, sphere of employment, qualitative relations, and proportional analogy, whereas Mańczak

has concentrated on frequency and statistics, quantitative aspects, use in actual context, attacking the proportional formula. All this mixes up abduction and deduction in that the emphasis has been on diachronic correspondences, between before and after, rather than looking at the analysis of change itself. All commentators seem to agree that Mańczak fares better (granting that the questions posed by the two are often somewhat incommensurate). Kuryłowicz has done best with his fourth law (that the new form takes on the normal unmarked function and that the old one gets special readings). Of course, the two forms must both be attested (e.g., *brothers/brethren*, *mouses/mice*, etc.), and *mouses* is hardly the unmarked “normal” form. The upshot is that neither (or no linguist) is able to nail down all changes or to predict them, and in this Hermann Paul fares quite well, since he said (1880: 208) that we would have to be omniscient to do that (Salm 1990: 170, 172). Paul, the great defender of the proportional view of analogy, keeps on coming out right (Wurzel 1988; Itkonen 1999). The practical result of analogical change classification is thus that the non-proportional configuration wins out as the essence of the similarity–contiguity vectors (the Hermann/Coates line, as it were), although the (“universal”) Paul proportion gives the best immediate conviction.

The direction of analogical change remains a problem, especially if one wants to predict it. Any direction can apparently be reversed in the right situation (Vennemann 1972b; Becker 1990). The best results have been achieved within natural morphology, where one maintains, largely with justification, that changes tend to go from marked to unmarked forms (see Mayerthaler 1980b; Wurzel 1989; Dressler, this volume, for further references and discussion). Then, of course, there are problems in interpreting markedness; and social aspects can override language structure.

The main reason why classification of analogical changes is not so interesting or useful is that similarity cannot be predicted in advance. It needs the total context as the background.

6 Recent History in Linguistics

Linguistics has traditionally been based on analogy, both synchronically and diachronically. This has been clearest in morphology, which tends to have analogous paradigms for its inflections. In the Ancient Greek terminology, analogy was the regularity observed and paradigm was the example provided for its application or manifestation (cf. a modern application in Malone 1969). This combination gave the basic notation for handling grammatical facts, and it was in fact quite good, because analogy has been and is always used when the object of study is not directly there. We do not observe grammar directly. A basic split occurred in linguistics when generative grammar rejected the notion of analogy in the early 1960s, maintaining that there is only underlying phonology and phonological rules. It is still difficult to see the rationale behind

this, because it is analogical for two reasons. First, the historical model was analogically imported into synchrony; second, analogy was further used for positing underlying forms in borderline cases. When the tense/lax alternation in pairs like *divine/divinity*, *sane/sanity*, etc. required uniform long or tense vowels on the historical model, this result or knowledge had to be extended into the new unknown domain of, say, *boy*. Here adherents revel – and opponents reeled – at such an extreme application of the generative phonological method with the positing of a systematic phonetic (underlying) form /b \bar{x} /. Such an analogically established form proved now that analogy does not exist, or is at least seriously inadequate, with the concomitant claim that this was the only underlying form with psychological reality in English; a singularly unconvincing claim, since English speakers have great difficulties in producing front rounded vowels. The non-existent analogy was a great molder of theory in the positing of underlying forms (which were things, not relational points), but when it came to the playback mode, analogy could be discarded.

Note that the acceptance of such a theory is also analogical: once this theory became fashionable (and we know that anything can become fashionable in the right social conditions), it became a feature, shibboleth, or emblem to be imitated. We have the two factors of the analogical frame: (i) the indexical identification of this theory with contemporary prestige and future success, and (ii) the similarity extension of this feature to (or acceptance by) the scholar who wants to belong. And most linguists wanted to belong, because it was not only that prestige was involved, but also that the theory secured the best and best-paying jobs. This kind of situation is the standard structure in the adoption of youth gang emblems, etc. And such social factors are also the strongest forces behind the adoption of any language features, including sound change. The same is true of the social aspect of sound change: Speaker₁ uses Sound₁ in Word₁, and I use something else. If Speaker₁ has prestige for me I might consciously or unconsciously want to imitate him or her and adopt Sound₁ as an index of him or her or his or her class, exactly as I might copy his or her clothing style as another index. I myself assign myself (consciously or unconsciously) to Speaker₁'s class as a potentially similar member; thus it is again ascribed/assigned similarity, but that does not matter; it is strong causal similarity in human action. We want to be stamped with the same die. This social aspect of change is quite obvious and well known in dialect geography, either social or areal, and can be left out in this context.

Regular sound change has the same analogical structure: when a sound changes in Word₁, or Group₁, it also changes in Word₂, and so on (= clear proportion). This is exactly how regular sound change proceeds from group to group and category to category, however they be defined in the particular case. The similarity vectors are usually identical sound environments or conditions, but can also be semantic or grammatical (see Hock and Hale, this volume). Such semantic–formal similarity is indeed what belongs to the essence of analogy whatever the units are that are fed into the grid (cf. Coates 1987). Ever since the mid-1800s distinctive features have been portrayed analogically:

$p/b = t/d$, etc. (this is the static structure mode), but then (in the structuralist era) gaps in the phoneme inventory could be expected to be filled out analogically (in the dynamic process mode). New phonemes came about, but not new distinctive features (see Leed 1970).

In the 1970s I was busy mapping the generative treatment of analogy (as delineated above). The first phase away from mere phonological rules (for them) was bringing back the analogical morphological paradigm, but under terms like distinctness conditions, leveling conditions, paradigm coherence, etc. (Anttila 1977: 98–110). More recently the watch was taken over by Esa Itkonen, whose output is an excellent survey of the current scene. He has run the gamut from extralinguistic reality to language (thing/action = noun/verb) and then language structure alone (Itkonen 1994). Particularly important now is Itkonen and Haukioja (1996), because it shows that a computer program can be written for syntactic analogy, contrary to the theoretical claims by generativists. Analogy is indistinguishable from the traditional substitution test (Itkonen 1994: 49). Thus *John / ran away* is identical in structure to *My oldest brother / has bought a new house* (NP-1 / VP-1 = NP-2 / VP-2). Narrowing one's focus into mere physical similarity, as, for example, in Chomsky's *boy / boys = enjoy / enjoys*, refutes the very structure of language (just the form part of signs in figures 10.3 and 10.4 above). An innate principle is needed (for generativists) to tell us that *Mary* is the subject in *Mary bought a dog to play with* (Itkonen and Haukioja 1996: 161). Analogy with *Mary bought a ball to play with* would have given a better answer straight, and furthermore, appeal to innatism means giving up on explanations altogether, as Itkonen has been stressing. In analogy one uses known cases to understand new or unknown cases; there is no mystery.¹⁵ Analogy does exactly what might be considered impossible. Similarly, Paul Kiparsky's newest name for analogy, viz. optimization, continues the line of creating new labels that sound theoretical and innovative (Itkonen and Haukioja 1996: 162–3). One can note that a gradual increase in regularity and system cohesion is a typical inductive matter, and on this feature alone we see that analogy lurks there. Finally, in their treatment Itkonen and Haukioja scrutinize Jackendoff's representative work, and show that the latter's headed hierarchy, cross-field generalization (for metaphor), and preference rule systems all fall under analogy. "Although Jackendoff makes no attempt to formalize his 'preference rule systems', they have been hailed as a major discovery" (1996: 166). What was not allowed for analogy is freely given to these disguised and distorted variants. Higher and higher-level generalizations are a respected goal in any science, but here generative linguists go the other way; still – after all these decades.

Itkonen and Haukioja list six important implications from their work on analogy; chief among them is the following (1996: 167):

Analogy refutes the modular conception of mind, in two complementary ways. The view that language is a mental module entails that it is "encapsulated" both vis-à-vis extralinguistic reality and vis-à-vis other modules. Iconicity (as an exemplification of the static analogy) shows that language is not "encapsulated,"

because perceptual structure (causally) *explains* linguistic structure. Analogical inference or generalization (which represents the dynamic aspect of analogy) is a cross-modular process which applies equally to language, vision, logic, music, etc. and shows, *eo ipso*, that language is not “encapsulated” vis-à-vis other modules.

Jerry Fodor, who proposed this extraordinary wrong way (or language organ), said: “The more global a cognitive process is, the less anybody understands it. *Very* global processes, like analogical reasoning, aren’t understood at all” (1983: 107). These are the “problems and mysteries” of generative grammar that live on and are cherished within that school or its offshoots (Itkonen 1994: 50–1).¹⁶ Analogy gives the best and only agent for universal grammar (Itkonen 1994: 50–2; cf. also 1991).

7 Summing Up, through “Psychology and Cognitive Science”

There is one work that nicely gives the good points of analogy as they have been expounded over the past two millennia: Holyoak and Thagard’s *Mental Leaps: Analogy in Creative Thought* (1995). Some references to this work have already been given. One has to note that the authors treat the period from 1980, by which time analogy had been pretty much banned in America. They also consider only literature in English, which has become standard procedure, and there is really no linguistics, that is, language material, in the text.¹⁷ My treatment followed the tradition by considering the gestalt school and Peircean semiotics (i.e., since about 1890). A surprise for many is that Holyoak and Thagard re-establish the tradition to the dot. This Cartesian twist (real truths have to be found over and over again) was expected by those who knew the tradition. They of course give their results as “their theory.” The expectation was that if the truth had been found earlier, it would be found now again, if the investigation were properly carried out. And it did come out.

Holyoak and Thagard’s book gives it all in one place (at 320 pages the reader gets more detail than here, even if very few hints at language). Analogy is the cognitive glory of humans, and of course it can be followed up in other species also, particularly monkeys and apes. The authors trace the development of this faculty in children, and then in scientists, in religion and culture, and in empathy. They also test their ideas with computer programs. All this means exactly the same as Itkonen and Haukioja’s results: analogy proves that modularity is wrong. Analogy must be used in explanation and understanding, problem-solving, decision-making, persuasion, communication, that is, in all kinds of learning or human activity. Analogies are noticed, retrieved, compiled, and constructed (cf. Kaila 1945 above). Analogy is indeed the warp and woof between similarity, structure, models, purpose, and cause (Holyoak and Thagard 1995: esp. 5–6, 22–37, 202–9, 257–61). Humans are simply analogical animals.

Language structure and language use are also predominantly analogical, and this is why analogy is the backbone of universal grammar.

NOTES

- 1 I have balanced out the frame of the diagram by actually writing in a text (a weaving metaphor), as an antidote to all kinds of crazy textualities so popular today. It also reminds us which is which, if we are left cold with the weft. But best of all, this is a direct example of perception requiring balance (closure), that is, we have a case of "esthetic" analogy.
- 2 Similarity (analogy) in myth and cultural concepts comes out nicely in the basic encyclopedias, for example, the *Britannica CD 97*. See also Itkonen (1994: 45) and Itkonen and Haukioja (1996: 165), as well as Holyoak and Thagard (1995: 59).
- 3 In the historical surveys Esper (1973) supports the Paul line, whereas Best (1973) comes to the Hermann side. The verdict is also clear: Paul's proportion $A : A' :: B : X \rightarrow A : A' :: B : B'$ is just a special case of Hermann's $A_c :: B_c \rightarrow A :: A'_c$ (in which the subscript represents some kind of conceptual similarity, and this pushes greater formal similarity).
- 4 I will take a short cut in that I refer only to the editor of this volume, not to its individual authors (for a more detailed profile, see Anttila 1992a). This is a very important theoretical volume, never referred to, and it appeared right at the time when linguistics started to get derailed.
- 5 Both isomorphism and analogy are defined as structural similarity and they are of course related (Itkonen 1994: 44).
- 6 Or, as youths in Central Ohio (information from Brian Joseph, pers. comm.) say, "on accident," an analogy squaring standard *on purpose* and *by accident*.
- 7 In this rich literature on metaphor under cognitive auspices, there is usually no mention of the Shapiros' work (e.g., Shapiro and Shapiro 1988; and earlier). This is the tradition that has produced the most exciting work on metaphor, Haley (1988). Now one must add/peruse Keller (1995).
I would further single out Bosch (1985) and Bencze (1989), as they come to a position very compatible with the one delineated above. Among other things, they emphasize the context (field) and do not draw a line between normal and figurative readings. Bencze addresses the issue of determination almost in Peircean terms and treats symmetry dynamics with reference to some of the same authors von Slagle (1974; see Anttila 1992a) was relying on when he stressed the same. Danesi's work has the added bonus and interest that he refers to Vico and Nietzsche for emphasizing the primacy of metaphor. Metaphor is the backbone of all cognition and there is no knowledge apart from it (Danesi 1987: 157, 159, 160–1, 163, 1990: 228). Context is crucial, which shows an immediate affinity to analogy. In the dispute over the literal versus figurative readings, the metaphors are basic, primary (Danesi 1987: 160, 162), and this

- makes the generative position totally wrong (for more references, see Anttila 1992a).
- 8 I myself have fallen under the same criticism in my defense of analogy, which I took as the same kind of backbone in Anttila (1989, 1977) as the cognitive linguists now use metaphor for. Curiously, this kind of work on analogy has never been referred to in the cognitive linguistics context, although analogy is now a commonplace in artificial intelligence (AI). There tends to be this distribution: analogy in artificial intelligence, metaphor in cognitive linguistics, and both in philosophy of science, from which then metaphor does also enter AI (see, e.g., Thagard 1988; Helman 1988). Ever since Aristotle, analogy has been the basic category for talking about cognition. Thus it is no wonder that linguists return to it after aberrations. This happened ultimately in generative grammar (Anttila 1977; and see Itkonen's work below). Now all kinds of terminological equivalences must be known, a great burden in the field.
 - 9 Metaphor is a prime example of analogy (Itkonen 1994: 46). Analogy and metaphor are the same and not the same (Holyoak and Thagard 1995: 220, 223, 235).
 - 10 Of course, if we want to be really scholarly we might put this into Greek: meaning is schizoantikeimenic and schizosemasic. It is now that analogy starts to sound good, and it also is Greek.
 - 11 We have here an often-noted problem in the current field. If such ignorance is real ignorance, it means serious incompetence.
- If it is done on purpose, it does not deny incompetence, but adds a damning moral flaw, not earlier tolerated in scholarship. Today both aspects are tolerated, as long as the "scholar" makes a name for himself or herself.
- 12 Andersen (1973), a deservedly influential article, is flawed in that it treats abduction and deduction only, clearly giving emphasis to the latter. Its "flavor" is against analogy, and thus it was no wonder that Savan (1980) had to put induction in there, a fact not noticed by many.
 - 13 Some modern readers might miss the point that *átopon*, from Greek α - 'un' + $\tau\omicron\pi$ - 'place,' has the same semantic elements as *utopia*, from Greek $\omicron\nu$ - 'not' + $\tau\omicron\pi$ - 'place,' as well as the beginning of *topology*.
 - 14 This indexical tension is again a facet of the larger well-known component of "strangeness" (the *átopon*) in hermeneutics, which also lurks in dissonance and coherence theories of meaning (cf., e.g., Itkonen 1983: 205–6; Anttila 1989: 405–7, 409–11).
 - 15 The generativists reverse this procedure, even taking as a norm something that never happens (Itkonen 1983: 309).
 - 16 A good state-of-the-art position on modularist thinking (or avoidance of thinking?) is Fromkin (1997); see also Haukioja (1993 with his discussion with Fromkin, pp. 398–405).
 - 17 A brief bibliography of the history of analogical treatments around language can be had through a combination of Best (1973), Esper (1973), Anttila (1977), Anttila and Brewer (1977), and Mayerthaler (1980a).

11 Analogical Change

HANS HENRICH HOCK

Since the time of the Neogrammarians, analogy has generally been accepted as a major force in linguistic change. However, opinions have varied as regards the definition of analogy and analogical change, its relation to morphological change and to sound change, and the question of whether there are natural tendencies in analogical change. This chapter attempts to present a critical overview of the major perspectives and, toward the end, to reconcile some of the contradictions in these perspectives by way of a hypothesis which views sound change and analogical (and semantic) change as points on a continuum of changes that may be considered analogical in a larger sense.¹

To facilitate the following discussion I start with a brief presentation of some of the major phenomena which have been considered analogical. (For further details see Hock 1986, with updates in Hock and Joseph 1996.)

Four-part analogy operates on the basis of a proportional model of the type (1) and generalizes a pattern of morphological relationship between given forms to other forms which previously did not exhibit this pattern, as in example (2). Certain conditions increase the success of this type of analogical change. These include the fact that the “x-”side of the equation should be a synchronically derived form (such as “plural” versus “singular”) and that the pattern being generalized should be productive.² (The term *backformation* is used in reference to the much rarer cases in which the equation is “solved” on the side of the synchronically basic form.)

(1) a : a'
b : X = b'

(2) dog : dog-s
cat : cat-s
... ..
cow X = cow-s (replacing earlier *kine*)

Leveling eliminates (morphophonemic) alternations within paradigms, as in (3). The process is most successful if the alternations do not signal important morphological distinctions. For instance, in (3) the vowel alternations in the past tense forms are eliminated, but a difference remains between the present and past tense vowels, since the present: past distinction is a relatively important one in English:

(3)	<i>Old English</i>		<i>Modern English</i>
	pres.	<i>ceosan</i>	<i>choose</i>
	past sg.	<i>ceas</i>	} <i>chose</i>
	past pl.	<i>curon</i>	
	past pple.	<i>coren</i>	<i>chosen</i>

*Morphophonemic extension*³ is a rarer alternative to leveling. An example is the British English “intrusive *r*” which is inserted between a word-final (non-diphthongal) vowel and a following word-initial vowel and which traditionally is motivated in terms of a proportion of the type (4):

(4)	the matter [əØ] was	:	the matter [ər] is
	the idea [əØ] was	:	X = the idea [ər] is

Blending telescopes the meanings or functions, as well as the phonetic forms, of two structures into a single form, as in Lewis Carroll’s *chortle* = *chuckle* and *snort*.

Contamination refers to changes in which a particular form influences the pronunciation of a semantically related form, without changing the meaning of the latter. Examples are especially common in antonyms and numerals. See, for instance, (5):

(5)	PRom.	<i>*gravis</i>	‘heavy’	:	<i>*levis</i>	‘light’	
		→	<i>*grevis</i>	‘heavy’	:	<i>*levis</i>	‘light’

Recomposition and *folk etymology* are two related processes that assign transparent compound structure to words; in the former case, this is the historically correct structure (6a), in the latter case it is not (6b):

(6)	a.	Old Engl.	<i>hūs-wīf</i>	‘house-wife’	>	Mod. Engl.	<i>hussif/hussy</i>	
							→ <i>house-wife</i>	
		b.	Old Engl.	<i>sām-blind</i>	‘half-blind’	>	Mod. Engl.	<i>samblind*</i>
							→ <i>sand-blind</i>	

Of these processes, the first three tend to apply with much greater systematicity than the remainder. However, as is well known, the Neogrammarians regarded all analogical change as irregular, in contrast to sound change which, with certain well-defined exceptions, was considered to be absolutely regular.

Note further that although all of the processes have been considered analogical in much of the literature, this does not mean that all historical linguists subscribe to that view. At least in part, differences of opinion reflect the history of the notion “analogy” before it was adopted (or adapted) in historical linguistics.

1 The History and Definition of the Term “Analogy”

As is well known, the term “analogy” goes back to Ancient Greek philosophy and grammar.⁴ Even the Ancient Greek and Roman tradition, however, varied to some degree in the definition of analogy, either as regular inflection or as proportion (see Best 1973: 16 with references); but Best may be correct in arguing that the original reference is to proportion.

The use of the term analogy to designate regular inflection (or paradigm regularity) and/or proportion continues into medieval and early modern times.⁵ In addition, however, it also tends to be used in reference to any observed regularity, including regularity in sound correspondences, as in the following passage from Schlegel (1808: 6):⁶

In this regard we permit no kinds of rules that change or transpose the letters, but demand complete identity of the word for proof of descent. True, if the intermediate links can be established historically, then it is possible to derive [It.] *giorno* from [Lat.] *dies* [‘day’]; and if instead of the Latin *f* we often find *h* in Spanish, if Latin *p* very frequently becomes *f* in the German form of the same word, and [Lat.] *c* not infrequently *h*, then this does establish an *analogy* also for other not quite so obvious cases. However, as stated, one must be able to establish the intermediate links or the general *analogy* historically; nothing may be invented on *a priori* grounds, and the agreement must be very precise and evident to permit even minute formal variations. (my translation and emphases)

Given this understanding of analogy, combined with the Romanticist notion of a perfect proto-language, it is understandable that analogical developments of the sort outlined at the beginning of this chapter generally were considered instances of “false analogy,” the transfer of a linguistic form from the original pattern – or analogy – to one that is historically incorrect and therefore a feature of late “decaying” languages.⁷ (Curiously, the term “false analogy” is much easier to find in the Neogrammarians’ attacks on earlier linguists than in the work of these linguists; but see Bhandarkar 1877–8: 14 and *passim* for genuine uses of the term.)

The Neogrammarians generally credit Scherer (1868) and Leskien (1876) with laying the foundation for a proper assessment of analogy as a perfectly normal

type of change which can take place at any stage in history, including in the proto-language; see Osthoff and Brugmann (1878). Koerner has shown recently (1983b) that a very similar view can be found in the work of Schleicher.⁸

Interestingly, the Neogrammarian definition of analogy entailed a significant change in the meaning of the term – instead of referring to synchronic regularity, it now was used to designate a historical phenomenon which was considered inherently irregular, in contrast to the “absolute regularity” of sound change.

Nevertheless, for some of the Neogrammarians analogy retained some of its traditional meaning in that its use was limited to *proportional* analogy (what is here called four-part analogy and morphophonemic extension), while other phenomena, such as leveling, are expressly excluded. See Paul (1880: 106–20, 189–216, and esp. 161 n. 1).^{9,10}

Paul’s approach was accepted by Sturtevant (1947: 97), who, however, includes cases where leveling and four-part analogy can be said to cooperate and lead to fairly sweeping results (the type Latin *honōs, honōrem* → *honor, honōrem*, for which see Hock 1986: 180).¹¹ Similarly, Saussure (1916: ch. VI) characterizes folk etymology as different from (proportional) analogy; Jeffers and Lehiste (1979: 68) restrict the term “analogy” to proportional analogy; Miranda (1974) argues for a strict distinction between proportional analogy and leveling; and Kuryłowicz’s “laws” work best for proportional analogy, while leveling is better accounted for by Mańczak (see section 2 below).

At the same time, as acknowledged by Paul (1880: 161 n. 1), many other linguists operate with a much less restrictive definition of analogy. For instance, Brugmann (1906: 16–18) includes proportional analogy, leveling, contamination, and backformation under the heading “Analogiewirkung, Neuschöpfung und Umbildung”; Wheeler’s (1887) classification of analogy embraces blending, contamination, and folk etymology, in addition to proportional analogy and leveling; and Hermann (1931) vigorously argues against limiting analogy to proportional phenomena and emphasizes, among others, the factors of contiguity within the sentence and of phonetic/semantic associations (as in folk etymology). See also Bloomfield (1914: 221–37); Buck (1933: 45–7).

In fact, most recent publications adopt such a more inclusive definition; see, for example, Anttila (1972: 88–108 ≈ 1989: 82–94); Hock (1986: ch. 9); Lehmann (1962: 177–92, 1973: 189–92, 1992: 219–34); McMahon (1994a: 70–91);¹² Trask (1996: 105–12).

Bloomfield (1933: 404–24) goes even farther by including the semantic re-interpretation of *meat* (‘food’ → ‘meat’) under the heading of analogy, even though the change has no phonetic or phonological effect. Something similar is found in Boretzky’s treatment of analogy (1977: 129–42). While on pp. 134–5 he operates with a relatively narrow definition of analogy which excludes folk etymology and blending, on pp. 138–42 he envisages a broader definition, which is not limited to phonetic results and includes even semantic extension. Anttila’s definition of analogy in this volume is even broader and certainly includes metaphorical extension.

Even if semantic changes of this type, which have no phonetic effects, are excluded, it may be legitimately asked whether we should not include changes in overt form that are purely semantically driven, such as taboo distortion (as in Mod. Engl. *doggone* or *shoot!*) and onomatopoeic (re)creation (as in Mod. Engl. *chirp* or *cheep*, which in effect have replaced *pipe* [payp], after the Great English Vowel Shift disrupted the iconic relationship between earlier *pipen* and the sound depicted by the word).

Put differently, the question is this: there seems to be a continuum, ranging from the more formally motivated proportional analogy, leveling, and morphophonemic extension, via more semantically driven blending, contamination, and folk etymology, to the even more clearly semantically motivated taboo distortion and onomatopoeic (re)creation which have some formal repercussions, to semantic shifts without such formal repercussions (as in the case of *meat*). Where, in this continuum, should we draw the dividing line, on what grounds should we draw it, and should we draw one at all?

2 Tendencies in Analogical Change

Perhaps the most widely accepted tendency of analogical change is the notion that leveling serves to establish the principle of “one meaning, one form” and to eliminate variation that does not serve a morphological purpose; see, for example, Anttila (1972: 107 = 1989: 107, with references to earlier literature); Hock (1986: 168). The tendency has been named Humboldt’s Universal by Vennemann (1969: § 2.23, 1972: 183–5).

Lass (1997: 342–52) claims that the “universal” is empirically untestable “and therefore uninformative” (p. 344). However, his assessment seems overly pessimistic, for it would *a priori* be possible to falsify the principle by showing that analogical change more commonly introduces than eliminates variation that has no morphological purpose. Significantly, this does not seem to be the case.

A more general discussion of the tendencies of analogical change originates in the disagreement between Kuryłowicz (1945–9, see also 1964b, 1968) and Mańczak (1958, 1966, 1978, 1980). The scholars disagree in their basic approach (introspective and morphology-oriented for Kuryłowicz, empirical-statistical and more phonology-oriented for Mańczak), as well as in specific claims. In the following I focus on what I consider the major issues in this disagreement; for fuller discussion see Best (1973: 61–107); Anttila (1977: 76–80); Collinge (1985: 249–53); Hock (1986: ch. 10);¹³ Winters (1995); and the references in these publications.

The most notable conflict is found between Kuryłowicz’s first law of analogy and Mańczak’s second tendency. Pointing to developments of the type (7), Kuryłowicz claims that bipartite markers, such as the plural marker *-ə* plus umlaut, tend to replace simple markers that have the same function, such as the plural marker *-ə* without umlaut. Mańczak, by contrast, states that root

alternations are more often abolished than introduced – the essence of what Vennemann has called Humboldt’s Universal:

- | | | | | | | |
|--------|-----|-------------|-------------|-----|---------------|----------------------|
| (7) a. | OHG | <i>gast</i> | : | pl. | <i>gest-i</i> | ‘guest(s)’ |
| | | <i>boum</i> | : | | <i>boum-a</i> | ‘tree(s)’ |
| | b. | NHG | <i>Gast</i> | : | <i>Gäst-e</i> | [-ə] |
| | | | <i>Baum</i> | : | <i>Baum-e</i> | [-ə] → <i>Bäum-e</i> |

Following Hock (1986: 235–6) we may resolve this conflict by noting that the two approaches address different phenomena. The change in (7) involves four-part analogy and is motivated by the fact that the alternation is serving a morphological “purpose” – of more clearly marking plural forms. On both counts the changes differ from the more common type (3) above, which involves leveling of alternations that do not serve such a purpose.¹⁴

While this perspective accounts for the fact that both types of change are possible, skeptics such as Lass may raise the question of why clear plural marking is “morphologically useful” in German, but not in English, which has tended to eliminate umlaut plurals (mainly through extension of the s-plural). There is no ready-made answer to this question, but there is no ready-made answer, either, to the question of what makes a particular type of formation productive (see n. 2) – even though the concept of productivity is clearly a valid one, and plays a major role in analogical change.

Kuryłowicz’s second law of analogy makes a claim about the general direction of analogical change, namely that it proceeds from basic form to derived form. Moreover, it states that the relationship between these forms “is a consequence of their spheres of usage.” As shown in detail by Hock (1986: 213–22), the “sphere of usage” provision is especially significant. First, it incorporates the observation that productive patterns, which presumably are used more freely, are more successfully extended in four-part analogy. Second, it invites us to examine more closely the question of what is basic within particular formal categories and thus provides a principled explanation for some of Mańczak’s rather random observations, such as the claim that geographic nouns tend to preserve locational cases better than other cases (Hock 1986: 232–4). A further corollary of the sphere of usage provision is the often-claimed tendency for third persons to be more basic in analogical change than other forms of the verb (Hock 1986: 220–2) – a tendency which has been called Watkins’s law (Arlotto 1972: 156; Joseph 1980a).¹⁵

In spite of its significance, Kuryłowicz’s second law clearly is not without problems. Most obviously, it is contradicted by backformation, which violates the “basicness” provision of the law. At the same time, it is well known that backformation is less systematic and successful than four-part analogy, and this behavior may be considered to confirm the law at least as a tendency. More serious is the fact that the law holds as a valid tendency only for proportional analogy and fails to make correct predictions for leveling¹⁶ and most other analogical developments (Hock 1986: 213–14).

Kuryłowicz's fourth law sums up the conventional insight of historical linguists that, when analogical change results in doublets, such as innovated *brothers* versus archaic *brethren*, the newer form tends to take on the productive function and the older form survives in specialized or otherwise marked usages.

The law's validity has been questioned by Lehmann (1973: 200, 1992: 232) and Kiparsky (1974a). Lehmann notes that in German, the innovated genitive form of the definite article, *dessen*, has marked functions compared to the older form, *des*, in violation of the law. Kiparsky points to examples such as (8), where innovated forms are found in more marked, rather than less marked, structures:

(8)	<i>Primary function</i>	<i>Special function</i>
a.	<i>teeth</i>	<i>Sabertooths</i> (tigers)
	<i>leaves</i>	<i>silverleafs</i> 'white poplars'
	<i>geese</i>	<i>silly geeses</i> 'stupid people'
b.	<i>wolves</i>	<i>wolfs</i> 'aggressive men'

While isolated examples, such as Lehmann's, may merely serve to remind us that Kuryłowicz's "laws" are just tendencies,¹⁷ Kiparsky's counterexamples are quite numerous and thus cannot be ignored.

Hock (1986: 226–7) proposes that examples of this type are not real counterexamples, since the regularized forms on the right are not directly derived from the simple singular forms (*tooth*, *leaf*, *goose*, *wolf*), but from the semantically and/or formally derived expressions *Sabertooth* (tiger), *silverleaf* (poplar), *silly goose* 'stupid person,' *wolf* 'aggressive man,' and are thus regularizations within derived forms. This account is accepted by Winters (1995: 120) and Anderson (1988: 359–60).

McMahon considers the explanation "at best impossible to prove" (1994a: 78). However, this assessment is dubious, for it can easily be shown that regularization affects only the derived structures. For instance, *Sabertooths* have *saber teeth*, *silver leafs* have *silver leaves*, *geese* that are *silly* will be called *silly geese*; and for the last item, Winters notes formal variation, with *wolves* preferred by speakers "who associate the meaning of 'lecherous men' with the animal," and *wolfs* by "those who do not make this connection" (1995: 210).

Early generative approaches tended to view analogical change as grammar change and, moreover, as grammar simplification; see above all Kiparsky (1965) and King (1969). The view of analogical change as grammar simplification was soon seen to be problematic in the case of leveling. Take, for instance, the *s/r* alternation in example (3) above. Before any leveling had taken place, this alternation was regular in strong verbs with original root-final *s*, while roots with original final *r* had invariable *r*. Now, it could be argued that this situation is complex and therefore invites change. But the early stages of leveling, when the change affected only a few forms, introduced an even more complex

situation – some roots had invariable *s* (due to leveling), others invariable *r* (from older *r*), while a third set retained the *s/r* alternation. Only after centuries of leveling did English reach the modern stage, where the *s/r* alternation in verbal paradigms is limited to the idiosyncratic *was : were* and therefore practically defunct.

Over time, Kiparsky came to accept that not all analogical change can be accounted for as grammar change (e.g., Kiparsky 1978). Moreover, his view changed drastically as to what motivates those analogical changes which can legitimately be considered grammar changes (see the progression from Kiparsky 1968 to 1971 and 1973b, 1973c). The claim which has had the greatest staying power is that changes in the grammatical rule system are motivated by a preference for *transparent* rule interactions over *opaque* ones.

Consider, for instance, the relationship between German final devoicing (FD) and final *ə*-loss in (9). Historically, final devoicing preceded *ə*-loss (9a). Once *ə*-loss took place (9b), it made the synchronic rule of final devoicing opaque, by providing counterexamples to the rule's prediction that all final obstruents are voiceless. The opacity was removed, and transparency restored, by "reordering" *ə*-loss before final devoicing, so that final devoicing could affect all final obstruents (9c) (--- = does not apply):¹⁸

(9) a.	OHG	nom.sg.	<i>tag</i>	dat.sg.	<i>tage</i>
	FD		<i>tak</i>		---
	pre-NHG		<i>tāk</i>		<i>tāgə</i>
	<i>ə</i> -loss		---		<i>tāg</i>
b.	Expected NHG		<i>tāk</i>		<i>tāg</i>
c.	Synchronic NHG		/tāg/		/tāgə/
	<i>ə</i> -loss		---		tāg
	FD		<i>tāk</i>		<i>tāk</i>

As shown in Hock (1986: ch. 11), the rule-based approach of traditional generative phonology makes it possible to explain not only instances of rule reordering, but also the broader and more significant issue that changes of this type, as well as morphophonemic extensions (as in (4) above) differ from ordinary analogical change by exhibiting the same regularity as sound change. The point is that these extensions are not motivated simply by the morphological and semantic relationships between individual words, but by general features of phonological structure.

While generative phonology now has turned away from the earlier derivational, rule-based approach, and toward "declarative," constraint-based approaches such as Optimality Theory, the earlier framework's insights on the motivations for sweeping analogical change remain relevant. Here, too, however, a word of caution is in order. As observed by Hock (1986: 271–4), considerations of morphological transparency may be in conflict with phonological transparency and may, in certain cases, override the latter.

3 Analogical and Morphological Change

Traditional historical linguistics has tended to identify morphological change as analogical change, with or without the added comment that the proportions which give rise to analogical change can also motivate the creation of new structures. Implicit or explicit in such discussions is the understanding that sound change, too, may bring about changes in morphology, especially through loss or reduction of inflectional affixes.

Discussions of borrowing also often include some remarks that borrowings can introduce new morphology which may or may not be extended to native words. The potential effect of borrowing on morphology can be illustrated by a slightly extended form of the classical English sesquipedalianism, *disestablishmentarianistically*, containing (at least) eight affixes, of which only the final one, *-ly*, is of native English origin.

Two recent developments in linguistics have brought about a change in perspective, by showing that morphological change can result from several factors other than analogy, reinterpretations that give rise to analogy, sound change, and borrowing. One of these is the study of “grammaticalization,”¹⁹ the other is “natural morphology.”²⁰ Since the latter is treated in full in Dressler’s contribution to this volume I will focus here on grammaticalization, except to note that natural morphology has contributed especially by directing our attention to the nature of morphological systems and the fact that this nature may itself influence the direction of change.

As advocates of the grammaticalization framework point out, the notion “grammaticalization” has antecedents going back to Meillet (1912) and even to the earliest stages of comparative Indo-European linguistics; for example, the work of Bopp (1816). (See, e.g., Hopper and Traugott 1993; Traugott and Heine 1991a, 1991b; for the early antecedents, see Heine et al. 1991.) In spite of these hoary antecedents, however, the framework has had a significant impact only in very recent historical linguistics publications; for example, McMahon (1994a: 69–106 with 160–73); Trask (1996: 102–29 with 143–7); Hock and Joseph (1996: 153–88, esp. 176–84 with further discussion on 292–317).

A major claim of grammaticalization studies is that semantic bleaching, cliticization, phonological reduction of clitics and of other semantically downgraded elements, and the reinterpretation of such elements as affixes contribute to a flow from full words toward grammatical affixes. Compare, for instance, the examples in (10) and (11):

- | | | | | |
|---------|------------|-------------------|------------------------------|--------------------------------|
| (10) a. | OE | <i>cild-hād</i> | ‘child-condition’ (compound) | |
| | Mod. Engl. | <i>child-hood</i> | (root + affix) | |
| | b. | OE | <i>fr̥eo-dōm</i> | ‘realm of the free’ (compound) |
| | | Mod. Engl. | <i>free-dom</i> | (root + affix) |

- (11) “Clitic cycle,” from full word to clitic to affix:
- Late Imperial Latin *vidēre habēō* ‘I have to see’
 - > ‘I will see’ (with semantic reinterpretation/fading)
 - > Old Span. *veer=he* ‘I will see’; *veer=lo=he* ‘I will see it’ (with cliticization of ‘have’ and the possibility of “stacking” clitics between the verbal infinitive and the clitic *he*; = indicates clitic boundary)
 - > Mod. Span. *ver-é* ‘I will see’ (with change of (*h*)*e* into an affix, which precludes insertion of a clitic pronoun: *ver=lo=e***; – indicates morpheme boundary)

Grammaticalization studies tend to claim that this development is unidirectional, that is, that there are no changes from, say, affix to clitic, or from clitic to full word. While such contrary changes are in fact rare, some examples have been cited, inter alia by Campbell (1991); Joseph and Janda (1988); Nevis (1986). Hopper and Traugott (1993: 126–8) attempt to account for these as the result of a different process, which they call “lexicalization.” If this account is accepted, it might indeed be possible to claim that grammaticalization is unidirectional; but it would also be impossible to falsify that claim (see now Janda 2001).

4 Analogy and Sound Change

As is well known, the Neogrammarians postulated a fundamental difference between regular sound change and sporadic, irregular analogical change. And they tended to consider analogy to be a response phenomenon which undoes the destructive effect of sound change on morphology, especially on inflectional endings. This relationship has been commented on repeatedly, including by Bréal (1878) and Bally (1913: 44). Anttila (1972: 94–5) appears to have been the first to refer to it as Sturtevant’s Paradox, because of its remarkably stark formulation by Sturtevant (1947: 109):²¹

Phonetic laws are regular but produce irregularities.
Analogic creation is irregular but produces regularity.

In fact, however, the relationship is limited to leveling and sound change; other analogical processes have the relation only incidentally, if at all; see Hock (1986: 171). For instance, analogical formations such as *campuses* as the plural of *campus* (instead of the Latin plural *campi*) are not responses to sound change, but serve to regularize the inflection of a borrowed word.

4.1 Grammatical conditioning?

At least since Schuchardt (1885) a variety of scholars have disagreed with the strict Neogrammarian distinction between sound change and analogy.

Disagreement tends to focus on two major issues – “grammatical conditioning” of sound change and “sound change as analogy.”²²

According to the grammatical conditioning hypothesis, analogy may block or condition sound change as it is taking place, instead of having to wait for the completion of sound change before repairing its effects. For an early comprehensive defense of this position see Hermann (1931). The hypothesis was revived in 1968 by Postal and was especially current in the 1970s; see, for instance, Anttila (1972: 78–81, 85–6); Cerrón-Palomino (1974, 1977); Langdon (1975); Malkiel (1968); Melchert (1975); Sihler (1977); and more recently Kiparsky (1988: 373). The most recent reiteration of the claim that I am aware of is found in Campbell (1996: 78–80).²³

While the grammatical conditioning hypothesis thus has numerous supporters, many (perhaps most) of the examples cited in its favor have been shown to be amenable to an “orthodox” Neogrammarian analysis of sound change followed by analogical change; see, for example, Kiparsky (1973*c*, *contra* Postal) and Hock (1976, *contra* Anttila), as well as the discussion in Bloomfield (1933: 362–4, *contra* early opponents of the Neogrammarians).

Especially important are cases where it can be shown that a Neogrammarian approach provides a better and more comprehensive explanation than a grammatical conditioning account. Consider, for instance, one of the cases for grammatical conditioning brought forth by Anttila (1972: 80): in western Finnish dialects apocope is limited to case endings, but does not occur in stem-final position. Hence we find *taka-na* > *takan* ‘behind’ versus *pakana* ‘pagan.’ As it turns out, Standard Finnish exhibits the opposite tendency – stem-final vowels tend to be lost, while the vowels of endings generally remain. Hock (1976: 215 with references) suggests that both situations can be accounted for by assuming an early regular change of apocope which affected words of three or more syllables and resulted in alternations between forms with and without final vowel – both in stems and in endings – depending on the number of preceding syllables. The dialectal differences, then, result from different leveling resolutions of these alternations. Hock concludes that “only an analogical explanation will account for the no doubt related western and Standard Finnish phenomena in a coherent fashion. A grammatical-conditioning analysis would have to consider these facts as unrelated.”

Nevertheless, even Hock (1976: 217) admits that there may be some genuine cases of grammatical conditioning, especially the one discussed by Cerrón-Palomino (1974). See also section 4.3 below.

Under the circumstances, there is no *a priori* way of deciding whether a given situation should be accounted for by grammatical conditioning or by a Neogrammarian analysis. True, the number of clear cases of grammatical conditioning is quite limited. However, rarity is not identical with impossibility.

More important is the fact that the Neogrammarian approach is heuristically more useful, in that it forces us to examine the data more carefully than an approach which can invoke grammatical conditioning. Thus, in the Finnish case, there is no motivation to look beyond the western Finnish dialects if

grammatical conditioning is considered an appropriate explanation; by contrast, a Neogrammarian approach which rejects grammatical conditioning invites examination of additional data (such as Standard Finnish), so as to provide support for its account. One might therefore argue that the null hypothesis should be the Neogrammarian account, and that grammatical conditioning should be invoked only when absolutely necessary. Still, heuristical usefulness is not identical with historical accuracy.

4.2 *Sound change as analogy*

The second anti-Neogrammarian position claims that there is no difference between sound change and analogy and that sound change is simply a sub-type of analogical change. Schuchardt (1885) merely asserted this claim, without empirical foundation, and without explicit explanation as to why some types of analogical change come out as “regular sound change” while others do not.

A first approximation of an answer was provided by Sturtevant (1917: 81–2, 84), who claimed that “sound change” starts in a few isolated words, in the speech of one or two individuals, and spreads to other words and speakers by imitation. In this spread:

each person who substitutes the new sound in his own pronunciation tends to carry it into new words . . . Such a spread of a sound change from word to word closely resembles analogical change; the chief difference is that in analogical change the association groups are based upon meaning, while in this case the groups are based upon [phonetic] form.

Empirical evidence for this view of sound change was provided by Gauchat’s (1905) study of a Swiss French mountain dialect and a follow-up study by Hermann (1929).

With Labov’s work (especially 1965a, 1965b) and his explicit references to the earlier work of Gauchat and Hermann, this view began to enter mainstream historical linguistics. Even then, however, Labov’s tendency to capture the rule-governed nature of linguistic change through the concept of variable rules (e.g., 1972b) made it possible to maintain the position that sound change is fundamentally different from analogical change.

More direct continuations of the Schuchardtian tradition are found in lexical diffusionist literature, in Wang (1969) and recently again in Wang and Lien (1993), both of which explicitly refer to Sturtevant’s analogical account of sound change.²⁴ However, because it tries to subsume all changes in sound under the single concept of lexical diffusion – whether traditional sound change, analogy, or even dialect mixture – the lexical diffusionist framework has tended to remain on the margins of mainstream historical linguistics. (For critical evaluations see, e.g., Harms 1990: 313; Hashimoto 1981; Hock 1986: 651–2.)

Significantly for present purposes, both the approach of Labov and his followers and the lexical diffusionist approach have grown out of a framework that denies the Neogrammarian distinction between sound change and analogy and considers sound change a special type of analogy.

4.3 The “Neogrammarian controversy”

Moreover, the work of Labov and Wang and their followers shows that even sound changes outside the Neogrammarian category of sporadic sound change may not reach full regularity. While the Labovian school tends to focus on changes that do so, or at least come close to regularity, the Wangian school emphatically asserts that sound change often is irregular.

There are, in fact, numerous examples of incomplete, irregular sound changes (see example (12) below) and even of changes that are reversed in mid-stream and hence become irregular (see Hill 1940; Timmers 1977):

(12) *English ū-shortening:*

- a. Change completed: *foot, book, cook*, all with [ʊ]
- b. Change in progress: *roof, root, hoof*, with [ū] ~ [ʊ]
- c. Unchanged: *food, shoot, loop*, with [ū]

Labov (1981, 1994: 419–543) tries to resolve this “Neogrammarian controversy” with the proposal that irregular change, that is, lexical diffusion, takes place when change affects more “abstract” or “complex” features, as in “lengthening and shortening in vowels, and changes of articulation in consonants,” while change tends to be “Neogrammarian” or regular elsewhere. If correct, Labov’s account would provide a principled explanation of the difference between regular and irregular sound change. Unfortunately, however, it would incorrectly predict that most changes affecting vowel length (such as the elimination of Latin length distinctions in Romance) or most changes in place of articulation (such as [r] > [ʀ] in various European languages and dialects) would be irregular; see, for example, Janson (1983).

Kiparsky proposes an alternative account (1988: 398–404) within the framework of lexical phonology. In his view examples of lexical diffusion “invariably involve *neutralization* processes” which eliminate lexical contrasts (p. 399, original emphasis). Unfortunately, while many cases of lexical diffusionist sound change do indeed eliminate lexical contrasts, some do not (see, e.g., Krishnamurti 1978). Moreover, Kiparsky’s implicit prediction that all changes involving lexical neutralization are irregular is in conflict with the fact that many such changes are regular (such as the merger of palatal, retroflex, and dental sibilants in most of Middle Indo-Aryan or the Romance loss of length distinction in Latin *ā* and *ǎ*).

Hock (1986: 652–3) suggests that what may be more significant is that where change can be observed in progress, “Neogrammarian” change is characterized

by strong social marking, while irregular, “lexical diffusionist” change has fairly weak social marking; see Labov (1981: 296). Hock proposes that it is this difference in social marking which is responsible for the difference in behavior.

This proposal, if correct, would be eminently compatible with Labov’s basic theory of social motivation of change. Unfortunately, the result would be that we cannot predict on purely linguistic grounds which types of sound changes are likely to be regular or irregular (except for changes such as dissimilation and metathesis).

As it turns out, there is a fair amount of additional evidence that casts doubts on the strict Neogrammarian distinction between regular sound change and sporadic, irregular analogy.²⁵

Some of this evidence was already known to the Neogrammarians, namely the fact that certain types of change (including dissimilation and metathesis) are normally irregular; and the Neogrammarians made a point of excluding them from their regularity hypothesis. However, this attempt to rule out dissimilation and metathesis runs into the difficulty that some instances of these changes are completely regular; see Hoenigswald (1964). Hock (1985, 1986: 111–16, 1987 with references) suggests that these changes tend to be regular if they operate in general, phonologically defined domains. Even so, changes of this type straddle the fence between regular and sporadic change.

In addition, we now know that there is regular, rule-governed analogy, as in (4) and (9) above. While clearly analogical in nature, developments of this sort exhibit all the regularity of sound change²⁶ and thus challenge Neogrammarian doctrine from the “other side of the fence”; see Hock (1986: chs 11, 20).

Finally, there is a small but growing body of sound changes which, unlike similar changes, can only be explained analogically. For instance, Moulton (1960, 1961a) shows that the low front vowel [œ] in Swiss German dialects results from four-part analogical change, while at the same time being phonologically motivated as making the vowel system more symmetrical. Trager (1940) points out that four-part analogy introduces a phonological contrast between [æ̃] and [æ̃̃] in Eastern Seaboard dialects of American English. Similarly, Sanskrit acquires a contrast [ṛ̃] : [ṛ̃̃] by four-part analogy (Hock 1986: 208–9). While in these changes, the analogical developments take place under specific morphological conditions, some analogically motivated sound changes seem to be conditioned by purely phonological considerations. For instance, Hock (1986: 206–7, 1991) argues that initial strengthening (as in Spanish *yo* > *jo* “I”) results from the analogical extension of the phonological pattern “initial strong” : “medial weak” that results from earlier obstruent weakening in medial position.

4.4 Sound change and analogy: a different perspective

The evidence and arguments summarized in sections 4.2–4.3 suggest that, contrary to Neogrammarian doctrine, there is no clear distinction between sound change and analogy and that, therefore, we must take seriously the

Schuchardtian approach, which views sound change as a special kind of analogical change. Moreover, the fact that morphologically based analogy is at work in the Swiss German, Eastern Seaboard, and Sanskrit sound changes referred to in the preceding paragraph may suggest reconsideration of the skeptical assessment of grammatical conditioning in section 4.1.

At the same time, Labov's work has shown that most of the developments traditionally viewed as sound changes ultimately are regular in the Neogrammarian sense, or at least overwhelmingly regular. Moreover, even if the cases in the final paragraph of section 4.3 are included, grammatical conditioning of sound change is considerably rarer than the classical Neogrammarian scenario of sound change followed by analogical change. It is therefore still useful to distinguish between sound change – usually overwhelmingly regular and phonetically/phonologically conditioned – and analogy – usually irregular and morphologically/semantically conditioned.

Put differently, neither the orthodox Neogrammarian approach nor the Schuchardtian approach manages to capture all aspects of the similarities, differences, and overlaps between sound change and analogy.

Let me conclude this section by proposing a hypothesis that at least begins to resolve these difficulties. Before presenting the hypothesis, however, it is necessary to add the disclaimer that the hypothesis cannot account for some details, such as why some sound changes, especially dissimilation and metathesis, are typically irregular, or why some sound changes behave in a "Neogrammarian" way while others are "lexical diffusionist" in nature. (As suggested in section 4.3, the motivation for the latter difference may be social or sociolinguistic, rather than purely linguistic.) Similarly, the hypothesis cannot predict what makes particular morphological patterns productive.

According to the present hypothesis, sound change (as traditionally defined), morphophonemic extension and rule reordering or extension, the entire range of analogical changes, as well as at least some aspects of semantic change (mainly metaphorical changes) constitute points in a continuum of changes which may be considered analogical in the larger sense, in that they extend linguistic patterns.

The differences in behavior between these changes, in terms of (potential) regularity or systematicity, are a consequence of the differences in *domain* in which the changes can apply. The broader or more general the domain of applicability, the greater the regularity or systematicity.

Thus, Neogrammarian sound change is most likely to be regular because its applicability is not constrained by non-phonetic/non-phonological information (ignoring social or sociolinguistic factors). On a somewhat similar note, dissimilation and metathesis may be regular if part of the condition for their application is a general phonetic or phonological domain.

Analogical changes which minimally involve non-phonetic/non-phonological information, such as Brit. Engl. *r*-insertion (a prosodic phenomenon) or German "reordering" of final devoicing (which only requires knowledge of word boundaries), likewise tend to be regular.

Four-part analogy and leveling have a chance to apply to large classes of candidates (inflectional classes and paradigms that embrace larger sets of lexical items). They are therefore relatively systematic, but not usually as regular as sound change.²⁷

Other analogical changes tend to be applicable only to individual words (recomposition and folk etymology), pairs of words (blending and contamination), or small sets of words (possibly contamination in sets of neighboring numerals). As a consequence, they are quite sporadic.

Finally, while semantic fields or networks may, in limited cases, produce relatively systematic changes,²⁸ it is in the area of semantics that the slogan “each word has its own history” is most appropriate. Most semantic change therefore is highly sporadic at any given time (although there may be recurrent tendencies, such as pejorations due to gender bias).

Note that this hierarchy, by and large, correlates with a hierarchy of semantic and morphological “loading.” Sound change, morphophonemic extension, and rule extension have no semantic or morphological loading; four-part analogy and leveling are sensitive more to morphological than to semantic information; the sporadic types of analogy generally are highly sensitive to semantics (folk etymology, blending, contamination); and semantic change, of course, is semantic change.

This hypothesis also makes it possible to explain why it is difficult to find good examples of grammatical conditioning of what otherwise would qualify as Neogrammarian sound change and why a Neogrammarian scenario of sound change followed by analogical change is generally more appropriate. By its very nature, grammatical conditioning limits the domain of possible application and increases morphological loading. Grammatically conditioned sound change, therefore, would be expected to lack the regularity of Neogrammarian sound change and to exhibit behavior more similar to four-part analogy and leveling.

5 Conclusions

As I hope to have demonstrated in this chapter, the term “analogy” can be and has been used in a variety of meanings. Some of these definitions clearly conflict, but there is also a certain commonality. This lies in the fact that at least since the time of the Neogrammarians, analogical change in effect means extension. Differences and disagreements concern the domain and motivation of the extension. While some scholars limit the term “analogy” to changes with proportional motivation, a more common perspective views all the changes given at the beginning of this chapter as analogical. Significantly, however, all along there have been proposals to define analogical change even more comprehensively, so as to include sound change and (some aspects of) semantic change.

Each of these different views has its own merits, including the one mentioned last. But it is good to keep in mind that for all practical purposes the Neogrammarian distinction between sound change and analogical (and semantic) change still has much to recommend it, even if it may require some modification. Sound change typically is regular, and morphologically or semantically motivated analogy typically is irregular; but phonologically motivated analogy (such as morphophonemic and rule extension) tends to be as regular as sound change, and changes such as dissimilation and metathesis require a general phonological motivation to become regular. Moreover, the Neogrammarian scenario of sound change followed by analogy tends to be considerably more common than grammatical conditioning of sound change – in addition to being heuristically more fruitful.

Finally, while the discussion in section 4.4 may suggest that analogical change in the largest, most inclusive sense is virtually identical to linguistic change, it needs to be borne in mind that, even if we limit ourselves to internal (rather than contact-induced) change, reinterpretation plays an equally significant role, especially if we include under that concept the sociolinguistic starting-point for change – the reinterpretation of some variation as socially significant and therefore worthy of extension.

NOTES

- 1 This hypothesis to some extent converges with that of Anttila, this volume. However, it is grounded in a very different perspective of historical and general linguistics.
- 2 The question of what makes a given pattern productive is a difficult one. For attempts to deal with this issue see Dressler, this volume; but note also the skepticism in Hock (1986: 173). See L. A. Janda (1996) for an interesting discussion of how relatively marginal formations can become productive in analogical change.
- 3 Referred to as “morphophonemic proportional analogy” and “rule extension” in Hock (1986).
- 4 It is customary to claim that there was a controversy in ancient times over whether language is dominated by analogy or anomaly; see the extensive literature in Best (1973: 13–16). Best eventually accepts the view that there was some such controversy; but the “controversy” is documented only in Varro’s grammar, a rather late text. Under the circumstances, I tend to accept Matthews’s recent argument (1994) that the controversy may have been an invention of Varro’s, or at least blown out of proportion by Varro.
- 5 With some authors it continues even into the modern period; see for instance Öhmann (1960, cited in Best).
- 6 The passage is of additional interest since it anticipates Rask’s and Grimm’s celebrated accounts of 1818 and 1819 of what has come to be known as Grimm’s law.

- 7 Because of his understanding of analogy as synchronic regularity, Öhmann (1960: 12) continues (or resurrects) the term “false analogy.” Bloomfield (1914: 224), too, claims that “analogy” is merely short for “false analogy,” but he does not provide any further discussion. Kiparsky (1978: 88) uses the term in a very different sense, as a label for analogical developments that fail to lead to grammar simplification – a response to Thomason’s critique (1976) of the early generative view of analogy as grammar simplification.
- 8 Compare the following passage; but also note the continuation which, for better exposition, is placed into a separate paragraph: “Even in the earlier linguistic periods, at a time that the sounds are still more stable, a force begins to manifest itself and to act in an inimical manner on the great variety of forms and to restrict them increasingly to what is most essential. This is the just mentioned assimilation (*Anähnlichung*) of forms, especially of the ones less frequently used in the language, but which in their unusual character are quite justified, to others, especially those used frequently and thus impressing themselves strongly into one’s linguistic consciousness, that is *analogy*” (original emphasis).
- “The tendency toward a comfortable uniformity, after treating as many words as possible in the same manner, and the increasingly decaying understanding of the meaning and the origin of the unusual, entails that later languages possess fewer grammatical forms than more original ones, that the structure of language increasingly is simplified over time” (Schleicher 1860: 60; my translation).
- 9 But note p. 204, where Paul entertains the idea that leveling originates in “*Neuschöpfung nach Analogie*.”
- 10 In fact, the similarities with the earlier understanding of analogy go farther. Witness statements such as the following, which show that, in spite of his view that only historical linguistics is truly scientific, Paul appreciated the role of analogy = regularity in synchronic linguistics. Moreover, as noted in Hock (1986: 250), the tenor of Paul’s remarks is remarkably similar to that of generative linguistics, whether of the indigenous tradition of India or of the modern Western type (see also Koerner 1972, 1983a: x): “It was a fundamental mistake of earlier linguistics that everything spoken, as long as it does not differ from existing usage, was considered something reproduced merely from memory, and the consequence of this has been that people have not had any clear idea of the role of proportional groups in linguistic change . . . The words and word groups which we use in speech are only partly memorized reproductions of something heard earlier. A combinatory activity based on the existence of proportional groups constitutes an about equal part in this enterprise . . . This process we call analogical formation. It is an indubitable fact that a large number of word forms and syntactic combinations, which were never introduced into the mind from the outside, not only can be created by means of the proportional groups, but are created [in this way] again and again, with great confidence” (1880: 109–10; my translation).

- 11 In fact, Sturtevant seems to treat all instances of leveling as due to proportional analogy. Interestingly, his earlier work of 1917 offers a much broader definition of analogy (pp. 38–44), which includes blending, contamination, and folk etymology, beside proportional analogy.
- 12 But on pp. 183–4, folk etymology, contamination, and ellipsis are also classified as semantic changes.
- 13 But Hock's interpretation of Kuryłowicz's sixth law as addressing interdialectal hypercorrection is incorrect. Rather, Kuryłowicz here anticipates the tenor of Labov's hypothesis that change ultimately comes about for social or sociolinguistic reasons.
- 14 Hock further tries to resolve the issue in terms of the "polarity" of language (a concept going back to Leopold 1930), with one pole being meaning, the other, phonological form (1986: 234–6).
- 15 Bybee presents arguments that the first person singular comes next in basicness (1985: 57). See also Tiersma (1982).
- 16 Except for the fact that relatively basic forms are more likely to resist leveling (Hock 1986: 215).
- 17 It is probably a mistake to consider German *dessen* in isolation. The form is supported by the genitive of the interrogative/relative pronoun, *wessen*, which has replaced older *wes* (except in archaic contexts) and to which *dessen* corresponds not only morphologically but also syntactically (in sentences of the type *Wessen Kinder gut erzogen sind, dessen Familie gedeiht* 'whose children are well educated, his family thrives').
- 18 Hock (1986: 269) argues that the change actually was one of rule "reaffirmation," since there are German dialects which have variation between presence and absence of final devoicing in forms with final *a*-loss, but not elsewhere (nom.sg. *tāk* versus dat.sg. *tāg/tāk* < *tāgə*). To the reference cited by Hock (Friedrich 1901), add Jongen (1986: 333).
- 19 For further discussion of grammaticalization, see Bybee, Heine, Traugott, Mithun, Joseph, and Fortson, this volume.
- 20 Note also Andersen (1980), who in fact suggests abandoning the term "analogy" in favor of "morphological change" and "the semiotic conceptual framework that appears to be called for in the investigation of language" (p. 46).
- 21 Lass (1997: 342) erroneously attributes the statement to Sturtevant (1917).
- 22 For further discussion, see Hale, this volume.
- 23 See also Durie's recent claim (1996) that (Labovian-style) variable rules may be in part morphologically conditioned and that there is thus no need for the Neogrammarian analysis in terms of sound change followed by analogy.
- 24 In between, lexical diffusionists have tended to ignore Sturtevant's analogical account and to focus instead on "minor rules"; see, for example, Wang and Cheng (1970, 1971); Chen and Wang (1975). Note that Vennemann (1972a) uses Schuchardt as springboard for a very different theory of linguistic change.
- 25 Some of the following arguments are convergent with those in Kiparsky (1988); but the perspective is quite different.
- 26 In the case of British English *r*-insertion, there are two areas of apparent irregularity. First, *r*-insertion takes place only within

the same prosodic phrase, and prosodic phrasing can vary considerably, so much so that prosodic phrases may extend even across clause boundaries – and so may *r*-insertion; see Vogel (1986). The second type of irregularity is connected with the fact that *r*-insertion apparently is being extended to word-internal position (as in [sɔ:-r-lɪ] beside [sɔ:lɪ] ‘sawing’ – with the variability predicted by Labov’s theory of

sound change. If it runs its full course, the change can be expected to be regular in the outcome.

- 27 Except perhaps when they “cooperate,” as in Lat. *honōs*; see Hock (1986: 179–80).
- 28 For some cases see De Camp (1963); Hock (1986: 306–7); Hock and Joseph (1996: 244–8). Note, however, that though systematic, these changes are by their nature restricted to small, semantically highly structured subsets of the lexicon.

12 Naturalness and Morphological Change

WOLFGANG U. DRESSLER

During the last decades, “natural” has often been used by linguists in an inductive or even anecdotal way as a synonym of “intuitively plausible” or of “cross-linguistically frequent,” in reference to both synchrony and diachronic change. In more theoretical views, it often overlaps with cognitively simple (cf. Anttila, this volume), elementary and therefore universally preferred, and with Praguian (especially Jakobson’s) notions of markedness (where unmarked loosely corresponds to natural).

Naturalness is a relative, gradient concept: a phenomenon *X* is more or less natural than *Y*. For example, within English plural formation, the modern plural *cow-s* is a more natural plural of *cow* than its precedent correspondents *cyne/kin(e)*. Change from a less natural to a more natural morphological phenomenon may then be called “natural/preferred/unmarked morphological change.” Thus, naturalness studies in diachronic change usually do not deal with absolute constraints on change but minimally with tendencies or maximally with “soft constraints” or defaults. Preferences are of a functional nature (cf. Heine and Mithun, this volume) and ultimately founded in extralinguistic bases.

Tendencies of morphological change have been investigated by many with recourse to some notion of naturalness, often with a shady transition from notions of naturalness to those of simplicity, that is, to views that natural morphological change results in simplification. But only few have done that in any systematic way, notably Bailey (1982) in his “Developmental Linguistics,” Plank (1981), and Keller (1990). Most systematic work, however, has been done within the framework of “Natural Morphology” (NM) or in reference to it. A second reason for using the NM framework in this chapter is the important role that diachrony has always played in this approach.

This chapter will center on grammar-initiated, natural change, first according to universal, system-independent morphological naturalness/markedness (section 2.1), in regard to the parameters of constructional iconicity, morpho-semantic, and morphotactic transparency (including preferences for continuity

and word bases), and binarity, whereas the parameters of (bi)uniqueness, indexicality, optimum shape are dealt with in sections 2.2 and 3. Conflicts between universal parameters (section 2.2) either within morphology or with other components explain unnatural changes. After type-adequacy as a filter on change (section 3), language-specific, system-dependent naturalness (system-adequacy; section 4.1) is dealt with, followed by interaction between the three subtheories of universal versus typological versus system-dependent naturalness (section 4.2). Finally, in section 5, work on change initiated by grammar-external factors is briefly mentioned, viz. on contact-induced change, language decay, creolization, and language planning in terminology.

1 The Framework of Natural Morphology (NM)

The theory of NM¹ originated with the integration of concepts of Praguian markedness and phonological naturalness (cf. Stampe 1969) into the study of morphology and the conception of naturalness conflicts by Mayerthaler (1977) and Dressler (1977). In the same year, they, along with Wurzel and Panagl, formulated, at the 1977 LSA Summer Institute at Salzburg, a common platform later extended into Dressler et al. (1987), where morphological change occupies a prominent place. More recently, naturalness has become a cover term for a set of more specific terms to be defined in specific subtheories and to be derived from more general semiotic, cognitive, and/or psychological concepts.

These subtheories proposed since 1977 are those of universal markedness or system-independent morphological naturalness (cf. Mayerthaler 1981: 3), and of type-adequacy (cf. Dressler 1985a, 1988a: section 4), preceded by a theory of system-dependent naturalness or system-adequacy (cf. Wurzel 1984: section 5). Subtheories for interfaces with other areas of morphological naturalness were established for morphonology (cf. Dressler 1985b) and morphopragmatics (cf. Dressler and Merlini Barbaresi 1994), and Mayerthaler is establishing one for morphosyntax, within his theory of Natural Syntax (cf. Mayerthaler et al. 1994).

The focus of diachronic investigations has been on those types of morphological change where the above subtheories can explain most, that is, where no external theories appear to be crucially involved (but see sections 5 and 6). This appears to be the case when change is supposed to be mainly triggered by forces which lie within grammar or become manifest in first language acquisition. Such change has been called "grammar-initiated change" (the title of Wurzel 1994b). This term is justified in view of the (admittedly simplified) dichotomy between origin and spread of change. Whereas social factors are of great importance in spread (cf. Guy, Pintzuk, and Wolfram and Schilling-Estes, this volume), they are of little or, maybe, even no importance in certain types of change which are subsumed under the term grammar-initiated change.

2 Universal, System-Independent Morphological Naturalness/Markedness

This subtheory is a preference theory (cf. Vennemann 1983; Dressler 1999), which establishes deductively degrees of universal preferences on a restricted number of naturalness parameters. Here naturalness refers specifically to what is universally preferred on one given parameter. Parameters and their preference degrees are deduced from their extralinguistic bases.

For each parameter, the two main diachronic predictions are:

- i the more natural a phenomenon is on a given morphological parameter, the more stable, that is, the more resistant it should be to morphological change (but not necessarily to phonological or syntactic change);
- ii if, of two comparable morphological options X and Y, X is more natural than Y on a given parameter Z, then natural/unmarked change of X to Y should be more likely to occur than the reverse, unnatural/marked change Y to X. This predicted direction of change does not imply the absurd position of overall change toward more and more naturalness, but represents the hypothesis of local improvement on just one parameter (cf. Vennemann 1990), which goes back to Jespersen's (1949) idea of local efficiency of change (more in sections 2.2 and 4.2 below).

Empirical testing of the predictions of (i) and (ii) should reach statistical significance (weak hypothesis) or they should even predict the default (strong hypothesis).

2.1 Universal naturalness parameters

Iconicity is the best-known semiotically derived parameter. Most important for morphology is its subparameter of constructional iconicity (cf. Mayerthaler 1981). According to Peirce's (1965) subdivision of icons, the various types of English plural formation can be classified as follows: *oaf-s* is diagrammatic, that is, most iconic, because there is an analogy between morphotactic addition of a plural marker and addition of the morphosemantic feature of plurality; umlaut plural *feet* with vowel modification (from *foot*), instead of addition, is only metaphoric (i.e., with weaker iconicity); *loav-es* (from sg. *loaf*) lies in between; *sheep* is non-iconic; the counter-iconic operation of subtraction can be illustrated with subtractive plural *hon* of sg. *hond* 'dog' in a Franconian German dialect: naturalness decreases accordingly on this scalar parameter of constructional iconicity.

If we test the predictions (i) and (ii) of section 2 with recent diachronic change, then the diagrammatic type *oaf-s* is the only productive and stable one

in English. It acquires new items from the type *loav-es*, as attested by the variation *roof-s/roov-es*, cf. *leav-es* versus *The Toronto Maple Leaf-s*; similarly the umlaut plural *lice* has a recent variant *louse-s* (with new meaning and diagrammatic plural), and, earlier on, pl. *cyne* has been replaced by *cow-s*; the anti-iconic Franconian plural type *hon* has become unproductive and loses items to diagrammatic additive plural formation.

From the semiotic preference for transparency, the two parameters of morphosemantic and morphotactic transparency² are derived: on the parameter of morphosemantic transparency, full transparency means fully compositional meaning, as is generally the case with inflectional meanings. For example, the meaning of *cow-s* equals the meanings of *cow* and of plurality. There is, however, morphosemantic opacity in cases of parasitic formation (cf. Aronoff 1994: 33), such as in the formation of the Latin periphrastic future *canta-t-urus sum* 'I'll sing,' formed via the stem of the past participle *canta-t-us*, whereas there is no meaning of past in the periphrastic future. Since, in general, there is an iconic preference for a pairing of transparent meaning and form, this morphosemantically opaque periphrastic future of Latin has been replaced by more transparent ones in the Romance languages, especially the type Fr. *chanter-ai*, Sp. *cantar-é*, etc., which still shows its origin from Inf. (Lat. *cantare*, Fr. *chanter*, Sp. *cantar*) and the auxiliary Lat. *habeo*, Fr. *ai*, Sp. *he* 'I have.'

On the parameter of morphotactic transparency, the most natural forms are those where there is no opacifying obstruction to ease of perception. Purely phonological processes opacify very little, for example, phonological surface palatalization in the Polish pejorative nom.pl. *Polak-i* of sg. *Polak* 'Pole.' More morphotactic opacity occurs in the frequent intervention of morphonological rules, such as in Polish morphonological palatalization, for example, normal nom.pl. *Polac-y*. Most opaque is suppletion, as in E. *am, is, are, was*. Diachronically, opaque forms are less stable than more transparent ones and easily replaced, unless high token frequency facilitates memorization of opaque forms and hence helps to preserve them. Thus in English and German, morphotactically opaque strong verbs have been increasingly replaced by transparent weak verbs.³ Most resistant to change are the very frequently used auxiliaries, modal verbs, etc.

Another way of rendering plurals more transparent (and often more iconic) is hypercharacterization (cf. Malkiel 1957), similar to children's plural *feet-s*, where a morphological category is doubly marked, the second time in a more iconic and/or transparent way. Diachronic examples are Middle English pl. *child-er/child-re* > *child-ren*; comparative *worse* > colloquial *wors-er*.

A consequence of the preference for morphotactic transparency is also the preference for continuous (rather than discontinuous) elements. Therefore suffixation and prefixation is preferred over infixation (discontinuous base) or circumfixation (discontinuous affix). The diachronic instability of infixes is evident in the history of Indo-European languages: for example, *-n-* infixes of the Latin present stem, as in *fra-n-g-o* 'I break,' perfect *freg-i*, past participle *frac-tus*, have become part of the immutable verb stem, as in It. *frang-o, fransi, franto* (cf. Klausenburger 1979: 49–54). Also, diminutive/hypocoristic suffixes

are generally preferred to comparable infixes, such as in Sp. *Cesar-ito* versus *Ces-ít-ar*, hypocoristics of the name *Cesar* (cf. Méndez Dosuna and Pensado 1990), from the late Latin suffix *-ittus*.⁴

Related to the preference for morphotactic transparency is also the word-base preference (cf. Dressler 1988b): the most natural base of a morphological rule is a word, because this is, in semiotic terms, a primary sign and thus a very transparent unit. Smaller bases (stems, roots) or more complex bases (phrases, sentences) are dispreferred. This makes, among the two German plural variants of *Pizza*, word-based *Pizza-s* more natural than root-based *Pizz-en*. As predicted, the type *Pizza-s* is now the preferred one (cf. Wurzel 1984; Janda 1991, 1999a, with extensive literature).

The word-base preference also renders compounds like *do-it-yourself movement* (with a sentence as first member) less natural than *eye movement* (where the first member is a word). Such sentence-based compounds seem to originate only in literary languages as marginal neologisms or often only occasionalisms (ad-hoc/nonce formations) and are socioculturally motivated, relatively unnatural complications, which may be compared to the rise of complicated politeness forms.

A similar motivation can be found for violations of the binarity preference: grammatical relations are preferentially binary (based on the binary nature of neurological information transmittance). In syntagmatic relations, the preferred patterning consists in concatenating one element to one base. This preference holds, for example, for compounding, including coordinate/copulative compounding, as in *queen-mother* or *prince-consort*. This preference is violated, due to entirely extralinguistic reasons, in denominations of flags, for example, *red-white-red* for the Austrian and Peruvian flags. Similarly, Sanskrit coordinate compounds start to have more than two members only in later, stylistically marked texts or due to extralinguistic reasons, as in the denomination of the four main castes *brāhmaṇa-ksatriya-viṭ-śūdrāḥ* 'the set of brahmins, warriors, Vaiśyas, Śudras.'

The preference parameters of bi-uniqueness (uniform symbolization), indexicality, and optimum shape/extension of morphological word forms will be dealt with in sections 2.2, 3 and 4.

2.2 Conflicts between universal parameters

Unnatural/marked changes can be partially explained by recourse to conflicts between parameters either of the same grammatical component (here morphology) or of different components (morphology versus phonology/syntax). Let us start with morphology-internal parameter conflicts.

First, we must introduce another parameter derived from Peircean semiotics, the parameter of indexicality. On this parameter, adjacency is preferred to distance, both syntagmatically and in terms of rule application. This favors the diachronic change of rule telescoping (cf. van Marle 1990: 270; Dressler 1996a: 97), insofar as the morphological surface form can be immediately derived

from the base instead of having to be preceded by intermediate rules and false steps. An example is the genesis of German circumfixes, as in the poetic occasionalism *Ge-khaki-t-e* 'having a khaki-colored uniform' (= GIs, Arno Schmidt). The intermediate steps are: noun *Khaki* → verb **khaki-en*, past participle suffixation of this verb → **khaki-t*, prefixation → **ge-khaki-t*, conversion of past participle → adjective. Rule telescoping allowed direct derivation of the adjective from the noun via circumfixation and a morphosemantically transparent relation between nominal base and derived adjective. This, however, created the class of morphotactically opaque circumfixes.

Another, better-known, semiotically based parameter consists in the preference for bi-uniqueness, or at least uniqueness, as opposed to ambiguity. Bi-uniqueness⁵ holds if one and the same form has always the same meaning and vice versa, uniqueness if this holds in only one of the two directions. Bi-uniqueness is difficult to achieve because of economy of sign shapes and is thus often violated, for example in cases of hypercharacterization (see section 2.1), where one and the same meaning, for example plurality, is expressed twice instead of once only. In hypercharacterization, morphotactic transparency wins out over bi-uniqueness.

Since conflicts between parameters of morphology and those of either phonology or syntax are dealt with, albeit from a different perspective, in Janda's and Joseph's contributions to this volume, my discussion can be limited to indicating specifics of the naturalist approach.

In interaction with phonology (cf. Dressler 1985b, 1996), in a first stage, sound laws apply with little or no respect for morphology. These purely phonological processes (postlexical, postcyclic rules in the terminology of Kiparsky's Lexical Phonology) opacify morphotactics very little, as in the surface palatalization example from Polish, in section 2.1. Similarly, more morphotactic opacity occurs when morphonological rules intervene, as in the morphonological palatalization example in Polish. This increasing morphologization of phonological rules represents, on the one hand, an unnatural/marked change on the parameters of morphotactic transparency and constructional iconicity (cf. section 2.1) as well as on the parameter of phonological (bi-)uniqueness, because Polish [k'] uniquely derives from underlying /k/, whereas [c] may derive from either /c/ or /k/. On the other hand, a context-sensitive phonological process possesses much phonological indexicality (since it refers to its phonological context) and little morphological indexicality (since it refers to a following suffix), whereas for morphonological rules morphological indexicality is much more important than phonological indexicality, and morphological rules possess only morphological indexicality. Thus increasing morphologization of phonological rules represents a shift from phonological to morphological indexicality, explainable by semiotic priority of morphology over phonology. This explains the unidirectionality of change from phonological to morphological rules (cf. Dressler 1996). The questions of the conditions under which natural change of indexicality may outweigh unnatural change on several other parameters will be reconsidered in sections 3 and 4.

A similar approach applies to interaction with syntax and to unidirectionally increasing grammaticalization from syntax to morphology, a natural change on the parameters of morphotactic transparency (continuous forms are preferable to discontinuous ones) and of indexicality, insofar as fixed morpheme order is preferable to alternating order of words or clitics, as in the contrast between periphrastic constructions of the type *I was read-ing*, *Wasn't I read-ing?* and their Italian equivalents *Legge-v-o*, *Non legge-v-o?*

Morphologization of phonological and syntactic patterns has been understood as the basic source of morphological patterns by Wurzel (1984: 102ff, 212, 1987: 69) in his claim that truly morphological change is only reactive (criticized by Dressler 1997a, 1999). Of diachronic relevance is also Wurzel's (1996a, 1996b) perspective on "the age of morphological constructions," which is correlated to stages of development with different properties on morphological parameters.

3 Type-Adequacy

Inspired by Skalička's (1979) views on ideal language types which consist of properties which favor (or disfavor) one another, we can reinterpret language types as (alternative) sets of consistent responses to naturalness conflicts (section 2.2).⁶ Since not all of the most natural options on all parameters can be combined within one language, naturalness on certain parameters must be, so to say, sacrificed for greater naturalness on others (cf. Dressler 1985a, 1985c, 1988a; Sgall 1988). Thus the agglutinating type (as best represented by Turkish) has the advantages of much constructional iconicity, morphosemantic and morphotactic transparency, and bi-uniqueness, but deviates with its often very long word forms from the optimal shape of morphological words (one prosodic foot – another universal preference) and does not fully achieve fixed morpheme order (unnatural on the parameter of indexicality), whereas the opposite holds for the inflecting-fusional type. In this way, universally rather unnatural options may be typologically adequate if they fit the properties of the respective language type.

A morphological change is type-adequate if one of the two following conditions is met:

- i change does not modify typological properties – this is a typologically conservative change;
- ii change correlates with other changes which implement an overall typological change of the respective language – this is a typologically innovative change.

The second type of change can be exemplified with correlated changes from Latin to Romance inflectional morphologies, that is, from a strong inflecting

language to weak inflecting languages (with a greater role for the isolating language type). Also, Estonian has changed from an agglutinating type to a predominantly inflecting-fusional language, with less constructional iconicity, morphosemantic and morphotactic transparency, and (bi-)uniqueness, but with fixed morpheme order and greater approximation to the optimal shape of morphological words (di- and trisyllabicity), when compared with Finnish.

Type-adequacy affects the solution of conflicts between parameters. In section 2.2 we have discussed morphologization of phonological rules and the question of why unnatural change on the parameters of morphotactic transparency, constructional iconicity, and (bi-)uniqueness can be outweighed by other factors. This happens especially in languages of the inflecting-fusional type where naturalness on these parameters is sacrificed in favor of naturalness on other parameters, such as indexicality. In other words, relative unnaturalness on these parameters obtains little weight and can therefore be outweighed by greater naturalness on the parameter of indexicality. Similarly, the morphologically fairly unnatural class of infixes (section 2.1) originates due to phonological factors and is typologically restricted (cf. Moravcsik 1977; Méndez Dosuna and Pensado 1990).

Also suppletion, the most unnatural option on the parameter of morphotactic transparency, originates in inflecting-fusional rather than in agglutinating languages. The many origins of suppletion (cf. Ronneberger-Sibold 1990) must be strictly differentiated from the factors of maintenance (i.e., stability) of suppletion: those suppletive forms are best preserved which have high token frequency (thus storage is more economical than composition and decomposition by rule, e.g., with auxiliaries), have idiosyncratic meanings (e.g., learned connotations, such as Fr. *Fontainebleau*, adjective *Bellifontain* of artificial humanistic origin), are not natural members of large classes (e.g., auxiliaries in contrast to main verbs), or support each other analogically, as in antonyms (e.g., *good*, *bad*, comparatives *better*, *worse*).

4 System-Dependent Naturalness

4.1 System-adequacy

Language-specific, system-dependent naturalness, as conceived by Wurzel (1984) for systems of inflectional morphology (modifications in Dressler 1997b), represents what is normal or system-congruous (system-adequate) within the morphology of a language, even if it contradicts some universal morphological preference. Among competing system-defining structural properties the most dominant is the most adequate one. Wurzel defines dominance basically by type frequency, Dressler by productivity.

One type of change in system adequacy is then change in productivity, either emergence and increase or decrease and loss of productivity. Both subtypes

can be exemplified with the Slavic 1.sg.present marker *-m*: this Indo-European ending of athematic verbs (productive in Old Indic, Greek, Hittite, etc.) was restricted in early Slavic to a small number of high-frequency verbs. From there it spread in many Slavic languages (cf. Janda 1996) and became the only productive ending in Serbo-Croatian, Slovene, etc. In Polish, it became the marker of one productive verb class (of seven productive classes), for example *koch-a-m* 'I love.' This Polish class, however, lost much of its productivity in the twentieth century (Czech even more so). Such changes in productivity, so far, have found only partial explanations (cf. Dressler et al. 1987: 87–92, 108, 113–14, 127–37, 143–6).

4.2 *Universal versus typological versus system-dependent naturalness*

One may understand type-adequacy (section 3) as a filter and elaboration on universal naturalness (section 2), and language-specific system-adequacy (section 4.1) as a filter and elaboration on type-adequacy. Each lower-level filter can specify and even overturn preferences of the preceding higher-order level (cf. Dressler et al. 1987; Bittner 1988; Wheeler 1993).

Let us apply this conception to the development of the genitive singular masculine in Greek. Since the nominative is the base form throughout the history of Greek, the most natural option on the parameter of constructional iconicity is to express the genitive via addition or at least through a longer form than that of the nominative. This has always been the case in productive feminine classes, more so in Modern Greek (MGk) than in Ancient Greek (AGk), for example AGk = MGk nom. *xôrā*, gen. *xôrā-s* 'land,' AGk nom. *mētēr*, gen. *mētēr-ós* 'mother' > MGk nom. *mitéra*, gen. *mitéra-s*. In the masculine, a diagrammatic type AGk nom. *patēr*, gen. *patr-ós* 'father' contrasted with a counter-iconic, but more productive type nom. *páppos*, gen. *pápp[u]* 'grandfather.' The second, more system-adequate type extended at the cost of the first, thus MGk nom. *patéras*, gen. *patéra*, that is, in all productive types of masculines and feminines, it has become system-adequate that nominative and genitive singular are marked in strictly opposite ways (zero versus *-s*, cf. Seiler 1958; Dressler and Acson 1985; see also Joseph 1983b on the question of the origin of the Modern Greek *patéra*-type genitive).

There is, however, no overall priority of system-adequacy, because, as we have seen, diachronic change may also change system-adequacy. For example, the emergence of circumfixes in German (section 2.2) introduced a previously system-inadequate pattern, albeit a type-adequate one. The same could be said about most innovative categories.

Finally, we can study the lack of the filters of type- and system-adequacy, which exist only for grammar but not for extragrammatical or expressive morphology (cf. Dressler and Merlini Barbaresi 1994). Because of the absence of these filters, universal preferences should remain more intact in extragrammatical

morphological operations than in comparable grammatical ones. This can be tested with grammatical reduplication versus extragrammatical echo-word formation (cf. Mayerthaler 1977). Extragrammatical reduplication in echo-word formation (e.g., *zig-zag*, *tick-tock*) is in two ways more iconic than grammatical reduplication, as, for example, in the Latin perfect *cu-curr-i/ce-curr-i* 'I ran' from present *curro*: (i) reduplication is more complete in echo-words, and (ii) there is diagrammaticity between repetitive meaning and repetitive form in echo-words and metaphoricity between change of direction in the meaning of *zig-zag* and change of its vowels, whereas there is no iconicity between meaning and form in the Latin perfect. This allows the following prediction for diachronic change: if an extragrammatical operation is grammaticalized and thus becomes subject to the filters of type- and system-adequacy, then the role of universal preferences should be diminished. This is true for Old Indic intensive formation, which presumably is of extragrammatical origin (similar to echo words). As we can see from forms such as *mṛj-ati* 'wipes' → intensive *mar-mṛj-anta*, there is more repetitiveness in its reduplication than in the form of the perfect *ma-mārj-a*, but less than in echo words. Also there is some iconicity in form–meaning relation (intensification), more than with the perfect, but less than with echo-words (iteration).

5 Change Initiated by Grammar-External Factors

Although most work on diachronic morphology has been directed to grammar-initiated change (sections 1–4), there has also been some work on other types of morphological change, which should be briefly mentioned (cf. Dressler 1997a).

Relevant results in work on contact-induced change (e.g., Dressler and Acsón 1985; Stolz 1987; Boretzky 1995) are that morphological borrowing may violate system-adequacy (and even type-adequacy) by introduction of new morphological patterns and create more allomorphy, that is, more ambiguity (violation of (bi-)uniqueness). When these loans are integrated, however, they may contribute to greater naturalness on some parameters, for example, constructional iconicity via hypercharacterization (cf. section 2.1), as in Megleno-Romanian verb inflection (Boretzky 1995): 1st and 2nd sg. prs. endings *-u*, *-i* have been amplified by adding the respective Slavic endings *-m*, *-š*, as in *afl-u*, *afl-i* 'I, you find' > *afl-um*, *afl-iš*.

Both interference and internal reduction have been shown to fit naturalness criteria in studies of language decay and language death by Dressler (1991 and before). The, so-to-say, inverse expansion of morphology in the development of creole languages delivers evidence supporting the relevance of naturalness parameters, as shown for word formation by Mühlhäusler (1990) and for inflectional morphology by Thiele (1992).

In consciously planned language change, universal preferences play a role in terminological innovations in word formation. Terminographers aim especially

at high morphosemantic and morphotactic transparency, constructional iconicity, and bi-uniqueness within the same text world, for example, the same school-specific specialist discourse (cf. Felber and Budin 1989).

6 Concluding Remarks on the Explanation of Morphological Change

As I have argued in Dressler (1995, 1997a, 1999), functional explanation in terms of Natural Morphology so far has achieved the grading of preferences and thus probability of types of morphological change in relation to sets of conditions. Certain types of dysfunctional change have been identified, which comes close to the definition of impossible change. Change has been related to language acquisition (cf. Aitchison, this volume). For this relation I have proposed the framework of constructivist self-organisation (Dressler 1995b, 1997a), which has been independently proposed for language change by Ehala (1996). The combination with functional explanation via preferences has the advantage of tackling probability of change and thus, at least indirectly, the boundaries between possible and impossible change.

NOTES

- 1 Cf. Kilani-Schoch (1988); Dressler et al. (1987); Luschützky (1991); Carstairs-McCarthy (1992: 215–40); Tonelli and Dressler (1993); Wurzel (1994a).
- 2 Mayerthaler (1981) and Wurzel (1984) have a different terminology; they use “morphological (formal) transparency” instead of “morphotactic transparency” and “morphosemantic transparency” as the hyperonym of both of my parameters of morphosemantic and morphotactic transparency.
- 3 For recent systematic investigations in terms of NM, see Bittner (1996) and Bloomer (1994).
- 4 Why such morphologically relatively unnatural phenomena come into existence at all is due to forces outside morphology; see sections 2.2, 3, and 4.
- 5 Also called the One-Meaning-One-Form Principle, relational invariance, or preference for uniform symbolization (Mayerthaler 1981) or for unequivocal recoverability; cf. Anttila, this volume.
- 6 Actual language systems, obviously, can only approximate ideal language types, and they do that differently in different parts of morphology. Thus English has a nearly isolating inflectional morphology (more so in nouns than in verbs), an inflecting-fusional derivational morphology of Latinate origin, and properties of the polysynthetic-incorporating type in compounding.

13 Morphologization from Syntax

BRIAN D. JOSEPH

It is clear that the set of changes effected by speakers in their languages include those that are often labelled “grammaticalization,” “grammaticization,” or even “grammatization.” This notion is variously defined,¹ but especially in recent years, almost always in such a way as to refer to something that, first of all, morphemes do, as opposed to (referring to) what is done by speakers, and that, second, echoes the characterization of Kuryłowicz (1965: 52): “an increase of the range of a morpheme advancing from a lexical to a grammatical or from a less grammatical to a more grammatical status.” Indeed, several other chapters in this volume – those by Bybee, Fortson, Harrison, Heine, Hock, Mithun, Rankin, and Traugott, to be exact – are concerned, to one degree or another, with grammaticalization.

As Heine’s chapter points out, the notion of “grammaticalization” has been extended by many practitioners to cover other sorts of change than strictly the movement of an item along a scale (“cline”) of increasing grammatical status (from content word > grammatical word > clitic > inflectional affix, cf. Hopper and Traugott 1993: 7), and thus Kuryłowicz’s definition is probably too narrow. McMahon (1994a: 160), for instance, notes that grammaticalization encompasses essentially all types of language change, since “grammaticalization is not only a syntactic change, but a global change affecting also the morphology, phonology and semantics.”² Still, Kuryłowicz’s definition is generally accepted as a basic characterization of grammaticalization, and it is so endorsed by Heine (this volume).

In the present chapter, by contrast, a rather different angle on the emergence of grammatical elements and related phenomena is taken. In particular, the focus here is on what can be called “morphologization,” in a particular sense – a set of developments by which some element or elements in a language that are not a matter of morphology at one stage come to reside in a morphological component – or at least to become morphological in type³ – at a later stage.⁴ For example, within Romance linguistics⁵ it is generally agreed that the French adverb-forming suffix *-ment*, as in *clairement* ‘clearly’ (cf. *clair*

'clear/MASC.SG'), is a reflex of the ablative case of the Latin feminine noun *ment-* 'mind' (nominative singular *mens*) as used in adjective + noun phrasal combinations serving as adverbials, for example, *clarā mente* 'with a clear mind' (where *clarā* is an ablative singular feminine form agreeing with the noun it is modifying); a reanalysis and/or shift in phrasal status to word-level status seems to have occurred, resulting in monolectal forms in French such as *clairement*.⁶ Thus what was once in Latin a matter of syntax, that is, a combination of free words forming a noun phrase that was case marked so as to function adverbially, became in French a matter of morphology, that is, the output or result of word-formation processes that yield a derived word. But this case is also a stock example of grammaticalization (see Hopper and Traugott 1993: 130–1), so some differentiation between grammaticalization and morphologization is needed in order to show their distinctness (as in Gaeta 1998, for instance).

Thus, the goal of this chapter is to discuss various aspects of morphologization, especially in comparison with the by-now more familiar notion of grammaticalization, and to present an extended case study examining one example in some detail. The case in point is the change in Medieval and Modern Greek by which earlier speakers' use of a periphrastic (i.e., multi-word and thus syntactic) future-marking formation, consisting of the verb *thélō* and a complement verb, yielded to later speakers' use of a monolectal future in the modern language – one with an apparently prefixal marker [θa-] attached to an inflected verb form. Meillet (1912) wrote about this case as a paradigm example of grammaticalization, and it has been mentioned elsewhere in the grammaticalization literature, as well (e.g., Hopper and Traugott 1993: 24; McMahon 1994a: 167).⁷

1 Scope and Motivation for Two Types of Morphologization

There are two directions for morphologization: either something that is syntactic at one stage can turn into morphology (the major focus of this chapter), or something that is a matter of phonology at one stage can become morphological (as discussed by Janda, this volume). These directions could be characterized as morphologization from above and morphologization from below, respectively, reflecting the customary view of the components of grammar as hierarchically arranged from the level of sound "up to" the level of sentence structure, though nothing crucial hinges on this characterization.

Elsewhere, in Joseph and Janda (1988), these two types of morphologization have been referred to as *desyntacticizing* and *dephonologizing*, respectively. Although they can be given these different labels, they are actually quite similar, having the same outcome, that is, morphology, and the same motivation.

In particular, both reflect a preference on the part of speakers for what Joseph and Janda refer to as "localized" solutions to the problem of how to account for a given phenomenon in language, for example, marking for some

category or a particular combination of elements. “Localized” solutions range over small sets of data rather than being widely applicable, and are general only in a very local sense, covering perhaps just a few forms. Reduplication in Sanskrit provides examples of such local generalizations, since the patterns of reduplication found, for instance, in the perfect tense formations, including (where V = a vowel that usually copies the root vocalism) V-, VV-, CV-, and occasionally even CVV-, as well as the highly specific *ān-*, tend to cluster around particular root types, such as V- with roots that begin with *v-*, *ān-* with certain vowel-initial roots, CV- with alteration of the root-initial consonant with a handful of roots, CV- as the default case, and so on. Significantly, also, local generalizations tend to result from, and show fragmentation of, once quite general phenomena – perfect tense reduplication in Proto-Indo-European, for instance, was almost exclusively⁸ CV- – and thus they suggest that speakers focus on the analysis of just a restricted set of data at a time, and therefore come up with quite particularized analyses.⁹ That is to say, speakers view language through a relatively small “window” at any given time, and thus the size of their focal area is relatively small.¹⁰ This access to only limited data at a given time translates into solutions that are cast in terms of highly particular properties of stems, affixes, and the like, and which are usually best accommodated in the morphology, since phonological solutions are usually to be interpreted quite generally, referring as they do to properties of sound only; thus local generalizations, being defined often in terms of idiosyncrasies and sometimes extending only over a few forms, are usually morphological in nature, as well as quite concrete, in that they are based on surface representations and categories that are overtly marked rather than on abstract properties of phonological form.

In that way, Joseph and Janda claimed, speakers opt for morphological accounts over phonological or syntactic ones whenever the analysis of a given phenomenon offers any ambiguity as to the extent of its generality. It was further argued there that grammars should therefore be viewed as being “morphocentric,” or more accurately, “morpholexicocentric” (see below), with a greater role for the morphological component, in order to explain this preference speakers give to morphological accounts.

It must be realized that the lexicon is taken here to be connected closely with the morphological component, and thus is part of what is to be considered “the morphology” of a language. The lexicon, after all, is where (at least root) morphemes are found and where (at least) idiosyncratic information about morphemes resides.¹¹ Thus references to “morphological” phenomena here include “morpholexical” information as well. Morphology, after all, is concerned with form and the relation of form to meaning in most traditional views,¹² so any aspect of language that is concerned with form, as the lexicon must necessarily be, is fair game for being subsumed under – or at least tightly allied with – morphology. Moreover, in many frameworks, even elements with internal syntax are listed in the lexicon, for example, adjective–noun combinations with specialized meanings such as *Cold War*,¹³ a move that is in keeping with the

expanded view of the role of morphology and the morphological/morpholexical component in language implicit in the notion of “morphocentricity.”¹⁴

The scope of morphology can thus be quite large, and consequently there is a wide range of phenomena that can be said to show morphologization, that is, movement into the morphology, assuming of course that one can devise a heuristic for determining when the boundaries have been crossed (see below, section 3).

2 Morphologization and Grammaticalization Distinguished

As noted at the beginning of this chapter, there is some overlap between the notion of morphologization as developed here (drawing on Joseph and Janda 1988) and that of grammaticalization, discussed in this volume and elsewhere. Yet, there are significant differences of approach, method, and substance between the two that provide a rationale for taking a morphologization viewpoint on various changes and not simply treating them as instances of grammaticalization.¹⁵

For one thing, there are phenomena in language which are (already) clearly grammatical in their function but which nonetheless undergo changes in the direction of greater involvement in the morphological component. For instance, the changes to be discussed concerning the Greek future started with a grammatical usage of the verb *thélō*, which meant ‘want’ as an ordinary lexical verb, in a periphrasis indicating futurity; as becomes clear below, these changes were such that the realization of the marking for futurity passed from being a matter of syntax (i.e., word combination) to being a matter of morphology (i.e., word formation).

Thus, there is clearly morphologization in this example by the definition given above, but is there grammaticalization? There might be, but only if grammaticalization is taken to involve movement along a “cline” by which expression via morphology, for example with an affix, is “more grammatical” than expression via syntax (cf. Kuryłowicz’s definition, given above). However, such a cline is completely stipulative, for there are free words that have grammatical functions, such as English *of* or French *de*, various complementizers such as English *that* and *whether* or French *à*, pronouns, etc., as well as affixes that have no grammatical function at all, such as the empty *-al* that (descriptively speaking) can be added for some English speakers to *syntactic* to form *syntactical* (note that both are adjectives and that they are synonymous) or the equally empty *-y* that (again from a descriptive standpoint) some English speakers add to *competence* to give *competency*, and so on. Thus there is no necessary correlation between an item’s place on the cline and its degree of grammatical involvement. Grammaticalization theorists recognize this issue to some extent; Lehmann (1985: 306), for instance, gives six criteria – attrition, condensation,

paradigmaticization, coalescence, obligatorification, and fixation¹⁶ – and claims that an item lines up at equivalent points with regard to each one as it “grammaticalizes.” However, each of these properties is in principle independent of the others, so that demanding a grouping of all of them involves a stipulation that one needs to have all six, and in equal measures, to have movement along the grammaticalization cline.

Similarly, as noted in section 1, there are two directions of development that can lead to morphologization, and desyntacticizing morphologization can readily be linked to dephonologizing morphologization via their common outcome (morphology) and common motivation (localized generalization by speakers). When viewed from within a grammaticalization framework, however, it is not at all obvious why morphological/morpholexical determination for a given phenomenon, as opposed to determination via regular and general phonological conditions, should be considered to be more grammatical and thus should have anything to do with or anything in common with, for instance, the movement from syntactically determined to morphologically/morpholexically determined. For example, marking noun plurals via an affix that happens to have a regular, exceptionless, phonological effect on a root, such that it would be accounted for by a purely phonological rule, does not seem *a priori* to be less grammatical in any meaningful sense than marking plural via an affix that alters the vocalism of a root in ways that vary from one lexical item or lexical class to another and thus requires a morpholexically particularistic account;¹⁷ nonetheless, grammaticalization “theory” wants to link such a change in the nature of the concomitant phonological effects with the change from phrasal to affixal expression of adverbials or futures or the like as being the same type of change.¹⁸ Such a linkage is straightforward when viewed from the perspective of morphologization, since in both cases there is greater involvement of the morphology, but not necessarily so at all from a grammaticalization perspective.

Moreover, as noted above, grammaticalization proponents recently have been claiming an ever broader domain of applicability for this notion, whereas such is not the case with morphologization. Yet there are changes in language and grammar that do not involve any of the typical characteristics of grammaticalization. Regular sound change, for instance, under the Neogrammarian view (see Hale, this volume), is purely phonetically conditioned and almost by definition has no grammatical involvement at all. Also, a change such as the polarization in word order by which speakers of English have come to differentiate the perfect *I have written the letter* from the resultative *I have the letter written*, moving away from earlier English variability in ordering for both types,¹⁹ seems not to involve any cluster of the characteristics said to be typical of grammaticalization.²⁰ Admittedly, these changes do not involve morphologization either, but the concept of morphologization makes no claims about such changes, whereas grammaticalization, in some instantiations at least, does.

Similarly, there are changes in the direction of greater morpholexical involvement that do not involve grammar, and thus can be accommodated within the concept of morphologization but not grammaticalization. Relevant here are the

sorts of reductions seen, for instance, in German *heute* 'today' from a presumed instrumental phrase *hiu tagu** in Old High German, or *heuer* 'this year' from the OHG instrumental phrase *hiu jaru*. It is not clear that anything relevant to grammaticalization has taken place, for this combination of sounds is as grammatical (or not, as the case may be) before the phrase was reduced as it is afterwards. Yet, as Hopper and Traugott (1993: 23) note regarding *heute*, "there surely is a difference in Modern German between *heute* and *an diesem Tage* 'on this day' that needs to be characterized in some way"; grammaticalization really does not provide a way, yet morphologization is exactly what is involved here.

In fact, the only way that *hiu tagu* > *heute* might be said to be relevant to grammaticalization is under the interpretation Hopper (1994) makes concerning what he calls "phonogenesis," defined by him as "the process whereby new syntagmatic phonological segments are created out of old morphemes" (p. 31). He explicitly refers to phonogenesis as "an advanced stage of grammaticalization" (ibid.), noting that there is generally "phonological reduction that accompanies grammaticalization" (ibid., and see the reference above in section 2 to Lehmann's "attrition" and "coalescence"). While there is no denying that such developments occur – and indeed, Hopper presents a large number of well-known and not-so-well-known cases, mostly from English, by way of illustrating the phenomenon, such as the *-nd* of *friend* and *fiend* reflecting an old present participial ending now lacking in any obvious meaning – the terminology and definition seem particularly inappropriate and the linkage with grammaticalization is at best fortuitous.

For one thing, there is nothing grammatical about such material; if anything, what *-nd* has undergone might be termed "degrammaticalization," at least by the usual definitions of grammaticalization, for there is a movement out of being, in some sense, a grammatical formative. Admittedly, this criticism may involve taking the terminology of grammaticalization too much at face value, but given generally accepted formulations of grammaticalization, an extension of the notion is needed if "phonogenesis" is to be subsumed under the same rubric as the development of the French adverbial marker *-ment*. Furthermore, calling the accretion of material onto a word "phonogenesis" implies that the material added, the element that was once a morpheme in Hopper's formulation,²¹ had no phonic value when it was a morpheme. However, whether *-nd* was a recognizable participial suffix or a meaningless string at the end of *friend* and *fiend*, it still contained a sequence of sounds; the morphemic or non-morphemic status of that sequence does not affect the extent to which this element adds "phonological bulk" (in Hopper's words, p. 29) to a stem it attaches to. Thus there may be "phono-accretion," but the sounds were already there and thus had already undergone "genesis" at the time they constituted a morpheme; the real difference lies in the morphological status of the sequences in question, that is, phrasal versus word status, or compound/polymorphemic word versus monomorphemic word status. Such a difference can be readily characterized in terms of morphologization, but not grammaticalization, and

moreover, focusing on morphological status allows such cases to be linked rather directly with the emergence of the French adverbial suffix and similar examples in ways that grammaticalization theory can only do by stipulation and extension of the basic notion.²²

Finally, there are methodological differences between the ways in which morphologization has been studied and the ways in which grammaticalization has been studied. In particular, grammaticalization has now been built into an elaborate theoretical framework, so-called “grammaticalization theory,” with a cognitive basis and a stake in the putative principle of unidirectionality, by which, it is claimed, changes are always in the direction of greater grammatical status and not, for instance, in the direction of affix to clitic or free word, that is, in the opposite direction on the cline of grammaticalization. The existence of such “counter-grammaticalizations,” described in the literature for several years and recently discussed and summed up, with extensive literature, in Janda (2001), are particularly troublesome for grammaticalization proponents,²³ but pose no threat for the concept of morphologization, as discussed below in section 5.

Also, grammaticalization studies tend to ignore the somewhat more formal question of where in the grammar a particular phenomenon is to be located, as if it is always self-evident what the answer to this question is. Some studies do provide a basis for making a decision, for example Hopper and Traugott (1993: 4–6) regarding the distinction between clitics versus affixes, etc., but many do not, nor do all that recognize criteria apply them in all cases.

Thus grammaticalization and morphologization indeed offer distinct perspectives on, and represent distinct ways of viewing, changes that involve grammatical machinery and morphological/morpholexical material.²⁴

3 How to Tell

As suggested earlier, talking about morphologization implies that there is a way to tell whether some phenomenon is “in the morphology” or, as is relevant for desyntacticization, “in the syntax” instead. The most useful heuristics are those enumerated in Zwicky and Pullum (1983) and Zwicky (1985a).

They distinguish among affix, clitic, and word as types of morphological elements, drawing important distinctions between affix and non-affix and between word and non-word. “Clitics,” then, are elements that are neither canonical affixes nor canonical words.²⁵ They further identify a number of traits that are characteristic of affixes and characteristic of words. For the most part, affixes, as morphological elements, show various types of idiosyncrasy – they are selective as to what they attach to, they can provoke irregular effects on the stems they occur with, their ordering is generally fixed, they tend to be prosodically dependent, they are not subject to syntactic rules (e.g., deletions) unless the whole word they are part of is affected,²⁶ and the like – while words, as syntactic elements, show a greater degree of generality, being unselective in their

combinatory possibilities, allowing reordering in response to stylistic factors, having prosodic independence, showing a one-to-one mapping with semantic rules that give syntactic units semantic compositionality, etc.

There are other criteria that can be helpful. For example, in the case of the Oscan locative, agreement seems to solve the issue of what sort of analysis is warranted. Oscan innovated a locative by the agglutination of a postposition *en* onto a noun, for example *húrtín* ‘in the garden’ (Buck 1928: 114), yet what shows that this is indeed a morphological marker of a case, as opposed to a combination of free words in a noun phrase that undergo some phonological adjustment, is the fact that the *-ín* ending occurs on adjectives in agreement with a locative noun marked in the same way. Thus, this new locative participates in adjective agreement just like other cases, a feature which shows that the appearance of the *-ín* is not from a synchronic merging of a free word onto a stem; if it were a syntactically generated postpositional word, one would not expect it to occur both on the adjective and on the noun, unless, due to the principle of compositionality, there were a corresponding semantic contribution from both occurrences.

Still unresolved, admittedly, is the issue of whether compounds are syntax or morphology. The case of Romance adverbial *mente*, once again, is instructive. Unlike French, where *-ment* seems to be an affix (note that it is bound and provokes an idiosyncratic selection of the adjective stem it is added to²⁷), Spanish adverbial *mente*, in certain registers at least, can apply distributively over both adjectives in a conjoined phrase (apparently contrary to the lexical integrity principle – see n. 26), for example *rápida y claramente* ‘rapidly and clearly’ (not: ‘*rapid and clearly’) and *-mente* adverbs can have two accents (thus *rápidaménte*). Moreover, *mente* survives in Spanish as a free noun meaning ‘mind,’ though it is not at all clear that there is a synchronic connection between *mente* ‘mind’ and the adverbial formative. These facts suggest an analysis whereby *-mente* adverbs in modern Spanish are compounds, perhaps containing *-mente* as a bound root. If that is the case, then the developments with *-mente* in Spanish would not represent a case of morphologization, unless compounds are taken to be a matter of morphology (word formation) rather than of syntax.²⁸

Still, even though there are unclear cases, the lack of clarity comes from unresolved issues in grammatical analysis and linguistic theory, not from anything inherent in the notion of morphologization itself; once those issues are settled, then their application to the determination of where in the grammar a particular phenomenon is to be located is straightforward.

4 An Extended Case Study: The Medieval and Modern Greek Future

As noted at the start of this chapter, the Greek future offers an appropriate case study, inasmuch as the future marker *θα* of Modern Greek is analyzable

as a prefix, that is, an element of morphology, yet its ultimate source in earlier stages of Greek was a periphrastic – multi-word, thus (presumably) syntactic in nature – expression consisting of the verb *thélō*²⁹ (meaning ‘want’ as a lexical main verb) plus a complement verb.³⁰

Some examples of the future in Modern Greek include:

- (1) a. *θα γράφο*
FUT write/1SG
‘I’ll be writing’
b. *θα σου γράφο*
FUT you/GEN write/1SG
‘I’ll be writing to you’
c. *δεν θα γράφο*
NEG FUT write/1SG
‘I won’t be writing’
d. *δεν θα σου γράφο*
NEG FUT you/GEN write/1SG
‘I won’t be writing to you’

This future marker in the modern language is best analyzed as a true prefix, based on the criteria for classification in Zwicky and Pullum (1983) and Zwicky (1985a). In particular, it is a bound element, unable to stand alone and generally unaccented. More specifically, *θα* is affixal since it shows two properties more usual of affixes than of clitics or free words: a fixed position – **γράφω θα*, **θα δεν σου γράφο* and other permutations of the elements in (1) are all ungrammatical – and selectivity, since it attaches only to verbs. Furthermore, like affixes, but not (generally speaking) clitics, *θα* shows some idiosyncratic behavior. For instance, it triggers for some speakers idiosyncratic voicing on third person weak pronouns that follow it, so that these forms, which otherwise occur with initial [t-], can be pronounced with [d-] after *θα*, e.g. [θa do γράφο] ‘I’ll be writing it’ (Householder et al. 1964). In addition, *θα* shows some special combinations with a few verbs, contracting for instance with forms of the verb ‘be,’ for example /*θα + ίσε/* ‘you will be’ → [θάσε], even though the contraction of *a + i* is not a general phonological process in Greek – the *-a* of the adverb *kalá* ‘well’ combines with *ίσε* to give [kalájse] not *[kaláse] ‘are you well?’ for instance. Finally, *θα* shows idiosyncratic semantics in the expression *τί θα πει?* ‘What does it mean?’ (literally: ‘What will it-say?’). All of these characteristics taken together indicate that for Standard Modern Greek at least, the future marker is an affix.

However, as noted above, the future marker was not always an affix; the ultimate source of *θα* is the verb of volition *thélō* ‘want,’ which occurred in Classical and early post-Classical Greek as a main (lexical) verb with a complement infinitive, as in (2):

- (2) *thélō gráphein*
want/1SG write/INF
‘I want to write’

In later post-Classical Greek, the infinitive gave way to a finite clausal replacement introduced by the subordinator *hína* 'that,' as in (3), a process that began in the Hellenistic period and spread over several centuries on a construction-by-construction basis (see Joseph 1983a, 1990 for details and bibliography):

- (3) *thélō hína gráphō*
 want/1SG that write/1SG
 'I want to write' (literally: 'I-want that I-write')

The more immediate source for the future prefix *tha* is a "redeployment" of the infinitive with *thélō*, coupled with a semantic shift from the volitional lexical main verb to a more auxiliary-like and grammatical future meaning, as in (4):

- (4) *thélō gráphein*
 1SG write/INF
 'I will write'

As an independent verb at this stage *thélō* still means 'want,' a meaning and use that continues into present-day Greek (though not with an infinitival complement).

At this point, to follow essentially the account of Psicharis (1884) and the chronology for the emergence of various future formations seen in Bănescu (1915) (see also Joseph 1983a, 1990), a chain of developments began which ultimately led to the form *tha*. These developments included regular sound change, reanalysis, and analogical generalization of sandhi variants, among others. The first step was the loss of word-final *-n* in the infinitive by regular sound change,³¹ which resulted in future formations as in (5):

- (5) *thélō grápheī / thélei grápheī*
 1SG INF / 3SG INF
 'I will write' / '(s)he will write'

in which the infinitival complement came to be homophonous with the third person singular indicative form in that both ended in *-ei* (thus, *grápheī* was both 'to write' and '(s)he writes'). At that point, the future formation in the third person seems to have been reanalyzed as a combination of two forms each marked as third person (see Anttila 1972), with the reanalysis being evident when the new pattern with multiple inflected forms was extended into other persons in the paradigm, as in (6):

- (6) *thélō gráphō*
 1SG write/1SG
 'I will write'

This pattern must have coexisted with the infinitival formation of (4), as both types are to be found in one and the same text in Medieval Greek.³² Since the

replacement of the infinitive by finite complementation, seen in (2) and (3), was an ongoing process through much of post-Classical Greek even into the Medieval period (see Joseph 1983a, 1990), it would have affected the renewed use of the infinitive in the future type of (4). This gave rise to an innovative type that was identical to (6) in meaning and similar to it in form except that it had the subordinator *hína* (glossed here, probably inadequately, as ‘that’), and was identical in form to (3) but with a future meaning instead:

- (7) *thélo hína gráphō*
 1SG that write/1SG
 “I will write”

From the future types of (6) and (7), by a change presumably motivated by the elimination of redundant person marking, a type developed with an invariant third person singular form *théli*, which as an independent verb still means ‘(s)he wants’, with no subordinator (from (6) or with the subordinator *na*, from *hína* of (7) by regular sound changes:³³

- (8) a. *théli gráfo*
 3SG write/1SG
 “I will write”
 b. *théli na gráfo*
 3SG that write/1SG
 “I will write”

The next step was that, from (8), a reduction of *théli* occurred, giving *thé*. This reduction may have been a fast speech phenomenon, since it also affected at least some forms of the independent verb ‘wants’ (in present-day Greek, for instance, the second person singular of (non-future) *thélis* ‘you want’ is commonly reduced to *thés* and reductions with other persons and numbers may be possible as well), but it gained currency most generally only with the future marker. Some modern dialects (e.g., Cretan, cf. Pangalos 1955: 322–4) have *théla gráfo* for the future ‘I will write,’ suggesting that the reduction may in the case of (9b) have been via a stage with *thel’na* (elision of unstressed *-i*, and reduction of or assimilation in the resulting *-ln-* cluster). By whatever route, however, the result was the future patterns in (9):

- (9) a. *thé gráfo*
 FUT write/1SG
 “I will write”
 b. *thé na gráfo*
 FUT
 “I will write”

At some point, moreover, *thé* became deaccented, though the chronology of that development is not clear.

Further developments from the formation in (9b) led to the widespread modern form *tha*, usually given as end point of the “grammaticalization” with the Modern Greek future. In particular, *thé na gráfo* of (9b) underwent an irregular vowel assimilation, giving *thá na gráfo*. Here it is relevant that some modern dialects have *thála gráfo* (compare the *théla gráfo* cited above). To get from *tha na gráfo* to *tha gráfo*, it is safest to assume that a variant of *tha na* before a vowel-initial verb, such as *aγorázo* ‘I buy,’ had the form *tha n*, and that this pre-vocalic sandhi alterant was generalized to pre-consonantal position, giving *thá n gráfo*; in this way, no irregular phonological developments need to be assumed, since contraction of *-a a-* to *-a-* is regular in Greek. By a similar path, this variant *thá n* could have yielded *tha* in all contexts – the loss of *-n-* in *tha n gráfo* would be regular, and the resulting pre-consonantal *tha* could then have spread to pre-vocalic contexts, giving forms such as *tha aγorázo* ‘I will buy’ alongside *tha gráfo*.

It is therefore possible to motivate all of the stages by which *thélō gráphein* could have yielded, through the crucial intermediary stage of *thélō (hi)na gráphō*, the Modern Greek future *tha gráfo*. Moreover, with the possible exception of the *thélei (hi)na gráphō* stage, all of the necessary stages are directly attested or safely inferable. Significantly, all of these steps involve, for the most part, perfectly ordinary and well-understood processes in language change: sound change, reduction of redundancy, and (analogical) generalization of one variant at the expense of another.

From the foregoing, it is clear that from the point at which the invariant third person singular form *thélei* ([θéli]) was fixed in the future construction, there was a significant change in the construction. At that point, *thélei* was certainly more grammatical in nature and less lexical, despite the identity in form between it and the third person singular of the main verb of volition “want”; in particular, it was fixed positionally, could not support clitics,³⁴ and could not be inverted, even though in previous stages, there were fewer such limitations on the form of *thélō* in the future. It is not clear when this more restricted *thélei* or its successors developed into a prefix, but clearly *thélei* was a step in this direction.

In terms of morphologization, therefore, at some point between the *théli na gráfo* stage and the *tha gráfo* stage, the expression of the future changed from being a matter of syntax to being a matter of morphology, with a prefix marking futurity. Deciding exactly when that line was crossed would depend on a detailed consideration of all relevant properties of each stage, but most likely it came at a point when the initial part of the future marker (*θ. . .*) was no longer synchronically relatable to the main verb *thél-* that remained in the language. The Zwicky/Pullum criteria allow for a clear determination for the modern language, as demonstrated at the beginning of this section, but the full range of evidence needed for a determination at earlier stages may not be available. Still, from the perspective of morphologization, these developments are readily characterizable.

Within the framework of grammaticalization, however, the view is somewhat different. On the one hand, the development of prefixal *tha* from *thélō hina* looks like a straightforward case of grammaticalization, with an affix developing out

of a once-free form by an eminently traceable progression, and so it is no accident that Meillet drew attention to this in his important early article on grammaticalization. On the other hand, though, it is clear that the combination of *thélō* and a complement verb had a grammatical value marking future quite early on, at a time when the periphrastic nature of the formation and the link between *thélō* in the future and *thélō* as a lexical, main verb would have been obvious. In this view, bearing in mind that the changes from *thélō* (*hi*)*na* to *θa* all involve just ordinary instances of phonetic change and analogy that resulted in increased separation of main-verb *thélō* from what ultimately became *θa*, the latter changes that result in *θa* being a prefix are really incidental to the grammaticalization, rather than forming a crucial part of it that demonstrates that it occurred.

Yet it is well known that speakers can lose sight of obvious connections among elements, so that the increased separation of free form and bound form here does not require the positing of a special mechanism such as grammaticalization. For example, the first part of English *withstand* has become separated off from the preposition *with*, for the original meaning of *with* as ‘against’ is preserved in the compound (literally “stand against”), but is not evident in the free form, as discussed by Kim (1995). Other similar cases involving a separation of forms that were once clearly related include the creation of an innovative gerund *hafing to*, replacing *having to*, based on *hafta* (i.e., *have to*), despite a seemingly clear connection with the verb *have* (Joseph 1992), and *let’s* (discussed both by Joseph 1992 and by Hopper and Traugott 1993: 10–13), which has moved away from its once-syntactic *let + us* source toward morphologicalization as a marker of hortativity. Moreover, in a case especially germane to the matter at hand with *thélei* and *θa*, Pappas (1999) has discussed the increased separation of *thélō* in futures from its corresponding past tense *éthela* in its use to form counterfactuals in Middle Greek.

Therefore, it would appear that one need not invoke “grammaticalization” as the force behind the ultimate formation of a grammatical morpheme for future in Greek. Well-understood processes of change other than “grammaticalization” suffice to give the observed end-result.³⁵ At any rate, however, despite ambiguities as to which stage, if any, is most pertinent to a claim of grammaticalization with the Greek future – the initial innovation by which *thélō* ‘want’ came to be used to mark future or the Modern Greek stage by which future is marked with a prefix – and despite questions about the status of grammaticalization in general and whether or not it has any relevance at all in this case, one cannot overlook the clear indication that morphologization has occurred, in that a once-syntactic expression has come to be analyzable as a morphological expression.

5 Unidirectionality and Morphologization

As noted in section 2, the claim of unidirectional movement along the cline of grammaticalization is an important one within grammaticalization “theory,” and there is much riding on this claim for the theory. In the approach advocated

here, on the other hand, in which the status of an element or phenomenon in its own synchronic grammatical system is at issue, no such claim is made. The reverse of morphologization, referred to in Joseph and Janda (1988) as “demorphologization,”³⁶ taking in both movement from morphology into phonology (“(re)phonologization”³⁷) and from morphology into syntax (“(re)syntacticization”), is acknowledged as a possible development, even if such developments are recognized not to be the norm. In fact, the general procedure used in deciding if morphologization has occurred, that is, the examination of a language in its own (synchronic) terms to see whether a given element or phenomenon is a matter of morphology or of syntax, would dictate that under the right conditions an element that was a bound morpheme at one stage of a language could come to be analyzable as a free word at a later stage.

As discussed earlier, there are in fact several such cases reported in the literature that seem quite compelling.³⁸ Nevis (1986), for instance, has demonstrated that in most dialects of Saame (formerly known as Lappish) an inherited sequence of affixes *-pta-k-ek/n marking abessive has become a clitic word (*taga*, with variant *haga*), and more specifically a stressless postposition, while in the Enontekiö dialect, it has progressed further to become a non-clitic independent word, an adverb, *taga*. A critical piece of the argumentation that *taga/haga* is now a free word is the absence of any phonological interaction (e.g., vowel harmony, or the like) between *taga/haga* and the word it combines with; in the absence of such evidence, the default analysis would treat *taga/haga* as an independent word, not as part of the word it co-occurs with. The particular circumstances by which this element thus came to be analyzable as a word, after being an affix in an earlier stage, are not necessarily ones that would occur frequently, but in a morphologization approach to accounting for *taga/haga*, one has to take what the language gives, so to speak, in establishing the parameters for an analysis, and an element’s earlier status is irrelevant to its synchronic status at some later stage.

An approach to describing and explaining phenomena such as the developments with adverbial *mente* in Romance that is not a straitjacket and does not have to ignore or dismiss viable counterexamples, but rather identifies the (possibly extraordinary) sets of conditions that must be met for such counter-tendencies to emerge and for counterexamples to arise, is in many ways a more realistic framework. Such is the case, it is argued here, with a focus on morphologization, for it can be recognized to be a more realistic approach to understanding changes in morphology and syntax than grammaticalization.

6 More on the Scope of Morphologization

The preceding discussion makes it clear that syntax can develop into morphology. It is reasonable to ask whether “higher” levels can be involved in the devolution into morphology. The answer appears to be yes, in that elements or constructions with a chiefly pragmatically determined value can, under the

appropriate conditions, contribute to a morphological account at a later stage. What is not clear is whether there is an intermediate stage in which a purely syntactic analysis is called for; it may well turn out, though, that such a question is irrelevant.³⁹

A case in point appears to be that described by Auger (1994), concerning the change from subject pronouns to subject-agreement markers in Canadian French through the medium of developments with topic-marking fronted (dislocated) subject pronouns. She argues that the pragmatic effect of dislocation has been lost, so that *Moi, je dors* does not have the topic reading of 'As for me, I am sleeping' but rather only the unmarked reading of 'I am sleeping.' This bleaching of the marked pragmatic function has created a situation in which *je* can be analyzed as a subject affix, since its contribution to the semantic interpretation of the sentence has been usurped by the fronted once-topical pronoun. Indeed, it shows evidence of idiosyncratic behavior, for example in irregular combinations with certain verbs, that is characteristic of affixes. Whether the shift in pragmatic function came first or the idiosyncrasies did is unclear, and the chronology would matter for the determination of whether there was a stage with the fronted pronoun, for example *moi*, and the subject pronoun, for example *je*, but no evidence of affixhood for the latter, that is, a stage at which the positioning of the subject pronoun was still a matter of syntax. If so, then the morphologization evident with subject markers in Canadian French would be just another case of desyntacticization, but if not, and if the idiosyncrasies either preceded or were simultaneous with the bleaching of topicality, then the involvement of pragmatic shifts in morphologization becomes more direct. As always in discussions of where in the grammar a particular phenomenon is to be located, what is most crucial is what the evidence is at the particular synchronic stage under investigation, in this case, contemporary Canadian French. In a sense, then, the question of whether there was a stage where the construction was purely syntactic is not wholly irrelevant, for the current evidence makes it clear that the morphologization occurred, in Auger's analysis, and for present purposes that determination alone may be sufficient.

7 Morphologization/Grammaticalization and Reconstruction: A Caution

One benefit that has been claimed for recognizing grammaticalization is that it can give some guidance in matters of reconstruction (so Rankin, this volume; Harris and Campbell 1995: 361ff). Indeed, if certain types of developments were truly unidirectional, then one could safely infer, given putatively cognate forms in different languages, where one form is a word and the other is an affix, that the language with the affixal form shows an innovation.

If, however, in keeping with the realism that a focus on morphologization requires, unidirectionality is recognized not as a viable absolute of the movement

into morphology but rather as at best a directional tendency, then some caution is in order in applying the findings from investigations into morphologization and grammaticalization to specific problems in reconstruction. Given the hypothetical word-affix cognate situation described above, one could still reconstruct a free word, but there would be greater uncertainty to the reconstruction than if unidirectionality could be relied on absolutely. Indeed, Anderson (1980: 68), in his study of the development of morphology out of syntax, expresses a similar need for caution: "if we have not found that today's morphology can be taken reliably to be yesterday's syntax, we have at least seen that there are some clear circumstances in which today's syntax can be expected to become tomorrow's morphology." But even such expectations need not be realized.

Still, caution is needed, and, to be sure, it is always in order in reconstruction, even in instances that seem to present a quite clear set of facts at first. For example, it is well known that weak forms of pronouns can develop as unaccented variants of strong pronouns, as indicated by the relationship between English *him* and the unstressed form *'im* (phonetically [əm]) and what is known about the history of these forms. Thus, when one observes a similar alternation in the plural, between *them* and *'em* (phonetically [əm]), it is tempting to reconstruct the history of *'em* such that it is derived as a reduction of *them*. Such is not the case, however, for *'em* represents the continuation of the Old English accusative pronoun, but *them* is a borrowing from Scandinavian, replacing the native English pronominal form. The borrowing has created a synchronic situation that looks like the result of grammaticalization, yet the history is quite different. On the other hand, the borrowing can be said to have caused a morphologization in that synchronically, the relationship between *them* and *'em* would be reflected in an enriched lexical entry for *them* listing *'em* as the unstressed variant, inasmuch as there is no regular phonological process in contemporary English that would map between these variant forms; the *them/'em* alternation is unique to this lexical item. Still, however this relationship is encoded in a synchronic grammar, it should be clear that attempting to do reconstruction by "undoing" an apparent morphologization (or grammaticalization, as the case may be) is fraught with potential pitfalls.⁴⁰

8 Conclusion

In discussing morphologization here, I have been critical of many of the assumptions inherent in the study of grammaticalization, in an attempt to distinguish between these two somewhat related concepts. As a final phase of that attempt, I note that the main focus of one interested in morphologization is the perspective of the grammarian, working with the assumption that language does have structure and that this structure must be reflected in our analyses and accounts, and focusing on the place of a given phenomenon in that structural edifice, the grammar of the language. On the other hand, those interested in

grammaticalization generally take the view that language has what may be called “emergent grammar” (see Hopper 1987) in that synchronic structure is a goal that is never reached. This assessment would mean not only that it may not be possible to resolve differences between grammaticalization and morphologization, in that they reflect the results of applying different criteria to a given set of facts about change in a language, but also that recognizing morphologization and all that the notion entails is essential for any structurally oriented historical linguist.

NOTES

- 1 See Janda (2001) for a survey of more than 20 definitions of this term which documents tellingly the general absence from these definitions of references to what speakers do.
- 2 It is worth asking whether grammaticalization “affects” the phonology etc., or whether changes in those components simply constitute or even bring on what is labeled as “grammaticalization”; see Joseph (2001a) for some discussion.
- 3 This implies, of course, that there is a separate – or at least recognizable – morphological rule type, distinct from phonological and syntactic rules. Anderson (1992) argues for this very point, based on the fact, for instance, that morphological formations are subject to different kinds of constraints from syntactic ones.
- 4 Compare the definition given in Hopper and Traugott (1993: 135): “Morphologization involves the creation of a bound morpheme . . . out of an independent word by way of cliticization.” Important earlier works on morphologization from syntax include Givón (1971) (the source of the oft-cited and highly relevant slogan “today’s morphology is yesterday’s syntax” (p. 413)), Anderson (1980), and Andersen (1987).
- 5 See, for instance, Lausberg (1962) for a survey of the Romance evidence, discussed more fully in Karlsson (1981); Hoenigswald (1966: 44) mentions these developments, as do Hopper and Traugott (1993: 130–1).
- 6 Spanish offers an interesting twist on the development of adverbial *mente* in Romance; see section 3 below.
- 7 It has been discussed in the “anti-grammaticalization” literature, too – for instance by Joseph (2001a) (the basis for the present discussion).
- 8 This is assuming of course that the Proto-Indo-European perfect had reduplication – there is at least one widely attested perfect without reduplication, *woyd- ‘know’ (Greek *oída*, Sanskrit *veda*, etc.). Roots with initial sT- (T = a stop) probably reduplicated the whole cluster, to judge from the evidence of Gothic and Old Latin, so also possibly with roots with initial laryngeal consonants followed by a stop. It is not clear what PIE did regarding the vowel of the CV-reduplicand, but most likely it was a prespecified *e.
- 9 Other facts from language change show the same tendency toward locality; for instance, it is quite common for an analogical change to affect only members of a paradigm but not extend to derivationally

- related forms. The change in early Greek *hen* 'one/NOM.SG.NTR' / *hem-os* 'one/GEN.SG.NTR' to *hen/hen-os*, for example, did not affect the derived feminine form *hm-ía*.
- 10 Thus we explicitly claim that language users are not "ideal speaker-listeners," the usual characterization adopted in generative grammar, nor are they "perfect speaker-listeners," the characterization argued for by Lightner (1975: 634–5); see Joseph (1992) for some discussion.
- 11 I say "at least root morphemes" here, since some views of morphology, such as the "a-morphous morphology" of Anderson (1992) or any "process morphology" model, treat all non-root morphemes, for example, affixes, vowel gradation, reduplication, etc., as being (part of the) morphological operations by which grammatical categories are realized with respect to roots. Similarly, I say "at least idiosyncratic information" since many views of the lexicon now embed non-general but well-definable generalizations in the lexicon via lexical rules and/or various lexical redundancy rules.
- 12 The standard definition of a morpheme as the smallest meaning-bearing unit of form shows this nexus of form and meaning even though it is not clear that it is a suitable definition; problems are posed by "empty" elements of form like *-al* in *syntactic-al*, by purely classificatory elements of form such as stem vowels in French verbal conjugation (*fin-i-r* 'to finish' versus *recev-oi-r* 'receive'), by non-phonetically determined buffer consonants such as *-n* in the English indefinite article *a/an*, etc.
- 13 Note that *Cold* in this combination does not behave like a regular adjective in that it cannot be inflected; the comparative *colder war* does not have the specialized meaning that the positive degree has (and might be used instead in a more literal sense, as in *The battle in Murmansk in January represented a colder war than the battle of Jakarta*). If one wanted a comparative form of *Cold War*, a periphrasis would be needed, as in *The early twentieth century witnessed more of a Cold War between superpowers than the latter part*.
- 14 Klausenburger (1976) draws attention to developments in which a morphologically based generalization becomes (more) lexicalized, but he calls them "demorphologization"; in the view developed here, such a development would be a subtype of morphologization, that is, greater (morpho)lexicalization, not movement out of the morphology entirely.
- 15 An additional issue beyond what is described here is the recent criticism that grammaticalization is an epiphenomenon, something that describes a result of other changes and not an independent mechanism of change in itself. See Campbell (2001b), Janda (2001), Joseph (2001a), Newmeyer (1998, 2001), and Norde (2001) for some discussion.
- 16 McMahon (1994a: 167) gives useful brief definitions for these terms: *attrition* is "the gradual loss of semantic and phonological substance"; *condensation* is "the shrinking of scope, or syntagmatic weight"; *paradigmaticization* is "the integration of syntactic forms into morphological expressions"; *coalescence* is "a gain in bondedness . . . syntactic elements may become morphological"; *obligatorification* is "the loss of paradigmatic variability"; and *fixation* is "a loss of syntagmatic variability."
- 17 This situation is exactly what happened with umlaut in German;

- see Janda (1998a, this volume) for discussion and references.
- 18 Hopper and Traugott (1993: 145–9) discuss the phonological aspects of their “morphologization” (see n. 4 above), and talk about “fusion” of elements as a common concomitant; yet they must admit that “many of the phonological changes that accompany morphologization are not peculiar to this process but are simply part of the same processes of assimilation, attrition, and other kinds of reduction that are found more generally in non-prominent syllables and across junctures” (p. 147). Thus it is not clear why they should contribute to a special place on the grammaticalization cline.
- 19 I thank Hans Henrich Hock for bringing this example to my attention. It can be noted, of course, that with suitably “heavy” noun phrase objects, the word order for both constructions can be the same, for example, *I have written all the letters I was asked to write*; there are prosodic differences in the two constructions that differentiate them even with heavy objects, but the word order in the usual case is distinct as well.
- 20 There is only Lehmann’s characteristic of “fixation” that would be applicable here, but as noted above, a clustering of six characteristics to an equivalent extent is needed in grammaticalization, according to Lehmann.
- 21 It is important to point out that under strict form-based, yet classical, definitions of “morpheme,” involving looking for recurring partial elements in related words, it would be possible to parse *friend* and *fiend* so as to identify *-nd* as a morpheme. Admittedly, such a parsing is not necessarily feasible in all the examples that Hopper presents (the *-n* of *forlorn* is probably not recoverable as a parsable element, for instance), but it is in more than he might be willing to admit. Perhaps what Hopper really means is that the function of the sequence of sounds has changed significantly – *-nd* no longer marks a present participle, the *-i-* of *handiwork* is a formal element only gluing together two morphemes instead of the nominal prefix it once was (cf. Old English *hand-ge-weorc*) – but that view leads to a very different picture of what is going on from that painted by Hopper. He does say (p. 31) that “since there is no categorial point at which a morpheme ceases to be a morpheme and becomes a set of functionally empty phonological segments, there is ultimately no clear dividing line between the phonological and morpholexical levels of language,” a position which seems to define morphemes only in terms of a linking of form and meaning, despite the existence in languages of morphemic elements with no clear meaning (such as *-al* in *syntactical*, as described above). I readily admit that it is often difficult to decide whether two elements are to be connected as a morpheme (as with *-nd*, just discussed), but to go from that uncertainty to a position that there is no categorial difference seems to be an extreme leap.
- 22 See below, n. 40, for some further criticisms of “phonogenesis.”
- 23 Yet their reaction has generally been dismissive, as they have treated the counterexamples as if they do not exist or are somehow inconsequential or beside the point. See Lehmann (1982: 16–19) and Heine (this volume) for such a viewpoint, and Hopper and Traugott (1993: 126–8) for relevant discussion.

- 24 It is only fair to point out that some discussions of grammaticalization do recognize the notion of morphologization, though none seems to be as explicit about it as I try to be here. For example. Hopper and Traugott (1993: 130ff) talk about morphologization but focus just on “‘compacting’ – the fusing of erstwhile independent elements with each other, most especially the development of clitics into inflections,” which is recognized here as only part of what morphologization entails.
- 25 In later work, such as Zwicky (1994a), clitics are argued not to be a distinct type in their own right, but rather to subsume anomalous affixes (“phrasal affixes”) and anomalous words (“bound words”).
- 26 This criterion is essentially the principle of lexical integrity (see Bresnan and Mchombo 1995 for some discussion).
- 27 In particular it usually selects the feminine stem, for instance *douce-ment* (versus masculine *doux*), a remnant of course of the fact that Latin *mente* was a feminine noun, but synchronically for French just an idiosyncrasy of the adverb formation operation.
- 28 The literature is divided on where to locate compounds in the grammar; see Fabb (1998) for some discussion, with references.
- 29 I give pre-Modern forms in transliteration, rather than attempting to approximate the presumed pronunciation in a transcription; Modern forms are cited in an approximately phonemic transcription except where otherwise noted.
- 30 This section draws heavily on Joseph (1999) and especially Joseph and Pappas (2002), where these developments are discussed in considerably greater detail; see also Joseph (1983a, 1990) for discussion of the history of the Modern Greek future.
- 31 There are some modern dialects, such as Cypriot Greek, that retain final *-n*, as well as some forms in the standard language, such as the genitive plural in *-on*, that similarly show *-n#*. It is likely that there have been several waves of the loss of final *-n*, with interim periods in which *-n#* was restored from the learned language and/or analogically reintroduced (e.g., if the loss began as a sandhi phenomenon).
- 32 Indeed, the range of variability in the expression of the future tense in Medieval Greek texts is striking (and there are other formations that do not involve a form of *thélō* that are not mentioned here). The various types described here co-occur in texts, though there is a clear chronology to the emergence of the different forms, as outlined by Bănescu (1915).
- 33 Actually, *hína* in (7) is somewhat anachronistic, since by the time it was introduced into the future tense formation, it was probably already [na], the form which developed from earlier *hína* by an irregular accent shift to *hina* and regular loss of *h-* and unaccented initial vowels (unless *hina* was always unaccented; Méndez Dosuna 2000: 279); the representation of the Greek here is given in more of an approximation of the pronunciation since in this form the future is now approaching Modern Greek.
- 34 Clitic pronouns at this stage were positioned between *thélei* and the main verb, for example, *thélei to gráphō* ‘I will write it,’ and never occurred as a proclitic to *thélei* (**to *thélei gráphō*). See Joseph (1990: 143–5) for examples and discussion.

- 35 This aspect of the development of *θ* led Joseph (2001a) to argue that grammaticalization is best understood as an epiphenomenon, rather than a process or mechanism of change in itself (see n. 15).
- 36 I must note here that both Hopper and Traugott (1993: 164) and Hopper (1994: 32) cite Joseph and Janda (1988) (the authors of course are grateful for the reference) regarding “demorphologization” (a concept discussed there) but attribute a different concept of demorphologization from that intended; they mention the paper in regard to the notion of a morpheme that has “lost its morphological value” (p. 164) on the way to becoming empty phonological segments (“phonogenesis,” on which see above). However, what was meant by Joseph and Janda’s use of the term is movement of some element out of morphology into a syntactic treatment or possibly a phonological one, the latter not necessarily with any loss of function.
- 37 The term “phonologization” has been used for other phenomena as well elsewhere, for example, within Prague School and structuralist phonology for the situation in which a phonetic difference becomes distinctive (i.e., becomes a phonological distinction).
- 38 See Janda (2001) for relevant bibliography, where a large number of cases (some 70 or so!) are referred to, belying any claim that counterexamples to unidirectionality in grammaticalization are rare and thus not of concern to grammaticalization theory (so Heine (this volume)).
- 39 Pintzuk (this volume) refers to a type of syntactic variation governed by “prosodic constraints and information structure [that] frequently involves a simple alternation in constituent order,” characteristics which would seem to apply to the topical dislocation in French discussed here. Although Pintzuk goes on to say that “this type of variation is diachronically stable,” the Canadian French developments suggest otherwise.
- 40 Hopper (1994: 31) articulates the view that “all phonemes were once morphemes” (so also Hopper and Traugott 1993: 128–9, “there is no evidence that grammatical items . . . can be innovated without a prior lexical history”), a position which clearly has implications for reconstruction. It is worth noting therefore that this extreme view is most assuredly wrong: Hopper overlooks the fact that there can be phonologically excrement elements that take on grammatical value, as with the *-(s)t* in non-standard dialectal English adverbs such as *across*, *onset*, and *twicet*, as well as standard *against*, *amidst*, etc. (see Hock 1976: 216 on the source of this *-t*; I am indebted to Rich Janda for this example), as well as analogical creations that have no real prior existence as lexical items yet can have grammatical value (as Joseph 2001a argues regarding the weak third person nominative pronouns in Modern Greek and in Hittite). To their credit, Hopper and Traugott (1993: 127–8) recognize that “such counterexamples should caution us against making uncritical inferences about directions of grammaticalization where historical data is not available.”

Part V

Syntactic Change

This page intentionally left blank

14 Grammatical Approaches to Syntactic Change

DAVID LIGHTFOOT

People use “grammar” to refer to a wide range of objects, and I adopt a biological view: grammars are mental entities which arise in the mind/brain of individual children. These mental grammars show properties which are not determined by the experience that children have. Children are exposed to utterances made in some context and this experience does not suffice to shape all aspects of their mature grammars. Consequently language acquisition is data-driven only in part. Researchers have postulated genotypical principles which are available independently of experience and which therefore do not have to be learned. These principles determine similarities among grammars, recurrent properties which hold of all grammars. Alongside the invariant principles, we also postulate grammatical *parameters*, which children set on the basis of their linguistic experience and which account for grammar variation. So language acquisition proceeds as children set the parameters defined by Universal Grammar (UG), that is, those genotypical principles and parameters which are relevant for the emergence of language in an individual (Chomsky 1986). The parameters of UG are structural and abstract, as we shall see, and that accounts for the “bumpiness” of language variation; even closely related languages generally differ from each other in several ways and not just in terms of one or two superficial phenomena.

We adopt the schema of (1) where (1a) gives general biological terminology and (1b) gives the specific linguistic terminology: children are genetically endowed with UG and they are exposed to some triggering experience (PLD); as a result, a mature grammar emerges and becomes part of their phenotype:

- (1) a. Triggering experience (linguistic genotype → phenotype)
- b. Primary Linguistic Data (Universal Grammar → grammar)

This perspective on language acquisition was revived in the 1950s. Researchers have focused on poverty-of-stimulus problems, ways in which mature grammars have properties which cannot result entirely from childhood experience. Work has also dealt with language variation, parsing, and acquisition, and

now we have fairly rich theories of individual grammars and the UG from which they arise.¹

Turning now to language change, we note that the speech of no two people is identical, so it follows naturally that if one takes manuscripts from two eras, one will be able to identify differences and so point to language “change.” In this sense languages are constantly changing in piecemeal, gradual, chaotic, and relatively minor fashion. However, historians also know that languages sometimes change in a bumpy fashion, several things changing at the same time, and then settle into relative stasis, in a kind of “punctuated equilibrium,” to borrow a term from evolutionary biology. From the perspective adopted here, it is natural to try to interpret cascades of changes in terms of changes in *grammars*, a new setting for some parameter, sometimes having a wide variety of surface effects and perhaps setting off a chain reaction. Such “catastrophic” changes have distinctive features discussed in section 1.² So grammatical approaches to language change have focussed on these large-scale changes, assuming that the clusters of properties tell us about the harmonies which follow from particular parameters. By examining the clusters of simultaneous changes and by taking them to be related by properties of UG, we discover something about the scope and nature of large-scale parameters and about how they are set. Work on language change from this perspective is fused with work on language variation and acquisition.

1 Parameter Resetting

If we aim to gain insight on how parameters are set by considering the conditions under which parameters came to be set differently in the history of some language, then we need to know what to look for in identifying a new parameter setting, as opposed to diachronic shifts which involve no structural change. New parameter settings have some distinctive characteristics, which are quite independent of any particular grammatical model.

First, each new parameter setting is manifested by a cluster of simultaneous surface changes, and this is one element of the catastrophic nature of parameter resetting. For example, the loss of the operation moving verbs to a distinct inflection position in English (see section 2) entailed the predominance of forms like *Kim always reads the Bible* instead of the earlier *Kim reads always the Bible*, and the obsolescence of inversion and negative sentences like *reads Kim the Bible?* and *Kim reads not the Bible*. These apparently unrelated changes took place in parallel, as demonstrated by the statistical studies of Kroch (1989a), which showed the singularity of the change at the grammatical level (and led Kroch to postulate his Constant Rate Effect; see Pintzuk, this volume).

Second, not only are new parameter settings typically manifested by clusters of changes, but they also often set off chain reactions. A clear example from English is the establishment of verb-complement order at D-structure. Lightfoot

(1991) showed that this entailed indirectly the analysis of the infinitival *to* as a transmitter of properties of its governing verb and the introduction of an operation analyzing *speak to*, *spoken to*, etc. as complex verbs. Such chain reactions can be understood through the acquisition process: a child with the new verb-complement setting is forced by the constraints of UG to analyze some expressions differently from the way they were analyzed in earlier generations.

Third, changes involving new parameter settings tend to take place more rapidly than other changes, and they manifest the S-curve of Kroch (1989a). For example, grammaticalization and morphological change, involving the loss of gender markers (Jones 1988), the reduction in verbal desinences, or the loss of the subjunctive mood generally take place over long periods, often several hundred years. In the interim, individual writers and speech communities show variation in the forms they employ. This kind of gradual cumulateness is usually not a hallmark of new structural parameter settings. The old negative patterns associated with the verb raising operation (*Kim reads not the Bible*) were robust and widely attested in the texts until their demise, which was rapid (see section 2). The fast spread of new parameter settings is not surprising if one thinks of it in the context of language acquisition. Once the linguistic environment has shifted in such a way as to trigger a new parameter setting in some children, the very fact that some people have a new parameter setting changes the linguistic environment yet further in the direction of setting the parameter in the new fashion. That is, the first people with the new parameter setting produce different linguistic forms, which in turn are part of the linguistic environment for younger people and so contribute to the spread of the new setting.

Fourth, obsolescence manifests new parameter settings. When structures become obsolete, it is hard to see how to attribute their obsolescence to the ebb and flow of non-grammatical changes in the linguistic environment. A novel form may be introduced for expressive reasons, to focus attention on some part of the utterance by virtue of the novelty of the form, but a form can hardly drop out of the language directly for expressive reasons or because of the influence of another language. On the contrary, obsolescence must be due to a structural domino effect, a by-product of something else which was itself triggered by the kind of positive data generally available to children (for a recent application of this methodology, see Warner 1995: 542).

Fifth, any significant change in meaning is generally a by-product of a new parameter setting, for much the same reason that the obsolescence of a structure must be the indirect consequence of a more abstract change. Lightfoot (1991: ch. 6) discusses changes affecting the thematic roles associated with particular NP positions with verbs like *like*, *repent*, *ail* (the direct object of these verbs could once be an experiencer, while in modern English only the subject may be an experiencer; so people said things along the lines of "apples like me" for the modern *I like apples*). These changes could not arise as idiosyncratic innovations that somehow became fashionable within the speech-community. It is hard to see how the variation in meaning could be attained by children on a non-systematic basis, and even harder to see how the variation could have

been introduced as a set of independent developments, imitating properties of another language or serving some expressive function through their novelty. Rather, such changes must be attributed to some aspect of a person's grammar which was triggered by the usual kind of environmental factors – for the English psych-verbs, the existence of only structural Cases.

Sixth, new parameter settings occur in response to shifts in simple data, cues occurring in unembedded domains only; they are not sensitive to changes or continuities in embedded domains. Embedded domains are as likely as unembedded domains to reflect the usual toing and froing of the chaotic linguistic environment, but they have no effect on parameter setting. This follows from degree-0 learnability, the claim that grammars are learnable, that is, parameters are set on the basis of data from unembedded binding domains (Lightfoot 1991).

2 V-to-I Raising and its Cue

Let us consider one case of a grammatical change, which is partially understood, using it as a case study to show what further work is needed. It will show how the study of a change is intimately connected, under this approach, with work on grammatical theory and on language acquisition. Operations which associate inflectional features with the appropriate verb appear to be parameterized, and this has been the subject of a vast amount of work covering many languages (see, for example, the collection of papers in Lightfoot and Hornstein 1994). We can learn about the shape of the parameter(s) by considering how the relevant grammars could be attained, and that in turn is illuminated by how some grammars have changed.

Assuming work by Emonds (1978) and Pollock (1989), I adopt the basic clause structure of (2):

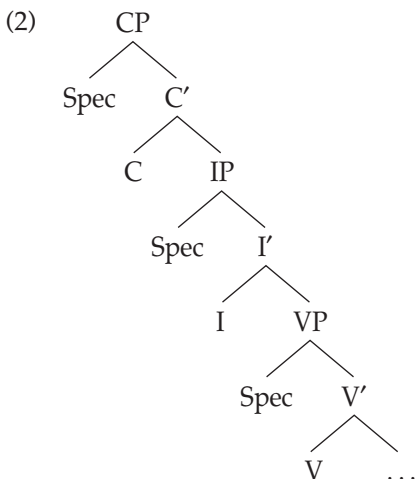

Subjects occur in Spec-IP and *wh*-elements typically occur in Spec-CP. Heads raise from one head position to another, so verbs may raise to I and then further to C. In fact, many grammars raise their verbs to the position containing the inflectional elements ((3c) and (3d)), but English grammars, unusually, have an operation which lowers I on to an adjacent verb ((3a) but not (3b)). We know this because English finite verbs do not occur in some initial C-like position (4a) and cannot be separated from their complements by intervening material (4b):

- (3) a. Jill_{VP}[leave+past]
 b. Jill_I[leave_i+past]_{VP}[e_i]
 c. Jeanne_I[lit_i]_{VP}[toujours e_i les journaux]
 d. lit_i_{IP}[elle e_i VP[toujours e_i les journaux]]
- (4) a. *visited you Utrecht last week?
 b. *the women visited not/all/frequently Utrecht last week

What is it that forces French children to have the V-to-I operation and what forces English children to lack the operation and to lower their Is?

It is reasonable to construe the English lowering operation as a morphological phenomenon: in general, lowering operations are unusual in the syntax, and a syntactic lowering operation here would leave behind a trace which would not be bound or properly governed. Furthermore, one would expect a morphological operation but not a syntactic operation to be subject to a condition of adjacency. Therefore the representation in (3a), reflecting a morphological operation, contains no trace of the lowered I. In any case, the English lowering needs to be taken as the default setting, as argued in Lightfoot (1993), Lasnik (1999), and Roberts (1999); there is no non-negative evidence available to the child which would force her or him to select an I-lowering analysis over a V-raising analysis (3b) for English, if both operations could be syntactic and subject to an adjacency requirement: children would need to know that (4a) and (4b) do not occur (negative data, therefore unavailable as input to children). In that case, let us take the morphological I-lowering analysis as the default setting.

Now one can ask what triggers the availability of a syntactic V-to-I raising operation in grammars where it may apply. Some generalizations have emerged over the last several years. One is that languages with rich inflection may have V-to-I operations in their grammars, and rich inflection could be part of the trigger (Rohrbacher 1994). However, the presence of V-to-I raising cannot be linked with rich inflection in a simple one-to-one fashion. It may be the case that if a language has rich inflection, then V-to-I raising is available (Lightfoot 1991; Roberts 1997). If there is no rich inflection, a grammar may have the raising operation (Swedish – see Lightfoot 1997) or may lack it (English). Indeed, English verb morphology was simplified radically and that simplification was complete by 1400; however, V-to-I movement disappeared only in the seventeenth century, so there was a long period when English grammars

had very little verbal inflection but did have V-to-I movement. In that case, there needs to be a *syntactic* trigger for V-to-I movement. So, for example, a finite verb occurring in C, that is to the left of the subject NP (as in a V2 language or in interrogatives), could only get there by raising first to I, and therefore inversion forms like (3d) in French could be syntactic triggers for V-to-I.³

Here we need to spell out an assumption about language acquisition: associated with each parameter defined in UG is a *cue*, some kind of structure. Children scan their linguistic environment for these cues and set the parameters accordingly. This view is, I believe, implicitly assumed in some work on acquisition (notably work by Nina Hyams, e.g., Hyams 1986) but it needs to be spelled out more precisely. It differs from other models (Chomsky 1965; Clark 1992; Clark and Roberts 1993; Gibson and Wexler 1994), which take a child to converge on a grammar if it succeeds in generating the input data to which the child is exposed. The idea that language acquisition is cue-based and does not proceed in this “input-matching” fashion results to some extent from work on abrupt language change, where children arrive at grammars which generate data quite different from grammars of an earlier generation (Lightfoot 1999b).

So triggers consist not of sets of sentences but rather of partially analyzed syntactic structures (Lightfoot 1991: ch. 1): Parameters are set by these partial structures, elements of I-language which act as what Dresher and Kaye (1990) call cues. So a cue-based learner sets a Spec-head parameter (Spec precedes/follows its head) on the basis of exposure to data which *must* be analyzed with a Spec preceding its head, for example, [_{spec}John's] [_N hat]]. This parameter can only be set, of course, when the child has a partial analysis which treats *John's* and *hat* as separate words, the latter a head noun, etc. Less trivially, a cue-based learner acquires a V2 grammar not by evaluating grammars against sets of sentences but on exposure to structures commencing with a XP followed immediately by a finite V, where there is no fixed grammatical or thematic relation between the initial phrasal category and the finite verb, effectively where the initial XP is a non-subject (Lightfoot 1999b). This requires analyzing the XP as in Spec-CP and so _{CP}[XP] is the cue for a V2 system; the cue must be represented robustly in the PLD. As noted, the cue-based approach to parameter setting is *implicitly* assumed in some earlier work; also it corresponds to work on the visual system (which develops as organisms are exposed to very specific visual structures; Hubel 1978; Hubel and Wiesel 1962; Sperry 1968), it has been productive for phonologists concerned with the parameters for stress systems (Dresher and Kaye 1990; Dresher 1999; Fikkert 1994, 1995), it has been invoked for some syntactic problems by Fodor (1998), and it represents something quite different from the input-matching approach of Gibson and Wexler, Clark, and others.

Returning to our case study, under a cue-based learning approach, one would say that the cue for the V-to-I parameter is a finite verb in I, that is, _I[V], an element of I-language. One unambiguous instance of _I[V] is an I containing the trace of a verb which has moved on to C, as in the structure of (3d).

Indeed, I would guess that this would be a very important expression of the cue, and I doubt that structures like (4b) would be robust enough to trigger V-to-I in isolation; this can be tested (see below). Adopting terminology from Clark (1992), one can ask how robustly the cue is “expressed”; it is *expressed* robustly if there are many simple utterances which can be analyzed by the child only as ${}_1[V]$. So, for example, the sentences of (3c) and (3d) can only be analyzed by the French child if the V *lit* raises to I; a simple sentence like *Jeanne lit les journaux* ‘Jeanne reads the newspapers,’ on the other hand, could be analyzed with *lit* raised to I or with the I lowered into the VP in the English style, and therefore it does not express the cue for the V-to-I parameter.

In English the cue for the V-to-I operation, ${}_1[V]$, came to be expressed less in the PLD in the light of three developments in early Modern English. First, the modal auxiliaries (*can, could, may, might, shall, should, will, would, must*), while once instances of verbs that could raise to I, were recategorized such that they came to be base-generated as instances of I; they were no longer verbs, and so sentences with a modal auxiliary ceased to include ${}_1[V]$ and ceased to express the cue for V-to-I movement. The evidence for the recategorization is the obsolescence of (5), which follows if the modal auxiliaries are generated in I and therefore can occur only one per clause (5a), without an aspectual affix (5b), (5c), and mutually exclusively with the infinitival marker *to*, which also occurs in I (5d):

- (5) a. John shall can do it
 b. John has could do it
 c. canning do it
 d. I want to can do it

This change has been discussed extensively in Lightfoot (1979, 1991), Kroch (1989a), Roberts (1985, 1993a), and Warner (1983, 1993), and there is consensus that it was complete by the early sixteenth century.

Second, as periphrastic *do* came to be used in negatives like *John did not leave* and interrogatives like *did John leave?*, so there were still fewer instances of ${}_1[V]$. Periphrastic *do* began to occur in significant numbers at the beginning of the fifteenth century and steadily increased in frequency until it stabilized into its modern usage by the mid-seventeenth century. Ellegård (1953) shows that the sharpest increase came in the period 1475–1550.

Third, in early grammars with the much-discussed verb-second system all matrix clauses had a finite verb in C. Therefore all matrix clauses expressed the cue for V-to-I, ${}_1[V]$ (on the assumption that V could move to C only by moving first to I). As these grammars were lost and as finite verbs ceased to occur regularly in C, so the expression of the cue for V-to-I raising was reduced.

By quantifying the degree to which a cue for a parameter is expressed, we can understand why English grammars lost the V-to-I operation and why they lost it after the modal auxiliaries were reanalyzed as non-verbs, as the periphrastic *do* became increasingly common, and as the V2 system was lost. We

can reconstruct a plausible history for the loss of V-to-I in English. What we are doing here is identifying when a parameter came to be reset and how the available triggering experiences, specifically those expressing the cue, seem to have shifted in critical ways prior to that parameter resetting. We know from acquisition studies that children are sensitive to statistical shifts in input data. For example, Newport et al. (1977) showed that the ability of English-speaking children to use auxiliaries appropriately results from exposure to non-contracted, stressed forms in initial positions in yes-no questions: the greater the exposure to these subject–auxiliary inversion forms, the earlier the use of auxiliaries in medial position. Also Richards (1990) demonstrated a good deal of individual variation in the acquisition of English auxiliaries as a result of exposure to slightly different trigger experiences. The issue is when trigger experiences differ critically, that is, in such a way as to set some parameter differently.

Our conclusion in earlier work was that V-to-I movement was lost in the seventeenth century, much later than suggested by Kroch (1989a), Roberts (1993a), and others. Warner (1997) now argues that the operation may have been lost as late as in the eighteenth century. He offers some statistics from Ellegård (1953) and Tieken-Boon van Ostade (1987). Ellegård shows that interrogative inversion with a non-auxiliary in positive clauses (i.e., *came he to London?* as opposed to *did he come to London?*) occurred 27 percent of the time for 1625–50, 26 percent for 1650–1700. Tieken-Boon van Ostade shows a drop to 13 percent in the eighteenth century. Negative declaratives with a non-auxiliary (*he came not to London* as opposed to *he did not come to London*) occur 68 percent in 1625–50, 54 percent in 1650–1700, dropping sharply to 20 percent in the eighteenth century. The drop is actually sharper than these figures suggest; Tieken-Boon van Ostade's figures for the later period include a high proportion of recurrent items (*know*, *doubt*, etc.) which Ellegård omitted. A particularly interesting feature of these figures is the discrepancy between the interrogatives and the negatives, which lends some support to the hunch (above) that structures like those underlying (3d) are a more effective expression of the cue ${}_1[V]$ than structures like those of (4b). In any case, we see that structures like (4b) were robust and widely attested in the texts of the late seventeenth century and then they disappeared rapidly – the kind of bumpiness that the notion of grammatical parameters leads us to expect.

The historical facts, then, suggest that lack of rich subject–verb agreement cannot be a sufficient condition for absence of V-to-I, but it may be a necessary condition. Under this view the *possibility* of V-to-I not being triggered first arose in the history of English with the loss of rich verbal inflection; similarly in Danish and Swedish. That possibility never arose in Dutch, French, or German, where verbal inflections remained relatively rich. Despite this possibility, V-to-I continued to be triggered and it occurred in grammars well after verbal inflection had been reduced to its present-day level. However, with the reanalysis of the modal auxiliaries, the increasing frequency of periphrastic *do* and the loss of the V2 system, the expression of ${}_1[V]$ in English became less and less robust in the PLD. That is, there was no longer anything very robust in the

PLD which had to be analyzed as ${}_i[V]$, that is, which *required* V-to-I, given that the morphological I-lowering operation was always available. In particular, sentences like (4b) with post-verbal adverbs and quantifiers had to be analyzed with the V in I, but these cues were not robust enough to set the parameter and they disappeared quickly, a by-product of the loss of V-to-I.

This suggests that the expression of the cue dropped below some threshold, leading to the elimination of V-to-I movement. The next task is to quantify this generally, but we should recognize that the gradual reduction in the expression of ${}_i[V]$ is not crucial, but rather the point at which the phase-transition took place, when the last straw was piled on to the camel's back. This can be demonstrated by building a population model, tracking the distribution of the ${}_i[V]$ cues in the PLD, and identifying the point at which the parameter was reset and V-to-I ceased to be triggered (differing, of course, from one individual or one dialect area to another). This work remains to be done (see below), but one hopes to find correlations between the changing distribution of the cue and the parametric shift.

3 Other Case Studies and Some Comparisons

This grammatical approach to diachrony *explains* changes at two levels. First, the set of parameters postulated as part of UG explains the unity of the changes, why superficially unrelated properties cluster in the way that they do. Second, the cues associated with the parameters permit an account of why the change took place, why children at a certain point set a parameter differently: the distribution of those cues changed in such a way that a threshold was crossed and the relevant parameter was set differently. That is as far as this model goes, and it has nothing to say about why the distribution of the cues should change. That may be explained by claims about language contact or socially defined speech fashions but it is not a function of theories of grammar, acquisition, or change – except under one set of circumstances, where the new distribution of cues results from an earlier parametric shift; in that circumstance one has a “chain” of grammatical changes. One can, of course, embed these grammatical accounts in an appropriate model of population change; see section 4.

Notice that this approach to change is independent of any particular grammatical model. Warner (1995) offers a persuasive analysis of parametric shift using a lexicalist HPSG model, quite different from the one assumed here. Interesting diachronic analyses have been offered for a wide range of phenomena, invoking different grammatical claims: Fontana (1993), van Kemenade (1987), Pearce (1990), Roberts (1993a, 1993b, 1994, etc.), Sprouse and Vance (1999), Vance (1995), and many others.

Our general approach to abrupt change, where children acquire very different systems from those of their parents, is echoed in work on creolization under

the view of Bickerton (1984, 1999), and the acquisition of signing systems by children exposed largely to unnatural input (Goldin-Meadow and Mylander 1990; Newport 1999; Supalla 1990). For several years Bickerton has worked on plantation creoles, where new languages appear to be formed in the space of a single generation. He argues, surely correctly, that situations in which “the normal transmission of well-formed language data from one generation to the next is most drastically disrupted” will tell us something about the innate component and how it determines acquisition (Bickerton 1999); it certainly shows that children do not always proceed by converging on grammars which match the input.

The work of Bickerton and his associates is limited by the sketchiness of the available data for the earliest stages of creole languages, but the view that new languages emerge rapidly and fully formed despite very impoverished input receives striking support from work on signed languages. The critical fact here is that only about 10 percent of deaf children in the US are born to deaf parents who can provide early exposure to a conventional sign language. This means that the vast majority of deaf children are exposed initially to fragmentary signed systems which have not been internalized well by their primary models. This is often some form of Manually Coded English (MCE), which maps English into a visual/gestural modality. Goldin-Meadow and Mylander (1990) take these to be artificial systems, and they show how deaf children go beyond their models in such circumstances and “naturalize” the system, altering the code and inventing new forms which are more consistent with what one finds in natural languages. Supalla (1990) casts more light on this, showing that MCE morphology fails to be attained well by children, who fail to use many of the markers that they are exposed to and use other markers quite differently from their models. He focuses on deaf children who are exposed only to MCE with no access to American Sign Language (ASL), and he found that they restructure MCE morphology into a new system. Clearly this cannot be modeled by input-matching learning devices, because the input is not matched. Furthermore, it is not enough to say that MCE morphology simply violates UG constraints, because that would not account for the way in which children devise new forms. More is needed from UG. The unlearnability of the MCE morphology suggests that children are cue-based learners, programmed to scan for clitic-like, unstressed, highly assimilable inflectional markers. That is what they find standardly in spoken languages and in natural signed languages like ASL. If the input fails to provide such markers, then appropriate markers are invented; children seize appropriate kinds of elements which can be interpreted as inflectional markers. The acquisition of signed languages under these circumstances offers an opportunity to understand more about abrupt language change, creolization, and cue-based learning (Lightfoot 1999b).

The characterization of abrupt grammatical change sketched in this chapter makes sense only if one views grammars as individual mental entities, and not as some kind of social entity codifying the data attested in the texts of some period. Failure to make this simple distinction has entailed confusion in

the literature, discussed in Lightfoot (1995). There has been interesting work on the replacement of one grammar by another, that is, the spread of change through a speech community. So, Kroch and his associates (Kroch 1989a; Kroch and Taylor 1997; Pintzuk 1990; Santorini 1992, 1993; Taylor 1990) have argued for coexisting grammars. That work postulates that speakers may operate with more than one grammar in a kind of “internalized diglossia,” and it enriches grammatical analyses by seeking to describe the variability of individual texts and the spread of a grammatical change through a population (see Pintzuk, this volume).

However, the approach sketched here is not consistent with three other pervasive lines of thought. One is the idea that all change is gradual and that abrupt, catastrophic change does not happen (Harris, this volume; Harris and Campbell 1995; Hopper and Traugott 1993; Carden and Stewart 1988). This is sometimes modeled in “lexicalist” theories of grammar, in which particular grammars differ from each other not in terms of settings of abstract parameters but in terms of features on individual lexical items (see Lightfoot 1991: ch. 6 for discussion). This approach to change implies that language acquisition is data-driven, that children match their input, which may vary without limit. Where children appear not to match their input, it is claimed that access to more complete data would reveal that abrupt transitions do not happen. Of course, in dealing with historical texts, one is dealing with performance data which do not match grammars perfectly, least of all single grammars. This means that grammarians must interpret the data and each interpretation must find the most appropriate level of abstraction. For example, Fries (1940) offered statistical data showing that Old English alternated between object–verb and verb–object order freely and that “the order of . . . words . . . has no bearing whatever upon the grammatical relationships involved” (p. 199). He found that object–verb order occurred 53 percent of the time around the year 1000 and that it was “gradually” replaced by verb–object order, reducing to 2 percent by the year 1500. However, his counts ignored the distinction between matrix and embedded clauses and he had no analysis of verb-second effects. If one makes such distinctions, one can show that Old English grammars most typically had object–verb order underlyingly and an operation of verb movement raising finite verbs to C in matrix clauses to yield verb-second order (van Kemenade 1987). Kroch and Taylor (1997) show that there was a dialect difference involving movement of finite verbs to C, and consequently the *grammatical* change consisted in a change in the head order parameter and the loss of “verb-second” grammars, each of which was catastrophic (Lightfoot 1999b).

A second incompatible line of thought is that there exists a theory of change with some content (Harris, this volume). If one has a theory of grammar and a theory of acquisition, it is quite unclear what a theory of change is supposed to be a theory of. Presumably a “theory of grammaticalization” (Heine, Traugott, and others, this volume) is a subpart of such a theory of change, insofar as it involves a claim that there is more grammaticalization over time.

A third approach with which I would take issue is the tendency to incorporate historicist elements into UG. Keyser and O'Neil (1985: 3) propose a condition that "whenever possible the language acquisition device reduces the level of optionality, either by change of status or rule loss"; their evidence comes from changes which they analyze as the loss of optional rules. Similarly, Bauer (1995) construes Latin as a thoroughgoing left-branching (LB) language which changes into a thoroughgoing right-branching language (French). She explains this on the grounds that LB languages (with non-agglutinating morphology) were hard to acquire: "Latin must have been a difficult language to master, and one understands why this type of language represents a temporary stage in linguistic development" (p. 188). So she explains her change not in a mysterious theory of history, but rather in terms of human biology: our brains work in such a way that complex structures in LB languages without agglutinative morphology are hard to acquire. This, of course, immediately raises the question of why early Latin would have been LB: "If left-branching structures are . . . acquired with greater difficulty, it is indeed legitimate to wonder why languages, in an early period, exhibit this kind of structure" (p. 216). She concludes that this "still remains to be explained" (p. 217); see Lightfoot (1996a) for further discussion. In the same vein, Kiparsky (1997) appeals to "endogenous optimization" and Roberts (1993b) builds a weighting into UG so that UG effectively encourages learners to "grammaticalize" independently of what they experience through their PLD; this is said to promote Diachronic Reanalyses (see Lightfoot 1997). Historical linguists often see general directions to change and they explain this either by invoking laws of history (i.e., a "theory of change"; see Lightfoot 1979) or by attributing historical effects to genetic predispositions. So Keyser and O'Neil (1985) build a clause into UG predisposing us against optional rules. But for optional rules to be lost, they must first be introduced; if we are predisposed not to attain optional rules, one wonders how they would be triggered in the first place. The identical point holds of the inbuilt tendencies to branch to the right, to "optimize," and to grammaticalize. Rather, one needs a more contingent approach: two people attain different grammars only if exposed to PLD which differ in some relevant way, and therefore parameter resetting is to be explained *only* by a prior change in the PLD. Language acquisition takes place by an interaction of UG, the PLD, and nothing else.

4 Conclusion

For several years syntacticians and some phonologists have claimed that language acquisition proceeds as children set the parameters prescribed by UG. However, there has been little discussion of the general nature of parameters, their number, and how they are set by children. Indeed, some linguists have come to equate parameters with superficial "differences" between languages, trivializing the notion. Parameters have become more fine-grained,

each one capturing smaller ranges of phenomena. So the “pro-drop parameter” fragmented as linguists analyzed languages/dialects showing some but not all of the early diagnostic pro-drop properties; and, most recently, it has disappeared as a distinct parameter altogether (Chomsky 1995: ch. 4). Baker (1996) argues that this fragmentation results from research strategies focusing too narrowly on closely related languages/dialects in so-called “micro-comparative” syntax. This runs the risk of allowing parameters to proliferate and run out of control. We can counter the trend to fragment parameters and equate them with mere surface differences between languages. We can do this by focusing on large-scale shifts in language histories and seeking to determine what smaller shifts in the PLD, specifically in the cues, took place just prior to those large-scale shifts. In this way we gain a better sense of the nature of some central parameters and of what sets them. Our central concern is with the theory of grammars.

Work from this perspective yields a series of case studies as outlined in section 2. We aspire to offer all the ingredients of an explanation of the grammatical change. Our work fuses research on language acquisition, change, and variation. We aim to refine ideas about parameters by considering how they are triggered, combining acquisitional and historical data with learnability concerns. This enables us to characterize the “bumpiness” of language variation and change, and, in doing so, we employ no distinct “theory of change.”

In addition, Niyogi and Berwick (1995) have recently offered a population genetics computer model for describing the spread of new grammars. It is generally agreed that certain changes progress in an S-curve but now Niyogi and Berwick provide a model of the emergent, global population behavior which *derives* the S-curve. They postulate a learning theory and a population of child learners, a small number of whom fail to converge on pre-existing grammars, and they produce a plausible model of population changes for the loss of null subjects in French. The fact that changes can be shown to progress through populations in an S-curve is not surprising to those who have written about chaotic systems and catastrophic changes (Lightfoot 1991: ch. 7), but the success of Niyogi and Berwick is to show that it is not impossibly difficult to compute (or simulate) grammatical dynamical systems; they show explicitly how to transform parameterized theories and memoryless learning algorithms to dynamical systems, producing results along the way.

As we produce productive models for historical change along these lines, relating changes in simple cues to large-scale parametric shifts, our results have consequences for the way in which we think about parameters and how they are set and, therefore, for the way in which we study language acquisition. Experimental work on language learners cannot presently approach the distinction between cue-based learners and those following Clark’s genetic algorithms, or associations between cues and parameter settings. However, with the development of various computerized corpora, Niyogi and Berwick’s results, and an explicit cue-based theory of acquisition, we have all the ingredients for success in the historical domain, as I have sketched it, and we shall

learn something about how acquisition takes place, whether the child is a degree-0, cue-based learner or some other kind of learner.

NOTES

This paper was revised into its present form in 1998.

- 1 For an introductory account emphasizing poverty-of-stimulus problems, see Lightfoot (1982). Chomsky (1986) offers a more detailed account, including some technical material. And Chomsky (1995) represents the presently most advanced version of this research tradition.
- 2 Catastrophe theory, developed originally by the French mathematician René Thom, is an attempt to provide a mathematical framework for modeling various kinds of discontinuous processes. For example, one can lower the temperature of a body of water and

a catastrophic change takes place at 32°F, when it turns to ice; the water does not gradually become more ice-like, but the phase transition is sudden. For a good and balanced discussion of work on catastrophes, see Casti (1994: ch. 2), who points out that the French *catastrophe* is not quite as catastrophic as the English *catastrophe* (p. 53). For us the “catastrophes” are the bumpy discrepancies that one finds from time to time between the input that a given child is exposed to and the output that that child’s mature grammar yields.

- 3 See also Faarlund (1990) and Vance (1995) for illuminating discussion bearing on these matters.

15 Variationist Approaches to Syntactic Change

SUSAN PINTZUK

The development of modern syntactic frameworks and the growth of research in the field of comparative syntax have enabled the rigorous investigation of syntactic change. In one sense, diachronic syntax can be regarded as a form of comparative syntax, where the comparison is between two different stages of the same language rather than between two different cotemporaneous languages or dialects. In the terminology of the Principles and Parameters framework (Chomsky and Lasnik 1993), the difference between two stages of a language can be regarded as a difference in the values of one or more parameter settings; and the goal of the diachronic syntactician is to explain how and why parameter settings change.¹ I will present evidence in this chapter to support the hypothesis that parameter settings do not change abruptly, but rather that change proceeds via competition between two alternative parameter settings during periods of syntactic variation.

The term “variationist” when describing approaches to syntactic change is best understood as referring to methodology rather than to a specific framework or a general philosophy. When the systematic syntactic variation exhibited by languages during periods of change is analyzed quantitatively, generalizations emerge which enable us to describe the time course of syntactic change, and therefore to begin to understand and explain how change starts and how it progresses. The most important of these generalizations are the following three, which will be discussed and illustrated in the remainder of this chapter. It should be emphasized that these generalizations are not untested hypotheses, but rather empirical results supported by the analysis of historical data.

First, a distinction must be made between two types of syntactic variation. The first type is controlled by prosodic constraints and information structure, and frequently involves a simple alternation in constituent order. This type of variation is diachronically stable, and it does not necessarily lead to or play a direct role in syntactic change.^{2,3} It is commonly found both in modern languages and in the written records of languages no longer spoken; examples include object shift in the Modern Scandinavian languages (Bobaljik and

Thráinsson 1998; Diesing 1996; Jonas 1996), heavy constituent shift in Old English (Colman 1988; Pintzuk 1998a, 1998b; Pintzuk and Kroch 1989), and postposition in Early Yiddish and Ancient Greek (Santorini 1993 and Taylor 1994, respectively). The second type of syntactic variation involves the use by individual speakers of two distinct grammatical options in areas of grammar that do not ordinarily permit optionality. This type is diachronically unstable, with the new option competing with the old one and gradually replacing it.⁴ This type of variation has been labeled the double base hypothesis in regard to variation in underlying (base) structure (Santorini 1992), and more generally grammatical competition (Kroch 1995). It has been found to be characteristic of almost all syntactic changes that have been qualitatively and quantitatively studied in detail. See section 2 for further discussion, and section 3 for an example of grammatical competition in Old English.

The second generalization is that syntactic change is gradual, and may continue for several hundred years or more. This observation is of course not new. But when syntactic variation is analyzed as grammatical competition, our picture of the time course and the nature of syntactic change must be revised. Consider the change from object–verb (OV) word order to verb–object (VO) word order in the history of English. Many studies of Old English syntax (e.g., van Kemenade 1987; Koopman 1990; Lightfoot 1991) claim that Old English was uniformly OV in underlying structure, and that variation in surface word order was a result of optional movement rules which derived VO order from OV structure: leftward movement of the finite verb (verb second) and rightward movement of the object from pre-verbal to post-verbal position (postposition). It is suggested that speakers used these movement rules with increasing frequency over the course of the Old English period, with the result that VO surface word order reached near categorical status by the beginning of the Middle English period. Children from that point on acquired a VO grammar, because the surface word order of the language to which they were exposed was almost entirely VO. According to this view, the underlying grammar during the Old English period was stable, although there was variation in surface word order; the grammatical change occurred abruptly at the beginning of the Middle English period. This picture of the change from OV to VO is challenged in Pintzuk (1996b, 1998a, 1998b), where it is demonstrated that VO underlying structure was a grammatical option in Old English, and competed with OV structure during the Old English period and most of the Middle English period.⁵ When syntactic variation and change is understood in this way, we can see that the new grammatical option (in this case VO structure) does not simply replace the old one (OV structure) at the end of a long period of variation; rather the new option is acquired and both options are used, with the old option finally lost at the end of the period of competition. The gradual nature of syntactic change is thus simply a reflex of the gradual nature of grammatical competition.

The third generalization is that during a period of change, when two linguistic options are in competition, the frequency of use of the two options may differ across contexts, but the rate of change for each context is the same. While some

contexts may favor the innovating option and show a higher overall rate of use, the increase in use over time will be the same in all contexts. This generalization was first proposed by Kroch (1989a) and called the **Constant Rate Hypothesis, and is now known as the Constant Rate Effect due to its overall applicability,**⁶ It will be discussed in more detail in section 1.

When the syntactic variation found in historical texts is analyzed using quantitative methods based on those originally developed for sociolinguistic research, we typically find “orderly heterogeneity” (Weinreich et al. 1968): the variation is systematic and the patterns are revealing. When the distributions of forms are analyzed in detail, either during a single historical stage of a language or over a longer period of time, the results can provide support for the choice of one grammatical analysis over the other (Pintzuk 1999; Taylor 1994), permit the tracking of syntactic variation and change over time (Kroch 1989a; Pintzuk 1996a, 1999; Santorini 1993), uncover dialect differences (Haerberli 2000; Kroch and Taylor 2000), and lead to insights into the nature and organization of the grammar (Kroch 1989a; Pintzuk 1998b). The quantitative methods used to analyze the variation range from the simple examination and comparison of distribution frequencies to the statistically more complex variable rule analysis (see **Cedergren and Sankoff 1974;** Guy, this volume; Sankoff 1988; among many others). Some of these methods will be illustrated in section 3.

Although the variationist approach to syntactic change is not by necessity tied to any particular grammatical framework, most researchers who use the methodology are generative syntacticians who are in accord with the assumptions of the grammatical approach to syntactic change (see Lightfoot, this volume, and the references cited there): they assume a rich, highly structured Universal Grammar, consisting of invariant principles that hold of the grammars of all languages and parameters that are set by triggers in the language learner’s linguistic environment. And they share the view that language change and language acquisition are intimately connected, and that there can be no separate theory of language change. Much of the research discussed in this chapter was carried out in a Principles and Parameters framework, but this is not, of course, a requirement of the variationist approach to diachronic syntax. The changes that are investigated involve phenomena that distinguish modern languages from each other (e.g., the order of verbs and their complements, the behavior of clitics, the verb-second constraint) and therefore can be expressed in any syntactic framework, including Principles and Parameters, Minimalism, Head-Driven Phrase Structure Grammar, Lexical Functional Grammar, and Construction Grammar.

1 The Time Course of Linguistic Change

Suppose that, within a group of historical texts with a range of dates of composition, we can identify one particular linguistic change that we want to study, in which a new form alternates with and eventually replaces an older form in

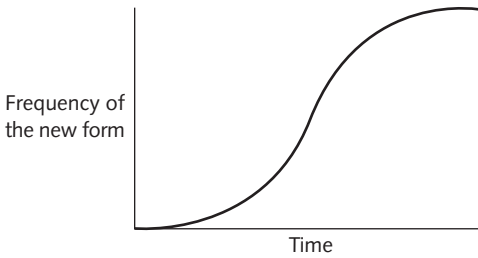

Figure 15.1 S-shaped curve of linguistic change

a variety of linguistic contexts. For each text, we can count the number of times each of the two forms appears in each context. We can then plot the frequency of the new form⁷ against the dates of the texts and examine the time course of the change. Many investigators (Altmann et al. 1983; Bailey 1973; Kroch 1989a; Osgood and Sebeok 1954; Weinreich et al. 1968; among others) have suggested that this type of change – the gradual replacement of one form by another in the language of speakers over time, perhaps over the course of many generations – follows an S-shaped curve, as shown in figure 15.1. The replacement of old forms by new ones occurs slowly at the beginning of the period of change, then accelerates in the middle stage, and finally, at the end of the period, when the old form is rare, tails off until the change reaches completion.

Both Altmann et al. (1983) and Kroch (1989a) propose that a specific mathematical function, the logistic, underlies the S-shaped curve which represents the usage of speakers over time. The importance of selecting a specific function is that statistical techniques can be used to fit a particular set of data to the function and estimate its parameters, as will be described in detail below. When parameters for different datasets are estimated in this way, they can be compared, and the results of the comparisons can be used to draw conclusions about the change under investigation.

The equation of the logistic curve is given in (1) below. In this equation, p is the frequency of the new form, and varies between 0 and 1, that is, between 0 percent and 100 percent. t is a variable representing time, and s and k are constants – that is, they are parameters that are fixed (perhaps differently) for each particular instance of an S-shaped curve:

$$(1) \quad p = \frac{e^{k+st}}{1 + e^{k+st}}$$

An equivalent form of equation (1) is shown in (2). The left-hand side of (2) is called the logistic transform of the frequency, or logit:

$$(2) \quad \ln \frac{p}{1-p} = k + st$$

While the logistic of equation (1) is an S-shaped curve, the logit of equation (2) is a straight line, a linear function of time.⁸ s is the slope of the line; k is the y-intercept, and is related to the frequency of the new form at some fixed point

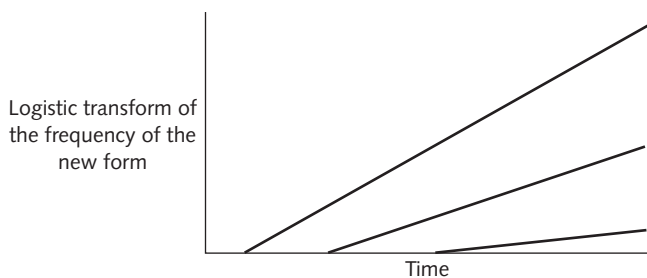

Figure 15.2 Bailey's model of linguistic change

in time, $t = 0$. Of course, as Kroch and others have pointed out, the logistic model is an idealization of linguistic change, because there is no time t for which the frequency p of the new form equals either 0 or 1 in these equations. In other words, the model can only approximate the process of change at both the beginning, called the point of actuation, where the frequency of the new form jumps from 0 to some small positive value, and at the end, when the old form dies out and the frequency of the new form jumps from some high value to 1.

Let us now consider how changes begin and how they spread. A concrete example to keep in mind is the use of auxiliary *do* in Middle and Early Modern English (Ellegård 1953; Kroch 1989a; Warner 1998), within three different syntactic contexts: negative declarative clauses, affirmative declarative clauses, and affirmative questions. In principle, change may be actuated in one of several different ways. Speakers may start to use the new form simultaneously in all contexts, either at the same initial frequency or at different initial frequencies; this is simultaneous actuation. For example, auxiliary *do* may appear for the first time in all three types of clauses in several texts composed during the same decade, with the same initial low frequency in all clause types. Or speakers may start to use the new form sequentially, first in the most favoring context and only subsequently in less favoring contexts; this is sequential actuation. Again, the initial frequencies may be either the same or different. Once actuation has occurred, the change may in principle spread in two different ways: either at different rates in different contexts, or at the same rate in each context. For example, speakers' use of auxiliary *do* may increase in frequency more rapidly in negative clauses than in affirmative declarative clauses and questions. Bailey (1973), for example, claimed that actuation occurs sequentially, with change spreading more quickly in the most favoring context, less quickly in the less favoring contexts. This model is illustrated in figure 15.2, where the three straight lines represent three plottings of the logit over time, one for each of three different linguistic contexts. Notice that these three lines all have different slopes and different y-intercepts (the s and k parameters in equations (1) and (2)), as is clear from the fact that they rise at different rates and will intercept the y-axis at different points.

In contrast to Bailey, Kroch (1989a) proposed the Constant Rate Effect (CRE): while the frequency of use of competing linguistic forms may differ across

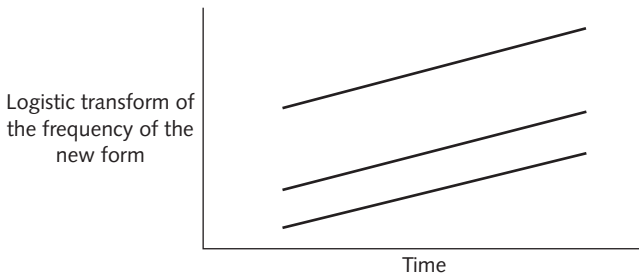

Figure 15.3 Kroch's model of linguistic change

contexts at each point in time during the course of the change, the rate of change for each context is the same. Kroch's model is illustrated above in figure 15.3. Notice that these three lines have different y-intercepts (the k parameter), but they all have the same slope (the s parameter); in other words, they are parallel.

It should be pointed out that the word "constant" in the Constant Rate Effect does not refer to a constant rate of increase in p , the frequency of the new form. As stated above, and as can be seen from the S-shaped curve in figure 15.1, which plots the frequency p of the new form over time, the frequency increases slowly at first, then the rate of increase accelerates, and then it finally tails off. What is "constant" in the Constant Rate Effect is that the change is the same across linguistic contexts, so that the frequency of the new form changes in the same way in all contexts. In terms of equations (1) and (2), the parameter k may be different for each context, but the parameter s is constant for all contexts, as shown by the identical slopes of the straight lines in figure 15.3. As Kroch (1989a: 199) states, "Contexts change together because they are merely surface manifestations of a single underlying change in grammar. Differences in frequency of use of a new form across contexts reflect functional and stylistic factors, which are constant across time and independent of grammar."

Kroch (1989a) presents four cases of linguistic change that have been studied quantitatively – the replacement of *have* by *have got* in British English from 1750 to 1934 (Noble 1985), the rise of the definite article in Portuguese possessive noun phrases from the fifteenth through the twentieth century (Oliveira e Silva 1982), the loss of verb second in Middle French (Fontaine 1985; Priestley 1955), and the rise of auxiliary *do* in English between 1400 and 1700 (Ellegård 1953) – and shows that all four provide strong support for the CRE. Additional research has demonstrated that the CRE holds for the replacement of I-final structure by I-medial structure in the history of English and Yiddish (Pintzuk 1996a and Santorini 1993, respectively) and the change from OV to VO in the history of Greek (Taylor 1994).

Notice that the grammatical analysis which underlies both the change and the quantitative patterns may be quite abstract. For example, Kroch (1989a)

builds on and extends the work of Adams (1987a, 1987b) for Middle French to show that three very different surface changes – the loss of subject–verb inversion, the loss of null subjects, and the rise of left dislocation structures – can all be analyzed as reflexes of the same underlying grammatical change, the loss of the verb second constraint. These three surface phenomena are the three different contexts in which variation between options is exhibited. The CRE predicts that all three surface alternations will proceed at the same rate during the period from 1400 to 1700, as indeed Kroch (1989a) demonstrates. Similarly, Taylor (1994) shows that in three periods of Classical Greek, the distribution of clitics and weak pronouns produces the same measure of verb-medial versus verb-final clause structure as an independent estimate of that ratio derived from the distribution of NP and PP complements and the rates of postposition.

Conversely, in other cases of syntactic variation and change, identical surface forms may be derived by different grammatical processes in different contexts. In these cases the CRE is irrelevant, since it holds only for contexts in which the surface forms are reflexes of the same underlying grammatical alternation. In fact, it is generally true for these cases that change will proceed at different rates in the different contexts, since it is unlikely that two separate and unrelated grammatical alternations will advance at the same rate. For example, Hirschbühler and Labelle (1994) show that the change from *ne* infinitival-verb *pas* to *ne pas* infinitival-verb in the history of French affected lexical verbs, modals, and auxiliaries at different times, and that it proceeded at different rates for the three verb types. These findings thus seem to present a counterexample to the CRE. However, Hirschbühler and Labelle use structural evidence to demonstrate that what appears to be a single grammatical change in three different contexts actually represents two separate changes: a change in the position of *pas*, and a loss of verb movement to T. It is only to be expected that these unrelated changes should proceed at different rates, precisely because they are unrelated.

As was stated above, the CRE has been demonstrated to hold of particular syntactic changes in the history of five languages: English, French, Greek, Portuguese, and Yiddish. It would, of course, be desirable to test more cases of syntactic change so that the overall validity of the CRE can be conclusively demonstrated. This is not, however, an easy task: quantitative diachronic syntactic research requires the use of large historical corpora, containing well-documented data which represent a broad range of genres, dialects, authors, and dates of composition.⁹ Corpora of this type are not readily available for all languages, although their construction and use for linguistic research is becoming more common.¹⁰ Quantitative work of the type described in this chapter is greatly facilitated by the use of corpora such as the Penn–Helsinki Parsed Corpus of Middle English, the Brooklyn–Geneva–Amsterdam–Helsinki Parsed Corpus of Old English, and the York Corpus of Old English Poetry; these corpora are syntactically annotated for efficient data retrieval of syntactic constructions and constituent orders.

2 Grammatical Competition

It was stated above that during periods of syntactic change, the variation that we see in the language of historical texts reflects grammatical competition; in other words, the variation is between two distinct grammatical options in areas of grammar that do not ordinarily permit optionality. The way in which the competing options are analyzed and described depends upon the syntactic framework being used. In a Principles and Parameters framework, options generally correspond to contradictory parameter settings: for example, head-initial versus head-final structure, verb second versus non-verb second. In contrast, competing options within a Minimalism framework correspond to the strength of features on functional heads, strong versus weak. Thus it is not two entire grammars that are in competition, but rather two contradictory options within a grammar.

As a concrete example, consider the order of verbs and their objects. If we look at modern languages, verb–object order is fixed except in certain well-defined contexts. Thus Modern German normally has object–verb order, as shown in the (a) examples below, while Modern English has verb–object order, as shown in the (b) examples:

- (3) a. Die Kinder haben *den Film gesehen*.
 b. *The children have *the film seen*.
- (4) a. *Die Kinder haben *gesehen den Film*.
 b. The children have *seen the film*.

It is of course possible to find examples of verb–object order in German, but these can be shown to be derived by independent syntactic processes, like verb second in clauses with finite main verbs, as shown in (5). Similarly, we can find sentences with the object preceding the verb in English; for example, clauses derived by topicalization or *wh*-movement, as shown in (6) and (7):

- (5) Die Kinder *sahen den Film*.
 The children saw the film.
- (6) *That* I never *knew* before.
- (7) *What books* have you *read* lately?

Thus modern languages can be described in terms of the order of constituents within the verb phrase: English and the Scandinavian languages are head-initial, with the verb (the head of the verb phrase) preceding its complements and adjuncts; German and Dutch are head-final, with the verb following its complements and adjuncts. So clear is the difference between the two types of

languages that it has been frequently proposed as a parameter of Universal Grammar.¹¹

In contrast, Old English shows much more variation in the order of verbs and their complements than modern languages: in almost any context, complements can appear either before or after the verb, as illustrated in (8) and (9) below. The variation is not simply between dialects of Old English or even between speakers: all extant Old English texts, including those known to be the work of a single author, exhibit the variation (see “Abbreviations” below for full details of sources):

(8) he ne mæg *his agene aberan*
 he not may *his own support*
 “He may not support his own.” (CP 52.2)

(9) þu hafast *gecoren þone wer*
 you have *chosen the man*
 “You have chosen the man.” (ApT 23.1)

Moreover, Old English exhibits variability that cannot be analyzed in terms of independent syntactic processes, such as leftward verb movement or rightward movement of complements and adjuncts. In particular, light elements like pronominal objects and particles do not move rightward in West Germanic languages;¹² but in Old English they may appear either before or after the non-finite main verb, as shown in (10) and (11). Pintzuk (1996b, 1998a, 1998b) uses these clauses as evidence for grammatical competition in Old English, head-final versus head-initial VPs, and shows that there is additional quantitative and distributional evidence for such an analysis:

(10) & woldon hig *utdragan*
 and (they) would them *out-drag*
 “and they would drag them out.” (ChronE 215.6 (1083))

(11) he wolde adræfan *ut anne æþeling*
 he would drive *out a prince*
 “he would drive out a prince” (ChronB (T) 82.18–19 (755))

Evidence for grammatical competition has been found in a large variety of languages in the process of syntactic change. Early Yiddish and Old English exhibited variation between I-final structure and I-medial structure during the period of change from the former to the latter (Santorini 1989, 1992, 1993; Pintzuk 1993, 1996a, 1999). Ancient Greek changed from OV to VO between the Homeric period and the New Testament and, like Old and Middle English, varied between the two structures during the long transition period (Taylor 1990, 1994). The verb-second constraint was lost in Late Middle English, and during that period the language exhibited variation between verb-second and

SVO structure (Kroch 1989b). Early Spanish was variably verb second, and clitics varied in their behavior between heads and full projections (Fontana 1993). And Middle French, like Middle English and early Spanish, was variably verb second (Adams 1987a, 1987b; Dupuis 1989; Vance 1995). Similar optionality has not been found in modern standard languages, which show uniform head-initial or head-final structure, categorical verb second or lack thereof, and non-varying clitic behavior. This is not to claim that modern grammars are different in nature from the grammars of older languages, but rather that in the older texts we see evidence for the use of competing grammatical options which has not been attested for modern standard languages.¹³

Despite the strong evidence for the existence of grammatical competition, the concept is not an uncontroversial one. Three theoretical objections are discussed and answered in Santorini (1992: 619–21):

Objections to the double base hypothesis [i.e., grammatical competition] appear to be rooted in three methodological concerns: (1) that it is incompatible with rigorous structural analysis, (2) that it illegitimately complicates the analysis of linguistic phenomena, and (3) that it contradicts the spirit of generative inquiry. None of these objections can be maintained, however. (1) In the case at hand, it is precisely the reliance on statements of distribution of the sort that are standardly used in the literature as diagnostics of syntactic structure that leads us to entertain the double base hypothesis. (2) In linguistics, as in any other domain of empirical inquiry, what is illegitimate is to assume that the relationship between particular phenomena and the theoretical principles governing them is necessarily simple . . . [J]oint considerations of empirical adequacy and theoretical consistency may lead us to propose analyses of complex linguistic phenomena in terms of the interaction of more than one grammatical system . . . (3) That linguistic variation might arise from the interaction of more than one grammatical system is expected given the distinction between E(xternalized)-language and I(nternalized)-language that is at the heart of the generative paradigm . . . The changing patterns of linguistic variation that we observe in the historical data . . . are phenomena of E-language. From a perspective that focuses on I-language, we study these patterns in order to deduce the principles of I-language governing them. Conversely, when respect for established generalizations concerning I-language . . . yields empirically adequate, theoretically simple analyses of pre-theoretically complex phenomena . . . then these phenomena themselves can be taken to provide empirical support for the theoretical distinction between E-language and I-language.

And Kroch (1995: 184–5) responds to an objection concerning grammar competition and learnability:

It is sometimes said that admitting grammar competition into the theory of language will introduce learnability problems; but this objection is based on a misunderstanding. . . . Since the learner will postulate competing grammars only when languages give evidence of the simultaneous use of incompatible forms, s/he will always have positive and unequivocal evidence of competition. In the

absence of such evidence, the learner will simply analyze the language unambiguously in accord with the evidence. The difficulty introduced by the possibility of grammar competition is not for the learner but for the linguist, for whom a methodological question arises; namely, how to know when grammar competition should be invoked and when failure to find a unified analysis means only that more research is needed.

3 The Position of the Finite Verb in Old English: A Case Study

In this section I demonstrate the methodology used in analyzing syntactic variation and change by examining the position of the finite verb in Old English.¹⁴ As shown in the examples below, the verb can appear in almost any position in both main and subordinate clauses. In (12), the finite verb is in second position; it is in final position in (13), and in third or fourth position in (14):¹⁵

- (12) a. eow *sceolon* deor abitan
 you *shall* beasts devour
 "beasts shall devour you" (ÆLS 24.35)
- b. þæt se eorðlica man *sceolde* geþeon
 so-that the earthly man *should* prosper
 "so that the earthly man should prosper" (ÆCHom i.12.26)
- (13) a. him þær se gionga cyning þæs oferfæreldes forwiernan *mehte*
 him there the young king the crossing prevent *could*
 "the young king could prevent him from crossing there" (Or 44.19–20)
- b. þa apollonius afaren *wæs*
 when Apollonius gone *was*
 "when Apollonius had gone" (ApT 5.12)
- (14) a. Wilfrid eac swilce of breotan ealonde *wes* onsend
 Wilfred also from Britain land *was* sent
 "Wilfred was also sent from Britain" (Chad 162.27–164.28)
- b. swa swa scep from wulfum & wildeorum *beoð* fornumene
 just-as sheep by wolves and beasts *are* destroyed
 "just as sheep are destroyed by wolves and beasts" (Bede 46.23)

Two different analyses have been proposed for Old English to account for the position of the finite verb. Van Kemenade (1987), among others, claims that Old English is an asymmetric verb-second language much like Modern German and Dutch, with uniform head-final structure and leftward verb movement to C in main clauses only. Constituents positioned after the otherwise

clause-final verb are derived by various types of rightward movement. According to this analysis, main and subordinate clauses with the finite auxiliary verb¹⁶ in second position are derived by two different processes: verb second in (12a), but verb raising in (12b);¹⁷ the derivations are sketched in (15) and (16). I will call this analysis the asymmetric analysis:

(15) Verb second in main clauses:

[_{CP} [eow]_j [_C sceolon_i] [_{IP} deor t_j abitan t_i]]

(16) Verb raising in subordinate clauses:

[_{CP} [_C þæt] [_{IP} se eorðlica man t_i sceolde geþeon_i]]

In support of the asymmetric analysis, there is evidence for the use of verb raising in Old English: namely, clauses with two or more constituents before the verb cluster, as shown in (14) above. Under the assumption of head-final structure, these clauses cannot be derived in any other way. I will demonstrate below, however, that the frequency of verb raising in Old English is comparatively low.

Pintzuk (1993, 1996a, 1999) proposes a different analysis for the position of finite verbs in Old English: grammatical competition between head-initial and head-final structure within the IP, with obligatory movement of the finite verb to I in both main and subordinate clauses. According to this analysis, main and subordinate clauses with the finite auxiliary in second position are derived by the same process, leftward verb movement to I, as shown in (17) and (18). I will call this analysis the symmetric analysis:

(17) Verb movement to I in main clauses:

[_{IP} [eow]_j [_I sceolon_i] [_{VP} deor t_j abitan t_i]]

(18) Verb movement to I in subordinate clauses:

[_{CP} [_C þæt] [_{IP} [se eorðlica man]_j [_I sceolde_i] [_{VP} t_j geþeon t_i]]]

Notice that in support of the symmetric analysis, there is evidence for leftward verb movement in Old English subordinate clauses. This evidence is distributional in nature, and involves the position of “light” constituents like particles, pronouns, and sentential adverbs in subordinate clauses with finite main verbs. Light elements may appear either before or after the verb, as shown in (19), but they appear post-verbally only in clauses like (19b), with the verb in second position. The distribution is shown in table 15.1.

(19) a. Pre-verbal particle:

þæt he his stefne *up* ahof
that he his voice *up* lifted

“that he lifted up his voice” (Bede 154.28)

Table 15.1 Position of light elements (particles, pronouns, and monosyllabic adverbs) in Old English subordinate clauses with finite main verbs

Position of the finite verb	Post-verbal light elements	Pre-verbal light elements	Total
Second	43 = 16.7%	214 = 83.3%	257
Third or later	1 = 0.3 %	315 = 99.7%	316

b. Post-verbal particle:

þæt he ahof upp þa earcan
 so-that he lifted up the chest
 "so that he lifted up the chest" (GD(C) 42.6–7)

The conclusion that must be drawn from table 15.1 is that light elements do not freely move rightward, probably because of a heaviness constraint on postposition. They appear post-verbally only in clauses where the verb has moved leftward to I, as shown in (20). The distribution in table 15.1 demonstrates that there is a functional head between CP and VP to which finite verbs may move, and thus that not all subordinate clauses with the finite auxiliary in second position are derived by verb raising:

(20) [_{CP} þæt [_{IP} [he]_i [_I ahof_i] [_{VP} t_j upp þa earcan t_i]

How then can we choose between the two analyses for subordinate clauses with the finite verb in second position, since there is evidence in the Old English texts for each of the structures proposed? I will now show that quantitative analysis of the data provides two types of evidence that supports the symmetric analysis over the asymmetric analysis: first, the comparatively low frequency of verb raising; and second, the increase in the frequency of finite verbs in second position at the same rate over time in main and subordinate clauses.

Consider first the frequency of verb raising. We have seen above that there is evidence for a process of verb raising in Old English because of examples like (14a) and (14b), repeated below as (21). But verb raising must be optional in Old English, since there are many clauses with the non-finite main verb followed by the finite auxiliary, as in (22). To estimate the frequency of verb raising in Old English subordinate clauses, we can compare the number of clauses like (21), with two or more constituents before the finite + non-finite verb cluster, to the number of clauses like (22), with two or more constituents before the non-finite + finite verb cluster. The frequency of verb raising estimated in this way is about 12 percent (see table 15.2):

Table 15.2 Frequency of verb raising and potential verb raising in Old English subordinate clauses

Number of constituents preceding the verb cluster	Order of finite and non-finite verbs			Total	
	Finite + non-finite = (potential) verb raising		Non-finite + finite = no verb raising		
2 or more	11	11.8%	82	88.2%	93
At most 1	217	28.4%	547	71.6%	764

(21) Evidence for verb raising:

swa swa scep from wulfum & wildeorum t_i beoð fornumene;
 just-as sheep by wolves and beasts are destroyed
 “just as sheep are destroyed by wolves and beasts” (Bede 46.23)

(22) Evidence that verb raising is optional:

þe se ealdormon wiþ hiene gedon hæfde
 that the alderman against him done had
 “that the alderman had done against him” (Or 33.13–14)

Now consider clauses like (23) and (24) below. We have shown that in principle, (23) could be derived either from head-final structure by verb raising, or from head-initial structure by leftward movement of the finite verb to clause-medial I; see the structures in (16) and (18) above. (24), in contrast, is clearly a head-final clause, because of the order of the non-finite and finite verbs. We can once again compare the number of clauses like (23), with one constituent before the finite+ non-finite verb cluster, to the number of clauses like (24), with one constituent before the non-finite + finite verb cluster. If all potential instances of verb raising like (23) are indeed true instances of verb raising, then this frequency should be similar to that calculated for clauses like (21) and (22):

(23) þæt se eorðlica man sceolde geþeon
 so-that the earthly man should prosper
 “so that the earthly man should prosper” (ÆCHom i.12.26)

(24) hwæt se bisceop don wolde
 what the bishop do would
 “what the bishop would do” (ÆLS 31.500)

The results of these calculations are shown in table 15.2. It is clear that clauses with one constituent before the verb cluster have a much higher frequency

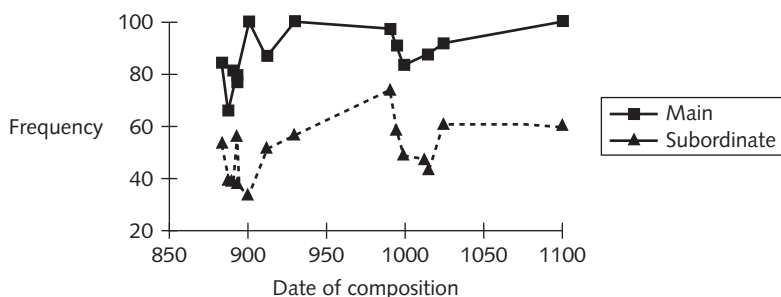

Figure 15.4 The frequency of verb-second order in Old English clauses with auxiliary verbs, 884–1100

Table 15.3 s and k parameters of the frequency of verb-second order in Old English main and subordinate clauses, 884–1100

Clause type	s parameter	k parameter
Main	.519	.14
Subordinate	.525	.03

of finite verbs in second position than the estimated frequency of verb raising would predict. This higher frequency leads us to conclude that the majority of clauses that are in principle structurally ambiguous are actually derived in the same way as verb-second main clauses, that is, by leftward verb movement to clause-medial I. Thus detailed analysis of the variation in the position of the finite verb provides support in favor of the symmetric analysis over the asymmetric analysis.

Now let us consider the second type of quantitative evidence for the symmetric analysis. During the Old English period, the frequency of finite verbs in second position gradually increased in both main and subordinate clauses. As discussed in section 1, we can count the number of times verb-second order appears in each clause type for each text, and then plot the frequency of verb-second order against the dates of the texts and examine the time course of the change. The results are shown in figure 15.4.

When the data for main clauses and subordinate clauses are separately fitted to S-shaped curves, the s and k parameters¹⁸ are estimated as shown in table 15.3.

We can see from table 15.3 that the s parameters for the two curves are almost identical.¹⁹ In other words, the frequency of verb-second order is increasing at the same rate in main clauses as in subordinate clauses. This result strongly supports the symmetric analysis, with the finite verb in second position derived by the same process in main and subordinate clauses: that analysis, plus the

Constant Rate Effect, predicts that the rate of change will be the same in both clause types. On the other hand, if the position of the finite verb were derived by two unrelated processes in main and subordinate clauses, as in the asymmetric analysis, then the result shown in table 15.3 would be entirely unexpected.

I have demonstrated in this section how detailed quantitative examination of the variation exhibited by historical texts can provide support for the choice of one grammatical analysis over another: although either a symmetric or an asymmetric analysis of the position of the finite verb is possible on the basis of the structural evidence, the quantitative facts support the symmetric analysis.

4 Conclusions

Evidence has been presented above that careful and rigorous analysis of syntactic variation is crucial for an understanding of syntactic change. The variationist approach described in this chapter combines the insights of formal syntactic analysis with quantitative methodology and the tools of corpus linguistics, to arrive at a new perspective on syntactic change. Change takes place via grammatical competition between distinct options that correspond to obligatory choices in modern standard languages, and change progresses at the same rate in all contexts in which the alternation occurs.

Still, there are four important issues that remain to be addressed in this chapter: the actuation of new grammatical options, the instability of grammatical alternates, the relationship between historical written texts and spoken language, and the relationship between usage data and grammar. First, the question of actuation: how are new grammatical options introduced? Some cases of syntactic innovation and change have been explained in terms of language-internal processes, such as the reanalysis of syntactic or discourse structures (see, among many others, Auger 1994; Givón 1977). Other cases have been described as syntactic borrowing through language contact (see Campbell 1987). Kroch and Taylor (1997) and Kroch et al. (2000), in ongoing research into syntactic differences between northern and southern Middle English dialects, also suggest language contact, not in the form of borrowing but rather because of imperfect second language acquisition by adults.²⁰ They trace the source of the asymmetric verb-second dialect of northern Middle English to the Northumbrian dialect of Old English, and hypothesize that the Viking invaders who settled in the north imperfectly acquired verbal agreement inflection; the collapse of verbal morphology forced a reanalysis of the verb second construction, with verb movement to I (symmetric verb-second) reanalyzed as verb movement to C (asymmetric verb-second). They demonstrate that the only extant Old English texts written in Northumbria during the relevant period of time, the Lindisfarne and Rushworth glosses of the Latin Vulgate Bible, provide evidence for both the loss of verbal agreement and verb movement to C. Although this hypothesis about the source of syntactic

innovation seems promising, it is clear that it provides an explanation for only some cases, leaving others unaccounted for. Icelandic, for example, was relatively isolated for much of its history, yet it changed from OV to VO (Hróarsdóttir 1996, 2000; Rögnvaldsson 1996).

The second issue is the diachronic instability of grammatical variants in competition: once actuation occurs, why doesn't the variation simply remain stable? In other words, why does the frequency of the new variant increase and eventually replace the old one? Kroch (1995) links syntactic variation to variation in features on functional heads; in other words, to the existence of syntactic doublets in the lexicon during periods of syntactic change. He suggests that in syntax, as in morphology, doublets that are semantically and functionally non-distinct are disallowed; and that doublets of this type, which may arise through language contact (see the discussion above), compete in usage until one of the forms wins out. Sociolinguistic, psycholinguistic, and stylistic factors may have an effect on the favoring of one variant over the other, as may the tendency toward cross-categorical harmony in the directionality of heads, which Hawkins (1990) suggests is due to parsing constraints; see also Kiparsky (1996a) for discussion.

The third issue is the relationship between historical written texts and spoken language. Change originates in the spoken language, and historical linguists generally assume without comment that changes enter the written language in approximately the same order as they appear in speech, after some undetermined time lag. The assumption, therefore, is that the written language reflects the spoken language of some earlier time. This is not necessarily the case; future research comparing written and spoken modern languages may help to determine the chronology of linguistic change.

And finally, how do usage data and the texts themselves relate to grammar, the internal system of principles and parameters? The quantitative studies cited in this chapter use mainly distributional and statistical evidence, but draw conclusions about the characteristics of the grammars used to generate the historical texts. At present there exists no widely accepted theory relating grammatical options and grammar use. But we have seen that evidence for grammatical competition and support for the Constant Rate Effect can be found in the history of many different languages. The orderliness of the variation found in the data, and the close fit between statistical patterns of usage and formal syntactic analysis, strongly suggest that a coherent theory relating grammar and usage can and should be formulated.

ABBREVIATIONS

ÆCHom *The Homilies of Ælfric: A Supplementary Collection . . .*, ed. John Collins Pope. London and Oxford: Oxford University Press, 1967–8. (Early English Text Society, 259–60.) [Cited by homily and line number.]

- ÆLS *Ælfric's Lives of Saints . . .*, ed. Walter William Skeat. London and Oxford: Oxford University Press, 1881–1900, reprinted 1965/6 (in two vols). (Early English Text Society, 76, 82, 94, 114.) [Cited by homily and line number.]
- ApT *The Old English Apollonius of Tyre*, ed. Peter Goolden. Oxford: Oxford University Press, 1958. (Oxford English Monographs, 6.)
- Bede *The Old English Version of Bede's Ecclesiastical History of the English People*, ed. Thomas Miller. London: Early English Text Society, 1890–8.
- Chad *The Life of St Chad: An Old English Homily*, ed. R. Vlees Kruyer. Amsterdam: North-Holland.
- ChronB *Two of the [Anglo-]Saxon Chronicles Parallel, with Supplementary Extracts from the Others*, eds John Earle and Charles Plummer. Oxford: Clarendon Press, 1892–9, Version B.
- ChronE *Two of the [Anglo-]Saxon Chronicles Parallel, with Supplementary Extracts from the Others*, eds John Earle and Charles Plummer. Oxford: Clarendon Press, 1892–9, Version E.
- CP *King Alfred's West-Saxon Version of Gregory's Pastoral Care*, ed. Henry Sweet. London: N. Trübner, 1871–2. (Early English Text Society, 45, 50.)
- GD(C) *Bischof Woerferths von Worcester Übersetzung der Dialoge Gregors des Grossen*, ed. Hans Hecht. Leipzig: n.p., 1900–7. (Bibliothek der angelsächsischen Prosa, 5.) Repr. in Darmstadt: Wissenschaftliche Buchgesellschaft, 1965. [Cited by page and line number.]
- Or (1) *King Alfred's Orosius*, ed. Henry Sweet. (Early English Text Society, 79, 1883.) (2) *The Old English Orosius*, ed. Janet Bately. (Early English Text Society, 2nd ser., 6, 1980.)

ACKNOWLEDGMENT

I would like to thank Tony Kroch for helpful discussion, Richard Janda and Brian Joseph for detailed comments on an earlier version of this chapter, and George Tsoulas and Anthony Warner for comments and related discussion. All omissions and errors remain my own responsibility.

NOTES

- 1 See Lightfoot, this volume, for a discussion of the role of parameter setting in syntactic change.
- 2 Prosody and information structure may serve to distinguish contexts for change, but their effect is orthogonal to the syntactic change in progress; see Kroch (1989a) and Pintzuk (1998b, 1999).
- 3 The distinction between two types of syntactic variation and the fact that only one type plays a role in change means that syntactic change differs from phonological change in this respect; see Guy, this volume.
- 4 The use of the two options may be influenced by sociolinguistic,

- psycholinguistic, or stylistic factors.
- 5 Roberts (1997) and van der Wurff (1997) present analyses of Old English and Middle English, respectively, with OV order derived by optional leftward movement from VO structure; see Pintzuk (1998b) for arguments against uniform VO structure throughout the history of English.
 - 6 As Guy, this volume, points out, the stability of constraint effects across dialects and languages and particularly across time suggests that the Constant Rate Effect holds not only for syntactic changes but also for at least some instances of phonological change.
 - 7 In other words, the ratio of the number of new forms over the sum of the number of old forms + new forms.
 - 8 Equations (1) and (2) are equivalent: (2) can be derived from (1) by applying a series of mathematical operations to both sides of the equation. The advantage of working with equation (2) is that straight lines are easier to compare visually than S-shaped curves. Of course, the real comparison is done quite precisely by comparing the values of parameters k and s of the two curves.
 - 9 Determining the dates of composition of historical texts is not always a simple matter. See Pintzuk (1999) for discussion.
 - 10 Researchers in the history of English are particularly fortunate in having available the Toronto Dictionary of Old English Corpus, which contains all of the approximately 2000 extant Old English texts; and the Helsinki Corpus, a compilation of samples from Old, Middle, and Early Modern English texts; as well as other English historical corpora.
- Large corpora are available for some other languages as well: as just two examples, the ARTFL Project, a computerized database of about 2000 French texts from the seventeenth century to the present; and the Icelandic sagas of the thirteenth and fourteenth centuries (Halldórsson et al. 1985–6; Kristjánisdóttir et al. 1988, 1991).
- 11 Again, depending upon the syntactic framework, the parameter can be defined in terms of the directionality of case or theta-role assignment, or the strength of features forcing overt movement. What is important here as elsewhere is not the precise definition of the difference but the fact that languages do differ in this respect.
 - 12 See Koster (1975) for an early use of the position of particles as a diagnostic for underlying order in Dutch.
 - 13 Modern dialects sometimes characterized as “non-standard” may exhibit variation which the standard languages do not; for some of these cases, the variation may be the residue of syntactic change that has not yet gone to completion.
 - 14 The verbal syntax of Old English is complex, and the analyses sketched here are greatly simplified. For discussion and debate on the position of the finite verb in Old English, see Hulk and van Kemenade (1997); van Kemenade (1987, 1997); Kroch and Taylor (1997); Pintzuk (1993, 1996a, 1996b, 1999). For detailed presentations of the quantitative analysis and a description of the database and how it was constructed, see Pintzuk (1996a, 1999). Additional general works on Old English syntax include Denison (1993); Mitchell (1985); Traugott (1972, 1992); Visser (1963–73).

- 15 Complementizers and subordinating conjunctions are not counted for the position of the finite verb.
- 16 The term “auxiliary verb” is used for expository convenience to refer to all verbs that take infinitival or participial complements.
- 17 Verb raising and verb projection raising are processes which permute the order of finite verbs and non-finite verbs in verb-final clauses; see, among others, den Besten and Edmondson (1983); Haegeman and van Riemsdijk (1986). The term “verb raising” as used here should not be confused with verb movement to I.
- 18 Recall that s and k are parameters of the logistic function (see (1) above), and here represent the slope and intercept of the logistic transform of the frequency of verb-second order. It should be noted that the quantitative analysis summarized here was multivariate, not univariate, with date of composition, type of clause, type of auxiliary verb, gapped constituent in *wh*-clauses, and parallelism in conjoined clauses as the independent variables.
- 19 In fact, if we look at figure 15.4, the two graphs are strikingly similar, despite the fact that the date of composition is not the only independent variable influencing the use of verb-second word order.
- 20 See also Weerman (1993) for the effect of imperfect second language acquisition on the change from OV to VO in the history of English.

16 Cross-Linguistic Perspectives on Syntactic Change

ALICE C. HARRIS

In this chapter I seek to characterize briefly an approach to universals of diachronic syntax that depends crucially upon a rich cross-linguistic corpus.¹ I do this by stating some of the aims of the study (section 1), briefly describing differences between the approach taken here and others (section 2), and describing the method followed (section 3). Section 4 sets out an example from Georgian, which helps with the characterization of reanalysis and actualization (section 5). Section 6 is devoted to an extended example, which illustrates the application of this method in one area of syntax, the change from biclausal to monoclausal structure.

1 Goals of the Study of Syntactic Change

Different approaches to language can be distinguished in part in terms of their goals. Among my goals in studying syntactic change are the following:

- i to characterize syntactic change accurately;
- ii to identify and characterize universals of syntactic change;
- iii to explain syntactic change;
- iv to build a theory of change.

Characterizing syntactic change includes a consideration of general questions, such as: Is syntactic change regular? Is it directional? It includes a description of the mechanisms of syntactic change. In addition, a complete characterization comprises a description of the changes that actually occur in natural languages.

HC applies inductive methods in searching for universals of change, seeking the general rule on the basis of specific cases. Examining instances of the “same” change in diverse languages, we can focus on elements of that change that are the same or similar and eliminate from consideration elements that

vary from one language to another. This method is described in greater detail in section 3.

There are many kinds of explanation, and among the most effective is demonstration of a relationship between the familiar and that which is (or was) unfamiliar. It may be that the better way to view goal (iii) is that we seek simply to understand all aspects of syntactic change, and we include here attention to the causes of change.²

It may be too early to state a general theory of change, but it is at least possible in our current state of understanding to distinguish language-particular from universal aspects of syntactic change, to state generalizations about classes of change, and to identify the kinds of syntactic change that are possible in natural language and, at least by implication, the kinds that are not.

2 Approaches to the Characterization and Explanation of Syntactic Change

Logically there are two basic ways to approach the study of change. One approach begins with a theory and examines what that theory tells us about what we should expect to find in language change. The best-known theory-driven approach of this sort is found in Lightfoot (1979, 1991). What have we learned from these studies? The centerpiece of Lightfoot (1979) was the Transparency Principle, “a rather imprecise, intuitive idea about limits on a child’s ability to abduce complex grammars” (Lightfoot 1981: 358), which was proposed to characterize the point at which change takes place. In Lightfoot (1991) we find the notion of “degree- \emptyset learnability,” likewise a hypothesis about the way a child learns language. But the hypothesis of imperfect learning cannot account for all syntactic change, since many diverse languages retain the source construction beside the reanalyzed structure (see Harris and Campbell 1996). And if we are looking for a set of general principles that limit syntactic change or statements of universals of syntactic change, we come away from Lightfoot (1979, 1991) empty-handed. Lightfoot adroitly avoids committing to anything of substance by arguing that there are no constraints on change other than the theory of Universal Grammar. Naturally, Universal Grammar sets upper limits on change, but the doctrine that it adequately characterizes syntactic change would imply, for example, that it is possible for any sanctioned construction to become any other, without limit. Even if there were no limits on syntactic change other than those imposed by Universal Grammar, one could still state valid generalizations. Yet we come away from these studies with no universals, with no constraints, with no hypotheses that can be tested. It is my position that the *theory* of Universal Grammar is as yet incompletely stated, and that studies of universal properties of syntactic change will contribute significantly to developing it further.³

A second approach is data-driven and seeks to develop generalizations based on the corpus of actual changes. Many studies of the diachronic syntax of individual languages or individual families, including my own studies (e.g., 1985, 1991, 1994, 1995), are intended in this spirit as contributions to the general corpus. There is a wealth of data available on attested changes (i.e., changes during the historical period) in some languages of the Indo-European, Semitic, Uralic, Kartvelian, Dravidian, and Sino-Tibetan families, among others. Even some languages outside these families are attested for a long enough period that syntactic change can be carefully tracked; for example, a comparison of Classical Nahuatl with those of the modern Nahuatl dialects known to be its descendants provides attestation of change. Among the problems for the would-be constructor of theories is that it requires knowledge of the language to analyze the texts, to read much of the secondary literature, and to avoid the pitfalls of incomplete understanding of the synchronic systems.

Among data-driven approaches, some limit themselves to particular aspects of change. For example, while we have learned a great deal from recent work in grammaticalization, that approach is primarily centered on features of words and morphemes and on the transition from the former to the latter. For example, in a grammaticalization approach to the case study in section 4 below, emphasis would be on the transition from verb to auxiliary; in contrast, it is my aim to treat the structural change involved, as well as the verb-to-aux transition. Similarly, recent functionalist studies contribute to our understanding of certain types of change, but they provide no general characteristics of change. Finally, several important recent papers have provided valuable studies of the gradual implementation of particular changes in syntax (e.g., Kroch 1989a; Fischer and van der Leek 1987; Naro 1981; Naro and Lemle 1976). What these studies do not identify clearly is the mechanism that gets these processes started and constraints on that mechanism.⁴ In our work, we seek to provide an overall framework in which contributions to various individual aspects of syntactic change can be correlated with others to make sense of diachronic syntax.

3 Cross-Linguistic Perspective

The method of cross-linguistic comparison developed in HC is part of an overall framework for the description and explanation of data from a wide variety of languages, and on this basis we develop a theory of morphosyntactic change. The method begins by comparing the “same” changes in very different languages. Characteristics that are found in language after language are candidates for universals, and from them we develop hypotheses which can then be tested against additional data. We reason that characteristics that do not occur in all instances must be language-specific. This method begins by comparing changes that are as closely matched as possible for input structure,

output structure, and meaning-function. Generalizations are made at this level, and the comparison proceeds to a higher level, where the previous set of changes are compared with other sets which have already been compared internally. Again generalizations are drawn, and, if appropriate, the comparison continues, throwing an ever-wider net.

An example which is elaborated below in section 6 is the simplification of biclausal structures into monoclausal ones. The changes from independent modal verbs to modal auxiliaries in different languages are compared, and conclusions are drawn. At a second level, these results are compared with conclusions based on comparisons of similar changes involving other independent verbs, such as 'have, hold, keep' used in perfects, and 'be' in progressives. At a third level, other transitions from biclausal to monoclausal structure (i.e., not involving creation of auxiliaries) are compared with the results previously obtained.

A second example, not included below, involves the operation of word order change. We found typological approaches limiting, and we look instead at the changes that actually occur. At a first level we compare verbs and auxiliaries that are not adjacent in the input to the change and are adjacent after the change. At a second level we compare with these results other changes from discontinuous to continuous constituency. A further level adds comparison of changes of the relative positions of head and dependent (HC, 195–238).⁵

Cross-linguistic comparison is set within a theory that recognizes only three mechanisms of syntactic change: reanalysis, extension, and borrowing. Other phenomena that might be described by others as mechanisms of change are, in our view, usually a specific instance or type of one of these. *Reanalysis* is a mechanism which changes the underlying structure of a syntactic pattern and which does not involve any modification of its surface manifestation.⁶ We understand *underlying structure* in this sense to include at least (i) constituency, (ii) hierarchical structure, (iii) category labels, and (iv) grammatical relations. *Surface manifestation* includes morphological marking, such as morphological case, agreement, and gender-class. *Extension* is a mechanism which results in changes in the surface manifestation of a pattern and which does not involve immediate or intrinsic modification of underlying structure. *Borrowing* is a mechanism of change in which a replication of the syntactic pattern is incorporated into the borrowing language through the influence of a host pattern found in a contact language.

Other aspects of this theory that are essential for a complete understanding of cross-linguistic comparison are (i) that syntactic change is regular, in the sense that it is rule-governed and not random (HC, 325–30), (ii) that research to date has not shown any kind of syntactic change to be absolutely unidirectional, though many changes are known to proceed usually in one direction (HC, 330–43), and (iii) that reanalysis depends upon the possibility of multiple analysis⁷ (HC, 81–9).

4 An Example: Georgian *unda*

This example from Georgian will be used in sections 5 and 7 to make several points. As will be immediately clear, the change is very similar to one in English.

In the historical period the Georgian modal ‘want’ has become an auxiliary, expressing a range of modalities, including necessity, intention, and obligation.⁸

Old Georgian *hnebavs* ‘wants’ was an independent verb that could have a nominal object or a sentential object expressed in the subjunctive, in the aorist, or in any of several non-finite forms. Examples with the subjunctive are given in (1) and (2):

- (1) ac’ ve m-nebavs rayta momce me lank’nasa zeda
 immediately I-want.it that you.give.it.me me tray on
 tav-i iovane-s-i natl-is mcemel-isa-y⁹ (Mark 6:25 Ad)
 head-NOM John-GEN-NOM light-GEN giver-GEN-NOM
 “I want immediately that you give me the head of John the Baptist on a tray”
- (2) uk’uetu mi-ndes, rayta dges ege čemda moslvadmde (John 21:22 Ad)
 if I-want.it that he.stand he my coming.until
 “If I wished that he stay until I come”

The present tense forms of this verb in Old Georgian included *m-nebavs* ‘I want it,’ *g-nebavs* ‘you want it,’ *h-nebavs* ‘s/he wants it,’ and the imperfect (past) *mi-nda* ‘I wanted it,’ *gi-nda* ‘you wanted it,’ *u-nda* ‘s/he wanted it.’ The imperfect forms came to be used for the present tense by the eleventh or twelfth century, and a new imperfect was created: *mi-ndoda*, *gi-ndoda*, *u-ndoda* (Sarjvelaže 1984: 412–13). Thus, the forms used today for the present tense of ‘want’ are so-called past-presents. The verb ‘want’ was and is one of a number of verbs, traditionally called *inversion verbs*, which govern a syntactic pattern in which the experiencer (here, the one who wants) is in the dative and conditions indirect object agreement, and the stimulus (here, that which is wanted) is in the so-called nominative case and conditions subject agreement. Thus, the *m-*, *g-*, *h-* and the *mi-*, *gi-*, *u-* prefixes isolated in the forms above in general mark indirect object agreement, in this instance agreement with the experiencer.

(1) and (2) illustrate the pattern in (3), which occurred in both Old and Middle Georgian (from the twelfth century):

- (3) [_s *mas_i* *unda* [_s (*rayta*) Verb S_{ij} (DO) (IO) . . .]]¹⁰
 s/he.DAT ‘want’ COMP SUBJUNCTIVE

The form *unda* cited in (3) was imperfect tense in Old Georgian, but later present. (1) and (2) show that in Old Georgian the initial subject of *unda* (the experiencer, *mas* in (3)) did not have to be coindexed (coreferential) with an argument of the verb of the subordinate clause; when the initial subject of the matrix was coindexed with an argument in the subordinate clause, the latter was generally omitted.

The biclausal structure represented in (3) was reanalyzed as the monoclausal pattern in (4):

- (4) [_s *mas unda Verb* (DO) (IO) . . .]
 s/he.DAT 'should' SUBJUNCTIVE

At the same time, the meaning of *unda* changed from 'want' to a range of modalities including epistemic necessity and deontic obligation. In this innovative usage it ceased to be conjugated, but exists in this single form (derived from and identical to the third person experiencer, third person singular stimulus form). The original biclausal construction continues to exist side by side with the new, maintaining its original meaning, its original structure (with an optional complementizer and with the option of a non-coreferential subject in the complement clause), and its original complete paradigmatic variation (with the tense adjustment from imperfect to present described above), as illustrated in part in (5a), (6a), and (7a) below. Thus in the modern language there is an invariant auxiliary *unda* 'should, ought, must' beside a third person lexical verb form *unda* 's/he wants it,' which still alternates paradigmatically with *minda* 'I want it,' *ginda* 'you want it,' and the plural forms.¹¹ The independent verb 'want' is illustrated below in (5a), (6a), and (7a), and the derived auxiliary in (5b), (6b), and (7b):

- (5) a. *mas unda (rom) gaak'etos*
 s/he.DAT s/he.want.it that s/he.do.it.SUBTV
 "S/he wants to do it" OR "S/he wants him/her to do it"
 b. *man unda (*rom) gaak'etos*
 s/he.NAR should
 "S/he should do it," "S/he must do it"
- (6) a. *minda (rom) gavak'eto*
 I.want.it that I.do.it.SUBTV
 "I want to do it"
 b. *unda (*rom) gavak'eto*
 should
 "I should do it," "I must do it"
- (7) a. *mas unda (rom) c'avides*
 s/he.DAT s/he.want.it that s/he.go.SUBTV
 "S/he wants to go" OR "S/he wants him/her to go"

Table 16.1 Two case patterns in the subjunctive

Morphological class	Subject case	Direct object case
1	Narrative	Nominative
2	Nominative	

- b. is unda (*rom) c'avides
 s/he.NOM should
 "S/he should go"

Following reanalysis as a monoclausal structure, other changes in the clausal syntax were also made. In (4), after reanalysis, the initial subject is still expressed in the dative, the case required by the syntax of the old verb 'want' as an inversion verb; later the pattern required by the (main) verb was extended to this construction. In Georgian, case marking of subjects varies according to the morphological category of the (main) verb. The patterns in table 16.1 illustrate those found in (5b), (6b), and (7b).¹² Class 1 generally contains transitive verbs, and class 2 a subset of intransitives.

These patterns are required in simple sentences, as illustrated in (8):

- (8) a. Class 1: nik'o-m gaak'etos
 Niko-NAR s/he.do.it
 "May Niko do it"
 b. Class 2: nik'o c'avides
 Niko.NOM s/he.go
 "May Niko go"

The difference between the case pattern governed by the independent verb 'want,' described above, and those governed by verbs in the subjunctive provides clear evidence that the subject in sentences such as (5b), (6b), and (7b) is governed by the (main) verb. The verb *gaak'eteba* 'do' of (5)–(6) is a class 1 verb, and in the (b) sentences the subject can only be in the narrative case, as indicated in table 16.1. The verb *c'asvla* 'go' in (7) is a class 2 verb and governs the nominative case; in (7b) the subject can only be in the nominative. The structure of the (b) sentences is represented in (9), that of the (a) sentences in (3):

- (9) [_s man/is unda Verb (DO) (IO) . . .]
 s/he.NAR/NOM 'should' SUBJUNCTIVE

The characteristics that distinguish the older (a) construction of (5)–(7) from the innovative (b) construction are summarized below:

Source construction (a):

Sentence structure: biclausal

Meaning of *unda*: 'want'

Morphology of *unda*: one form in a complete paradigm varying according to tense-aspect category, according to person and number of the experiencer, and according to person and number of the stimulus

Government of case of matrix subject: by the verb 'want'¹³

Innovative construction (b):

Sentence structure: monoclausal

Meaning of *unda*: 'must, should, need, ought, etc.'

Morphology of *unda*: invariant

Government of case of matrix subject: by the main verb

5 Reanalysis, Actualization, and Syntactic Doublets

Some scholars have taken the view that smaller, extensional (surface) changes apply in a language until they force speakers to reanalyze a construction, but Timberlake (1977) has argued effectively that this view is not reasonable. He points out that there would be no reason for these surface changes, extensions, to take place unless reanalysis had already occurred. Timberlake (1977) uses the term *actualization* for the smaller changes that accommodate the reanalysis. Reanalysis is, in fact, not visible to us directly, and it is only through meaning change (which is not always present) or through the actualization that follows reanalysis that we can see its effects.

The Georgian change described above provides a good example of why we cannot reasonably suppose that reanalysis follows actualization. One might at first suppose that in Georgian the inversion construction is disappearing, as it did in English,¹⁴ and that this accounts for the replacement of the dative experiencer of (1)–(2) with a subject with case determined by the main verb, as in (5b), (6b), and (7b). However, the inherited inversion construction is used with numerous other affective verbs in Georgian, such as those meaning 'hear, understand,' 'like,' 'love,' and 'hate,' and it shows no signs of disappearing with any of these lexical items. It is also used in a productive desiderative construction, which creates affective forms out of verbs that are not inherently affective, such as *me-mʒereba* 'I want to sing, I feel like singing' (cf. second and third person forms *ge-mʒereba*, *e-mʒereba*), related to *v-mʒeri* 'I am singing.' The same basic sentence structure is used productively in the evidential construction (Harris 1981). Given that the construction with a dative subject is used so widely and so productively in the language, the replacement of the dative experiencer with one in the case determined by the main verb cannot have been part of the disappearance of this pattern. There simply is no *reason* for the

main verb to begin to determine the subject of *unda*, unless that NP is really the subject of the main verb. The reanalysis of the biclausal construction as monoclausal, as on our analysis, provides the motivation: the case of the (former) subject of 'want' begins to be determined by the main verb because it has become the subject of that verb.

But, one might argue, this approach provides a motivation for actualization but removes the motivation for reanalysis. Not so. Reanalyses are not caused by the accumulated affect of (unmotivated) actualizations, but are brought about by at least two other factors. In some instances, such as that discussed by Timberlake (1977), the source structure becomes ambiguous because of phonological changes. In this type of reanalysis, the original structure is typically *replaced* by a new structure *because of* an ambiguity. In the Finnish case discussed by Timberlake, for example, the original accusative singular **-m* and the genitive singular **-n* fell together through phonological change (final *-m > -n*), and the accusative object was reanalyzed as a genitive object. A second frequently noted cause of reanalysis is the provision of stylistic variety or greater expressiveness. When this is the cause of reanalysis, the innovative structure typically does not replace the source structure, but continues to coexist with it. This is true of the Georgian example above, where the innovative modal usage of *unda* continues to exist side by side with the 'want' usage; the innovative usage provides the language with a new expression. As we see below, our German and Aꞑul examples are also innovations of this sort, and indeed changes of this type are relatively common. We have termed reanalyses in which the innovative structure continues to coexist with the old "syntactic doublets" (Harris and Campbell 1996). While there are probably additional causes of reanalyses, these two types can be clearly identified at this time. Thus, reanalyses apply because of ambiguity or a need for variety of expression (or for other reasons), and actualization gradually brings the innovative structure into line with the rest of the grammar.

A further reason for rejecting the view that surface changes lead up to reanalysis is that this would entail that these smaller changes just coincidentally lead in the same direction. While some reanalyses are simple enough that few adjustments need to be made later by extensions, in other examples many extensions are needed to make the innovative structure consistent with the rest of the language.¹⁵ Reanalysis of modals in English is a good example; according to one count, as many as twelve separate surface changes were made in connection with this reanalysis (Lightfoot 1979: 101–13). To claim that even a significant proportion of these applied before reanalysis, coincidentally accommodating the same reanalysis, even though it had not yet applied, would not be reasonable. The fact that a similar reanalysis is found to apply in language after language (illustrated by Georgian in section 4 and Aꞑul in section 6.1), makes such a hypothesis even less tenable. I conclude, therefore that reanalyses apply relatively early, often setting off a series of extensions, which accommodate the new structure to the existing grammar.

6 Simplification of Biclausal Structures

In sections 6.1–6.2 below, I compare with the Georgian modals two additional examples of *clause fusion*, which we define through the two-part definition in (10):

- (10) Clause fusion is a diachronic process in which:
- i a biclausal surface structure becomes a monoclausal surface structure, and
 - ii the verb of the matrix clause becomes an auxiliary, that of the subordinate clause becomes the main (lexical) verb.

In section 6.1 I present a change in Aḡul for direct comparison with Georgian, but for purposes of this presentation I omit similar changes in the modals of English, German, and other languages. In section 6.2 I take the comparison to a higher level, adding a description of an example of fusion that does not involve modals, namely the formation of the German perfect. Again, for reasons of length, I omit explicit comparison with perfects in English, French, Modern Greek, Georgian, etc.

6.1 Aḡul

Aḡul is a member of the Lezgian subgroup of the North East Caucasian language family. This example differs from those given in section 4 and in section 6.2 in that this change is not attested. For this reason, too little detail is known about the change in Aḡul for this language to provide us with major input to our inductive study of the nature of the change studied. It is included here because the close similarity of this change to that documented in section 4, given that the two languages are unrelated¹⁶ and not in contact, helps to establish that this is a common sort of change.¹⁷

The case marking system of Aḡul is typical of Lezgian languages and of other members of the North East Caucasian family. Subjects of ordinary transitive verbs are in the ergative case, as in (11), and subjects of intransitives and direct objects are in the absolutive case, as in (12):

- (11) c^ohuj-i č^hi ut^hunaw¹⁸
 brother-ERG sister.ABSL beat
 “Brother beats sister”

- (12) č^hi k^harq’aj?a
 sister.ABSL work
 “Sister works, is working”

With affective (inversion) verbs, the experiencer is in the dative, and the stimulus in the absolutive:

- (13) c^huj-i-s č^hi raq:unaw
 brother-OBL-DAT sister.ABSL see
 "The brother sees the sister"

The basic word order is SOV, as illustrated here.¹⁹

In Proto-Lezgian a root modal 'want' occurred as a matrix verb, governing an experiencer in the dative case, and occurring with an embedded clause; (14) illustrates this in Aɣul:

- (14) bawas k:andiw c^huj k^haraq'a-na
 mother.DAT want brother.ABSL work-VADV
 "Mother wants brother to work"

Every Lezgian language preserves this basic pattern, though the marking on the embedded verb varies from language to language (see appendix). In Aɣul, in this pattern the verb of the embedded clause is expressed in the non-finite form referred to as a verbal adverb, with the ending *-na*. When the experiencer of the matrix clause is coreferential with an argument of the embedded clause, the latter is not expressed and the verb takes the infinitive form:

- (15) c^huj-i-s k:andiw č^hi ut^ha-s
 brother-OBL-DAT want sister.ABSL beat-INF
 "Brother wants to beat sister"
- (16) c^huj-i-s k:andiw k^haraq'a-s
 brother-OBL-DAT want work-INF
 "Brother wants to work"
- (17) c^huj-i-s k:andiw č^hi raq:la-s
 brother-OBL-DAT want sister.ABSL see-INF
 "Brother wants to see sister"

Note that in (15)–(17), the clauses of (11)–(13), *mutatis mutandis*, are embedded under 'want.' The complex constructions in (14) and in (15)–(17) have the same basic structure, shown in (18):

- (18) [_s S_i k:andiw [_s S_{i,j} (O) Verb]]
 DAT 'want' INF/VADV

In this structure, the matrix S is the dative experiencer of 'want,' and the S of the embedded clause may be a dative experiencer or an ergative or absolutive subject.

The structure in (18) has been reanalyzed as a single clause, illustrated in (19)–(21):

- (19) c^huj-i č^hi ut^hu-na k:andiw
brother-ERG sister.ABSL beat-VADV should
“Brother should beat sister”
- (20) c^huj k^harq’u-na k:andiw
brother.ABSL work-VADV should
“Brother should work”
- (21) c^huj-i-s č^hi raq:u-na k:andiw
brother-OBL-DAT sister.ABSL see-VADV should
“Brother should see sister”

Notice that the meaning of *k:andiw* has also changed to ‘should.’ The monoclausal structure of (19)–(21) can be represented as (22):

- (22) [s S (O) Verb *k:andiw*]
 ERG/ABSL/DAT VADV ‘should’

Observe the differences between the older construction, (18), and the innovative construction, (22): (i) The verb *k:andiw* ‘want’ in (15)–(17) is a matrix verb, while in (19)–(21) the same form has the meaning ‘should’ and the status of an auxiliary. (ii) The word order of the complex examples (15)–(17) is consistent with the basic SOV order of the language, in that each clause adheres to this order. In (19)–(21), too, the order in the clause is SOV Aux; but because we now have a single clause, the order of the individual words is quite different. (iii) The case of the experiencer in (15)–(17) is dative, determined by the verb ‘want’; this is consistent with the case used for experiencers of other affective verbs, such as ‘see’ in (13). In (19–21), on the other hand, the case of the subject, ‘brother,’ is determined by the main verb, as can be seen by comparing (19)–(21) with the simple sentences at the beginning of this section, (11)–(13). Thus, ‘beat’ takes an ergative subject in (19), as in (11); ‘work’ requires an absolutive in (20), as in (12); and ‘see’ governs a dative in (21), as in (13).

There are many similarities between the attested change in the modal in Georgian and the transition undergone by Aγul. Some of these similarities are also shared by the changes undergone by the modals in English and other languages, but others are not shared. Because the data surveyed at this level necessarily omit a number of relevant languages, I draw no conclusions at this stage but go on to a higher level comparison. At this point I describe the origin of the perfect in French (section 6.2) and the detailed actualization of the reanalysis of the *haben*-perfect in German (section 6.3). These two changes can be compared with the origins of the modal auxiliaries in Georgian (section 4)

and Aꝗul (section 6.1) to formulate generalizations about clause simplification in section 6.4.

6.2 French perfect

Latin had a construction making use of a matrix verb *tenēre* ‘hold,’ *habēre* ‘keep, hold,’ or another verb with a similar meaning:

- (23) *ducēs comprehēnsōs tenētis*
 “You hold the leaders under arrest” (i.e., ‘arrested’) (Cicero, “Orationes in Catilinam,” 3,7,16; Hale and Buck 1966: 327)

Specialists analyze this as a biclausal structure, with the verb of the subordinate clause expressed as a past passive participle, here *comprehēnsōs* ‘arrested,’ which forms a constituent with the direct object of the main clause, here *ducēs* ‘leaders.’ This structure is reflected in early French examples such as (24):

- (24) Et [chis empereres] avoit letres seur lui écrites qui
 and this emperor he-has letters on him written which
 “and this emperor has letters written on him, which [say]” (Robert de Clari, p. 86, l. 11, cited by Brunot and Bruneau 1933: 473)

The passage occurs on a statue and describes the letters (words) written on the statue of the emperor. This is likewise analyzed by specialists as a biclausal construction, with the matrix verb *avoir* ‘have,’ and with the verb of the subordinate clause expressed with the past passive participle, *écrites* ‘written.’ The biclausal possessive structure of Latin and early French can be schematized as (25):

- (25) [Subject_i avoir Object_j [Subject_{i,k} Verb Object_j]]
 (possessor) ‘have’ (possessed)
 Verb

This was reanalyzed, yielding the structure schematized in (26):

- (26) [Subject_i avoir Object_j Verb]
 Aux

The reanalysis involved the following changes, among others: (i) The biclausal structure of (25) became monoclausal in (26). (ii) The matrix verb *avoir* ‘have’ is reflected in the auxiliary of the same form in (26). (iii) Not shown in (25)–(26) is the fact that the meaning of the construction has changed from, roughly, ‘one possesses something to which something has been done’ to ‘one has done something.’ An example from Modern French showing these changes is (27):

- (27) J'ai écrit les lettres
 "I have written the letters"

The reanalysis of the possession construction as a perfect has been greatly simplified here; it is described in greater detail in Vincent (1982), in HC (ch. 7), and in other sources cited there. The actualization of this reanalysis has not been included here, and I turn instead to the more complex actualization of the parallel reanalysis in German.

6.3 German perfect

The expression of the perfect with *haben* 'have' or *eigan* 'own,' which eventually developed in other North and West Germanic languages, is not attested in the earliest forms of German; it first appears in ninth-century works (Ebert 1978: 58). Example (28) illustrates several important characteristics of this construction:

- (28) phigboum habe-ta sum giflanzo-t-an in sinemo
 fig.tree.M 3.have-PRET someone plant-PTCPL-ACC.M.SG in self's
 wingarten
 wine.garden
 arborem fici habebat quidam plantatam in vinea sua
 "A certain person had a figtree as a planted [thing] in his vineyard"²⁰
 (Tatian 102, 2, cited in Dieninghoff 1904: 39)

First, note that it was not required that the subject of the matrix clause be coreferential with that of the embedded clause, as illustrated in (28), and as schematized in (29):

- (29) [O_i *haben/eigan* S_j [Verb $S_{j,k}$ O_i . . .]]
 'have'/'own' PTCPL

(In (29) the clause-internal order of (28) is followed, but not all aspects of this are necessarily significant.) Second, because this construction states literally that something is possessed, there must exist a thing possessed, a direct object; in (28) this is *phigboum* 'figtree.' Third, as indicated in (29), the object of the matrix clause and of the participle had to be coreferential; O_i in the participle did not show up on the surface. However, only transitive verbs were originally used with *haben/eigan*. Fourth, the participle is a deverbal adjective, which is stative in character. Because the embedded clause, 'planted . . . in his garden,' modifies the direct object, it agrees with it in case, gender, and number. In truth, agreeing forms were infrequent in even the oldest German (Ebert 1978: 58), but examples such as (28) with agreement reveal the grammatical relations that existed. An additional adjectival characteristic is that the participle could be negated with the prefix *un-* 'un-' as in (30):

- (30) habet un-gelirnet
 3.has un-learned
 “(s/he) has (it) unlearned (i.e., not yet learned)” (Oubouzar 1974: 12)

The possibility of non-coreferential subjects (as in (28)), the requirement of a direct object in each clause, and the adjectival nature of the participle establish that the construction in (29) is biclausal.

The German periphrasis with *haben/eigan* was originally used only with transitives as part of an expression of the perfect. The perfect of intransitives was formed with *wesan* ‘be’ or, under certain circumstances, with *werdan* ‘become’ in early texts (Paul 1949: 334; see Dieninghoff 1904: 8–9 for details). The perfect with intransitives developed somewhat earlier than that with *haben/eigan*, the focus of our attention here, the latter not occurring in the earliest texts.²¹

The reanalysis of the pattern (29) changed its biclausal structure to monoclausal, with *haben/eigan* ‘have, hold, own’ becoming an auxiliary and the participle becoming the expression of the main verb. Another result of the reduction to a single clause was that there was a single subject of the auxiliary and the main verb; no longer was it possible for each to have its own subject, as it was in (29):²²

- (31) [O_i *haben/eigan* S_j Verb]
 ‘have’/‘own’.AUX PTCPL.MAIN.VERB

Reanalysis also involved a change in meaning; while the old participle was static, in the new meaning it was dynamic. The old analysis, (29), included the notion of possession (e.g., ‘I hold it done’), while the derived (31) expresses the perfect (e.g., ‘I have done it’). One of the manifestations of the change from the possession meaning is the appearance of reflexives; since ‘one possesses oneself’ is not a very useful expression, we may assume that this usage was eschewed until after the change in meaning. In Dieninghoff’s (1904: 49) corpus, Notker is the first to have the direct object reflexive, as in (32):

- (32) si habet sih erretet
 she.NOM 3.has self.ACC saved
 “she has saved herself” (Notker I, 64, 11, cited by Dieninghoff 1904: 49)

Thus, by Notker’s time, approximately 1000 CE, the appearance of reflexives shows that in at least some examples the meaning of possession had been replaced by that of the perfect.

The actualization of the reanalysis involved a number of structural changes. According to evidence cited by Dieninghoff (1904: 15–16) and Oubouzar (1974), the transitive perfect with *haben/eigan* ‘have, hold, own’ developed through a number of stages, next tolerating sentential objects or genitive-case objects, then elided objects. Not until Notker’s texts (c.1000) could (31) be used without an object in the matrix clause, as illustrated by (33)–(34):

- (33) Uuir eîgen gesundot
 we own.1.PL sin.PTCPL
 "We have sinned" (Notker, II, 451, 16, cited by Dieninghoff 1904: 55;
 Ebert 1978: 59)
- (34) danne sî gefaren habeti
 then she.F.SG travel.PTCPL have
 "when she had traveled" (Notker I, 827, 24–6, cited by Dieninghoff 1904:
 55)

An additional structural change is the loss of the requirement of the coreferential object previously necessary in the embedded clause (the participle). Hence, in Notker's work the participle may be intransitive, as in (33) and (34).

The participle likewise lost its adjectival character. As mentioned above, the inflection illustrated in (28) was never common, but it now ceased to occur altogether.²³ While past participles continue to be negated as adjectives with the prefix *un-* 'un-', the negation of the perfect is expressed instead with the negative particle, *niht* 'not.' (35) gives an example from the *Nibelungenlied* (early thirteenth century):

- (35) hât . . . niht vernomen
 3.have not heard/understood.PTCPL
 "(s/he) has not heard" (1713, 4, cited by Oubouzar 1974: 25)

The transitive (now also the intransitive) perfect was consolidated by the loss of the defective auxiliary *eigan* 'own' in this function.²⁴

Oubouzar (1974) has investigated details of the changes in aspect, as the innovative analytic perfect was fit into the existing system of tense/aspect/mood. In particular, in the earlier works, the perfect with *haben* (/ *eigan*) was only rarely used with the durative (her *kursiv*) verbs – the modals and the verb *haben* 'have' itself (see also Paul 1949: 334). By early sixteenth-century texts, however, *haben* could be used both in the pattern illustrated in (36), and in that in (37), both with modals:

- (36) er hat gewolt
 he has wanted.PTCPL
 "he has wanted" (Oubouzar 1974: 52)
- (37) hat wolt aufnehmen
 has wanted take.up.INF
 "(s/he) has wanted to take up" (ibid.)

Several examples of perfect forms of the verb *haben* 'have' itself (*hat gehabt* 'has had') are found in the fifteenth century, but they become more numerous in the following century (Oubouzar 1974: 52). By the middle of the sixteenth

century we find new future perfects (*wird getan haben* 'will have done') (Oubouzar 1974: 65). Oubouzar (1974) documents additional changes that incorporate the perfect in *haben* fully into the verbal system of the language.²⁵

Four of the structural changes described above – reduction to one subject, loss of the matrix object, loss of the embedded object, and loss of the adjectival character of the participle – clearly establish that the output construction is monoclausal. I suggest, however, that for quite some time, both analyses were available to speakers. Oubouzar (1974: 12), for example, points out that most of the examples of the *haben/eigan* perfect in Notker's works are open to the original "possession" interpretation, while a few require interpretation as perfects.

Some scholars have argued that the Germans borrowed the perfect from Latin or from the Romance languages (e.g., Meillet 1930: 129). However, Ebert (1978: 59) argues that the similar construction in Latin must have been borrowed from the Germans, inasmuch as a cognate construction is found in Old Icelandic, which could not have been influenced by Latin or by the languages descended from it. Benveniste (1966) argues that the fact that the perfect with *haben/eigan* forms a complex system with the perfect in *wesan* 'be' and in *werdan* 'become' and that at least some parts of this system are found in all Germanic languages show that this could not have been borrowed outright from Latin. For our purposes it is not essential to reach a conclusion on this issue, since both groups of languages underwent similar processes (see, e.g., Vincent 1982 or Brunot and Bruneau 1933 on French). If the construction was borrowed, it was not simply the monoclausal structure, (31), that was borrowed. I assume that if the construction was borrowed, multiple analyses (29) and (31) were borrowed together; the direction of change would presumably follow from this.

6.4 *A universal characterization of clause simplification*

When we compare the changes described in section 4, in section 6.1, section 6.2, and in section 6.3 with others that cannot be described here, we find a regularity that has not been expressed (but see HC, 191–4). When the construction is first reanalyzed and it begins to be used in a new way (here, for the formation of the perfect in German, for modality in Georgian and Aʏul), conservative rules, reflecting the source structure, at first continue to make it appear that the auxiliary determines grammatical characteristics of those constituents that were in the matrix clause of the source construction, while the main verb does so for those that were in its embedded clause. Grammatical characteristics that are at issue include (i) the number of arguments, the argument roles they fill, and the marking they bear, (ii) the triggering of any lexically conditioned obligatory synchronic rules (for example, Inversion), (iii) the ability to undergo optional synchronic syntactic rules (for example,

Antipassive), and (iv) any exceptional behavior (for example, Quirky Case, suppletion). In German, for example, after the perfect usage had begun the following features of the source construction, (29), were at first carried over to the post-reanalysis construction, (31): (i) *haben* 'have' / *eigan* 'own' required its own object; (ii) *haben* 'have' / *eigan* 'own' was used only with transitive main verbs; (iii) participles were adjectival, as shown by negation with *un-* and by occasional examples of adjectival agreement; (iv) *haben* 'have' itself could not have a perfect; (v) reflexives did not occur, etc. Similarly, immediately after reanalysis in Georgian the reflex of the subject of the matrix verb continued to occur in the dative case (as it does even today in the 'want' construction of (5a), (6a), and (7a)).

However, in each instance the monoclausal construction was eventually extended to all aspects of the structure. For German details of this transition were presented above in section 6.3. In Georgian, the case pattern of the main verb, the reflex of the verb of the embedded clause, was extended to the monoclausal structure. (Additional support for the view that after reanalysis the main verb governs the syntax of the clause comes from additional examples cited in HC, ch. 7.)

Our view is that after reanalysis of biclausal structures as monoclausal, although the main verb governs the syntax, the auxiliary at first appears to govern the constituents that were originally in its clause. This paradox follows in part from our definition of reanalysis, which changes abstract structure but not surface structure, as discussed above in section 5. We have stated this generalization informally as the Heir-Apparent Principle:

The Heir-Apparent Principle

When the two clauses are made one by diachronic processes, the main verb governs the syntax of the reflex clause.

Perhaps this view can best be understood by comparing it with phonological change. After the loss of a conditioning sound, the effects of a phonological rule often continue for some time to be realized. For example, in German, *i* or *j* conditioned umlaut in a preceding syllable; thus, beside the singular *gast* 'guest,' Old High German had plural *gast-i*, later *gest-i*. But when the plural suffix became *e*, which was not an umlaut trigger, the umlauted vowel continued for a time to appear: *gest-e* 'guests.' Although the parallelism of the phonological example and the syntactic example is not complete, the former helps us to see that in language change the form is conservative. In the umlaut example, the stem retains its old form, as though the triggering *i* were still there. In the syntactic example, the grammatical characteristics of the source construction are retained for a time, as though the structure were still biclausal. In *gest-e* we can clearly see the absence of the umlaut trigger, but a monoclausal structure resulting from reanalysis can only be inferred from other characteristics. While the main verb actually governs the syntax of the reflex clause, for a time the conservative form retains the characteristics of its former structure.

It is not a coincidence that the conservative characteristics of a simplified biclausal structure are often the very characteristics that have led synchronic syntacticians to posit complex deep structures for simple surface structures. The characteristics are evidence of a conflict between the two (or more) analyses assigned to the structure by speakers, and a contrast of deep and surface structure provides one way of reconciling these competing analyses synchronically. Diachronically they are reconciled by the recognition of different source and reflex structures.

It is not only the changes illustrated above that show the regularity noted in the Heir-Apparent Principle. In fact, this generalization is not limited to clause fusion (defined above in (10)). The same regularity is also found in focus clefts that become monoclausal focus constructions and in biclausal quotation structures that become monoclausal quotative constructions (HC, ch. 7).

7 The Explanatory Value of Cross-Linguistic Comparison

The most obvious value of cross-linguistic comparison of transitions in syntax is that it enables us to identify universals of syntactic change. While we may develop hypotheses about what is universal on the basis of study of a single language, hypotheses formed in this way are often little more than speculation. Hypotheses about the nature of change that have been developed on the basis of careful consideration of several, varying languages can be taken seriously and tested against further data. Data on syntactic changes are plentiful, and thus there is no shortage of material on which to test hypotheses.

In connection with the identification of universals, comparison also enables us to identify with some assurance those aspects of changes that are language-particular. By comparing the same change in very different, unrelated languages we can both isolate a core that is universal, and identify actualizations that are, in some cases, very different; an example of this is the comparison of the development of Georgian modals and that of English modals (HC, 173–82). By comparing the same change in structurally similar languages, we can begin to formulate an idea of the kinds of actualization required by a particular reanalysis under shared circumstances; an example of this sort offered here is the comparison of Georgian and Aḡul.

Morphology often reveals what is going on in syntax. The examination of a change in a language with a relatively rich morphology may provide evidence relative to the same change in a language with fewer overt indications of syntactic relationships. In this way, in some instances, through comparison we can learn more about a change in a single language than might have been possible through the study of that language alone.

As a by-product of comparison, we may note aspects of change that could, in principle, have been observed by examining a single language, but which,

in fact, have been overlooked. Perhaps this is simply due to the linguist recognizing in an unfamiliar language system a regularity that is easily ignored in the familiar. One example of this is the recognition that if the same change (e.g., independent modal verb to modal auxiliary) occurs in many languages without the particular configuration of morphological and syntactic traits that some have found so important in one language, that configuration cannot be a necessary condition to the change (see discussion above in section 5 and in HC, 176–82). Another example is the recognition that in reanalysis, the innovative construction need not displace the source construction (Harris and Campbell 1996), but may result instead in syntactic doublets.

APPENDIX

- | | | |
|------|--|------------|
| (38) | dadi-ji-z c [°] e d-uf-un k:unža-dar
mother-OBL-DAT brother.ABSL come want-not
“Mother does not want brother to come” | Tabassaran |
| (39) | jiʔa-z gada-di-z riš ak ^h una kanzava
mother-DAT boy-OBL-DAT girl.ABSL see want
“Mother wants the boy to see the girl” | Lezgi |
| (40) | jedi-s gade:- ič ^h i-s iXli ik:an-deš
mother-DAT boy-ERG girl-DAT hit want-not
“Mother does not want the boy to hit the girl” | C’axur |
| (41) | didi-s gada riš-aX-di gaGGir hiGar
father-DAT boy.ABSL girl-LOC ₁ -LOC ₂ look.at want
“Father wants the boy to look at the girl” | Rutul |
| (42) | riž-ez gæde-re ug-oX-un irHar jik ^h əʒi
girl-DAT boy-ERG self-LOC ₁ -LOC ₃ look.at want
“The girl wants the boy to look at her” | Budux |
| (43) | däjis gädä-s riš-ik ^h ir k ^h ič’xis ik ^h äži
mother.DAT boy-DAT girl-LOC fear want
“Mother wants the boy to fear the girl” | K’ric’ |
| (44) | biʃu gada riši-X läk’iširi jiq’qomä
father.DAT boy.ABSL girl-LOC ₁ look.at want
“Father wants the boy to look at the girl” | Xinalug |
| (45) | w-ez buwa-mu wirk:us k’anši wi
I-DAT mother-ERG seek want Aux
“I want mother to seek me” | Arči |

- (46) bu-va-q'-sa, xā-in ḡanavar-a besba-ne? Udi
 want₁-2.SG-want₂-PRES dog-ERG wolf-DAT kill-3.SG
 "Do you want the dog to kill the wolf?"

Examples (38)–(45) are from Kibrik (1979–81); the Udi example (46), the only Lezgian language not included in Kibrik (1979–81), is from my own fieldnotes.

ACKNOWLEDGMENT

I am grateful to Lyle Campbell for many discussions of these ideas and for comments on an earlier version of this manuscript. Naturally, remaining errors are my own.

NOTES

- 1 The discussion throughout draws on the approach set out in Harris and Campbell (1995) (henceforth HC). Although this chapter is entirely new, many of the ideas expressed in it are developed in greater detail in HC (1995), and I have made no attempt to distinguish my ideas from our ideas.
- 2 This statement is intended in a general sense. I do not wish to be thought of as a proponent of hermeneutics, since I prefer cause-and-effect explanations where possible.
- 3 More specific critiques of Lightfoot's proposals and of other theory-driven approaches may be found in HC, *passim*.
- 4 Kroch (1989a) is a partial exception to this; he accepts the position of Ellegård that *do*-Support originated as causative *do*. However, little attention is given to how this interacts with the implementation that he documents carefully.
- 5 The order described here is, of course, the order of investigation, not the order of presentation of the results.
- 6 This definition is based on that given in Langacker (1977: 58); we have also been much influenced by the discussion of reanalysis provided in Timberlake (1977).
- 7 It is not at all a coincidence that the multiple analyses recognized by speakers in the process of reanalysis often correspond to different levels of syntactic analysis proposed by synchronic syntacticians. See further section 6.3 below.
- 8 Georgian is a member of the Kartvelian language family. It is attested from the fourth or fifth century CE.
- 9 The following abbreviations are used in glossing examples: ABSL absolutive case, ACC accusative case, DAT dative case, GEN genitive case, NAR narrative case, NOM nominative case, OBL formant of oblique stem; M masculine, F feminine; SG singular, PL plural; COMP complementizer; AUX auxiliary, INF infinitive, PRET preterite, PTCPL participle, SUBTV subjunctive, VADV verbal adverb;

1. first person subject, etc. In the identification of Old Georgian texts, "Ad" indicates the Adiši codex.
- 10 The order most frequently found in the embedded clause of this construction is verb-initial. In (3) and other such formulas, S is subject, O object, DO direct object, IO indirect object, and V verb.
- 11 It is quite common for a source construction to persist beside the innovative structure derived from it by reanalysis. For discussion and examples, see HC, 81–9, 113, 310–12.
- 12 A more detailed description of the inversion pattern in Old Georgian, with examples, may be found in Harris (1985: 273–86) and a description and illustrations of the patterns summarized in table 16.1 in the same source, especially pp. 49–51. For Modern Georgian, the inversion construction is described in Harris (1981: 117–45), and the patterns of table 16.1 in Harris (1981: 40–7).
- 13 As argued in Harris (1981) and (1985), the experiencer is the initial subject in the inversion construction. This is the sense of "subject" intended here.
- 14 Old English had a construction traditionally called the impersonal, similar to the inversion construction of Georgian, where the experiencer occurred in the dative case and the stimulus conditioned subject–verb agreement (see van der Gaaf 1904).
- 15 Actualization may involve more than extensions; sometimes it may include a further reanalysis (HC, 80–1).
- 16 In the Caucasus, in addition to languages of the Indo-European and Turkic families, one finds languages of three indigenous families: North East Caucasian, North West Caucasian, and Kartvelian. Although many attempts have been made to show a genetic relationship among these three, no one has presented evidence that was at all convincing. One recent work, Nikolaev and Starostin (1994), has adduced evidence that does convince some linguists of a genetic relationship between North East and North West Caucasian (but not Kartvelian). Georgian is a member of the Kartvelian family and is unrelated to Aḡul, a North East Caucasian language.
- 17 The change described here is also not likely to have resulted through any sort of indirect contact, since it has not, to my knowledge, occurred in other languages of the area.
- 18 All Aḡul data presented here are from Kibrik (1979–81). I apologize for the violent content of some examples; alternative examples with minimal contrasts are not available.
- 19 The generalization of word order is based on the observation that speakers treat the experiencer as a subject, as in a number of other languages (Harris 1984).
- 20 This is a form of translation that has become traditional for this Old High German construction (see Paul 1949: 334, etc.).
- 21 In Dieninghoff's corpus, the early texts in which *eigan* and *haben* occur only as main verbs are *Isidor*, the *Interlinear-Version der Benediktiner-Regeln*, *Murbacher Hymnen*, *Monsee-Wiener Fragmente*, and the *Weißburger Katechismus* (1904: 38, 59). Zieglschmid (1929: 56) gives a similar list. Together with the evidence adduced below, this suggests that reanalysis occurred in the tenth century, recognizing that it probably occurred at different times in different dialects.

-
- 22 The perfect with *sein* was probably reanalyzed earlier than that with *eigen* and *haben*. This probably accounts for the fact, noted by Maurer (1926: §49), that in any given period a higher percentage of *haben* than of *sein* precedes the lexical verb. The position following the lexical verb is, in German, the position assigned to an auxiliary. The fact that *sein* took over this position ahead of *haben* (both did so gradually) suggests that the former was the first to be reanalyzed.
- 23 Oubouzar (1974: 12) implies that neither inflection on participles nor participial negation with *un-* is found in her corpus after Notker's work, dated to the eleventh century.
- 24 Dieninghoff (1904: 38, 57) notes that *eigan* fails to appear either as an auxiliary or as a main verb in Tatian's and Williram's works.
- 25 A complete study of the *haben/eigan* perfect would include a more careful consideration of the changes in the place of this construction in the tense/aspect/mood system of the language and of its relation to similar constructions, such as Oubouzar (1974) provides. A complete treatment would examine the gradual implementation of the reanalyses considered here. The present chapter is not the place for a complete study of that kind, and instead my purpose is to extract those portions that provide a basis for comparison with other languages.

17 Functional Perspectives on Syntactic Change

MARIANNE MITHUN

Functionalist approaches to linguistics rest on the fundamental assumption, underlying a broad spectrum of work, that language is shaped by its use. Functionalism represents a point of departure rather than a unified theory or codified model of language, but it does have important theoretical implications. It implies that the ultimate goal of linguistics goes beyond description (as in structuralism) and even generalization (as in typology) to explanation of an inclusive kind.

Of course much modern linguistic theory seeks to be explanatory in some sense. Under some approaches, explanation has been framed chiefly in terms of theory-internal consistency. A model of language is constructed and described in terms of abstract, inherent structural principles. Individual constructions are then explained by their conformity with the principles. Functional explanations have tended to be wider ranging, encompassing both language-internal and language-external considerations. Linguistic structures are seen to be shaped by a variety of forces, including the many physiological, cognitive, and contextual factors involved in their acquisition and use. Pertinent physiological factors include, for example, the motor abilities that constrain articulation. Cognitive factors include general capabilities rather than specific linguistic structures, such capacities as memory, pattern recognition, abstraction, generalization, and routinization of repeated tasks. Contextual factors represent perhaps the largest and most varied set, including text structure, communicative goals, language contact, and the myriad other features of the extralinguistic context that can affect the way communication and ultimately language are shaped. These three kinds of factors, physiological, cognitive, and contextual, are intertwined in most communication. Because communication is effected by all components of the linguistic system working in concert, value has been placed increasingly on considering linguistic structures within the context of the grammar as a whole, and within the context of communication, thought, and interaction. As a result, functionally oriented work has been based, where possible, on spontaneous speech recorded in its natural setting.¹

Few modern functionalists would maintain that there is a synchronic, one-to-one correspondence between linguistic form and function. Synchronic systems are understood as the historical products of sequences of individual diachronic events, each motivated in one way or another at the time it occurs. The diachronic dimension thus plays a key role in explanation. This focus contrasts with the secondary role accorded diachrony under some theoretical approaches in which primary attention is paid to those aspects of language hypothesized to be innate and thus immune to change. Under such approaches, language change has sometimes been viewed more as a phenomenon to be explained in terms of synchronic constraints, or as evidence for particular universal structures. As a result, the kinds of phenomena investigated have varied. Functionalist approaches have tended to focus on those aspects of language that do change, that can be seen to be shaped by processes of acquisition and use. Arbitrariness is recognized as an integral feature of grammar, but explanations are sought for the development of arbitrariness as well. Perhaps the most fundamental source of apparent arbitrariness is the process of grammaticization, the cognitive routinization of recurring structures. When the individual decisions involved in building complex expressions are automated, fine judgments need not be made each time a structure is used. The French subjunctive, for example, could be seen to have a basic irrealis function, but speakers do not evaluate the degree of reality of the situation at hand before they utter every subjunctive form. Its use is triggered automatically by certain grammatical and lexical contexts. Such arbitrariness is itself quite functional: the automation of whole structures frees the mind for attention to more novel aspects of the message (Mithun 1989). Arbitrariness can also result from processes of change. As is well known, grammatical changes that simplify one area of the grammar often complicate others. Furthermore, the ongoing process of syntactic change can also create arbitrariness when the motivation behind one change is obscured by the next.

The explanation of syntactic change in terms of communicative function is not new. In quite early work one finds an assumption that when the communicative efficacy of language is impaired in one way, speakers instigate compensatory changes. Harris and Campbell (1995: 21–3) point to early scholars who explained the rigidification of word order by the loss of inflectional case, beginning with Ibn Khaldūn in the fourteenth century on Arabic (Owens 1988: 270) and continuing with Bernard Lamy in 1675 on French (Scaglione 1981: 41). Adam Smith (1761) and Johann Herder (1772) held similar views on the motivation of language change in general. Cognitive abilities involved in the acquisition and use of language have also long been adduced as forces shaping language change. In 1816, Franz Bopp explained the development of the Indo-European infinitive in terms of the reanalysis of an original nominal form as a verb (Disterheft 1980). Hermann Paul's 1880 discussion of analogy and restructuring in grammatical change emphasizes the role of pattern recognition, reanalysis, and extension by both children and adults (Paul 1880). The importance of the cognitive routinization of repeated tasks, resulting in the

grammaticization of frequently used syntactic and morphological structures, was appreciated by a number of early comparativists and discussed eloquently by Meillet in 1912.² Aspects of the context in which communication takes place have long been noted in discussions of change. The role of language contact, for example, was discussed as early as the eleventh century by Ibn Hazm of Cordova (Harris and Campbell 1995: 33). When Adam Smith (1761) attributed the rigidification of word order to the loss of case inflection, he located the ultimate cause of the change in language shift: inflectional categories were lost as adults learned a second language imperfectly. All of these lines of research have continued to the present day with increasing sophistication and rewards, as more has been learned about individual languages and as general patterns have been compared. The role of functional considerations such as these in the understanding of syntactic change will be illustrated in the following sections.

1 Routinization and Reanalysis: The Yup'ik Subordinate

A long-recognized capacity of the human mind is the ability to automate repeated tasks. This process is one of the most powerful forces shaping grammar on several levels of structure. Over time, frequently recurring discourse patterns can become routinized in syntactic constructions. Such a process has been hypothesized to underlie the development of English complement constructions, for example. They are assumed to have evolved from series of two clauses, the first containing a demonstrative *that* which points cataphorically to the fact stated in the second (Allen 1980). Independent words that recur frequently in certain constructions can evolve into grammatical particles, clitics, and affixes. Such a process can be seen in progress in the evolution of the English word *full* into the adjective-forming suffix *-ful* of *beauti-ful* and *grace-ful*. As pre-formed templates, the grammatical structures that result from such processes require less attention from both speaker and hearer during the production and understanding of speech. A second well-known cognitive capacity is the ability to abstract patterns. Such processes are easily observable as children acquire their first language, producing along the way forms that reflect overgeneralizations or alternate analyses of existing patterns. A third familiar ability is the extension of recognized patterns to new contexts, observable as speakers exploit the tools at hand for new expressive needs.

These abilities can play important roles in the shaping of syntactic structures. They can be seen, for example, to underlie a syntactic construction in Central Alaskan Yup'ik, an Eskimo-Aleut language spoken in southwestern Alaska. In Yup'ik, as in all Eskimoan languages, both nouns and verbs consist of an initial root, any number of post-bases (primarily derivational suffixes), and a final inflectional ending. For nouns, the ending marks number and case. Possession can be expressed by a transitive pronominal suffix specifying the possessor and

the possessum. For verbs, the ending consists of a mood marker and a pronominal suffix complex specifying the core arguments of the clause. A sample noun ('my grandmother') and verb ('she told me about it') can be seen in (1).³

(1) Yup'ik sentence (Elizabeth Ali, speaker):

<i>Maurluma-llu</i>	<i>waten,</i>
<i>maurlur-m-a=llu</i>	<i>waten</i>
grandmother-ERGATIVE-1SG/3SG=too like.this	
"And my grandmother	
<i>qanemcillrua</i>	
<i>qanemci-llru-a-a</i>	
tell.about-PAST-INDICATIVE.TRANSITIVE-3SG/1SG	
told me this story"	

Among the Yup'ik mood suffixes are some that express common modal distinctions, such as the indicative, the interrogative, and the optative (for polite commands), and others that function primarily to link clauses in various ways, namely the subordinative, the participial, and a set of connective moods: several contemporatives ('while,' 'as,' 'when in the past'), the precessive ('before'), the concessive ('although, even if'), the contingent ('whenever'), the consequential ('because'), and the conditional ('if, when in the future'). Of special interest here is the mood referred to as the subordinative.

Subordinative clauses are frequent in spontaneous Yup'ik speech, often corresponding to what would be packaged as independent clauses in English. In the passage in (2) the speaker, Mrs Charles, described the transport of a butchered moose across a portage. The pieces of meat were to be shared by two families:

(2) Yup'ik subordinative mood *-lu* (Elena Charles, speaker):

- a. *Tekitcagnek*
tekite-ute-agnek
arrive-CONTEMPORATIVE.III-3DU
"When the two of them arrived,
- b. *teguqurluki*
tegu-qur-lu-ki
take.by.hand-repeatedly-SUBORDINATIVE-R/3PL
they took the pieces one by one (SUBORDINATIVE)
- c. *angyam* *keluani*
angyar-m *kelu-ani*
boat-ERGATIVE area.behind-3SG/3SG-LOCATIVE
elliluki.
elli-lu-ki
place-SUBORDINATIVE-R/3PL
and placed them behind the boat (SUBORDINATIVE).

- d. *Nangengata-ll'*,
nange-nga-ata=llu
 used.up-CONSEQUENTIAL-3PL=and
 And when they were finished,
- e. *ellait ucilirluteng*,
ellait uci-lir-lu-teng
 they.ERGATIVE cargo-make-SUBORDINATIVE-3PL
 they packed up (SUBORDINATIVE),
- f. *avegluki*
aveg-lu-ki
 divide.in.half-SUBORDINATIVE-R/3PL
 separating them into two portions (SUBORDINATIVE)"

The subordinative mood *-lu-* serves to link actions or states that are portrayed as related elements of a larger event or episode.

The subordinative construction includes a grammatical requirement that the subjects of all subordinative verbs must be coreferent with the subject of a main clause (though the specification of the higher subject is not always explicit). The abbreviation R in the glosses of the pronominal suffixes in (2) indicates that the argument is coreferent with the overarching subject, the two people loading the boat. Sentences like that in (3) are unambiguous. Gender is not distinguished in Yup'ik, but the subject of the verb 'leave' must be coreferent with that of 'watch':

- (3) Subject coreference in subordinatives (Elizabeth Charles Ali, speaker):

<i>wangakii</i>	<i>ayagluni</i>
<i>tanvag-ke-ii</i>	<i>ayag-lu-ni</i>
look.at-PARTICIPIAL.TRANSITIVE-3SG/3SG	leave-SUBORDINATIVE-3SG
"He watched her as he went"	

The Yup'ik subordinative could be approached in several ways. Most historical linguists would begin by seeking the source of the subordinative marker. Because the construction exists essentially as such in all of the modern Eskimo-Aleut languages, its origins cannot be reconstructed from comparative evidence. There is no attestation of an earlier stage of development in historical documents. The modern languages do provide a clue, however. Fortescue et al. (1994: 410) propose a connection between the subordinative suffix *-lu* and the enclitic *=llu* 'and, and also, too' that persists in all of the languages. In the standard Yup'ik orthography, used here, the digraph *ll* stands for a voiceless lateral *l̥*. The voiced *l* of the subordinative suffix *-lu* is automatically devoiced following a voiceless segment, so it actually has two variants: *-lu* and *-llu*. One approach to the reconstruction of the subordinative construction would be to stop at this point, having determined that the subordinative suffix may be

descended from a conjunction meaning 'and' and citing the requirement of subject coreference as unsurprising evidence of the universality of the subject category.

The construction holds further interest for a functional approach to diachronic syntax, however. It exemplifies the kind of syntactic construction that results from the routinization of a recurring discourse pattern. In Yup'ik, as in the other Eskimoan languages, the general pragmatic relation of a sentence to the preceding discourse may be indicated by the enclitic =*llu*. Such a link can be seen in (2d): "[They took the pieces one by one and placed them behind the boat.] And when they were finished." It appears that sequences of clauses that were especially closely related pragmatically, sharing the same subject, came to represent a recognizable complex construction in themselves. Repeated use resulted in the routinization or grammaticization of the discourse pattern. As the complex construction became routinized, a kind of reanalysis occurred. The conjunction *llu* became increasingly fused with the preceding constituent, first to an enclitic as =*llu* 'and,' and then, in one construction, to a verbal suffix *-lu*. The suffix was then reanalyzed as a member of the inflectional mood paradigm, complementary in function to other moods marked by verbal suffixes, such as the indicative.

The fact that the subordinative construction requires subject coreference is also of interest. In general, the grammar of Yup'ik shows strong ergative/absolutive patterning. Both the case suffixes on nouns and the pronominal suffixes on indicative verbs represent ergative and absolutive categories. If, as in some current theories, the category of subject is considered a purely structural phenomenon, its unique role in the subordinative construction makes little sense. Once its function is taken into account, however, its prominence in just this area of the grammar is easily understood. We know that speakers' choices of subjects are not random. Given an array of participants in an event, certain preferences emerge. Semantic agents tend to be preferred over semantic patients. First persons are preferred over second, and second over third. Humans are preferred over animals, and animals over inanimate objects. Identifiable (definite) arguments are preferred over unidentifiable (indefinite) ones (Silverstein 1976; Chafe 1994: chs 7–8; and others). Thus in spontaneous English speech we find sentences like *Sam grabbed the ball* more often than sentences like *The ball was grabbed by Sam*; sentences like *I saw your mother yesterday* more often than *Your mother saw me yesterday*; sentences like *He was hit by a car* more often than sentences like *A car hit him*; sentences like *She ate the last cookie* more often than *The last cookie was eaten by her*; and sentences like *Sally met a man in the produce section* more often than *A man met Sally in the produce section* (Chafe 1994). None of these preferences determines subject choice on its own. The observed preferences reflect the general function of subjects: they serve as a point of departure for the clause. Semantic agents tend to initiate actions. Speakers tend to present information from their own point of view (thus the person and animacy hierarchies). Speakers typically take common knowledge as a point of departure then move on to what is new. Of importance here is the fact that closely

associated clauses tend to share a common point of departure. For this reason, clause-combining constructions like the Yup'ik subordinative that link clauses portrayed as elements of a larger event frequently show subject continuity.

The shaping of the Yup'ik subordinative illustrates the inseparability of cognitive and contextual factors in the development of syntactic constructions. The cognitive routinization of the construction took place because of the frequent occurrence of a certain discourse pattern. Repeated use of the marker led to an erosion in form, which ultimately led to a functional and structural reanalysis of the conjunction as an inflectional mood suffix.

2 The Extension of Patterns for New Communicative Functions: The Yup'ik Past Contemporative

Most historical linguists recognize the extension of an existing pattern to a new domain as a force in syntactic change. Different approaches to diachronic syntax have tended to focus on different aspects of the process, however. For some, extension has been seen primarily as a simple generalization of structure. For some it has been viewed simply as one entry in a catalog of possible kinds of change, the limits of which are to be explored. Functional approaches focus on the reasons motivating changes of this kind: the expressive needs of speakers. Such an approach can be illustrated with the evolution of another Yup'ik mood marker.

One of the Yup'ik contemporative mood suffixes, the past contemporative *-llet-*, is usually translated 'when' (in the past). It is used to situate one event in time with respect to another:

- (4) Yup'ik past contemporative *-llet-* 'when' (Elena Charles, speaker):

<i>Pugellrani</i>	<i>nutqarnii</i>
<i>puge-llet-ani</i>	<i>nuteg-qar-na-nga</i>
surface-PAST.CONTEMPORATIVE-3SG	shoot-at.once-SUBORDINATIVE-3SG
<i>egmian</i>	
<i>egmian</i>	
immediately	
"When it surfaced, I shot immediately"	

Comparative evidence indicates that the past contemporative was not present in Proto-Eskimo-Aleut or even Proto-Eskimo. Its diachronic source is easy to identify, however. It is descended from a past nominalizer, a derivational suffix that is reconstructed for Proto-Eskimo by Fortescue et al. as **-lɔɔ-* (Yup'ik orthographic *ll* is [l], *e* is [ə], and *r* is [ɾ]; velar and uvular fricatives regularly alternate with stops in final position):

(5) Proto-Eskimo derivational source:

Proto-Eskimoan	*- <i>təʔ</i>	past nominalizer (participial or action)
Central Alaskan Yup'ik	- <i>təq</i>	'former, one that (has) . . . , act or state of'
Alaskan Alutiq Yupik	- <i>təq</i>	'former, one that has -ed, or was -ed'
Naukanski Yupik	- <i>təq</i>	'action of . . . -ing'
Central Siberian Yupik	- <i>təq</i>	'one that (has) . . . -ed, or has been . . . -ed, act of . . .'
Sirenikski	- <i>təx</i>	'action of . . . -ing'
North Alaskan Inuit Malimiut	- <i>tiq</i>	'action, result of . . . -ing' (Fortescue et al. 1994: 408–9)

The past nominalizer persists in modern Yup'ik as well. Its use can be seen in (6):

(6) Yup'ik derivational nominalizer *-ller-* (Elizabeth Ali, speaker):

Waten qanrutellrua
waten qaner-ute-llru-a-a
 like.this speak-to-PAST-INDICATIVE.TRANS-3SG/3SG
ilurani-gguq
ilurar-ni=gguq
 friend-R.SG/3SG=HEARSAY
 "He told his friend
ak'a-gguq niitelleq-gguq
ak'a-ggut niite-ller=gguq
 past=HEARSAY hear-PAST.NOMINALIZER=HEARSAY
what he had heard"

The shift from nominalizer to subordinator did not occur in a single leap. Traces of its diachronic source remain in the past contemporative construction. As noted earlier, nouns carry inflectional endings indicating number, case, and possession. Possession is shown by a transitive pronominal suffix specifying both the possessor and the possessum. The noun 'boat' in (7) contains a suffix indicating a third person plural possessor and the third person singular boat, followed by the locative case marker:

(7) Yup'ik inflection of nouns (Elizabeth Ali, speaker):

angyaat-ni
angyar-at-ni
 boat-3PL/3SG-LOCATIVE
 "at/in their boat"

Each of the mood markers in Yup'ik is associated with a particular paradigm of pronominal suffixes. For the most part, verbs in the connective moods share the same paradigm. Intransitive verbs in the past contemporative mood are inflected differently, however. They still carry the possessive suffixes used with nouns, followed by the locative case marker:

- (8) Yup'ik past connective with possessive pronouns (Elizabeth Ali, speaker):

<i>tangvagkai</i>	<i>ayallratni</i>
<i>tangvag-ke-ai</i>	<i>ayag-ller-atni</i>
watch-PARTICIPIAL-3SG/3PL	leave-PAST.CONTEMPORATIVE-3PL
"He watched them as they were leaving" (' <u>at their</u> leaving')	

It is clear, however, that past contemporatives like *ayallratni* 'as they were leaving' are no longer analyzed as nominal constructions. They have been reanalyzed as verbs. In Yup'ik, possessive nouns are identified by an ergative case suffix. The ergative can be seen in its genitive function in (9), where it marks the man as the possessor:

- (9) Yup'ik ergative possessor (Elizabeth Ali, speaker):

<i>angutem</i>	<i>angyaani</i>
<i>angute-m</i>	<i>angyar-ani</i>
man-ERGATIVE	boat-3SG/3SG.LOCATIVE
"in the man's (ERGATIVE) boat"	

In past contemporative constructions like 'when the man left,' the noun 'man' is no longer classified grammatically as a possessor. It appears in the absolutive case, as the only core argument of the intransitive clause '(when) the man left':

- (10) Yup'ik absolutive case with past contemporative (Elizabeth Ali, speaker):

<i>angun</i>	<i>ayallrani</i>
<i>angun</i>	<i>ayag-ller-ani</i>
man.ABSOLUTIVE	leave-PAST.CONTEMPORATIVE-3SG
"when the man (ABSOLUTIVE) left"	

In transitive clauses, the traces of the nominal source of the past contemporative are disappearing. The past contemporative mood is now usually followed by the transitive pronominal suffixes that appear with verbs in other connective moods:

- (11) Yup'ik transitive past contemporative:

<i>tangallraki</i>
<i>tangag-ller-aki</i>
watch-PAST.CONTEMPORATIVE-3SG/3PL
"when he watched them"

The possessive counterpart of the 3SG/3PL suffix for nouns would be *-atni*: *angya-atni* 'in his boats.' Yet even with transitives the reanalysis was not instantaneous. Alternations persisting in the modern language between nominal and verbal endings show that the past contemporative construction is still in the process of evolving. Yup'ik speakers accept both *tangallr-atni* (with nominal ending) and *tangallr-aki* (with verbal ending) for 'when he watched them.'

The extension of the past nominalizer to an inflectional mood marker has been gradual, taking place in small, tentative steps, the kind of increments that are possible only for changes shaped by use. The source structure was a possessive construction, consisting of a noun referring to the possessor in the ergative (= genitive) case, and a nominalized verb containing possessive and locative case suffixes ('at their leaving'). As the function of the construction began to shift, the nominalizing suffix split from its derivational source and took its place in the inflectional mood paradigm used with verbs. The noun referring to the possessor, originally marked with an ergative suffix, was coded as an absolutive, the sole argument of an intransitive clause. Next, the endings on the nominalized verb began to shift. On transitives, the possessive suffixes began to be replaced by the pronominal suffixes used with other connective moods, a shift that is still in progress. On intransitives, the replacement has not yet taken place.

Comparative evidence shows that the evolution of the past contemporative is part of a larger constellation of similar processes, all involving the extension of derivational suffixes to new functions as inflectional mood markers. Jakobson (1982) lays out the range of nominalizing constructions in modern Yup'ik along a continuum, from those which are still primarily nominal at one extreme, to those which are primarily verbal. The gradual evolution of the system as a whole indicates even more clearly that such extensions become established in the grammar slowly through use, rather than instantaneously as the result of a single structural reanalysis.

Also of interest is the fact that extension of this type, in which nominalization evolves into subordination, is not uncommon cross-linguistically. A functional analysis might go beyond documentation of the frequency of the shift to a consideration of why this particular development should occur so often, of what might stimulate speakers to make this particular leap. A possible explanation might lie in the function of the nominalizer, which can allow speakers to reify an action. The nominalization of whole clauses permits speakers to treat events as entities rather than independent predications, entities that can be integrated into larger sentences.

3 Language as an Integrated Tool of Communication: Aleut Clause Structure

An important consideration in much functional work is the fact that all aspects of the grammatical system work in concert for purposes of communication.

For this reason, the study of an individual syntactic construction in isolation can fail to yield the same kind of understanding that might be possible when the language is considered as a whole. An example of the interaction of different parts of the grammar can be seen in Aleut, the sole representative of the second branch of the Eskimo-Aleut family. Aleut is spoken on the Aleutian, Pribilof, and Commander Islands off Alaska and Siberia. The language and its relation to the Eskimoan languages have been described by Knut Bergsland in a number of articles, especially Bergsland (1986, 1989, 1997), and a magnificent dictionary (1994). Of special interest is the language's unusual clause structure.

Grammatical relations are indicated in Aleut by pronominal endings on verbs and case suffixes on nouns. In intransitive clauses, the verb carries a pronominal ending referring to the single core argument. For first and second persons, the ending is a pronominal enclitic. For third persons, it is a suffix distinguishing number. A verb alone can function as a clause in itself, with reference to the argument specified by the pronominal ending (examples cited here are from the Atkan dialect):

(12) Aleut intransitive verbs:

<i>awakuqing</i>	<i>awakuxt̄xin</i>
<i>awa-ku-χ=ting</i>	<i>awa-ku-χ=t̄xin</i>
work-PRESENT-SG=1	work-PRESENT-SG=2
"I am working"	"you are working"
<i>awakuχ</i>	<i>awakus</i>
<i>awa-ku-χ</i>	<i>awa-ku-s</i>
work-PRESENT-SG	work-PRESENT-PL
"he or she is working"	"they are working" (Bergsland 1989: 4)

Third person arguments may also be identified by a noun containing a suffix that distinguishes number. The suffixes match those that appear on verbs: *-χ* for singulars, *-(i)χ* for duals, and *-s* for plurals.

(13) Aleut intransitives with nominal arguments:

<i>Tayaguχ awakuχ</i>	<i>Tayagus awakus</i>
<i>tayagu-χ awa-ku-χ</i>	<i>tayagu-s awa-ku-s</i>
man-SG work-PRESENT-SG	man-PL work-PRESENT-PL
"The man is working"	"The men are working" (Bergsland 1989: 9)

In clauses with two nominal core arguments, both nominals show the same suffixes. Definiteness is not distinguished:

(14) Aleut transitive with nominal arguments:

a. <i>Tayaguχ qax</i>	<i>qakuχ</i>
<i>tayagu-χ qa-χ</i>	<i>qa-ku-χ</i>
man-SG fish-SG eat-PRESENT-SG	
"The man is eating the/a fish"	

- b. *Aniqdus huzungis ataqan kanfiixtax atxazazakus*
Aniqdu-s huzungis-s ataqan kanfiixta-x atxazaza-ku-s
 child-PL all-PL one candy-SG get-DISTRIBUTIVE-PRESENT-PL
 "All of the children got one candy each" (Bergsland 1989: 7, 1994: 499)

If the semantic agent of a clause with two core arguments is not represented by a separate nominal, it is still specified pronominally by the suffix on the verb (the tense glossed as present is used both for ongoing events and immediate pasts, those of current relevance):

- (15) Pronominal agent:

sabaaka-x asxati-ku-s
 dog-SG kill-PRESENT-3PL
 "They just killed a/the dog" (Bergsland 1997: 15)

If, however, the semantic patient is not represented by a separate nominal, the structure of the clause changes. The agent nominal carries the suffix *-m*, identified by Bergsland as an ergative:

- (16) Aleut transitive with pronominal patient:

Tayagum qakuu
tayagu-m qa-ku-a
 man-ERGATIVE eat-PRESENT-3SG.TR
 "The man is eating it" (Bergsland 1989: 7)

The suffix on the verb changes as well. In intransitive sentences like "The man is working" in (13), and sentences with two nominals like "The man is eating fish" in (14), the ending is *-x*, matching that on the agent noun 'man.' In transitive clauses without a separate patient noun, however, the ending changes. A comparison of the sentences in (17) shows that the pronominal suffix on the verb suffix specifies the patient or absolutive (in the plural, both the ergative and absolutive case suffixes on nouns appear as *-s*):

- (17) Aleut transitives with pronominal patients:

hla-m kidu-qa-a
 boy-ERGATIVE.SG help-REMOTE.PAST-3SG.TR
 "The boy helped him"

hla-s kidu-qa-a
 boy-PL help-REMOTE.PAST-3SG.TR
 "The boys helped him"

hla-m kidu-qa-ngis
 boy-ERGATIVE.SG help-REMOTE.PAST-3PL.TR
 "The boy helped them" (Bergsland 1997: 13)

If the clause contains no independent nouns at all, the pronominal suffix on the verb represents a combination of the agent and patient, but only one is mentioned overtly. If both arguments are singular, the singular suffix *-a* is used. If either or both are dual, the dual suffix *-kix* is used. If either or both are plural, the plural suffix *-(ng)is* is used (there is no gender distinction in the language):

(18) Aleut transitive pronominal suffixes:

3SG/3SG	<i>-a</i>
3DU/3SG, 3SG/3DU	<i>kix</i>
3PL/3SG, 3PL/3DU, 3SG/3PL, 3DU/3PL	<i>-(ng)is</i> (Bergsland 1997: 13)

The system can result in ambiguity, as can be seen from the translation of (19), but since the pronominal suffixes are only used anaphorically to refer to already established referents, the ambiguity is seldom a problem:

(19) Potential ambiguity:

kidu-qa-ngis
 help-REMOTE.PAST-3PL.TR
 "he helped them," "they helped him," "they helped them" (Bergsland 1997: 15)

We thus have an unusual system in which ergative marking appears on the agent noun, and transitive suffixes appear on the verb, but only when the semantic patient is pronominal (anaphoric). Why should such a system exist? Comparative evidence shows that it evolved from a system essentially like that of its Eskimoan relatives, to which we now briefly return. The Eskimoan languages show a straightforward ergative/absolute pattern. Grammatical relations are expressed by pronominal suffixes on verbs and case suffixes on nouns. The pronominal suffixes refer to two participants if the verb is transitive, and to one if it is intransitive, whether independent nominals are present or not (as in Aleut, absolutes are distinguished by their lack of case marking, but they do carry number suffixes):

(20) Yup'ik case (George Charles, speaker):

- a. *Arnam* *neqa*
arnar-m *neqa*
 woman-ERGATIVE fish-(ABSOLUTIVE)
neraa
nere-a-a
 eat-INDICATIVE.TRANSITIVE-3SG/3SG
 "The woman ate the fish"
- b. *Arnaq* *iptuq*
arnar *ipete-u-q*
 woman-(ABSOLUTIVE) disappear-INDICATIVE.INTRANSITIVE-3SG
 "The woman disappeared"

- c. *Neqa* *iptuq*
neqa *ipete-u-q*
 fish-(ABSOLUTE) disappear-INDICATIVE.INTRANSITIVE-3SG
 "The fish disappeared"

The verbs may stand alone as full clauses in themselves with no change in form. Pronominal reference comes from the pronominal suffixes: *neraa* 'she ate it,' *iptuq* 'she disappeared.'

Many Yup'ik verb stems are ambitransitive, that is, they may be inflected either as transitives or intransitives. The verb *ner-* 'eat' is inflected as a transitive in (20a) above, and as an intransitive in (21):

- (21) Intransitive inflection of ambitransitive verb (George Charles, speaker):

Arnaq *ner'uq*
arnar *ner-e-u-q*
 woman-(ABSOLUTE) eat-INDICATIVE.INTRANSITIVE-3SG
 "The woman ate"

An important feature of Yup'ik syntax is the fact that transitive absolutes must be identifiable (definite). If the semantic patient of an action is indefinite, it must be expressed as an oblique, in Yup'ik the ablative. The clause is then grammatically intransitive:

- (22) Intransitive clause with oblique patient (George Charles, speaker):

Arnaq *neqamek* *ner'uq*
arnar *neqa-mek* *ner-e-u-q*
 woman-(ABSOLUTE) fish-ABLATIVE eat-INDICATIVE.INTRANSITIVE-3SG
 "The woman ate a fish"

Such a grammatical requirement is actually not unusual cross-linguistically. Kapampangan, for example, an ergative language of the Philippines, shows the same restriction on transitive absolutes as Yup'ik (Mithun 1994). In essence, in these languages syntactically transitive constructions require a high degree of transitivity in the sense of Hopper and Thompson (1984). If a semantic patient is indefinite or incompletely affected by an event, the event is expressed as a syntactic intransitive.

Aleut shows a surprising departure from the relatively common, stable system found throughout the Eskimoan languages. The requirement that a semantic patient be definite in transitive clauses has evolved into a requirement that the semantic patient be pronominal (anaphoric). It is only under these circumstances that the ergative suffix *-m* can appear on the agent noun and that the transitive suffixes can appear on the verb. This typologically strange development was stimulated by a change in another part of the grammar. Bergsland reports that final syllables in Aleut underwent phonological

reduction. As a result, three of the Proto-Eskimo-Aleut case suffixes, the Proto-Eskimo-Aleut ergative **-m*, ablative/instrumental **-mek*, and locative **-mi*, merged into a single Aleut form: *-m*. The merger of the distinction between the original ergative **-m* and oblique **-mek* would have caused havoc in the existing system, in which *-m* marked ergative agents and *-mek* oblique patients. The same form would be used to mark contrasting functions. In sentences corresponding to the Yup'ik "The woman ate the fish" in (20a), the suffix *-m* would mark the semantic agent, but in sentences corresponding to "The woman ate a fish" in (22), the same suffix *-m* would mark the (formerly oblique) semantic patient. The syncretism of the cases would have seriously impeded communication.

The remedy is understandable in terms of the structure at the time. In the original system, only identifiable (definite) nominals could serve as transitive absolutes. The most identifiable arguments are of course those that can be represented by pronouns. This is just the context in which traces of the original transitive construction have remained in Aleut, clauses with pronominal transitive absolutes. The original ergative marker remains, but the context has been narrowed from all clauses containing identifiable absolutes of any kind to only those containing pronominal (anaphoric) absolutes, without independent noun phrases. In the parent language, all core arguments were represented by pronominal suffixes on the verbs, whether additional nominals were present in the clause or not. In modern Aleut, only those transitive arguments not identified by separate nouns are represented by the pronominal suffixes. As Bergsland points out, the Aleut transitive suffixes on verbs are derived from a subset of the transitive suffixes on Proto-Eskimo-Aleut verbs: Aleut singular *-a* is cognate with Yup'ik *-a* 3SG/3SG, Aleut dual *-kix* is cognate with Yup'ik *-ke-k* 3DU/3DU, and Aleut plural *-(ng)is* is cognate with Yup'ik *(ng)i-t* 3PL/3PL. He notes that the Aleut forms are clearly innovations, reductions of the earlier, more elaborate system.

The unusual evolution of the original ergative system has led to a number of other innovations within Aleut. The special treatment of pronominal (anaphoric) arguments in clauses has been extended to possessive constructions. In Proto-Eskimo-Aleut, as in the modern Eskimoan languages, nouns referring to possessors carry ergative suffixes, and nouns referring to possessions carry transitive suffixes specifying the possessor and possessum. These are similar in form to the transitive suffixes that appear on indicative verbs. When Aleut clause structure became sensitive to the difference between nominal and pronominal arguments, possessive constructions underwent a similar development. Now the possessor is specified pronominally on the possessum only if it is not represented by an independent nominal. Proto-Eskimo-Aleut also contained a locative case suffix **-mi*, which became indistinguishable from the ergative and ablative due to the phonological changes mentioned above. As a result, locatives can no longer be expressed inflectionally in Aleut, but only analytically in a phrase. Finally, the changes in the specification of grammatical relations have affected Aleut word order. As seen in (14a) above ("The man is

eating the/a fish”), if both core arguments are represented by nouns, neither noun carries case marking. As a result, constituent order has become quite rigid, nearly invariant SOV, in contrast with the fluid order of the Eskimoan languages.

The syntactic structure of modern Aleut becomes explicable once the diachronic processes involved in its development are considered. Massive syntactic restructuring was triggered by phonological changes that affected the shapes of morphological markers. The changes in shape nearly destroyed the original case paradigm, which in turn compromised the efficacy of existing syntactic constructions. Such changes can only be explained when the language is considered as a whole, its parts interacting in communication. The changes would not have taken place if grammar were not shaped by its communicative function.

4 The Communicative Context: Conjunction

Perhaps the greatest variety of factors shaping language come from the context in which communication takes place. The effects of two of them can be seen in the evolution of one of the most basic syntactic constructions: coordinating conjunction. Conjunction might be assumed to be among the most universal and stable of constructions. Yet even among closely related languages we find unexpected variety, both in the degree to which coordination is grammaticized and in the inventories of coordinating constructions that exist (Mithun 1988). In many languages there are no grammaticized coordinating constructions whatsoever, and in many others the constructions that do exist can be seen to have evolved surprisingly recently.

Speakers and writers of European languages might wonder how a language could function without grammaticized coordination. An examination of spontaneous speech in its natural context quickly provides an answer: links among constituents can be shown by intonation. Coordination is typically signaled intonationally whether overt conjunctions are present or not. Very closely related constituents may be combined with little break in intonation. Somewhat looser bonds may be shown by “comma intonation,” usually a pause and a non-final pitch contour.

In a surprisingly large number of languages, the diachronic sources of coordinating constructions are easily traced because the constructions have come into the grammar so recently. Such a situation can be seen among the Northern Iroquoian languages of northeastern North America. Though not mutually intelligible, the languages share most of their morphological and syntactic patterns. Yet each shows a different coordinating construction. The basic coordinating conjunction in Cayuga, for example, is descended from a Proto-Northern-Iroquoian discourse particle **ohni?* ‘also, too,’ whose reflexes remain in all of the modern languages. In Cayuga, the particle has been reduced

to *hni?*. An example of the particle in its original use can be seen in (23). After he had selected a hammer, a customer in a hardware store was asked whether he needed anything else:

(23) Cayuga ‘also’ (Reginald Henry, speaker):

ghé? Enestanya?kthá? ki? hni? tewakatohwétsó:nih
 yes saw just too I want
 “Yes. I want a saw, too”

The path along which such a particle could develop into a conjunction is easy to see. The sentence in (24) was the answer to a question about what a family was going to plant:

(24) Cayuga coordination (Reginald Henry, speaker):

A:yé? akwé:, onghé? osahe?tá? ohon?atá?o hni?
 it.seems all corn bean potato.guess too
 “Oh, I guess everything, corn, beans, and potatoes”

With pauses separating the nouns, the potatoes could be interpreted as an afterthought, an extra addition to the list. The particle now occurs in contexts where it clearly could not mark an afterthought. A guest watching three children play asked their names. His host’s reply is in (25):

(25) Cayuga coordination (Reginald Henry, speaker):

Junior, Helen, Hercules hni?
 “Junior, Helen, and Hercules”

The particle does not yet appear with conjoined verbs or clauses, except in its original adverbial role. Verbs and clauses are usually linked simply by intonation.

The other Northern Iroquoian languages all contain coordinating conjunctions, but the forms are not cognate. Some developed along a route parallel to that of Cayuga *hni?*, like the Seneca *kho*, which evolved from a different particle meaning ‘too’ and also follows the final conjunct. Others developed along a slightly different path, arising from a particle that serves to link new sentences to the preceding context. Such a development can be seen in Mohawk. Historical documents indicate that there was no regular coordinating construction in Mohawk a century ago (Mithun 1988, 1992). Modern Mohawk, however, contains a fully grammaticized conjunction *tany?* ‘and’ that conjoins clauses, predicates, and nominals. The diachronic source of the conjunction can be seen both through comparative evidence and in the historical record.

A discourse particle *tá:* can be reconstructed for Proto-Northern-Iroquoian that functioned to tie new information to preceding discourse. It has reflexes

in most of the modern languages, usually at the beginning of paragraph-like units, and is translated variously 'and so,' 'so then,' 'so now,' and 'now then.' It appears pervasively in an extensive Mohawk text recorded in 1896–7 (Hewitt 1903) (Hewitt's orthography, which differs slightly from that used in Mohawk communities today, is retained in examples from his work):

(26) Mohawk discourse particle *tá:*:

[I am thinking that, perhaps, I should recover from my illness if ye would uproot the tree standing in my dooryard and if there beside the place from which ye uproot the tree I should lay myself in a position recumbent.]

Tá, e'thóne? né rao ñ kwéta? wahatiro ñ totáko?

so, at that time the his people they tree uprooted

"So thereupon his people uprooted the tree" (Hewitt 1903: 282.5)

The same texts show a compound particle *tahnú* 'furthermore, moreover,' apparently formed from the particle *tá:* and another particle *nú:wa* 'now.' Like the particle *tá:*, it often appears at the beginning of a new paragraph, relating the new information to preceding context, but it also precedes sentences and clauses within paragraphs:

(27) Early Mohawk *tahnó"?*:

E'thóne? wahátka?we? né djí ro?therakará:tato"?

at that time he let it go the where he basket held up

"Thereupon he released his hands from holding up the basket for her,

tahnó"? *e'thóne? neñ? sa:io"téñti?*

and at that time now she started homeward

and now, moreover, she started on her journey homeward.

Néñ tahnó"? *íáñ othéno"?* *teiókste?*

now and not anything it heavy is

Now, moreover, [the basket she carried] was not at all heavy" (Hewitt 1903: 278.7)

The particle *tahnú?* is no longer used in Mohawk, though one speaker remembers an elderly relative who used it. A descendent of the particle appears as a regular conjunction in modern Mohawk, the phonologically reduced, unstressed particle *tanyú?* 'and.' It is used to conjoin constituents of any type:

(28) Mohawk clause conjunction (Muriel Rice, speaker):

A:ke ne tsi náhe' natyakà:ʔA,

oh the so long I was out

"I was out a long time

tanyu? *katyuhkárya'ks*
and I am hungry
and I'm hungry"

(29) Mohawk nominal conjunction (Muriel Rice, speaker):

O'wà:ry *tanyu'* *osahè:ta'* *wakekhú:ni*
 meat and bean I food make
 "I'm cooking meat and beans"

It is striking that coordinating constructions in many languages of the world are relatively recent loans from European languages, languages with which they have been in contact for no more than a century or two. Bogoras (1922: 881) noted the presence in Kamchadal, a Luoravetlan language of Siberia, of local Russian conjunctions *i*, *dai* 'and,' *je* 'but,' *potom* 'after that,' and others. Texts in Tiwi, an Australian aboriginal language documented by Osborne, show the conjunction *and* (Osborne 1974). In his survey of Mesoamerican languages, Suárez notes that "in most of these [Mixe-Zoque] languages coordinating particles have been borrowed from Spanish, but in spite of that, coordination through mere juxtaposition (with different meanings according to context) is still very common" (1983: 109). In Tequistlatec-Jicaque languages, "constituents of the clause and clauses may be linked by coordinating particles; in Coastal Chontal some of these particles are native, but in Highland Chontal all particles with this function are borrowings from Spanish" (1983: 115). "Coordination is made largely through juxtaposition in Huixtan Tzotzil. In Tojolabal, the same mechanism is found, although there are coordinating particles borrowed from Spanish" (1983: 120). In Huave, "in most cases coordination is marked with particles borrowed from Spanish, and the constructions with a reduced second clause match the Spanish patterns so closely that these have probably been imitated too" (1983: 132). South American languages in contact with Spanish, such as Guaraní and Quechua, exhibit this phenomenon as well (Cole 1982: 78–80). The borrowing of conjunctions may be facilitated by a structural feature. Since they often occur at the edges of constructions, integrating them into a new language need cause relatively little syntactic disruption.

The prevalence of conjunctions borrowed from European languages may be due to another factor as well. The source languages for these borrowed conjunctions often have substantial literary traditions. Literacy itself may contribute to the development of grammaticized conjunctions in two ways. First, written language cannot exploit the powerful cue of intonation for indicating links among constituents. Punctuation can provide only a faint shadow of the fine gradations of pitch and rhythm available in spoken language. Second, written language has been shown to differ structurally from spoken language in important ways (Chafe 1985, 1987, 1994). Speakers, under constraints of memory and production time, typically produce syntactically simpler constructions than do writers. They tend to introduce only one important piece of

information per intonation unit. Writers, by contrast, have the luxury of time to produce long, elaborate sentences, embellishing earlier statements or rephrasing at will. Accordingly, written sentences are typically longer and packed more tightly with information. While speakers use more sentence-initial conjunctions than writers (32 versus 0.9 per 1000 words in a sample analyzed by Chafe), writers conjoin significantly more constituents within clauses (23.8 per 1000 words versus 9.9). Such differences can be seen today between modern spoken and written Mohawk. Relatively recently, Mohawk speakers have begun to write their language. The conjunction *tanyu'* 'and' appears considerably more frequently in their written Mohawk than in their speech. The development of systematic overt specification of grammatical relationships in literary languages is clearly functional, crucial for guiding readers through highly complex structures without the aid of intonation.

But why should contact with these languages result in the sudden grammaticization of coordinating constructions in spoken languages? Intonation in spoken language can indeed signal various degrees of linkage among constituents, but the precise nature of the links can be vague. Series of noun phrases may indicate open or closed sets of entities, alternatives, or apposition. The formal grammaticization of conjunction can provide systematic overt disambiguation. Series of intonationally linked clauses can show the same vague relationships. They may represent sequential events ('and then'), simultaneous situations ('and,' 'while'), a contrast ('while'), purpose ('in order to'), or items related in a number of other ways. Prior to the grammaticization of clause conjunction, relationships between juxtaposed clauses are usually interpreted from context, or, when necessary, specified by discourse adverbials. The grammaticization of coordination offers systematic specification of the relationship. The fact that this tool should be so easily borrowed, even by speakers who are not themselves literate in either the donor or the recipient language, confirms the power of expressive need in shaping grammar. Speakers constantly exploit and extend the devices available to them to meet new communicative needs. In language contact situations, there is no reason that devices available in one language should not be extended to communication in another. The forms themselves are apparently easily borrowed, as in Kamchadal, Tiwi, and the Mesomamerican languages cited above. The mere concept of overt expression of coordination appears to be easily borrowed as well. The Cayuga, Seneca, and Mohawk conjunctions were developed from discourse particles already present within the languages, but they evolved quite rapidly into markers of grammatical coordination just at the time that speakers were beginning to be educated in European languages, English for the Cayuga and Seneca, and French for the Mohawk. The sudden development of syntactic coordinating constructions under these conditions again illustrates the intertwining of cognitive and contextual factors in shaping syntactic structure. Stimulated by contact with other languages, speakers have reorganized their grammatical systems in order to increase their expressive resources for communication.

5 Conclusion

Functional approaches to syntactic change share a general assumption that languages are shaped in significant ways by the physiological, cognitive, and contextual circumstances surrounding their use. Functionalism is neither a codified theory nor a set of instructions for mechanical analysis: it does not offer formulae for discovering explanations in the way that the comparative method might provide procedures for reconstructing earlier sound systems. This characteristic is not unique to functionalist approaches; it is shared by all work on diachronic syntax. It is due to the nature of the subject matter. Syntactic change can be stimulated and facilitated by a wide variety of factors, often working in concert. Their presence in a language does not guarantee that a given change will take place, only that it may be rendered more likely. Examples abound of divergent developments in closely related languages that appear to share all major relevant structural and contextual properties. What is called for is careful consideration of all of the circumstances surrounding a change, both language-internal and language-external, that might have stimulated or facilitated it, and common sense in assessing their interrelationships. As more is learned about recurring constellations of phenomena, a clearer, more detailed picture should emerge of the kinds of forces that motivate specific changes and of their interaction.

NOTES

- 1 A survey of major synchronic functionalist work through the early 1980s can be found in Nichols (1984).
- 2 Further discussion of current work on grammaticization can be found in Bybee, Heine, and Traugott, this volume.
- 3 Yup'ik examples cited here come from the speech of members of the

Charles family of Bethel, Alaska. I am especially grateful to Elizabeth Charles Ali for her help in transcribing and analyzing the material. Examples are given here first in their surface forms and then, if appropriate or necessary, with an indication of their underlying morphemic segmentation.

Part VI

Pragmatico-Semantic Change

This page intentionally left blank

18 Grammaticalization

BERND HEINE

Grammaticalization theory is neither a theory of language nor of language change; its goal is to describe grammaticalization,¹ that is, the way grammatical forms arise and develop through space and time, and to explain why they are structured the way they are (see section 2). Grammaticalization is defined as a process² which is hypothesized to be essentially unidirectional³ (see section 3).

Grammaticalization is frequently described as leading from lexical to grammatical (= functional) categories. This view takes care of quite a number of linguistic phenomena, but it does not account for much of what happens in the development of grammatical categories. It suffers in particular from two main shortcomings. First, the process is not confined to the development of lexical forms; rather, grammatical forms themselves can, and frequently do, give rise to even more grammatical forms. Second, since linguistic items require specific contexts and constructions to undergo grammaticalization, grammaticalization theory is also concerned with the pragmatic and morphosyntactic environment in which this process occurs. While grammaticalization has both a synchronic and a diachronic dimension, its foundation is diachronic in nature. In the following we will distinguish between grammaticalization, which relates to specific linguistic phenomena, grammaticalization studies, which deal with the analysis of these phenomena, and grammaticalization theory, which proposes a descriptive and explanatory account of these phenomena (see section 2).

1 Earlier Work

In the history of grammaticalization studies, three main phases can be distinguished. The first phase is associated with the work of eighteenth-century French and British philosophers. Étienne Bonnot de Condillac claims that

grammatical complexity and abstract vocabulary derive historically from concrete lexemes. Condillac (1746) argued that tense suffixes and other verbal inflections can be traced back to independent words: the latter coalesce to give rise to verbal tense and aspect forms. Some notions of modern grammaticalization theory are also contained in the work of John Horne Tooke (1857). In his work, first published in 1786 and 1805, he argues that language in its "original stage" is concrete, and abstract phenomena are derived from concrete ones. Horne Tooke proposed "abbreviation" and "mutilation" as key notions: nouns and verbs are called "necessary words" while other word classes, like adverbs, prepositions, and conjunctions, are derived from "necessary words" via abbreviation and mutilation.

The second phase is associated mainly with German nineteenth-century linguists. The first main representative was Franz Bopp (1816, 1833), who considered the change from lexical to grammatical forms to be an essential component of his principles of comparative grammar. While various examples discussed by Bopp, in the same way as those proposed by his predecessors, are etymologically of doubtful value, a number of insights emerged in the course of his work. Bopp was but the first in a long series of nineteenth-century linguists for whom grammaticalization became a key notion (although the term was introduced only much later; see below), other authors being August Wilhelm von Schlegel (1818), Wilhelm von Humboldt (1825), Franz Wüllner (1831), William Dwight Whitney (1875), and, most of all, Georg von der Gabelentz (1901). After the turn of the century, grammaticalization studies declined.

No major developments took place in the course of the twentieth century prior to 1970. The few authors who made use of findings on grammaticalization, like Meillet (1912), who introduced the term (French: *grammaticalisation*), or Kuryłowicz (1965), were Indo-Europeanists who used findings on grammaticalization as part of their methodology in historical linguistics but did not contribute much beyond what had been known already by the end of the nineteenth century.

The third phase of grammaticalization studies started in the 1970s and was initially connected with the paradigm of localism (Anderson 1971, 1973). According to this school, spatial expressions are more basic than other kinds of linguistic expressions and the former therefore serve as structural templates for the latter. More importantly, however, developments in the early 1970s were connected with the work of Talmy Givón, who argued that in order to understand language structure one must have a knowledge of its earlier stages of development. With his slogan "Today's morphology is yesterday's syntax,"⁴ which he considered to be part of a more general cyclic evolution (see section 7), as sketched in (1), he opened a new perspective for understanding grammar (Givón 1971: 12, 1979):

(1) Discourse > Syntax > Morphology > Morphophonemics > Zero

In the course of the 1970s and 1980s a number of studies appeared, many of them concerned with problems of morphosyntactic change (see, e.g., the contributions in Li 1977), which were based on assumptions such as the following:

- i Language is a historical product and should therefore be accounted for first of all with reference to the historical forces that are responsible for its present structure.
- ii Accordingly, findings on grammaticalization offer more comprehensive explanations than findings confined to synchronic analysis could offer.
- iii As had already been claimed since Condillac's time, the development of grammatical categories is unidirectional, leading from concrete/lexical to abstract/grammatical meanings. (Traugott 1980; Heine and Reh 1982, 1984; Lehmann 1982; Bybee 1985)

While virtually all of the various authors adhering to that paradigm subscribe to the same general approach, according to which grammaticalization is defined as the development from lexical to grammatical and from grammatical to even more grammatical structures, a wide range of different opinions and theoretical orientations arose. In some of the works (e.g., Traugott 1980), the main contribution of this field consists in offering new ways of reconstructing semantic change. In other works, grammaticalization theory is viewed as a means of describing and explaining the structure of grammatical categories across languages (Bybee 1985; Bybee et al. 1991, 1994). Others again propose to treat grammaticalization as being synonymous, or nearly synonymous, with grammar: for Hopper (1987), in particular, grammaticalization, or emergent grammar, has to do with the recurrent strategies used for building discourses and involves a continual movement toward structure. Finally, there are those who argue that grammar is the result of an interplay between conceptualization and communication, and that grammaticalization theory provides a tool for reconstructing some of the extralinguistic foundations of grammar (Heine et al. 1991; Heine 1997b).

The diversity of views that have been voiced on grammaticalization is also reflected in the terminology employed: rather than "grammaticalization," some authors prefer to call it "grammaticization," or "grammatization." Furthermore, there are also major differences as to what subject matters should be subsumed under the term. For some, the term "grammaticalization" is merely an equivalent to "grammatical form"; such authors may say, for example, that language X has grammaticalized a dative case, which is roughly equivalent to saying that in X there exists a grammatical form for this case function.

A wealth of books and articles is now available, either as monographic treatments (Traugott and Heine 1991a, 1991b; Heine et al. 1991; Hopper and Traugott 1993; Pagliuca 1994; Ramat and Hopper 1998), or as applications of findings on grammaticalization to one particular language (e.g., Kilian-Hatz 1995 on Baka; Sun 1996 on Chinese; Diewald 1997 on German).

Furthermore, a number of works are devoted to the grammaticalization of specific parts of grammar, such as tense and aspect (Dahl 1985; Brinton 1988; Bybee and Dahl 1989; Fleischman 1982; Bybee et al. 1994; Kuteva 1998), modality (Traugott 1989; Bybee and Fleischman 1995), evidentials (Willett 1988), auxiliaries (Heine 1993; Kuteva 2001), copulas (Devitt 1990, 1994), serial verbs (Givón 1975; Lord 1993), demonstratives (Diessel 1999), definite articles (Greenberg 1978; Himmelmann 1997), indefinite articles (Givón 1981; Heine 1997b: 66–82), indefinite pronouns (Haspelmath 1997a), anaphora (Givón 1976; Frajzyngier 1987), reflexives (Kemmer 1993; König and Siemund 2000; Schladt 2000; Heine 2000), passives (Haspelmath 1990), temporal adverbs (Haspelmath 1997b), infinitives (Haspelmath 1990), quotatives (Ebert 1991; Saxena 1988, 1995; Güldemann 2001), clause subordinators (Genetti 1986, 1991; Traugott 1985, 1986; König 1985, 1988; Hopper and Traugott 1993: 176ff), complementizers (Ransom 1988), relative clauses (Lehmann 1984), numerals (Heine 1997b: 18–34), comparatives (Heine 1994, 1997b: 109–30), spatial orientation (Svorou 1994; Heine 1997b: 35–65), or possession (Heine 1997a).

More recent work shows that grammaticalization studies are equally relevant to understanding language change in situations of extreme language contact and unusual language transmission. There is now a wealth of studies on grammaticalization in pidgins and creoles (see, e.g., Sankoff and Brown 1976; Arends 1986; Plag 1992, 1993, forthcoming; Baker and Syea 1996, Bruyn 1995, 1996; Huber 1996; Mufwene 1996; Poplack and Tagliamonte 1996; Romaine 1995, 1999), and these studies suggest that (with few exceptions; cf. Bruyn 1996; Plag forthcoming), grammatical categories in these languages evolve along the same lines as in languages with “natural” language transmission.

2 The Framework

As observed earlier, grammaticalization theory is a theory to the extent that it offers an explanatory account of how and why grammatical categories arise and develop. It is based on the following assumption: the main motivation underlying grammaticalization is to communicate successfully. To this end, one salient human strategy consists in using linguistic forms for meanings that are concrete, easily accessible, and/or clearly delineated to also express less concrete, less easily accessible, and less clearly delineated meaning contents. To this end, lexical or less grammaticalized linguistic expressions are pressed into service for the expression of more grammaticalized functions.⁵ Accordingly, grammaticalization is a process whereby expressions for concrete (= source) meanings are used in specific contexts for encoding grammatical (= target) meanings. This process has a number of implications for the structure of the expressions concerned.

Technically, the grammaticalization of linguistic expressions involves four interrelated mechanisms:⁶

- i desemanticization (or “bleaching,” semantic reduction): loss in meaning content;
- ii extension (or context generalization): use in new contexts;
- iii decategorialization: loss in morphosyntactic properties characteristic of the source forms, including the loss of independent word status (cliticization, affixation);
- iv erosion (or “phonetic reduction”), that is, loss in phonetic substance.

Each of these mechanisms is concerned with a different aspect of language structure or language use: (i) relates to semantics, (ii) to pragmatics, (iii) to morphosyntax, and (iv) to phonetics. While three of these mechanisms involve a loss in properties, there are also gains: in the same way as linguistic items undergoing grammaticalization lose in semantic, morphosyntactic, and phonetic substance, they also gain in properties characteristic of their uses in new contexts (cf. (ii)), sometimes to the extent that their meaning may show little resemblance to the original meaning. None of the mechanisms is confined to grammaticalization (see Newmeyer 1998; Campbell 2001a); but to the extent that jointly they are responsible for grammaticalization taking place, they can be said to constitute different components of one and the same general process.

Each of these mechanisms gives rise to an evolution which can be described in the form of a three-stage model, called the overlap model (Heine 1993: 48–53). The stages concerned are as follows:

- i There is a linguistic expression A that is recruited for grammaticalization.
- ii This expression acquires a second use pattern, B, with the effect that there is ambiguity between A and B.
- iii Finally, A is lost, that is, there is now only B.

The result of this process is that grammaticalization exhibits a chain-like structure (see section 5). Note that not all instances of grammaticalization in fact proceed to stage (iii); it may happen that the process is arrested at stage (ii); however, once stage (iii) is reached, B tends to be conventionalized, that is, it turns into a new grammatical category.

Desemanticization results from the use of forms for concrete meanings which are reinterpreted in specific contexts as more abstract grammatical meanings (see section 5 for a more detailed discussion). While this term is commonly understood to refer to the loss of lexical content, an equally common type of desemanticization concerns cases where a grammatical form having two (or more) grammatical functions loses one (or all) of these functions. For example, the Old Swedish nominal inflections were typically portmanteau (cumulative) morphemes simultaneously expressing gender, number, and case. Desemanticization in this case had the effect that one of the three functions, namely case, was lost in the development to modern Swedish (Norde 2001: 243).

The term “extension” is adopted from Harris and Campbell (1995; see also Campbell 2001a: 142–3).⁷ While these authors emphasize the syntactic

manifestations of this mechanism, we are confined here to one of its pragmatic manifestations: we will assume that extension obtains when a linguistic item can be used in new contexts where it could not be used previously.⁸

Once a form has acquired a new grammatical meaning, it tends to become increasingly divergent: it loses in categorial properties characteristic of its source uses, hence it undergoes decategorialization, and it tends to be used more frequently and in more contexts, to become more predictable in its text occurrence and, consequently, it tends to lose in phonetic substance, hence to undergo erosion. Thus, to the extent that extension, decategorialization, and erosion are components of a grammaticalization process, they presuppose desemanticization⁹ (cf. Haspelmath 1999: 1062). In the early stages of grammaticalization there may be a shift from less to more grammatical meaning although there are as yet no noticeable pragmatic, morphosyntactic, or phonetic changes associated with that shift (for examples, see below).

The following example from Swahili illustrates the effect of these mechanisms. Like many other languages (see Bybee et al. 1991), Swahili has grammaticalized a verb of volition to a future tense marker. Example (2a) illustrates the lexical use of the verb *-taka* 'want,' while (2b) illustrates its use as a future tense marker in relative clauses. In main clauses, the future marker was reduced to *-ta-*, cf. (2c). Desemanticization had the effect that the lexical meaning of the verb was "bleached out." Originally a lexical verb requiring typically human subject referents, its use was extended to contexts involving inanimate subjects (extension). In accordance with its use as a tense marker, *-taka* underwent decategorialization: it lost its status as an independent word and most other verbal properties and became a prefix of the main verb. Finally, *-taka* underwent erosion, being phonologically reduced to *-ta-* in main clauses (but retaining its original full form in relative clauses; see above):

(2) Swahili (Bantu, Niger-Congo):

- a. a- taka ku- ja
C1:PRES¹⁰- want INF- come
"He wants to come"
- b. a- taka- ye ku- ja
C1- FUT- C1:REL infinitive- come
"he who will come"
- c. a- ta- ku- ja
C1- FUT- INF- come
"He will come"

As noted above, there are gains deriving from the use of an item in new contexts that can offset losses of properties it may undergo. Moreover, grammaticalization requires specific contexts to take place and it therefore has been described as a product of pragmatic inferencing, pragmatic enrichment, strengthening, or conversational implicatures (Hopper and Traugott 1993: 163–77), or, as we will say, context-induced reinterpretation (see section 5).

As we will see below (sections 5 and 6), the framework described here has a number of implications for the development and structure of grammatical categories, and a number of models and descriptive devices have been proposed to deal with these implications.

3 Problems

Work on grammaticalization has been the subject of a number of critical discussions. Some authors expressed dissatisfaction with the classical definition proposed by Kuryłowicz (1965), proposing a more extensive use of the term. For example, Traugott (this volume) proposes to define grammaticalization “as the development of constructions [...] via discourse practices into more grammatical material.” As we observed in the introduction to this chapter, the development of grammatical items is shaped by the constructions in which these items occur; nevertheless, many grammaticalization processes that have been identified so far have been described largely without reference to constructions. Conversely there are no convincing examples so far to suggest that instances of grammaticalization processes can be identified exclusively in terms of constructions without referring to the form-meaning items involved in the process.

While there is now a wealth of publications on grammaticalization, extending from articles to books and contributions to handbooks on language structure and language change, in more recent years there has been massive criticism of grammaticalization theory (see especially Newmeyer 1998; Campbell 2001a; Campbell and Janda 2001; Janda 2001; Norde 2001). In this work, a number of weaknesses and inconsistencies found in previous analyses of grammaticalization are pointed out, and attention is drawn to areas of research that have been neglected or ignored in earlier work. In the present section, the main points of criticism are examined. It goes without saying that in a concise treatment like the present one it is not possible to do justice to all the problems that have been raised and all the views that have been expressed. We will therefore be confined to a few claims that challenge cornerstones of grammaticalization theory. Such claims are:

- i Not all instances of grammatical change are due to grammaticalization.
- ii Grammaticalization is not unidirectional.
- iii Grammaticalization is not a distinct process.
- iv “Grammaticalization theory” is not a theory.

With regard to (i), more recent research has demonstrated that grammatical change involves factors that are not covered by grammaticalization theory (see especially Newmeyer 1998; Campbell 2001a; Janda 2001; Joseph 2001a; Norde 2001), and future work will have to deal with these factors in more detail. Most of this research is concerned with the latest stages of grammaticalization,

typically (though not exclusively) with stages where grammatical forms have attained affixal status. What is required now is a comparative analysis to arrive at a more general understanding of the nature of these factors.

With regard to (ii), doubts have been raised as to whether grammaticalization truly is a unidirectional process, and a number of examples contradicting the unidirectionality hypothesis have been identified (see especially Joseph and Janda 1988; Campbell 1991, 2001a; Ramat 1992; Frajzyngier 1996; Janda 2001; Joseph 2001a; Norde 2001; and most of all, Newmeyer 1998: 260ff). However, first, as acknowledged by most of these scholars,¹¹ such cases are few compared to the large number of examples that confirm the hypothesis (cf. Joseph and Janda 1988: 198–200; Harris and Campbell 1995: 338; Newmeyer 1998: 275–6, 278; Haspelmath 1999). More importantly, however, no instances of “complete reversals of grammaticalization” have been discovered so far (cf. Newmeyer 1998: 263; Norde 2001; Janda 2001: 294–5). For example, the Old English noun *lic* ‘body’ has been grammaticalized to a denominal adjective suffix *-ly* in Modern English (Joseph 2001: 164), but it is highly unlikely that *-ly* will ever return to its former use, regaining the semantic meaning ‘body,’ morphosyntactic properties of a noun (such as having argument status and taking modifiers and the plural inflection), and regaining the full phonetic substance it once had.

Second, most of the counterexamples that have been identified can be described as being “idiosyncratic”¹² in the sense that they do not allow for cross-linguistic generalizations on the directionality in the rise and development of grammatical categories. For example, it has been observed that a case inflection, such as a genitive case suffix, may assume clitic status. Such a development can be said to be idiosyncratic, both language internally and cross-linguistically: language internally because it involves isolated instances within a given language, that is, there appears to be no general pattern whereby whole paradigms of case affixes turn into clitics; and cross-linguistically in that there does not seem to be a general directionality to the effect that, for example, genitive case suffixes regularly become clitics in many different languages.

Third, exceptional cases can frequently be accounted for with reference to alternative communicative forces, relating to the social, psychological, and cultural conditions shaping language use. Hypercorrection appears to be such a force (cf. Janda 2001). Another not uncommon force can be seen in euphemistic language use. For example, one common way in which concrete/lexical meanings give rise to more abstract/grammatical categories involves the grammaticalization of terms for body parts to markers of spatial orientation, whereby, for instance, a body part noun ‘back’ is grammaticalized to a spatial marker ‘behind’ or ‘in back of’ (see section 8).¹³ There are, however, some body parts, mostly (but not exclusively) body parts referring to sexual organs, that tend to be avoided in many social contexts and instead be denoted by spatial concepts (e.g., ‘(the thing) in front’, ‘(the one) below’). In a number of languages this has led to a reversal of grammaticalization, in that a term for deictic spatial orientation came to be conventionalized to a body part term. A similar motivation but a different result appears to have induced the change

from the German modal auxiliary *müssen* 'to have to' a full verb ('answer a call of nature'; Janda 2001: 313). Another factor can be seen in the particular sociocultural setting in which grammaticalization occurs (see Burridge 1995 for an example of a modal auxiliary that is "upgraded" to a lexical verb in Pennsylvania German).

A different kind of force can be seen in what has been described as exaptation, whereby grammatical categories in their final stages may lose their functional distinctiveness but retain their morphological form and put it to new functional uses. One possible effect this may have is that inflectional affixes can be regrammaticalized to derivational elements (Lass 1990; Norde 2001: 244ff).

Fourth, a possible alternative factor can be seen in situations of extreme language contact. In some creoles, for example, locative adverbs of the lexifier language (e.g., English) have been reinterpreted as verbs of state (e.g., Sranan). Such a process would seem to be at variance with observations commonly made in grammaticalization studies according to which open-class items such as verbs may assume the function of closed-class items such as adverbs, while the opposite does not normally happen; conceivably, this change can be linked to the special circumstances surrounding the growth of creoles (see Plag 2002).

With regard to (iii) it has been argued that grammaticalization is not a distinct process since the main mechanisms characterizing it – that is, desemanticization, extension, decategorialization, and erosion (see section 2) – can be observed to be also at work in other kinds of linguistic change (Newmeyer 1998: 248ff; Campbell 2001a; Janda 2001). There are a couple of reasons why such a position does not seem to be justified. First, the main task of grammaticalization theory is to provide explanations of why grammatical forms arise and develop, and it is these four mechanisms that have been found to be material to achieving such explanations. Thus, irrespective of how one wishes to define a "distinct process," these mechanisms and the way they are interrelated are part of one and the same explanatory framework (see also section 4).

Second, grammaticalization, as conceived here, is above all a semantic process. Desemanticization results from the use of forms for concrete meanings that are reinterpreted in specific contexts as more abstract, grammatical meanings. Having acquired grammatical meanings, these forms tend to become increasingly divergent from their old uses: they are used in new contexts (extension); lose in categorial properties characteristic of their old uses, hence undergo decategorialization; and tend to be used more frequently, become more predictable in their occurrence, and, consequently, lose in phonetic substance. Thus, the four mechanisms are not independent of one another; rather, desemanticization precedes and is immediately responsible for decategorialization and erosion (see section 2). For example, in many languages, prepositions unambiguously serving a grammatical function still have morphosyntactic properties of their earlier uses as adverbial phrases (cf. English *in spite of*, *in front of*, *with respect to*, etc.), and tense or aspect auxiliaries may still behave morphosyntactically to some extent like lexical verbs although they have lost their lexical semantics and serve exclusively as functional categories (cf. English *be going to*, *used to*,

keep (doing), etc.). To conclude, there is evidence to suggest that grammaticalization can be defined as a distinct process, leading to the rise and development of new grammatical forms.

Finally, with regard to (iv), it has been observed that “grammaticalization theory” is not a theory (see especially Newmeyer 1998; Campbell 2001a). For most students of grammaticalization this question is not, and has never been, an issue, since their concern is simply with describing grammatical change and the implication it has for a better understanding of language use; whether their work deserves or needs to be elevated to the status of a theory is not considered by them to be of major moment. Nevertheless, as we argued in section 2, there is something that can be called a theory of grammaticalization.

4 The Greek *θa*-Future

That “there is no process of grammaticalization” has been argued for in particular by Brian Joseph (2001a: 178–83), using among others the history of the Greek *θa*-future as an example. It may therefore be of help to take this example as a test case for our claim that grammaticalization is a distinct process.¹⁴

In a highly simplified form, the grammaticalization process involved three main stages, illustrated in (3). The initial stage is characteristic of Classical and early post-Classical Greek, where the verb of volition *thélo*: ‘want’ occurred as a main (lexical) verb with an infinitival complement, cf. (3a). This structure continues in a modified form into present-day Greek; at the same time, however, it also developed into another structure, illustrated in (3b), whereby the volitional (lexical) main verb underwent “semantic shift” (i.e., desemanticization) to acquire “a more auxiliary-like and grammatical future meaning (Joseph 2001a: 180).¹⁵ After a series of developments, including regular sound change, “reanalysis,” and analogical generalization of sandhi variants, the Modern Greek future emerged, where the erstwhile volitional verb, conventionalized in its third person singular form *thélei*, survives as a verbal prefix *θa* (though written separately from the main verb), while the erstwhile infinitival complement acquires the role of the main verb, inflected for person, cf. (3c):

(3) Greek (Joseph 2001: 178–83, this volume):

- a. *thélo*: *gráphein*.
want: 1SG write:INF
“I want to write”
- b. *thélo*: *gráphein*.
1SG write:INF
“I will write”
- c. *θa* *yráfo*.
FUT write:1SG
“I’ll be writing”

It would seem that we are dealing with a process that is identical with the one sketched for Swahili in (2) with reference to the following characteristics:

- i There is a structure ['want' + complement] which consists of a volitional verb taking an infinitival complement.
- ii The volitional verb undergoes desemanticization, losing its lexical semantics and becoming a future marker.
- iii The volitional verb undergoes decategorialization: it loses its verbal properties, it is fixed positionally and can no longer be inverted, and it can no longer support clitics or affixes.
- iv Furthermore, the volitional verb loses its independent status and ends up as a verbal prefix.
- v The volitional verb undergoes erosion: originally a disyllabic verb, it turns into a monosyllabic grammatical marker and is "deaccented," that is, it loses the ability to receive stress.¹⁶

Greek and Swahili (or the English *will*-future, for that matter) are but a few out of a large number of cases where a volitional verb 'want' was grammaticalized to a future tense marker (for more examples, see Bybee et al. 1991). To conclude, the Greek *θα*-future is a canonical instance of a grammaticalization process. That we are dealing with a distinct process is suggested, for example, by the fact that desemanticization preceded and was responsible for extension, decategorialization, and erosion (see Joseph 2001a: 183, this volume).

It goes without saying that this account is confined to a general outline of the process, in that it ignores many of the idiosyncractic developments accompanying the rise of the Greek *θα*-future, meticulously described by Joseph (2001a); nevertheless, it would seem to provide answers to questions that cannot be answered satisfactorily in any other theoretical framework that we are aware of. The following questions are examples (cf. section 2): (i) Why did this process take place in the first place? (ii) Why did it involve the same lexical verb ('want') and the same structural characteristics as observed in Swahili and many other languages? (iii) Why did it necessarily lead from lexical verb to tense prefix; that is, why is it unlikely that the process could have proceeded in the opposite direction from verbal prefix to lexical verb?

The present example may also be of help in solving another problem that some critics have with grammaticalization theory, namely that this theory leads to "vicious circularity" in that "a reconstruction initially justified by invoking a certain principle (grammaticalization) cannot later be argued to provide independent confirmation for that same principle" (Janda 2001: 271; see also Newmeyer 1998). This argument is relevant in particular to languages where we do not have earlier written documents, that is, where the reconstruction of a process of grammaticalization has to rely exclusively on synchronic evidence. We will assume that Swahili belongs in this category (ignoring the fact that the language in fact has earlier documents, written in Arabic). On the basis of historical evidence it is possible to observe that the Greek *θα*-future and the

English *will*-future developed along the same general lines:¹⁷ (i) a volitional verb serving as the main verb was grammaticalized to a future tense marker, with the erstwhile verbal complement assuming the role of the main verb; (ii) this process led to decategorialization (loss of verbal status) and erosion (reduction of form, loss of stress/accents; cf. English: *will* > 'll).

That our reconstruction of the Swahili *-ta*-future is correct is also suggested by language-internal evidence. As we observed in our Swahili example in section 2, the future tense marker retained its full form *-taka-* in relative clauses. Not uncommonly, lexical properties are lost in main clauses but may survive in subordinate clauses. The English *will*-future has retained properties of the erstwhile lexical verb *will* in specific contexts involving subordinate clauses, cf. *Do as you will*, where *will* underwent neither desemantization nor (optional) erosion. To conclude, without having any historical evidence, and without having to invoke any principle, it would seem justified to hypothesize that the same general process to be observed in Greek and English must have occurred in Swahili.

5 Conceptual Transfer versus Context-Induced Reinterpretation

The process whereby linguistic forms expressing concrete human experiences come to acquire less concrete, grammatical, functions has been described in a number of different ways. One line of research highlights the cognitive foundations of the process; it is based on what may be called the *transfer model*. Underlying the process, it is argued, there are patterns of conceptual transfer leading from concrete to less concrete domains of human experience. For example, as noted in section 3, the concrete body part 'back' has yielded more abstract locative adpositions and/or adverbials 'back, in back of' in many languages across the world, and verbs expressing physical motion ('go to,' 'come to') or volition ('want') have given rise to grammatical markers for future tense in languages that can be assumed to be neither genetically nor areally interrelated. Furthermore, concepts relating to the domain of space, such as demonstrative attributes, are commonly employed to express grammatical functions within the domain of text (see Frajzyngier 1991), for example, by turning into definite articles and relative clause markers. Such processes have been described as being metaphorical in nature, involving a transfer from concrete domains of human experience (physical objects and physical motion, respectively) to more abstract domains of spatial, temporal, textual, and other relations. According to Heine et al. (1991: 48ff), a prominent pattern of metaphorical transfer underlying many grammaticalization processes has the structure of an ontological domain shift as described in (4) (where domains to the left of the arrow are less abstract than domains to the right):

(4) PERSON > OBJECT > ACTIVITY > SPACE > TIME > QUALITY

Such transfers can be, and have been, described as metaphorical processes, for the following reasons: first, they involve a transfer from one domain of human conceptualization to another, for example, from the domain of the human body to that of spatial relations, or from physical actions to that of temporal or aspectual concepts. Second, metaphor is based on predications that, if taken literally, are false. For example, a predication on physical motion that actually denotes future tense instead of physical motion can be said to be literally false (cf. *Peter is going to come soon*). These are not the only criteria that have been used to define grammaticalization as a metaphorical process (for additional parameters, see Claudi and Heine 1986; Heine et al. 1991; Sweetser 1990; Heine 1997b).

Another line of research emphasizes the pragmatic component of the process, whereby grammaticalization (i) requires appropriate contexts to take place, (ii) subsequently leads to an increase in contexts where the grammaticalized item is used and, consequently, (iii) leads to an increase in the frequency of use of that item (cf. Bybee, this volume). We will refer to approaches highlighting this component as using a *context model*. Key notions relating to this model are context-induced reinterpretation, pragmatic inferencing, invited inference, conversational implicature, metonymy, and the like (cf. Traugott and König 1991; see also Dahl 1985: 11). Describing the development from a motion verb 'go to' to a future tense marker as metaphorical, it is argued in this tradition, highlights epiphenomenal properties of the process; what characterizes this development is a gradual extension where each context constitutes a new locus of change. Accordingly, the development from lexical verb to tense marker, or from body part noun to locative adposition, involves thousands of different contexts and centuries to be conventionalized.

Both the transfer model and the context model capture significant properties of grammaticalization, and both are required to understand why grammatical categories arise. Consider the following example: the German item *während* 'during, while' is a temporal conjunction in (5a), while in (5b) it may be interpreted as either a temporal (i) or a concessive conjunction (ii). In (5c), a temporal interpretation can be ruled out, and *während* functions exclusively as a concessive subordinator:

(5) German:

- a. Während er vor dem Fernseher sitzt, trinkt er Kaffee
 while he in:front to:the TV:set sits drinks he coffee
 "While he is watching TV, he is drinking coffee"
- b. Während sie ihn um Hilfe bittet, bleibt er vor dem
 while she him for help asks remains he in:front to:the
 Fernseher sitzen
 TV:set sit
 - (i) "While she asks him for help, he remains seated in front of the TV set"
 - (ii) "Although she asks him for help, he remains seated in front of the TV set"

- c. Während sie gestern noch krank war, kann sie heute schon
 while she yesterday still sick was can she today already
 wieder lachen
 again laugh
 "Although yesterday she was still sick, today she can laugh already"

We are dealing here with a common grammaticalization process according to which temporal markers are grammaticalized to conditional, causal, adversative, or concessive conjunctions introducing adverbial clauses (for another example involving English *since*, see Hopper and Traugott 1993). By using a transfer model one might argue that this is an instance of a process whereby concepts of the domain of time (cf. (5a)) are transferred to another domain relating to "logical" relations between clausal propositions (cf. (5c)). Proponents of a context model, on the other hand, would claim that there is no leap from one domain to another, rather, there is a gradual transition from temporal to concessive uses of *während*, involving, and being triggered by, intermediate contexts such as the one exemplified in (5b), which allow for both a temporal and a concessive interpretation (= the overlap model; cf. section 2, see also example (6) below). On account of such observations, Heine et al. (1991: 113) propose what they call the metonymic-metaphorical model of grammaticalization, which treats both the transfer and the context models as integral parts of the one and the same overall device.

6 Structural Properties

The framework described in section 2, especially the four mechanisms distinguished there, have a number of implications for the linguistic structures arising from grammaticalization. For example, Lehmann (1985) proposes the following concomitants of the process (with the exception of (iii), which concerns erosion, all these factors are effects of decategorialization):

- i paradigmization, that is, the tendency for grammaticalized forms to be arranged into paradigms;
- ii obligatorification, the tendency for optional forms to become used obligatorily;
- iii condensation, the shortening of forms;
- iv coalescence, the collapsing together of adjacent forms;
- v fixation, whereby free linear ordering becomes fixed.

Another effect of these mechanisms is that linguistic items belonging to open-class paradigms, such as nouns or verbs, turn into closed-class items, such as adverbs, adpositions, conjunctions, inflections, etc. Finally, these mechanisms have a number of more general effects, the most salient of which are described

by Hopper (1991) in terms of a catalog of principles of grammaticalization, which are:

- i layering, whereby older layers of language use are not necessarily discarded when new layers emerge, but may remain to coexist and interact with the newer layers;
- ii divergence. Divergence (or split; see Heine and Reh 1984: 57) results when a form undergoes grammaticalization and the original form continues to be used as an autonomous element so that the grammaticalized and the ungrammaticalized forms coexist side by side;
- iii specialization. As grammaticalization proceeds, the variety of formal choices narrows and an ever-smaller range of forms assumes a more general (grammatical) meaning;
- iv persistence. Some of the traces of earlier meanings of an item undergoing grammaticalization are likely to survive in the form of the grammatical distribution of the item concerned;
- v decategorialization (see section 2).

For further structural properties involved in grammaticalization, see Hopper and Traugott (1993: 113ff).

The development from less grammatical to more grammatical forms has been described as a continuous process, and various notions have been proposed to describe the structure of linguistic forms undergoing grammaticalization. To this end, Hopper and Traugott use the term “cline”:¹⁸

For example, a lexical noun like *back* that expresses a body part comes to stand for a spatial relationship in *in/at the back of* and is susceptible to becoming an adverb, and perhaps eventually a preposition and even a case affix. Forms comparable to *back of (the house)* in English recur all over the world in different languages. The progression from lexical noun, to relational phrase, to adverb and preposition, and perhaps even to a case affix, is an example of what we mean by a cline. (Hopper and Traugott 1993: 6)

Bybee et al. (1994: 14ff) and Bisang (1996), respectively, use the terms “path” and “pathway” instead, while Heine (1992, 1993) proposes the term “grammaticalization chain,” which is characterized in the following way: (i) it can be interpreted alternatively as a diachronic or a synchronic structure; (ii) it forms a linear structure where one end of the chain is both older and less grammaticalized, while the other end is younger and more strongly grammaticalized; (iii) it can be described as a linearly structured family resemblance category (Heine 1993: 53). The main reason for using the term “chain” rather than “cline” is that grammatical change exhibits an overlapping structure that is described by Heine (1993: 48–53) in terms of an overlap model (see section 2). According to this model, sketched in (6), the development of grammatical forms does not lead straight from the source meaning (or form) A to the target meaning (or

form) B but invariably involves an intermediate stage where A and B coexist side by side, thereby creating a situation of ambiguity (see (5b) for an example):

(6) $A > A, B > B$

Example (7) illustrates this model. It involves the grammaticalization of the Swahili verb of volition *-taka* 'want' to a marker of the proximative aspect ('be about to,' 'be on the verge of'; Kuteva 1998; Romaine 1999). (7a) is an instance of the lexical source meaning (A) of the verb. The overlap situation arises in contexts where a human subject referent cannot really be assumed to 'want' what is described by the relevant predication; such contexts involve verbs like 'die,' 'fall down,' or 'break (one's leg).' The meaning arising in such contexts is that of a proximative aspect ('be about to'); still, an interpretation in terms of volition is possible. Hence, (7b) is an instance of the overlap stage (A,B), also referred to as the bridging stage, where the utterance can be interpreted with reference to both the source meaning (A) and the target meaning (B) (= optional desemanticization). A clear instance of (B) is found in examples like (7c), where instead of a human referent there is an inanimate referent: In such contexts (= extension), the source meaning 'want' can be ruled out¹⁹ – with the result that we are now dealing with an aspectual marker:

(7) Swahili (Bantu, Niger-Congo):

- a. A- na- taka ku- ni- ita
C1- PRES- want INF- me- call
"He wants to call me"
- b. A- na- taka ku- fa
C1- PRES- want/PROX INF- die
i "He wants to die"
ii "He is about to die"
- c. M- ti u- na- taka ku- anguka
C3- tree C3- PRES- PROX INF- fall
"The tree is about to fall"

The presence of such overlap stages suggests that grammaticalization chains cannot be described appropriately in terms of discrete categorization (but see Newmeyer 1998).

It may happen that one and the same source form gives rise to different grammaticalization clines or chains and, hence, to more than one grammatical category. The Swahili examples discussed above are suggestive of such a situation. On the one hand, the verb *-taka* 'want' has become a future tense marker (*-ta-*; see example (2)); on the other hand, it has developed into a proximative aspect marker (example (7)). Such cases, called polygrammaticalization (Craig 1991), are cross-linguistically quite common; a worldwide survey of grammaticalization processes shows, for example, that some lexical items, such as verbs

meaning 'come,' 'get,' 'go,' or 'say,' have given rise to seven or even more different kinds of grammatical categories (Heine and Kuteva 2002).

Conversely, one and the same grammatical function may be derived from two or more different source forms. Future tense markers, for example, can be traced back to a number of different lexical forms, in particular to verbs of motion ('go to,' 'come to') or verbs of volition ('want,' 'desire'). English offers an example: it has one future tense category (*be going to*) derived from a motion verb and another one (*will*) derived from a volitional verb.

Another issue concerns the semantic development in the process of grammaticalization (desemanticization), where three main models have been proposed. According to the most prominent model, the development entails a loss in semantic content of the item concerned; nouns and verbs lose most or all of their lexical meaning when they are pressed into service for the expression of grammatical functions, demonstratives lose their deictic meaning when they turn into definite articles or third person pronouns, and the quantifying component of a numeral for 'one' is bleached out once it is grammaticalized as an indefinite article, etc. Adherents of the "bleaching model" argue that all, or at least most, instances of grammaticalization can be described in terms of semantic change as sketched in (8), whereby one component of meaning (a) is lost while the second component (b) is retained:

(8) $ab > b$

Other students of grammaticalization emphasize that in addition to semantic loss there are also gains. For example, when a verb of motion 'go to' gives rise to the development of a future tense marker then the semantics of physical motion is bleached out. At the same time, however, the semantics of the more abstract domain of tense is added, whereby the erstwhile verb of motion acquires a new sense of prediction or futurity within the cognitive space of tense. In a similar fashion, the development from demonstrative modifier to definite article does not only involve a loss of deictic content, but may also be described as leading to a gain of discourse-referential properties within the domain of text. Accordingly, adherents of this model (Traugott 1980: 47, 1988: 49; Sweetser 1990) argue that while one component of meaning (a) gets lost, another component (c) is added, which means that the loss-and-gain model, as it has been called (Heine et al. 1991: 110), has a structure as sketched in (9):

(9) $ab > bc$

A third model, called the implicature model (Heine 1993), is based on the assumption that grammaticalization may not only involve the addition of a new component but also the loss of the original component; cf. (10). A paradigm case can be seen in the development of the early French negation marker *ne*, which was strengthened by the noun *pas* 'step' (or a few other nouns), thus giving rise to a discontinuous marker *ne . . . pas* in modern French. In some

modern uses, *ne* is dropped so that *pas* can be interpreted as having led to a development from a noun 'step' to a negation marker, where the two meanings do not seem to have any component in common:

(10) $ab > bc > cd$

The three models tend to be portrayed as being mutually exclusive, but as a matter of fact they are not; rather, the bleaching model can be said to be contained in the loss-and-gain model, which again is contained in the implicature model, as is suggested by (11).

(11) $ab > b$ Bleaching model
 $ab > bc$ Loss-and-gain model
 $ab > bc > cd$ Implicature model

While the implicature model offers the most comprehensive basis for understanding semantic change in the development of grammatical forms, there are many instances of grammaticalization that suggest that the bleaching model is the most basic one, which is the *sine qua non* for grammaticalization to happen.

7 Terminological Issues

A plethora of terminological distinctions has been proposed to describe grammaticalization.²⁰ Some of these distinctions have turned out to be useful while others have become the subject of controversy, to the extent that we decided not to use them in the present chapter. The latter applies, for example, to the term "reanalysis." Since grammaticalization leads to a change from one meaningful unit to another, or from one structure to another, it has been described by some as a process that necessarily involves reanalysis, while others insist that the two notions should be separated (cf. Hopper and Traugott 1993: 48–56; Newmeyer 1998; Haspelmath 1998; Campbell 2001a: 143–51). There are four conceivable positions on the relation between these two notions, namely:

- i The two are coextensive, that is, all instances of grammaticalization are instances of reanalysis and all instances of reanalysis are also instances of grammaticalization.
- ii There is an inclusion relation, in that all instances of grammaticalization involve reanalysis but not all instances of reanalysis involve grammaticalization.
- iii The two are disjoint classes of phenomena, but some instances of grammaticalization are also instances of reanalysis, and vice versa.
- iv The two are mutually exclusive phenomena.

To our knowledge, neither (i) nor (iv) has ever been maintained by students of the subject matter. (ii) is the position taken in particular by Hopper and Traugott (1993: 61–2), Newmeyer (1998), and Campbell (2001a), while (iii) is maintained, for example, by Heine and Reh (1984) and Haspelmath (1998). Since these different uses of the term “reanalysis” have given rise to a number of (as we think, unnecessary) misunderstandings, we propose to avoid it in future discussions on grammaticalization, in spite of the usefulness it has, for example, for describing syntactic change (see especially Harris and Campbell 1995). It would seem that these misunderstandings are to some extent due to differences in theoretical orientation. For example, for Campbell (2001a: 151) “reanalysis (also sometimes extension) is the determining mechanism that explains grammaticalization and without appeal to these mechanisms, grammaticalization has no explanatory power of its own.” This theoretical assumption is not shared by some students of grammaticalization, for whom syntax does not provide an explanatory parameter; for them, syntax itself is in need of explanation, and grammaticalization provides one parameter for explaining syntax (see, e.g., our Teso example in section 8). According to the latter view, which is also held in this chapter (see section 2), grammaticalization is explained more profitably with reference to the functions that language serves, and the term (syntactic) reanalysis is not viewed as having any explanatory power in grammaticalization studies.²¹

Like reanalysis, the term “analogy” has experienced a wide range of uses, referring to sometimes disparate phenomena of grammatical change. Meillet (1912) treated analogy and grammaticalization as mutually exclusive; others again (Hopper and Traugott 1993: 61–2) argue that grammaticalization does not occur without analogy.²² As we see it, both are right; analogy is a ubiquitous strategy that can be invoked for many different phenomena, to the extent that its use is sometimes not very helpful for describing and/or understanding the specifics of grammaticalization.

Much the same applies to the term “degrammaticalization”: it has received contrasting uses, and been employed, for example, to refer to mirror image reversals of grammaticalization,²³ or to a process whereby a more grammatical item assumes a less grammatical status (cf. Lehmann 1982: 19–20), or to describe the final phase of grammaticalization where an item loses its grammatical status, or else where a grammatical item loses its meaning or function (see especially Norde 2001: 236–7 for a discussion). In view of such a confusing variety of definitions, “degrammaticalization” is not further used in this chapter.

Grammaticalization begins with concrete, lexical forms and constructions and ideally ends in zero (see example (1), section 1); that is, grammatical forms increasingly lose in semantic, morphosyntactic, and phonetic content and, in the end, they may be replaced by new forms. Grammaticalization has therefore been described as a cyclical process (Givón 1979; Heine and Reh 1984; Croft 1990: 230). In fact, cyclicity can frequently be observed, but it is neither a necessary nor a sufficient property of grammaticalization: there are many examples suggesting that grammatical forms which lose their functions and/or phonetic

substance are not necessarily replaced by new forms. Hence, cyclicity is not used as a central term of grammaticalization theory.

8 Some Findings

Research carried out in the course of the past three decades has produced a number of generalizations on the evolution of grammatical categories. The following is a brief summary of the kinds of findings that have been made; the reader is referred to the publications cited for exemplification as well as for further grammaticalizations (see, e.g., Heine and Kuteva 2002).

Within the domain of tense, aspect, and modality, the following is a catalog of commonly observed processes. In more general terms, these processes suggest that verbal aspect categories can give rise to tense categories, or tense categories can be used for the expression of epistemic modality, while processes in the opposite direction are unlikely to happen:

- i Present tense and imperfective markers are frequently derived from progressive markers.
- ii The primary source of future tenses is provided by motion schemas (*X goes to/comes to Y*) and volition schemas (*X wants Y*).
- iii Progressives are most commonly derived from location (*X is at Y*), action (*X does Y*), and companion schemas (*X is with Y*).
- iv Perfect (anterior) markers tend to be derived from resultative or completive markers.
- v Completive markers again are perhaps most commonly derived from verbs meaning 'finish.'
- vi Iterative aspect markers tend to have verbs meaning 'turn' or 'return' as their lexical source.
- vii Markers for deontic (agent-oriented) modality commonly develop into markers for epistemic modality.
- viii Epistemic modality may also be expressed by means of future and past tense markers.

Within the nominal domain, developments such as the following can be observed in the languages of the world:

- ix Definite articles are almost invariably derived from demonstrative modifiers, and indefinite articles from numerals for 'one.'
- x Relative clause markers are also frequently derived from demonstratives, less commonly also from interrogative markers.

Another area of regular grammatical change is that of case marking, where generalizations such as the following have been made:

- xi Allative case markers are the source for a variety of case functions, including benefactive, dative, and purpose markers.
- xii Purpose markers may develop into infinitive forms or markers of cause.
- xiii Cause markers again can be derived from a variety of case forms, such as locative and temporal markers.
- xiv Accusative markers have dative case markers as one of their historical sources.
- xv Comitative markers are likely to give rise to instrumental case markers and coordinating conjunctions ('and').
- xvi Instrumental markers tend to acquire uses as manner markers.

As has been demonstrated in a number of studies, case markers are not functional primitives; rather, wherever there is historical evidence, they can be shown to ultimately go back to lexical items, most of all to terms for body parts, environmental landmarks, and process verbs. Thus, for locative case markers denoting concepts of deictic orientation, generalizations such as the following have been proposed:

- xvii Grammatical markers for FRONT ('in front,' 'ahead') tend to be derived from body part nouns for 'face,' 'eye,' less commonly also for 'breast' or 'head.'
- xviii Markers for BACK ('behind,' '(in) back (of)') are in most cases derived from body part nouns for 'back.'
- xix In the case of markers for DOWN ('below,' 'down,' 'under') the most likely lexical source are nouns meaning 'earth,' 'ground,' and the like, while body part nouns (e.g., 'foot,' 'buttocks,' etc.) are less commonly recruited for this purpose.
- xx Case markers also commonly give rise to markers of clause subordination, in that their function is extended from nominal to clausal participants.

Since the items undergoing grammaticalization are part of the constructions in which they are used, grammaticalization can also be held responsible for many kinds of syntactic changes. For example, if a verb for 'give' is grammaticalized to a benefactive or dative adposition, then this is likely to lead to a syntactic change from verb phrase (V + NP) to adverbial phrase (PREP + NP). In addition, it not uncommonly happens that the grammaticalization of a morphological item may result in the rise of a new word order arrangement. For example, in a number of Niger-Congo languages the introduction of new markings for verbal aspects has given rise to new periphrastic constructions which again appear to have triggered new word order patterns (Claudi 1993, 1994).

That word order change and other syntactic phenomena are frequently epiphenomenal products of such changes²⁴ can be illustrated with the following example from Teso, a Nilotic language spoken in eastern Uganda. Teso has verb-initial (VSO) basic word order, cf (12a); in negative clauses, however,

there is verb-medial (SVO) order, that is, the verb follows the subject but precedes the object, as illustrated in (12b). The VSO-order of (12a) illustrates the earlier pattern, while (12b) is suggestive of an innovation which can be explained in the following way: the negative marker *mam* is historically a verb **-mam* meaning ‘be absent, lack, not to be.’ Historically, (12b) consists of two clauses which can be reconstructed as in (12c), and the basic order of (12c) can be reconstructed as in (12d). Now, the erstwhile verb **-mam* was grammaticalized to a negation marker (desemanticization) and lost most of its verbal properties (deategorialization), such as the ability to inflect for person or tense-aspect, and it became an invariable particle. But the clausal syntax remained the same, that is, *mam* still occurs in clause-initial position followed by its erstwhile complement (*petero*), which was reinterpreted as the subject of the following clause. Thus, the structure sketched in (12d) was replaced by (12e). Since positive sentences like (12a) were not affected by this development, they retained the original VSO word order:

(12) Teso (Western Nilotic; Nilo-Saharan):

- a. ekoto petero ekinok
wants Peter dog
“Peter wants a dog”
- b. mam petero ekoto ekinok
NEG Peter wants dog
“Peter doesn’t want a dog”
- c. *e- mam petero ekoto ekinok
3- not:be Peter wants dog
“It is not Peter (who) wants a dog”
- d. *Verb + complement + verb + object
- e. NEG + subject + verb + object (Heine and Reh 1984: 185–6)

9 Historical Reconstruction

Grammaticalization has some attributes in common with orthodox methods of historical linguistics. Like the comparative method, it is based on the exploitation of regularities in the development of linguistic forms for reconstructing earlier states of language use. In the case of the comparative method, these regularities are manifested, for example, in sound correspondences; in the case of grammaticalization, they consist in the regular behavior underlying desemanticization, extension, deategorialization, and erosion.

But unlike the comparative method, work on grammaticalization is not confined to comparisons across languages or dialects; it may also concern language-internal analysis. In this respect, grammaticalization theory resembles internal reconstruction. Compared to the latter, however, which concentrates on unproductive/irregular alternations, grammaticalization studies are not

restricted in such a way: they deal in much the same way with regular and with irregular patterns, and they are concerned with morphological, syntactic, semantic, and pragmatic problems; it is only in the domain of phonology where they have not much to contribute. Their main contribution lies in the reconstruction of grammatical forms but, as we saw in section 8, it is also of help in analyzing syntactic change.

Semantic change constitutes a problem area in orthodox methods of historical linguistics; it is considered to be irregular, and Anttila concludes "that there are no exact rules for handling semantic change; the final factor here is necessarily the common sense and the experience of the individual scholar" (1989: 229). No wonder that semantics is not considered to be a priority area in the application of the comparative method. Findings on grammaticalization provide a systematic access to semantic change, at least as far as grammatical meaning is concerned.

While grammaticalization theory constitutes an enrichment of historical linguistics, since it offers an additional instrument for diachronic reconstruction, it may at the same time challenge already existing reconstructions. Suppose there are a number of genetically related languages sharing the same typological property. For the historical linguist this fact may be, and has been, taken as evidence that that property can be traced back to the proto-language concerned. For example, a number of Indo-European languages have used the goal schema (*Y exists to/for X*) for predicative possession (*X has/owns Y*), that is, a construction where the verb is 'be, exist,' the possessee is encoded as the subject and the possessor as a dative complement. This fact has been taken as evidence to argue that the goal schema can be reconstructed back to Proto-Indo-European (cf. Meillet 1923; Löfstedt 1963; Isačenko 1974). Grammaticalization studies suggest that such a procedure needs to be reconsidered in light of the fact that the goal schema has not only been used in Indo-European languages but constitutes worldwide one of the common means of grammaticalizing expressions for predicative possession (Heine 1997b). Rather than being a characteristic of Proto-Indo-European, the goal schema may have evolved later, being used independently in various Indo-European languages.

In other cases, grammaticalization studies may contribute to revising or improving existing lexical reconstructions based on the comparative method. Two examples from the Bantu subfamily of Niger-Congo may illustrate this. For Proto-Bantu, the hypothetical ancestor of the 300-plus modern Bantu languages, a root **-dà* 'intestine(s),' 'abdomen,' 'inside' has been reconstructed. Since body parts provide the most common source for deictic location, and nouns for 'stomach' or 'bowels' are frequently grammaticalized to adverbial or adpositional markers for 'inside' (see Heine 1997b), there is reason to assume that 'inside' is a later development of the meanings 'intestine(s)' or 'abdomen' of Proto-Bantu **-dà*. That the development from body part noun to locative marker happened independently in many Bantu languages after the split-up of Proto-Bantu is suggested by observations in some modern Bantu languages (e.g., Tswana, Sotho), where there are reflexes of the body part meaning ('bowels') but no traces of a locative marker.

The second example illustrates the effect of several mechanisms of grammaticalization in the development of grammatical forms. There are two Proto-Bantu roots having a similar form: **-béédè* 'breast, udder' and **-bèdè* '(in) front.' Once again we are led to hypothesize that the locative meaning '(in) front' is historically derived from the body part meanings. This claim is based, first, on the observation that reflexes of **-bèdè* exhibit traces of decategorialization, in that they lack some of the nominal properties that reflexes of **-béédè* show. Second, **-bèdè* appears to have undergone erosion, in that it has a form that is phonologically reduced vis-à-vis the noun **-béédè*: the geminated vowel *éé* has been reduced to a short vowel, and the tonal contour high–low has been simplified to low–low.

On the other hand, there are some areas of reconstruction where the contribution of grammaticalization theory is severely limited. One such area concerns the dating of historical events. It is possible to establish relative chronologies of grammatical change, of the kind *X must have preceded Y in time*. For example, it is possible to establish that the body part meanings of the Bantu items just mentioned must have been there before the locative meanings arose. But beyond such observations, the potential of grammaticalization theory for dating historical events is limited. Similarly, grammaticalization theory has little to offer in the area of genetic classification or subclassification. With regard to the time depth of reconstruction, grammaticalization theory is similar in scope to the comparative method: both allow for empirically sound historical reconstructions when a time depth of a few centuries or a few millennia is involved, but reconstruction work becomes less reliable the more one goes back in time.

10 On Prediction

Grammaticalization theory is a field that is diachronic in the true sense: it not only allows for historical reconstructions but also makes it possible within limits to predict what is going to happen in the future, or else what is likely to exist in some unknown language (Heine 1995). For example, on the basis of the generalizations summarized in section 8 we may postulate at least weak predictions such as the following:²⁵

- i If in a given language a new definite article arises then it is likely to be derived from a demonstrative modifier.
- ii If a new indefinite article arises then most likely it will have a numeral 'one' as its source.
- iii If a new locative marker for BACK ('behind, (in) back (of)') is developed then the most probable source is a body part noun for 'back,' or, in more general terms, new terms for deictic spatial orientation are most likely to have body part terms as their conceptual source.
- iv If a new temporal marker (adverb, adposition, conjunction) evolves then it is likely to be derived from a locative marker.

While these are examples of predictions that appear to have a universal base, there are also conspicuous grammaticalizations that appear to be areally determined (Heine 1994a). For example, the body part ‘tooth’ provides a widespread source concept for the locative concept IN (‘inside,’ ‘in’) in Oceanic languages, while it is largely irrelevant in Africa, where one might predict that ‘belly/stomach’ (or ‘bowels’) is the most likely choice (Bowden 1992; Heine 1997b; cf. section 8 above).

It goes without saying that all these predictions are probabilistic in nature, and we concur with Campbell (2001a: 153) in that “strong claims for the predictive power of grammaticalization are clearly exaggerated.” As was observed above, grammaticalization theory is not a theory of language change and, as has been aptly demonstrated in recent work (especially Harris and Campbell 1995; Newmeyer 1998; Joseph 2001a; Janda 2001), grammaticalization constitutes merely one of the factors that determine the history and future development of grammar.

ACKNOWLEDGMENT

We are grateful to Ulrike Claudi, Brian Joseph, and Elizabeth Traugott for valuable comments on an earlier version of this chapter, and to Fritz Newmeyer, even if the views expressed in this chapter differ in a number of ways from his.

NOTES

- 1 For a fairly comprehensive list of definitions that have been proposed for grammaticalization, see Campbell and Janda (2001).
- 2 Depending on which aspect of the process is concerned, students of the subject matter have referred to the process variously as evolution, development, chain of development, or simply as change. Note further that the term “process” has frequently been used in a more general sense, referring both to the process as a whole and to individual manifestations of it.
- 3 Some authors (especially Newmeyer 1998 and Campbell 2001a) have rightly pointed out that in previous works it has not been made sufficiently clear whether unidirectionality is an empirical hypothesis or an artifact of the definition of grammaticalization.
- 4 Presumably, this is a reformulation of Hodge’s (1970: 3) hypothesis “one man’s morphology was an earlier man’s syntax.”
- 5 In view of this and the preceding assumptions, claims such as the following (see also Newmeyer 1998) are hard to reconcile with what one commonly finds in works on grammaticalization: “it is a salient characteristic in most studies of grammaticalization that they are phrased in terms of implying that morphemes exist apart from mortal speakers [. . .]. That is, the emphasis is not on people but on morphemes” (Janda 2001: 283).

- That grammaticalization is motivated by human behavior and human aspirations has been pointed out in some way or other by all proponents of grammaticalization studies.
- 6 The fact that grammaticalization involves mechanisms relating to different components of language structure has been used to argue that grammaticalization theory cannot be defined as a distinct process (Newmeyer 1998; Campbell 2001a; Joseph 2001a; see section 2 above). We do not think that this is a valid argument. Many theories of language do exactly the same, combining such diverse phenomena as phonetics, syntax, and semantics within one theoretical framework. An entirely different catalog of mechanisms is proposed by Hopper and Traugott (1993: 61–2): “Reanalysis and analogy are the major mechanisms in language change. They do not define grammaticalization, nor are they coextensive with it, but grammaticalization does not occur without them.” Concerning reanalysis and analogy, see section 7.
 - 7 Harris and Campbell (1995: 3) define extension as “a change in the surface manifestation of a pattern [. . .] which does not involve immediate or intrinsic modification of underlying structure.”
 - 8 Instead of saying that extension changes “the syntax of a language by generalizing a rule” (Harris and Campbell 1995: 97), we will say that extension changes the use of a linguistic expression by adding one (or more) contexts in which that expression can be used.
 - 9 More research on the interaction between desemanticization and extension is required. Bybee et al. (1994: 6), for example, argue that the former (= semantic generalization in their terminology) correlates with the latter.
 - 10 The item *a-* in (2a) is a portmanteau morpheme consisting of the noun class 1 marker *a-* plus the tense marker *-a-*. Throughout this chapter, C1 = noun class 1, C3 = noun class 3, etc.
 - 11 For a possible exception, see Janda (2001).
 - 12 Note, however, that there are some more general principles that have been invoked to deal with counterexamples of grammaticalization. Perhaps the most important is analogy (see, e.g., Joseph 2001a: 173ff).
 - 13 Campbell (2001a: 129ff) rightly observes that the view expressed in some earlier studies that some counterexamples to unidirectionality involve lexicalization rather than grammaticalization can no longer be upheld.
 - 14 In the following treatment we are confined to the data presented by Joseph (2001a: 178–83); for further details see Tsangalidis (1999); see also Campbell (2001a: 114).
 - 15 It does not become entirely clear when this change occurred.
 - 16 The Swahili future marker *-ta-* lost the ability to be stressed in main clauses, but retained it in relative clauses, where the full form *-taka* survived (see section 2).
 - 17 For more details, see Bybee et al. (1991).
 - 18 The term “cline” had been proposed earlier by Halliday (1961: 249), who defines it as a “continuum carrying potentially infinite gradation” involving “a relation along a single dimension.”
 - 19 Unless there is some metaphorical and/or culture-specific conceptualization to the effect that inanimate participants are, or can be, presented as willful beings.

- 20 For example, roughly a dozen of different terms have been proposed to refer to the mechanism of desemantization.
- 21 We are ignoring here cases where syntactic change, or reanalysis, does not involve grammaticalization. A wide range of such cases is discussed in Harris and Campbell (1995).
- 22 Hopper and Traugott (1993: 56) observe that when Meillet was writing, there was a rather narrow, local interpretation of analogy.
- 23 Norde (2001: 260) observes that no real reversal of grammaticalization has been observed so far.
- 24 Not all instances of syntactic change, however, are necessarily also instances of grammaticalization; for examples see Harris and Campbell (1995).
- 25 It would seem that the account of predictability proposed by Campbell (2001a: 152–3) is not entirely in line with what has been observed earlier on this subject. It is correct that one lexical or grammatical form can be grammaticalized in different contexts to two or more different new forms (= polygrammaticalization), and conversely that, for example, a given grammatical function can have more than one lexical or functional sources. We doubt, however, whether this observation is sufficient to argue that grammaticalization theory lacks predictability. For example, demonstratives may give rise to a number of different grammatical markers (see Diessel 1999), including definite articles, and Harris and Campbell (1995: 341–2) consider the change demonstrative pronoun > definite article > case marker or gender-class marker “a likely candidate for a unidirectional sequence of changes” since no change in the opposite direction has been observed. On the basis of such generalizations we feel justified in formulating predictions such as (i) in section 10.

19 Mechanisms of Change in Grammaticization: The Role of Frequency

JOAN BYBEE

One of the most notable characteristics of grammatical morphemes (hereafter “grams”; see Bybee and Dahl 1989) and the constructions in which they occur is their extremely high text frequency as compared to typical lexical morphemes. Since grams commonly develop from lexical morphemes during the process of grammaticization, one striking feature of this process is a dramatic frequency increase. This increase comes about as a result of an increase in the number and types of contexts in which the gram is appropriate. Frequency is not just a result of grammaticization, it is also a primary contributor to the process, an active force in instigating the changes that occur in grammaticization. This chapter treats two topics: (i) the manner in which the extreme frequency increase occurs, which will be examined via a case study of *can* in Old and Middle English; and (ii) those mechanisms of change associated with grammaticization that are attributable in some way to this dramatic frequency increase, including phonological, morphosyntactic, and semantic change. A third important theme of this chapter echoes that found in Traugott (this volume): none of these changes can be studied except in the context of the construction in which the grammaticizing element occurs.

1 The Grammaticization of Constructions

The recent literature on grammaticization seems to agree that it is not enough to define grammaticization as the process by which a lexical item becomes a grammatical morpheme, but rather it is important to say that this process occurs in the context of a particular construction (see Heine and Traugott, both this volume). In fact, it may be more accurate to say that a construction with particular lexical items in it becomes grammaticized, instead of saying that a lexical item becomes grammaticized. For instance, several movement verbs appropriately fit into the following constructional schema of English:

- (1) [[movement verb + Progressive] + purpose clause (*to* + infinitive)]

E.g., *I am going to see the king*
I am traveling to see the king
I am riding to see the king

However, the only example of this construction that has grammaticized is the one with *go* in it. The particular example of this construction with *go* in it has undergone phonological, morphosyntactic, semantic, and pragmatic changes that have the effect of splitting the particular grammaticizing phrase off not only from other instances of *go* but also from other instances of this [movement verb + Progressive + purpose clause] construction.

2 The Role of Repetition

Also in the recent literature on grammaticization, we find extensive discussions of semantic change and its sources (see Heine et al. 1991; Traugott 1989; Bybee et al. 1994), but much less emphasis on the development of morphosyntactic and phonological properties of emerging grams. In an attempt to offer an integrated approach to the multiple changes that constitute grammaticization, I will focus in this chapter on the role that repetition plays in the various changes that a grammaticizing construction undergoes. The importance of repetition to grammaticization has been emphasized in Haiman's (1994) discussion of the parallels between the general cultural phenomenon of ritualization and the process of grammaticization in language, and in Boyland's (1996) examination of the effects of repetition on the cognitive representation of grammaticizing constructions. Building on these works, I will argue for a new definition of grammaticization, one which recognizes the crucial role of repetition in grammaticization and characterizes it as the process by which a frequently used sequence of words or morphemes becomes automated as a single processing unit.

Haiman (1994) makes a case for regarding the process of grammaticization as ritualization, citing the following aspects of ritualization, all of which are the result of repetition: *habituation* results from repetition and depletes a cultural object or practice of its force and often its original significance as well; repetition leads to the *automatization* of a sequence of units, and the reanalysis of the sequence as a single processing chunk, with formerly separate units losing their individual meaning; repetition also leads to the *reduction of form* through the weakening of the individual gestures comprising the act, and through the reorganization of a series of formerly separate gestures into one automated unit; and *emancipation* occurs as the original, more instrumental function of the practice gives way to a more symbolic function inferred from the context in which it occurs.

Applying these aspects of ritualization to the grammaticization process in particular, I will argue that frequent repetition plays an important role in the following changes that take place in grammaticization:

- i Frequency of use leads to weakening of semantic force by habituation – the process by which an organism ceases to respond at the same level to a repeated stimulus (section 4).
- ii Phonological changes of reduction and fusion of grammaticizing constructions are conditioned by their high frequency and their use in the portions of the utterance containing old or backgrounded information (section 5).
- iii Increased frequency conditions a greater autonomy for a construction, which means that the individual components of the construction (such as *go*, *to* or *-ing* in the *be going to* example of (1)) weaken or lose their association with other instances of the same item (as the phrase reduces to *gonna*) (section 6).
- iv The loss of semantic transparency accompanying the rift between the components of the grammaticizing construction and their lexical congeners allows the use of the phrase in new contexts with new pragmatic associations, leading to semantic change (section 7).
- v Autonomy of a frequent phrase makes it more entrenched in the language and often conditions the preservation of otherwise obsolete morphosyntactic characteristics (section 8).

Before moving to an expanded discussion of each of these aspects of grammaticization, I will discuss the two ways of counting frequency in section 3, and demonstrate in section 4, with a case study of the development of *can* in English, how a grammaticizing construction increases its frequency.

3 Type and Token Frequency

Two methods of counting frequency are relevant for linguistic studies: one method yields token frequency and the other type frequency. Token or text frequency is the frequency of occurrence of a unit, usually a word or morpheme, in running text. For instance, *broke* (the past tense of *break*) occurs 66 times per million in Francis and Kucera (1982), while the past tense verb *damaged* occurs 5 times in the same corpus. The token frequency of *broke* is much higher than that of *damaged*. We can also count the token frequency of a grammaticizing construction, such as *be going to*, by counting just those occurrences of *be going to* that are used with a following verb (rather than a noun).

Type frequency refers to the dictionary frequency of a particular pattern, such as a stress pattern, an affix, etc. For instance, English past tense is expressed in several different ways, but the expression with the highest type frequency is the suffix *-ed*, as in *damaged*, which occurs on thousands of verbs. The pattern

found in *broke* has a much lower type frequency, occurring with only a handful of verbs (depending upon how you count them: *spoke, wrote, rode, etc.*).

The notion of type frequency can also be applied to grammaticizing constructions by counting the different lexical items with which a construction can be used: for instance, when in Shakespeare's English *be going to* had its literal meaning of a subject traveling to a location in order to do something, the subject position could only be occupied by a noun phrase denoting an animate, mobile entity, and the verb following the phrase would have to be a dynamic verb. As the phrase grammaticized and changed its meaning the number of different types appropriate for subject position expanded to include non-animate and non-mobile entities and the verb position expanded to include a broader range of predicates (e.g., current usage allows *The tree is going to lose its leaves; I'm going to be ready at nine; etc.*). A grammaticizing phrase is thus said to increase in generality (Bybee 1985) as the contexts in which it is appropriate move from very specific to more general.

A much-noted property of grammaticizing constructions is this increase in type frequency of co-occurring lexical items. As a consequence, the token frequency of units such as *going to* or *gonna* also increases dramatically. As important as the increase in type frequency or generality is, it is the high token frequency of grammaticizing phrases which provides the triggering device for many of the changes that occur in the form and function of the grammaticizing construction. High token frequency triggers many changes because it affects the nature of the cognitive representations in ways that will be explained as we proceed. First, however, we turn to the issue of the increase in token frequency of grammaticizing constructions, using the English modal auxiliary *can* as a case study.

4 How Does Frequency Increase? A Case Study of *can*

4.1 Generalization of meaning

One of the earliest-mentioned mechanisms of semantic change in grammaticization is bleaching or generalization, the process by which specific features of meaning are lost, with an associated increase in the contexts in which the gram may be appropriately used (Meillet 1912; Lehmann 1982).¹ In fact, generalization seems to characterize the entire grammaticization continuum – we note that as the process unfolds, grams always become more general and more abstract in their meaning, more widely applicable and more frequently used.² The mechanism behind bleaching is habituation: a stimulus loses its impact if it occurs very frequently.

Grammaticizing expressions have inherent meaning derivable from the meanings of their component parts. It is this inherent meaning that is said to be

Table 19.1 Stages of development for *can*

Stage	Meaning	
Mental ability	Mental	enabling conditions exist in the agent
Ability	_____	enabling conditions exist in the agent
Root possibility	_____	enabling conditions exist _____

Table 19.2 Contexts of use of *can*

Stage	Subject	Main verbs
Mental ability	Human agents	Intellectual states and activities Communicating Skills
Ability	Human agents	All of the above Overt actions and activities
Root possibility	Human agents Passive subjects Inanimate subjects	All of the above

bleached as grammaticization proceeds. In some cases (though certainly not all), a neat diagram may be constructed showing which parts of the original meaning are lost along the way. For instance, Modern English *can*, derived from an Old English main verb, *cunnan* 'to know,' can be charted as going through the stages in table 19.1³ (cf. Bybee 1988 on *may*). At each stage, *can* is used in a wider range of contexts (table 19.2).

Ability and mental ability are self-explanatory; root possibility asserts that enabling conditions exist in general. They include the inherent abilities of the agent, but also factors in the external world that create enabling conditions. Examples follow:

(2) *Mental ability:*

Ful wys is he that kan hysselfen knowe!

"Completely wise is one who knows himself!" (B. Mk. 3329)⁴

(3) *Skill:*

Ther seen men who kan juste and who kan ryde

"Men are seen there who can (i.e., know how to) joust and who can ride"

(A. Kn. 2604)

- (4) *Ability*:
 But I wol passe as lightly as I kan
 “But I will pass by as lightly as I can” (B. NP. 4129)
- (5) *Root possibility*:
 Thou cannest not haue of Phocion a frende and a flaterer both to gether
 “You cannot (It is not possible to) have of Phocion both a friend and a flatterer both” (UDALL Erasm. Apoph. 299a)

Tables 19.1 and 19.2 show what is meant by generalization or bleaching: specific features of meaning drop off, leaving a semantic core. The classes of main verbs with which the auxiliary *can* is used generalize, as does the range of possible subjects of *can*. However, this is not all there is to the story. It must be remembered that both specific and general meanings of a gram can coexist; old uses may be retained in certain contexts (Bybee and Pagliuca 1987; Hopper 1991). Furthermore, tables 19.1 and 19.2 are just schematic summaries; they do not actually inform us of how the changes took place. The result is generalization of meaning and contexts of use, but what exactly was the mechanism by which this generalization occurred?

4.2 *From noun phrase complement to verb phrase complement (Old English)*

The ancestor of the modern auxiliary *can* is the main verb *cunnan*, which expresses various types of knowing.⁵ With a noun phrase complement denoting a person, a skill, or a language, the sense of knowing is acquaintance or acquired skill or knowledge (Goosens 1990). *Cunnan* is also used in the sense of understanding, as in “knowing the holy writings”:

- (6) Ge dweliað and ne cunnon halige gewritu
 “You are led into error and do not know the holy writings” (Ags. Gospel of Matthew xxii)

In order for a main verb such as *cunnan* to begin its development into an auxiliary, it must expand its syntactic distribution to take verb phrase objects. *Cunnan* had very limited use with infinitive objects in the Old English period, so that studying the specific contexts in which it was used with an infinitive can give us some idea of how the development may have taken place. The infinitives used with *cunnan* in Old English mostly fit into three semantic classes of main verbs: verbs of mental state or activity, verbs of communication, and verbs describing skills. Table 19.3 shows the 13 examples listed in the OED of *cunnan* used with an infinitive before 1100, plus the additional items listed by Goosens from his sample.

Table 19.3 Verb classes used with *cunnan* in Old English

OED		Additional items listed by Goosens (1992)	
Mental states or activities:			
<i>understandan</i>		<i>geþencean</i>	'to comprehend'
<i>ongietan</i> (2)	'to understand'	<i>behabban</i>	'to comprehend'
<i>točanawan</i>	'to distinguish, discern'	<i>wurðian</i>	'to esteem'
		<i>gecnawan</i>	'to perceive, know'
Communication:			
<i>secgan</i> (3)	'to say'	<i>sprecan</i>	'to speak'
<i>geandettan</i>	'to confess'	<i>tæcan</i>	'to teach'
		<i>læran</i>	'to teach'
Skills:			
<i>gretan hearpan</i>	'to touch a harp'		
<i>huntian</i>	'to hunt'		
<i>wunda sniðan</i>	'to cut a wound'		
Other:			
<i>afandian</i>	'to prove, try'		
<i>bebeorgan</i>	'to defend oneself'		

Goosens takes the mental state class as central and describes the other classes as related to this class more or less directly. There is no doubt that the mental state class is important, but when we consider how *cunnan* might have come to be used with infinitives, it seems likely that there were distinct motivations for the different semantic classes of verbs.

Since use of *cunnan* with mental state verbs is clearly important in Old English (and it continues to be important in Middle English), let us consider what would motivate the use of *cunnan* with verbs having a meaning that is so closely related to its own meaning. Indeed, meanings such as 'be able to know' and 'know how to understand' seem rather redundant. However, it is important to bear in mind that as a main verb, *cunnan* was already fairly frequent, and thus would have begun to lose some of its semantic force and specificity. I suggest that mental state infinitives then appear to be added in to bolster the meaning of *cunnan*, to flesh out the specific sort of knowledge intended in the context:⁶

- (7) He ne con ongitan forhwy swylc God geþafað
 he not *con* understand why such God allows
 "He does not understand why God allows such as that" (950 Alfred's
 Boeth. xxxix)

The near synonymy of ‘can’t understand’ and ‘doesn’t understand’ supports the idea that *con ongitan* is a harmonic phrase which means about the same as either component alone would mean. Perhaps *cunnan* is beginning to bleach and grow too weak to stand alone in such contexts.

In other cases, it is not clear whether the form of *cunnan* means ‘know how to’ or is expressing a meaning similar to the main verb:

- (8) Nu cunne ge tocnawan heofones hiw
 Now *cunne* 2p distinguish-INF heaven-GEN hue
 “Now you can distinguish/interpret heaven’s hue” (Ags. Gospel of Matthew xvi.3)

In this passage the speaker is pointing out to the addressees that they know how to and do in fact interpret the color of the sky at sunset and dawn to predict the weather.

Thus it appears that one avenue by which *cunnan* begins to grammaticize as an auxiliary is determined by the fact that it was already frequent, and had already undergone some weakening of its semantic content. Of course, the use of *cunnan* with infinitives whose meaning is a more specific version than that covered by *cunnan* results in the further weakening of its semantic content.

With verbs of communication and instruction, *cunnan* is used in contexts in which it retains its ‘knowledge’ interpretation: it is not used in quotative contexts but rather where the content of what is said is asserted to be based on accurate knowledge of facts:

- (9) þæt hi andsware secgan cunnen
 that they answer say-INF *cunn*-PL
 “That they can say the answer” (c.1000 Elena 374)
- (10) Weras þa me soðlice secgan cunnon
 man-PL then 1s-DAT truly say-INF *cunn*-PL
 “Then men can truly say to me” (c.1000 Elena 317)

The third verb class used with *cunnan* in Old English consists of those denoting skills, particularly those with a strong intellectual component, such as reading, writing, or singing, but not excluding the more physical, such as hunting. This verb class corresponds to a set of nominal objects frequently used with *cunnan*. The most frequent nominal or pronominal objects of *cunnan* refer to people, but the second most frequent set comprises objects that refer to intellectual skills.⁷ Thus we find ‘know the holy writing,’ ‘know songs,’ ‘know book-learning,’ ‘know letters.’ An infinitive construction could arise in these contexts by adding in the infinitive to an object that already consists of a noun phrase. Consider the following example, where the first instance of *cunnan* is followed by a noun phrase while the second has both a noun and an infinitive:

- (11) *ðy læs ðe him con leoða worn, oððe mid hondum con hearpan*
 unless 3s-DAT *con* song-PL many or with hand-PDat *con* harp
grētan, hafaþ him his gliwes giefe
 touch-INF have-3s 3s-DAT 3s-GEN glee-GEN gift
 “unless he knows many songs, or can (knows how to) touch the harp
 with his hands, has his gift of glee” (c.1000 *Versus Gnom.* 172)

In this case, it appears that the infinitive complement could develop directly out of the noun phrase complement as a vehicle for adding in more specific information about the skill being described.

The uses of these three verb classes in infinitival form with *cunnan*, then, appear to arise for different reasons, and perhaps are simultaneous developments. They are not necessarily totally independent, however. While each developing class of *cunnan* plus infinitive is a separate construction, it is plausible to assume that some more abstract generalization emerges from the similarities among these constructions.

Since the uses of *cunnan* are highly constrained lexically, they are appropriately described in a Cognitive Grammar (Langacker 1987) or associative Network framework (Bybee 1985, 1998) in which phrases or constructions are stored in the lexicon and generalizations are abstracted from these stored units. In this framework there is no strict separation of lexicon and grammar, but rather units of varying lengths and degrees of complexity may be stored lexically with the following properties: (i) the degree of strength or entrenchment of stored units is based on their text frequency; (ii) connections or associations of both a phonological and semantic nature are made among items, based on similarity or identity; and (iii) schemas of varying degrees of generality emerge from these representations.

A description of *cunnan* in Old English would require three quite specific schemas, one for each verb class, as shown in (12), and a more abstract schema, as in (13):

- (12) a. *cunnan* + V-infinitive
 ‘know’ {mental state, activity}
 b. *cunnan* + V-infinitive
 ‘know to’ {communicate, instruct}
 c. *cunnan* + NP (V-infinitive)
 ‘know how to’ {skill} ((do a skill))
- (13) *cunnan* + V-infinitive
 ‘know (how) (to)’ {activity involving mental capacity}

4.3 *Expansion to auxiliary status (Middle English)*

Since we are interested in how bleaching and generalization to new contexts take place, an appropriate time period to focus on is the Middle English period.

Once more our concern will be the semantic classes of verbs that appear in infinitival form with *can*. To determine the relative text frequency of the verb classes and individual members of these classes, it is necessary to examine all instances of *can* + infinitive in a stretch of text. For this purpose I have chosen the works of Geoffrey Chaucer and have examined the first 300 uses of *can* + infinitive listed in *A Concordance to the Complete Works of Geoffrey Chaucer* (Tatlock and Kennedy 1927), which includes all of the *Canterbury Tales*, most of *Troilus and Criseyde*, and several shorter poems.⁸

First we observe that the three verb classes that appeared with *cunman* in Old English are still strongly represented in Middle English (in the following, the verbs are rendered in their Modern English spelling, unless that distorts the meaning or shape of the verb radically):

- (14) Intellectual states or activities (52 tokens, 18 types):
deem, believe, see, know, guess, understand, *espy* (discover), judge, construe, imagine, comprehend, conclude, bethink, remember, find a difference, find a reason, shape a remedy, (wit) suffice
- (15) Communication (102 tokens, 31 types):
clepen (name), *devyce* (describe), thank, say, tell (or count), express, expound, make mention, make a description, make by argument, answer, cry, bewail, speak, report, swear, lie, preach, *reherce* (describe), declare, reckon, amend, beguile, portray sorrow, assure, describe, write, complain, record, define, *distreyne* (urge), treat
- (16) Skills ('know how to') (26 tokens, 18 types):
read, gloss, form, paint, *counterfete* (imitate), shape, do craft, do craftily, delve in herbs, work in philosophy, sing, dance, joust, play an instrument, play, entune, sound, make a beard

The frequency increase of *can* from Old to Middle English is manifested both in the use of *can* with a larger number of verbs of each class (i.e., type frequency) and in the development of a high token frequency for some combinations in the intellectual state and communication classes. Both kinds of frequency contribute to the bleaching of the meaning of an element.

Because of certain commonly used fixed phrases, the token-to-type ratio in the "intellectual states and activities" class and the "communication" class is approximately three to one. Here are the most commonly used main verbs:

- (17) Communication class:
- | | | |
|-----------------------|--------------------------|----|
| High token frequency: | tell | 30 |
| | say | 29 |
| | <i>devyce</i> (describe) | 8 |
| Type frequency: | 31 distinct verbs | |

(18) Intellectual states or activities:		
High token frequency:	see	12
	deem	6
	understand	6
	<i>espy</i> (discover)	5
Type frequency:	18 distinct verbs	

In the associative Network or Cognitive framework described above, type frequency corresponds to the generality of the schema, which in turn corresponds to a higher degree of grammaticization. High token frequency corresponds to a local schema that is very strong or highly entrenched, such as *can say*, *can tell*, or *can see*. Increases in frequency of both types lead to the continued bleaching of the meaning of *can*.

Actually, the phrases listed above are abstractions from larger ritualized phrases found frequently in the Chaucer texts, phrases such as the following:

- (19) I kan say yow no ferre (farther) (A. Kn. 2060)
 I kan say you namoore (B. ML. 175; B. NP. 4159; G. CY. 651)
- (20) more than I kan telle (B. ML. 1120)
 mo than I kan make of mencioun (A. Kn. 1935)
 more than I kan yow devyse (describe) (B. ML. 429)
- (21) I kan nat seen (that) (B. Mel. 2735; TC II 794; TC IV 1365)

Each of these can be viewed as a construction with varying degrees of generality and varying degrees of entrenchment.

The Chaucer texts also reveal that the use of *can* with infinitives has expanded to other semantic classes of verbs, that is:

- i verbs denoting states of mind that are not strictly intellectual, such as *love*, *suffer*, *have patience*, etc.;
- ii verbs denoting states that are not mental or emotional: *be wrye* (twisted), *be rotten*, etc.;
- iii verbs indicating a change of state in another person. These are probably related to verbs of instruction of Old English: *teach*, *heal*, *comfort*, *disturb*, etc.;
- iv verbs indicating an overt action: *ride*, *go*, *send*, *climb*, *steal*, etc.

It is plausible to assume that these verb classes arose out of the earlier three classes gradually, since lines between semantic classes of verbs are not discrete (cf. the study of Kemmer 1995). I propose the following developments:

- (22) 'know' > 'experience'
 main predicates: Intellectual states > States of mind > States

- (23) 'know to tell' > 'know how to' > 'be able to'
 main predicates: Instruction > Change of state (transitive)
- (24) 'know a skill' > 'be able to'
 main predicates: Mental skills > Physical skills > Overt action

By the time these developments have occurred, there are very few predicates that cannot be used with *can*. Despite the generality with main predicates, *can* does not yet express root possibility with any regularity, since use with inanimate subjects is extremely rare: only 12 examples are found in the corpus of 300 and all but two of these are metonymic expressions for humans, that is, "inanimate" objects such as the eyes, the heart, wit, foolishness, and beauty. Two other inanimate objects that can tell or hide (the truth) are a book and the gossip or prattle (of women):

- (25) As ferforth as my wit kan comprehend
 "As far as my wit can comprehend" (TC IV 891)
- (26) Swich vanyte ne kan don hire non ese
 "Such foolishness cannot please her" (TC IV 703)

It appears that the most general schema for *can* in Chaucer's English is centered on human subjects and is only occasionally extended beyond humans to aspects of their behavior or metonymic uses of mind-body parts (such as eyes and wit). The most general schema, (27), does not have restrictions on the type of main predicate *can* occurs with. The tendency to use *can* commonly with certain semantic classes of verbs is captured in more specific schemas referring to the verb types listed in (22) through (24) or covering very specific constructions, such as those represented in (19) through (21):

- (27) {human subject} *can* + infinitive
 {know how to}
 {experience}
 {be able to}

At this period, *kan* has generalized to expressing human ability of all types, but it has not yet generalized beyond ability to include root possibility.⁹

4.4 Further generalization: root possibility

General ability is very closely related semantically and functionally to root possibility. While ability applies only to properties internal to an agent, root possibility includes both internal and external enabling conditions. It is paraphrasable as "it is possible for *x* to *y*." Thus in one of the few examples of

root possibility in the Chaucer texts, we can see how this paraphrase would apply:

- (28) Til we be roten, kan we nat be rype
 “Until we are rotten, it is not possible for us to be ripe” (A. Rv. 3875)

The close relation of ability to root possibility is due to practical considerations in the real world: the ability to do something often depends on both internal and external conditions. Thus in this example, again from Chaucer, it is difficult to tell if the conditions are internal, external, or both:

- (29) Allas! kan they nat flee the fires heete? (G. CY. 1408)

Later in the Middle English period, examples interpretable as root possibility become much more common, and the syntactic conditions under which *can* is used continue to shift. In particular, the root possibility reading makes the use of *can* with stative predicates and in passive clauses possible, as the following two examples show:

- (30) No worldely thyng can be wythout stryfe. (1509 Hawes Past. Pleas. xvi.xlix)
 (31) Gij, But and thou array thy body sumptuously thou canst not be excused as chast in mind. (1540, Hyrde Vives’ Instr. Chr. Wom. 1592)

Also examples of *can* expressing capacity, a use close to root possibility, appear in the sixteenth century:

- (32) There is great number that fayne would aborde
 our ship can holde no more. (Barclay Ship of Fooles 1570)

In this use, *can* begins to replace *may*, which, as we noted above (n. 9), was much used in the root sense in Chaucer’s works. *May* is undergoing its own development, however, and beginning to be used more often in the epistemic sense (“it is possible that”).

This brief survey of the development of *can* from Old to Middle English illustrates how the sharp frequency increase takes place: (i) the grammatical construction (*can* + infinitive) gradually extends to use with more and more types of verbs and then subjects; this extension is based on semantic similarity among the verbs in question, but its result is a generalization or bleaching of the meaning of *can*; (ii) certain phrases have a high token frequency, which also serves to bleach the meaning of their component parts. The result is a major change from the meaning of *cunnan*: in these root possibility readings of (30), (31), and even (32), no hint of the meaning of *cunnan* as ‘know’ remains.

5 Phonological Changes

A recognized concomitant of grammaticization is reduction in phonological form. In a large cross-linguistic sample, Bybee et al. (1991, 1994) demonstrate a significant association between degree of semantic grammaticization and phonological reduction, particularly in the length of the grams in question, but also in the degree of fusion of the gram with surrounding material.

The previous section illustrated in some detail the way increases in token and type frequency occur over time. In this section we will examine the link between frequency, phonological reduction, and fusion of grammaticizing phrases. The example of *can* is less useful here, since it is a single monosyllable, so other examples will be taken up. It should not be concluded, however, that *can* has undergone no phonological reduction just because its orthographic shape is fairly constant. Since the Old English period it has lost the final inflectional syllable that occurred in many forms (*cunnan*, *cann*, *canst*, *cunnon*, *cunne*) as have other verbs, and furthermore, in Modern English, *can* is phonetically reduced to [kɪ] or [ɪ] in high frequency contexts, such as after the pronoun *I*.

5.1 Phonological reduction

Recent studies of the lexical diffusion of regular sound changes have shown that in many cases, high frequency words undergo sound change at a faster rate than low frequency words. The effects of frequency have been shown for vowel reduction and deletion in English (Fidelholtz 1975; Hooper 1976a), and for the raising of /a/ to /o/ before nasals in Old English (Phillips 1980), for various changes in Ethiopian languages (Leslau 1969), for the weakening of stops in American English and vowel change in the Cologne dialect of German (Johnson 1983), for ongoing vowel changes in San Francisco English (Moonwomon 1992), for tensing of short *a* in Philadelphia (Labov 1994: 506–7), and for t/d-deletion in American English (Bybee 2001: 23ff, 112ff, 151ff).

Pagliuca and Mowrey (1987) argue that when one views articulation in terms of sets of overlapping gestures, all sound change can be classified as due to Substantive Reduction – the reduction in the magnitude of a gesture – or Temporal Reduction – the reduction in the duration of a constellation of gestures, resulting in the shortening of individual gestures or the increase in the overlap of gestures. This hypothesis is meant to explain the dominance of weakening and assimilation in attested sound changes. Browman and Goldstein (1990, 1992) make a very similar claim for casual speech processes (which I take to include the same range of phenomena as the category “sound change”). Browman and Goldstein hypothesize that all casual speech processes result from either the reduction in magnitude of a gesture, or the increase in the overlap of gestures.

These hypotheses await further investigation, but even if they turn out to have some counterexamples, the fact will remain that a large proportion of phonological changes are reductive in nature. Thus it is reasonable to ask why reductive changes would affect high frequency words or phrases earlier and at a faster rate than low frequency words and phrases. Several factors can be identified.

First, Fowler and Housum (1987) found that the second repetition of the same word in a single discourse was significantly shorter than the first token of the word. The speaker can be less explicit about the articulation of a word if it has already been used, because it will be easier for the listener to access if it has just been activated. Furthermore, Fowler and Housum point out that the reduction can actually be a signal to the listener that the word being used is just the same as one used earlier rather than a new and different word. It would follow then, that words or phrases that are often repeated in the same discourse (high frequency and grammaticizing phrases) would be in position to be shortened more often than words and phrases of low frequency.

Second, D'Introno and Sosa (1986) point out that frequency effects in the spread of a sound change are better viewed as familiarity effects: their position is that it is not so much the frequency of a word but rather its use in casual or familiar social situations that allows it to reduce or undergo change at a faster rate. Since the changes in question occur more often in casual speech, words that are used more often in casual speech will be more often subjected to the change.

Other factors might be involved as well, especially for grammaticizing constructions: as meaning generalizes, the informational contribution of the grammaticized elements decreases and along with that the intonational and rhythmic emphasis. Such prosodic reduction will have an effect on the segmental properties of the phrase as well.

For all of these reasons (and perhaps others), increasing frequency of use of grammaticizing constructions leads to phonological reduction. While the reduction is extreme in many cases, it usually follows patterns that are also seen in ongoing or future sound changes, suggesting that it is the frequency of use that hastens the changes. For instance, in Old Spanish, the second person plural suffix was *-des* (from Latin *-tis*), and was preceded by a stressed vowel: *-ádes*, *-édes*, or *-ídes*. In Old Spanish this medial *d* (pronounced [ð]) was gradually deleted, so that in Modern Spanish (in the dialects that use it) the forms are *-áis*, *-éis*, and *-ís*. Currently in most dialects of Spanish other instances of medial [ð] are gradually deleting. What is interesting is that this earlier morpheme-specific change was an instance of a more general change that would be current many centuries later.

Other instances of phonological reduction in grammaticization seem more extraordinary, but even most of these can be analyzed into steps that reflect the general reduction patterns of the language. For example, *going to* [gõm tuw] reducing to *gonna* [gõnã] or even further, as in *I'm gonna* reducing to [aimãrã], involves the following: (i) the reduction of full [o] to schwa; (ii) change of the velar to alveolar nasal; (iii) vowel nasalization; and (iv) flapping,

all of which occur in other words as well. On the other hand, certain aspects of this reduction are extraordinary: (i) reduction of the diphthong [oi]; (ii) flapping of [nt]; and (iii) deletion of [g] in [aimãrã].

5.2 Phonological fusion

Besides the reduction of the consonants and vowels within words, grammaticization often involves the phonological fusion of words or morphemes that formerly were separate. Here frequency is at work as well. Combinations of words and morphemes that occur together very frequently come to be stored and processed in one chunk. Boyland (1996) points out that as high frequency sequences of units come to be processed as single units, their gestural representation changes: what were previously multiple gestures come to be reorganized into single gestures and along with this reorganization comes reduction and increased overlap of gestures.

In Bybee and Scheibman (1999), we have shown that the reduction of the auxiliary *don't* in English is most extreme in precisely the phrases in which it most commonly occurs. Out of 138 occurrences of *don't* from spontaneous conversation, 87 occurred after the first singular pronoun *I*, making this the most common element to precede *don't*. There were 51 tokens in which the vowel was reduced to schwa and 50 of these occurred with *I*. (The other token was in the phrase *why don't you*, used to make a suggestion.) The reduction to schwa was also influenced by the following verb. The most common verb to follow *don't* was *know*, and 29 of the tokens with a schwa occurred with this verb. In fact, 29 out of 39 cases of *don't know* were reduced and all of these were in the phrase *I don't know*. The second most common verb to be used with *don't* was *think*, and 7 out of 19 of these cases, again all with *I*, were reduced to schwa. Other phrases in which *don't* was reduced were *I don't have (to)*, *I don't want*, *I don't like*, *I don't mean*, *I don't feel* and *I don't care*. The reduction did not occur with any other pronouns with the 20 other verb types found in the conversations.

We concluded that neither phonological nor syntactic conditioning is responsible for the reduction of *don't*, but rather that this reduction occurs inside of automated processing units, chunks that are automated primarily because they occur with high frequency. As *I don't know* comes to be produced as a single unit, the medial syllable loses its stress, allowing the vowel of *don't* to reduce.

6 Autonomy

Another consequence of a high frequency of use of a word or phrase consisting of multiple morphemes is a growing autonomy from other instances of these

same morphemes. Bybee (1985) argues that token frequency is an important determinant of semantic split among derivationally related words. That is, derived words that are of relatively high frequency (compared to their base form) are more likely to be semantically opaque and to have additional meanings or nuances not present in the base form. The reason for this is that high frequency words are present enough in the input to have strong representations of their own; they do not have to be understood in terms of other related words.

The same process applies to grammaticizing phrases – they gradually grow increasingly independent of their composite morphemes and other instances of the same construction. Thus the phrase (*be*) *going to* is becoming less and less associated with the individual morphemes, *go*, *ing*, and *to*, until a point may well come when speakers are surprised to find out what its etymological source is. Similarly, but on a different plane, (*be*) *going to* has disassociated itself from other instances of the construction, as given in (1). Such dissociations are phonological, semantic, and morphosyntactic.

Dissociations due to growing autonomy of grammaticizing phrases account for the splits that are often found between a morpheme in a grammaticizing phrase and its lexical source (Heine and Reh 1984; Hopper 1991). French *pas* in the negative phrase *ne . . . pas* is no longer associated with its etymological source, the noun *pas* meaning ‘step.’ The forms of *avoir* in French are still used for possession, but are also found in the construction of the Passé Composé (*j’ai chanté, tu as chanté, il a chanté*, etc.) and in the formation of the Future (*je chanterai, tu chanteras, il chantera*, etc.). In these three uses, despite similarities of phonology, these forms are best analyzed as autonomous from one another; they occur in different constructions and their meanings are in no way transparently related across these constructions.

7 New Pragmatic Associations

The autonomy of grammaticizing phrases and their growing opacity of internal structure makes it possible for new pragmatic functions to be assigned to them. Such new functions originate in the contexts in which the expressions are frequently used.

As an example, consider the phrase *I don’t know* as used in colloquial American English. As mentioned above, this phrase can reduce to [aɪrənə] or [aɪnən]. While it can be used with its literal meaning as an answer to a question, it can also be used in conversation to mitigate an assertion or to politely disagree or refuse something being offered (Scheibman n.d.). In these cases, *I don’t know* is a single processing unit that is losing its association with the words from which it was derived. Due to its growing autonomy, it is capable of taking on new discourse functions that arise from the contexts in which it is commonly used.

8 Entrenchment: The Evolving Morphosyntactic Properties of English Auxiliaries

Another effect of high token frequency on complex forms is their maintenance of conservative structure despite the pressure of productive patterns (Bybee 1985). High token frequency explains why some English verbs (*ate, broke, wrote*) retain their irregular vowel changes despite the extreme productivity of the *-ed* affix for expressing past tense. High frequency constructions can also retain conservative morphosyntactic characteristics even in the face of new productive morphosyntactic patterns. Bybee and Thompson (1997) argue that even morphosyntactic constructions can exhibit this type of entrenchment due to the strength of the representation of the construction.

It is well known that English modal auxiliaries (*can, could, may, might, will, would, shall, should, and must*) have a set of syntactic properties that distinguish them from main verbs: the use of a bare infinitive, subject inversion in questions and other contexts, and the placement of the negative immediately following the auxiliary. How did these properties develop? Space is not available here for a detailed treatment of these properties, but the basic answer is that these properties were once variable properties of all verbs, but they have become conventionalized in these high frequency verbs, while all other verbs changed their properties in accordance with the changing syntax of the English language.

Consider first the use of the bare infinitive rather than the *to*-infinitive. In Old English, the infinitive was formed by adding *-an* to the verb stem. Thus verb + infinitive constructions in Old English had no intervening *to*. With general reduction of final syllables and the loss of inflections in verbs and nouns, the infinitive suffix gradually disappeared. Long before this suffix was lost, however, a new infinitive marker began to develop in the form of the preposition *to*. Haspelmath (1991) has shown that the primary source of infinitive markers cross-linguistically are allative or dative markers, which are first used in purpose clauses and subsequently generalized to other infinitival uses. This is exactly what happened in English: *to* with the infinitive (an erstwhile verbal noun) inflected in the dative was first used in purpose clauses and gradually extended to general use as an infinitive marker. During the Middle English period there was still some variation in the use of infinitives with and without *to*.¹⁰

Modals such as *can* have very consistently occurred throughout their history in constructions without *to*. The reason for this is that these constructions were first created and apparently entrenched before *to* developed as the infinitive marker. Since constructions with the modal auxiliaries were of high frequency and thus highly entrenched, they were not reformulated after the *to*-infinitive generalized in the language. The same is true of other verb + infinitive constructions that have survived from the Old English period. For instance, *go* +

infinitive and *see* + infinitive constructions use bare infinitives even today: *Let's go see; I saw him do it*. More recent formations with functions similar to those of the modal auxiliaries, such as *want to, be going to, have to*, use the newer infinitive construction that was established before these constructions became entrenched. Thus it is the fact that the constructions with *can* + infinitive arose before the *to*-infinitive and the fact that they were of high frequency that together explain why *can* uses a bare infinitive.

Another striking characteristic of the class of auxiliaries to which *can* belongs today is that they invert with the subject in certain constructions, primarily questions, but also (perhaps archaically) in conditional protases lacking *if*, and in clauses with fronted negative elements. In the Middle English period this verb–subject order in these contexts was a variable property of all verbs; it was not restricted to auxiliaries (Mossé 1952: 126–8). Consider these examples:

- (33) Gaf ye the chyld any thyng?
 “Did you give the child anything?”
- (34) Ne sunge ich hom never so longe,
 Mi songe were i-spild ech del
 “Even if I sang to them ever so long, My song would be entirely lost (on them)”

Since the modal auxiliaries and *be* and *have* as auxiliaries were becoming increasingly frequent in this period, they would commonly occur before the subject in these contexts. While other verbs eventually ceased to appear in this position, taking instead the position after the subject which eventually became obligatory, the auxiliaries, including the newly developed pro-verb, *do*, remained in inverted positions in these special constructions. Again it is their high frequency that accounts for their conservative behavior. The constructions with inverted auxiliaries were highly entrenched and thus not prone to revision despite the other syntactic changes occurring in English.

The position of the negative *not* after *can* and other auxiliaries has a similar diachronic explanation. The sentence negation particle in Old English, *ne*, occurred before the verb, but in Middle English, it was reinforced by another negative *nought, not*, which derived from *ne + wiht* (literally: ‘not a creature’). *Not* occurred after the verb in Middle English and became the normal negative marker as the preposed *ne* was lost. It occurred after simple finite main verbs as well as after the auxiliary (Mossé 1952: 112):

- (35) My wyfe rose nott
- (36) cry not so

The position of the negative after *can* and other auxiliaries is the preservation for this high frequency group of the order that once applied to all verbs. While

other verbs require the use of *do*-support, the auxiliaries have simply continued to participate in the highly entrenched construction that was established in the fourteenth century.

Thus it can be said that the special properties of the auxiliaries in English are the retention of older morphosyntactic properties that were once general to English verbs. These modal auxiliaries and the other auxiliaries, *be*, *have*, and *do*, have retained these properties because of their high frequency: due to repetition their participation in certain constructions is highly entrenched and not likely to change. By the same token, modal constructions developing more recently will reflect the morphosyntax of the period in which they develop and are highly unlikely to fall in with the older modals and take on their characteristics, such as using the bare infinitive and occurring before the subject in questions.

This preservation of older morphosyntactic characteristics in high frequency constructions can be attributed to the same mechanism as the preservation of irregularities (older morphological properties) in inflected forms. While analogical change generally operates to level or regularize morphophonemic alternations (e.g., as *wept* becomes *weeped*), forms with high token frequency tend to resist such change (e.g., *kept* is not becoming *keeped*); see Anttila, Dressler, and Hock, all this volume).

9 The Effects of Repetition

This survey of the changes that occur in grammaticization has revealed that repetition affects semantics and phonology by promoting change, in particular, reductive change, and that repetition affects morphosyntax by ensuring the retention of older characteristics. It might seem contradictory that repetition could both encourage innovation in one domain and enhance conservatism in another. This paradox is also found in the lexical diffusion of phonetic versus morphophonemic change. In Hooper (1976a), I pointed out that sound change affects high frequency items first, while analogical leveling affects low frequency items first. The substantive properties of words or phrases, their meaning and phonetic shape, are modified, usually reduced, with use. The ritualization or automatization process has an on-line effect of compressing and reducing; this is a processing effect. In contrast, the structural properties of words and phrases – that is, the morphological structure of words and the syntactic properties of constructions – are preserved by repetition; this is a storage effect. Frequently used words and phrases are highly entrenched and more likely to be accessed as whole units and less likely to be reformed on-line. Thus their general structure – the morphological irregularity of high frequency nouns and verbs, or the structure of high frequency constructions – will tend to be preserved. We can say, then, that repetition has a reductive effect on-line, but a conserving effect in storage.

Repetition is universal to the grammaticization process. Repetition and its consequences for cognitive representation are major factors in the creation of grammar. The conventionalized aspects of language provide the framework for manipulation of our thoughts into objects of communication. Repetition alone, however, cannot account for the universals of grammaticization. The fact that the same paths of change are followed in unrelated languages has multiple causes. It is not just the fact of repetition that is important, but in addition *what* is repeated that determines the universal paths. The explanation for the content of what is repeated requires reference to the kinds of things human beings talk about and the way they choose to structure their communications.

ACKNOWLEDGMENT

The author wishes to thank John Haiman, Barbara Need, Sandra Thompson, and Elizabeth Traugott for helpful comments on an earlier draft of this chapter.

NOTES

- 1 Care must be taken here to distinguish between meaning and use: as a gram loses specific features of meaning, it appears to take on more uses. Being used in a wide range of contexts does not mean that the gram has *more* inherent meaning.
- 2 At the end of the grammaticization process, an old gram may be restricted in use by newer grams that replace some of the uses of the older one. The consequent addition of contextual meanings to the old gram may appear to make meanings more restrictive.
- 3 The permission use of *can* is not treated here. In Bybee and Pagliuca (1985) and in Bybee et al. (1994), we argue that the permission use of grams originally expressing ability develops out of the root possibility sense. Root possibility expresses a highly generalized set of enabling conditions, which include the social conditions that govern permission.
- 4 Abbreviations for examples from Chaucer are: B. Mk. (Monk's Tale); A. Kn. (Knight's Tale); B. NP. (Nun's Priest's Tale); B. ML. (Man of Law's Tale); G. CY. (Canon's Yeoman's Tale); B. Mel. (Tale of Melibeus); TC II (Troilus and Criseyde, book 2); TC IV (Troilus and Criseyde, book 4); A. Rv. (Reeve's Tale). All other abbreviations are from the OED and follow the OED's format for dates and details for locating the example in the text: date of publication, author/title of work, chapter, page number, etc.
- 5 The Past Tense of *cunnan*, OE *cufþ*, which gives Modern English *could*, will not be treated here. See Bybee (1995) for the development of Past Tense modals in English.
- 6 Lyons (1977) refers to cases in which two modals of similar meaning co-occur in a clause

- without increasing or decreasing the degree of modality as modal harmony. *Cunnan* 'to know' plus a verb of knowledge could be regarded as an harmonic expression.
- 7 This is true of Goosen's sample and the small OED sample consulted.
 - 8 There are several varieties subsumed under Old English and even more under the designation Middle English, so it cannot be assumed that there is necessarily a direct developmental relation between the languages represented in the texts used here. Still it is clear that in some general sense a type of diachronic relation exists.
 - 9 In Chaucer's English, root possibility is expressed by *may*, which derived from a verb expressing physical power or ability. *May* is more grammaticized semantically than *can*: in the Middle English period it is used frequently with inanimate and generic subjects to express root possibility. It is also commonly used in subordinate clauses and is even beginning to express epistemic possibility in some contexts (see Bybee 1988).
 - 10 Indeed in Modern English there is still variation between the bare infinitive and the infinitive with *to*, as in *help someone (to) do something*.

20 Constructions in Grammaticalization

ELIZABETH CLOSS TRAUOGOTT

A standard definition of grammaticalization is that it is the process whereby lexemes or lexical items become grammatical.¹ Yet the equally standard examples of the process, such as body part terms becoming adpositions (e.g., *by (X's) side*), or motion verbs becoming auxiliaries (e.g., *be going to* > “future” *gonna*), typically involve not bare lexemes but morphosyntactic strings, or in most cases more properly constructions. While the focus of most definitions of grammaticalization in the linguistic literature has been on lexemes (and, in later stages, the grammaticalization of already grammatical items into more grammatical ones, e.g., auxiliary verbs into affixes), increasing attention has recently been paid to the fact that early in grammaticalization, lexemes grammaticalize only in certain highly specifiable morphosyntactic contexts, and under specifiable pragmatic conditions. This concept of grammaticalization as a fundamentally relational and context-dependent process has its origins in Meillet’s work, and is therefore in no way new. However, the research agendas of practitioners of grammaticalization theory have developed in rather different ways depending in part on whether the focus is on lexemes or on the contexts in which they take on grammatical functions. The present chapter explores some of the consequences of thinking about grammaticalization when the starting-point is “the observation that grammatical morphemes develop gradually out of . . . combinations of lexical morphemes with lexical or grammatical morphemes” (Bybee et al. 1994: 4), and when context is highlighted.

The concept of processes leading from words to affixes, and from concrete to more abstract meanings has been widely discussed from the eighteenth century on (see Heine, this volume; Lehmann 1982: ch. 1; Heine et al. 1991: ch. 1; Hopper and Traugott 1993: ch. 2), but the term “grammaticalization” seems to have originated at the beginning of the twentieth century with Meillet. He defined it as: “le passage d’un mot autonome au rôle d’élément grammatical . . . l’attribution du caractère grammatical à un mot jadis autonome”² (Meillet 1912: 131). In the same article he also proposed that word order changes, such

as those from relatively free word order in Latin to more restricted word order in Romance languages, might be cases of grammaticalization. Despite this insight, until recently most work on grammaticalization has ignored the issue of word order, or specifically excluded it (e.g., Heine and Reh 1994),³ and has focused instead on the recruitment of lexemes into grammatical functions. For example, after citing Meillet's definition above and Kuryłowicz's similar formulation (1965), Lehmann says in an influential article: "[u]nder the diachronic aspect, grammaticalization is a process which turns lexemes into grammatical formatives and makes grammatical formatives still more grammatical" (1985: 303).

Earlier, however, in his pioneering 1982 working paper, *Thoughts on Grammaticalization* (published in slightly revised form as a book in 1995), Lehmann had pointed out that in grammaticalization "[a] number of semantic, syntactic and phonological processes interact in the grammaticalization of morphemes and of whole constructions" (1982: viii). This position is significantly strengthened in general in Lehmann (1993) and expressed eloquently elsewhere; consider, for example, the following statement: "grammaticalization does not merely seize a word or morpheme . . . but the whole construction formed by the syntagmatic relations of the element in question" (Lehmann 1992: 406). The attention to constructions is hardly surprising given that Lehmann's prime examples are "verbal complexes" (specifically, the potential of main verbs to develop into auxiliaries and ultimately affixes provided they are in some kind of construction with other verbs, e.g., a serial verb construction), "nominal complexes" (the potential of relational nouns to develop into case markers provided they are in adpositional relationships with another nominal), and clausal relations such as subject-verb agreement (arising out of topic structures, and clearly also relational).

As the multiplicity of examples grew involving relationships between lexemes and grammaticalization, more attention began to be paid on both sides of the Atlantic to the role of "phrases" or "constructions," and definitions of grammaticalization such as the following began to appear: "the process whereby lexemes and constructions come in certain linguistic contexts to serve grammatical functions" (Hopper and Traugott 1993: xv) and "the evolution of grammatical form and meaning from lexical and phrasal antecedents" (Pagliuca 1994: ix). In these definitions, "construction" is used in a pre-theoretical way, as it will be in the rest of this chapter, though recent work in construction grammar (e.g., Goldberg 1995; Fillmore and Kay forthcoming) and models sympathetic to it (e.g., Head Driven Phrase Structure Grammar), all designed for synchronic purposes, have obvious relevance for the kind of approach proposed here. Although grammaticalization typically results in morphosyntactic constructions, the combinations on which it operates are also morphophonological. Morphophonological constructions are intonation units, including pitch and duration contours (see, e.g., Zwicky 1982; Chafe 1994; Langacker 1994; the importance of intonation units in incipient grammaticalization is highlighted in Givón 1991; Croft 1995; among others).

In thinking about a theory of grammaticalization it is essential to have a clear concept of “grammar” in mind, for the most crucial point about grammaticalization is that it is a process whereby units are recruited “into grammar.” Only the briefest statement is possible here. To contextualize the discussion that follows it must suffice to mention that I see grammar as structuring communicative as well as cognitive aspects of language. Grammar encompasses phonology, morphosyntax, and truth-functional semantics, and is rich enough to license interaction with the general cognitive abilities such as are involved in the speaker–addressee negotiation that gives rise to grammaticalization. These include information processing, discourse management, and other abilities central to the linguistic pragmatics of focusing, topicalization, deixis, and discourse coherence.

Grammaticalization phenomena are essentially gradient and variable. They proceed by minimal steps, not abrupt leaps or parametric changes, though accumulated instances of grammaticalization might eventually in some cases lead to these, or at least to some major category changes. A much-discussed example is the development of syntactic auxiliaries in the history of English (for different analyses, see Lightfoot 1991; Warner 1993; and references therein). Such small changes involve reanalysis of form–function pairs by processes of abduction (Andersen 1973), often in ways so minimal as to challenge recent distinctions between reanalysis and analogy (see especially Tabor 1994a, who argues from the framework of connectionist grammar for “attractor” structures that constrain trajectories of change). Although children no doubt play a part in language change, our written historical records give us no direct access to child language acquisition. Furthermore, many examples of grammaticalization, including many discussed in this chapter, seem likely to have been initiated by adults rather than children, because of the complex inferences involved and the discourse functions in structuring text. As Slobin points out in discussing the discourse origins of the present perfect in English: “children come to discover pragmatic extensions of grammatical forms, but they do not innovate them; rather, these extensions are innovated diachronically by older speakers, and children acquire them through a prolonged developmental process of conversational inferencing” (Slobin 1994: 130). Therefore grammaticalization needs to be understood within a theory of grammar that does not privilege parametric resettings or child language acquisition over other aspects of language and acquisition of language.

The outline of the chapter is as follows. Section 1 introduces some widely held assumptions about structural and semantic-pragmatic properties of grammaticalization, and how to account for them. In section 2 examples are discussed from the nominal and adverbial domains in the history of English,⁴ in particular, the recruitment of prepositional phrases or adverbs to serve other grammatical functions: locative *in stead of* which acquired a new function as a substitutive connective, and the manner adverbials *indeed*, *any way*, which acquired new functions as discourse markers. My purpose is to demonstrate how focus on grammaticalization as centrally concerned with the development

of lexemes in context-specific constructions (not merely lexemes *and* constructions) potentially expands the boundaries of what is often considered grammaticalization. This will be achieved by pointing to the similarities between standard kinds of examples and others which have been or might be excluded either because they violate certain assumptions about structural unidirectionality in grammaticalization, or because the view of grammar espoused has not envisaged the importance of studying interfaces with pragmatics. Implications of the data for the kinds of theories outlined in section 1 are suggested in section 3.

1 Some Theories about Structural and Semantic-Pragmatic Properties of Grammaticalization

1.1 *Structural issues*

The beginnings of recent work on grammaticalization, especially in the United States, are largely to be found in explorations of (morpho)syntactic change (see, e.g., papers in Li 1977). A natural outcome was a focus on structural issues. One of the key hypotheses was that of unidirectionality, conceptualized in terms of structural simplification and optimization of grammars: "It would not be entirely inappropriate to regard languages in their diachronic aspects as gigantic expression-compacting machines" (Langacker 1977: 106). When Meillet introduced the term "grammaticalization" into the metalanguage of linguistics, and defined grammaticalization in terms of shifts from lexical to grammatical item, he had already emphasized the notion of structural unidirectionality. His definition cited above is unidirectional insofar as it suggests that lexemes become grammatical, and that grammatical ones do not normally become lexical.⁵ His tentative suggestion that word order change from relatively free to more rigid order might be a kind of grammaticalization was also a unidirectional statement.

The hypothesis of unidirectionality is intimately tied up with structural clines, which form the backbone of work on grammaticalization, specifically a nominal cline:

- (1) relational noun > secondary adposition > primary adposition > agglutinative case affix > fusional case affix (Lehmann 1985: 304)

and a verbal cline, which has been formulated in various ways, such as:

- (2) a. lexical verb > auxiliary > affix (Givón 1979: 220–2)
- b. full verb > predicative construction > periphrastic form > agglutination (Ramat 1987: 8–12)

Table 20.1 Correlation of grammaticalization parameters

Parameter	Weak grammaticalization	– Process	→ Strong grammaticalization
Integrity	Bundle of semantic features; possibly polysyllabic	– Attrition	→ Few semantic features; oligo- or monosegmental
Paradigmaticity	Item participates loosely in semantic field	– Paradigmaticization	→ Small, tightly integrated paradigm
Paradigmatic variability	Free choice of items according to communicative intentions	– Obligatorification	→ Choice systematically constrained, use largely obligatory
Structural scope	Item relates to constituent of arbitrary complexity	– Condensation	→ Item modifies word or stem
Bondedness	Item is independently juxtaposed	– Coalescence	→ Item is affix or even phonological feature of carrier
Syntagmatic variability	Item can be shifted around freely	– Fixation	→ Item occupies fixed slot

Source: Lehmann (1982: 164), reproduced by permission of LINCOM EUROPA

The clines are conceptualized in terms of coalescence or reduction of freer and segmentally fuller material into more bonded, segmentally more restricted material; for example: "Once affixation has occurred, grams do not ordinarily detach themselves and assume a free form again, so that growing dependence on surrounding material is not usually reversed" (Bybee et al. 1994: 13).

Terminology such as "cline," "coalescence," "gradualness," and "gradience" has tended to be misleading and has suggested to some that the moment of grammaticalization of an individual item or construction is meant on theoretical grounds to be unidentifiable. For example, in her very interesting article on the emergence of grammars in creole contact situations, Bruyn (1996: 39) argues that such situations reveal that, contrary to usual assumptions, "more or less instantaneous grammaticalization may take place." The terminology of clines and gradualness is meant to highlight the fact that the changes that are the subject of grammaticalization studies are local and minimal, not primarily "cataclysmic" or "parametric" in the sense of generative historical syntax (e.g., Lightfoot 1979, 1991). It is, however, incoherent to think of, for example, the reanalysis of a lexical verb as an auxiliary as a literally gradual process. Reanalysis (innovation), however small the steps by which it proceeds, is abrupt at each step (Hopper and Traugott 1993: 36). What is gradual is the typically slow accretion of properties that lead up to the reanalysis. So is the gradual spread of an innovation through the system (e.g., the spread of auxiliary status from one verb to another in specific constructions), and, along a different dimension, through the community.

Working within a structuralist framework in which the main structural axes are paradigmatic (concerned with structural choices in a certain position) and syntagmatic (concerned with structural constraints on sequences and hierarchies of units), Lehmann (1982, 1985) attempted to refine the concepts of cline and gradience. He hypothesized that a complex set of "grammaticalization parameters"⁶ all lead to grammaticalization scales in which the earlier form is fuller, freer, and more complex than the later one. In a chart reproduced as table 20.1, he identifies semantic and syntactic parameters. The lower, syntactic, half will be our only concern in the present section.

The hypothesis of shift from fuller, freer, more complex structures to shorter, more bonded, simpler ones (e.g., lexeme > affix) is an empirically testable one and has rightly been challenged (e.g., by Jeffers and Zwicky 1980; Joseph and Janda 1988; Herring 1991; Nichols and Timberlake 1991; Ramat 1992; Harris and Campbell 1995; Janda 1995, 2001). Many of the challenges relate to cliticization of former affixes and the freeing up of former clitics. Examples of the latter are the decliticization of the Estonian emphatic clitic *-p* as the relatively free particle *ep* (Campbell 1991) and of the Japanese clause-final concessive subordinator *-ga* to a clause-initial adverb (Matsumoto 1988). Particularly open to challenge has been the hypothesis of reduction in structural scope proposed by Lehmann. According to this hypothesis, grammaticalizing items have scope over smaller and smaller grammatical units. If this hypothesis is correct, sentence adverbs should become clause-internal adverbs, and complementizers

(which have scope over clauses) should become prepositions (which have scope over NPs). However, as we will see, this is not always (or even generally) the case. I will propose that although the structural reductions, the condensations, coalescences, and fixations, that Lehmann highlights are strong and viable tendencies in changes that lead to certain new form–function relationships, such as case and tense-aspect-modality, they cannot be generalized to all domains of grammatical function. They should not be used as gatekeepers to exclude from grammaticalization morphosyntactic developments that are similar in other respects to case and temporal markers (see Tabor and Traugott 1998).

1.2 *Semantic-pragmatic issues*

1.2.1 *The discourse > syntax model*

A different line of research within the domain of (morpho)syntactic change focused on what were considered to be the discourse origins of grammaticalization. The foremost proponent of this theory was Givón, who proposed the unidirectional cline:

- (3) discourse > syntax > morphology > morphophonemics > zero (Givón 1979: 209)

Reminiscent of Meillet's (1912) suggestion that word order can shift from relatively free, discourse-motivated word order to subject–predicate syntax, this model was designed to characterize such phenomena as: topic clause > relative clause; finite clause > non-finite complementation; topic > subject; serial verbs > case markers; lexical verb > auxiliary > tense-aspect-modality inflection. Probably more influential than any other statement about grammaticalization since Meillet's, this characterization brought together a number of very different processes, and a number of different domains of language study. Givón was interested in introducing pragmatics into the study of syntactic change and in exploring possible parallels between language change and the observation that loose, largely independent (paratactic) configurations give way over time to tighter, largely dependent (hypotactic) configurations in child language acquisition and the development of creoles out of pidgins. These putative parallels have, however, proved largely illusory (see Slobin 1994 on the lack of parallels between child language acquisition and language change, and Harris and Campbell 1995: ch. 10 on problems with the hypothesis of parataxis > hypotaxis).

Proponents of the discourse > grammaticalization model in general appear to believe either that grammar does not exist *a priori* and is always emerging (e.g., Hopper 1987) or that discourse is somehow chaotic and structurally unconnected with grammar (e.g., Lehmann 1982).

The conceptual problem with the perspective proposed by the emergent grammar hypothesis is that, while it is true that language systems are continually

changing, nevertheless, local changes leading to grammaticalization appear always to involve already extant structures and patterns that in use over time give rise to new structures (at least for the items in question, if not for the grammar). These new structures coexist with the older ones in a process that Hopper (1991) has called “layering.” Some of these new structures may be more tightly bonded, but they are not always so. What is predictable, on a probabilistic basis, is the new grammatical function, based on older pragmatic possibilities allowed by the already available structure.

The conceptual problem with the perspective that grammatical phenomena that serve interface functions with discourse are somehow “outside of” grammar is that the exemplars given typically entail structures that have to be accounted for in contemporary grammatical theory, even the most “formal” kind, because they occupy syntactic positions (an exception is the innovation of clausal dependency structures, which may be limited to stable pidgins and early creoles only, since other known languages have syntactic dependency⁷). Consider, for example, the claim that with respect to the colloquial French expression:

- (4) Jean, je l’ai vu hier
 “John, I saw him yesterday”

one may say “that we are here at a level where syntax does not yet govern, where the discourse is structured only by the rules of functional sentence perspective” (Lehmann 1982: 113). Lehmann is here discussing the development of new word order patterns in French (for a detailed study, see Lambrecht 1981). However, any formal syntax needs to account for the adjunct position occupied in (4) by *Jean*, given the presence of a resumptive clitic pronoun *l-*, which is subject to a binding principle that is the syntactic correlate of coreference. In other words, syntax does govern in (4) (and of course it governed prior to the development of the new construction!). More significantly, an adjunct focus position, and an adjunct topic position preceding it, have been argued by Hale (1987), Kiparsky (1995a), and others to go back to early Indo-European.

1.2.2 *The hypothesis of semantic and pragmatic weakening*

A further unidirectional proposal concerning the semantic-pragmatic aspects of grammaticalization has been that complex bundles of semantic features are reduced. This is characterized by Lehmann in the first parameter of table 20.1 as “attrition” of semantic “integrity.” A slightly different formulation refers to loss of semantic complexity: “linguistic units lose in semantic complexity [and] pragmatic significance” (Heine and Reh 1984: 15). With regard to semantic properties of the form–function pairs involved in grammaticalization, there is usually reduction in the particular semantic concrete referentialities of the lexeme involved, a phenomenon known since Gabelentz’s and Grimm’s work in the nineteenth century as “bleaching” (German *verblässen*). There is also a change in the pragmatic characteristics of the pairs. However, as will be discussed

below, the hypotheses of reduction in semantic complexity and of pragmatic weakening are deeply problematic.

The proposal that semantic complexity (as opposed to concrete semantic referentiality) reduces has been challenged in the last few years by a highly productive research model: that of cognitive mappings from one semantic domain to another (see especially Sweetser 1990), or of metaphorical transfer (e.g., Claudi and Heine 1986; Heine et al. 1991; Heine, this volume: section 5, in which semantic and pragmatic paths of grammaticalization are proposed). Sweetser is concerned to show that meaning change is not arbitrary, and that “[s]ynchronic polysemy and historical change of meaning really supply the same data” in different ways (1990: 9). Her study is of modals like *must*, *may*, connectives like *and*, *but*, and concessive (*even-if*) conditionals. Drawing on Talmy’s (1988) hypothesis that modal meanings can be understood in terms of force–dynamic relationships that oppose elements to each other, Sweetser proposes that the root modal (or “deontic,” obligation) meanings:

can be extended metaphorically from the “real” (sociophysical) world to the epistemic world. In the real world, the *must* in a sentence such as “John must go to all the department parties” is taken as indicating a *real-world force* . . . which compels the *subject* of the sentence . . . *to do the action* . . . expressed in the sentence. In the epistemic world . . . the *must* is taken as indicating an *epistemic force* applied by some *body of premises* . . . which compels the *speaker* (or people in general) to reach the *conclusion* embodied in the sentence. (Sweetser 1990: 64; italics original)

She further identifies a third metaphorical domain, that of the speech-act where the force applies in the world of conversational interaction, as in *The speech must talk about Reagan as if he were a nice guy* (ibid.: 72). One approach to the observation that in English (and many other languages) an epistemic meaning arises out of a deontic one (see, e.g., Shepherd 1982; Traugott 1989; Bybee et al. 1994) could be simply to think of the deontic meaning weakening to the epistemic meaning. However, an interesting consequence of Sweetser’s proposal can be inferred to be that even if there is loss of concrete specificity (bleaching) there is no loss of semantic complexity (the sense of obligation remains, and is simply transferred to another world). The frames for the obligation change, but the “bundle of features” is not reduced. Likewise, a theory that meanings are transferred from one domain to another in grammaticalization chains such as:

- (5) PERSON > OBJECT > ACTIVITY > SPACE > TIME > QUALITY (Heine et al. 1991: 48; Heine, this volume)

also suggests that reduction in semantic complexity is not criterial.

These approaches to semantic change in grammaticalization focus on cognitive structures, on sources and targets of change. Sweetser emphasizes schemas, relational templates that structure thought. Similarly, Heine (1993: 31) highlights the importance of “event schemas” such as “X is at Y, X moves to/from Y, X does Y, X wants Y” etc. as sources for auxiliaries (see also Heine, this

volume: section 6, where he cites some examples of such schemas, e.g., the volition schema (X wants Y) and the goal schema (X has Y)). Relational as these are, they do not privilege context, and so are in part conceptually associated with the lexeme > grammar approach to grammaticalization.

In Traugott (1982) the seeds of a different kind of unidirectional hypothesis were put forward regarding semantic-pragmatic change. The focus here was on ways in which grammaticalization involves pragmatic strengthening (not weakening), specifically that there is a strong cross-linguistic tendency for the semantics-pragmatics of grammaticalization to involve the shift:

(6) propositional (> textual) > expressive meaning (Traugott 1982: 256)

According to this hypothesis, some of the original, often relatively concrete, semantic components of a lexeme may be generalized or even lost, but more abstract ones may be gained, as well as new pragmatic meanings. For example, the compositional meaning 'for the extent of time that' of the Old English construction *þa hwile þe* was semantically and pragmatically reanalyzed as a concessive 'although' in the seventeenth century. This involved the weakening of the meaning 'time,' but it also involved strengthening of the speaker's pragmatic viewpoint, since 'although' expresses the pragmatics of counter-expectation, a conceptual structure entirely dependent on the mental models that speakers assume (Traugott and König 1991). Recent work has confirmed that increase in pragmatic force is frequently found in grammaticalization, most often, but not necessarily, in its early stages (see Sweetser 1988; Traugott 1988, 1989; Abraham 1991; Bybee et al. 1994; Company 1995; Nikiforidou 1996; Bybee, this volume).

The hypothesis in (6) proved to be generally correct, but "textual" was ambiguous in unfortunate ways⁸ between:

- i (what was originally intended) the development of meanings signaling cohesion, especially intra-clausal truth-conditional connections made by the same speaker in the same turn;
- ii (what later came to be of focal interest among practitioners of pragmatics and discourse analysis) the development of meanings signaling strategic interaction.

Consider, for example, the difference between *so* as a cohesive causal connective (e.g., *Bill insulted Mary, so she left*), as a marker of the speaker's inferential conclusion (*There's \$5 in my wallet, so I didn't spend all my money after all!*), and as a turn-taker, signaling the speaker's attempt to reorient the flow of conversation (see, e.g., Blakemore 1988).

(6) has been reformulated as three tendencies involving semantic and pragmatic strengthening (Traugott 1989), of which a tendency toward subjectification is the most important for the discussion to follow. Subjectification in grammaticalization is "the development of a grammatically identifiable expression of

speaker belief or speaker attitude to what is said" (Traugott 1995a: 32).⁹ Like the original hypothesis in (6), subjectification is not limited to grammaticalization but can also be found in lexical change, for example, in such well-known cases of pejoration as *boor* 'countryman, farmer' > 'crude person.'

Pragmatic strengthening in general, and subjectification in particular, arise out of the cognitive and communicative pragmatics of speaker–hearer interactions and discourse practices (see Langacker 1977; Du Bois 1985; Hagège 1993; among others). The assumption is that speakers draw on knowledge not only of linguistic structure, but also of information packaging and retrieval, and on conversational heuristics of the kind: "Say no more than you must and mean more thereby" (Levinson 1983, 1995; Horn 1984). Over time speakers may begin to use conversational implicatures strategically, that is, to invite uptake on conversational meanings; these may become conventionalized, and eventually semanticized; in other words, a new polysemy may develop (e.g., *since* 'from the time that' > 'because'). This process may be called "invited inferencing," a term which originates with Geis and Zwicky (1971). It is a term that highlights the interactive nature of language use: speakers/writers can invite addressees/readers to let implicatures go through.¹⁰ Invited inferencing is a kind of conceptual metonymy within the speech chain (see Geis and Zwicky 1971; Dahl 1985; Brinton 1988; Traugott and König 1991), since it is primarily associative in character, being derived from the uses to which interlocutors put linear sequences of utterances and associations in context. In the case of subjectification, the new polysemies are those in which the speaker's perspective is an essential element. Typically the new polysemy is more abstract (see Pagliuca 1994: ix on the path of a "lexical construction . . . away from its original specific and concrete reference and toward increasingly general and abstract reference"; also Dasher 1995 on grammaticalization as a shift from referential to non-referential meaning).

Figure 20.1 provides a schematic model of the process of meaning change in grammaticalization. It is to be interpreted as follows, using the example of the well-known development of *be going to* (see Pérez 1990; Hopper and Traugott 1993; Tabor 1994b; Bybee, this volume; for examples and discussion). At time T_1 there is a construction CST_1 with a meaning M_1 . This form–function pair is available for use in discourse, which is negotiated between speakers and addressees with reference to analogies, metaphors, and invited conversational inferences. *Be going to V* in Middle English (T_1 for this construction) meant only 'be in motion for the purpose of acting in a certain way.' This construction, and other purposive constructions like it, had presumably long been associated with inferences, among them the inference that the subject intended the future occurrence of the purposed action. By late Middle English we find a potential example of *be going to* in the non-motion sense of planned future action. Such examples increase in frequency in the sixteenth century.

We can hypothesize that the implicature came to be invoked (and hence interpreted) more frequently than before, that is, by earlier Early Modern English (T_2) it had come to be regarded as salient in the community of speakers. As Bybee

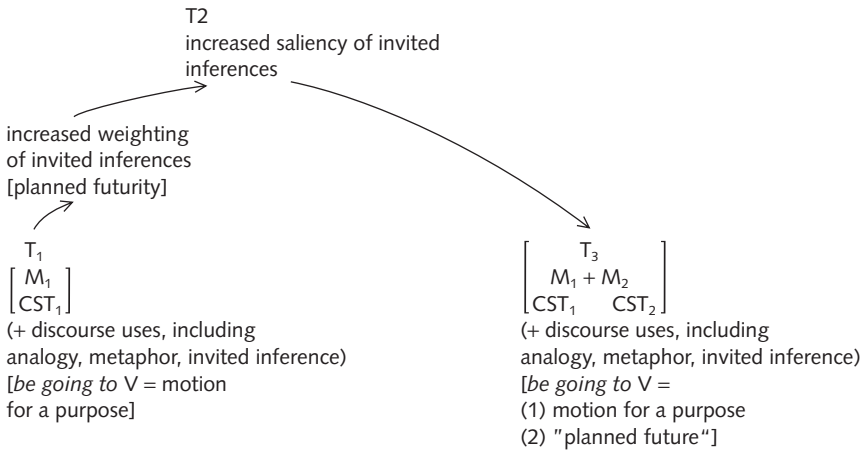

Figure 20.1 Model of meaning-change in grammaticalization

et al. (1994: 297) point out, linguistic “context is all-important” in the development of motion verbs into future markers. They say that cross-linguistically this development occurs only when there is an allative component (“movement toward”) and when the movement is in progress (“progressive, present, or imperfective”) (ibid.: 168). The precise syntactic structure of the *be going to* construction therefore appears to have been crucial for the implicature of planned futurity to become salient.

After further extended use the conventionalized implicatures became semanticized¹¹ at T₃ (the seventeenth century) and *be going to* acquired a new polysemy as a “future” marker, allowing it to occur with non-activity verbs, and to coexist with the original “be in motion for the purpose of” construction, which occurs only with activity verbs (compare unambiguous *She is going to like New York* with ambiguous *She is going to visit Jean*). Structurally, this means that *be going to* now had a new conceptual meaning M₂, paired with a new morphosyntactic construction (CST₂); however, the phonological string probably remained the same. This new CST₂-M₂ pairing became dissociated from the older motion verb construction, and a new phonological form arose permitting *gonna* (attested from the beginning of the twentieth century).

The claim that meanings change before new syntactic contexts become available is a controversial one. It was originally proposed in Fleischman (1982) in connection with the development of modal meanings prior to structural grammaticalization of verbs like *habere* in Latin to futures, and in Brinton (1988) in connection with the development of aspect and aspectualizers in English. Approaches from formal syntax typically hypothesize dependency of semantic change on prior syntactic reanalysis (see, for example, Warner 1993: 196–7). However, a close investigation of historical texts points repeatedly to the

occurrence of meaning change before syntactic reanalysis is possible. The examples below confirm this.

2 Some Examples of Grammaticalization

2.1 From nominal complex¹² to clause connective

Among the best-known changes in grammaticalization are many that involve an original locative, including the development of case, temporals, and clause connectives (see Lehmann 1982; Heine and Reh 1984; Heine et al. 1993; Hopper and Traugott 1993; Lord 1993; Svorou 1993; and several papers in Pagliuca 1994).

A fairly uncontroversial example is provided by *instead of* in its early stages. Schwenter and Traugott (1995) investigates the semantic development of the complex prepositional phrase *in stead of* and its partial synonyms *in place/lieu of* to express the relation of substitution. All three originally meant literally 'in place of' in the history of English. By "substitution" is meant the process whereby an entity X replaces another entity Y, where Y is a token of a certain type, and X is a new token of the same type. On a conceptual level, substitution involves the "moving out" of Y followed by the "moving in" of X. Typically, X and Y are represented syntactically as noun phrases, such that "X (an NP) *in stead/place/lieu of* Y (an NP)" (Schwenter and Traugott 1995: 245–6).

The ancestor of *instead of* appears in early Old English (OE) in the construction *in stede* 'place' + genitival NP.¹³ The old noun *stede* as in (7) survives as a derivative suffix as in *homestead*; otherwise it has become largely fixed in indivisible phrases of which by far the most common is *instead of*.

An example of locative *stede* in OE follows (see abbreviations on pp. 525–6 for full details of sources):

- (7) ær hie mon to ðæm *stede* brohte ðe hie on standan
 before them one to that place brought that they on stand:INF
 scoldon
 were-expected
 "before they were brought to the place where they [the stones for Solomon's temple] were expected to stand" (c.880 CP: 253)

Stede is also used in the sense of 'rank, position, function, job,' as terms for location often are (cf. the words *position*, *rank* themselves):

- (8) Gif ealle menn on worulde rice wæron, ðonne næfde
 If all men in world rich were, then neg:have:SUBJ
 seo mildheortnyss nænne *stede*
 that compassion no place
 "If everyone in the world were rich, there would be no place/role for compassion" (c.1000 ÆCHom 11, 7)

The “role” sense of *stede* is semantically an abstract, non-physical one. The place in which compassion exists is synchronically¹⁴ conceived metaphorically: compassion occupies a space in the mental world of values or functions.

There are a few examples from later OE of the substitutive *stede*. It is used in the sense of substituting one person for another in a role (that of disciple in (9)):

- (9) Mathias bodode on Iudea lande se þe wæs gecoren on Iudan stede
 Mathias preached in Judea land who was chosen in Judas’ place
 “Mathias, who was chosen in Judas’ place, preached in the land of Judea”
 (c.1000 Ælfric’s Letter to Sigeward: 60)

This too is an abstract sense of place: the place out of which Judas is “moved” and into which Mathias is put is the figurative space of “rank” for preachers.

By the later Middle English (ME) period we begin to find the substitutive construction extended from persons to concrete objects and abstract (nominalized) actions:

- (10) For many a man so hard is of his herte,
 He may nat wepe, although hym soore smerte.
 Therefore *in stede of* wepyng and preyeres
 Men moote yeve silver to the povre freres.
 “For many a man is so hard of heart that he cannot weep although his heart hurts. Therefore instead of weeping and prayers, people should give silver to the poor priests.” (c.1388 Chaucer, Prol. Cant. Tales: 27)

In the Early Modern English (EMdE) period the contexts have been expanded to *-ing* complements (gerunds):

- (11) [of medicines] have a great care of tampering that way, least *instead of* preventing you draw on diseases. (1693 Locke, Education: 48)

Most recently it has been generalized to finite clauses:

- (12) “Mr. Rose,” US District Judge Arthur Spiegel politely asked the man called “Pete” by most people, “are you in pain because of your leg? If so, you can sit *instead of* stand.” (July 19, 1990, United Press International)

Examples (10) from later ME and (11) from EMdE involve topicalization of the substitutive phrase, as do many of the examples in the Helsinki Corpus. The hypothesis is that the grammaticalization of *instead of* to a connective introducing *-ing* complements could not have occurred without the prior semantic change from locative to substitutive expression, and fronting (syntactic “topicalization”) of the substitutive construction to clause-initial position when it has been generalized to non-human contexts.

The changes shown in (9)–(11) are standard examples of early grammaticalization in the sense that a lexeme (*stead*) has become decategorialized and the complex preposition arising from it is a fixed formula (Ramat 1992). However, the development of the connective in (12) challenges the view of structural grammaticalization characterized by Lehmann in table 20.1, since it involves expansion in syntactic scope.

The theoretical implications of this last development will be discussed in section 3. Suffice it here to propose that *instead (of)* is an instance of grammaticalization in which the following semantic and structural changes took place:

- i *Semantic change.* The substitution meaning is logically, and empirically, prior to the development of the connective. It is also highly constrained – it occurs at first only with reference to persons of a certain identifiable standing or rank. The development of the substitution meaning is semantic-pragmatic only; structural change takes place later when *instead of* begins to introduce *-ing* complements and finite clauses, in other words, event-structures that are clausal rather than purely nominal. Later there was:
- ii *Decategorialization.* Like many other complex prepositions such as locative *in back of* (Heine et al. 1991) or degree modifier *sort of/kind of* (Tabor 1994b), the construction that eventually grammaticalized involved decategorialization of the nominal (i.e., it could no longer occur with modifiers like determiners or quantifiers) in the context of the preceding preposition *in* and the following *of*.
- iii *Reanalysis.* As in the case of many other complex prepositions, the construction that emerged due to grammaticalization seems to have involved reanalysis of a syntactic group of the type [P – NP [P – NP]] > [P – N – P] NP].¹⁵ This was presumably enabled by a phonological phrase rather than a syntactic one – note phonological and lexical parallels to *for* (= *instead of*) and *quite/rather* (= *sort of*). This resulted in morphosyntactic bonding of the internal constituents of the construction: *instead of* became a fixed expression with non-compositional constituents. Later, there was:
- iv *Generalization, scope increase.* *Instead of* generalized not only to more and more classes of nouns, but also to *-ing* complements and later finite clauses. This was accompanied by increase in structural scope. In other words, while the internal structure of *instead of* became fixed and entirely constrained, the unit itself came to be less constrained syntactically.

2.2 From nominal complex to discourse marker

This section concerns the development of a class of forms usually known as discourse markers (DMs). DMs are items that “bracket” units of discourse (Schiffrin 1987). In a more restrictive definition of DMs building on Schiffrin’s

subclass of “discourse deictics,” Fraser has defined DMs as the class of pragmatic markers that “signal a comment specifying the type of sequential discourse relationship that holds between the current utterance – the utterance of which the discourse marker is a part – and the prior discourse” (Fraser 1988: 21–2).

In Modern English (MdE) many DMs in Fraser’s sense may be disjunctive (Fraser 1988, 1990). Many occur clause-initially, where they carry a special intonational contour in speech, including an intonational peak and a breath unit (see Allerton and Cruttendon 1974 on British English; Ferrara 1997 on uses of *anyway* in Texas English). They may be, and indeed usually are, polysemous with items of the same form but with different functions (see Jackendoff 1972; Ernst 1984 on meanings associated with adverbs and adverbial phrases in different positions within the clause). Schiffrin, for example, contrasts anaphoric temporal adverb *then* as in:

(13) [referring to the year 1906] How old were you *then*? (Schiffrin 1987: 249)

with the “discourse deictic” marker *then* which serves to mark a speaker’s progression through discourse time:¹⁶

(14) [referring to number of people in a team] The two couples, yeh. And *then* the kids have their own team. (Schiffrin 1987: 253)

Adverbs and adverbial phrases in clause-initial position are usually known as sentence adverbs. Where we have access to their historical development, we find they typically start out as predicate adverbs. Many are in origin temporal adverbs, such as *then, now, anon* (Brinton 1996), or manner adverbs (see Hanson 1987 on the development of modal adverbs like *probably, possibly*; Powell 1992 on the development of “stance” adverbs, e.g., *actually, loosely, precisely, really, roughly speaking*, all of which shift from manner adverb > sentence adverb). Some of them develop into adverbs with DM function.

A short sketch of *indeed* shows that *deed* was (and of course still is) a lexical noun which could be modified by demonstratives, adjectives, etc. By early ME it was routinized as a bare prepositional phrase (PP) as in (15):

(15) Al þat þou hauest her bifore I-do, In þohut, in speche, and
 All that thou hast here before done, in thought, in speech, and
in dede, . . . Ich þe forzeue
 in action, . . . I thee forgive
 “I forgive thee for all that you have done heretofore, in thought, in
 speech, and in action” (c.1300 Fox and Wolf: 34)

In this construction it came to be endowed with epistemic modal and weakly subjective meanings, as in:

- (16) for þe ende *in dede* schulde come aftur þat schulde be
 for the end in deed should come after that should be
 euen as þe furste sizt
 even as the first sight
 “for the end should come after, that should be like the first sight” (c.1380
 Engl. Wycliffite Sermons: 1589)

By the beginning of the EMdE period it is occasionally found in clause-initial post-Complementizer position as a contrastive adverb refuting an earlier claim or hypothesis. Structurally it serves a sentence adverb function, and pragmatically it focuses the truth of an unexpected predicate:

- (17) they [teachers] somtyme purposely suffring [allowing] the more noble children to vainquysshe, and, as it were, gyuying to them place and soueraintie, though *in dede* the inferiour chyldren haue more lernyng (1531 Governor: 21 [HC])

By the seventeenth century we find it in clause-initial, pre-Complementizer position with meanings involving elaboration and clarification of discourse intent, in other words full DM function:¹⁷

- (18) thereby [the flea is] inabled to walk very securely both on the skin and hair; and *indeed* this contrivance of the feet is very curious, for performing both these requisite motions (1665 Micrographia: 135)

Just like *instead* and *indeed*, *anyway* has its origins in a phrase with a full lexical noun, in this case *way* ‘path.’ This noun could occur as an argument or in a clause-internal adverbial phrase as in:

- (19) a. Sche wolde zet excusyn hir yf sche myth in *any way*, and þerfor sche seyde
 “She still wanted to excuse herself if she could in any way, and therefore she said” (c.1438 Kempe: 1227)
 b. He schall haue accusars aboue hym, wythyn hym, on aythyr syde hym, and vndyr hym, þat he schall *no way* scape
 “he shall have accusers above him, within him, on either side of him, and under him, so that he shall by no way escape” (before 1500 Mirk, Festial: 4)

(19a) requires a manner reading, at least for a modern audience. *No way* in (19b) can literally mean ‘by no path,’ but it can also be understood more abstractly as ‘in no manner’ or ‘to no extent.’

By the late sixteenth century an unambiguous manner/extent adverbial use begins to be found in the Helsinki Corpus without the locative preposition *in*,

still in negative, conditional, or other irrealis contexts as in (20a). By the end of the EMdE period we find an example in a realis context (20b):

- (20) a. and moreover so, that they bee not, *any way* overloaded or discouraged, nor yet indangered, by the overcharging of their wits and memories (1627 Brinsley, *Ludus Literarius*: 12)
- b. The Generation of all things, and every Progression of changeable Natures, and all things which are *any way* moved, receive their Causes, Order and Forms out of the Stability or Constancy of the Divine Mind. (1695 Preston, *Boethius*: 191)

The beginnings of an adversative (concessive) use meaning ‘nonetheless’ appear to have arisen in the early part of the eighteenth century out of the implicature that to do something (*in any way (at all)*) is to do it despite normal expectation or reason:

- (21) This is certain, that whereas we behold the selfish Actions of others, with Indifference at best, we see something amiable in every Action which flows from kind Affections or Passions toward others; if they be conducted by Prudence, so as *any way* to attain their End. (1726 Hutcheson, *Enquiry*: 155)

Once semanticized, this adversative *anyway* often occurs clause-finally, as in:

- (22) The tape shows Barry picking up the crack pipe and asking how it worked, adding “I never done it before.” But when he received no directions, he lit up *anyway* and inhaled the drug (July 2, 1990, United Press International)

By the middle of the nineteenth century clause-initial *anyway* comes to be used as a DM elaborating and justifying what has been said:

- (23) It’s queer; very queer; and he’s queer too; aye, take him fore and aft, he’s about the queerest old man Stubb ever sailed with. How he flashed at me! – his eyes like powder-pans! is he mad? *Anyway* there’s something on his mind, as sure as there must be something on a deck when it cracks. (1851 Melville, *Moby Dick*: 125)

Like other DMs, it may co-occur with an earlier polysemy:

- (24) *Anyway* [DM] and so then we ended up sleeping under there *anyway* [adversative] and I only scared two people. (Ferrara 1997: 353; glosses added)

The development of *indeed* and *anyway* illustrate the same first three general points as *instead* (of):

- i *Semantic change.* Epistemic meanings of *indeed* were necessary before fronting to clause-initial position was possible; manner adverbial meanings were necessary for *anyway* before it could be used clause-initially.
- ii *Decategorialization.* The lexical nouns were decategorialized in specific contexts: *deed* after the preposition *in*, and *way* after *any* in negative or irrealis contexts.
- iii *Reanalysis.* The decategorialization involved morphosyntactic reanalysis in terms of the internal structure of the PP (internal bonding of the formerly independent elements *in + deed*, *any + way*). This was followed by a further reanalysis of adverbial function, which can be considered to be a case of:
 - iv *Generalization, increase in structural scope.* Whereas the internal structure of the adverbials became more fixed, the syntactic constraints were loosened. Sentence adverbial, contrastive *indeed* occurs after a complementizer (*if indeed they want to go, . . .*), discourse marker *indeed* precedes it (*indeed, if they want to go . . .*).

3 Implications for a Theory of Grammaticalization

Strict adherence to criteria such as have been laid out in Lehmann (1982) would exclude many of the developments discussed here from the domain of grammaticalization. In particular, the development of clause-internal adversative and manner adverb > sentence adverb > clause-external adverb with discourse marker function (*indeed, anyway*) would appear to be excluded from grammaticalization because they violate Lehmann's criteria of increased bonding and syntactic scope reduction (table 20.1).

Indeed, Fraser (1988: 22) refers to DMs as "lexical adjuncts." In connection with English *y'know*, and Swedish '*ba* 'only' from *bara* 'barely' ("discourse markers" in the broad sense initially proposed by Schiffrin 1987), Erman and Kotsinas (1993) have suggested that rather than grammaticalization, "pragmaticalization" has taken place. Their reasons are based on the claims that DMs are restricted to speech, and that a grammatical stage between lexeme and DM is not necessary. However, evidence in section 2.2 shows that both arguments fail. *Indeed* clearly developed in the context of writing. Even if academic writing of the sixteenth to eighteenth centuries did not have the requirement of "objectivity" associated with it since the nineteenth century, it was still relatively formal, and of a literate register associated with expository prose. Furthermore, *indeed, anyway, and instead* of are classic cases of

decategorialization, since PP had to be frozen as P + bare N before the epistemic adverb or substitutive complex preposition could arise. A third approach has been suggested by Vincent et al. (1993) in their synchronic study of French DMs and back-channelers. They suggest the term "postgrammaticalization," but despite the term, no earlier, historically more grammatical stage seems to be posited. Rather, the term seems to mean "pragmaticalization," and availability on an "extra-grammatical" level. Whatever the grammatical status of back-channelers, DMs clearly are not extra-grammatical. They are regularly included in discussions of sentence adverbs (cf. Jackendoff 1972; Ernst 1984). Even though they do not carry primarily (or even any) truth-functional meaning, and have scope over far more than the sentence, in constituent structure terms they are part of the structure of the sentence and have been in generally similar ways from early Indo-European times on.

For all these reasons, and their role in contributing to the (relatively) closed class components of the grammar, it is appropriate to consider the development of clause connectives like *instead of* and of DMs like *indeed*, *anyway* as cases of grammaticalization (see Tabor and Traugott 1998). Indeed, Schiffrin (1992: 363) hypothesizes that DMs arise from grammaticalization processes, and arguments similar to those I have given above have been made with respect to pragmatic markers of various types in English by Brinton (1996), in Swedish by Lehti-Eklund (1990), and for adversatives in Japanese by Matsumoto (1988) and Onodera (1995). Further supporting evidence is provided by some languages other than English, since cross-linguistically equivalents to DMs do not necessarily become adjuncts, and therefore do not necessarily violate the criterion of bondedness as clearly as in English. For example, similar items may be clitics (see Brody 1989 for discussion of sentence-final clitics meaning 'anyway' (contrastive and elaborative), in Tojolabal Mayan), many of them occurring in "second position" (see Kaisse 1982). To treat the development of DMs as cases of something other than grammaticalization would be to obscure their similarities with the more canonical clines.

If we allow our theory of grammar to include elements that occupy syntactic positions and have syntactic constraints, even though they may have principally pragmatic functions, as do the DMs discussed here, the data in section 2 (especially 2.2) become the legitimate object of study in terms of syntactic change. It becomes an equally legitimate object of study in terms of grammaticalization if we accept that different parts of the grammar have different purposes, and therefore elements that do the work associated with discourse management may not be subject to the same kinds of syntactic scope reduction as elements that do the work associated with, for example, case and tense. The data cease to be in any way a counterexample to grammaticalization if we focus not on lexical item > grammatical item, but on lexemes undergoing change in the context of constructions.

Early grammaticalization can therefore be seen as a complex set of correlated changes:

- (25) i structural decategorialization;
 ii shift from membership in a relatively open set to membership in a relatively closed one (i.e., from lexical category to syntactic operator category) in the context of a specific construction;
 iii bonding (erasure of morphological boundaries) within a construction;
 iv semantic and pragmatic shift from more to less referential meaning via invited inferencing.

Later grammaticalization typically also involves phonological attrition, which may result in the development of paradigmatic zero (Bybee 1994).

As suggested in section 1.2, on this view grammaticalization arises out of reweightings of certain inferences in frequently repeated use, in the primarily linear, syntagmatic negotiation of meanings between speaker and addressee. Discourse use is an essential ingredient in the processes that may lead to change, but the change is not from discourse > syntax but rather, for the string in question, from already extant syntax via pragmatic use in discourse > syntax with a different, operator-like function. One factor to note here is that none of the examples discussed produces new syntax in terms of a new abstract structure or a new hierarchic relationship. In every case what we have is the recruitment of morphosyntactic strings into already extant morphosyntactic structures.¹⁸

I have argued that the contexts for recruitment involve constructions and increased saliency of certain implicatures associated with them in frequently repeated use, especially in the linear, syntagmatic negotiation of meanings between speaker and addressee. If we consider the various developments discussed above from the perspective of metaphors or cognitive mappings pertaining to lexical items as suggested in Heine et al. (1991), we find substantial consistencies with subparts of the grammaticalization chain "PERSON > OBJECT > ACTIVITY > SPACE > TIME > QUALITY," cited above as (5). *Way* 'path' (ultimately from 'carry, journey') and *stead* 'place' (ultimately from 'space that can be stood on') originate etymologically in objects or activities that relate to humans. *Any way* and *instead* both come to express spatial relations and "quality." However, the syntactic constraints, most especially restriction to specific syntactic environments such as *in* or *any*, are not captured by such schemas. Nor are the pragmatic and syntactic differences among "qualities," such as sentence adverb versus discourse marker function. Chains of the kind cited above can be used to predict the lexical fields from which and into which future instances of grammaticalization may be recruited. But absent information on the contexts for change, such models highlight macro-level sources and targets, in other words, synchronic structures before and after the process of grammaticalization has set in, rather than the process itself.

Because the precise syntactic structure of the original construction as well as the particular inferences from it are so crucial in enabling grammaticalization,

it follows that, as Bybee et al. (1994: 11) point out, it cannot be the case that “one source concept can give rise to more than one grammatical category” (Heine et al. 1991: 338). Different contextual sources will give rise to different instances of grammaticalization.

Another point to be noted in connection with the approach adopted here is that focusing on lexical items in the context of constructions leads us ideally to consider not only one-dimensional chains such as PERSON > OBJECT . . . , but a whole range of similar constructions that may function in a multi-dimensional “attractor set” that motivates and constrains particular changes. For example, the history of *anyway* is presumably inextricably tied up with that of *anyways*, and especially *anyhow*. Focus on autonomous lexical items obscures such interconnections.

4 Conclusion

I have argued that paying more attention to the morphosyntactic (and pragmatic) contexts in which lexical items become grammaticalized than has been usual in the past can open up new perspectives and areas of research in grammaticalization.

A focus on strings or constructions rather than lexical items alone might appear to extend the domain of grammaticalization too far. It is true that little will be excluded from study if we think of “grammaticalization” as an approach, a way of construing the data, with focus on interactions between structure and use and on gradualness (in the sense discussed in section 1.1). But grammaticalization is not coterminous with change. Phonological changes with no morphological effects will be excluded, as will semantic changes involved in lexicalization, for example, in the shift from one major category to another (as in the case of N > V, e.g., *Doctors please badge the door*), or word formation and compounding (as in the case of *herstory* and *white-board*). An interesting area for investigation in this regard is that of idioms of the type discussed in Nunberg et al. (1994). Although conventionalized, fixed, and subjectivized, idioms like *corral the strays*, *make a note of*, *make a clean breast of*, and *take hold of* serve major, not minor, category functions, and cannot be said to have undergone grammaticalization. Likewise, insofar as “grammaticalization” refers to a type of change, rather than an approach, it is not coterminous with morphosyntactic change. Rather, it is:

- (26) The process whereby lexical material in highly constrained pragmatic and morphosyntactic contexts is assigned grammatical function, and once grammatical, is assigned increasingly grammatical, operator-like function.

ACKNOWLEDGMENT

An earlier version of parts of this chapter was presented in Traugott (1995b). I have profited from comments by many people, including Joan Bybee, Richard Dasher, Mark Durie, Charles Fillmore, Bernd Heine, Richard Janda, Roger Lass, Whitney Tabor, and Arnold Zwicky. I am especially indebted to Norma Mendoza-Denton, whose research on *concerning NP* constructions (see Mendoza-Denton 1998) started me thinking about migration of adverbials to the left margin of the clause in English, and to Scott Schwenter, for whose insightful comments, bibliographical suggestions, and unflagging interest in pushing on the frontiers of grammaticalization theory I

am truly grateful. I am, of course, solely responsible for any errors of fact or interpretation.

The main databases used are: *The Helsinki Corpus of the English Language* (see, e.g., Rissanen et al. 1993); *The Dictionary of Old English Corpus in Electronic Form. University of Toronto: Dictionary of Old English Project*; the on-line *Oxford English Dictionary*; top stories from *United Press International* 1990–2. Stanford Academic Text Services, and Michelle Murray in the Department of Linguistics, Stanford University, made access to these and other computerized corpora possible.

NOTES

- 1 “Lexical item” is a theoretical construct and therefore theory dependent. Here the term is intended to designate a member of an open class that is associated with prototypical features of that class (e.g., for nouns: demonstratives, quantifiers, number, gender and case; for verbs: tense, aspect and mood, etc.).
- 2 “The passage of an autonomous word into the role of grammatical element . . . the attribution of grammatical character to a formerly autonomous word.”
- 3 However, see Lehmann (1992), Claudi (1994), and Heine (this volume) for recent discussions of word order in terms of grammaticalization.
- 4 The periods of English are as follows: Old English (OE) c.700–1150, Middle English (ME) c.1150–1500, Early Modern English (EMdE) c.1500–1750, Modern English (MdE) c.1750–present.
- 5 There are a few exceptions, such as *up* and *down* in English, which can be used as lexical nouns and verbs.
- 6 For Lehmann these are what might be considered grammatical characteristics, not “parameters” in the generative sense of that term.
- 7 Most languages show clines of complex clause structure from adjunction to subordination: see Foley and van Valin (1984); Haiman and Thompson (1988); Harris and Campbell (1995); among others. Syntax needs to account for the whole range of dependencies.
- 8 See especially Romaine and Lange (1991); Powell (1992); Brinton (1996).
- 9 For a related but more restrictive view, see Langacker (1990). Some challenges to the hypothesis of unidirectionality of subjectification are suggested in Herring (1991) and Schwenter (1994).
- 10 It also invokes speaker production, in contrast to “context-induced

- inferencing," the term preferred by Heine et al. (1991), which evokes processing by hearers.
- 11 The process of semanticization is also known as "lexicalization"; the latter term is, however, better reserved for processes leading to the development of major class members, such as nouns or verbs (see Traugott forthcoming).
 - 12 The phrase "nominal complex" is borrowed from Lehmann (1982) to cover a variety of nominal constructions, including complex Prepositional Phrases like *in stead of*.
 - 13 OE had only inflectional genitive in this construction. The obligatory replacement by *of* is independent of the semantic development of *instead of*. The spelling *instead* became common in the sixteenth century, according to the OED.
 - 14 Historically, however, the change may have come about metonymically through association of social role with assigned placement, such as seating positions.
 - 15 Crucial syntactic evidence is, however, not available for this reanalysis (Arnold Zwicky, pers. comm.)
 - 16 Enkvist and Wårvik (1987) discuss similar distinctions in the use of *þa* 'then' in OE.
 - 17 *Indeed* appears to be especially favored in expository prose. The role of text type and register in grammaticalization needs to be more fully understood. Taavitsainen (1994) discusses the role of expressions of personal involvement in various text types represented in the Helsinki Corpus, and the importance of generic conventions in change.
 - 18 New syntactic categories may, however, occasionally arise as the result of accretion of many changes, for example, the development of the syntactic category AUX in English.

21 An Approach to Semantic Change

BENJAMIN W. FORTSON IV

When changes happen to the meanings of words, we speak of *semantic change*. Meanings of words can be extended creatively (a possibility afforded by the human cognitive system), or their meanings can change through reanalysis, chiefly but not exclusively during language acquisition. Any speaker without direct access to the intent of the speakers around him or her must figure out what words mean from the contexts in which he or she encounters them. As Nerlich (1990: 181) puts it, “Words do not convey meaning in themselves, they are *invested* with meaning according to the totality of the context. They only *have* meaning in so far as they are interpreted as *meaningful*, in so far as *the hearer attributes meaning to them in context*” (emphases in original). If an interpretation of a word different from the intended interpretation is possible, and if this new interpretation is the one seized upon by the listener or learner and entered into the lexicon (“new” from the point of view of other speakers, that is), semantic change has happened. Limiting the term “semantic change” to such reinterpretations, or reanalyses, naturally and correctly excludes the everyday creative synchronic extension of meanings mentioned above (the latter not usually considered as constituting “language change”; see further below).

Textbooks in linguistics commonly list various types or categories of semantic change.¹ Although below I will be arguing that they are not very helpful for our understanding, an introductory discussion such as this one would be incomplete without taking them into account and briefly reviewing the types most commonly referred to:

- i *Metaphoric extension*. A metaphor expresses a relationship between two things based on a perceived similarity between them. When a word undergoes metaphoric extension, it gets a new referent which has some characteristic in common with the old referent. Words denoting body parts commonly undergo metaphoric extension: the *head* of an animal is its frontmost part, so one can also speak of the *head* of a line; the *head* of a person is his or her highest part, so one can speak of the *head* of a

community, the person having the highest standing. Similarly, we speak of the *foot* of a mountain, the *leg* and *back* of a chair, the *knees* of a bald cypress, being on the *heels* of victory, and the *heart* of a palm. Another cross-linguistically common metaphor is the use of verbs meaning ‘grasp, take hold of’ in the meaning ‘understand,’ as English *grasp*, *get*, German *fassen*, *ergreifen*, Mandarin *lǐng*, *huì*.

- ii *Metonymic extension*. Metonymic extension results in a word coming to have a new referent that is associated in some way with the original referent. The two referents here stand in a contiguity relationship with one another, rather than in a similarity relationship as with metaphoric change. When we say, “The *White House* issued a bulletin,” we do not mean that the actual building at 1600 Pennsylvania Avenue engaged in this action; rather, we are referring to certain people associated with that building, that is, the executive branch of the US government. The phrase *White House* thus can refer to both the physical structure and the people associated with it; this latter meaning is a result of metonymic extension. (The same is true of its counterpart behind the former Iron Curtain, the *Kremlin*.) Another example is the adjective *blue-collar*; in the first instance it referred to workers who wear blue shirts, but then came to describe a worker who does a particular type of work with which blue shirts were associated. As has often been pointed out, in order to trace the rationale for particular metonymic changes, it can be necessary to have detailed knowledge of the culture in which the language is spoken.
- iii *Broadening*. The word *dog* used to refer to a particular breed of dog, but came to be the general term for any member of the species *Canis familiaris*. This is an example of *broadening*, whereby a word that originally denoted one member of a particular set of things comes to denote more or all the members of that set. *Thing* used to refer to an assembly or council, but in time came to refer to *anything*. In modern English slang, the same development has been affecting the word *shit*, whose basic meaning ‘feces’ has broadened to become synonymous with ‘thing’ or ‘stuff’ in some contexts (*Don’t touch my shit; I’ve got a lot of shit to take care of this weekend*). If a word’s meaning becomes so vague that one is hard-pressed to ascribe any specific meaning to it anymore, it is said to have undergone *bleaching*.² *Thing* and *shit* above are both good examples. When a word’s meaning is broadened so that it loses its status as a full-content lexeme and becomes either a function word or an affix, it is said to undergo *grammaticalization*. This will be discussed in much more detail below.
- iv *Narrowing*. Narrowing is the opposite of broadening – the restriction of a word’s semantic field, resulting in the word’s applying only to a subset of the referents that it used to be applied to. *Hound* used to be the generic word for ‘dog’ (cf. German *Hund*) but nowadays refers only to a subset of possible dogs. *Meat* used to refer to ‘food’ in general, but now only to a particular kind of food. *Deer* used to be the all-purpose word for ‘wild animal,’ but now refers only to a specific kind of wild animal. The *skyline*

referred once to the horizon, but now specifically to the outline of the buildings of a large city against the sky, poking up from or in front of the horizon.³

- v *Melioration and pejoration.* These are purely subjective terms referring to cases when a word's meaning becomes either more positive (melioration or amelioration) or more negative (pejoration). Two examples of melioration from English are *nice*, which meant originally 'simple, ignorant' but now 'friendly, approachable,' and *paradise*, which in Greek originally referred to an enclosed park or pleasure-garden, but came to be used for the Garden of Eden, whence the English meaning. Pejoration affected the word *silly*, earlier 'blessed' (cf. German *selig*), as well as *mean*, whose earlier meaning 'average' has been ratcheted down to 'below average, nasty' (cf. German *gemein*, now 'common, low, vulgar' from 'common, shared').

Such is a typical textbook typology of semantic change. Many other types have been put forward, but do not concern us here.

1 Reanalysis

Traditional typologies such as the one above are problematic, as has not gone unnoticed. Typical criticisms are that some changes are not covered by any of the types proposed in the literature,⁴ and that a number of the types can be combined.⁵ These remarks are quite correct. However, they are rather beside the point, because it is my contention that the typologies themselves are beside the point. The reason is that they refer to the *results* of change;⁶ they leave entirely untouched the reanalyses (innovations) that are the true changes and that are of primary interest.

The source of these reanalyses, as briefly stated at the outset, is the discontinuous (and imperfect) transmission of grammars across generations, as was recognized a century or more ago by the Neogrammarians. All of us are exposed to a wide variety of speech from which we must abstract the knowledge necessary to construct a grammar of our native language, whatever it may be.⁷ The process begins in very early childhood, where it follows biologically pre-determined maturational paths whose milestones are reached without overt instruction from mature speakers, and continues during the formation of peer groups in pre-adolescent and adolescent years, and even later.⁸ None of us has direct access to the underlying forms and rules constituting the grammars of other speakers (nor do they themselves!), only to the behavior (speech) that those grammars underlie – hence the discontinuity of grammar transmission.⁹ Language is created afresh, and a little differently, with each new speaker, and with it, its sounds, word meanings, and everything else.¹⁰ If one deduces a different underlying form or rule for producing something that a speaker or the speakers round about are producing, then one has made a reanalysis.

When we as historical linguists strive to understand the nature and the constraints on language change (for example, what constitutes a possible sound change in natural language), what we in fact are striving for is an understanding of what sorts of reanalyses can occur. Here I must interject some terminological clarification. The phrase "language change" refers to at least two quite distinct concepts in the literature, often leading to considerable confusion. Most commonly, probably, it refers to the manifestation of a linguistic innovation throughout a community and its robust appearance in written documents. As an object of study, that is too nebulous a concept (as nebulous as "the English language") because of the impossibility of defining "the language," "throughout a community," "robustly," and similarly vague or subjective criteria that are not, strictly speaking, linguistic. Reanalyses in individual grammars, by contrast, are very discrete entities, and in my opinion if one is to use the term "change" at all, it should refer to individual reanalyses. This is the way I will be using the term.¹¹

Reanalysis is said to arise from ambiguous contexts.¹² To take a familiar example, consider the change undergone by the English word *bead*, originally 'prayer.' Prayers were, as now, often recited while being counted on rosary beads, and a phrase like *to count (or tell) one's beads* had at least two possible interpretations for someone who did not already know what was meant by *bead*: it could conceivably refer to the prayers that were being counted, or the beads (in the modern sense) that were being used for the counting. Some speakers apparently interpreted the meaning of *bead* as 'perforated ball on a string.' While it is not a major point, "ambiguous" is not the best characterization of contexts such as these, since something is ambiguous only if more than one interpretation is actually (not theoretically) available to the interpreter. Reanalysis rests crucially on meanings *not* being available; the word was without meaning to the learner until one was assigned.¹³

Many changes that cannot be classified according to the traditional classificatory scheme are readily understandable as reanalyses. I recently encountered the phrase *he harked* used after a quote and meaning 'he shouted, exclaimed.' It is impossible to subsume the change 'listen attentively' > 'exclaim' under any of the traditional rubrics, at least not without a great deal of special pleading. But anyone knowledgeable of what is probably the most familiar usage of *hark* (imperative, as in the Christmas carol "Hark! the herald angels sing") will immediately have a sense of how this change came about. As an imperative, the word is isolated syntactically, its function is an attention getter, and several of its "standard" uses stem from its association with vocal actions that get one's attention (including, historically, *hark back*, originally said of hounds on the hunt responding to calls of incitement). One can speculate on the exact associations that led, in this speaker's mind, to the sense 'shout, exclaim,' and whether rhyme forms like *bark* played any role; the point is that, as I see it, no traditional category of change can account for this example.¹⁴ It is simply a reanalysis. Another such example is the change of *realize* from 'bring to fruition' to 'understand' discussed by Trask (1996: 42), who comments, "It is not at all

obvious how this change could have occurred, since the new senses actually require a different construction (a *that*-complement clause) from the old sense." This is a pseudo-problem; a verb meaning 'understand' does not have to be followed by a *that*-complement, which means that a verb that is not followed by a *that*-complement (such as *realize* in the sense 'bring to fruition') could still be reanalyzed as 'understand' under the right conditions. There is no connection, metaphoric or metonymic or otherwise, between the concepts 'bring to fruition' and 'understand,' just as there is no connection between the concepts 'listen' and 'shout'; and speaking of "extensions" of meaning in such cases is therefore misleading.¹⁵

In fact, a fundamental flaw of most categorizations of semantic change is that they rest upon the assumption that an old meaning *becomes* the new meaning, that there is some real connection between the two. As these and other examples show, however, this assumption is false; a connection between the new and old meanings is illusory.¹⁶ The set of meanings in a speaker's head is created afresh just like all the other components of the grammar. It may legitimately be asked how it is, then, that one can seem so often to find a connection between an old and a new meaning. In the case of metonymic change, the question makes little sense. Metonymic changes are so infinitely diverse precisely because, as was mentioned earlier, the connections are not linguistic; they are cultural. This has in some sense always been known, but when metonymic extension is defined in terms of an "association" of a word becoming the word's new meaning, we can easily forget that the "association" in question is not linguistic in nature.

If we turn to metaphoric change, the feeling that a metaphorically extended meaning is connected to the original meaning is very strong indeed. If, however, the original literal meaning of a word is opaque to a particular individual, and that individual ascribes to it only the metaphorical meaning, that is a reanalysis; as with other reanalyses, of course, here we have a discontinuity – the original meaning was not *extended* (at least not in any way that it had not been "extended" before). While the reanalysis is just as discontinuous as in metonymic change, unlike the latter there is a clear *semantic* connection between the literal and the metaphoric meanings.

2 Semantic Change and Lexical Change

Some works, such as Jeffers and Lehiste (1979), incorporate the traditional typology of semantic changes, and the attendant discussions, into their treatment of lexical change. In most other works, such as Hock and Joseph (1996), however, lexical change and semantic change are kept apart. Lexical change is generally used to refer to new words entering the lexicon (by borrowing, word creation, or other processes, as in Crowley 1997), although Hock and Joseph subsume under lexical change any change (phonological, morphological,

semantic, as well as borrowing, etc.) that has an effect on the lexicon. The terminology does not interest me so much as the assumptions underlying these different choices in treatment. We have discussed how grammar construction involves a discontinuity between the new grammar and the mature grammars of other speakers; each new grammar must be constructed from scratch. This of course includes the lexicon. Authors who restrict lexical change to processes such as borrowing or synchronic lexical innovation are essentially defining lexical change in terms of “the language” (“when a new word enters *the language*”). As noted previously, this ignores individual grammar construction, and treats “language,” as well as the lexicon, non-scientifically, as entities that are “out there,” shared among (or existing in the air around?) many speakers. Once the individual language learner is brought into the picture, one does not have to be terribly reductionist to see that borrowing is not meaningfully different from building a lexicon during language acquisition. In the case of the latter, words are being entered into the lexicon, their meanings are being deduced (sometimes with differences from other speakers, i.e., with “semantic change”), and the process repeats itself throughout life as one learns new words.

A similar issue that is often confronted in the literature on semantic change is whether a particular semantic innovation constitutes “language change” or not. Most linguists recoil from the idea that the daily metaphorical and metonymic uses of words should be so characterized. Put in these terms, these questions are meaningless and unanswerable, again because “language change” is not a clearly defined or definable concept. But, as with the issue discussed in the preceding paragraph, if we frame the question in terms of reanalyses and with respect to individual speakers, we will find an answer quite readily – although it will vary from speaker to speaker, just as grammars are different from speaker to speaker. Take, for example, the idioms *surf the Web* and *channel-surfing*, recently innovated metaphorical uses of *surf*. Anyone who has learned the phrases and added them to his or her lexicon has changed his or her knowledge of English. But no reanalysis has occurred; *surf* continues to have, as one of its meanings, the old literal meaning that it always had. Only if one acquires *surf* in its new metaphorical meanings without (for whatever reason) acquiring the literal meaning has a reanalysis happened.

2.1 *The role of children in semantic change*

It was mentioned above (n. 10) that the role of children in instigating semantic change is a contentious issue. It was further noted that none of the views and conclusions about the nature of semantic change that are presented in this chapter depends crucially on the resolution of this issue. However, since it is important and much discussed, let me address it briefly before moving on to grammaticalization. The Neogrammarians and, more recently, Halle (1962) argued that children were the primary instigators of language change; this

view has been criticized for several decades by sociolinguists on the grounds that it is unrealistically reductive, does not adequately take into account the variation that is part and parcel of the linguistic data around us, and does not take into account the fact (as elucidated in sociolinguistic studies) that children are constantly modifying their grammars under the influence of a succession of prestige-holding peer groups throughout their pre-adolescent years. Weinreich et al. (1968: 188), a watershed study for sociolinguistic theories of language change,¹⁷ famously decreed that no change was possible without variation and heterogeneity.¹⁸ These criticisms, while certainly well taken in several respects, do not of course invalidate the essential insight of the Neogrammarians that language change is based on the discontinuity of grammar transmission.¹⁹ Throughout life, all of us are exposed to linguistic output; *when* we are exposed to it and *whose* output it is may be significant for sociological and sociolinguistic studies, but are otherwise irrelevant both to my arguments and to an understanding of linguistic innovations.²⁰

I rather suspect that one source of the controversy over whether young (pre-school) children play a role in semantic change is the conflicting uses and understanding of the terms “change” and “language change.” If “language change” is taken to mean “diffusion of innovations through a community,” as it is generally used in the sociolinguistic literature, then the validity of the claim that “children cause language change” is entirely dependent on the prestige of individual young children; and since “[b]abies do not form influential social groups,” in the words of Aitchison (1981, here cited from 1991: 173), one can (under this understanding of “language change”) only say, as she does, that “children have little importance to contribute to language change . . . [c]hanges begin within social groups, when group members unconsciously imitate those around them.” If, however, “language change” is taken to mean “reanalysis” or “innovation” on the part of individuals, then saying that children cause language change is quite true; they are no more immune from reanalyzing other speakers’ outputs than the rest of us.²¹

This concludes my review of general issues surrounding semantic change, both taken alone and considered within the broader picture of language change. Some oversimplification has been unfortunately unavoidable due to space limitations, but I believe the conclusions to be sound. In the remainder of this chapter we will concentrate on grammaticalization, and discuss remaining issues (such as the directionality of semantic change) in that context.²²

3 Grammaticalization

Probably no other topic in semantic change (or syntactic change, since it is also discussed frequently in that context) has received as much attention in the past few decades as grammaticalization (or grammaticization). Although it is treated in detail by specialists elsewhere in this volume, I would like to

offer some comments on it, since my views are not orthodox in all respects. Again, because of space limitations, some oversimplification is unfortunately unavoidable.

Grammaticalization can be defined as the process whereby a full-content lexical word becomes a function word or even an affix.²³ The histories of prepositions, conjunctions, affixes, and all manner of sentential and elocutionary particles are often stories of grammaticalization. English prepositions and conjunctions like *behind*, *across*, and *because* were originally prepositional phrases containing the nouns *hind*, *cross*, *cause*. One can compare Swahili *ndani* 'inside, into' (< *da* 'guts'), Kpelle *-lá* 'inside' (< 'mouth'), and Mixtec *ini* 'inside' (< 'heart').²⁴ Negators in many languages can be descended from full-content words with no negative meaning at all originally, as French *pas* (from Latin *passus* 'a step') or English vulgar slang *shit*, *dick*, *fuck-all* 'nothing'; these were used with negatives originally to strengthen their force, and became reanalyzed as the negative elements all on their own.²⁵

The literature on grammaticalization is large because of a widespread sense that there is something special about it. "The cross-componential change *par excellence*, involving as it does developments in the phonology, morphology, syntax and semantics" (McMahon 1994a: 161) is by no means an unusual characterization of the phenomenon. When it is so characterized, of course it appears to be an entirely different animal from, for example, metonymic change, or a sound change like assimilation. I have yet to find evidence that this characterization is accurate. The source of grammaticalization is the same as the source of phonological, morphological, semantic, and syntactic change – reanalysis of potentially ambiguous strings (see the next paragraph for discussion of an example).²⁶ The fact that the reanalyses leading to grammaticalization have (or can have) repercussions beyond the semantic component of the grammar is irrelevant (sound changes can have similar effects, e.g., apocope that results in reduction or loss of case systems); and I would urge researchers to reconsider whether the repercussions are even what they are claimed to be. Put another way, reanalysis of a word as a grammatical element does not in itself mean that any module of the grammar outside the lexicon has changed, in spite of appearances to the contrary. Old English *willan* and *cunnan* gradually lost their force as full lexical verbs and became grammaticalized as the modals *will* and *can*, but that is not (*contra* the usual analysis) a syntactic change; that is purely a *lexical* change – the rules for stringing words together into phrases and sentences (i.e., the syntax) remained the same at the moment these words were reanalyzed. (This is not meant to deny the existence of reanalyses that simultaneously cause a change in lexical representation as well as syntactic structure, but simply to point out that not all putative examples in the literature are indeed examples.)

Consider as a further example the reanalysis of verbs into prepositions, a rather common change: Thai *maa* 'to(ward)' is historically the verb 'come,' *càak* 'from' is from 'leave,' and Ewe *ná* 'for' is from 'give' (Blake 1994: 163–4). The verbs in question were often used to fill out the meaning of other verbs to

express directionality: a non-directional motion verb like *walk* could be combined serially with a directional verb like *come* to mean ‘walk to,’ or *leave* to mean ‘walk away from.’ A sequence beginning literally *walk come the house* can be structurally reinterpreted as a combination of verb plus preposition (equivalent to *walk to the house*) rather than as verb plus verb. In one sense, there has in fact been no change: the meaning of the phrase is still the same, only the lexical specification of one of the words has changed due to the structural reanalysis. (In these languages there is in fact often a split: the verb is still alive and well, and a second, homonymous word has come into existence with a prepositional function, used in different contexts from the verb.)

Grammaticalization has often been portrayed as a gradual process (as by Traugott and Heine, both this volume),²⁷ but the analysis of, say, Thai *maa* in certain contexts as a preposition and not a verb is, like other (re)analyses, instantaneous. One must not conflate the succession of diachronic events that precede a reanalysis with the reanalysis itself: regardless of how many prior events made the grammaticalization of *maa*, for instance, ultimately possible, during that whole period *maa* was a verb, not a preposition, and the change from verb to preposition was just the next event in the unending series of events that constitute the history of Thai.²⁸ (I do not wish to say that it is unimportant to study these prior events – quite the contrary.)

4 Directionality in Grammaticalization and Semantic Change

Numerous scholars have set up explicit and detailed clines to map out an apparent unidirectionality that characterizes grammaticalization. As this topic is covered in detail in Traugott (this volume) and in the literature cited there, I will not embark on a full discussion, save to outline some hypotheses for further consideration. Traugott, in a number of articles (e.g., 1982, 1985, 1989, and this volume), has argued that there are three overarching tendencies to be found characterizing semantic change: words that start out with a purely “external” meaning acquire one that is more “internal,” that is, tied to perception or evaluation (such as *boor* ‘farmer’ > ‘oaf,’ *feel* ‘touch’ > ‘have an opinion, think’); “external” meanings turn into textual meanings that structure discourse (e.g., *while* ‘period of time’ > ‘period of time (during which something happens)’); and meanings become increasingly subjective (e.g., *apparently* ‘openly’ > ‘to all appearances’). Ideally, these tendencies would reflect overarching principles of semantic change, which, needless to say, would be an enormously valuable advance.

My assessment of this literature is that it is at the least premature to ascribe such weight to these tendencies (and others that have been put forward), and in fact I rather doubt that they represent any overarching principles governing semantic change; rather, they are epiphenomenal. Let us consider as an example

first the Hittite quotative particle *-wa(r)*, which can represent the standard shift from referential or concrete to more abstract meaning: in the usually accepted etymology, it is derived from a form of PIE **uer-* ‘say,’ probably an aorist **uert* ‘said (3rd sg.),’ which in Common Anatolian became grammaticalized as a quotative particle.²⁹ The types of reanalyses responsible for the grammaticalization have been well documented by Traugott and others. The question that arises is, is there anything that could cause a change in the other direction, from quotative particle to (say) verb of speaking? For this to happen by a reanalysis, this unstressed particle, with no inflectional endings, would somehow have to be reinterpreted as an inflected content word. Perhaps this is not impossible, but the conditions allowing such an analysis are surely very rare.³⁰

To take a second example, English *since* had a purely temporal meaning in the first instance (‘after’), and out of this developed a secondary, subjective, causal meaning (‘because’); this is a classic example of the supposed principle that grammaticalization and semantic change in general proceed toward more subjective meanings. Could the reverse happen – could a subjective expression of causality get reanalyzed as an objective expression of temporal succession? In the case of a word like *since*, which can be used as either a causal or a temporal conjunction, this might well be possible by narrowing. In the case of a word like *because*, which has only causal meaning, it is much harder to envision how it could ever come to mean, say, ‘after.’ Causality can imply temporal succession, since an event that causes another event must precede that event in time or be already present. For a conjunction like *because* to become a temporal adverb only, it must be stripped of its causal meaning as the result of a reanalysis whereby the presence of the causal meaning was not perceived. Such a reanalysis would only make sense if *because* were limited to contexts where a temporal interpretation (‘after’) was possible. This could only happen if the word were restricted to use with verbs expressing actions that precede the actions of matrix clause verbs. Such a restriction is not likely, however, since something can happen because something else *is* (contemporaneously) or *will be* the case. I do not know any examples of causal conjunctions with the type of restriction in usage outlined above; and the rarity of such examples presumably accounts for the rarity of the shift from subjective to objective meaning (at least in this case).³¹ What we see from all this is, again, that the probable reason that Traugott’s and others’ directional tendencies seem true is not because such tendencies exist as reifiable entities influencing semantic change, but rather because the contexts in which the opposite direction could be taken are rare to non-existent; and the reason they are rare to non-existent flows from more elementary principles.

Another tendency that has been forwarded (one belonging a bit more in the realm of morphological than semantic change, but germane to our topic as well) is the shift from function word to affix, supposedly strongly preferred over shifts in the other direction. This also follows from more basic principles. The change of function word (say, postposition) to affix is made rather easy by the usual phonological factors involved: function words are unstressed and

frequently cliticize, and a reanalysis of a clitic that is attached to one part of speech as an affix is a relatively trivial change. Typically, the affix would live on as an unstressed entity, subject to further phonological weakening perhaps. For the opposite to happen, the conditions would have to be right for a phonologically dependent clitic or affix to be reanalyzed as a separate word. Such changes can occur, but affixes generally do not behave phonologically as independent words.³² I therefore see the directionality (function word > affix) as epiphenomenal, and not an independent property of semantic change itself.³³

The preceding discussion is of course far from a complete consideration of the careful and thoughtful work that Traugott and others have given these matters over the past few decades, and I hope to address these issues in more detail elsewhere. The tendencies that they have identified are in themselves perfectly valid, and can be put to great use in diachronic analysis of the histories of particular languages. I merely wish to point out that we should be careful how we interpret these tendencies, and the proposed unidirectionality of grammaticalization that they imply.³⁴

Outside of the realm of grammaticalization, a large number of recurrent semantic changes are seen, as those examples given at the outset of this chapter. These reflect certain basic metaphorical extensions that all humans can construct, and so it is not surprising that they are found again and again in the histories of languages. Those that have so far been investigated are not unidirectional, but at least one study is suggestive that unidirectional changes may in fact exist. Jurafsky (1996) has claimed that the manifold uses to which diminutives are put cross-linguistically all stem from the notion of 'child' or 'small' (often, in fact, from an actual word for 'child' that got grammaticalized), and that developments in the other direction (e.g., a pejorative formation becoming an ordinary diminutive) are not found. His observations and analysis still await further refinement and empirical testing, but should they be proved correct, we may have finally discovered not only whether there exist true unidirectional changes, but also whether their unidirectionality is not simply epiphenomenal.

5 Grammaticalization and Frequency

The frequency of a linguistic form has often been viewed as a factor influencing language change; how it influences change – whether it catalyzes it, or keeps it in check – depends on what kind of change is being talked about and which scholars are talking about it.³⁵ Paul (1880: 86) opined that semantic change affects uncommon words more often than common ones, the reason being that a misconception about the meaning of a word has a greater chance of getting corrected from frequent exposure to the word in its correct usage. This intuitively makes some sense, but is not borne out by the facts. Grammaticalizations in particular provide many examples of quite common words that

have undergone semantic reanalysis. Since, therefore, both frequent and infrequent words undergo semantic change, frequency does not appear to be a relevant factor.³⁶

In contrast to Paul's statement, frequency is considered a precondition for grammaticalization by several scholars (see Bybee, this volume, for much more detailed discussion of the whole issue). This is a difficult claim to evaluate because of the different uses to which the term "grammaticalization" is put; it sometimes refers to the whole "process" that I discussed above, and sometimes just to the reanalysis that causes a word to become a grammatical element. To take the latter usage first, it may in fact be true that all examples involve frequently occurring words, but this would certainly be epiphenomenal: as we have just discussed, frequency itself does not cause reanalysis, and grammaticalization (in this narrower sense) is reanalysis. In the broader sense, where grammaticalization is conceived of as a process, there are clear counterexamples for subparts of that process. Consider the phrases *pitch-black* and *pitch-dark*. Joseph (1992), in a different context, calls attention to the interesting fact that some speakers have reanalyzed these phrases as meaning 'very black/dark' rather than literally as 'black/dark as pitch'; *pitch-* was thus analyzed by them as a color intensifier, and they are able to generate phrases like *pitch-red* 'very red.' For them, *pitch-* has been at the very least delexicalized (and might at some future date become grammaticalized as a general intensive); and this quite in spite of the fact that neither *pitch* 'tar' nor *pitch-black* is terribly common.³⁷

All that is really necessary for this reanalysis to happen is for the historical connection between the first compound member *pitch-* and the noun *pitch* to be opaque. While the factors causing opacity are far from clear, frequency is not one of them. Opacity, being the failure to analyze a form according to its historical morphosemantic composition, is itself a kind of reanalysis – a negative kind, a lack of an analysis that had been made by other speakers. Perhaps order of acquisition is at the root of this particular example: if *pitch-black* were encountered before the noun *pitch* (not an unreasonable supposition, and in line with the data in n. 28), a child or other learner would be unable to interpret it with reference to a noun he or she had not even learned yet.³⁸

We have seen, then, that both frequent and infrequent forms can be reanalyzed; both frequent and infrequent forms can be grammaticalized. If all these things happen, then frequency loses much or all of its force as an explanatory tool or condition of semantic change and grammaticalization. The reasons are not surprising, and underscore the sources of semantic change again. Frequent exposure to an irregular morpheme, for example (such as English *is*, *are*), can insure the acquisition of that morpheme because it is a discrete physical entity whose form is not in doubt to a child. By contrast, no matter how frequent a word is, its semantic representation always has to be inferred. Classical Chinese *shì* was a demonstrative pronoun that was subsequently reanalyzed as a copula; exposure to *shì* must have been very frequent to language learners, but so must have been the chances for reanalysis.

6 Conclusion

The limitless variety of semantic change has often been a source of consternation. Hock and Joseph's textbook on historical linguistics is one of the more recent places this consternation can be found expressed (1996: 252):

in the majority of cases semantic change is as fuzzy, self-contradictory, and difficult to predict as lexical semantics itself. This is the reason that after initial claims that they will at long last successfully deal with semantics, just about all linguistic theories quickly return to business as usual and concentrate on the structural aspects of language, which are more systematic and therefore easier to deal with.

Certainly the *results* of semantic change are often wildly idiosyncratic. Given the limitless variety of human cultures and creativity, this is fully expected. The fact is, there *are* no constraints on semantic change if one just views the relationship between the referents involved. One simply cannot rule out a given hypothetical semantic shift, in the way that one can rule out a given hypothetical sound change (e.g., a one-step sound change like $i > k^w$); it is only when extralinguistic cultural facts are taken into consideration (e.g., the fact that beads were associated with praying) that certain patterns emerge (the traditional categories of metaphor, metonymy, etc.).

In this chapter, I have taken issue with a number of relatively standard practices, assumptions, and terms in the study of semantic change, while trying to present them in a balanced manner suitable for an introduction to this fascinating area of historical linguistics. I have argued that much previous research has tended to obscure the nature and our understanding of semantic change as a non-gradual event. I have also stressed the importance of clearly defining our objects of study, and limiting our questions and investigations to concepts that are discrete, such as individual reanalyses and individual grammars. When this is done, many questions that had hitherto been *cruxes* turn out to be red herrings, such as when a semantic change constitutes language change. In this vein, I have tried to emphasize the importance of distinguishing between reanalyses and the spread or diffusion of change, which is a separate sociolinguistic issue.

Since in my view the results of change are not as important for an understanding of its mechanisms as the reanalyses and the contexts which enable them to happen, I argue for a different view of grammaticalization as a type of change really no different from any other semantic change. As with other types of change, I argue that the purported unidirectionality and "tendencies" of grammaticalization are not primes of semantic change, but epiphenomena derivable from more basic principles. The efforts of Traugott and others to isolate the discourse conditions that can lead to grammaticalization can be profitably extended to isolating the conditions that can lead to reanalysis more generally, and while I have my doubts that the proposed tendencies

of directionality in semantic change mean what they are sometimes claimed to mean, the research program out of which they have sprung is a very promising one indeed.

ACKNOWLEDGMENT

For invaluable assistance with the bibliography and for numerous helpful suggestions and criticisms on earlier drafts I am indebted to both Brian Joseph and Richard Janda. I should note, though, that our views do not coincide on all points, and responsibility for any errors, of course, rests solely with me.

NOTES

- 1 See, for example, Arlotto (1972); Jeffers and Lehiste (1979); Hock (1991); McMahon (1994a); Crowley (1997); Hock and Joseph (1996); Trask (1996); as well as more specialized works like Goyvaerts (1981).
- 2 This, the standard take on bleaching, has some detractors who would argue that bleaching actually involves the addition of content; see Rubba (1994: 95).
- 3 I leave aside the question of whether broadening and narrowing might be leftovers of the semantic over- and underextension found in certain stages of child language acquisition; to my mind it seems possible that some instances of them could be, though in the absence of unambiguous examples I would not insist on it. (Barrett 1995: 378 implies that all overextensions go by the board.)
- 4 Cf. Hoenigswald (1960: 46), who remarks that a closed inventory is "an illusion."
- 5 Broadening, for example, is traditionally kept distinct from metaphor and metonymy, but is reducible to the former: if *dog* used to refer to a particular breed of dog, its subsequent use to refer to other breeds must have rested on a similarity perceived between that breed and other breeds. Melioration and pejoration are subsumable under metonymic change. Narrowing is no different from loss of meaning through reanalysis: if early speakers of English were using the word *deer* 'wild animal' preferentially of cervids ('the wild animal,' for whatever cultural or environmental reason), then succeeding generations could well understand *deer* to refer just to cervids, and not to other animals. We might then say that for the early English, the deer was the wild animal *par excellence*. See also n. 13 below for further discussion of this word.
- 6 Noted explicitly, for example, in Andersen (1974) and Hughes (1992); but such criticisms clearly have not percolated into the general scholarly consciousness. It may be mentioned in passing, by way of comparison, that the traditional categories of sound change also refer just to results of change: assimilation,

dissimilation, metathesis, lenition, fortition, syncope, epenthesis, and the whole lot of seemingly discrete types are merely different surface manifestations – results – of reanalysis of ambiguous acoustic cues. See on this especially Ohala (1989, 1993a); Blevins and Garrett (1998); and Hale (this volume).

- 7 I say “a grammar” and not “the grammar” so as not to imply the existence of some ideal grammar that exists independently of individual speakers. See also n. 9 below.
- 8 For an overview, see, for example, Aitchison (1989) and Pinker (1994).
- 9 To be picky, it is a misnomer to speak of grammar *transmission*; what occurs is successive instantiations of knowledge states. One also often reads about the acquisition of a “target grammar,” but I doubt this phrase is accurate, either. Given the diversity of outputs that people are exposed to, it is difficult (at best) to conceive of some ideal grammar that exists in the air, as it were, toward which any speaker could strive. I therefore disagree with views such as those in Ohala (1993a). At the very least one would have to conceive of a multiple series of “targets” (see Weinreich et al. 1968: 145 and discussion below in the main text).
- 10 I should stress that the discontinuity described above is what is crucial, not the point in one’s life at which the innovations actually occur (during or after early childhood, for example), which is a contentious question. See below in main text for more discussion of this issue.
- 11 The inadequacy of the term “change” has been pointed out by others, for example, Coseriu (1983: 57): “linguistic change is not ‘change’ but *the construction, the making of language*” (emphasis in original). See also Ehala (1996: 5); Andersen (1973: 767, and especially 1989: 12), who prefers to speak of “innovation” rather than “change,” a practice I have in part adopted. I return to these matters further below.
- 12 An approach that underscores the importance of ambiguous contexts and combines this with the intergenerational break between grammars goes at least as far back as Jespersen’s work in the early 1920s (see, e.g., Jespersen 1921: 175–6).
- 13 In the case of *bead*, one could argue that the introduction of *prayer*, borrowed from French, was responsible for the change of meaning by “crowding out” the meaning ‘prayer’ from *bead* itself and leaving the latter open to reinterpretation. Such a position would be taken, for example, in semantic field theory (see below, n. 22). There is, however, no clear evidence from the words’ attestations that this is what happened: *bead* and *prayer* happily coexisted for several centuries. They are even found several times in the 1300s and 1400s together in the phrase *beads and prayers*, proving that individual speakers could tolerate this coexistence without trouble.

The historical linguistic literature is full of purported examples of words “crowding out” other words. The textual evidence is always the same: word A, the old word, is attested more and more sparsely during a period in which the attestations of word B, the young upstart, are increasing. Thus *deer*, for example, originally meant ‘wild animal’ and developed the meaning ‘cervid’ probably before the twelfth

century. By the close of the fifteenth century, its original meaning had died out except in the fixed phrase *small deer*. This period coincides with the introduction of a new word for the concept 'animal,' namely *beast* (from French, in the early thirteenth century) whose attestations become more widespread over time. But correlation is not causation, and there are countless instances where the introduction of a new word did not correlate with the disappearance of an older, synonymous word (consider the pairs *beak/bill*, *valley/dale*, *aid/help*, where the first member of each pair is a French borrowing). Such statements in fact leave the speaker and the sociolinguistic situation out of the picture. For whatever sociolinguistic reason, the number of people using *beast* started to increase (first starting in and around the French court and nobility); this in turn increased the likelihood that other speakers and learners of English would hear this word more than *deer* as the word for 'animal,' and the sociolinguistic prestige of French led to more adult speakers adopting the word, whose children then would have heard them say *beast* and not *deer*, and so forth. In other words, I do not think there is clear evidence that the replacement of *deer* 'animal' by *beast* (and, later, by *animal*) has anything to do with the crowding of a semantic field; it happened for the sociolinguistic reasons that *beast* was the new prestige form, and because the linguistic data new generations were exposed to contained more tokens of *beast* than of *deer* 'animal.'

14 This is assuming that *harked* is not a delocutive to the interjection *hark*, along the lines of Latin *negāre*, German *be-ja(h)-en*, etc., in which

case we are not dealing with semantic change at all, but with the productive formation of a new lexical item.

15 A more complicated sort of reanalysis, more overtly involving a lack of "connection" between the old and new meanings, is when a word's meaning is assigned on the basis of a similar-sounding word; a recent example is *energated*, which has been enjoying usage in the opposite sense from its "correct" meaning, namely, 'energized' instead of 'drained.' There is a certain similarity to folk etymology here, except that rather than the phonological shape changing under the influence of another lexeme (and the meaning remaining intact), the phonological shape remains but the meaning is analyzed on the basis of another lexeme. Such cases go to show that context is not the only information used to assign meaning to unfamiliar words. Ringe (1989: 149n.26), following an oral suggestion of Richard Janda (who noted the influence of *indifferent* on the meaning of *diffident* in contemporary non-standard English), says that such changes only happen when the two words are in the same semantic sphere. However, this claim is not true; consider, for example, the infiltration of forms of the Old Irish verb *benaid* 'strikes' into the paradigm of the substantive verb ('exists') due purely to the phonological similarity of forms of these two verbs in the subjunctive and preterite (see Thurneysen 1980: 480).

16 Essentially the same thing was realized already by Paul (1880: 77): "In most of the cases adduced, it is completely impossible without historical study to recognize the

- original connection between the individual meanings, and these are not otherwise related to each other than if the phonetic identity were just coincidental." Stern (1931: 180–1, 356) saw this as well, but drew different conclusions from it.
- 17 See also Bickerton (1973) and Kay (1975), to mention two of the more well-known studies to follow.
- 18 This claim must be understood in the context of sociolinguists' usage of the term 'change,' which refers not to linguistic innovation (my usage) but to diffusion of innovations through a speech-community. I address the use of this term further below in the main text. Linguistic *innovation* (change in the narrow sense) is possible under any environment because of the discontinuity of transmission; a child that grows up hearing the speech of only one person is just as likely to make reanalyses as one surrounded by variation.
- 19 The Neogrammarians, it should be noted, also did not limit language innovation to the agency of children; see Paul (1880: 86). Two well-known examples of adult reanalyses are *derring-do* (a misconstrual of what was originally just a verbal phrase meaning 'to dare to do'; see the OED, *s.v.*) and *premises* (originally 'the [*sc.* properties, possessions] listed above' in legal deeds; discussed in Stern 1931: 358).
- 20 Note that in the case of children, the crucial role of discontinuity holds regardless of what theory one adopts to explain the acquisition of semantics, about which there is much controversy (Barrett 1995 has a good recent overview). In their present state of development, I do not know how much these theories have to offer the historical linguist. For example, prototype theory, one of the more popular ones in recent years (see, e.g., Kay and Anglin 1982), claims that meanings of words are first acquired in the form of a specific referent (the "prototype") rather than as bundles of semantic features. Thus, the meaning of *dog* for one child might be its household's pet Fido in the first instance. Different children would be exposed to different prototypical dogs, which would have an effect on what sorts of referents the words could then be extended to; and conceivably the original prototype could have some sort of lasting effect on the semantics stored in the speaker's head for a given word. This makes a lot of intuitive sense, but whether this is in fact the (or a) mechanism of semantic acquisition, ultimately it adds nothing to our initial observation that discontinuity in language transmission leads to the instantiation of different grammars across generations.
- 21 Even under the first definition, it is only from the viewpoint of the children who "unconsciously imitate those around them" that children do not initiate language change; what about the other children in their social groups from whom they are picking up innovations? Surely they are not all copied from adults – some of them must be the children's own reanalyses made during grammar acquisition. If any of those reanalyses are diffused to other members of their social group, as some of them must be, then children do instigate at least *some* language change, under either definition of the term; and that includes semantic change.
- 22 I shall here mention briefly two other approaches to semantic change that I cannot discuss in detail. One

- is the functionalist explanation of semantic change (e.g., Ullmann 1957, 1962; Geeraerts 1983, 1986), which claims essentially that semantic change has a function, such as to increase communicative efficiency. While it is certainly true that language has a communicative function, that does not automatically mean that language change has one. There is not a whit of evidence that, for instance, the languages of 3000 years ago with modern-day descendants were any less "efficient" (whatever exactly that means, given the well-known redundancy inherent in language) than their descendants (surely enough time for all the supposed improvements to have added up and become noticeable as such). Another approach which may be mentioned here is the use of semantic field theory to account for semantic change (see, e.g., Lehrer 1985 with references, and n. 13 above for an example of where this theory might be claimed to apply). This theory argues that semantically related words share historical developments and that relationships among words bear crucially on their synchronic meanings. This appears to work fairly well in some cases, but Lehrer herself (*ibid.*: 293) admits that it does not in others. I rather suspect that when semantically related words share historical developments, it can be deduced from more basic principles.
- 23 See Heine (this volume) for a good overview of the history of grammaticalization studies.
- 24 For further examples see Blake (1994: 168).
- 25 In such cases, where the original negator no longer needs to be expressed, it is said to have undergone *ellipsis*. Ellipsis is sometimes considered a separate type of semantic change, but it too stems from a reanalysis: in *ne . . . pas*, where it is ambiguous which word is expressing the negative alone, some speakers analyzed *pas* as the salient negator.
- 26 This view is probably not standard; I argue for it more fully in Fortson (2002).
- 27 "[I]t is a salient characteristic in most studies of grammaticalization that they are phrased in terms implying that morphemes exist apart from mortal speakers and so may undergo continuous evolution governed by processes lasting centuries" (Janda 2001: 283).
- 28 I would even hesitate to use the word "process" to describe the events leading up to a reanalysis such as this. No change in language makes another change inevitable, to my knowledge; it may make it more likely, but that is all. "Process" reifies an arbitrarily chosen sequence of historically contingent events. Of course the study of these events, and how they contribute to making certain reanalyses possible, is very important; but since these changes, taken together as a group, occur over many generations, and since (again) each generation has to construct a grammar from scratch, the appearance of an overarching direction taken by a sequence of events is quite illusory.
- 29 See Fortson (1998: 21n.1) for the phonological details. A different etymology is argued for in Joseph (1981).
- 30 The other possible route would be to form a delocutive verb, but that is a different matter since that is just the synchronic creation of a new lexical item using available productive morphology. We would not want to claim, for example, that

- the Latin delocutive verb *negāre* is a reanalysis of the negative *nec* as a verb.
- 31 Such a reanalysis is even harder to imagine given the use of causals like *because* as an answer to questions using *why*. Notice that *since* is not so used.
- 32 Orthographically, of course, they sometimes do (e.g., Avestan spellings with word-dividing interpuncts between base and ending, as in the dative pl. *γzaraiiaṭ.biiō* '(over)flowing' Yasht 15.2), but that is a separate issue.
- 33 Compare also Janda (2001, kindly forwarded to me by the author after these lines were written), which is a significantly lengthier study than mine and makes several points against the unidirectionality hypothesis that – happily – coincide with my own. In particular, this study makes use of examples of degrammaticalization (essentially the same as demorphologization, the term used in Joseph and Janda 1988), whereby a grammaticalized element becomes a full-fledged lexeme. (I think the examples are even rarer than at first appears; several putative cases of degrammaticalization are in fact not reanalyses, but nominalization of a bound morpheme, as in English *pro* and *con*; these must be carefully separated, which has not been done consistently in the literature. Cf. also nn. 14 and 30 above.)
- 34 Tendencies and directionalities of change have been adduced in other contexts besides grammaticalization, but rarely. One interesting example is Williams (1976), who notes particular directional tendencies in English and Japanese in adjectives of sensory perception. He speculates (ibid.: 472) on possible cognitive and evolutionary reasons for this. As he notes, though, some exceptions to his scheme can be found from the history of English. Traugott and Dasher (2002), an important new work on directionality in semantic change, appeared after this chapter went to press, and is reviewed by me in *Diachronica* (forthcoming issue).
- 35 For example, it is often claimed that words are more likely to undergo sound change if they are frequent (a view I disagree with), while morphological change is less likely to affect words that are very frequent, since their frequency makes it hard for the language learner to “miss” their morphological properties.
- 36 To be fair, of course, no one has claimed that frequent words do *not* undergo semantic change, just that it is less common. But this is also a vacuous assertion: even if it is nominally true, it surely just restates the distributional fact that there are fewer frequent words than infrequent ones.
- 37 In the 1,014,232-word corpus analyzed by Kučera and Francis (1967), the token *pitch* (in all senses) occurs but 22 times, and *pitch-black* and *pitch-dark* do not occur. (The number of distinct tokens in the corpus was 50,406.)
- 38 This opacity might or might not get reversed later; I have known people for whom the brandname *Frigidaire* was opaque for the first four to five decades of life, even though the phrase *frigid air* was quite familiar to them. A *Frigidaire* at home while one is learning English is all that is needed for that word to be acquired quite early on, and well before the adjective *frigid*.

Part VII
Explaining Linguistic Change

This page intentionally left blank

22 Phonetics and Historical Phonology

JOHN J. OHALA

Two of the most successful enterprises in linguistics over the past couple of centuries have been (i) in historical linguistics, reconstruction of the prehistory of languages via the comparative method, and (ii) in phonetics, the development of methods and theories for understanding the workings of speech, that is, how it is produced, its acoustic structure, and how it is perceived. My purpose in this chapter is to demonstrate that the comparative method can be refined and elaborated still more if it is integrated with modern scientific phonetics. By incorporating phonetics it is possible to implement a research program that genuinely constitutes “experimental historical phonology” (Ohala 1974).

1 Background

1.1 *Taxonomic versus scientific phonetics*

In speaking of the integration of phonetics into historical phonology it must be understood that “phonetics” refers to what I call “scientific phonetics,”¹ not “taxonomic phonetics.” The latter is the traditional, almost exclusively articulatory phonetics which provides linguistics with the terminology and conceptual framework for describing speech sounds and their natural classes. This descriptive system reached a high level of refinement in the late nineteenth century through the efforts of phoneticians such as Alexander Melville Bell, Otto Jespersen, Paul Passy, Henry Sweet, and Wilhelm Viëtor, and its basic structure has not changed very much since. Scientific phonetics, on the other hand, has a very long tradition, dating at least from the time of Galen, the second-century AD anatomist, with important contributions to the present time from other anatomists, as well as physiologists, physicists, voice teachers, engineers, linguists, and others. It constantly accumulates new data, methods, and theories on how speech works. Moreover, it tests these theories and continually refines

the evidence adduced in support of them. When the evidence fails to support proposed theories, it abandons them, as is true of any mature discipline. It is scientific phonetics, not taxonomic phonetics, that needs to be better joined with historical phonology.

There have, in fact, been many prior attempts to bring about this union. Prior to instrumental studies of speech there were some conceptions of the workings of speech which were based on impressionistic auditory or kinesthetic sensations and on direct visual inspection. Even at this stage of development in the nineteenth century there were some applications of phonetics to historical phonology (Bindseil 1838; Rapp 1836; von Raumer 1863; Weymouth 1856). Some of the early attempts to synthesize speech (von Kempelen 1791; Willis 1830) inspired a few works attempting to explain sound change by reference to physical properties of speech sounds, as they were understood at the time (Jacobi 1843; Key 1855).

Instrumental study of speech on live, intact, speakers blossomed in the 1860s and 1870s.² It is noteworthy that one of the motivations for such research was at its onset the attempt to understand the mechanisms of sound change. In 1876 Rosapelly declared optimistically (I translate) that:

From the point of view of linguists, these (physiological) studies seem to be of great importance, since their science, whose precision grows from day to day, tends to take experimental study as its point of departure. The comparative study of different languages and the study of the successive transformations undergone by each of them in the course of its development have, in fact, permitted the secure formulation of certain laws that one can call physiological and which have presided over the evolution of language.

Within a couple of decades this program produced, among other works, Rousselot's 1891 dissertation, which was an attempt to present the physiological basis of some of the sound changes that transformed late Latin into the regional dialect spoken in his home town.

There is still much of value to be gleaned from such early instrumental phonetic studies. One example is E. A. Meyer's (1896–7) early discovery of the perturbations of F₀ on vowels following voiced and voiceless consonants – one of the topics that still preoccupies phoneticians both for its value to an understanding of speech production (Löfqvist et al. 1989) and for its relevance to the phonological development of distinctive tone from the influence of consonants (Hombert et al. 1979).

In instrumental phonetics, the discovery of the magnitude and range of lawful variation in speech must rank as one of the major findings of linguistic science, although its full significance for an understanding of sound change seems not yet to be fully appreciated. Having said this, it must be admitted that much of this early work in laboratory phonetics had obvious limitations: due to technological constraints it focused almost exclusively on the articulatory aspect of speech and neglected the acoustic and perceptual aspects. As many modern studies have shown and as will be emphasized in this chapter, a

proper understanding of sound change requires reference to these other domains. Perhaps the one aspect of early phonetically informed studies of sound change from which we may still draw inspiration is the expressed belief that sound change and phonological universals may profitably be studied in the laboratory.

1.2 *Constraints of the discussion*

The following discussion of the mechanisms of sound change will be constrained in two ways. First, I will for the most part be concerned only with those sound changes that are independently manifested in similar form in different languages. The practical effect of this is to filter out changes due to language-specific or culture-specific factors, for example, the influence of writing, regularization of morphological paradigms, borrowing, etc. What remains is the vast majority of sound changes that have occupied phonologists' attention over the past two centuries and which one can assume are caused by the only factors that are common to all languages at all periods of time: the physical phonetic properties of the speech production and perception systems. Second, I will focus primarily on the initiation of sound change, that is, the factors that lead to variant pronunciation norms in the first place, not the subsequent spread or transmission of a novel norm through the speech community or through the lexicon. The factors influencing the spread of a sound change are social and psychological and may very well involve language and culture-specific factors. (However, see Ohala 1995c for speculations on phonetic factors influencing some aspects of the spread of a sound change.)

2 The Phonetic Basis of Sound Change

2.1 *Sound change and synchronic phonetic variation*

Detailed phonetic studies present us with two fundamental facts that force us to try to understand sound change by looking carefully at the phonetics of speech production and speech perception. The first of these is that there is a huge amount of variation in the way the "same" phonological unit is pronounced, whether this unit is the phone, syllable, or word. The relatively short list of allophones given in conventional phonemic descriptions of languages is just the "tip of the iceberg."³ Fine-grained instrumental analyses of speech, especially recent acoustic studies, reveal that the variation is essentially infinite, though generally showing lawful dependency with respect to the phonetic environment, speech-style, or characteristics of the individual speaker (Lindblom 1963; Moon and Lindblom 1994; Sproat and Fujimura 1993; Sussman et al. 1991). Most of this variation is difficult to notice perceptually except through the use

of controlled listening tests (e.g., Ohala and Feder 1994). Even after a great deal of ingenious quantitative analysis (Bladon et al. 1984; Miller 1989; Peterson 1951; Syrdal and Gopal 1986) there does not yet exist a universally applicable way to normalize this variation in vowels, that is, to extract the linguistically relevant “sames” posited for the speech signal. Until such normalizations are understood, the validity of most posited phonological units remains in doubt. It is this situation that I was referring to when I stated above that the wealth of phonetic variation discovered by instrumental phonetics confronts linguistics with a problem that it has yet to deal with.

The second fundamental fact that motivates us to look at phonetics for an understanding of sound change is that a great deal of phonetic variation parallels sound change, that is, synchronic variation, including that which we find in present-day speech, resembles diachronic variation. The synchronic variation can be found both in speech production and in speech perception.

2.2 Variation in speech production

For example, the fundamental frequency of vowels is perturbed by the voicing of preceding consonants: higher initial F₀ being found after voiceless consonants and lower initial F₀ after voiced ones (Meyer 1896–7). This parallels the conditioning of new tones in a number of languages (Edkins 1864; Maspero 1912; Hombert et al. 1979). Svantesson (1983) provides examples of this from two related dialects of Kammu, one of which has preserved the voicing of initial stops and the other of which has lost the voicing but has acquired a tonal distinction; see (1):

(1)	<i>Southern Kammu</i>	<i>Northern Kammu</i>	<i>Translation</i>
	klaaŋ	kláaŋ	‘eagle’
	glaaŋ	klàaŋ	‘stone’

A second example is the fact that the intensity and the duration of the noise element in the release burst of [t] is greater preceding the high close vowel [i] or the glide [j] than it is before other vowels (Olive et al. 1993: 286; Ohala 1989). This finds a parallel in the phonological histories of numerous languages, for example, Tai (Li 1977) and Bantu (Guthrie 1967–71) as well as English, where stops develop affricated releases before high, close vowels, as exemplified in (2):

- (2) English: *actual* [ækʃuəl] < /ækt + juəl/
 dialectal variants: *truck* [tɹʌk] ~ [ʃɹʌk]
 French: Late Latin *dīurnum* ‘day’ > djornu > dʒorn > zuɾ (Pope 1934: 131, transcription modified)
 Bantu: Proto-Bantu *-dib- > Mvumbo dʒiwo ‘shut’
 Cf. *-di > -di ‘eat’ (Guthrie 1967–1970; transcription modified)

Table 22.1 Data from Ikalanga showing that distinctive aspiration has developed on stops that appeared before the Proto-Bantu super-close vowels but not before the next lower vowels

Image Not Available

A third example is the finding that voice onset following a voiceless stop release is longer before high, close vowels than before low, open vowels (Halle and Smith 1952; Klatt 1975; Ohala 1981b). A diachronic parallel to this is the development of distinctive aspiration on voiceless stops in Ikalanga (Mathangwane 1996). In Ikalanga (and many other Bantu languages) distinctive aspiration on certain stops arose out of the height neutralization of the quality of the two highest front and back vowels, as shown in table 22.1.

2.3 *Variation in speech perception*

Listeners occasionally make errors in perceiving speech. This is especially true when there is minimal higher-level redundancy from pragmatics, semantics, syntax, and the lexicon. Such a situation is easily duplicated in laboratory-based confusion studies where isolated nonsense syllables are presented to listeners for identification. The results from one condition of one published study by Winitz et al. (1972) is given in table 22.2.

The confusions shown in table 22.2 parallel some common, well-documented sound changes, as given in table 22.3. The parallels include the pairs of sounds involved, the phonetic environment (especially, whether the stops are found in palatal or labial environments – where the palatalization or labialization is provided by secondary articulations or by adjacent vowels or glides), and, in some cases, even the asymmetry in the direction of the change ($/p^j/ > /t/$ is attested but not $*/t/ > /p^j/$).⁴ Many other examples could be given (see Ohala 1981a, 1993a, 1995b).

To recapitulate:

- i much variation can be found in speech production and speech perception;
- ii much of this variation parallels sound change.

Table 22.2 Probabilities of identification of initial consonants as /p/, /t/, /k/ in the columns of the stimuli in the rows

Spoken ↓	Heard →	/p/	/t/	/k/
	/pi/	.46	.38	.17
	/pa/	.83	.07	.11
	/pu/	.68	.10	.23
	/ti/	.03	.88	.09
	/ta/	.15	.63	.22
	/tu/	.10	.80	.11
	/ki/	.15	.47	.38
	/ka/	.11	.20	.70
	/ku/	.24	.18	.58

Notes: Values on the diagonal (with borders) represent correct judgments; those off the diagonal are misperceptions. The average rate of misperception is .173. Confusions that occurred at much higher rate than this are given in italics.

Source: Winitz et al. (1972)

Table 22.3 Examples of sound changes involving large changes in place of articulation

Sound change	Language	Example	Origin, root
k > t, tʃ, ʃ, s/ ___ i, j	English	<i>chicken</i> [ˈtʃɪkən]	<i>cocc</i> + diminutive
k > t, tʃ, ʃ, s/ ___ i, j	English	<i>church</i> [tʃɜːtʃ]	<i>kirke</i>
k > t, tʃ, ʃ, s/ ___ i, j	French	<i>racine</i> [ʁasin]	Gallo-Roman
		‘root’ < <i>ratsinǝ</i>	<i>radi’ki:na</i>
k > p / ___ u, w	Classical Greek	<i>hippos</i> ‘horse’	PIE * <i>ekwos</i>
k > p / ___ u, w	West Teke	<i>pfuma</i> ‘chief’	PB *- <i>kumu</i>
p > t / ___ i, j	E. Bohemian Czech	<i>tět</i> ‘five’	<i>p’ět</i>
p > t / ___ i, j	Genoese Italian	<i>tʃena</i> ‘full’	<i>pjeno</i>
p > t / ___ i, j	Zulu	-tʃ ^h a ‘new’	PB * <i>pia</i>

But these two facts immediately raise the question: could this synchronic variation actually be sound change observed “on the hoof”? Logically this would be difficult to accept, because if this were the case then we would find sound change progressing at a rate very much faster than we do – in fact, several orders of magnitude faster than present evidence suggests. All of the sound changes that transformed Proto-Indo-European over five or six millennia into the present-day Indo-European languages would be accomplished in a day or less. Somehow pronunciation remains relatively stable over time in spite of the great

variation seen in everyday speech. But if present-day variation is not sound change, then how do we account for the uncanny similarities between them?

2.4 *Variation in speech production = sound change?*

The beginnings of a resolution of this paradox comes from experimental phonetics, specifically from studies of speech perception. Several studies have shown that listeners' judgments about what it is that they hear in the speech signal are influenced by the context in which the sounds occur. Pickett and Decker (1960) showed that listeners' differentiation between *topic* and *top pick* is influenced by the rate at which the sentence containing these utterances is spoken. Ladefoged and Broadbent (1957) showed that listeners would identify the same vowel stimulus as /ɪ/ or /ɛ/ depending on the F1 values of vowels in a precursor sentence.

Two studies are particularly relevant to an understanding of sound change. Mann and Repp (1981) showed that listeners divide an /ʃ/ to /s/ continuum differently depending on the quality of the following vowel. Some stimuli that would be regarded as an /ʃ/ before the vowel /a/ are identified as /s/ before the vowel /u/. Presumably listeners are aware that a rounded vowel such as /u/ lowers the frequency of /s/ toward that of /ʃ/ and thus perceptually compensate or normalize for that effect. Similarly, Beddor et al. (1986) looked at how listeners divided an /ɛ/ to /æ/ continuum under three conditions: when the vowels were oral in an oral consonant context (ɛd-æd), when the vowels were nasalized in an oral consonant context (ɛ̃d-æ̃d), and when the vowels were nasalized and followed by a nasal consonant (ɛ̃n-æ̃n). They found that in comparison to the /ɛd/ condition, listeners heard more /æ/ vowels in the continuum in the /ɛ̃d/ condition. This is to be expected given the kind of distortion of vowel quality created by nasalization. But most important, in the /ɛ̃n/ condition, the responses were in most cases virtually identical to those in the /ɛd/ condition. The implication is that when listeners have a contextual nasal consonant to "blame" for the distortions on the vowel, they are able to factor out those distortions and normalize back to the speaker's presumed intended vowel quality.

The ability of listeners to normalize variable speech presupposes long experience with variation in speech: speakers produce variation in their speech but listeners learn how to factor it out or, more precisely, they learn how to parse the nasalization to the nasal and dissociate it from the effects it has on the vowel.

The fact that listeners use context to adjust their perceptual criteria in recognizing the objects of speech should not be surprising. This is a manifestation of the phenomenon known in psychology as "perceptual constancy" and is well studied in other sensory domains. In vision we somehow manage to achieve constancy in the perception of the size, shape, and color of objects seen even when there are remarkable variations in those parameters as our eyes register them (Rock 1983).

Thus to return to the question posed above, we can give the following answer regarding the variation seen in speech production: variation in the production domain does not by itself constitute sound change *since there is no change in the pronunciation norm*; the listener is able (somehow) to reconstruct the speaker's intended pronunciation. I think we can maintain this position even in cases where speakers may deliberately (if unconsciously) take articulatory "short cuts" but assume that listeners can nevertheless figure out what they were aiming at. Similarly, in writing anyone who uses or even invents an abbr. for a wd assumes the reader can figure out what was intended; no change in the spelling norm for the abbreviated word is intended or taken.

Of course, occasionally the listener may fail to normalize or correct the contextually determined variations in the speech signal. In such cases a new norm *does* develop and a sound change occurs. I have referred to such cases as "mini-sound changes" – "mini" because at initiation such sound changes are limited to a given listener and a given word or sound. This is why variations in production resemble sound change; they can create ambiguity in the speech signal which the listener is unable to resolve. The listener, however, is the final (unwitting) gatekeeper regarding which production variants become sound changes.⁵

2.5 *Variation in speech perception = sound change?*

In the case of variation in speech perception, we have to answer the question in the affirmative. Misperceptions *are* potential sound changes because they may result in a changed pronunciation norm on the part of listeners if their misperceptions are guides to their own pronunciation.

2.6 *"Mini" sound changes*

This conception of sound change, however, still does not fully answer the question: even if not all production variation becomes sound change, the rate at which such mini-sound changes would occur would still be very high. And perceptual errors probably also occur at a rather high rate. We are still left to wonder at the discrepancy between the expected high rate of sound change and its actually observed slow rate. The final resolution to the paradox is to recognize that most listeners' errors eventually get corrected. Listeners have more than one opportunity or more than one source from which to learn the pronunciation of words; the probability of making the same error many times is no doubt quite low. Finally, even in cases where a listener's error goes uncorrected, it may perish with the individual who made it, that is, other speakers may not copy it and thus it would go unnoticed by historical linguistics. The norms for pronunciation are distributed in the minds of all the speakers of the community; it is surely a rare occasion when one individual's changed norm

influences the rest of the population. Mini-sound changes become “maxi-” sound changes at a very low rate and this is the reason that, by and large, pronunciation changes so slowly over the centuries in spite of the variability that can be seen in the speech signal. Nevertheless, the sound changes that have been documented in the histories of languages are drawn from a pool of synchronic variation (Ohala 1989).

2.7 *Assimilative and dissimilative sound changes*

The preceding account of sound change, I believe, applies to the vast majority of common sound changes considered to be assimilative, that is, where a previously phonetic, purely mechanical, coloring of a sound by another contextual sound becomes independent of that context and is articulated in its own right. This is the process commonly known as “phonologization” (Hyman 1976; Jakobson 1931). Examples are the nasalization of vowels near nasal consonants, the palatalization of consonants near palatal vowels and glides, the development of tones due to consonantal influence, vowel harmony, changes in vowel quality due to nasalization, changes in vowel quality due to adjacent consonants, stop epenthesis, etc. However, still unexplained is a large class of sound changes characterized as dissimilative, that is, where two sounds sharing one or more phonetic features change such that they become less similar to one another (or, in some cases, where one of the sounds disappears). To be sure, dissimilation is far less common than assimilation – to the point that some phonologists seem unwilling to characterize it as a “natural” sound change or at least on a par with the rest (Bloomfield 1933: 390; Hock 1986: ch. 6; Schane 1972) – but it is nevertheless a well-documented type of sound change. Given the account above of assimilative sound change, dissimilation would seem to present a problem: we can give phonetic reasons why a sound will take on features of adjacent sounds, but why should a sound become less like adjacent ones?

In fact, we have reviewed above reasons why this might happen. In “normal” speech perception, when the listener correctly figures out the pronunciation intended by the speaker, the listener has had to use some cognitive strategies to normalize or correctly parse the variable signals received from the speaker. Assimilative sound change occurs when the listener fails to make that correction. Dissimilative sound change can happen when the listener inappropriately implements the correction or normalization. For example, in Russian a low front [a] has become [ɑ] near palatal segments, for example, /stoj + ā/ > /stojā/ ‘standing’ (Darden 1970). Listeners probably expected that vowels would be fronted near palatal consonants and so discounted this contextual effect and mistakenly created a pronunciation norm where the vowel was back.

There is laboratory evidence that listeners do this kind of “hypercorrection” on occasion. Beddor et al. (1986), found that under certain conditions listeners identified *more* of the /ɛ̃n/-/æ̃n/ continuum as /ɛ̃n/ (vis-à-vis the /ɛd/-/æd/

continuum) when there was slight nasalization on the vowel. Further evidence for hypercorrection was presented by Ohala and Busà (1995). Dissimilative sound changes, like the assimilative ones, involve listener error; it is just a different kind of error.

2.8 *Terminology*

In other works (Ohala 1992a, 1993a) I have referred to the perceptual processes which normalize or “correct” the kind of coloring that one speech sound imposes on another, that is, when the listener correctly deduces the signal intended by the speaker, as “correction.” This applies to the vast majority of exchanges between speaker and listener. The errors of perception, then, are of two types. One is “hypocorrection,” where the listener fails to implement the corrective strategies and takes the contextually distorted speech signal at face value. These errors underlie the vast majority of sound changes which are commonly labeled “assimilative” (but also underlie other sound change types, too; see below). The dissimilative sound changes (and others based on listener expectations) are those that arise due to listeners’ inappropriately applying corrective processes I have termed “hypercorrection.”

2.9 *Evidence supporting the claim that dissimilation is perceptual hypercorrection*

There is evidence in favor of this account of dissimilation.

2.9.1 *Which features are subject to dissimilation*

First, it is possible to predict which features are and which features are not likely to be subject to dissimilation. Dissimilation, especially, dissimilation “at a distance,” such as Grassmann’s law, which affects segments that are separated by others which are unaffected by the change, should occur primarily on features whose acoustic-perceptual cues are known to spread over relatively long time intervals beyond the immediate “hold” of the segment they are distinctive on. This includes aspiration, glottalization, retroflexion, palatalization, pharyngealization, labialization, etc. These are most likely to color adjacent segments and require the listener to “undo” their effects. When the same feature occurs distinctively on two sites within a word, their long distance diffusion creates maximal ambiguity for the listener. Segments whose distinctive features do not migrate substantially in time should not be subject to dissimilation. This includes the features that cue stops, affricates, and voicing.⁶ Although there are apparent problem cases that need further discussion and examination, such as laterals and fricatives,⁷ my own survey of the historical phonology literature seems to support the above predictions (see Ohala 1981a, 1992a).

2.9.2 Preservation of the conditioning environment

Second, based on this account of sound change, different predictions can be made as regards the fate of the conditioning environment in assimilative and dissimilative sound changes. In assimilative changes, the conditioning environment may be lost; indeed, if the listener fails to detect the conditioning environment, this is a transparently obvious reason for the listener to fail to take into account how that environment might have influenced the target sound. Thus sound changes of the following sort are common:

- (3) an > ã
 sia > ja
 pa, ba > pá, pà

This is not to say that all assimilative sound changes lose their conditioning environment. Vowel harmony is a well-known example where the conditioning environment remains. All I am pointing out here is that the environment *may* be lost in such changes. What is common to cases of hypocorrection where the environment is lost and where it is not lost is that the listener fails to establish any causal link between the conditioning environment and the conditioned variation.

In dissimilative sound changes, however, the environment may *not* be lost *at the same time* as the change in the target segment or feature. The reason obviously is that the conditioning environment must be detected by the listener in order that he or she blame that environment for what is thought to be a distortion on an adjacent segment. Specifically, what is predicted not to happen is a hypothetical variant of the dissimilation of the /w/ that was part of the historical development of the word for 'five' in various Romance languages, in contrast to the normal retention of the /w/ in other cases as in (4):

- (4) What happened: kwiŋkwe > kiŋkwe (subsequently > tʃiŋkwe)
 But: kwi > kwi
 What may *not* happen: kwiŋkwe > kiŋke
 But: kwi > kwi

As far as I am aware, this prediction is borne out; dissimilative sound changes invariably retain the conditioning environment, at least in the earliest stages of their development.

2.9.3 Dissimilation doesn't produce novel segments

With assimilative sound changes it may be possible to create novel contrasts or sound sequences; for example, when French and Hindi acquired distinctively nasal vowels after loss of adjacent nasal consonants, the nasal vowels represented additions to the vowel inventory. With dissimilative sound changes, this

seems not to be the case. The result of dissimilative sound changes appears, in general, to be segment types or sequences that were already present in the language. Dissimilative changes are thus “structure preserving.” This follows from the fact that it is listeners’ *normalization* of what they imagine to be a distorted signal that leads to dissimilation.

2.9.4 *The domain of dissimilation is the word*

There is additional evidence supporting my account of dissimilation based on the typical domain over which dissimilation applies. As background for this it is useful to note that prior explanations for dissimilation have often invoked the concept of “ease of articulation,” for example, that in Grassmann’s law where two aspirates in a word results in the first one becoming deaspirated, it has been claimed that speakers tried to avoid the cost of articulating two such physiologically costly segments in a row (Müller 1864; Ladefoged 1984). That explanation would be plausible except for two facts which don’t fit. First, as mentioned above, it is usually the *first* of the two aspirates which undergoes deaspiration, whereas cost is a cumulative function and would be expected to be higher on the *second*. If articulatory cost was being trimmed, the motivation to do this would be expected to affect the second, not the first, aspirate. Second, if such physiological cost matters then dissimilation would be expected to occur on any two sequential aspirates that occur in utterances, even those which occur in separate successive words. This is not the case, however; Grassmann’s law and other dissimilations occur only within the domain of the word (or possibly, in lexicalized compounds). A word, by definition, is a fixed collocation of speech sounds which, by their combination and permutation, signal different meanings. For example, in the word ‘leg’ the vowel [e] is permanently colored by the preceding [l] and by the following [g]. This presents the listener with the maximum ambiguity as to what the intended quality of the vowel is and, as it happens, this word is realized dialectally as [leɪg], where, apparently, listeners parsed some of the [g] onglide as a diphthongal ending to the vowel. In contrast, elements that are freely permutable offer listeners the opportunity to hear that sound in many different phonetic environments and thus enables them to factor out the contextual distortions more easily. The fact that most sound changes occur within words or within common phrases that may be lexicalized is an argument that sound change – assimilative as well as dissimilative – is not related to physiological cost but is primarily a parsing error on the part of the listener.

2.10 *Other sound change types*

So far I have tried to make the case that common assimilative and dissimilative sound changes arise from listeners’ perceptual parsing errors. Is there any possibility that other types of sound change could likewise be shown to be

due to parsing errors? Much work still needs to be done, but I think it is at least plausible that this is the case. It is certainly not possible yet to present anything like a complete argument on this point, but I can at least share the reasons for my optimism.

2.10.1 *Metathesis*

Metathesis, the interchange of nearby speech sounds, comes in various forms. For example, Old English (OE) *clapse* has given rise to Modern English (ModE) *clasp*; OE *hros* to ModE *horse*. Blevins and Garrett (1998) have recently presented arguments that vowel-consonant metathesis comes about from listeners' misparsing of the speech signal in a way similar to that which I have posited for dissimilation. Consonant-consonant metathesis of the sort *clapse* ~ *clasp* in a great many cases across diverse languages involves interchanges between adjacent stops and some kind of noisy segment; cf. also Sanskrit *hasti* 'elephant' and Prakrit *hat^hri*, where, it seems, the distinctive aspiration is the heir, after metathesis, to the earlier /s/. There may be a psychoacoustic basis for this. Warren (forthcoming) presents evidence that, when presented with sequences of speech-like sounds with typical speech sound durations, listeners cannot readily "unpack" the order of the sounds but rather hear the sequence in a holistic way.

2.10.2 *Epenthesis*

A wide variety of consonant epenthesis, as in table 22.4, can readily be accounted for in terms of fortuitous overlap or coarticulation of both of two articulatory "valves" which are separately associated with the production of two adjacent segments. For example, in the case of [ls] > [lts], the first segment [l] requires tongue-palate contact at the midline but no contact at at least one side; the second segment, [s], requires the reverse: tongue-palate contact at both sides but not at the midline. In the transition between these two segments, when coarticulation may occur, both of these contact patterns may overlap, thus creating a complete stop. (See Ohala 1974, 1995a, 1997, forthcoming, for further details.)

2.10.3 *Elision*

Many forms of elision (apocope, syncope, procope) can plausibly be traced to some speech segments being obscured by others. Browman and Goldstein (1988), for example, demonstrate how, in one speaker's utterance of the phrase *perfect memory*, phonetically [p^hæ:fekt 'mɛm.ɹi], the final /t/, although articulated, was not evident in the acoustic signal because it was obscured by the overlap of the /k/ and /m/ articulations. Such cases present listeners with little or no evidence of the obscured segment and can thus lead them to form a novel pronunciation norm. Similarly, it is not difficult to imagine that brief,

Table 22.4 Types of epenthesis that can be explained phonetically

Environment of epenthesis	Language	Form showing epenthetic stop	Source
Nasal __ oral obstruent	English	<i>Thompson</i>	<i>Thom + son</i> (proper name)
Oral obstruent __ nasal	Sanskrit	viṣṭṇu-; biṣṭu	viṣṇu- 'Vishnu'
Nasal __ oral non-obstruent	Latin	<i>templum</i>	*tem – lo 'a section'
Homorganic lateral __ fricative	English	[ɛlts]	<i>else</i>
Homorganic fricative __ lateral	Latin > Italian	[iskja] <i>Ischia</i>	iskla < istla < isla 'island'
Ejective < stop __ [ʔ]	Chumash	k'ap 'my house'	k + ʔap 1st pers. + 'house'
Labial nasal __ coronal nasal	Landais French	<i>fempne</i>	<i>femina</i> 'woman'

weakly articulated, vowels seemed ambiguous to listeners, consistent as well with no vowel or with simple release of a preceding consonant. This would explain such cases as the loss of unstressed penultimate vowels in the development from Late Latin to Early French, for example, *pĕrdĕre* > *pĕrdre* 'to lose,' *simĭlo* > *sĕmble* 'seem' (Pope 1934: 112).

2.10.4 "Automatic" vowels near tap and trill /r/'s

Ohala and Kawasaki-Fukumori (1997) consider the case of the appearance and disappearance of vowels between tap and trilled *r*'s. For example, obstruent *r*'s such as [ɾ, r, ʀ] consist of abrupt amplitude modulations of a vocalic carrier signal (see Ladefoged and Maddieson 1996: 218). Without the carrier signal, they could not exist. Often, when such *r*'s are in clusters with other consonants, pre- or post-vocalic, a brief part of the vocalic carrier signal will intervene between them. This so-called "automatic vowel" has been well studied in Spanish (Gili Gaya 1921; Navarro Tomás 1918; Quilis 1970). It can happen that this brief vocalic element is misparsed by listeners as a full, intended, vowel, not as a carrier of the *r*. Menéndez-Pidal (1926: 217–18) provides examples (dial.) such as *corónica* (< *crónica*, 'chronicle') and *p^rredicto* (< *predicto* 'I predict').

Similarly, when a full vowel becomes short and is flanked by an r and another consonant, it might be parsed by listeners as this automatic vowel and thus discounted.

3 Discussion: The Implications of the Above Account of Sound Change

There are a number of implications of the above account of sound change:

- First, sound change, at least at its very initiation, is not teleological. It does not serve any purpose at all. It does not improve speech in any way. It does not make speech easier to pronounce, easier to hear, or easier to process or store in the speaker's brain. It is simply the result of an inadvertent error on the part of the listener. Sound change thus is similar to manuscript copyists' errors and presumably entirely unintended. I leave unaddressed the separate question of whether, after its initiation, the success of a sound change's transmission and spread may be influenced by teleological factors (but see Lindblom et al. 1995 for a discussion of this issue). (See Ohala 1995c for a discussion of phonetic factors in the spread and extension of a sound change.)
- Second, as a correlate of the above: the "change" aspect of sound change is not mentalistic and thus is not part of either the speaker's or the listener's grammar. Language change results in grammar change but it is not caused by the grammar, where "grammar" means the psychological representation of language. There is, to be sure, much cognitive activity – teleology, in fact – in producing and perceiving speech, but all the evidence we have suggests that this is directed toward *preserving*, not replacing, pronunciation norms.

The theoretical literature on sound change contains many claims to the contrary: that sound change improves communication, that it is implemented by altering the grammar, etc. (e.g., Jespersen 1894; Kiparsky 1968; King 1969; Martinet 1952; Vennemann 1993; Lindblom et al. 1995). It is not my purpose to attempt a detailed refutation of these arguments: I am simply presenting an alternative view and marshaling evidence in support of it. But I proffer one comment on the arguments offered to show that language change is directed toward some goal: any of several aspects of language can be cited as showing some improvement due to a given change: the size of the phoneme inventory, the symmetry of the inventory (or lack of it), the phonotactics, the canonical shape of syllables, morphemes, or words, the opacity of morphologically related forms, the loss or addition of inflectional affixes, the structure of the lexicon, the functional load of certain elements, etc., etc. With so many "degrees of freedom"

to invoke, where is the rigor in finding some area of alleged improvement following a specific change? What is the null hypothesis which the improvement arguments are competing against? I suspect it is not possible to fail to find some feature which one can subjectively evaluate as an “improvement” following a given sound change. But the lack of rigor in marshaling the evidence makes such accounts less interesting.

In contrast to the subjectively based teleological accounts of sound change, the phonetically based account of sound change presented here does offer the possibility of rigorous testing in the laboratory; see below:

- Third, this account identifies the *listener* as having the lead role in sound change. This is in contrast with almost two centuries of speculation on the causes of sound change which focused on the speaker. To be sure, the speaker is responsible for much of the phonetic variation seen in speech, but it has been shown in speech perception studies that listeners are normally successful in parsing this variation to its proper sources. Variability created by the speaker makes the speech signal ambiguous to the listener, but it is the listener who inadvertently makes the error in (re)constructing the pronunciation norm.
- Fourth, this account permits a full integration of the cumulative results of phonetic studies with those of historical phonology. The remarkable parallels between synchronic and diachronic variation are explained. One of the most important aspects of the comparative method is establishing likely *paths*, that is, sound changes, between one posited state of a language and another. Phonetics can assist in evaluating alternative paths. The benefits of this integration do not flow in just one direction, that is, from phonetics into historical phonology. The cumulative results from historical phonology, that is, descriptions of the historical development of numerous languages, represent, I think, a vast treasury of data that, if interpreted properly, provides hints on the workings of speech (Ohala 1974, 1993b). Following these leads can benefit many areas of applied phonetics, from language teaching to speech technology (synthesis and recognition of speech).
- Perhaps the most important aspect of this view of sound change is that it shows how sound change can be studied in the laboratory. Fine-grained studies of the articulatory and acoustic details of speech can show the source of variability and thus perceptual ambiguity in the speech signal. Speech perception studies can show how listeners accommodate this variability. Listeners’ perceptual errors constitute what I have called “mini-” sound changes. From such studies it may even be possible to give a principled rank ordering of sound changes according to their likelihood.
- In historical phonology there has long been a quest to answer this question: “[w]hy do changes in a structural feature take place in a particular language at a given time, but not in other languages with the same feature, or in the same language at other times?” (Weinreich et al. 1968: 102). I suggest that as far as the initiation of sound change is concerned, this question may be

unanswerable and not worth pursuing. If sound change is equivalent to listeners' errors, then the question reduces to "why did listeners (or a listener) of a particular language misparse the speech signal at a given time but not speakers of other languages, etc.?" Given inherent ambiguities in speech, there is some probability in any and all languages at any and all times that certain misperceptions, that is, mini-sound changes, will occur. It is rather a question of which of all the mini-sound changes that crop up constantly are for some reason "selected" via psychological and social factors to be copied by other speakers. The answer to the "why this language at this time?" question lies in the transmission, not the initiation, of sound change.⁸ I think it will be extremely difficult to get a rigorous answer to this question for a specific sound change.

- Since the early days of generative linguistics, the grammars that speakers acquire as they learn a language have been claimed to be simple. This was because grammatical rules are supposed to be general and generality correlates with simplicity. Feature-counting or the quantitative measure of what's general gave way in 1968 (Chomsky and Halle 1968) to a qualitative measure of generality, namely, rules and the grammars that contained them were evaluated according to their degree of (un)markedness or naturalness or expectedness. Unmarked or natural phonological processes such as "the obstruents device" (versus the marked or unnatural process "obstruents voice") were preferred. Since that time many other devices have been introduced to insure that grammars were natural. In phonology this typically means "phonetically natural." But it was just determined by decree that grammars were simple or general and similarly it was by decree that naturalness was made a desirable property of mental grammars. But this conception needs re-examination. The question is: can native speakers differentiate between phonetically natural and phonetically unnatural processes in the sound patterns in their language?

The phonetically-based account of sound change given here provides a sufficient account of how natural rules get into a language. But no one could seriously maintain that the native speaker is (i) aware of the history of her or his language and (ii) aware of the physical processes (Boyle's law, fluid dynamics, etc.) that govern these processes. So the phonetic primitives invoked in the modeling of these processes make no pretenses of being psychological. The attempts by those who are interested in psychological phonological grammars and in finding ways to represent phonological processes (the results of sound change) in phonetically natural ways have been abysmal failures (Ohala 1995b). One possible solution to this is not to put more phonetic sophistication into psychological grammars but rather to abandon phonetic naturalness as a necessary feature of them.

In any case, I think it is time that the question of the site of phonetic naturalness in languages' sound patterns be re-examined. I take it as demonstrated that historical grammars of language should have phonetic naturalness; it is not clear that psychological grammars need it.

ACKNOWLEDGEMENTS

For helpful comments on earlier drafts, for collaboration on some of the studies cited here, and for bibliographic leads, I thank Mariscela Amador, Steve Greenberg, Haruko Kawasaki-Fukumori, Manjari Ohala, Madelaine Plauché, and Maria-Josep Solé.

NOTES

- 1 See Ohala (1991, 1996) for an elaboration of the term “scientific phonetics.”
- 2 But see Darwin (1803: 119).
- 3 Although it is difficult to prove, I have the impression that native speaker linguists report less allophonic variation in their language than do linguists who are not native speakers of the language. If so, there is an explanation for this which is also highly relevant to an understanding of sound change. I return to this point later.
- 4 Regarding the asymmetry in the direction of confusion and in the direction of many sound changes, see Ohala (1983a, 1985a, 1997); Plauché et al. (1997).
- 5 The claim that sound change is due to listeners’ errors is hardly original; see Bredsdorff (1821); Passy (1890); Anderson (1973); Allen (1951); Durand (1955); von Essen (1964); Jonasson (1971); among others. Where my approach differs is that I claim that listeners’ errors constitute the main and the essential factor in sound change (assuming sound change is taken as “new pronunciation norm”) and that I marshal phonetic evidence in support of the claim.
- 6 “Voice” is included in this list because its primary cue is presence or absence of periodic excitation during the voiced segment itself – the periodicity does not “spread.” For physiological, especially aerodynamic, reasons, voicing may be assimilated by segments adjacent to other voiced segments, but it doesn’t follow from this that the perceptual cues for voicing have spread.
- 7 Laterality, per se, does not spread onto adjacent non-lateral segments and so would be expected not to be subject to dissimilation. Nevertheless, it is well known to dissimilate, for example, in the case of the suffix *-alis/-aris* in Latin: *universalis* but *militaris*. However, the acoustic-perceptual cues for laterals include relatively long spectral transitions and these probably account for their occasional dissimilation. Frication, like voicing, is perceived via the relative periodicity of the speech signal in a very short time interval. It is predicted not to be subject to dissimilation.
- 8 There may be phonetic factors at play in the spread of some sound changes; see Ohala (1995c).

23 Contact as a Source of Language Change

SARAH GREY THOMASON

In a sense, most of what historical linguists study under the designation “language change” is due to contact. An individual speaker’s innovation typically becomes part of the database of historical linguistics only after other speakers have adopted it – both because the likelihood that any historical linguist will become aware of one person’s innovation is minute and because the innovation may well be ephemeral even for the single innovator. The changes we investigate therefore tend to be those that have spread throughout a speech-(sub)community, and the process of spread is a function of contact between speakers. Nevertheless, the spread of innovations within a speech community has traditionally been considered separately from the diffusion of features across dialect and especially language boundaries.¹

One reason for this separation is that quite different methodologies for studying these two kinds of contact have developed (compare, for instance, this chapter and the following one, by Wolfram and Schilling-Estes). Another reason, which is of course related to the first, is a commonly perceived difference in the nature of the processes: dialect borrowing (and indeed diffusion of features from any one speaker of a given dialect to any other speaker of the same dialect) has generally been considered, at least implicitly, to be primarily a social process, mostly or entirely unconstrained by linguistic factors. The transfer of features from one language to another, by contrast, has been the subject of numerous proposed linguistic constraints, and social factors have often been treated as secondary. The intuition underlying this distinction is that two dialects of the same language, and certainly any two speakers of the same dialect, share most of their lexicon and grammatical structures, so that a neighbor’s innovation will be easy to learn (and adopt) and unlikely to disrupt the original linguistic system seriously; but separate languages, since they differ in more fundamental respects than dialects of the same language, would risk undergoing disruptive change if their speakers adopted features promiscuously from other languages, and in addition such features would be harder to learn (and thus harder to adopt). There is also a common assumption

that speakers of dialects of the same language are more likely to talk to each other than to speakers of different languages; so social contact is often assumed as a given in dialectology, whereas it must be established by argument and evidence to support a claim of change induced by contact with another language.

These intuitions and assumptions are not wholly mistaken, but the differences turn out to be a matter of degree, not of kind. Dialects of the same language may have particular structure points that are more different than analogous structures in related or even unrelated languages; in many speech-communities, contact with other languages is more frequent than contact with geographically distant dialects of the same language; and so forth. This means (among other things) that both linguistic and social factors must be considered in any full account of contact-induced change, regardless of whether the contact is between dialects or separate languages. More generally, both social and linguistic factors must in principle be considered in any full account of any linguistic change, although in practice we have little or no social information about the vast majority of changes we know about. For this reason, and also because the following chapter covers dialectological aspects of the general topic, I will focus here primarily on what has traditionally been studied as contact-induced language change – namely, the linguistic results of contact between two (or more) languages.

Before turning to particular aspects of the general topic, I should clarify my use of terms. In my view, contact between languages (or dialects) is a source of linguistic change whenever a change occurs that would have been unlikely, or at least less likely, to occur outside a specific contact situation. This definition is broad enough to include both the transfer of linguistic features from one language to another and innovations which, though not direct interference features, nevertheless have their origin in a particular contact situation. The most obvious examples in the second category are those changes in a dying language that do not make the dying language more similar to the dominant language (see section 3 for discussion). I usually use the terms “(linguistic) interference” and “contact-induced change” interchangeably; but this usage requires a caveat, because non-convergent simplifying innovations in a dying language are certainly contact-induced, though they are not interference features. Less obvious but still important examples are innovations that appear at a late stage of a chain-reaction process in which an initial instance of structural transfer sets off a series of other changes. In such cases the end result may well be more radical structural change than the first step, but the ultimate source of the drastic result nevertheless lies in that initial transfer. The late-stage innovations are therefore still contact-induced changes, but they are not interference features *per se*.

The notion of feature transfer should also be construed broadly: it includes innovations based on reinterpretation of source-language features by the speakers who implement the changes as well as the introduction of features

actually present in the source language. All these are interference features in the receiving language.

A final observation, though not a definition, is also needed to set the stage for the discussions that follow. On occasion I will refer to the sociolinguistic notion “intensity of contact” as a requirement for certain degrees and kinds of interference. This is a vague notion, but it is difficult to pin down more precisely in a way that applies to a wide range of contact situations; among the factors that contribute to greater intensity of contact are a high level of bilingualism, socioeconomic and/or political pressure on one speaker group in a two-language contact situation to shift to the other language, length of contact, and relative sizes of speaker populations. The point I wish to make in connection with intensity of contact is this: great intensity of contact is a *necessary* condition for certain kinds of interference, especially structural interference, but it is by no means a *sufficient* condition. It is easy to find contact situations in which, despite (for instance) great pressure on and universal bilingualism among speakers of one language, very little contact-induced change of any kind has occurred. One such example is Montana Salish (also called Flathead), a Salishan language spoken in northwestern Montana. Of the several thousand tribal members, fewer than 70 fluent speakers of the language remain, and all of them have native fluency in English as well as in Montana Salish. Nevertheless, the English intrusion into Montana Salish is minimal: a few loanwords – some of them dating back to the nineteenth century, when few if any tribal members spoke English – and no detectable grammatical influence of any kind. Nor are there any visible signs of language attrition; in particular, all the elaborate morphological structure of the language is intact. The general conclusion is obvious: as with internally motivated change, predicting when contact-induced change will occur is at best risky.

In section 1 I discuss various types of linguistic interference: a classification of the changes in terms of their effects on the receiving system; a fundamental dichotomy between changes in which imperfect learning plays a role and changes in which it doesn't; and linguistic factors that affect the likelihood that a feature will be borrowed. Section 2 surveys mechanisms of interference, section 3 concerns the relationship between linguistic interference and changes that occur in language death, and section 4 compares contact-language genesis with contact-induced language change. I conclude in section 5 with a brief discussion of retrospective issues – in particular, how can one “prove” that a particular linguistic change is due to language contact? – and a summing up of the entire chapter. Throughout this chapter the discussion and examples will focus on two-language contact situations rather than on multilanguage situations such as those characteristic of Sprachbund contexts. The reason for this focus is that basic processes and results, as well as their correlations with social factors, are much easier to isolate in less complex situations (see section 2 for further discussion of this point).

1 Types of Linguistic Interference

There are of course many possible ways of classifying the results of linguistic interference. In this section I will discuss the three classifications that are most generally relevant to understanding the nature of contact-induced change – differing results in terms of effects on the receiving system, differing types of interference resulting from different social conditions, and differing types of interference resulting from the influence of various linguistic factors.

1.1 Systematic effects on the recipient language

First, changes may be categorized according to their general effects on the receiving language's structure: old features may be lost from the system, new features may be added to the system, or old features may be replaced by new ones. Not all changes fit neatly into one category or another, since some involve partial loss with partial replacement and others involve partial addition with partial replacement; but these three categories cover the basic possibilities.²

Here are typical examples of the three types. Romansh has lost gender agreement in predicate adjectives under German influence (Weinreich 1953: 39), and both Kupwar Marathi and Kupwar Urdu have lost gender agreement in noun modifiers under Kannada influence (Gumperz and Wilson 1971; see Thomason and Kaufman 1988: 86–7 for discussion). The simplest examples of added features are lexical borrowings where both form and content are new to the borrowing language, such as English *bok choy*, but structural features are also often added via borrowing. For instance, Kupwar Urdu has acquired an inclusive/exclusive “we” distinction from Marathi (Gumperz and Wilson 1971), and vowel harmony has been introduced into Greek suffixes in some Asia Minor Greek dialects (Dawkins 1916: 47, 68). An example of replacement is the appearance, in an Asia Minor Greek dialect of Cappadocia, of the Turkish inflectional suffixes *-ik* ‘1pl.’ and *-iniz* ‘2pl.’ replacing the corresponding Greek suffixes on Greek verbs (Dawkins 1916: 144).

It is worth noting that these three results are also basic categories in internally motivated linguistic change; here, as in certain other important respects, the main difference between the two lies in their sources, not in anything special about the change processes themselves. So, for instance, we find feature loss in cases where there appears to be no external motivation, as in the loss of the distinction between the dative and locative cases in some Serbo-Croatian dialects. Internally motivated feature addition includes, among other things, discourse markers such as *like* in *She's like, “What are you doing here?”*

In both internally and externally motivated change, feature replacements are always complex processes, involving competition between the original form or construction and the innovative feature. For internal changes this competition is explored in (for instance) Bloomfield's chapter on “Fluctuation

in the frequency of forms" (1933: 392–403) and embodied in Kuryłowicz's fourth "law" of analogy (1945–9: 30), according to which competing forms that arise through analogic split undergo semantic differentiation if they both remain in the language (with the innovative form taking over the basic function, thus justifying calling it a partial replacement). Somewhat parallel examples with internal and external sources can be adduced. Compare, for instance, the partial internal analogic replacements in *hanged* versus *hung* (with semantic differentiation) and *dived* versus *dove* (without semantic differentiation) with partial replacements through borrowing, such as the borrowed/native words *animal* versus *deer* (with semantic differentiation) and the competition between borrowed and native inflectional material in Cappadocian Greek, where Turkish suffixes are not used on all Greek verbs all the time.

1.2 *Interference with and without imperfect learning*

The second especially important classification of types of linguistic interference focuses on a robust correlation between one prominent sociolinguistic variable and divergent sets of linguistic results. The sociolinguistic variable is the presence versus the absence of full, or at least extensive, fluency in the recipient language. That is, the crucial factor is whether the people who introduce the interference features speak the language into which the features are introduced – or, in other words, whether imperfect learning plays a role in the interference process. When fluent speakers of language A incorporate features into A from another language, B, the first and most common interference features will be non-basic lexical items, followed (if contact is sufficiently intense) by structural features and perhaps also basic vocabulary. This pattern – (non-basic) vocabulary first, structure later if at all – is at the foundation of most of the borrowing scales that have been proposed in the literature (e.g., Moravcsik 1978: 110 and Comrie 1981: 202ff; see Thomason and Kaufman 1988 for discussion). By contrast, if people who are not fluent speakers of A introduce features into A from another language, B, the first interference features (and usually the most common ones overall) will not be lexical, but rather phonological and syntactic. Morphological features may also be introduced under this condition; the likelihood that lexical items from B will be incorporated into A depends on other social factors, such as the relative prestige of A and B speakers.

These two types of interference were characterized in Thomason and Kaufman (1988) as *borrowing*, in which features are incorporated into A by native (L1) speakers of A, versus *shift-induced interference*, in which a group of L2 learners of A carry over features from B (their L1) into A during a process of shift from B to A. Independently, in the same year, van Coetsem (1988) proposed a nearly identical distinction, labeling the two types *recipient language agentivity* (or *borrowing*) versus *source language agentivity* (or *imposition*). These two formulations are adequate for most cases, but not for all: in particular, borrowing may be carried out by fluent L2 speakers of A; "shift-induced

interference" sometimes occurs when no shift takes place at all – in cases where, as with English in many parts of the world, local varieties of a language arise and stabilize but remain second languages; and part of an "imposition" process may involve the participation of A speakers (see below for discussion).

Moreover, the role played by imperfect group learning of a target language (TL) is more complex than the definition of shift-induced interference allows for. If shifting speakers do not learn the TL perfectly, their version of the TL (TL₂) will differ from the native speakers' version (TL₁) in two ways: first, the learners will fail to learn some features of the TL, usually features that are hard to learn for reasons of universal markedness or typological distance from the structure of their L1, or both; and second, they will carry over features from their L1 into the TL. In the latter case the term "imperfect learning" may be misleading: in some instances the learners may well know that the particular L1 features do not exist in the TL, but they may nevertheless introduce them into their TL₂ in order to maintain an L1 distinction that is lacking in the TL₁. The learners' TL₂ may stabilize as a variety exclusive to the shifting group and their descendants; this happens if there is sufficient social and/or geographic isolation from the main TL₁ community to permit, encourage, or necessitate maintenance of the TL₂ without linguistic integration. But sometimes TL₂ speakers become part of the TL₁ speech-community, with linguistic integration. In such a case TL₁ speakers may borrow features from TL₂, thus producing an integrated variety, TL₃; this process is of course borrowing in the narrow sense of Thomason and Kaufman (1988), but the interference features are nevertheless those characteristic of shift-induced interference – both because the innovations (from the perspective of TL₁) will be a subset of the innovations of TL₂ and because TL₁ and TL₂ already share a common lexicon.

For all these reasons, the formulation of the distinction in Thomason and Kaufman (1988) needs two revisions: the crucial sociolinguistic factor is not whether or not shift takes place, but whether or not there is imperfect learning by a group of people;³ and one half of the linguistic prediction must be hedged – in borrowing, interference always begins with non-basic vocabulary unless languages A and B have mostly or entirely identical lexicons. Unfortunately, the first revision leaves us with no convenient and fully accurate term for what has been called shift-induced interference; to avoid proliferating terms I will continue to use it, in the hope that readers will not find its literal inaccuracy too jarring.

Finally, it must be emphasized that the picture presented in this section takes the simplest case as basic. Many cases are considerably more complicated. One complication is that the two types of interference often co-occur in the same contact situation: shift-induced interference may be implemented (in the first instance) by shifting speakers even while original TL speakers are borrowing features directly from the shifting group's language (not from TL₂). The other obvious complication is that more than two languages may be involved, with varying mixes of borrowing and shift-induced interference going on at more or less the same time. These are the cases usually labeled as

Sprachbund situations, where a number of languages in a particular region share a set of features that distinguish them from their respective sister languages in other regions. Probably the most famous Sprachbund areas are the Balkans (see, e.g., Sandfeld 1930; Schaller 1975; Joseph 1983a) and India (see, e.g., Emeneau 1956), but these are by no means the only examples; among the others that have been discussed in the literature are Arnhem Land in Australia (Heath 1978), the Pacific Northwest of North America (e.g., Jacobs 1954; Thompson and Kinkade 1990), and Meso-America (Campbell et al. 1986).

As a result of such complications – and in particular because even shift-induced interference often includes lexicon, and contact situations in which group shift is taking place sometimes include simultaneous two-way interference – the retrospective picture may be difficult or impossible to unravel. Only two safe predictions can be made. If, for a past contact situation, it can be established that contact-induced change occurred, and if phonological and syntactic interference predominate, then imperfect learning must have been a major factor in the process of interference. In contrast, if mainly or only lexicon has been transferred from B to A, then imperfect learning is unlikely to have played any significant role in the process. But if sizable amounts of both lexical and structural interference can be demonstrated, it is likely to be impossible to tell, from the linguistic evidence alone, whether or not imperfect learning played a role.

1.3 *Linguistic factors in linguistic interference*

Interference features can easily be found in all linguistic subsystems – phonetics, phonology, morphology, syntax, lexical semantics, discourse, and even narrative structure – under the appropriate social circumstances. The appropriate social circumstances include, besides the presence or absence of imperfect learning, the crucial but hard-to-define factor of intensity of contact: the more intense the contact, the more kinds of linguistic features can turn up as interference features. The probabilities are not the same for all subsystems, however; the linguistic factors of universal markedness and typological distance between source and recipient language are important in predicting what kinds of features will be transferred from one language to another. This is especially obvious in shift-induced interference because, as noted above, these factors contribute to the learnability of particular features in particular contact situations: TL₁ features that are harder to learn are less likely to be learned by shifting speakers, and TL₂ features that are harder to learn are less likely to be learned and borrowed by original TL speakers.

The usefulness of borrowing scales attests to the relevance of linguistic factors in borrowing (in my narrow sense) as well, but here the focus shifts from learnability per se to the degree of integratedness into a linguistic system, as emphasized by Heath (1978) and Comrie (1981), among others. Features that are deeply embedded in elaborate interlocking structures are in general less

likely to be borrowed, because they are less likely to fit into the recipient language's structures; that is why the lexicon, which for all its structure is less highly organized than other grammatical subsystems, is borrowed first, and it is why inflectional morphology tends to be borrowed last. But highly integrated features may be borrowed readily between systems that are typologically very similar; that is why, in dialect borrowing, even inflectional morphology is quite easily transferred. Other factors also enter in, though they are harder to specify; for instance, the significant difference in borrowing probability between basic vocabulary (less often borrowed) and non-basic vocabulary (more often borrowed) must depend on something other than degree of internal organization.

And when contact is intense enough, there appear to be no absolute linguistic barriers at all to borrowing (see section 2.7 below for discussion).

2 Mechanisms of Interference⁴

If we ask how contact-induced change comes about, we find that the actual processes parallel processes of internally motivated change to a considerable extent. In both types we must consider the competition between old and new variants, the role of markedness (or, more generally, ease of learning) in helping or hindering the spread of an innovation, the effects of analogic leveling and extension, and the role of speakers' creativity in producing and stabilizing innovations. I will not emphasize these parallels here, but a fuller treatment of processes of linguistic change would necessarily explore them.

Mechanisms of contact-induced change fall into four categories. Two of them correlate with the distinction between borrowing and shift-induced interference: one set of mechanisms comes into play when the implementers of a change are bilingual in both source and recipient language (sections 2.1–2.3, and in a sense section 2.6), while the other set comprises second language acquisition strategies (section 2.5). A third category, "negotiation," seems to overlap with both of these types (section 2.4), and the fourth category has to do with more or less conscious and deliberate decisions by speakers to implement language change (section 2.7).

Before beginning the survey of mechanisms, I should make two background assumptions explicit. First, any feature that can be code-switched from language A into language B can turn into a permanent interference feature in B, and the same is true for all the other mechanisms. More generally, any feature that can appear in a single person's speech at any time – for example, in speech errors caused by fatigue or drunkenness or mere carelessness – can turn into a permanent change in the entire language; it is ultimately irrelevant whether the source of the feature is internal or external. In other words, the question of linguistic possibility is settled as soon as a feature appears for the first time anywhere. This assumption is exploited below in various examples of individuals'

linguistic behavior, which I take to be valid illustrations of what can happen in language change. Predicting whether a given one-time innovation will become a permanent part of a person's speech or of an entire language is of course a different question entirely, a matter of probabilities in the complex interplay of linguistic and social factors. If correct, this assumption means that any theory of how interference comes about must be compatible with all the evidence from the study of completed contact-induced changes, and vice versa. Especially in view of the wild-card mechanism – speakers' deliberate decision to change – my second background assumption is in effect a corollary of this first one.

The second assumption is that there are no absolute linguistic constraints on the kinds and degrees of linguistic interference that can occur. None of the constraints that have been proposed in the literature is valid; it is possible, and usually quite easy, to find counterexamples to all of them (see Thomason and Kaufman 1988: ch. 2 and section 2.7 below for discussion). But if there are no valid constraints, then either each mechanism of interference is in principle unconstrained or different mechanisms have different constraints, such that no particular type of change is ruled out by all of them. It is therefore relevant to note that although various constraints have been proposed, on code-switching in particular, there are in fact no well-established or generally accepted constraints on this or any other mechanism. As with the first background assumption, different probabilities can be established for different kinds of changes, probabilities based both on social factors (e.g., intensity of contact) and on linguistic factors (e.g., markedness). But in this domain everything appears to be possible, although some things are improbable.

2.1 Code-switching

Code-switching, as used in this section, includes both intrasentential switching (sometimes called code mixing) and intersentential switching. I do not mean to suggest by this usage that there are no interesting differences between the two, but at the level of this discussion they appear to be a single mechanism. This is by far the most-studied and most-discussed mechanism of contact-induced language change; indeed, it has sometimes been claimed to be the main or only mechanism (see, e.g., Myers-Scotton 1993: 174). It has attracted an enormous amount of attention, and the body of empirical studies is growing rapidly, ranging from earlier works like Hasselmo (1970), Blom and Gumperz (1972), and Pfaff (1979) to recent studies like Eliasson (1995) and Backus (1996).

Code-switching is a (perhaps the) major route by which loanwords enter a language. It surely plays a role in at least some kinds of structural borrowing as well, although the more dramatic kinds of structural interference are probably likely to result from code alternation instead (see section 2.2 below). Some authors have denied that code-switching can lead to, or become, borrowing, but the possibility seems to be rejected on *a priori* grounds rather than on the

basis of empirical evidence, and some of the most perceptive case studies (e.g., Heath 1989) have provided evidence to the contrary. In particular, the notion of “nonce borrowing” – the occurrence of foreign morphemes in a language just once or a few times, but as borrowings, not as code-switches – seems to serve as a device for dealing with apparent counterexamples to theoretical predictions about what can and can’t be code-switched (e.g., the purported impossibility of code-switches that combine a root from one language with affixes from the other). Eliasson (1995), among others, has presented convincing evidence that at least some elements claimed as nonce borrowings are actually code-switches.

In fact, I believe that is impossible in principle and in practice to draw an absolute boundary between code-switching and borrowing. They are indeed two separate phenomena, but they are linked by a continuum: as in so many other areas of historical linguistics, the dividing line between them is fuzzy, not sharp. A code-switched word or other morpheme becomes a borrowing if it is used more and more frequently – with or without phonological adaptation – until it is a regular part of the recipient language, learned as such by new learners. It seems likely, for instance, that the English pronouns *I* and *you* appeared first in Thai as code-switched elements (a conveniently neutral pronominal usage in place of the elaborate honorific system encoded in native Thai pronouns) and only later as borrowings, as they are characterized by Foley (1986: 210); these borrowed pronouns are additions to the Thai pronominal system, not (at least not yet) replacements. Introduction of these pronouns into Thai through code-switching would parallel Eliasson’s example of English *and* as a code-switched element in Maori – an element that provides speakers with a short cut, since the native Maori coordinating patterns are much more complex than English coordination.

A strong motivation for treating code-switching and borrowing as points on a continuum is that this treatment shows borrowing to be an aspect of ordinary linguistic behavior rather than an improbably exotic phenomenon that is wholly unlike everyday usage. The addition by borrowing of a new word for a new concept, like *bok choy* in English, must begin with a single use and continue with increasing usage by the innovating speaker(s) and by other speakers, and the addition by invention of a new word, like *photocopy*, must follow the same path. Similarly, an internally motivated replacement of one form or construction by another begins with the introduction of a new feature and proceeds by competition between the new and old features; in many replacements through borrowing, a code-switched element would be the innovation, and its spread would proceed in much the same way as with added features. (This is as true for partial replacements, e.g., native *brothers* versus *brethren* and borrowed *animal* versus *deer*, as for total replacements.)

These parallels are hardly surprising, given that all speakers draw on a variety of repertoires, typically characterized as styles, registers, and dialects, in using a single language. If there is no evidence to the contrary – and certainly no convincing evidence has been presented – then it is surely most reasonable

to assume that speakers whose repertoires include more than one language will employ the same strategies in deploying their linguistic resources. Change resulting from code-switching between different languages does, of course, differ from change via diffusion from another register and dialect borrowing; but, as noted at the start of this chapter, the differences are a matter of degree, not of kind.

A final question on this topic: is code-switching a major factor in shift-induced interference? Probably not: lexical items predominate in code-switching, while phonological and syntactic features predominate in shift-induced interference. Of course lexical transfer does occur in L2 acquisition, but it is not the main transfer phenomenon; for instance, Backus (1996) found that Turkish immigrants in Holland do use Turkish words in their Dutch, but not many, and then generally to fill lexical gaps or to give an “ethnic ring” to their Dutch (Ad Backus, pers. comm., 1996). So, although code-switching undoubtedly occurs in contexts in which groups are shifting to a TL, other mechanisms – especially L2 acquisition strategies – are more likely to be responsible for most shift-induced interference.

2.2 Code alternation

It is by no means the case that all bilingual speakers who use both of their languages regularly engage in code-switching. In many cases the two languages are used by the same speaker with different interlocutors, often monolinguals; a typical example is the use of one language at home and another language at work. The structural effects of this type of bilingual usage, called code alternation, have received much less attention than code-switching, perhaps in part because they are much harder to study directly. But they can be profound.

The main kinds of interference that come about through code alternation seem likely to differ from the main kinds of interference that come about through code-switching. Intuitively, the two seem to have different primary effects: anecdotal evidence about borrowing through code alternation focuses on structural rather than lexical interference, whereas lexical borrowing is the most prominent direct result of code-switching. There is too little evidence about code alternation to be confident about this as a systematic difference, but here are two suggestive examples.

The first is from Michela Shigley-Giusti (1993), a native speaker of Italian (and French) who told this story after spending 12 years as a graduate student in the United States, speaking English almost exclusively. She spoke Italian only with occasional visitors and on occasional trips home to Italy. She reported no code-switching; at most it would have been very rare. Her use of the two languages was therefore code alternation: she spoke English always and only with Americans, and Italian only with Italians. To her surprise (and distress), she was complimented during trips to Italy for “speaking Italian decently for an American”: English had influenced her Italian in phonology (e.g., English

intonation patterns, alveolar stops, and aspirated initial voiceless stops), lexical semantics, and perhaps also syntax. The second example is from Ad Backus (pers. comm., 1996), who reports that – at weekly social occasions that include one American friend and two Dutch friends – his code alternation between Dutch and English leads to severe, though temporary, interference in both languages, including problems with lexical access as well as grammatical interference.

These anecdotes, which can easily be multiplied, are significant for two reasons. First, although the type of interference is certainly borrowing in my narrow sense, there is no hint of conscious intent. On the contrary: Shigley-Giusti, for instance, was hardly gratified to be taken for a non-native speaker of her own language. This point is worth emphasizing because of the lingering belief that borrowing is usually a deliberate choice carried out for reasons of prestige. Second, and more importantly for understanding what is happening, the unconscious and involuntary incorporation of foreign structural features into one of a bilingual's languages fits very well with psycholinguists' finding that "bilinguals rarely deactivate the other language totally" (Grosjean and Soares 1986: 146). Moreover, as Ad Backus (pers. comm., 1996) observes, "deactivation of entrenched nonsalient elements of speech (e.g. most syntactic elements) is probably much harder to do." I would add only that phonetic and phonological elements are also likely to be non-salient and entrenched. Lexicon, by contrast, is more likely to be salient, and that may account for its apparent lesser role in interference via code alternation.

Even if it is true that structural interference happens covertly, in the course of partial activation of one language while speaking another, it may of course still be the case that code-switching produces the same kinds of grammatical interference as code alternation. But the interference would then, by hypothesis, be indirect, by way of partial activation of the one language during the production of sentences or parts of sentences in the other, instead of direct incorporation of one language's structural features into the other language as part of code-switched sequences. That is, the division might be as follows: morphemes, both lexical and grammatical, would be introduced directly via code-switching, changing from code-switches to borrowings through increasingly frequent usage by code-switching speakers and then (if not all members of the speech community engage in code-switching) by adoption by other speakers; morphemes, but especially other features, notably phonological and syntactic structures, would be introduced by bilingual speakers who "inadvertently" access bits of one language while speaking another – and features introduced in this way too would become permanent additions or replacements in the recipient language if they became entrenched in the bilinguals' speech and adopted by other speakers as well. This is clearly not a pure dichotomy: some foreign morphemes are surely introduced through code alternation; grammatical morphemes introduced via code-switching might set in motion a series of changes that ultimately produces significant structural

change; and, most obviously, code-switched morphemes will often include foreign phonological and perhaps also morphosyntactic features, which may or may not be replaced by native structure when a code-switched morpheme becomes a borrowing.

In any case, the main purpose of this discussion is to emphasize the fact that code alternation is likely to be as important as code-switching as a mechanism of contact-induced change – and very likely a more important mechanism when the focus is on structural, as opposed to lexical, interference.

2.3 *Passive familiarity*

Sometimes interference features are introduced by speakers whose competence in the source language is strictly passive – that is, a speaker may borrow a feature from a dialect or language that she or he does not speak actively at all. The mechanism presumably involves partial activation of a foreign system, as in changes via code alternation. This activation must occur because of frequent exposure to the features; but of course a speaker whose language changes through this mechanism must at least understand the source language, so it is likely that most such transfers occur between systems that are very similar, often dialects of the same language.

Many of the features transferred by this means are lexical. For instance, many Americans who don't speak African American Vernacular English (AAVE) nevertheless adopt lexical items from it; an example is the use of *cold-blooded* as an intensifier and to mean "exceptionally good."⁵ Structural features may also be transferred through passive familiarity. The fate of sentence-initial *whom* in my own speech is a typical example. My native rule for the use of *who* and *whom* in this position – in all formal situations, both written and spoken – was that of (at least one variant of) Standard English, with *who* used for subjects of clauses and *whom* used for objects: *Who is going?* and *Who did you say was going?*, but *Whom did you see?* and *Whom did you say he saw?* Informally, I used only *who* sentence-initially. But for years I heard people saying sentences like *Whom did you say was going?* in formal contexts, and although the construction struck me as an irritating hypercorrection, I found myself using it occasionally. At this point, in order to avoid hypercorrection, I dropped sentence-initial *whom* entirely in speech. My point, however, is that I had borrowed – certainly unwillingly – a use of *whom* that was foreign to my native dialect, without being able to speak the source dialect itself.

It is likely that passive familiarity is the mechanism by which TL₂ features contribute to the emergence of TL₃ as the language of a community comprising both original TL speakers and members of a group that has shifted to the TL: original TL speakers probably never speak the TL₂ itself, but passive familiarity with the TL₂ leads to the introduction of some of its features into their speech, ultimately producing the TL₃.

2.4 “Negotiation”

This mechanism, which resembles the concept of accommodation that has received much attention in sociolinguistics (and sociology), overlaps with – or, perhaps better, is a component of – at least two other mechanisms, code alternation (section 2.2) and L2 acquisition strategies (section 2.5). Shudder quotes surround the term because deliberate, conscious negotiation is unlikely (though see section 2.7 below); rather, speakers change their speech patterns (language A) to approximate what they believe to be the patterns of another language or dialect (B).

If the speakers who implement the change are fully bilingual, their beliefs about B’s structure will be accurate, and the resulting change will make A more similar to B; this is what has been called *convergence*, a kind of borrowing in the framework used here.⁶ A typical example is reported by Sandalo for Kadiwéu, a Waikurúian language of Brazil (1995: 7). Kadiwéu has six word order patterns, OVS, VOS, SOV, OSV, VSO, and SVO; but when translating sentences from Portuguese, bilingual speakers usually use SVO order, thus making their sentences more similar to Portuguese. (Of course this example does not mean that Kadiwéu has changed, or even that it is changing; examination of untranslated spontaneous discourse would be needed to find out whether permanent change is in progress.)

But if the speakers who implement the change are not fully bilingual, the resulting change may not match the original B pattern at all. This is extremely common in shift-induced interference. A particularly clear example is the stress pattern that emerged in a dialect of Serbo-Croatian spoken in northern former Yugoslavia near the Hungarian border. Local Hungarian speakers, in shifting to Serbo-Croatian, apparently perceived correctly that it lacked fixed initial stress, the Hungarian pattern; but they maintained their L1-based expectation of fixed stress – missing the actual Serbo-Croatian accent pattern, which has free stress (with some restrictions) – and their resulting TL₂ had fixed penultimate stress. Original Serbo-Croatian speakers adopted this feature from TL₂, so the entire dialect, TL₃, now has fixed penultimate stress.

In the most extreme cases of non-bilingual contact situations, namely the new contact situations that give rise to pidgins (or creoles), members of all speaker groups (usually more than two) employ “negotiation” in making guesses about what their interlocutors will understand; the guesses that facilitate comprehension will become part of the emerging contact language (see Thomason and Kaufman 1988: ch. 6 for discussion).

2.5 Strategies of second language acquisition

One major strategy of second language acquisition has just been discussed: as noted above, “negotiation” is an important mechanism – possibly the most

important one – in shift-induced interference, accounting for L2 learners' efforts to make sense of the input they receive from speakers of the TL. But another important strategy also comes into play in some cases of shift-induced interference, perhaps even in most cases of natural (as opposed to classroom) L2 acquisition. This is the carryover of features from the L1 into the TL as a way of filling gaps in the learner's knowledge of the TL, making expression of certain meanings possible when the speaker lacks adequate knowledge of the TL and/or when the TL lacks the particular features. Both lexical and grammatical features may be carried over in this way; the grammatical features may include both actual transferred morphemes and transferred structure without morphemes, but the latter is probably more common. It isn't clear that this is an entirely independent mechanism; it overlaps with the final one, deliberate decision (section 2.7), though it is probably less conscious than the examples given under that heading.

Here's a typical example. During a period in which speakers of Uralic (specifically Finnic) languages were shifting to Russian, Russian was undergoing extensive internally motivated changes in noun inflection. One aspect of this inflectional change was a merging of two noun classes inherited from Proto-Indo-European, the *o*-stems and the *u*-stems, whose original semantic basis (if any) was already completely opaque in PIE. In most case/number combinations the *o*-stem endings replaced the *u*-stem endings – not surprisingly, because the *o*-stem class was by far the larger. In the genitive singular, however, both the *o*-stem ending *-a* and the *u*-stem ending *-u* remained side by side. The reason for the retention of both endings seems to be that shifting Uralic speakers, whose native languages lacked (and lack) noun classes entirely, assigned separate meanings to the two competing genitive singular suffixes, meanings that were already encoded in separate cases in their native language(s). Their usage was then adopted by original Russian speakers (through borrowing; see section 2.3), so that modern Russian, in the genitive singular of this noun class alone, now has a distinction between partitives (marked by *-u*) and general genitives (marked by *-a*). The semantic differentiation is reminiscent of pairs like English *hanged* and *hung*, and in both instances a semantic distinction was introduced to differentiate between competing forms resulting from analogic innovations; but the source of the semantic difference was internal in the English example and external in the Russian one.

2.6 First language acquisition

The role of first language acquisition in language change is a topic that has received much attention in theoretical discussions of internally motivated change, especially since the rise of generative grammar in the 1960s. The results of generative research on L₁ acquisition and language change are still controversial among historical linguists, but it remains a lively research area. By contrast, the question of L₁ acquisition as a potential or actual mechanism of

contact-induced language change has received (virtually?) no attention in the literature – until 1996, when Robin Queen completed a study that provides solid evidence that language change can result directly from the (near-?) simultaneous acquisition of two first languages.

Queen's evidence comes from her analysis of the speech of 31 children in Germany, 15 of them Turkish–German bilinguals and 16 of them German monolinguals. She investigated a specific phrase-final intonation pattern in which German and Turkish differ, and she found that the bilingual children employed both patterns in speaking both of their languages, but in different pragmatic contexts. That is, they learned both patterns, but instead of confining each one to its source language they developed a mixed system in which each pattern had its own function – and they incorporated this system into both their Turkish and their German. Their innovative system is apparently not stigmatized, because (for instance) German-speaking teachers interviewed by Queen did not seem to be aware of it in the children's German.

Queen's results have several interesting implications. First, and most obviously, it is difficult to describe these children's mixed intonational system as the result of interference *per se* if the children, starting from scratch with both languages, never developed separate German and Turkish intonational systems which could then merge (though this is hard to establish definitely; see discussion below). That is, the mechanism of change was the creation of two L1s by children, not the incorporation into an existing system of features from a different one (with reinterpretation of the competing features) – even though the end result, from the viewpoint of either Turkish or German, is partial replacement of one intonational system with another, under the influence of the other language.

Second, her results raise the question of the extent to which L1 acquisition is operative as a general mechanism of contact-induced change – in other words, the extent to which it overlaps with other mechanisms of contact-induced change. Clearly this is an area for future research, but a few preliminary comments can be made now. Both code-switching and code alternation could be relevant to the development of such a pattern during bilingual L1 acquisition: as children achieve facility with their two emerging languages, some switching back and forth may occur, and this could contribute to the fixing of the two patterns with their pragmatic distinction. If this is what happened with the bilinguals in Queen's study, it means that the children first learned both systems and then mixed them, so the developmental pattern would not be primary L1 acquisition but rather something closer to (though not identical with) processes of change in adult speech that result from these two mechanisms.

Another possibility is that the children never learned and used the two separate intonational systems, but instead acquired both to a sufficient degree that they understood their functional identity, and then sorted out the competing features by assigning them different functions. This is similar to the Russian change described in section 2.5, and it is of course also potentially relevant, at least indirectly, to "negotiation." It differs from the Russian example

in that the implementers of the Russian change, by hypothesis, already knew a complete Uralic language; this inference is justified by the comparable behavior of individual L2 learners, but Queen's results show that it may be difficult or impossible to distinguish, in retrospect, between changes effected by adult L2 learners and changes effected by young L1 learners.

Without much more information about the actual developmental process (for instance, information about whether the bilingual children ever used the actual Turkish pattern in speaking Turkish and/or the actual German pattern in speaking German), we can't decide between the two possible routes of development for Queen's results: acquisition of two patterns followed by mixing or partial acquisition of competing patterns with creation of a new mixed system in the first instance. The most I can say is that the outcome resembles the type of change exemplified in section 2.5 more closely than any other type of contact-induced change that I know of, and that this favors the second route.

2.7 *Deliberate decision*

Theories of language change rarely or never allow for the possibility of deliberate change, except in such trivial cases as the conscious adoption of loanwords and even new sounds in words of foreign origin, for example, when an English speaker pronounces the name *Bach* as [bax]. A major reason for including the present section in this chapter is to underline the fact that a sizable body of evidence now attests to the possibility of large-scale changes that, if not all due to actual conscious decision, nevertheless reflect a community's more or less deliberate manipulation of its linguistic resources in order to create something new.

The most dramatic cases involve two-language mixtures created by bilinguals, apparently to serve as a symbol of a new ethnic identity; see section 4 for examples. Less dramatic but still important cases are the various reports, from widely scattered locations, of speaker groups deliberately withholding their "real" language from outsiders, using instead a distorted and simplified foreigner talk version that, in some cases, forms the basis for a trade pidgin (see Thomason and Kaufman 1988: 175–7 for examples). Other cases involve the creation of a secret language, either by phonological distortion (as in Pig Latin, to which parallels can be found in languages used by entire communities – see Thomason 1995 for discussion) or lexical replacement. And in still other cases the motive for making a particular change has to do with emphasizing in-group status, or differentness from other groups; an example is the introduction of the voiceless lateral fricative into Bantu words by speakers of Ma'a (see below), an extension of this non-Bantu phoneme that serves to make their speech less Bantu-like (Mous 1994: 199). More spectacular examples are the changes made in New Guinea communities that have "purposely fostered linguistic diversity because they have seen language as a highly salient mark

of group identity” (Kulick 1990: 1–2). Kulick cites the startling case of a reversal of all anaphoric gender agreements in one language, with the result that masculine elements correspond systematically to feminine elements in neighboring dialects, and vice versa.

My conclusion from these and other similar examples is not that historical linguists should abandon the search for regularities in language change and theoretical explanations for them, but rather that much more caution is needed in predicting what can and especially what cannot happen to the language(s) of a community over time. Speakers’ creativity is certainly not limited to trivial lexical innovations; given the right social circumstances, it can have enormous linguistic consequences. In the domain of contact-induced change, it is the main reason for the claim at the beginning of section 2 that anything goes.

3 Sources of Change in Language Attrition

Attrition – the overall simplification and reduction of a language’s linguistic structures, without concomitant complication elsewhere in the system – occurs only as a prelude to language death, but the reverse is not true: language death is not always preceded by attrition. In some cases, as is well known, language shift occurs so soon after initial contact that there is no time for attrition to occur. More rarely, speakers will maintain their language under great pressure from a dominant group, borrowing so much lexicon and structure that eventually only fragments of the original language survive (especially the basic vocabulary; see Thomason 1995 for discussion of several such cases, notably Ma’a, a language of Tanzania with Bantu grammar and primarily non-Bantu basic vocabulary). In still other cases, like that of Montana Salish (mentioned near the beginning of this chapter), speaker attitudes or other poorly understood social factors seem to block large-scale borrowing; and in some tragic cases the language vanishes abruptly when all its speakers die as a result of massacre, disease, or natural disaster. Regardless of whether or not there is interference from the dominant language, all these linguistic results, including attrition, are the direct result of language contact – except for the last two, since a killer disease need not be of foreign origin and an earthquake has no human agent. All attrition is thus contact-induced change by the definition given near the start of the chapter, though only some of it involves interference.

In the literature on language attrition, two competing views of the sources of the various simplifying changes have been debated. According to one view, characterized by Woolard (1989: 356) as the “loans to loss” model, extensive borrowing leads eventually to language loss; the implication is that attrition is always accompanied by, or perhaps actually comprises, the adoption of lexical and structural features from the dominant language – that is, convergence toward the dominant language.⁷ The most extreme version of the opposing

view is that, as Cook claims (1995: 226), “convergence does not occur in a dying language,” and “the simplification in the speech of semispeakers is internally motivated” (ibid.: 218). Most linguists who have studied attrition processes would probably argue for some intermediate position, that borrowing does occur in dying languages but is not all that goes on; see, for instance, most of the papers in Dorian (1989).

It seems to me that this debate rests on a false dichotomy. The underlying assumption appears to be that a given change must have one and only one source, either borrowing from the dominant language or simplification resulting from forgetting or never properly learning one’s ethnic-group language. Few authors have considered the possibility of multiple causation, and fewer still have investigated it empirically. A systematic study of the sources of the changes must first identify as many changes as possible in a dying language that is undergoing, or has undergone, significant attrition. The next step is to ask, for each change, whether it is best accounted for by borrowing alone, or by simplification alone (governed by such factors as universal markedness), or by a combination of the two. If either borrowing or simplification could be expected to produce the observed effect, then surely the most reasonable conclusion is that both are responsible for it: multiple causation is well known, though relatively rarely discussed, in historical linguistics (e.g., in internal analogic changes), and in general a change is more likely to occur if independent forces are pushing in the same direction.

One recent case study (one of only two that I know of – see Joseph 1983: ch. 7 for the other) in which the issue of multiple causation is addressed systematically is Fenyvesi (1995), an investigation of changes in the Hungarian spoken by first-generation immigrants and second-generation US-born members of an American Hungarian community in McKeesport, Pennsylvania. McKeesport Hungarian is a short generation away from extinction: almost all the speakers are over 60 years old, and the language is now used only rarely in everyday conversation. Fenyvesi identified several dozen changes – phonetic, phonological, morphological, syntactic, and lexical – and classified them according to the three source categories just mentioned.⁸

For first-generation speakers, the immigrants, she found just one change that could be attributed to simplification alone and 13 changes in each of the other two categories, borrowing-only and both borrowing and simplification. Any attrition in these subjects’ speech would be due to forgetting, not to incomplete acquisition; nevertheless, these results seem comparable to those of the second-generation speakers, for whom imperfect learning is a real possibility. For this group Fenyvesi found four simplification-only changes, 20 borrowing-only changes, and 28 changes attributable to both borrowing and simplification.⁹

Here are a few illustrations of changes in the three categories. All these examples are found in second-generation speakers’ speech, and some also occur in the first-generation speakers’ samples. The replacement of one pre-verb by another in pre-verb-verb constructions, though simplificatory (in tending to

reduce the number of pre-verbs), does not make Hungarian more like English; the same is true of the regularization of irregular stems in inflection. But the change from fixed initial Hungarian stress to stress on a non-initial syllable (namely, on the verb) in pre-verb–verb combinations is certainly not a simplification, and is therefore attributable to English influence alone – the pre-verbs are comparable to English prefixes, and prefixes are normally unstressed in English. The same is true of the appearance of such phonetic features as allophonic aspiration of voiceless stops, a retroflex vocoid realization of /r/, and lengthening of short vowels under stress; the last is a potential complication in Hungarian, since it has phonemic vowel length (which is preserved in McKeesport Hungarian). Similarly, the partial replacement of SOV by SVO word order and the replacement of quantifier + singular noun by English-style quantifier + plural noun certainly make the language’s structure more like English, but they don’t obviously simplify it. In the last category, changes attributable both to borrowing and to simplification, we find such changes as the loss of morphophonemic rules of coalescence and voicing assimilation in consonant clusters, partial collapse of the distinction between definite and indefinite conjugations, dramatic increase in the use of Hungarian generic sibling terms for “male sibling” and “female sibling” instead of specific terms for elder and younger siblings, and loss of the semantically redundant pronominal possessive suffixes in the dative possessive construction. All these changes bring the structure of the language closer to English, and all of them arguably simplify the language.

It is of course quite possible that McKeesport Hungarian is an idiosyncratic case for some reason, or (more plausibly) that language attrition in certain types of immigrant languages differs from language attrition under other social circumstances. And it is certainly true, as various authors have noted, that a complete picture of the attrition process would have to take into account the input received by successive generations of learners of the dying language, because that input will surely differ from one generation to the next if the attrition takes place gradually over two or more generations. The point I would like to emphasize here, however, is that the search for sources of change in a process of global attrition must not be narrowly restricted by a belief that there is necessarily an either/or choice between potential contributing factors.

4 Contact-Language Genesis versus Contact-Induced Change

At first glance the genesis of a contact language seems quite distinct from contact-induced language change, especially in the case of contact languages that are created and stabilized in a relatively few years. But the mechanisms through which contact languages arise are essentially the same as those which operate in ordinary contact-induced change – and, as argued in section 2, to

a considerable extent in internally motivated change as well. Contact languages are therefore extreme results of quite ordinary processes. Moreover, the boundaries between contact languages and cases of heavy borrowing or extensive shift-induced interference are fuzzy, though there are many clear cases on both sides. Because there are borderline cases, and because the same mechanisms are common to both, the differences are best characterized as ones of degree, not of kind (see Thomason 1995, 1997d for arguments in support of this position). In this section I will support this conclusion by surveying briefly the processes by which the various types of contact languages arise.

There are, in my view, just three basic types of contact language. The two best-known and most-studied types are pidgins and creoles, which on my analysis followed the same basic route of development.¹⁰ Prototypical pidgins and abrupt creoles (that is, creoles that do not emerge from a stable pidgin stage) are crystallized through “negotiation” from ad hoc efforts to communicate in a new, usually multilingual, contact situation; this mechanism was discussed in section 2.4, where the point was made that the degree of bilingualism is the main difference between the results of this process in pidgin/creole genesis situations and the results in cases of shift to a TL that is more fully available to the learners.

In sharp contrast to pidgins and creoles, bilingual mixed languages are created by bilinguals: the evidence for this assertion lies in the fact that material from both component languages is intact, undistorted by the kinds of processes that operate under conditions of imperfect learning. One type of bilingual mixed language is created, more or less deliberately, as a symbol of a new ethnic identity. A prominent example is Michif, spoken by the Métis of Canada and the northwestern US, which has French noun phrases embedded in a Cree matrix (see Thomason and Kaufman 1988: ch. 9.3; Bakker 1992; Bakker and Papen 1997; for historical and descriptive information). The most likely initial mechanism for the emergence of this language is code-switching (section 2.1) – the split between noun phrases and other material is reported from a number of code-switching contexts. But of course code-switching alone cannot account for its stabilization as the main language of certain Métis communities; to achieve this result at least a quasi-deliberate decision must have been taken (see section 2.7), and the new sociopolitical identity of the Métis people provides a reasonable motive for such a decision. Another example is Media Lengua of Ecuador (Spanish lexicon, Quechua grammar; see Muysken 1981, 1997). In this case code-switching is a possible mechanism, but code alternation (section 2.2) is at least as likely. And here again deliberate decision, at some level of consciousness, is required to account for the outcome – the replacement, by native Quechua speakers, of almost the entire Quechua lexicon by Spanish lexicon, and stabilization of the resulting mixture for use as an in-group language. A third example is Mednyj Aleut, the language of one of the Commander Islands, with Russian finite verb inflection and Russian loanwords in an Aleut matrix (see Thomason and Kaufman, 1988: ch. 9.4; Golovko and Vakhtin 1990;

Sekerina 1994; Thomason 1997a). The major mechanism through which this language arose is likely to have been code alternation: unlike the mix in Michif, the type of mixture in Mednyj Aleut is not typical of code-switching.

The other type of bilingual mixed language arises through borrowing carried to an extreme, with gradual incorporation of lexical and structural features from another language until nothing is left of the original language but lexicon, including most of the basic vocabulary; the mechanisms involved are the same as in ordinary borrowing situations. As noted in section 3, this is one way in which language death occurs gradually, though it is apparently a rare process. In its final stage, as in the case of Ma'a (see Mous 1994), its effects are indistinguishable from those of language attrition, which, as we have seen, involves extensive simplification as well as borrowing. This probably accounts for the fact that the idea of a long-term process of eventually massive borrowing is still controversial (see, e.g., Brenzinger 1987 and Sasse 1992 for a skeptical view and Thomason 1997b for discussion). Ma'a, which still had bits of non-Bantu grammar as late as 1960, now has almost entirely Bantu grammar (fully elaborated, with no simplification or distortion), and even its non-Bantu lexicon is used only as a secondary code: all its non-Bantu lexical items (mainly of Cushitic origin) have Bantu counterparts that are also used regularly by Ma'a speakers (Mous 1994). The mechanisms involved in the creation of Ma'a probably included both code-switching and code alternation, though there is no way to be certain; another longstanding mixture of this same general type, Kormakiti Arabic (a mixture of Arabic and Greek), surely involved code-switching, at least.

Both the abruptly created bilingual mixtures and the gradually developing bilingual mixtures serve as ethnic-group symbols. But while the former are the languages of new groups (a French/Cree mixed-blood group in the case of Michif, for instance), the latter are the languages of groups that have doggedly maintained their ethnic identity in the face of overwhelming cultural pressure from speakers of another language (or, in the case of Ma'a, two other languages, both Bantu).

5 Conclusion: Evidence for Contact as a Source of Language Change

In this chapter I have attempted to give a comprehensive sketch (the emphasis is on "sketch") of the vast topic of language change that occurs as a result of language contact. The survey has included classifications of contact-induced changes from three different perspectives – effects on the receiving system, correlations of linguistic results with one social variable (presence versus absence of imperfect learning), and differing results in different linguistic

subsystems – as well as seven mechanisms through which contact-induced change occurs. Briefer sections touch on the important topic of changes that occur in dying languages and the essential unity in processes of contact-induced change and of contact-language genesis.

In emphasizing mechanisms of change and their differing results under different social circumstances, my goal has been to give an idea of both possibilities and probabilities. I have argued that anything is possible, from a strictly linguistic perspective; assessing the probabilities that any particular (type of) contact-induced change will occur requires careful sifting of both social and linguistic factors. Among the more useful predictors are degree of bilingualism, degree of linguistic integratedness into a system, and typological distance between the source and receiving languages. But the most interesting examples are those which, like the switch of anaphoric gender-agreement patterns in a New Guinea language, highlight the idiosyncratic nature of speakers' creativity. This factor alone guarantees the continuing failure of all attempts to construct a neat hierarchical ordering valid for all types of contact-induced change.

One topic that has hardly been touched on in the preceding sections might be thought to be the intended heart of the matter, given the inclusion of this chapter in a part entitled "Explaining linguistic change": what about predicting when contact will cause change? This topic has been slighted not because it is unimportant, but because, as noted near the beginning of the chapter, no global predictions can be made. Investigations of contact-induced language change do not permit any confident predictions about when such changes will occur, any more than investigations of internally motivated change permit such predictions.

One question to which some useful answers can be given, however, concerns the retrospective identification of contact-induced changes. That is, how can we tell when we should claim language contact as a, or the, source of a particular change? The easy cases are those in which both form and function have been adopted from another language. When Han Chinese conjunctions turn up in the Kadai language Mulam, together with un-Kadai-like Chinese syntactic patterns (Zheng 1988: 174), no one is likely to deny that Han Chinese is the source of both the morphemes and the grammatical change. Even when no source language can be identified, the shape of a loanword will often betray its foreign origin – for instance, it may (like English *asparagus*) be too long for a single native morpheme, or it may violate the phonotactics of native words.

The hard cases are those in which the interference features consist of structure alone, expressed by native rather than transferred morphemes. This often occurs in borrowing, when there is full bilingualism (e.g., in the example of English interference in Italian discussed in section 2.2), but it is especially prevalent in shift-induced interference, when imperfect learning plays a role in the process. In these cases all the evidence for the interference is circumstantial:

a structural feature of language A matches a feature of language B and diverges from functionally corresponding features in sister languages of A. How did A get that feature? Considerations of universal markedness have often been invoked to decide whether the feature was a spontaneous innovation in A or a transfer from B, the premise being that marked features are unlikely to be innovated spontaneously. But unless some marked features arose through internally motivated change sometime in history, no languages would have them, so this argument is inadequate – though suggestive – when applied to any single feature.

The key to a convincing demonstration that the change occurred at least partly because of contact with B is to look beyond this one change and consider all the changes that have occurred in A but not in its sister languages. If this feature turns out to be completely isolated in the system, the only innovation that makes A more like B, then a contact explanation is not promising. But if other innovations in A also match B features, then contact with B is a likely cause of the whole package of changes. This is especially true if some innovations involve actual transferred morphemes, or if there are several added marked features that are independent of each other (that is, universally marked features with no mutual structural links, e.g., because they occur in separate grammatical subsystems). In such cases, even changes toward less marked structure can reasonably be attributed at least in part to B influence, since interference offers a unified explanation for all the changes.

All this of course requires that B be firmly established as the source language. This task is trivially easy when the package of innovations includes actual morphemes transferred from a language that is still spoken in the neighborhood of A (or even elsewhere), or from a now-vanished language that either has well-known sister languages or is well attested itself. In borrowing situations this requirement is usually easier to fulfill than in shift situations, because the source language for extensive structural borrowings tends to be that of a dominant group, while the original language of a shifting group often disappears entirely after the shift (i.e., when it is not maintained in other communities), and it may not have had any close relatives. In addition to identifying a source language B, one must know what its structure was at the time of the proposed interference, and what the recipient language's structure was; otherwise the direction of interference cannot be established. And finally, it must be demonstrated that the innovations in A occurred at the time of contact, rather than (say) hundreds of years after the putative source language vanished as a result of shift.¹¹

The lesson here is that establishing contact as a cause of language change is possible under favorable circumstances but impossible under less favorable conditions. In this respect contact-induced language change is no different from other subfields of historical linguistics: inevitably incomplete information all too often makes it impossible to tell just what occurred at some distant past time, and why.

NOTES

- 1 But not always. See, in particular, Nancy Dorian's important (1993) paper on the difficulty of distinguishing internally from externally motivated change in contact situations.
- 2 See Thomason (1997c) for further discussion and examples of these categories.
- 3 Note that this revision is not needed for van Coetsem's similar distinction, because his definition does not insist on language shift – only on the agentivity of a speaker for whom the recipient language is a non-dominant foreign language. However, van Coetsem's formulation raises other questions; in particular, it relies crucially on the notion of "linguistic dominance," but a speaker could in principle be quite fluent even in a non-dominant language, and in such a case imperfect learning would be unlikely to influence the process of linguistic interference.
- 4 This section is based primarily on Thomason (1997c). There are, however, several important differences in the discussion here that reflect changes in my views, thanks in significant part to insightful comments from Nancy Dorian and Ad Backus, to whom I am most grateful. The other main analytic difference between the schema presented here and the one in Thomason (1997c) results from my learning about Robin Queen's (1996) results shortly before I completed the present analysis.
- 5 This example may or may not be current in general American English, but it occurs regularly in at least one subpopulation – prison inmates at the state penitentiary in Pittsburgh, PA. White inmates do not speak AAVE, and in fact it would be socially unacceptable (and quite possibly actually dangerous) for them to do so; but the general prison slang includes a sizable number of words and phrases that originated in AAVE.
- 6 Convergence has sometimes been claimed as a separate category of contact-induced change, but the mechanisms and results fit well into the ordinary category of borrowing. Convergence is perhaps (not certainly) more likely to be mutual than other borrowing, and it may (though it need not) involve changes in frequency of occurrence of pre-existing patterns in A and/or B rather than the addition of new patterns.
- 7 This is not Woolard's own view. She suggests instead that interference may be an indicator, rather than a cause, of language shift (1989: 357).
- 8 Classifying the changes is not always a straightforward process, of course. In particular, deciding whether or not a change simplifies the language's overall structure is often difficult or impossible. Nevertheless, Fenyvesi's counts are based on a sufficient number of clear cases to permit confidence about the overall pattern in the results.
- 9 Loanwords were not included in the counts; the lexical features that were included concerned lexical semantics and calquing.

- 10 See, for example, Bickerton (1981) for an opposing view about creole genesis. But Bickerton's theory that abrupt creoles are created by children during first language acquisition crucially entails that pidgins and creoles arise through totally different mechanisms; this makes his theory less general than mine, and since my approach accounts for the data as well as his does, it seems to me that mine is preferable. I say "mine," but of course the view that pidgin and abrupt creole genesis are the same basic process is hardly original with me. Equally of course, the assertion that the two approaches are empirically equivalent requires argumentation and evidence. Exploration of these issues is beyond the scope of this chapter, but the literature on pidgins and creoles contains many discussions of Bickerton's theory, including, for instance, a brief exchange between Bickerton and me on this topic in the *Journal of Pidgin and Creole Languages* 7 (1992).
- 11 Various arguments have appeared in the literature to the effect that shift-induced interference, in particular, can be established under certain circumstances even if these requirements are relaxed. One especially interesting proposal is in Johanna Nichols's recent work (e.g., 1994a). Nichols suggests that certain features, for instance a distinction between inclusive and exclusive "we," can be safely attributed to interference from a long-vanished, unattested substratum language because they are so unlikely to emerge spontaneously. Although I would not accept the evidence of a single feature (for reasons given above), a large enough package of innovated, highly marked, and mutually independent features in A might eventually convince even skeptics like me that a substratum explanation is justified when no candidate for B is attested. Unfortunately, given the very common tendency for marked features to be replaced by unmarked features, the likelihood that a long-vanished, unattested substrate language B will leave behind a large enough package of highly marked interference features in A is probably slim.

24 Dialectology and Linguistic Diffusion

WALT WOLFRAM AND
NATALIE SCHILLING-ESTES

Dialect variation brings together language synchrony and diachrony in a unique way. Language change is typically initiated by a group of speakers in a particular locale at a given point in time, spreading from that locus outward in successive stages that reflect an apparent time depth in the spatial dispersion of forms. Thus, there is a time dimension that is implied in the layered boundaries, or *isoglosses*, that represent linguistic diffusion from a known point of origin. Insofar as the synchronic dispersion patterns are reflexes of diachronic change, the examination of synchronic points in a spatial continuum also may open an important observational window into language change in progress.

In its ideal form, the spatial-temporal interaction may be displayed through an appeal to a version of the *wave model*, in which a change originating at a given locale at a particular point in time spreads from that point in successive layers in a way likened to the waves in water that radiate from a central point of contact.¹ As a hypothetical example of the spatial-temporal reflex, let us assume that there are three linguistic innovations, or rule changes, within a language: R1, R2, and R3. We assume further that all three changes originate at the same geographical location, the *focal area* for the language change. Each one starts later temporally than the other, so R1 is the earliest innovation, R2 the next, and R3 the third (figure 24.1).

At *time i*, R1 is present at the location where the change originated but not in outlying areas.² At *time ii*, R1 may have spread to an outlying area while another innovation, R2, may have been initiated in the focal area. At this point, both R1 and R2 are present at the focal site, R1 alone is present in the immediate outlying area, and neither R1 nor R2 may have spread to an area further removed from the focal area. At *time iii*, the first change, R1, may have spread to the more distant area, but not the later changes, R2 and R3. In this hypothetical pattern of diffusion, we see that the successive dialect areas marked by isoglosses – that is, lines delimiting the boundaries of each of these rules – in geographical space reflect successive stages of language change over time.

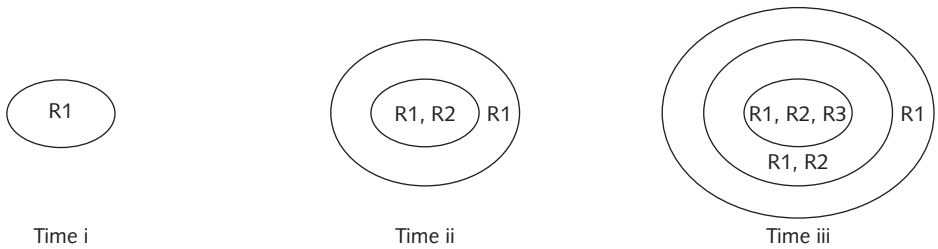

Figure 24.1 The wave model of linguistic diffusion

The model represented in figure 24.1 is conceptually appealing, but it is also simplistic and it often ends up begging essential descriptive and explanatory questions about the empirically documented facts of dialect diffusion. What are the social and linguistic mechanisms whereby forms spread, and what is the transitional phase like? What kinds of diffusional configurations result from the process? And, given that it has been maintained that the dialect boundaries represented by isoglosses are “a convenient fiction existing in an abstract moment in time” (Carver 1987: 13; and see our discussion of this point below), what might an empirically motivated, dynamic model of diffusion look like? To a large extent, our discussion will concern itself with establishing the kinds of conditions and qualifications that need to be set on an ideal, abstract model of diffusion in order to connect it with the empirical facts of dialect distribution and to delimit the documentable patterns of diffusion. Our focus is thus on the *transition* and *embedding* questions with respect to language change rather than the *actuation* question, which addresses why language changes take place to begin with (Weinreich et al. 1968).³

Although dialect diffusion is usually associated with linguistic innovations among populations in geographical space, a horizontal dimension, it is essential to recognize that diffusion may take place on the vertical axis of social space as well. In fact, in most cases of diffusion, the vertical and horizontal dimensions operate in tandem. Within a stratified population a change will typically be initiated in a particular social class and spread to other classes in the population from that point, even as the change spreads in geographical space. For example, Labov’s research (Labov 1966, 1972a; Labov et al. 1972) indicates that much change in American English is initiated in the working class and lower middle class and spreads from that point to other classes.

We focus on the diffusion of dialect forms per se, but there is a fundamental sense in which the transmission of linguistic innovation is framed by the broader question of the diffusion of innovations. For example, Rogers (1983) argues that there are at least five factors that influence the diffusion of customs, ideas, and practices: (i) the phenomenon itself; (ii) communications networks; (iii) distance; (iv) time; and (v) social structure. While linguistic structures present a unique type of “phenomenon” for the examination of diffusion, the other factors influencing diffusion, such as communications networks, distance, and social

structure, are hardly unique to the dispersion of linguistic innovations. In fact, our ensuing discussion should confirm the essential role of all of these factors in linguistic diffusion, just as they figure prominently in other types of diffusion.

The framing of linguistic diffusion within a more general model of diffusion however, should not be taken to mean that the social or “external” factors that affect linguistic structure do so in ways that simply parallel their influence with respect to other cultural phenomena. We maintain that there is a sense in which the role of social factors in language change is fashioned to accommodate the structure of language vis-à-vis other cultural phenomena. For example, the current sociolinguistic position on the origin of change “universally points to the working class and lower middle class as the originators of sound change in contemporary American English” (Kroch 1978). This locus for the initiation of change is quite different from that observed for other cultural phenomena. With respect to technical advances, we know that middle-class groups, not working-class groups, are the primary innovators of change so that primary social diffusion comes from the top (Rogers 1983). For linguistic phenomena, innovations initiated by the elite tend to be limited to borrowings from external prestige groups (Guy 1988); members of higher social classes do not introduce changes from within the language. The current sociolinguistic position on the locus of change also differs from the traditional position within linguistics (cf. Bloomfield 1933: 476; Joos 1952; Fisher 1958) that the lower classes strive to emulate changes initiated by the upper classes in language as they do in other cultural phenomena.

Furthermore, given the “natural” linguistic basis of many changes originating in the vernacular speech of the working classes, it is convenient for a dominant group to mark itself as linguistically distinct from the underclass by resisting or inhibiting the changes toward “more natural” processes proffered by vernacular dialect speakers. In such a model, natural linguistic changes spread from the lower classes to the higher social classes when they are ratified and evaluated as socially acceptable. The examination of linguistic dispersion through a population may thus inform a more general model of diffusion about the interaction of the innovative “phenomenon” and the social and demographic factors that enable the process of diffusion.

1 Orderly Variation and Diffusion

All change necessarily involves variation.⁴ Speakers do not suddenly adopt a new form as a categorical replacement for an older form, whether the form involves a gradual, imperceptible change in the phonetic value of a vowel within a continuum of phonetic space or an abrupt, readily perceptible change involving the metathesis of consonants or the linear realignment of constituents within a syntactic phrase. Instead, there is a period of variation and coexistence between new and old forms in the process of change. This transitional

Table 24.1 Variation model of change

Stage of change		E ₁	E ₂
1	Categorical status, before undergoing change	X	X
2	Early stage begins variably in restricted environment	X/Y	X
3	Change in full progress, greater use of new form in E ₁ where change first initiated	X/Y	X/Y
4	Change progresses toward completion with movement toward categoricity first in E ₁ where change initiated	Y	X/Y
5	Completed change, new variant	Y	Y

period of fluctuation has often been ignored in historical linguistics under the assumption that language change cannot be directly observed. Further, variation in language has traditionally been dismissed as unsystematic and irrelevant, a reflection of linguistic performance rather than competence and, hence, of no bearing on models of language change or diffusion. However, as Weinreich et al. put it: “The key to a rational conception of language change – indeed, of language itself – is the possibility of describing orderly differentiation in a language serving a community . . . in a language serving a community, it is the absence of structured heterogeneity that would be dysfunctional” (1968: 101).

An empirically based model of the dynamic process of diffusion must recognize a variable transition period in the spread of dialect forms. However, this transitional period is not one of chaotic, random fluctuation; instead, it is a stage of systematic variability, or “ordered heterogeneity” that guides language change meaningfully toward completion. Following Bailey (1973), we hypothesize that there are a number of stages that change goes through in the transition from the categorical use of one variant to its categorical replacement by another. In between these two points are variable stages that show systematic constraints sensitive to internal linguistic and external social factors. Furthermore, the systematic variability of fluctuating forms will correlate synchronic relations of “more” and “less” to diachronic relations of “earlier” or “later” stages of the change. This is perhaps best shown by setting up a simple, ideal model of the stages of change, as we do in table 24.1. Table 24.1 shows the change from the categorical use of one form, X, to another, Y, in two different linguistic environments, E₁ and E₂. Fluctuation between the forms is indicated by X/Y.

Although the variable stages of change do not always follow the ideal model for a number of reasons (cf. Bailey 1973; Fasold 1990; Wolfram and

Schilling-Estes 1996), there is ample documentation in the quantitative sociolinguistic literature (Labov 1980a, 1994) to affirm the general applicability of this model of change to a broadly based set of language situations.

The notion of linguistic “environment” in such a model may be defined in terms of a structural context, such as a syllable position in the case of phonological change or a phrasal configuration in a syntactic one, or it may be defined in terms of lexical sets. In other words, the model itself is impartial to the Neogrammarian–lexical diffusion controversy that has underscored the ongoing development of theories of phonological change over the last couple of decades (see Labov 1981, 1994; Kiparsky 1988, 1995b (reprinted in this volume); Hale, this volume). Furthermore, it should also be understood that the notion of variability in this model applies to both intra-speaker and inter-speaker variation. In other words, an individual speaker will go through a period of fluctuation between the old and new variant, and speakers within a given speech community will show variation from speaker to speaker with respect to the use of the new and old variant.

To illustrate, consider the case of *h* in English words such as *hit* [hIt] for *it* [It] and *hain't* [hent] for *ain't* [ent].⁵ There is ample documentation (Pyles and Algeo 1982; Jones 1989) that *h* was present in these words in earlier forms of English and that it is still found to some extent in isolated regions of the United States such as Appalachia, the Ozarks, and some Eastern coastal islands (Wolfram and Christian 1976; Wolfram et al. 1997). At one point, *h* was found invariantly in these items in both phrasally stressed syllables (e.g., *Hit's the one I like*) and unstressed syllables (e.g., *I like hit*).⁶ The occurrence of the *h* in these items then began to fluctuate (sometimes *h* occurred and sometimes not in the production of a given speaker) in unstressed syllables while it was still maintained invariantly in stressed syllables. Next, the *h* was variably deleted in both unstressed and stressed syllables, but it was more frequently deleted in unstressed syllables, where the change first started. Through time, the *h* was completely lost in unstressed syllables while it was variably deleted in stressed syllables. And finally, *h* was lost in both stressed and unstressed syllables categorically. The stages of this change are summarized in table 24.2, using *h* to indicate the categorical presence of *h*, *h/∅* to indicate its variable presence, and *∅* to indicate categorical absence.

Among American English dialects today, stages 3 and 4 are still represented in various isolated rural vernacular varieties and stage 5 is current mainstream standard English usage, where the loss of *h* in *it* is complete.⁷ As found in this example, the dialect differences in the use of initial *h* indicated among different sets of speakers represent an ongoing change at different stages in its progression. Although table 24.2 presents a simplified picture, given other social and linguistic complexities involved in the distribution of this trait, it serves as a model of the progressive steps that typically characterize the orderly dispersion of a dialect form, as well as a model of a language change still in progress in some dialect areas.

The lectal–temporal relation of tables 24.1 and 24.2 is necessarily based upon the *apparent time assumption*, which has become a basic analytical construct

Table 24.2 Stages of change in the loss of *h* in (*h*)*it* and (*h*)*ain't* in American English

Stage of change		Unstressed syllables	Stressed syllables
1	Earliest stage of English, before undergoing change	<i>h</i>	<i>h</i>
2	Earlier stage of English, at start of <i>h</i> loss	<i>h/∅</i>	<i>h</i>
3	Change in full progress, <i>h</i> still exhibited by some older speakers in isolated dialect areas	<i>h/∅</i>	<i>h/∅</i>
4	Change progressing toward completion, <i>h</i> exhibited in restricted environment by some speakers in isolated dialect areas	\emptyset	<i>h/∅</i>
5	Completed change, includes most English dialects outside of isolated regions	\emptyset	\emptyset

within sociolinguistics over the past three decades (Labov 1963, 1994; Chambers 1995; Bailey et al. 1991). The fundamental assumption of the apparent time construct is that, other things being equal (e.g., social class, dialect contact, etc.), differences among generations of adults will mirror actual diachronic developments in language (Bailey et al. 1991). From this perspective, the speech of each generation is assumed to reflect the language as it existed at the time when that generation learned the language. While the apparent time construct has been applied almost exclusively to inter-generational differences within the same speech-community, it seems appropriate to extend this construct to the analysis of the geographical dispersion of language change as well (Bailey et al. 1993). For example, we assume that *h*-dropping in *hit* and *hain't* represented in table 24.2 spread from the urban, focal areas of change in the United States into outlying rural areas in successive stages. The change is complete in these urban areas and therefore can no longer be observed "in progress." At the same time, the change can still be observed in progress in some more rural areas, as successive generations of speakers exhibit stages 3, 4, and 5.⁸

It is typically assumed in quantitative sociolinguistics that an increase or decrease in the incidence of a particular linguistic variant in apparent time indicates an expansion or recession of a change, respectively. Thus, we assume in table 24.2 that the decreased use of the initial *h* in *it* and *ain't* by younger speakers in a given community is indicative of a change toward the loss of the initial *h*. While this assumption matches the empirical facts in this instance, it is not always the case that inter-generational differences reflect unilateral

diachronic change. The most obvious exception to the apparent time assumption is the phenomenon of *age-grading*, where the use of a form is associated with a particular stage in the life cycle of a speaker. For example, teenagers may use a particularized set of lexical items that are associated with this stage of life; however, these items will be abandoned later in adult life because they are no longer age-appropriate. Meanwhile, the next generation will proceed through a similar cycle.

There are more subtle exceptions to the apparent time assumption, namely reversals and pseudo-reversals of change in progress. These cases require more elaborate cross-sectional analysis to determine and explain the pattern of change. One of the best-known instances of a seeming reversal of a change in progress is that presented by Labov (1963) in his analysis of the raising of the nuclei of /ay/ and /aw/ in Martha's Vineyard, an island located off the coast of Massachusetts that has been a noted vacation spot for generations. Labov demonstrated that on this island, while older residents showed a movement toward the lowering of the traditionally raised nuclei of /ay/ and /aw/, middle-aged speakers reversed this trend. This reversal is maintained to a somewhat lesser extent by younger speakers, most likely as a way of asserting their islander identity against mainlanders who flock to the island in ever-increasing numbers.

We have found a pattern of raising and backing for the nucleus of the /ay/ vowel on the Outer Banks island of Ocracoke, located off the coast of North Carolina, which suggests, at first glance, that the recession of raised /ay/ is being reversed in a way parallel to that reported by Labov (1963) for raised /ay/ and /aw/ in Martha's Vineyard (Wolfram and Schilling-Estes 1996). Ocracoke Island, settled in the early 1700s, is located about 20 miles from mainland North Carolina and, to this day, is not accessible by road. Thus, Ocracokers were isolated not only geographically but socially for about two and a half centuries. Shortly after World War II, the longstanding isolation of Ocracoke Island came to an end, and a vibrant tourist industry transformed the island. Historically, the Outer Banks region was characterized by a distinct production of /ay/ which was close to the phonetic value [ɔy] – a production which has led to their characterization as “hoi toiders,” for *high tiders*. In Ocracoke, as in Martha's Vineyard, there are select groups of middle-aged speakers with more /ay/-raising than older speakers. This patterning suggests a reversal of a change in progress that parallels the Martha's Vineyard case, especially when coupled with the fact that the lowering of the nucleus of /ay/ to a low central vowel is a process which affected most varieties of English at some point in history. However, when we compare the youngest group of speakers with both the middle-aged and oldest generations of speakers we find a dramatic decrease of [ɔy] for the young speakers compared with the two older age groups. Thus, the overall pattern of change across the three generations does not show a reversal of a change in progress but a temporary revitalization of the traditional variant before the complete erosion of [ɔy]. The “pseudo-reversal” we observe in Ocracoke is, then, quite different from the reversal of change reported for Martha's Vineyard.

The orderly transition of linguistic forms not only shows systematic relationships between the relative use of variants in terms of earlier and later stages of spreading forms. Change also tends to show a characteristic trajectory slope in the relative *rate of progression* through its transitional stage. Most variationists (Weinreich et al. 1968; Bailey 1973; Labov 1994) maintain that there is a prototypical rate of change which applies to the dispersion of new forms. This pattern appears to apply both to the adoption of new forms on an individual level (Bailey 1973) and to the spread of forms within a new community (Weinreich et al. 1968). Change tends to start out at a slow rate, progressing rapidly in mid-course, and then slowing down again in the last stages, modeling the trajectory of an S-shaped curve. The change slope applies to change on an intra-speaker and inter-speaker level; it also applies to change taking place along a vertical or horizontal plane. As Bailey et al. note:

Like diffusion through the social spectrum, spatial diffusion takes place in a three-part temporal process that simulates an S curve, with a period of infancy, of slow expansion, during which the trait is relatively uncommon; a middle period of rapid expansion after a critical threshold has been reached; and a later period of saturation and filling in as potential adopters become scarce. (1993: 366)

Such a model has implications for several different dimensions of the diffusion process, including the observation of diffusion in progress. For example, the relatively rapid rate of progression through the mid-course of change makes this period of change less accessible to direct observation than change at its endpoints. The window for observing change in progress will be open longer at the endpoints of the change trajectory – when the older or newer form is clearly predominant – than at a midpoint of change when the fluctuation between forms is likely to be most balanced between the use of the new and old variant.

There are also implications about the orderly progression of change and the role of the lexicon in change that seem related to the progression slope. For example, the role of the lexicon in phonological change is more prominent at the incipient and cessation stages of a change than at its midpoint. Furthermore, we expect relationships of “more” and “less” in the relative use of variants to be more directly correlated with “earlier” and “later” stages of the change during the more rapid and maximally generalizable expansion period for new forms than at the endpoints of the change. In fact, we submit that part of the resolution of the ongoing controversy over regularity in phonological change may be related to the trajectory slope of the change.⁹ From this perspective, irregularity and lexical diffusion are maximized at the beginning and the end of the slope and phonological regularity is maximized during the rapid expansion in the application of the rule change during the mid-course of change. Our study of the recession of the traditional production of /ay/ as [ɔy] in Ocracoke and the incipient diffusion of unglided [a:] from the Southern mainland bears this out (Wolfram and Schilling-Estes forthcoming). The adoption of the Southern

mainland unglided variant in Ocracoke is, at this point, still quite provisional, being used in less than 10 percent of the cases where it might be used for /ay/. And at this stage, it appears to be lexically constrained in its use and still somewhat resistant to use in the most productive phonological environment for ungliding indicated in the mainland South, namely, preceding a voiced segment (Bernstein and Gregory 1994). We thus see that the progression slope of change may be related to fundamental questions pertaining to the dynamic process of change and diffusion.

2 Traditional Models of Linguistic Diffusion

In our quest for a model of linguistic diffusion that fits the empirical reality of change uncovered by sociolinguists and variationists, it is instructive to review some traditional models for the spread of language change which have been proposed within the course of dialectological and sociolinguistic study. The traditional *tree model* used to illustrate the evolution of languages has long been recognized by historical linguists and other language scholars as inadequate for the description of diffusion (e.g., Hock 1991). This model presupposes that closely related language varieties may suddenly sever all contact with one another, diverging from that point into separate languages. Linguistic innovations occurring in one of these language varieties after such a split thus will be confined to that variety alone; the other varieties will be left unaffected, even if they are found in the same geographic vicinity as the innovating language. Of course, such a tree model is a highly idealized representation of a far messier linguistic reality, since language varieties in close proximity, even those genetically dissimilar, often influence one another in profound ways.

To provide a conceptual picture for the area/rather than strictly genetic spread of linguistic innovations, Schmidt (1872) developed the *wave model* discussed above. To recapitulate briefly, the wave model holds that a given linguistic innovation radiates outward from a central or focal area, in which the change is usually carried through to completion. From there, the change proceeds to a *transitional area*, in which the change occurs in varying degrees of completion, depending on the distance from the focal point of change. That is, a change which reaches an area adjacent to the focal area may occur in almost all environments for the change, while one which is some distance removed from this focal area may be effected in only one or two highly favored environments. We have already seen how the loss of word-initial *h* in the pronoun *hit* in American English spread in this manner from urban focal points. At an early stage in the process of this change, the focal points for the change would have been the locus for total or near-total loss of *h* in *hit*; surrounding these urbanized focal areas would have been transitional zones in which the loss of *h* was incomplete in varying degrees. For example, in an area near the

focal area, we may have found complete loss of *h* in unstressed position and variable loss in stressed contexts; while in a transitional area farther removed from the focal point, we might have found that *h* loss occurred only variably, and then only in the most highly favored environment – unstressed position.

It seems, then, that we could characterize the transitional area of traditional wave-model-based approaches to linguistic diffusion, not as one dialect area, but as a number of subtly different dialect areas. Trudgill (1983) refers to these varieties as MIXED LECTS – that is, dialectal varieties in which an innovative variant alternates with a conservative variant. Trudgill (1983) also maintains that there are so-called FUDGED LECTS – dialectal varieties in which the competition between a new and an older form is resolved in favor of a compromise form, perhaps a phonetic compromise, in the case of a sound change. For example, Chambers and Trudgill (1980) note that in the transitional area between the pronunciation of /u/ as [U] in the North of England and the innovative [ʌ] pronunciation that occurs in Southern England, we find both types of intermediate language variety – mixed lects in which /u/ is pronounced as [U] in some words and as [ʌ] in others, and fudged lects, in which /u/ takes on the phonetically intermediate value [y]. From the perspective of systematic variation we discussed earlier, however, a fudged lect seems to be something of an anomaly, since speakers in an area on which an innovation is encroaching typically show alternation between two variants – an older form and the new form – rather than the sudden innovation of a third, compromise variant. A “compromise” vowel is perhaps best viewed not as a resolution between two competing vowels, but as a vowel which is currently located, as it proceeds through a natural rotational pattern (e.g., Labov 1994), at an intermediate point in phonetic space between a traditional vowel value and an innovative pronunciation. For example, Trudgill’s “compromise” form [y] is most likely a synchronic reflex of the diachronic progression of [u] to [ʌ], as part of a vowel subsystem movement involving the lowering and unrounding of high back vowels.¹⁰

Of course, as we have observed above, the very isoglosses we draw to divide lectal areas from one another are, at least to some extent, “a convenient fiction.” That is, dialect areas, particularly the subtly different areas which comprise the transitional area for a linguistic change, cannot necessarily be said to have clear-cut boundaries. The isogloss of one particular innovation almost certainly will not correspond to that of another innovation, even if each innovation radiates from the same focal point at the same point in time. And even if we consider only one particular change when drawing our lectal boundaries, the fact that innovative forms exist side by side with relic forms throughout the transition area, in higher or lower proportion to the relic forms, greatly hinders our efforts. For example, if in a given transitional area, a new variant is used 80 percent of the time in one locale, 75 percent of the time in another locale, and 70 percent of the time in a third region, are we to classify each small area as its own lectal area, or should we perhaps draw a dividing

line at, say, 75 percent usage of the new form? Girard and Larmouth (1993) suggest that a transitional lect is perhaps best modeled not as a set of features which either belong or do not belong to the lect in question but as a version of a *fuzzy set*. In Girard and Larmouth's interpretation, membership in the set is characterized as a percentage figure rather than by a simple binary distinction – that is, +/- Lect A. For example, suppose we wanted to describe a particular lect, Lect A, as a fuzzy set composed of certain dialect features, including loss of *h* in *hit*. If *h* loss in *hit* is variable in this dialect, we would not simply say that initial *h* in *hit* is not a member of Lect A – that is, that the value of *h*'s membership in Lect A = 0. Rather, we would express *h*'s membership in the set of features comprising Lect A as a number between 0 and 1, say 0.75, for example. Of course, exactly how such a figure might be determined is a complex issue indeed and is beyond the scope of the present discussion. The reader is referred to Girard and Larmouth (1993) for more discussion of this point.¹¹

Beyond the transitional area of a linguistic change we find what are traditionally labeled *relic areas* – that is, areas which the innovation fails to reach. Most often such areas are geographically distant from focal areas. Sometimes, however, physical barriers to communication, such as mountainous terrain or a body of water, may block the spread of a change from a relatively nearby focal point. Social and demographic factors such as social and racial isolation among neighboring groups may similarly play a significant role in delegating areas to relic status. Thus, African American working-class groups in Northern metropolitan areas within the United States may maintain some older Southern rural dialect forms (e.g., the production of *ask* as *aks* or the use of completive *done*, as in *Kim done took out the trash*) despite the fact that they are one or two generations removed from their Southern roots. Patterns of racial and social segregation have, in fact, greatly inhibited significant changes such as the Northern Cities Vowel Shift (Labov 1991, 1994) from affecting inner-city black communities, who remain immune to such changes while maintaining a Southern-based vernacular dialect.

Areas which have been designated as relic areas with respect to one linguistic innovation may very well be innovative, focal areas when another language change is brought into focus (e.g., Hock 1991); thus, the designation of certain areas as focal, transitional, or relic is largely relative, though demographic and social factors such as population density may be favorable to the heavy concentration of linguistic innovations in one particular area, such as a large, centralized metropolitan area.

3 The Gravity Model

A number of studies conducted by dialectologists and sociolinguists over the past several decades indicate that the wave model is not empirically justified,

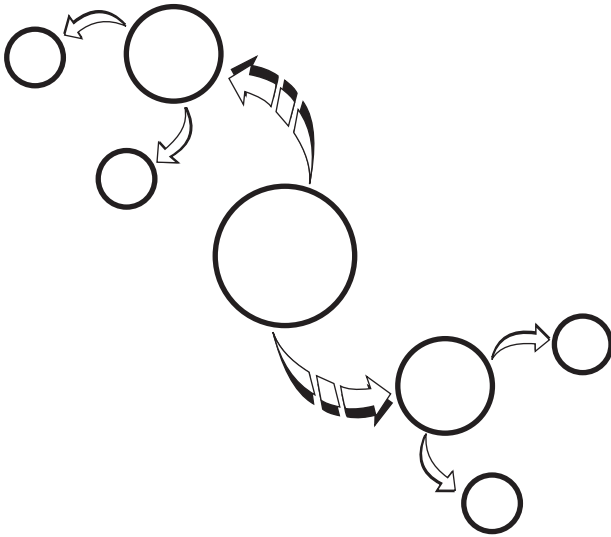

Figure 24.2 The gravity model of linguistic diffusion

even if it is expanded to incorporate systematic variability per our earlier discussion. Trudgill (1974) demonstrated that a slightly different model, termed the *gravity model* or the *hierarchical model*, provides a much better fit for the observed data on dialect diffusion. According to this model, which is borrowed from the physical sciences, the diffusion of innovations is a function not only of the distance from one point to another, as with the wave model, but of the population density of areas which stand to be affected by a nearby change. Changes are most likely to begin in large, heavily populated cities which have historically been cultural centers. From there, they radiate outward, but not in a simple wave pattern. Rather, innovations first reach moderately sized cities, which fall under the area of influence of some large, focal city, leaving nearby sparsely populated areas unaffected. Gradually, innovations filter down from more populous areas to those of lesser population, affecting rural areas last, even if such areas are quite close to the original focal area of the change. The spread of change thus can be likened not so much to the effects of dropping a stone into a pond, as with the wave model, but, as Chambers (1993: 150) puts it, to skipping a stone across a pond. Figure 24.2 illustrates such a model. Note that larger circle sizes indicate increased population density.

The reason linguistic and other innovations often spread in a hierarchical pattern is attributed to the fact that greater interpersonal contact is maintained among places with larger populations, and heavy contact strongly promotes the diffusion of innovations. This latter point was formulated by Bloomfield in 1933 as the *principle of local density*. However, even as the amount of interaction between two areas is directly proportional to the population density of these areas, so it varies inversely with the distance between the two locales – that is,

interaction diminishes as the distance between two population centers increases. This interplay between the population density of two areas and the distance which separates them thus parallels the effects of density and distance on gravitational pull (that is, the amount of influence two physical bodies exert upon one another), according to the physical scientific gravity model.¹²

As early as the 1950s, geographers, most notably Hägerstrand (1952), used the gravity model to describe and predict the diffusion of cultural innovations such as technical advances. Trudgill (1974) adapted Hägerstrand's model to his sociolinguistic study of the Brunlanes peninsula of Norway to show that the spread of a certain phonetic change – that is, the change in the phonetic value of the /æ/ phoneme from [ɛ] to [a] – was diffusing throughout the peninsula according to the pattern predicted by the gravity model rather than the wave model. The change to [a] began in a central area of relatively dense population and proceeded from there to lesser centers of population and from there to more rural, less populous areas. Further, Trudgill (1974) showed similar patterns in the diffusion of linguistic innovations in the East Anglia area of England. For example, he demonstrated that a generalized phonological process of initial *h*-dropping currently underway in England (not the lexically restricted, almost completed version we discussed earlier) spread from London directly to Norwich, the population center of East Anglia, without affecting the thinly populated area between the two cities. If the wave model accurately represented the diffusion of linguistic innovation, the intervening area should have been more *h*-less than Norwich, rather than almost completely *h*-ful, as it is in reality.

A number of other studies reveal similar patterning whereby linguistic innovations “skip” from one population center to another, leaving rural areas unaffected until the final stages of the change. For example, Callary (1975) showed that [æ] diphthongization in words like *tag* and *bad* and [a] fronting in words like *lock* and *pop* spread from Chicago to downstate Illinois in a hierarchical pattern; and Bailey et al. (1993) demonstrated a hierarchical pattern as well for the diffusion of the /ɔ/-/a/ merger in word pairs like *hawk/hock* throughout Oklahoma. Even before the gravity model was applied to the study of linguistic diffusion, the hierarchical spread of change was documented; for example, Kloeke's (1927) study of the change from [ū] to [ü] in medieval Dutch and Flemish reveals a hierarchical rather than wavelike spread for this change, while Kurath (1949) noted the importance of cities in the diffusion of linguistic innovations along the east coast of the United States.

In most cases of hierarchical diffusion, the spread of innovation is from relatively large regional centers to smaller, more localized towns and other gathering-places. Occasionally, a change may reach a smaller city before a slightly larger area, perhaps for geographic reasons, such as difficult terrain, or for social and demographic reasons, such as a high concentration of a certain social class in a given city. When changes actually do proceed strictly from larger cities to smaller, we have so-called *cascade diffusion*. Such patterning has been observed, for example, in the spread of musical influence from London

in the 1960s throughout the world, first via other of the world's major cities and then gradually downward to small towns and rural areas (Haggett 1979).

Another type of diffusion that is recognized within the gravity model is *contagious diffusion*. This refers to changes which actually do spread in wavelike patterns – that is, changes whose spread is a primary function of distance only, rather than population as well. Bailey et al. (1993) demonstrate such diffusion in their investigation of the spread of a lax vowel [ɪ] rather than tense vowel nucleus [i] in the word *field* in Oklahoma speech. Interestingly, this contagious diffusion co-occurs with the hierarchical diffusion observed for other innovations in Oklahoma speech, as well as with yet a third pattern of diffusion, *contra-hierarchical diffusion*, discussed below.

4 Limitations of the Gravity Model

Although the gravity model accounts reasonably well for the diffusion of many linguistic innovations, it falls short in a number of respects. As Trudgill (1983) and Chambers (1993) point out, empirical evidence indicates the need for the inclusion of factors other than distance and population into this model. For example, the gravity model cannot account for the effects of terrestrial barriers on the diffusion of innovation. And because the model was originally applied to non-linguistic innovation, it cannot account for the unique effects of a linguistic system itself on the spread of changes to that system. For example, the gravity model cannot account for the effect of structural similarity in regional language varieties with respect to the accommodation of new forms into a region. Trudgill (1983) maintains that a dialect will more easily adopt an innovation from a dialect to which it is highly similar than from a less similar dialect. That is, “it appears to be psychologically and linguistically easiest to adopt linguistic features from those dialects or accents that most closely resemble one’s own, largely, we can assume, because the adjustments that have to be made are smaller” (ibid.: 74). Trudgill attempts to correct for this inadequacy in the gravity model by factoring into it a structural similarity effect. That is, he describes the level of interaction between two centers not only as directly proportional to the population density of each center and inversely proportional to the distance intervening between them, but also as directly proportional to how similar the two dialects are to one another.¹³

While Trudgill’s modification represents an important attempt to improve the sometimes simplistic gravity model, it too has its limitations. As we have discussed above, studies of variation within language and how this variation leads to change indicate that the acceptance of a change depends on a number of linguistic and social factors – not just mere similarity between dialects. For example, in our study of the diffusion of external innovations into Ocracoke English (e.g., Wolfram et al. 1997; Wolfram and Schilling-Estes 1996), we have found that mere “similarity” does little to explain why certain innovations are

adopted and others seemingly rejected. As Ocracokers lose their distinctive [ɔy] vowel, they may adopt one of two main innovating pronunciations: unglided [a:], which is typical of mainland Southern speech, or the non-Southern variant [a^l], with a low central nucleus. We mentioned above that Ocracokers are somewhat resistant to adopting Southern [a:], particularly before voiced obstruents, the very environment where /ay/ is most likely to unglide in mainland Southern speech. Yet in many respects, the Ocracoke dialect can be said to be more “similar” to mainland Southern varieties than to non-Southern dialects, particularly in its vowel system which, like the Southern vowel system (e.g., Labov 1994), is characterized by the raising and tensing of the [I] and [ɛ] vowels (as in the pronunciation of *fish* as [fiš]) as well as by the general fronting of back vowels. Despite this similarity, there is quite a bit of resistance in Ocracoke to the encroachment of the Southern [a:] variant vis-à-vis non-Southern [a^l]. Part of this resistance appears to be phonetic in nature: because /ay/ most readily unglides to [a:] when its nucleus is a low central vowel [a], Ocracoke [ɔy] displays a degree of phonetic immunity to ungliding (Labov 1994). Further resistance to adopting the [a:] innovation stems from a complex array of social factors, most notably the social meaning islanders attach to the various /ay/ pronunciations they now come into contact with on a daily basis. We return to this point below, in our discussion of contra-hierarchical diffusion.

5 Amplifiers and Barriers to Diffusion

As noted earlier, broad-based models of diffusion (Rogers 1983) encompass at least five overarching factors that affect the spread of linguistic innovations: the phenomenon itself, communication networks, distance, time, and social structure. The gravity model takes into account the factors of distance and communication networks (at least on a macro-level, as a function of population density), while Trudgill’s model attempts to factor in a dimension related to the diffusing phenomenon itself. Sociolinguistically grounded approaches to language change tend to rely heavily on the role of social structures in the diffusion of innovations.

Bailey et al. (1993) point out that just as topographical features may act as barriers to the spread of innovation (or as amplifiers which encourage diffusion, as in the case of a well-placed, easily navigable river), the social and demographic characteristics of a region serve as even stronger barriers to and amplifiers of change. Changes do not spread evenly across all segments of a population, since some demographic groups are simply more resistant to or accepting of change in general, or to certain specific changes, than others. We have already mentioned that Labov’s research (e.g., Labov 1966; Labov et al. 1972) indicates that members of “upwardly mobile” social classes, such as the upper working class and lower middle class, as defined in traditional

socioeconomic terms, are more quick to adopt innovations than members of other classes. A number of other studies replicate these results (these are summarized succinctly in Chambers 1995: ch. 2); and further studies show that females are also among the leaders in linguistic change (see Chambers 1995: ch. 3 for a summary of a number of these studies). Further, younger speakers are generally quicker to adopt new speech forms than older members of a given speech-community.¹⁴ Thus it is instructive, in tracking the spread of a change, to investigate the usage of a form not only across different regions, but across different age groups and socioeconomic classes, as well as both genders. For example, in their study of the spread of a number of linguistic innovations across the state of Oklahoma, Bailey et al. (1993) demonstrate that one can obtain a clear picture of the temporal spread of language changes by examining the use of innovative forms in different age groups as well as in communities of differing population densities.

Social factors other than age, gender, and social class also act as amplifiers for and barriers to the diffusion of linguistic change, although their role is not always as clear cut as is that of the above three factors. For example, the presence of an ethnic minority population in an area may serve as an amplifier for one particular change but yet act as a barrier in another area or with respect to another change. Bailey et al. (1993) note that African American ethnicity serves as an amplifier to *r*-lessness in Texas speech, while it acts as a barrier to the spread of unglided /ay/ preceding voiceless consonants (e.g., *right*, *like*). Barriers may further be classed as more or less permeable depending on how strongly they block the spread of a change.

In addition, any thorough investigation of the effect of social factors on the diffusion of linguistic innovations needs to include a closer look at communication networks than that provided by the gravity model, which simply holds that, in general, denser populations communicate more with one another than do residents of sparsely populated areas. We find such a focus on micro-level communication networks in the work of Lesley Milroy (e.g., Milroy 1980, 1987) and James Milroy (e.g., Milroy 1992), who have done a number of studies on the effects of the social networks of individual informants and small groups of speakers on the diffusion of linguistic innovations (Milroy and Milroy 1985; J. Milroy 1992; also see McMahon 1994a: 248–52 for an excellent summary of the Milroys' work on diffusion-related issues). The results of the Milroys' social network studies show that, in general, a population whose social networks are dense and multiplex – that is, whose social networks involve frequent, prolonged contact with only a small peer group, in a number of social contexts – are more resistant to linguistic innovations than are populations whose social ties are looser – that is, whose communications are spread out among many people of different social groups and are, hence, briefer and less frequent with each individual communicant.

Under the *social network model* for the spread of linguistic innovations, the first people to adopt changes are those with loose ties to many social groups but strong ties to none, since strong ties inhibit the spread of change. In order

for the changes adopted by these people, called *innovators*, to make their way into more close-knit groups, they need to be picked up by so-called *early adaptors* – people who are central figures in tightly knit groups but who are risky enough to adopt change anyway, perhaps for reasons of prestige (whether overt or covert). Because these early adaptors are well regarded in their social groups, the changes they adopt are likely to be picked up by other members of these groups, thereby diffusing through a large segment of a population.

Given that urban populations are generally considered to be bound by looser ties than rural societies, one can easily see how the Milroys' model for linguistic diffusion parallels the gravity model; both models maintain that innovations begin in urban populations. The chief difference in the two models is that, under the gravity model, increased interaction of any type leads to increased diffusion of innovations; the Milroys maintain, however, that the interaction must be of a certain type in order for innovation to spread. Further, the Milroys' model affirms Labov's conclusions that "upwardly mobile" social classes are the quickest to spread innovations, for it is the individuals who make up these classes who are most likely to maintain loose social ties with a number of people from outside their immediate peer groups, as they strive to move out of their current social class. Similarly, it is not surprising under this model that women often lead linguistic change, since, in close-knit communities, it is usually women who hold jobs that bring them into contact with members of social groups other than their own (e.g., Chambers 1995: ch. 3).

Thus, the social network model may be seen not so much as a further description of how linguistic innovations diffuse through a given population, but rather as a potential explanation for the diffusional patterns that dialectologists and sociolinguists have already observed.

6 Contra-Hierarchical Diffusion

The final type of linguistic diffusion we examine points out just how strongly social factors may affect the spread of language change. In their study of the social and demographic factors that influence the diffusion of change in Oklahoma speech, Bailey et al. (1993) discovered that, while one important change, the spread of the /ɔ/-/a/ merger, appeared to be diffusing according to the hierarchical model, the spread of the quasi-modal *fixin' to* (as in *They're fixin' to go now*) displayed exactly the opposite diffusional pattern. That is, *fixin' to* initially was most heavily concentrated in the rural areas of the state and spread from there through increasingly large population centers until it reached the state's most urban areas. The different patterns of diffusion for these two linguistic changes are given in figures 24.3 and 24.4, taken from Bailey et al. (1993). In each illustration, figure (a) gives the spatial distribution of the form for respondents born in or before 1945 and figure (b) gives the spatial distribution for respondents born after 1945 in order to show the spread of the change in

a Respondents born in or before 1945

Image Not Available

b Respondents born in or after 1946

Image Not Available

Figure 24.3 Spatial distribution of /a/ in *hawk*
Source: Bailey et al. (1993: 369)

a Respondents born in or before 1945

Image Not Available

b Respondents born in or after 1946

Image Not Available

Figure 24.4 Spatial distribution of *fixin' to*
Source: Bailey et al. (1993: 372–3)

apparent time. Note that the circles on the maps represent cities, with larger cities being represented as larger circles. Figure 24.3 illustrates how the /ɔ/-/a/ merger, spread, in general, from more populous areas in Oklahoma to more rural areas from the pre-World War II years to the present day. Figure 24.4 shows that *fixin' to* spread in the opposite way, proceeding from rural areas to larger cities over the course of the past several decades.

Given that communication, and hence the spread of innovations, is generally held to increase with increased population density, how can we explain the *contra-hierarchical diffusion* displayed by *fixin' to*? Bailey et al. (1993) note that there is an important difference in the social setting that contextualizes the /ɔ/-/a/ merger and that which contextualizes *fixin' to*. While the identical pronunciation of word pairs such as *hawk/hock* or *Dawn/Don* is generally held by Oklahoma residents to be a mark of increasing urbanization or sophistication and reaches its highest concentration in the speech of recent transplants to Southern states such as Oklahoma, *fixin' to* is regarded as a traditional, rural form and is most prominent in the speech of Oklahoma residents whose Southern heritage is well established. While many older Southern forms have indeed faded in the face of newer Northern forms as more and more non-Southerners migrate to the South, a number of rural forms have flourished, spreading from outlying areas to population centers as long-time Southerners seek to assert their identity against newcomers from the North. Bailey et al. maintain that *fixin' to* is one such form, as evidenced not only by the diffusional patterns observed for this item but also by the strong correlation they found between informants who use the form and nativity within Oklahoma, as well as positive valuation of the state as a good place to live. Brown (1991) has also reported a contra-hierarchical spread for the merger of /I/ and /ε/ before nasals (that is, the *pin-pen* merger) in Tennessee.

In our study of Ocracoke English (e.g., Wolfram et al. 1997; Wolfram and Schilling-Estes 1996), we have observed that the traditional pronunciation of the /ay/ diphthong as [ɔy] in Ocracoke serves as a marker of island identity, much as does raised /ay/ in Martha's Vineyard (Labov 1963). While [ɔy] is not diffusing beyond the confines of the island (or beyond the Outer Banks island chain), its value as a marker of in-group identity does allow it to serve as a barrier which blocks the incursion of non-Southern [a¹] and especially mainland Southern [a:] into Ocracoke speech. In other words, [ɔy] is not spreading contra-hierarchically as are some other traditional, rural forms of speech in the American South, but it is not simply being supplanted by forms which are moving down from major population centers, thanks in large part to its social meaning in the Ocracoke community.

We have seen, then, that the social valuation accorded to linguistic forms can drastically affect the process of linguistic diffusion. Linguistic markers of local identity may serve as barriers to urban forms diffusing down into rural areas; or these markers may be of such importance over a widespread region that they actually take root and spread, effectively reversing the usual direction of linguistic diffusion.

Explaining the empirical facts of dialect diffusion obviously calls for a multidimensional approach that considers an array of geographical, social, and linguistic factors which may interact in different ways. Furthermore, a dynamic model of diffusion must encompass the systematic variability that characterizes language change. While such a perspective exposes the inadequacies of many of the traditional models for describing and explaining dialect diffusion and some of the proposed alternatives, in the long run, a model which remains continually sensitive to the emerging empirical facts about dialect diffusion is the only one that will ultimately serve dialectologists and linguists, whether their concentration is variation study or another area of specialization. In the final analysis, our goal is to understand why and how language changes over time and space.

ACKNOWLEDGMENT

Our research on Ocracoke English is supported by the National Science Foundation Grant No. SBR-93-19577.

NOTES

- 1 Although the wave model of language change goes back to the nineteenth century (Schmidt 1872), a revised model which incorporates structured intra-language variability into the model is used here. For the most part, this model follows Bailey (1973).
- 2 Weinreich et al. (1968) and Labov (1994: 311) maintain that there is no precise distinction to be made between the origin of language change and diffusion, since it is not the act of innovation that changes language, but the act of influence that instantiates it. Thus, "the change and the first diffusion of the change occur at the same time" (Labov 1994: 311).
- 3 This is not meant to minimize the significance of the actuation question, which must ultimately be considered in an authentic account geared toward explanation.
- 4 Whereas all change necessarily implies a period of variation, the converse is not necessarily true. That is, not all variation implies change. Some variation may be very stable and a product of the natural performance of language rather than an indication of dynamic directionality with respect to the replacement of forms.
- 5 We are much more certain about the earlier, widespread presence of initial *h* in *hit* (Jones 1989: 245ff) than we are about the *h* in *ain't*. The different sources which apparently merged in the development of *ain't*, including *haven't*, *aren't*, and *amn't* (Cheshire 1982), and the socially charged status of this item over time have clouded the picture of change somewhat. It is possible that the *h* in *ain't* was originally found

- only in those items derived from *haven't* and that this *h*-initial form was subsequently generalized to encompass tokens of *ain't* derived from *amn't* and *aren't*.
- 6 The differential distribution of *h* loss in stressed and unstressed syllables is still manifested in *h*-initial pronouns in present English. Note, for example the difference between *Him, I like* versus *I like 'im*.
- 7 Other varieties of English (Trudgill 1990: 42), as well as other Indo-European languages, have a much more extensive version of *h*-dropping that is strictly phonologically conditioned. In a sense, the lexically restricted version illustrated here vis-à-vis the generally applicable phonological deletion process found in other varieties of English (Jones 1989: 245ff) realistically illustrates a case of the "regularity controversy" with respect to dialect patterning (Labov 1994).
- 8 We appeal to the *uniformitarian principle* in assuming that the patterning of current changes in progress reflects the way in which completed changes were effected. This principle, as stated by Christy (1983: ix), is that "knowledge of processes that operated in the past can be inferred by observing ongoing processes in the present." See now the discussion in Janda (2001: section 8) and in the introduction to this volume.
- 9 The behavior of forms through the course of the change slope is not unlike the behavior of forms as they proceed through the stages of early and second language acquisition. In language acquisition, a period of rote learning of forms paves the way for the application of an exceptionless rule, which is then
- realigned to accommodate the empirical reality of regularity and irregularity within language.
- 10 Our perspective here assumes that vowel changes follow orderly rotational schemes as set forth in Labov (1994). The three main principles guiding vowel rotation are as follows:
- Principle I: In chain shifts, tense nuclei rise along a peripheral track.
- Principle II: In chain shifts, lax nuclei fall along a non-peripheral track.
- Principle III: Tense vowels move to the front along peripheral paths, and lax vowels move to the back along non-peripheral paths.
- In this schema, Trudgill's fudged lects would simply be a stage of principle II (Labov 1994: 176).
- 11 Bailey's (1973) framework is also reminiscent of the fuzzy set model for defining dialects, particularly in transitional areas. Bailey maintains that speakers of a language are inherently polylectal – that is, each of them possesses internal grammars for a number of different lects, which Bailey sets up on a scalar, implicational array. In this schema, the existence of certain features will imply others, and different lects are simply subsets of the overall set of implicational relations.
- 12 Even the mathematical formula initially used to express the cultural influence of two population centers on one another is reminiscent of physical scientific models for gravitational effects. This formula is as follows: $M_{ij} = P_i P_j / (d_{ij})^2$, where M = interaction, P = population, and D = distance (e.g., Trudgill 1983: 74). Trudgill (1974) first applied this formula to the spread of linguistic

innovations specifically, as opposed to cultural innovations in general; but, as we shall see, he expressed serious reservations about its adequacy as an accurate model of linguistic influence.

- 13 In formulaic notation, the revised model looks like this:
 $M_{ij} = s \cdot (P_i P_j / (d_{ij})^2)$, where s is a

variable expressing linguistic similarity.

- 14 In fact, it is this sharp contrast in younger versus older speakers' adaptability to linguistic innovation that allows sociolinguists to make the *apparent time assumption*, discussed at length above, on which so much of their work is based.

25 Psycholinguistic Perspectives on Language Change

JEAN AITCHISON

Historical linguists aim to explain language change, ultimately in terms of properties of the human mind. A massive amount of work on causes of change, therefore, could be regarded as “psycholinguistic,” or in broader, more fashionable terminology, “cognitive.” In practice, a limited number of topics have been highlighted as belonging to this domain, even though dividing lines between psycholinguistic/cognitive and other fields of enquiry are fairly difficult to draw: “In no way can a pragmatic account be usefully separated from a cognitive one” (Payne 1992: 3) is a typical comment.

Psycholinguistic/cognitive discussions of change are essentially about “top layer” causation. In historical linguistics, at least three overlapping layers of causes can usefully be distinguished. First is immediate trigger, which can be regarded as “sociolinguistic,” as when, in Labov’s seminal paper, the permanent inhabitants of Martha’s Vineyard imitated the vowels of the fishermen they subconsciously admired (Labov 1963). Second is “linguistic proper,” due to vocal tract configurations, or to the maintenance of language patterns, as when, in the Martha’s Vineyard case, the diphthongs [ai] and [au] follow a roughly parallel course of change. The third level is when broad properties of the human mind are hypothesized to account for any such changes. For example, memory limitations or processing procedures might plausibly be invoked to explain why front and back vowels tend to move in tandem not just in Martha’s Vineyard, but everywhere. This “top layer” of causation can be labeled psycholinguistic or cognitive, even though such labels need to be used with care: they have been applied in the literature in a number of different ways. In this chapter, psycholinguistic and cognitive are used in the fairly broad sense of “relating to language and mind in a way which underlies or goes beyond strictly linguistic explanations.” This territory is a no-person’s-land between language universals and more general psychological ones. The location of the boundary is often dependent on the theory adopted, rather than on an (unachievable) Olympian view of the situation.

Within this fuzzy language and mind area, two broad topics have been repeatedly linked to questions of language change: one is child language acquisition, the other is speech processing. This chapter will outline some of the basic controversies, and assess the state of play.

1 Child Language

Each child has to create language afresh for itself. This mundane truism has given rise to a recurring belief that change occurs between generations. It was popular at the end of the nineteenth century: "The chief cause of sound changes lies in the transmission of sounds to new individuals," stated Hermann Paul (1880: 63), for example. This view still recurred in the twentieth century: "The ultimate source of . . . linguistic change . . . is the process of language acquisition" (Andersen 1978: 21); "A basic cause of change is the way children acquire the language . . . The child's grammar is never exactly like that of the adult community" (Fromkin and Rodman 1993: 348).

The belief in adult-child language discontinuity is therefore a longstanding one. However, the mechanism which is presumed to underlie this generation gap varies with the decades. Imperfect learning by infants was a favored mechanism in the nineteenth century: "If languages were learnt perfectly by the children of each generation, then languages would not change," asserted Henry Sweet (Sweet, 1899: 74).

In the 1960s, children's natural language learning ability was opposed to adult limitations. The years 2-14 were held to constitute a "critical period" for language acquisition, and its "termination was related to a loss of adaptability and inability for reorganization in the brain" (Lenneberg 1967: 179). Halle (1962) was possibly the first explicitly to link this presumed critical period with language change, when he proposed that only children can carry out major linguistic alterations, which "optimize" their grammars:

due to deterioration or loss in the adult of the ability to construct optimal (simplest) grammars on the basis of a restricted corpus of examples . . . I conjecture that changes in later life are restricted to the addition of a few rules in the grammar and the elimination of rules and hence a wholesale restructuring of his grammar is beyond the capabilities of the average adult. (*ibid.*: 74).

Halle's ideas were taken up particularly by those working within the transformational-generativist paradigm: "Simplification typically occurs in the learning of speech by children" (Kiparsky 1968: 195); "A child rarely, if ever, constructs a grammar more complex than that of his models" (King 1969: 74).

Those continuing this tradition now argue that parameter setting by children (the selection and fixing of pre-set options) is the cause of major changes: "If

one aims to understand language change partly in terms of the way languages are acquired by young children, obsolescence must be treated as a by-product of some new parameter setting" (Lightfoot 1991: x).

However, this view begs a number of questions. Most radically, is there any evidence that language change truly occurs between generations? The question turns out to be oversimple: children's language acquisition alters in character across the years, with youngsters tuned in to different aspects of language at different ages. They are also subjected to changing social pressures. So at the very least, the question needs to be examined in agebands (Kerswill 1996).

Children are highly sensitive to phonetics/phonology in their first few years. Typically, youngsters pick up female-dominated sound changes, judging from work on Philadelphia English: children aged 3 and 4 "are receptive to the dialect influence of their caregivers at a time when the caregivers are most likely to be female and locally based" (Roberts 1997: 264), with the result that "it is the female-dominated sound changes that are advanced in early language learning" (ibid.: 264) – though males and older children may also play a role (Kerswill 1996). The generation gap is not readily apparent early in life, therefore. Children match their speech to those around (Roberts and Labov 1995). At the most, children who pick up on a phonetic change in progress may well advance it further as they get older. Child overgeneralizations (such as *foots* for 'feet') fade away, and non-standard forms found in child language are mostly unlike those found in language change. So imperfect learning by youngsters is possibly a mirage (Vihman 1980; Bybee and Slobin 1982; Labov 1989a; Aitchison 1981).

Schoolchildren aged 6–12 gradually move away from parental influence, and become progressively affected by their contemporaries: "At the preadolescent stage, we find the beginnings of a move from parent-oriented to peer-oriented networks" (Kerswill 1996: 196). The notion that children might have "optimal grammars" is unsubstantiated. More probably, children, like adults, set up alternative analyses, which may or may not get eventually decided upon (Hankamer 1977; Guy and Boyd 1990) – though an eventual decision might have longer-term consequences, in that it could be regarded as a trigger for parameter setting, or, in more traditional terms, the starting point of a reanalysis with (eventually) far-reaching consequences.

No child language event happens sufficiently fast or thoroughly for a parameter to be set or reset in one swoop, however one identifies the various parameters. In the short term, changes tend to be small-scale and "local" (in the sense of Joseph 1992) within both child language and historical linguistics. The notion of parameter setting may therefore be useful primarily as a metaphor encapsulating the long-term need for pattern tidying and pattern maintenance.

A generation gap develops mainly when children identify strongly with peer groups, which commonly happens in adolescence (e.g., Bailey and Maynor 1988; Cheshire 1982; Eckert 1988; Romaine 1984). No absolute "critical period" cut-off point is found for language acquisition. Instead, a gradual decline occurs (Newport 1991) – though this does not include the lexicon, which is expanded throughout a person's life. In their teenage years, children's vocabulary escalates,

and often diverges from that of their parents. In English, a leap in vocabulary size around the age of 14 is associated with the acquisition of rules for word derivation (Aitchison 2000). Teenagers also nurture their "own" lexical items, which tend to accelerate language change. New coinages acquire regular endings by default, as with *blagged* 'conned, exaggerated' (Ayto 1990); so do extended uses of existing words, as with *shooted up* 'injected' (of drugs). This hastens the loss (in English) of irregular past tenses and plurals, especially as children may rarely hear old forms such as *gelt*, once the past tense of *geld*.

This does not happen only in England. In Papua New Guinea, Tok Pisin is a pidgin/creole whose lexicon is based heavily on English, and whose syntax is a mix of English and local languages. First-generation Tok Pisin creole speakers (those who have acquired pidgin Tok Pisin as a first language) show a marked divergence from their pidgin-speaking parents. Consider their treatment of plurals (Aitchison 1990). Teenage speakers have inherited a Tok Pisin plural prefix *ol*, as with *ol man na ol meri* 'men and women,' versus singular *man na meri* 'a man and a woman.' Many also speak English, and have imported English plural *-s* for use with words which are either borrowed from English, or in which there is a strong similarity between the Tok Pisin and English lexical items. This happens above all in three areas: loanwords for food, as *sandwiches*, *drinks*, *tsips* 'chips'; words for periods of time, as *minits*, *auas* 'hours', *wiks*, *wikends*, *afteununs*; and words for people, as *frens* 'friends,' *bratas* 'brothers,' *sistas*. But this is not just an English take-over, because in numerous cases both plurals are used, as *ol sandwiches*, *ol frens*. Any plural tends to be preceded by either *ol* or a numeral, as *tri wiks*, whether or not an English *-s* is attached. How the situation will be resolved in the long run is unclear, though double marking in these three vocabulary areas is creeping into others, as with *ol stons* 'stones.' These teenagers are therefore making use of a new type of plural, one not found in the speech of their older relatives.

To summarize, babies do not initiate changes. Groups of interacting speakers do, particularly adolescents. Any permanent change happens largely via the vocabulary. Change also happens when casual styles of speech become accepted in more formal settings. Occasional accounts of communities which showed a leap between generations are possibly due to a failure to record the full range of stylistic alternatives: the gap between old and young in Fox (an American Indian language), for example, turned out to be due to a preference for formal styles among the old, and informal among the young, though both styles were available to each group (Goddard 1989).

But why have so many intelligent linguists been prepared to adopt the "babies rule" viewpoint? Are they simply attempting to make language history "fit into . . . the hottest Designer Models" (Lass 1997: xiii)? Traditions within the subject are largely to blame, it turns out: false models of change were instilled into generations of linguists. A "tadpole-to-frog" model (my term) was widespread until the 1960s: a linguistic tadpole was assumed to gradually "turn into" a later frog. How this happened was a puzzle to many, and a "change-between-generations" model was readily adopted.

Sociolinguists, and particularly William Labov, have now solved the “tadpole-to-frog” problem, by proposing a “young-cuckoo” model of change (my term): a new form arises in competition with the old, then increases in use, and finally, like a young cuckoo, pushes the older form out of the nest. A number of historical linguists have subsequently adopted and popularized such a competition model (e.g., Kroch 1989a). A “multiple-births” model (my term) is gradually replacing the young-cuckoo one (Aitchison 1995): often, multiple variants exist in different parts of a community, or in different styles. They fluctuate for a time, maybe even for generations. Gradually, one variant wins out over the others.

In the case of children and change, then, close-grained sociolinguistic studies have shown that some proposed psycholinguistic explanations are a mirage. But this does not imply that all psycholinguistic/cognitive explanations are irrelevant, as will be discussed below.

2 Speech Processing

Speech processing mechanisms are likely to cause change, it has been argued, though in practice speech comprehension has been invoked more often than speech production.

Two basic problems underlie discussions of this issue. The first is the long time lag between any supposed processing need and its final psycholinguistic effect. A second problem (as noted earlier) is how to draw the line between psychological explanations and other types (linguistic, pragmatic, typological, etc.). For example, verb–object closeness is statistically the norm (Tomlin 1986). Is the historical insertion of an object for a finite verb which lacks one (e.g., Joseph 1980b) a linguistic explanation or a psycholinguistic one? We could either say “finite verbs need objects” (linguistic) or “the human mind perceives certain actions as being performed on something” (pragmatic/psychological). Unfortunately, linguists themselves vary as to whether they label such an explanation psycholinguistic or not.

The following account therefore takes into consideration only those papers where the authors have themselves claimed a psycholinguistic explanation for change. It omits topics such as “transparency” (e.g., Lightfoot 1979), since this falls into linguistic (level two) explanations of pattern maintenance. This account also leaves out non-historically oriented cognitive discussions of discourse (e.g., Givón 1990, who talks about “the cognitive basis of discourse coherence”) and linguistic availability (e.g., Keenan and Comrie’s 1977 “accessibility hierarchy”). It also passes over the multiple publications relating to cognition and language origin (see Aitchison 1996 for a summary), and this inevitably also leaves aside the copious recent literature on grammaticalization (e.g., Hopper and Traugott 1993; Fischer 1997; Heine and Bybee, both this volume).

Most of the work in this (now narrowly defined) area has assumed that comprehension (parsing) needs have affected linguistic structure. These claims have varied from decade to decade, and will be dealt with below in roughly chronological order.

An imbalance between the needs of memory and those of perception might cause change, according to an early influential paper (Bever and Langendoen 1972). The loss of English noun inflections between the eleventh and fifteenth centuries was due to the complexity of these inflections, which put too great a strain on the memory, Bever and Langendoen argued. But after the loss of inflections, it became perceptually difficult to split sentences up into main and subordinate clauses when a relative clause was involved, because the relative pronoun did not have to be included, as in:

- (1) *Lete fetche the best hors maye be founde* (Mallory, fifteenth century)

This processing difficulty, they argue, led to the relative pronoun becoming obligatory in sentences of this type.

Bever et al. (1977) also argued that processing mechanisms can cause the acceptance of strictly ungrammatical sentences, as:

- (2) One of my elephant's birthdays is today (my example)

This is technically ungrammatical, and should be:

- (3) One of my elephant's birthday is today

which most people regard as odd. Bever and his colleagues were therefore among the earliest authors to argue for processing explanations of language change.

A problem with this whole field is the one-off nature of various interesting speculations. For example, Menn and MacWhinney (1984) pointed out that many languages avoid repeated morphs, and proposed a processing (perceptual) explanation. For example, *un-* cannot be attached to a word already beginning with that prefix, so **an un-unhappy man* becomes *a not unhappy man* (Aitchison and Bailey 1979).

An important set of explanations in the 1970s and 1980s related to word order and word order change. Kuno (1974) was an early paper which argued that relative clauses preceded nouns in OV languages, but followed them in VO ones in order to avoid center-embedding, which is perceptually difficult to process. The paper was, however, more psycholinguistic than historical, in that it did not specify how changes toward this configuration might come about. Nor did it explain why the majority of the world's languages, including many OV ones, have postnominal relative clauses, a matter taken up by Antinucci et al. (1979). This claimed that prenominal relatives cause perceptual problems: matrix and subordinate clauses cannot be reliably distinguished, and so they tend to be avoided.

But John Hawkins was perhaps the first to try seriously to link psychological/typological findings with language change, in a series of books and papers stretching across decades (e.g., Hawkins 1979, 1983, 1988a, 1988b, 1994). Most notably, he put forward a principle of cross-category harmony, which coincidentally tied in with X-bar theory. This principle asserted that “there is a quantifiable preference for the ratio of preposed to postposed operators within one phrasal category . . . to generalise to others” (1983: 134). He realized the historical difficulty involved in this: if languages are striving toward cross-category harmony, why do they then not achieve their goal? Why do some become inconsistent and change their word order? He therefore attempted to specify mechanisms by which any changes come about. In this explanation, he realized the importance of doublets (e.g., *John’s the hat, the hat of John*) which alter their relative frequencies, and proposed outline constraints for handling this (still not adequately solved) problem.

Hawkins’s later work has less to say about how any changes are implemented. He has pointed out, for example, that the languages of the world overall prefer suffixes to prefixes, whatever their word order type (Hawkins and Cutler 1988; Hawkins and Gilligan 1988), for which he provides a processing explanation – a clarity principle, though he has little to say about the historical mechanisms by which this principle is implemented. In short, he has moved from proposing mechanisms for change to more general claims about why languages are the shape they are, which he relates to processing needs. In his more recent work, he argues for “Early Immediate Constituents” (1994): the human parser, he suggests, prefers orders in which any comprehender can quickly establish the immediate constituents for any given phrase. This accounts for a wide range of well-known phenomena, such as heavy NP shift. The parser will dislike:

- (4) I gave [the huge octopus that was extremely difficult to catch] to Aloysius
(my example)

and will prefer:

- (5) I gave to Aloysius [the huge octopus that was extremely difficult to catch]

– though other explanations are possible. Wasow (1997) points out that “endweight,” the tendency to place long complex phrases at the end of sentences, is typically attributed to parsing needs. But the demands of planning must also be taken into consideration, he argues, and might be paramount.

A general tendency, therefore, seen both in Hawkins’s performance theory of order and constituency (1994) and in linguistic theory in general, is the search for broad-ranging principles which contribute to an understanding of linguistic ability. However, it would be helpful for those interested in historical linguistics if the working of such principles could be tied in more directly to specific changes, especially as most changes start out as “local” ones which only later generalize to a wider set of data (Joseph 1992).

An important aspect of Hawkins's work for historical linguists is that he has always attempted to quantify his data. Increasingly, linguists are realizing that sociolinguistic variation is not the only sort of data which needs to be quantified: all constraints are potentially violable, and quantification is needed in this area also. Optimality Theory proposes that each language has its own ranking of these constraints (Archangeli and Langendoen 1997), and, usefully, work within this framework has started to appear on historical topics, mostly so far on phonology (Nagy and Reynolds 1997; Zubritskaya 1997; introduction to this volume, n. 135). Perhaps when historical linguists have reliable, quantified typological data on preferred constructions, they can hypothesize the parsing/production principles which favor these. Equally importantly, they may be able to specify how languages alter their constructions in order to fit in with such requirements, and also explain why they sometimes appear to resist doing so.

Within psycholinguistics, a further massive amount of effort is being put into work on connectionism (parallel distributed processing). Promising areas are how children acquire past tenses, and how humans identify words (e.g., Kim et al. 1994; Elman 1993). But so far, only occasional link-ups have been made with language change (e.g., Tabor 1993), even though the notion of changing connection strengths has potential implications for this field. However, an interesting recent speculation is that optimality theory and connectionism might prove to be compatible (unpublished paper by Mark Liberman, quoted in Nagy and Reynolds 1997).

But perhaps the most promising area of language and mind is the rapidly increasing literature on why languages are the shape they are, and which constructions are liable to change into which others. This work ties in with broader considerations, such as the origin of language, which is still felt by many historical linguists to lie outside their field, even though both historical linguistics and language origin studies share central topics such as grammaticalization. The overall unification of all these burgeoning strands is a hope for the future.

Bibliography

BIBLIOGRAPHIC ABBREVIATIONS

BLS <i>n</i>	Berkeley Linguistics Society, Proceedings of the <i>n</i> th Annual Meeting. Berkeley: Berkeley Linguistics Society
CILT <i>n</i>	Amsterdam Studies in the Theory and History of Linguistic Science. Series IV, Current Issues in Linguistic Theory, <i>n</i>
CLS <i>n</i>	Chicago Linguistic Society [Papers from the [General Session (= no. 1)] / [Parasession on <i>x</i> (= no. 2)] at the <i>n</i> th Annual Meeting]. Chicago: Chicago Linguistic Society
CLASNET	Cross-Language Aphasia Study Network (Centre de recherche, Centre hospitalier Côte-des-Neiges, Montréal)
CSL <i>n</i>	Cambridge Studies in Linguistics, <i>n</i>
CSLI	Center for the Study of Language and Information (Stanford University)
ICHL <i>n</i>	Papers/Proceedings from the <i>n</i> th International Conference on Historical Linguistics
NELS <i>n</i>	Proceedings of the <i>n</i> th Meeting of the North East Linguistics Society
NWAVE	New Ways of Analyzing Variation (in English) [annual conference]
TIL <i>n</i>	Trends in Linguistics, Studies and Monographs, <i>n</i>
TSL <i>n</i>	Typological Studies in Linguistics, <i>n</i>
WCCFL <i>n</i>	Proceedings of the West Coast Conference on Formal Linguistics, <i>n</i>

Aarsleff, Hans (1974). The tradition of Condillac: the problem of the origin of language in the 18th century and the debate in the Berlin Academy before Herder. In Hymes 1974b (pp. 93–156). [Repr. in Aarsleff 1982, pp. 146–209.]

— (1979). Bréal versus Schleicher: linguistics and philology during the latter half of the 19th century. In Henry M. Hoenigswald (ed.), *The European Background of American Linguistics: Papers from the 3rd Golden Anniversary Symposium of the Linguistic Society of America* (pp. 63–106). Dordrecht: Foris. [Repr. in Aarsleff 1982, pp. 293–334.]

— (1982). *From Locke to Saussure: Essays on the Study of Language and Intellectual History*. Minneapolis: University of Minnesota Press.

Abler, William L. (1992). The serrated teeth of tyrannosaurid dinosaurs, and biting structures in other animals. *Paleobiology* 18(2), 161–83.

— (1999). The teeth of the tyrannosaurs. *Scientific American* 281(3), 50–1.

- Abraham, Werner (1991). The grammaticization of the German modal particles. In Traugott and Heine 1991b (pp. 331–80).
- Abraham, Werner, Epstein, Samuel D., Thráinsson, Höskuldur, and Zwart, Jan-Wouter (1996). *Minimal Ideas: Syntactic Studies in the Minimalist Framework*. Amsterdam: John Benjamins.
- Adams, Douglas (1980). *The Hitchhiker's Guide to the Galaxy*. New York: Harmony Books. [Ballantine Books edition, 1995.]
- Adams, M. P. (1987a). From Old French to the theory of Pro-drop. *Natural Language and Linguistic Theory* 5, 1–32.
- (1987b). Old French, null subjects, and verb second phenomena. Ph.D. dissertation, University of California, Los Angeles.
- Adams, Marilyn McCord (1987). *William Ockham, Volumes 1–2*. Notre Dame: University of Notre Dame Press. (Publications in Medieval Studies, 25.1–2.)
- Ager, Derek (1993). *The New Catastrophism: The Importance of the Rare Event in Geological History*. Cambridge: Cambridge University Press.
- Agostiniani, L., Bellucci Maffei, P., and Paoli, M. (eds) (1985). *Linguistica storica e cambiamento linguistico: atti del 16 congresso internazionale di studi [della Società di Linguistica Italiana], Firenze 7–9 maggio 1982*. Rome: Bulzoni.
- Aharonov, Yakir, Anandan, Jeeva S., Popescu, Sandu, and Vaidman, Lev (1990). Superpositions of time evolutions of a quantum system and a quantum time-translation machine. *Physical Review Letters* 64, 2965–8.
- Aitchison, Jean (1981). *Language Change: Progress or Decay*. London: Fontana. [2nd edn, Cambridge: Cambridge University Press, 1991. 3rd edn, Cambridge: Cambridge University Press, 2001.]
- (1989). *The Articulate Mammal: An Introduction to Psycholinguistics*. 3rd edn. London: Routledge. [1st edn 1976–7.]
- (1990). The missing link: the role of the lexicon. In Jacek Fisiak (ed.), *Historical Linguistics and Philology* (pp. 11–28). Berlin: Mouton de Gruyter.
- (1994). *Words in the Mind: An Introduction to the Mental Lexicon*. 2nd edn. Oxford: Blackwell.
- (1995). Tadpoles, cuckoos and multiple births: language contact and models of change. In Jacek Fisiak (ed.), *Linguistic Change under Contact Conditions* (pp. 1–13). Berlin: Mouton de Gruyter.
- (1996). *The Seeds of Speech: Language Origin and Evolution*. Cambridge: Cambridge University Press.
- (2000). Shuddering halt or sudden spurt? The linguistic development of (pre-)adolescents. In H. W. Kam and A. Pakir (eds), *Recent Developments and Issues in Applied Linguistics: A Collection of SAAL (Singapore Association for Applied Linguistics) Lectures* (pp. 97–111). Singapore: EPB.
- Aitchison, Jean and Bailey, Guy (1979). Unhappiness about not unhappy people. *Journal of Linguistics* 15, 245–66.
- Albritton, Claude C., Jr (ed.) (1967a). *Uniformity and Simplicity: A Symposium on the Principle of the Uniformity of Nature* (Geological Society of America, corporate ed.). New York: Geological Society of America. (Geological Society of America, Symposium Series, Special Papers, 89.)
- (1967b). Uniformity, the ambiguous principle. In Albritton 1967a (pp. 1–2).
- (ed.) (1975). *Philosophy of Geohistory, 1785–1970*. Stroudsburg: Dowden, Hutchinson, and Ross. (Benchmark Papers in Geology, 13.)
- (1989). *Catastrophic Episodes in Earth History*. London: Chapman and Hall. (Topics in the Earth Sciences.)

- Alekseev, M. E. (1994). Budukh. In Smeets 1994 (pp. 259–96).
- Alexander, Ronelle (1993). Remarks on the evolution of South Slavic prosodic systems. In Robert A. Maguire and Alan Timberlake (eds), *American Contributions to the Eleventh International Congress of Slavists, Bratislava, August–September 1993: Literature, Linguistics, Poetics* (pp. 181–201). Columbus: Slavica.
- Allen, Cynthia (1980). *Topics in Diachronic English Syntax*. New York: Garland.
- (1995). *Case Marking and Reanalysis: Grammatical Relations from Old to Early Modern English*. Oxford: Clarendon Press.
- Allen, W. Sidney (1951). Some prosodic aspects of retroflexion and aspiration in Sanskrit. *Bulletin of the School of Oriental and African Studies* 13, 939–46.
- (1976). The PIE aspirates: phonetic and typological factors in reconstruction. In Alphonse Juillard, Andrew M. Devine, and Laurence D. Stephens (eds) *Linguistic Studies Offered to Joseph Greenberg* (pp. 237–47). Saratoga: Anma Libri.
- (1994). Comparative reconstruction. In Asher and Simpson 1994 (vol. 2, pp. 636–43).
- Allerton, D. J. and Cruttendon, Alan (1974). English sentence adverbials: their syntax and their intonation in British English. *Lingua* 34, 1–30.
- Altenderfer, Mark (1996). Typological analysis. In Fagan 1996 (pp. 727–8).
- Altmann, Gabriel H., v. Buttler, H., Rott, W., and Strauss, U. (1983). A law of change in language. In B. Brainerd (ed.), *Historical Linguistics* (pp. 104–15). Bochum: Studienverlag Dr. N. Brockmeyer.
- Alvarez, Luis W., Alvarez, Walter, Asaro, F., and Michel, H. V. (1980). Extraterrestrial cause for the Cretaceous–Tertiary extinction. *Science* 208, 1095–108.
- Alvarez, Walter (1997). *T. Rex and the Crater of Doom*. Princeton, NJ: Princeton University Press.
- Ambrosini, R. (1980). Nuove tendenze nella linguistica storica: verso una nuova linguistica storica o verso una linguistica nuova?. In Mazzuoli Porru 1980 (pp. 11–39).
- Amsterdamska, Olga (1987). *Schools of Thought: The Development of Linguistics from Bopp to Saussure*. Dordrecht and Boston: D. Reidel. Distributed in the USA and Canada by Kluwer Academic.)
- Andersen, Henning (1973). Abductive and deductive change. *Language* 49(4), 765–93.
- (1974). Towards a typology of change: bifurcating changes and binary relations. In Andersen and Jones 1974b (pp. 17–60).
- (1978). Perceptual and conceptual factors in abductive innovations. In Jacek Fisiak (ed.), *Recent Developments in Historical Phonology* (pp. 1–22). The Hague: Mouton.
- (1980). Morphological change: towards a typology. In Fisiak 1980 (pp. 1–50).
- (1987). From auxiliary to desinence. In Martin B. Harris and Paolo Ramat (eds), *Historical Development of Auxiliaries* (pp. 21–51). Berlin: Mouton de Gruyter.
- (1989). Understanding linguistic innovations. In Breivik and Jahr 1989 (pp. 5–27).
- (1990). The structure of drift. In Andersen and Koerner 1990 (pp. 1–20).
- (1998). Dialektnaja differencijacija obščeslavjans kogo jazyka. Paradoks obščix tendencij razvitija s različnymi lokal'nymi rezul'tatami. In Robert Maguire and Alan H. Timberlake (eds), *American Contributions to the 12th International Congress of Slavists; Cracow, 27 August–2 September 1998* (pp. 565–600). Bloomington: Slavica.
- Andersen, H. and Koerner, E. F. K. (eds) (1990). *Historical Linguistics 1987: Papers from the 8th International Conference on Historical Linguistics (Lille)*. Amsterdam: John Benjamins.
- Anderson, Edgar and Stebbins, George Ledyard, Jr (1954). Hybridization as an evolutionary stimulus. *Evolution* 8, 378–88. [Repr. in Jameson 1977 (pp. 276–86).]

- Anderson, James M. (1991). Historical Linguistics. In Kirsten Malmkjaer and James M. Anderson (eds), *The Linguistics Encyclopedia* (pp. 189–216). London: Routledge.
- Anderson, John M. (1971). *The Grammar of Case: Towards a Localistic Theory*. London and New York: Cambridge University Press.
- (1973). *An Essay Concerning Aspect: Some Considerations of a General Character Arising from the Abbé Darrigol's Analysis of the Basque Verb*. The Hague and Paris: Mouton de Gruyter. (*Janua Linguarum, Series Minor*, 167.)
- Anderson, John M. and Jones, Charles (eds) (1974a). *Historical Linguistics*. Amsterdam: North-Holland. (ICHL 1, vol. 1.)
- (1974b). *Historical Linguistics*. Amsterdam: North-Holland. (ICHL 1, vol. 2.)
- (1977). *Phonological Structure and the History of English*. Amsterdam: North-Holland.
- Anderson, Stephen (1975). On the interaction of phonological rules of various types. *Journal of Linguistics* 11(1), 39–62.
- (1980). On the development of morphology from syntax. In Fisiak 1980 (pp. 51–69).
- (1981). Why phonology isn't "natural." *Linguistic Inquiry* 12, 493–539.
- (1985). *Phonology in the Twentieth Century: Theories of Rules and Theories of Representations*. Chicago: University of Chicago Press.
- (1988). Morphological change. In Newmeyer 1988 (pp. 324–62).
- (1992). *A-morphous Morphology*. Cambridge: Cambridge University Press. (CSL 62.)
- Andresen, Julie T. (1990). Skinner and Chomsky thirty years later. *Historiographia Linguistica: International Journal for the History of the Language Sciences/Revue Internationale pour l'Histoire* 17(1–2), 145–65.
- Andrews, Avery (1971). Case agreement of predicate modifiers in ancient Greek. *Linguistic Inquiry* 2, 127–52.
- Antinucci, Francesco, Duranti, Alessandro, and Gebert, Lucyna (1979). Relative clause structure, relative clause perception, and the change from SOV to SVO. *Cognition* 7, 145–76.
- Anttila, Arto (1997). Deriving variation from grammar. In Hinskens et al. 1997 (pp. 35–68).
- Anttila, Arto and Young-mee Yu Cho (1998). Variation and change in Optimality Theory. *Lingua* 104, 31–56.
- Anttila, Raimo (1972). *An Introduction to Historical and Comparative Linguistics*. New York: Macmillan.
- (1977). *Analogy*. The Hague: Mouton de Gruyter.
- (1989). *Historical and Comparative Linguistics*. Amsterdam and Philadelphia: John Benjamins. (CILT, 6.) [1st edn. pub. as Anttila 1972.]
- (1992a). Field theory of meaning and semantic change. In Kellermann and Morrissey 1992 (pp. 23–83). [Prepub. as LAUD, Series A, Paper No. 301, Linguistic Agency, University of Duisburg, 1991.]
- (1992b). Historical explanation and historical linguistics. In Garry W. Davis and Gregory K. Iverson (eds), *Explanation in Historical Linguistics* (pp. 17–39). Amsterdam and Philadelphia: John Benjamins.
- (1993). Change and metatheory at the beginning of the 1990s: the primacy of history. In Jones 1993 (pp. 43–73).
- Anttila, Raimo and Brewer, Warren A. (1977). *Analogy: A Basic Bibliography*. Amsterdam: John Benjamins.
- Anttila, Raimo and Embleton, Sheila (1995). The iconic index: from sound change to rhyming slang. In Raffaele Simone (ed.), *Iconicity in Language* (pp. 87–118). Amsterdam and Philadelphia: John Benjamins. [Earlier version, *Diachronica* 6, 155–80, 1989.]

- Archangeli, Diane (1984). Underspecification in Yawelmani phonology and morphology. Ph.D. dissertation, MIT. [Pub. New York: Garland, 1988.]
- (1988). Aspects of underspecification theory. *Phonology* 5, 183–208.
- (1997). Optimality Theory: an introduction to linguistics in the 1990s. In Archangeli and Langendoen 1997 (pp. 1–32).
- Archangeli, Diane and Langendoen, D. Terence (1997). *Optimality Theory: An Overview*. Oxford: Blackwell.
- Archangeli, Diane and Pulleyblank, Douglas (1989). Yoruba vowel harmony. *Linguistic Inquiry* 20, 173–217.
- Arends, Jacques (1986). Genesis and development of the equative copula in Sranan. In Muysken and Smith 1986 (pp. 103–27).
- Arens, Hans (1969). *Sprachwissenschaft: Der Gang ihrer Entwicklung von der Antike bis zur Gegenwart*. 2nd rev. edn. Freiburg and Munich: Alber.
- Ariès, Philippe (1962). *Centuries of Childhood: A Social History of Family Life*. New York: Knopf.
- Aristotle (c.330 BC). *Ēthikôn Nikomakheîôn biblia deka*. [Trans. H. Harris Rackham as *The [Ten Books of] Nichomachean Ethics*. Cambridge, MA: Harvard University Press, 1934. 1st edn 1926. (Loeb Classical Library L287: Aristotle, vol. 19.)]
- (c.350 BC). *Analutikâ hústera; Topiká*. [Trans. Hugh Tredennick and Edward Seymour Foster as *Posterior Analytics and Topica*, Cambridge, MA: Harvard University Press, 1960. (Aristotle in 23 volumes, 2; Loeb Classical Library, 391.)]
- Arlotto, Anthony (1972). *Introduction to Historical Linguistics*. Boston: Houghton-Mifflin. [Repr. Washington, DC: University Press of America, 1981.]
- Armstrong, David F., Stokoe, William F., and Wilcox, Sherman E. (1995). *Gesture and the Nature of Language*. Cambridge: Cambridge University Press.
- Arnovick, Leslie K. (1999). *Diachronic Pragmatics: Seven Case Studies in English Illocutionary Development*. Amsterdam and Philadelphia: John Benjamins.
- Aronoff, Mark (1994). *Morphology by Itself: Inflectional Classes*. Cambridge, MA: MIT Press.
- Asher, Ronald E. and Simpson, James M. Y. (eds) (1994). *The Encyclopedia of Language and Linguistics, Volumes 1–10*. Oxford: Pergamon.
- Åstrom, Paul (1995). *Oscar Montelius, 150 Years: Proceedings of a Colloquium held in the Royal Academy of Letters, History and Antiquities, Stockholm, 13 May 1993*. Stockholm: Kungl. Vitterhets, historie och antikvitets akademien. (Distributed by Almquist and Wiksell International.)
- Auden, Wystan Hugh (1962). Reading. In *The Dyer's Hand, and Other Essays* (pp. 3–12). New York: Random House.
- Auger, J. (1994). Pronominal clitics in Quebec colloquial French: a morphological analysis. Ph.D. dissertation, University of Pennsylvania.
- Augustinus (Augustine), Aurelius (saint, bishop of Hippo) (c.400). *Confessionum libri 13*. Manuscripts, Hippo (North Africa). [Critical edn, ed. Martin Skutella, Stuttgart: B. G. Teubner, 1934. Corrected revision, eds H. Juergens and W. Schaub, 1981. (Bibliotheca scriptorum Graecorum et Romanorum Teubneriana.) Trans. V. J. Bourke as *Confessions*, New York: Fathers of the Church, 1953. (Fathers of the Church, 21.)]
- Auroux, Sylvain, Koerner, Ernst Frideryk Konrad, Nederehe, Hans-Josef, and Versteegh, Kees (eds) (2000ff). *History of the Language Sciences: An International Handbook on the Evolution of the Study of Language from the Beginnings to the Present, Volumes 1ff*. Berlin: Mouton de Gruyter. (Handbücher zur Sprach- und Kommunikationswissenschaft.)
- Avisé, John C., Nelson, W. S., and Sugita, H. (1994). A speciation history of “living fossils”: molecular evolutionary patterns in horseshoe crabs. *Evolution* 48, 1986–2001.

- Axmaker, Shelley, Jaisser, Annie, and Singmaster, Helen (eds) (1988). BLS 14, nos 1 and 2. *Parasession on Grammaticalization*. University of California, Berkeley, Department of Linguistics.
- Ayala, Francisco (1983). Microevolution and macroevolution. In Bendall 1983 (pp. 387–402).
- Ayto, John (1990). *The Longman Register of New Words, Volume 2*. London: Longman.
- Bach, Emmon and King, Robert D. (1970). Umlaut in Modern German. *Glossa* 4, 3–21.
- Backus, Albert M. (1996). *Two in One: Bilingual Speech of Turkish Immigrants in the Netherlands*. Tilburg: Tilburg University Press.
- Baggioni, Daniel (1996). Hugo Schuchardt. In Stammerjohann et al. 1996 (pp. 842–3).
- Bailey, Charles-James N. (1973). *Variation and Linguistic Theory*. Washington, DC: Center for Applied Linguistics.
- (1982). *On the Yin and Yang Nature of Language*. Ann Arbor: Karoma.
- (1985). *English Phonetic Transcription*. Arlington: Summer Institute of Linguistics.
- Bailey, Guy and Maynor, Natalie (1988). Decreolization? *Language in Society* 16(4), 449–73.
- Bailey, Guy, Maynor, Natalie, and Cukor-Avila, Patricia (1989). Variation in subject-verb concord in Early Modern English. *Language Variation and Change* 1(3), 285–300.
- Bailey, Guy, Wikle, Tom, Tillery, Jan, and Sand, Lori (1991). The apparent time construct. *Language Variation and Change* 3(3), 241–64.
- (1993). Some patterns of linguistic diffusion. *Language Variation and Change* 5(3), 359–90.
- Bailyn, Bernard (1986). *Voyagers to the West: A Passage in the Peopling of America on the Eve of the Revolution* (Barbara DeWolfe, asst). New York: Knopf. (Distributed by Random House [Vintage Books].) [Repr. Borzoi Books, 1988.]
- (1987). *The Peopling of British North America: An Introduction*. New York: Knopf. [Borzoi Books; previously pub. Cambridge, MA: Charles Warren Center for Studies in American History, Harvard University, 1986. (Perspectives in American History.)]
- Baker, Mark C. (1996). *The Polysynthesis Parameter*. Oxford: Oxford University Press.
- Baker, Philip, and Syea, Anand (eds) (1996). *Changing Meanings, Changing Functions: Papers Relating to Grammaticalization in Contact Languages*. London: University of Westminster Press. (Westminster Creolistics Series, 2.)
- Baker, Victor Richard (ed.) (1981). *Catastrophic Flooding: The Origin of the Channeled Scablands*. Shroudsburg, PA: Dowden, Hutchinson, and Ross. (Distributed by Academic Press, New York.) (Benchmark Papers in Geology, 55.)
- (1998). Catastrophism and uniformitarianism: logical roots and current relevance in geology. In Blundell and Scott 1998 (pp. 171–82).
- Baker, Victor R. and Nummedal, Dag (eds) (1978). *The Channeled Scabland: A Guide to the Geomorphology of the Columbia Basin, Washington, Prepared for the Comparative Planetary Geology Field Conference held in the Columbia Basin; June 5–8, 1978*. Washington, DC: Planetary Geology Program, Office of Space Science, NASA.
- Bakker, Peter (1992). “A language of our own”: the genesis of Michif – the mixed Cree–French language of the Canadian Métis. Ph.D. dissertation, University of Amsterdam.
- Bakker, Peter and Papen, Robert A. (1997). Michif: a mixed language based on Cree and French. In Sarah G. Thomason (ed.), *Contact Languages: A Wider Perspective* (pp. 295–363). Amsterdam and Philadelphia: John Benjamins.
- Bakker, Robert T. (1975). Dinosaur renaissance. *Scientific American* 233(4), 58–72, 77–8 (plus 3, 4, 15a, 148).

- (1986). *The Dinosaur Heresies: New Theories Unlocking the Mysteries of the Dinosaurs and their Extinction*. New York: William Morrow.
- Baldi, Philip (ed.) (1991). *Patterns of Change, Change of Patterns: Linguistic Change and Reconstruction Methodology*. Berlin: Mouton de Gruyter.
- Baldi, Philip and Werth, Ronald M. (eds) (1978). *Readings in Historical Phonology*. University Park: Pennsylvania State University Press.
- Bally, Charles (1913). *Le langage et la vie*. Geneva: Édition Atar.
- Bammesberger, Alfred (ed.) (1988). *Die Laryngalthorie*. Heidelberg: Carl Winter.
- Bănescu, N. (1915). *Die Entwicklung des griechischen Futurums von der frühbyzantinischen Zeit bis zur Gegenwart*. Bucharest: Königliche Hofbuchdruckerei F. Göbl Söhne.
- Barber, Charles Laurence (1964). *Linguistic Change in Present-Day English*. University, AL: University of Alabama Press.
- (1976). *Early Modern English*. London: André Deutsch.
- Barbosa, Pilar, Fox, Danny, Hagstrom, Paul, McGinnis, Martha, and Pesetsky, David (eds) (1998). *Is the Best Good Enough? Optimality and Competition in Syntax*. Cambridge, MA: MIT Press and MIT Working Papers in Linguistics.
- Barbour, Julian B. (2000). *The End of Time: The Next Revolution in Physics*. Oxford: Oxford University Press. [Originally pub. London: Weidenfeld and Nicholson (Orion Publishing Group), 1999.]
- Barigozzi, Claudio (ed.) (1982). *Mechanisms of Speciation: Proceedings from the International Meeting on Mechanisms of Speciation, Sponsored by the Accademia nazionale dei Lincei; May 4–8, 1981; Rome, Italy*. New York City, NY: Alan R. Liss. (Progress in Clinical and Biological Research, 96.)
- Baron, Naomi (1977). *Language Acquisition and Historical Change*. Amsterdam: North-Holland.
- Barrère, Albert and Leland, Charles G. (eds) (1897). *A Dictionary of Slang, Jargon, and Cant*. London: George Bell and Sons.
- Barrett, Martyn (1995). Early lexical development. In Fletcher and MacWhinney 1995 (pp. 362–92).
- Bartholomew, M. (1973). Lyell and evolution: an account of Lyell's response to the project of an evolutionary ancestry for man. *British Journal for the History of Science* 6, 261–303.
- Bartlett, John R. (1877). *Dictionary of Americanisms*. Boston: Little, Brown.
- Barton, N. H. and Charlesworth, Brian (1984). Genetic revolutions, founder effects, and speciation. *Annual Review of Ecological Systematics* 15, 133–64.
- Baskett, William Denny (1920). *Parts of the Body in the Later Germanic Dialects*. Chicago: University of Chicago Press.
- Bately, Janet (ed.) (1980). *The Old English Orosius*. London: Oxford University Press, for the Early English Text Society. (SS [Early English Text Society], 6). [Also known as *King Alfred's [(of England; 849–899) Commissioned] Translation of [Paulus] Orosius, Adversus paganos historiarum libri septem (c.600 AD)*.]
- Bates, Elizabeth, Dale, Philip S., and Thal, Donna (1995). Individual differences and their implications for theories of language development. In Fletcher and MacWhinney 1995 (pp. 96–151).
- Battye, Adrian and Roberts, Ian G. (eds) (1995). *Clause Structure and Language Change*. Oxford: Oxford University Press.
- Bauer, Brigitte L. M. (1995). *The Emergence and Development of SVO Patterning in Latin and French*. Oxford: Oxford University Press.
- Bauer, Laurie (1994). *Watching English Change: An Introduction to the Study of Linguistic Change in Standard Englishes in the Twentieth Century*. London and New York: Longman.

- Beaken, Mike (1996). *The Making of Language*. Edinburgh: Edinburgh University Press.
- Becker, Thomas (1990). *Analogie und morphologische Theorie*. Munich: Fink.
- Beckmann, Jan Peter (1990). Ontologisches Prinzip oder methodologische Maxime? Ockham und der Ökonomiegedanke einst und jetzt. In Wilhelm Vossenkuhl and Rolf Schönberger (eds), *Die Gegenwart Ockhams* (pp. 191–207). Weinheim: VCH Acta Humaniora.
- (1992). *Ockham-Bibliographie 1900–1990*. Hamburg: Felix Meiner.
- Beddor, Patrice Speeter, Krakow, Rena Arens, and Goldstein, Louis M. (1986). Perceptual constraints and phonological change: a study of nasal vowel height. *Phonology Yearbook* 3, 197–217.
- Bencze, Lóránt (1989). Uncertainty principle and symmetry in metaphors. *Computers and Mathematics, with Applications* 17, 697–708.
- Bendall, Derek S. (ed.) (1983). *Evolution from Molecules to Men*. Cambridge: Cambridge University Press.
- Benedict, Paul K. (1990). *Japanese/Austro-Tai*. Ann Arbor: Karoma.
- Benét, William Rose and Murphy, Bruce (1996) *Benét's Reader's Encyclopedia*. 4th edn, rev. B. Murphy. New York: HarperCollins. [1st edn by W. R. Benét, 1948.]
- Bengtson, John (1989). On the fallacy of “diminishing returns” in long range lexical comparison. In Vitaly Shevoroshkin (ed.), *Reconstructing Languages and Cultures: Materials from the First International Interdisciplinary Symposium on Language and Prehistory* (pp. 30–3). Bochum: Brockmeyer.
- Benson, Richard H. (1984). Perfection, continuity, and common sense in historical geology. In Berggren and Van Couvering 1984 (pp. 35–75).
- Benton, Michael J. and Harper, David A. T. (1997). *Basic Palaeontology*. London: Addison Wesley Longman.
- Benveniste, Émile (1966). “Être” et “avoir” dans leur fonctions linguistiques. In Émile Benveniste (ed.), *Problèmes de linguistique générale* (vol. 1, pp. 187–207). Paris: Gallimard.
- (1968). Mutations of linguistic categories. In Lehmann and Malkiel 1968 (pp. 83–94).
- (1969). *Le vocabulaire des institutions indo-européennes*. Paris: Éditions de Minuit.
- Berggren, W. A. and Van Couvering, John A. (eds) (1984). *Catastrophes and Earth History: The New Uniformitarianism*. Princeton, NJ: Princeton University Press.
- Bergsland, Knut (1986). Comparative Eskimo–Aleut phonology and lexicon. *Aikakauskirja/Journal de la Société finno-ougrienne* 80, 63–137.
- (1989). Comparative aspects of Aleut syntax. *Aikakauskirja/Journal de la Société finno-ougrienne* 82, 7–80.
- (1994). *Aleut Dictionary: Unangam Tunudgusii*. Fairbanks: Alaska Native Language Center.
- (1997). How did the Aleut language become different from the Eskimo languages? In Osahito Miyaoka and Minoru Oshima (eds), *Languages of the North Pacific Rim* 2 (pp. 1–18). Kyoto: Graduate School of Letters, Kyoto University.
- Bergsland, Knut and Vogt, Hans (1962). On the validity of glottochronology. *Current Anthropology* 3, 115–53.
- Beringer, Carl Christoph (1954). *Geschichte der Geologie und des geologischen Weltbildes*. Stuttgart: F. Enke.
- Bernstein, Cynthia and Gregory, Elizabeth (1994). The social distribution of glide shortened /ai/ in *Linguistic Atlas of the Gulf States*. Paper presented at South Eastern Conference on Linguistics 50, Memphis, TN.
- Bernstein, Judy (1993). Topics in the syntax of nominal structure across Romance. Ph.D. dissertation, City University of New York.

- Bernstein, Leonard, Wilbur, Richard, Hellman, Lillian, Latouche, John, and Parker, Dorothy (1955). *Make our garden grow*. In *Candide, A Comic Operetta in Two Acts* (pp. 451–62). New York: Jalni Publications. (Boosey and Hawkes, sole agent.) (Vocal score.)
- Best, Karl-Heinz (1973). *Probleme der Analogieforschung*. Munich: Max Huber.
- Besten, Hens and Edmondson, J. A. (1983). The verbal complex in continental West Germanic. In Werner Abraham (ed.), *On the Formal Syntax of the Westgermania* (pp. 155–216). Amsterdam: Benjamins. (Papers from the 3rd Groningen Grammar Talks, Groningen, January 1981.)
- Bethin, Christina Y. (1998). *Slavic Prosody: Language Change and Phonological Theory*. Cambridge and New York: Cambridge University Press. (CSL 86.)
- Bever, Thomas G., Carroll, J. B., and Hurtig, Richard R. (1977). Analogy: or ungrammatical sequences that are utterable and comprehensible are the origins of new grammars in language acquisition and linguistic evolution. In T. G. Bever, Jerrold J. Katz, and D. Terence Langendoen (eds), *An Integrated Theory of Linguistic Ability* (pp. 149–82). Hassocks: Harvester. [1st pub. New York: Crowell, 1976.]
- Bever, Thomas G. and Langendoen, D. Terence (1972). The interaction of speech perception and grammatical structure in the evolution of language. In Robert P. Stockwell and Ronald K. S. Macaulay (eds), *Linguistic Change and Generative Theory* (pp. 32–95). Bloomington: Indiana University Press.
- Bhandarkar, Ramkrishna G. (1877–8). *Wilson Philological Lectures on Sanskrit and the Derived Languages. Delivered 1877* (rev. 1878). [Repr. 1974. (Post-Graduate and Research Department Series, 11.)]
- Bichakjian, Bernard H. (1988). *Evolution in Language*. Ann Arbor, MI: Karoma. (Linguistica Extranea, Studia, 18.)
- Bickel, Balthasar (1995). In the vestibule of meaning: transitivity inversion as a morphological phenomenon. *Studies in Language* 19(1), 73–128.
- (1999). Principles of event framing: genetic stability in grammar and discourse. University of California, Berkeley, manuscript. <http://socrates.berkeley.edu/~bickel/papers/events.pdf> hqx
- (2001). The syntax of experiencers in the Himalayas. In Peri Bhaskararao (ed.), *Working Papers of the International Symposium on Non-Nominative Subjects, Tokyo, Dec. 18–21, 2001* (pp. 207–37). Tokyo: Institute for the Study of Languages and Cultures of Asia and Africa.
- (2002). Referential density in discourse and syntactic typology. University of Leipzig manuscript.
- (forthcoming). Grammatical relations, agreement, and genetic stability.
- Bickerton, Derek (1973). The nature of a creole continuum. *Language* 49(3), 640–70.
- (1981). *Roots of Language*. Ann Arbor: Karoma.
- (1984). The language bioprogram hypothesis. *Behavioral and Brain Sciences* 7(2), 173–222.
- (1999). How to acquire language without positive evidence: what acquisitionists can learn from creoles. In De Graff 1999b (pp. 49–74).
- Biggs, Bruce (1965). Direct and indirect inheritance in Rotuman. *Lingua* 14, 383–445.
- Billings, Josh (1874). *Everybody's Friend, or Josh Billing's Encyclopedia and Proverbial Philosophy of Wit and Humor*. Hartford, CN: American Publishing.
- Bindseil, Heinrich E. (1838). *Abhandlungen zur allgemeinen vergleichenden Sprachlehre*. Hamburg: F. Perthes.
- Bisang, Walter (1996). Areal typology and grammaticalization: processes of grammaticalization based on nouns and verbs in East and mainland South East Asian languages. *Studies in Language* 20(3), 519–97.

- Bisang, Walter and Rinderknecht, Peter (eds) (1991). *Von Europa bis Ozeanien – von der Antonymie zum Relativsatz*. Zurich: Zurich University. (Arbeiten des Seminars für Allgemeine Sprachwissenschaft der Universität Zürich, 11.)
- Bittner, Andreas (1988). Reguläre Irregularitäten. Zur Suppletion in Konzept der natürlichen Morphologie. *Zeitschrift für Phonetik, Sprachwissenschaft und Kommunikationsforschung* 41(4), 416–25.
- (1996). *Starke “schwache” und schwache “starke” Verben: Deutsche Verbalflexion und Natürlichkeit*. Tübingen: Narr.
- Blackburn, Bonnie and Holford-Strevens, Leofranc (1999). *The Oxford Companion to the Year*. Oxford: Oxford University Press.
- Blackham, Harold John (1996). *The Future of Our Past: From Ancient Greece to Global Village*. Ed. Barbara Smoker. Amherst, NY: Prometheus Books.
- Blackmore, Susan J. (1999). *The Meme Machine*. Oxford: Oxford University Press.
- Bladon, R. A., Henton, C. G., and Pickering, J. B. (1984). Towards an auditory theory of speaker normalization. *Language and Communication* 4(1), 59–69.
- Blake, Barry J. (1994). *Case*. Cambridge: Cambridge University Press.
- Blakemore, Diane (1988). So as a constraint on relevance. In Ruth Kempson (ed.), *Mental Representation: The Interface between Language and Reality* (pp. 183–95). Cambridge: Cambridge University Press.
- Blevins, Juliette and Garrett, Andrew (1998). The origins of consonant–vowel metathesis. *Language* 74, 508–56.
- Bloemen, M. (1985). L’analisi diacronica del betacismo: alcune conseguenze per la teoria generativa del cambiamento linguistico. In Agostiniani and Paoli 1985 (pp. 363–96).
- Blom, J. P. and Gumperz, John J. (1972). Social meaning in linguistic structures: code-switching in Norway. In John J. Gumperz and Dell Hymes (eds), *Directions in Sociolinguistics* (pp. 407–34). New York: Holt, Rinehart, and Winston.
- Bloomer, Robert (1994). *System Congruity and the Participles of Modern German and Modern English: A Study in Natural Morphology*. Hamburg: Buske.
- Bloomfield, Leonard (1914). *An Introduction to the Study of Language*. New York: Holt, Rinehart, and Winston. [Repr. intro. Joseph F. Kess, Amsterdam and Philadelphia: John Benjamins, 1983.]
- (1925). On the sound system of Central Algonquian. *Language* 1, 130–56.
- (1928). A note on sound change. *Language* 4(1), 99–100.
- (1933). *Language*. New York: Holt, Rinehart, and Winston. [Repr. Chicago: Chicago University Press, 1984. Chapters on historical linguistics issued separately as *Language History*, New York: Holt, Rinehart, and Winston, 1965.]
- (1946). Algonquian. In Cornelius Osgood (ed.), *Linguistic Structures of Native America* (pp. 85–129). New York: Viking Fund.
- (1956). *Eastern Ojibwa*. Ann Arbor: University of Michigan Press.
- Blum, Harold F. (1968). *Time’s Arrow and Evolution*. Princeton, NJ: Princeton University Press. [3rd edn; 1st edn, 1951.]
- Blundell, D. J. and Scott, A. C. (eds) (1998). *Lyell: The Past is the Key to the Present*. London: Geological Society. (Special Publications 143.)
- Bobaljik, J. D. and Thráinsson, Höskuldur (1998). Two heads aren’t always better than one. *Syntax* 1, 37–71.
- Boehner, Philotheus (1957). Editor’s introduction. In William of Ockham, *Philosophical Writings: A Selection*, ed. and trans. Philotheus Boehner (pp. ix–li). Indianapolis: Nelson. (Nelson Philosophical Texts.) [Rev. ed. Stephen F. Brown, 1990.]
- Bogoras, Waldemar (1922). Chukchee. *Handbook of American Indian Languages* 2. *Bureau of American Ethnology Bulletin* 40, 631–903.

- Böhtlingk, Otto (ed.) (1870). *Indische Sprüche, Sanskrit und Deutsch, Band 1*. 2nd edn. St Petersburg. [Repr. Hildesheim: Georg Olms Verlag, 1966.]
- Boller, Paul F. Jr and George, John (eds) (1989). *They Never Said It*. New York: Oxford University Press.
- Boltzmann, Ludwig (1872). Weitere Studien über das Wärmegleichgewicht unter Gasmolekülen. *Sitzungsberichte der kaiserlichen Akademie der Wissenschaften in Wien, Klasse 2a* (66), 275–370.
- (1898). *Vorlesungen über Gastheorie, 2. Theil: Theorie van der Waals'; Gase mit zusammengesetzten Molekülen; Gasdissociation; Schlussbemerkungen*. Leipzig: J. A. Barth, 1898. [Trans. Stephen G. Brush as *Lectures on Gas Theory*, Berkeley: University of California Press, 1964.]
- Bomhard, Allan R. and Kerns, John C. (1994). *The Nostratic Macrofamily: A Study in Distant Linguistic Relationship*. Berlin: Mouton de Gruyter.
- Bonfante, Giuliano (1946). "Indo-Hittite" and areal languages. *American Journal of Philology* 67, 289–310.
- Boorstin, Daniel Joseph (1960). *America and the Image of Europe: Reflections on American Thought*. New York: Meridian, 1960. (Meridian Books, 89.) [Repr. Gloucester, MA: Peter Smith, 1976.]
- Bopp, Franz (1816). *Über das Conjugationssystem der Sanskritsprache in Vergleichung mit jenem der griechischen, lateinischen, persischen, und germanischen Sprache*. Frankfurt: Andreätschen.
- (1827). Über [Jacob] Grimms *Deutsche Grammatik II* [Göttingen: Dieterichsche Buchhandlung]. *Berliner Jahrbuch für wissenschaftliche Kritik* February and May: 251–303, 725–59. [Repr. in his *Vocalismus, oder sprachvergleichende Kritiken über J. Grimm's "Deutsche Grammatik" und Graff's "Althochdeutschen Sprachschatz", mit Begründung einer neuen Theorie des Ablauts*. Berlin: Nicolaische Buchhandlung, 1836.]
- (1833). *Vergleichende Grammatik des Sanskrit, Zend, Griechischen, Lateinischen, Litauischen, Altslawischen, Gothischen und Deutschen*, vol. 1. Berlin: F. Dümmler. [Trans. M. Bréal as *Grammaire comparée*. . . Paris, 1866.]
- Boretzky, Norbert (1977). *Einführung in die historische Linguistik*. Reinbek: Rowohlt.
- (1995). Natürlichkeitstheorie und sprachliche Interferenz. In Norbert Boretzky, Wolfgang U. Dressler, Janez Orešnik, Carmen Terzan, and Wolfgang Ullrich Wurzel (eds), *Natürlichkeitstheorie und Sprachwandel* (pp. 45–65). Bochum: Brockmeyer.
- Borges, Jorge Luis (1947). *Nueva refutación del tiempo*. Buenos Aires: Oportet and Haereses, 1947. [Repr. in *Otras inquisiciones (1937–1952)*. Buenos Aires: Sur, 1952. Trans. Ruth L. C. Simms as "A new refutation of time" in *Other Inquisitions, 1937–1952* (pp. 171–87). Austin, TX: University of Texas Press. (Texas Pan-American Series.) Repr. in *Obras completas, tomo 2: 1952–1972* (pp. 135–49). Barcelona: Emecé Editores, 1989.]
- Bosch, Peter (1985). Context dependence and metaphor. In W. Paprotté and R. Dirven (eds), *The Ubiquity of Metaphor: Metaphor in Language and Thought* (pp. 141–76). Amsterdam: John Benjamins.
- Bowden, John (1992). *Behind the Preposition: Grammaticalization of Locatives in Oceanic Languages*. Canberra: Australian National University. (Pacific Linguistics Series B, 107.) [M.A. thesis, University of Auckland, 1991.]
- Bowler, Peter J. (1976). *Fossils and Progress: Paleontology and the Idea of Progressive Evolution in the 19th Century*. New York: Science History Publications.
- Boyland, Joyce T. (1996). Morphosyntactic change in progress: a psycholinguistic approach. Ph.D. dissertation, University of California, Berkeley.

- Braithwaite, Richard Bevan (1953). *Scientific Explanation: A Study of the Function of Theory, Probability, and Law in Science (Based upon the Tanner Lectures, 1946)*. Cambridge: Cambridge University Press.
- Brandner, E. and Ferraresi, G. (eds) (1996). *Language Change and Generative Grammar*. Opladen: Westdeutscher Verlag.
- Bréal, Michel (1866). "[Translator's] Introduction." In 1866 trans. of Bopp 1833 (pp. xxxviii–xxxix). [Repr. in Bréal 1991 (pp. 18–49).]
- (1876). Examen critique de quelques théories relatives à la langue mère indo-européenne. *Journal des savants* 1876, 632–52. [Repr. in Bréal, *Mélange de mythologie et de linguistique*, Paris, 2nd edn, 1882, 1st edn, 1877 (pp. 375–411). Repr. in Bréal 1991 (pp. 93–110).]
- (1878). De l'analogie: mélanges publiés par la section historique et philologique. *Bibliothèque des hautes études, sciences philologiques et historiques* 35, 101–14. [Trans. reissue in Bréal 1991. Page refs are to the latter version.]
- (1991). *The Beginnings of Semantics*. Ed. and trans. George Wolf. Stanford: Stanford University Press.
- Bredsdorff, J. H. (1821). *Om Aarsagerne til Sproggenes Forandringer*. Copenhagen. [Trans. in Henning Andersen, "On the causes of linguistic change," *Historiographia Linguistica* 9, 1–23, 1982.]
- Breivik, Leiv Egil and Jahr, Ernst Håkon (eds) (1989). *Language Change: Contributions to the Study of its Causes*. Berlin: de Gruyter.
- Brenzinger, Matthias (1987). Die sprachliche und kulturelle Stellung der Mbugu (Ma'a). M.A. thesis, University of Cologne.
- Bresnan, Joan and Mchombo, Sam A. (1995). The Lexical Integrity Principle: evidence from Bantu. *Natural Language and Linguistic Theory* 13(2), 181–254.
- Bretz, Harlan (1923). The channeled scabland of the Columbia plateau. *Journal of Geology* 31, 617–49.
- Brewer, Douglas J. and Teeter, Emily (1999). *Egypt and the Egyptians*. Cambridge: Cambridge University Press.
- Bright, William (ed.) (1992). *Oxford International Encyclopedia of Linguistics*. Oxford: Oxford University Press.
- Brinton, Laurel J. (1988). *The Development of English Aspectual Systems*. Cambridge: Cambridge University Press. (CSL 49.)
- (1995). Pragmatic markers in a diachronic perspective. BLS 21.
- (1996). *Pragmatic Markers in English: Grammaticalization and Discourse Functions*. Berlin: Mouton de Gruyter.
- Britain, David (1992). Linguistic change in intonation: the use of high-rising terminals in New Zealand English. *Language Variation and Change* 4. [Repr. in Peter Trudgill and Jenny Cheshire (eds), *The Sociolinguistics Reader. Volume 1: Multilingualism and Variation* (pp. 213–39). London: Arnold, 1998.]
- British Broadcasting Corporation (BBC) Manchester and Worldwide, The Learning Channel (TLC) (Co-Producers), and Time-Life, Inc. (1988) *The Secret of Stonehenge*. Videocassette.
- Broad, Charlie Dunbar (1938). Ostensible temporality. In *Examination of McTaggart's Philosophy, Volume 2, Part 1*. Cambridge: [Cambridge] University Press. [Repr. in Gale 1967 (pp. 117–42).]
- Brody, J. L. (1989). Discourse markers in Tojolabal Mayan. CLS 25, no. 2, 15–29.
- Broe, Michael and Pierrehumbert, Janet (eds) (2000). *Acquisition and the Lexicon*. Cambridge: Cambridge University Press.

- Brogányi, Béla (1979). *Studies in Diachronic, Synchronic, and Typological Linguistics: Festschrift for Oswald Szemerényi on the Occasion of his 65th Birthday*. Amsterdam: John Benjamins. (CILT 11.)
- Bronstein, Arthur J., Raphael, Lawrence J., and Stevens, C. J. (eds) (1977). *A Biographical Dictionary of the Phonetic Sciences*. New York: Press of Lanham College.
- Brough, John (ed. and trans.) (1968). *Poems from the Sanskrit*. Harmondsworth: Penguin. (Penguin Classics.)
- Browman, C. P. and Goldstein, L. M. (1990). Tiers in articulatory phonology, with some implications for casual speech. In John C. Kingston and Mary E. Beckman (eds), *Papers in Laboratory Phonology 1: Between the Grammar and Physics of Speech* (pp. 341–76). Cambridge: Cambridge University Press.
- (1992). Articulatory phonology: an overview. *Phonetica* 49, 155–80.
- Brown, Cecil H. and Witkowski, Stanley R. (1979). Aspects of the phonological history of Mayan–Zoquean. *International Journal of American Linguistics* 45, 34–47.
- Brown, Lesley (ed.) (1993). *The New Shorter Oxford English Dictionary on Historical Principles*. Oxford: Clarendon Press.
- Brown, Roger and Gilman, Albert (1960). The pronouns of power and solidarity. In Sebeok 1960 (pp. 253–76).
- Brown, Vivian R. (1991). Evolution of the merger of /I/ and /E/ before nasals in Tennessee. *American Speech* 66, 303–15.
- Brugmann, Karl (1906). *Vergleichende Laut-, Stammbildungs- und Flexionslehre der indogermanischen Sprachen, 2:1*. Strasbourg: Trübner.
- Brunot, Ferdinand and Bruneau, Charles (1933). *Précis de grammaire historique de la langue française, entièrement refondu*. Paris: Masson.
- Bruyn, Adrienne (1995). *Grammaticalization in Creoles: The Development of Determiners and Relative Clauses in Sranan*. Amsterdam: Instituut voor Functioneel Onderzoek van Taal en Taalgebruik.
- (1996). On identifying instances of grammaticalization in creole languages. In Baker and Sycia 1996 (pp. 29–46).
- Bryson, Bill (1994). *Made in America: An Informal History of the English Language in the United States*. New York: William Morrow.
- Buck, Carl D. (1928). *A Grammar of Oscan and Umbrian*. Boston: Ginn.
- (1933). *Comparative Grammar of Greek and Latin*. Chicago and London: University of Chicago Press.
- Buckland, William (1836). *Geology and Mineralogy Considered with Reference to Natural Theology*. Philadelphia: Lea and Blanchard. [Rev. edn, 1841.]
- Buckley, Eugene (1999). On the naturalness of unnatural rules. In *Proceedings from the Second Workshop on American Indigenous Languages (Santa Barbara Papers in Linguistics, Volume 9)*, pp. 16–29.
- Burkhardt, Richard Wellington, Jr (1977). *The Spirit of System: [Jean-]Baptiste Pierre Antoine de Monet, Chevalier de Lamarck [1744–1829] and Evolutionary Biology*. Cambridge, MA: Harvard University Press.
- Burnham, Tom (1975). *The Dictionary of Misinformation*. New York: Ballentine.
- Burridge, Kate (1995). From modal auxiliary to lexical verb: the curious case of Pennsylvania German *wotte*. In Hogg and van Bergen 1995 (pp. 19–33).
- Burzio, Luigi (1986). *Italian Syntax*. Dordrecht: Reidel.
- Bush, G. L. (1975). Modes of animal speciation. *Annual Review of Ecology and Systematics* 6, 339–64.
- Butters, Ronald (1988). More on *za* and other foreclippings. *American Speech* 63, 1–33.

- Bybee, Joan L. (1985). *Morphology: A Study of the Relation between Meaning and Form*. (TSL 9.) Amsterdam and Philadelphia: John Benjamins.
- (1988). Semantic substance versus contrast in the development of grammatical meaning. *BLS* 14, 247–64.
- (1994). The grammaticalization of zero: asymmetries in tense and aspect systems. In Pagliuca 1994 (pp. 235–54).
- (1995). The development of past tense modals in English. In Bybee and Fleischman 1995 (pp. 503–17).
- (1998). The emergent lexicon. *CLS* 34, no. 1: *The Panels* (pp. 421–35).
- (2000a). The phonology of the lexicon: evidence from lexical diffusion. In M. Barlow and S. Kemmer (eds), *Usage-Based Models of Language* (pp. 65–85). Stanford: CSLI.
- (2000b). Lexicalization of sound change and alternating environments. In Broe and Pierrehumbert 2000 (pp. 250–68).
- (2001). *Phonology and Language Use*. Cambridge: Cambridge University Press. (CSL 94.)
- Bybee, Joan L. and Dahl, Östen (1989). The creation of tense and aspect systems in the languages of the world. *Studies in Language* 13(1), 51–103.
- Bybee, Joan and Fleischman, Suzanne (eds) (1995). *Modality in Grammar and Discourse*. Amsterdam and Philadelphia: John Benjamins. (TSL 32.)
- Bybee, Joan L. and Pagliuca, William (1985). Cross-linguistic comparison and the development of grammatical meaning. In Fisiak 1985 (pp. 59–83).
- (1987). The evolution of future meaning. In Anna Giacolone Ramat, Onofrio Carruba, and Giuliano Bernini (eds), *ICHL* 7 (pp. 109–22). Amsterdam: John Benjamins. (CILT 48.)
- Bybee, Joan L. and Scheibman, J. (1999). The effect of usage on degrees of constituency: the reduction of *don't* in English. *Linguistics* 37, 575–96.
- Bybee, Joan L. and Slobin, Dan I. (1982). Why small children cannot change language on their own: suggestions from the English past tense. In Anders Ahlqvist (ed.), *ICHL* 5 (pp. 29–37). Amsterdam: John Benjamins.
- Bybee, Joan L. and Thompson, Sandra A. (1997). Three frequency effects in English. *BLS* 23, 65–85.
- Bybee, Joan L., Perkins, Revere D., and Pagliuca, William (1991). Back to the future. In Traugott and Heine 1991b (pp. 17–58).
- (1994). *The Evolution of Grammar: Tense, Aspect, and Modality in the Languages of the World*. Chicago: University of Chicago Press.
- Bynon, Theodora (1977). *Historical Linguistics*. Cambridge and New York: Cambridge University Press. [Repr. with corrections and additional bibliography, 1983.] (Cambridge Textbooks in Linguistics.)
- (1994). Syntactic reconstruction. In Asher and Simpson 1994 (pp. 4468–71).
- Cable, Thomas (1990). Philology: analysis of written records. In Polomé 1990 (pp. 97–106).
- Cain, Arthur James (1954). *Animal Species and their Evolution*. London: Hutchinson. (University Library; Biology, 42). [3rd edn repr., Princeton, NJ: Princeton University Press, 1993.]
- Calebresi, Renata (1930). *La determinazione del presente psichico*. Florence: R. Bemporad.
- Callaghan, Catherine A. (1980). An “Indo-European” type paradigm in Proto Eastern Miwok. In Katherine Klar, Margaret Langdon, and Shirley Silver (eds), *American Indian and Indo-European studies: Papers in Honor of Madison S. Beeler* (pp. 331–8). The Hague: Mouton de Gruyter.

- (1997). Progress on the origin of language. *Diachronica* 14(2), 345–62.
- Callary, Robert (1975). Phonological change and the development of an urban dialect in Illinois. *Language in Society* 4, 155–70.
- Calvin, William H. and Bickerton, Derek (2000). *Lingua ex Machina: Reconciling Darwin and Chomsky with the Human Brain*. Cambridge, MA: MIT Press. (Bradford Books.)
- Campbell, Alistair (1962). *Old English Grammar*. Oxford: Clarendon Press. [Paperback repr. with corrections from the 1st edn of 1959, 1983.]
- Campbell, Lyle (1973). Distant genetic relationships and the Maya–Chipaya hypothesis. *Anthropological Linguistics* 15(3), 113–35.
- (1977). *Quichean Linguistic Prehistory*. Berkeley and Los Angeles: University of California Press. (*University of California Publications in Linguistics* 81.)
- (1987). Syntactic change in Pipil. *International Journal of American Linguistics* 53, 253–80.
- (1990). Syntactic reconstruction and Finno-Ugric. In Andersen and Koerner 1990 (pp. 51–94).
- (1991). Some grammaticalization changes in Estonian and their implications. In Traugott and Heine 1991a (pp. 285–99).
- (1995). The Quechumaran hypothesis and lessons for distant genetic comparison. *Diachronica* 12(2), 157–200.
- (1996). On sound change and challenges to regularity. In Durie and Ross 1996 (pp. 72–89).
- (1997a). *American Indian Languages: The Historical Linguistics of Native America*. New York and Oxford: Oxford University Press. (Oxford Studies in Anthropological Linguistics, 4.)
- (1997b). Amerind personal pronouns: a second opinion. *Language* 73, 339–51.
- (1998). Nostratic: a personal assessment. In Joseph and Salmons 1998 (pp. 107–52).
- (1999). *Historical Linguistics: An Introduction*. Cambridge, MA: MIT Press.
- (2001a). What's wrong with grammaticalization? In Campbell 2001b (pp. 113–61).
- (ed.) (2001b). *Grammaticalization: A Critical Assessment* (special issue of *Language Sciences* 23(2–3)).
- Campbell, Lyle and Janda, Richard (2001). Introduction: conceptions of grammaticalization and their problems. In Campbell 2001b (pp. 93–112).
- Campbell, Lyle, Kaufman, Terrence, and Smith-Stark, Thomas (1986). Meso-America as a linguistic area. *Language* 62(3), 530–70.
- Cannon, Walter F. (1960). The uniformitarian–catastrophist debate. *Isis* 51, 38–55.
- (1961). The impact of uniformitarianism: two letters from John Herschel to Charles Lyell, 1836–1837. *Proceedings of the American Philosophical Society* 105, 301–14.
- Čapek, Milič (1967). Change. In Edwards 1967 (vol. 2, pp. 75–9).
- Carden, Guy and Stewart, William A. (1988). Binding theory, bioprogram, and creolization: evidence from Haitian Creole. *Journal of Pidgin and Creole Languages* 3(1), 1–67.
- Carlson, Gregory N. (1977). Reference to kinds in English. Ph.D. dissertation, University of Massachusetts, Amherst. [Pub. New York: Garland, 1980. (Outstanding Dissertations in Linguistics series.)]
- Carozzi, A. V. (1964). Lamarck's theory of the earth: hydrogéologie. *Isis* 55, 293–307.
- Carstairs-McCarthy, Andrew (1988). Some implications of phonologically conditioned suppletion. *Yearbook of Morphology 1988*, 67–94.
- (1992). *Current Morphology*. London: Routledge.
- (1999). *The Origin of Complex Language: An Inquiry into the Evolutionary Beginnings of Sentences, Syllables, and Truth*. Oxford: Oxford University Press.

- (2001). Origins of language. In Mark Aronoff and Janie Rees-Miller (eds), *The Blackwell Handbook of Linguistics* (pp. 1–18). Oxford: Blackwell.
- Carter, Richard T., Jones, A. Wesley and Rankin, Robert L. (forthcoming). *Comparative Siouan Dictionary*. Database at the Siouan Archive, University of Colorado.
- Carver, Craig M. (1987). *American Regional Dialects: A Word Geography*. Ann Arbor: University of Michigan Press.
- Cassidy, Frederic G. (ed.) (1985). *Dictionary of American Regional English*. Cambridge, MA: Belknap Press of Harvard University Press.
- Casti, John L. (1994). *Complexification: Explaining a Paradoxical World through the Science of Surprise*. New York: HarperCollins.
- Cedergren, Henrietta J. (1973). The interplay of social and linguistic factors in Panama. Ph.D. dissertation, Cornell University.
- (1984). Panama revisited: sound change in real time. Paper presented at New Ways of Analyzing Variation in English, 13, University of Pennsylvania.
- Cedergren, Henrietta J. and Sankoff, David (1974). Variable rules: performance as a statistical reflection of competence. *Language* 50(2), 333–55.
- Cerrón-Palomino, Rodolfo (1974). Morphologically conditioned changes in Wanka Quechua. *Studies in the Linguistic Sciences* 4(2), 40–75.
- (1977). Cambios gramaticalmente condicionados en quechua: una desconfirmación de la teoría neogramática del cambio fonético. *Lexis: Revista de Lingüística y Literatura* 1, 163–84. Lima: Departamento de Humanidades, Pontífica Universidad Católica del Perú.
- (1987). *Lingüística quechua*. Cuzco: Centro de Estudios Rurales Andinos “Bartolomé de las Casas.” (Biblioteca de la tradición oral andina, 8.)
- Chadwick, John (1976). *The Mycenaean World*. Cambridge: Cambridge University Press.
- Chafe, Wallace (1985). Linguistic differences produced by differences between speaking and writing. In David Olsen, Nancy Torrance, and Angela Hildyard (eds), *Literacy, Language, and Learning* (pp. 105–23). Cambridge: Cambridge University Press.
- (1987). Cognitive constraints on information flow. In Russell Tomlin (ed.), *Coherence and Grounding in Discourse* (pp. 21–51). Amsterdam: John Benjamins.
- (1994). *Discourse, Consciousness, and Time: The Flow and Displacement of Conscious Experience in Speaking and Writing*. Chicago: University of Chicago Press.
- Chambers, J. K. (1993). Sociolinguistic dialectology. In Dennis R. Preston (ed.), *American Dialect Research* (pp. 133–64). Philadelphia: John Benjamins.
- (1995). *Sociolinguistic Theory*. Oxford: Blackwell.
- Chambers, J. K. and Trudgill, Peter (1980). *Dialectology*. Cambridge: Cambridge University Press. [2nd edn, 1998.]
- Charlesworth, Brian, Lande, Russell, and Slatkin, Montgomery (1982). A neo-Darwinian commentary on macroevolution. *Evolution* 36, 474–98.
- Charlton, William (1995). Change. In Honderich 1995 (p. 129).
- Chaudron, C. (1985). A method for examining the input/intake distinction. In Gass and Madden 1985 (pp. 285–300).
- Cheetham, Alan H. (1986). Tempo of evolution in a Neogene Bryozoan: rates of morphologic change within and across species boundaries. *Paleobiology* 12, 190–202.
- Chen, Matthew Y. and Wang, William S.-Y. (1975). Sound change: actuation and implementation. *Language* 51(2), 255–81.
- Cheng, C. C. and Wang, William S.-Y. (1977). Tone change in Chao-zhou Chinese: a study in lexical diffusion. *Project on Linguistic Analysis*, 12. Berkeley: University of California Phonology Laboratory. [Repr. in Wang 1977 (pp. 86–100).]

- Cheshire, Jenny (1982). *Variation in an English Dialect: A Sociolinguistic Study*. Cambridge: Cambridge University Press.
- Chesterton, G. K. (1929). *The Complete Father Brown*. New York: Penguin. [2nd edn 1981.]
- Chew, John J. (1989). The significance of geography in understanding the relationship of Japanese to other languages. In Irmela Hijiya-Kirschner and Jürgen Stalph (eds), *Bruno Lewin zu Ehren* (vol. 1, pp. 13–49). Bochum: Brockmeyer. (Bochumer Jahrbuch zur Ostasienforschung, 1989.)
- Chin, Karen, Tokaryk, Timothy T., Erickson, Gregory M., and Calk, Lewis C. (1998). A king-sized theropod coprolite. *Nature* 393, 680–2.
- Ching, M. (1982). The question intonation in assertions. *American Speech* 57, 95–107.
- Cho, Young-mee Yu (1990). Parameters of consonantal assimilation. Ph.D. dissertation, Stanford University.
- (2001). Language change and the phonological lexicon of Korean. In Laurel J. Brinton and Desiree Lundstrom (eds), *Historical Linguistics 1999: Selected Papers from the 14th International Conference on Historical Linguistics; Vancouver, 9–13 August 1999* (pp. 89–104). Amsterdam: John Benjamins.
- Chomsky, Noam (1957). Logical structures in language. *American Documentation* 8, 284–91.
- (1965). *Aspects of the Theory of Syntax*. Cambridge, MA: MIT Press.
- (1986). *Knowledge of Language: Its Nature, Origin and Use*. New York: Praeger.
- (1995). *The Minimalist Program*. Cambridge, MA: MIT Press.
- Chomsky, Noam and Halle, Morris (1968). *The Sound Pattern of English*. New York: Harper and Row.
- Chomsky, Noam and Lasnik, Howard (1993). The theory of principles and parameters. In J. Jacobs, Arnim von Stechow, W. Sternefeld, and Theo Vennemann (eds), *Syntax: An International Handbook of Contemporary Research* (pp. 506–69). Berlin: de Gruyter.
- Christdas, Pratima (1988). The phonology and morphology of Tamil. Ph.D. dissertation, Cornell University.
- Christie, William M., Jr (ed.) (1976). *Current Progress in Historical Linguistics: Proceedings of the Second International Conference on Historical Linguistics, Tucson, Arizona, 12–16 January 1976*. Amsterdam and New York: North-Holland.
- Christy, T. Craig (1983). *Uniformitarianism in Linguistics*. Amsterdam: John Benjamins.
- (1992). Geology and the science of language: metaphors and models. In Naumann et al. 1992 (pp. 79–89).
- Claridge, Michael F., Dawah, Hassan A., and Wilson, Michael R. (eds) (1997). *Species: The Units of Biodiversity*. London: Chapman and Hall. (Systematics Association Special Volumes, 54.)
- Clark, Robin (1992). The selection of syntactic knowledge. *Language Acquisition* 2, 2.
- Clark, Robin and Roberts, Ian G. (1993). A computational model of language learnability and language change. *Linguistic Inquiry* 24, 299–345.
- Clarkson, Euan Neilson Kerr (1979). *Invertebrate Paleontology and Evolution*. London: George Allen and Unwin. [2nd edn, 1986.]
- Claudi, Ulrike (1993). *Die Stellung von Verb und Objekt in Niger-Kongo-Sprachen: Ein Beitrag zur Rekonstruktion historischer Syntax* Cologne: Universität zu Köln, Institut für Afrikanistik. (AMO, Afrikanistische Monographien, 1.)
- (1994). Word order change as category change: the Mandé case. In Pagliuca 1994 (pp. 191–232).
- Claudi, Ulrike and Heine, Bernd (1986). On the metaphorical base of grammar. *Studies in Language* 10(2), 297–335.

- Clay, E. Robert (1882). *The Alternative: A Study in Psychology*. London: Macmillan.
- Cleland, Carol E. (1990). The difference between real change and mere Cambridge change. *Philosophical Studies* 60(3), 257–80.
- Clements, George N. (1985). The geometry of phonological features. *Phonology* 2, 225–52.
- Coates, Richard (1987). Pragmatic sources of analogical reformation. *Journal of Linguistics* 23(2), 319–40.
- Cole, Jennifer S. and Hualde, Jose Ignacio (1998). The object of acquisition: a UR-free model. *CLS* 34(2), 447–58.
- Cole, Peter (1982). *Imbabura Quechua*. Amsterdam: North-Holland. (Lingua Descriptive Studies.)
- Coleman, William (1964). *Georges Cuvier, Zoologist: A Study in the History of Evolution Theory*. Cambridge, MA: Harvard University Press.
- Collinge, Neil (1994a). Comparative linguistics: history. In Asher and Simpson 1994 (vol. 2, pp. 629–36).
- (1994b). Historical linguistics: history. In Asher and Simpson 1994 (vol. 3, pp. 1559–67).
- Collinge, Neville E. (1985). *The Laws of Indo-European*. Amsterdam and Philadelphia: John Benjamins.
- Collingwood, Robin George (1946). *The Idea of History*. Oxford: Clarendon Press. [Ed. and intro. Jan van der Dussen, 1993.]
- Colman, F. (1988). Heavy arguments in Old English. In J. M. Anderson and N. Macleod (eds), *Edinburgh Studies in the English Language* (pp. 33–89.) Edinburgh: John Donald.
- Comisión organizadora (ed.) (1925). *Homenaje ofrecido a Menéndez Pidal: miscelánea de estudios lingüísticos, literarios e históricos*. Madrid: Hernando.
- Company, C. (1995). Old forms for new concepts: the recategorization of possessive duplications in Mexican Spanish. In Henning Andersen (ed.), *ICHL 11* (pp. 77–103). Amsterdam: John Benjamins. (CILT 124.)
- Comrie, Bernard (1978). On the *go/went* alternation: a contribution (?) to the generative phonology of English. In T. Ernst and E. Smith (eds), *Lingua Franca* (pp. 59–63). Bloomington: Indiana University Linguistics Club.
- (1979). Morphophonemic exceptions and phonetic distance. *Linguistics* 17, 51–60.
- (1980). Morphology and word order reconstruction: problems and prospects. In Fisiak 1980 (pp. 83–96).
- (1981). *Language Universals and Linguistic Typology*. Chicago: University of Chicago Press.
- Comrie, Bernard and Smith, Norval (1977). *Lingua Descriptive Studies: Questionnaire*. *Lingua* 42, 1–72.
- Condillac, Étienne Bonnot de (1746). *Essai sur l'origine des connaissances humaines*. Paris. — (1749). *Traité des systèmes*. Paris.
- Constable, Nick (2000). *The World Atlas of Archaeology*. Intro. Brian Fagan. New York: Lyons Press. [First pub. Thalamus 1999.]
- Conway, R. S., Whatmough, J., and Johnson, S. E. (1933). *The Prae-Italic Dialects of Italy*. Cambridge, MA: Harvard University Press.
- Cook, Eung-Do (1995). Is there convergence in language death? Evidence from Chipewyan and Stoney. *Journal of Linguistic Anthropology* 5, 217–31.
- Corbett, Greville (1991). *Gender*. Cambridge: Cambridge University Press.
- Corder, S. Pit (1967). The significance of learners' errors. *International Review of Applied Linguistics* 5(4), 161–70.

- Coseriu, Eugenio (1952). Sistema, norma y habla. *Revista de la Facultad de Humanidades y Ciencias* (Montevideo) 9 (1952), 113–77. [Repr. in *Teoría del lenguaje y lingüística general: cinco estudios* (pp. 11–113), Madrid: Gredos, 1967. New edn, 1975.]
- (1958). *Sincronía, diacronía e historia. El problema del cambio lingüístico*. Madrid: Gredos. [2nd edn, 1974.]
- (1968). *Teoría del lenguaje y lingüística general; cinco estudios*. Madrid: Gredos. [Transl. Agostinho Dias Carneiro as *Teoria da linguagem e lingüística geral: cinco estudos*, Rio de Janeiro: Presença, 1979.]
- (1982). “Linguistic change does not exist.” Paper presented at the Conference on Causality and Linguistic Change, University of California at Los Angeles; May 28–30, 1982. [Repr. in his *Energeia und Ergon: Sprachliche Variation – Sprachgeschichte – Sprachtypologie; Band 1: Schriften . . . (1965–1987)*, ed. Jörn Albrecht (pp. 147–57), Tübingen: Gunter Narr, 1988. (Tübinger Beiträge zur Linguistik, 300.)]
- (1983). “Linguistic change does not exist.” *Linguistica nuova ed antica: Rivista di linguistica classica medioevale e moderna* 1, 51–63.
- Cottle, Basil (1978). *The Penguin Dictionary of Surnames*. 2nd edn. London: Penguin.
- Courtenay, William J. (1972–3). John of Mirecourt and Gregory of Rimini on whether God can undo the past. *Recherches de théologie ancienne et médiévale* 39, 224–56, and 40, 147–74.
- Cowan, William and Foster, Michael K. (eds) (1989). *E. F. Konrad Koerner Bibliography*. Bloomington: Eurolingua.
- Craig, Colette G. (1991). Ways to go in Rama: a case study in polygrammaticalization. In Traugott and Heine 1991b (pp. 455–92).
- Craig, W. L. (1988). Tachyons, time travel, and divine omniscience. *Journal of Philosophy* 85, 135–50.
- Crampton, H[enry] E[dward] (1917). *Studies on the Variation, Distribution, and Evolution of the Genus Partula: The Species Inhabiting Tahiti*. Carnegie Institution of Washington Publications 228, 1–311.
- (1925). *Studies on the Variation, Distribution, and Evolution of the Genus Partula: The Species of the Mariana Islands, Guam and Saipan*. Carnegie Institution of Washington Publications 228a, 1–116.
- (1932). *Studies on the Variation, Distribution, and Evolution of the Genus Partula: The Species Inhabiting Moorea*. Carnegie Institution of Washington Publications 410, 1–335.
- Crane, Tim (1995). Cambridge change. In Honderich 1995 (p. 115).
- Crick, Bernard R. (1970). Introduction. In Walker et al. 1970 (pp. 13–69).
- Croft, William (1990). *Typology and Universals*. Cambridge: Cambridge University Press.
- (1995). Intonation units and grammatical knowledge. *Linguistics* 33, 838–82.
- (2000). *Explaining Language Change: An Evolutionary Approach*. Harlow and New York: Longman.
- Crowley, Terry (1997). *An Introduction to Historical Linguistics*. Auckland: Oxford University Press.
- Crystal, David (1995). *The Cambridge Encyclopedia of the English Language*. Cambridge: Cambridge University Press.
- Cunningham, C. W., Blackstone, N. W., and Buss, Leo W. (1992). Evolution of king crabs from hermit crab ancestors. *Nature* 355, 539–42.
- Curtius, Georg (1877). *Das Verbum der griechischen Sprache seinem Baue nach dargestellt, Band 1*. 2nd edn. Leipzig: S. Hirzel. [vol. 2, 1880.] [Repr. Hildesheim: Gerstenberg Verlag, 1978. (Two vols bound as one.)]

- Dahl, Östen (1985). *Tense and Aspect Systems*. Oxford: Blackwell.
- Dalberg-Acton, John Emerich Edward (Lord Acton) (1895). The study of history. (Inaugural lecture as Regius Professor of Modern History, Cambridge University, June 11.) [Pub. as *Inaugural Lecture on the Study of History*. London: Macmillan, 1895ff. Repr. in his *Lectures on Modern History*, eds John Neville Figgis and Reginald Vere Laurence (pp. 1–28, 319–42). London: Macmillan, 1906. Repr. 1930. Repr. (rev.) with the prefaced title *Renaissance to Revolution*: New York: Schocken Books, 1961. Also New York: St Martin's Press and New York: Meridian Books, 1961, copyright 1960.]
- Dale, Richard (1851). Account of Bon Homme Richard and Serapis. In John Henry Sherburne, *The Life and Character of John Paul Jones*. 2nd edn. New York: Adriance, Sherman [Repr. as "I have not yet begun to fight." In Louis Leo Snyder and Richard Brandon Morris (eds), *They Saw It Happen: Eyewitness Reports of Great Events* (pp. 171–5). Harrisburg, PA: Stackpole.]
- Dancygier, B. (1992). Two metatextual operators: negation and conditionality in English and Polish. *BLS* 18, 61–5.
- Danesi, Marcel (1987). A Vichian footnote to Nietzsche's views on the cognitive primacy of metaphor: an addendum to Schrift. *New Vico Studies* 5, 157–64.
- (1990). Thinking is seeing: visual metaphors and the nature of abstract thought. *Semiotica* 80, 221–37.
- Darden, B. J. (1970). The fronting of vowels after palatals in Slavic. *Proceedings of the Regional Meeting, Chicago Linguistic Society* 6, 459–70.
- Darwin, Charles Robert (1859). *On the Origin of Species by Means of Natural Selection, Or The Preservation of Favoured Races in the Struggle for Life*. London: John Murray. [2nd edn, 1860. Facsimile edn (re)pr., intro. Ernst Mayr, Cambridge, MA: Harvard University Press, 1964.]
- Darwin, E. (1803). *The Temple of Nature*. London: J. Johnson.
- Dasher, R. B. (1995). Grammaticalization in the system of Japanese predicate honorifics. Ph.D. dissertation, Stanford University.
- Davies, Gordon L. (1969). *The Earth in Decay: A History of British Geomorphology 1578–1878*. New York: American Elsevier.
- Davis, Boyd H. and O'Cain, Raymond K. (eds) (1980). *1st-Person Singular [1]: Papers from the Conference on an Oral Archive for the History of American Linguistics (Charlotte, NC; 9–10 March 1979)*. Amsterdam: John Benjamins. (Studies in the History of Linguistics, 21.)
- Dawkins, R. M. (1916). *Modern Greek in Asia Minor: A Study of the Dialects of Silli, Cappadocia, and Phárasa*. Cambridge: Cambridge University Press.
- Dawkins, Richard (1976). *The Selfish Gene*. Oxford: Oxford University Press. [New edn, 1989.]
- (1978). Replicator selection and the extended phenotype. *Zeitschrift für Tierpsychologie* 47, 61–76.
- (1982). *The Extended Phenotype: The Gene as the Unit of Selection*. Oxford: Freeman. [Rev. as *The Extended Phenotype: The Long Reach of the Gene*, Oxford: Oxford University Press, 1999.]
- (1983). Universal Darwinism. In Bendall 1983 (pp. 403–35).
- (1986). *The Blind Watchmaker: Why the Evidence of Evolution Reveals a Universe Without Design*. New York: W. W. Norton. [Expanded edn, 1996.]
- (1996). *Climbing Mount Improbable*. New York: W. W. Norton.
- (1998). *Unweaving the Rainbow: Science, Delusion and the Appetite for Wonder*. Boston, MA: Houghton Mifflin.

- De Camp, David (1963). Review of Frederic G. Cassidy, 1961, *Jamaica talk*. London: Macmillan and Co. Ltd and New York: St Martin's Press. *Language* 39(3), 536–44.
- De Chene, E. Brent and Anderson, Stephen R. (1979). Compensatory lengthening. *Language* 55(3), 505–35.
- Decker, Robert W. and Decker, Barbara B. (1998). Volcanism. In *The New Encyclopaedia Britannica* (vol. 29 (Macropaedia), pp. 512–23). Chicago: Encyclopaedia Britannica.
- DeGraff, Michel (1999a). Creolization, language change, and language acquisition: an epilogue. In De Graff 1999b (pp. 473–543).
- (ed.) (1999b). *Language Creation and Language Change: Creolization, Diachrony, and Development*. Cambridge: MIT Press. (Learning, Development, and Conceptual Change Series.)
- DeLancey, Scott (1994a). Binary comparison? Posting 5.939, message 1, to LINGUIST (31 August 1994).
- (1994b). Re: 5.1393 Using the comparative method in syntax. Posting 5.1433, message 1, to LINGUIST (7 December 1994).
- Delbrück, Berthold (1880). *Einleitung in das Sprachstudium: Ein Beitrag zur Geschichte und Methodik der vergleichenden Sprachforschung*. Leipzig: Druck und Verlag von Breitkopf und Härtel. (Bibliothek indogermanischer Grammatiken, 4.) [6th edn 1919. Trans. Eva Channing as *Introduction to the Study of Language: A Critical Survey of the History and Methods of Comparative Philology of the Indo-European Languages*. Leipzig: Breitkopf und Härtel, 1882. Repr. ed. E[rnst] F[rideryk] K[onrad] Koerner, Amsterdam: John Benjamins, 1974. (Amsterdam Classics in Linguistics, 1800–1925, 8.)
- Delisle, Helga H. (1981). Consonantal symbolism in American Indian languages. *Journal of the Linguistic Association of the Southwest* 4, 130–42.
- De Mauro, Tullio De Mauro and Formigari, Lia (1990). *Leibniz, Humboldt, and the Origins of Comparativism*. With the assistance of Donatella Di Cesare, Raffaella Petrilli, and Anna Maria Thornton. Amsterdam: John Benjamins. (Studies in the History of the Language Sciences, 49.)
- Dening, Greg (1992). *Mr Bligh's Bad Language: Passion, Power, and Theatre on the "Bounty."* Cambridge: Cambridge University Press.
- Denison, D. (1993). *English Historical Syntax: Verbal Constructions*. London and New York: Longman.
- Dennett, Daniel Clement (1995). *Darwin's Dangerous Idea: Evolution and the Meanings of Life*. New York City, NY: Simon and Schuster.
- de Ronsard, Pierre (1555). Je vous envoye un bouquet. [In his *La continuation des Amours*, 1558. Repr. in his *Oeuvres complètes*, ed. Gustave Cohen (vol. 1, p. 814). Paris: Gallimard, 1965. 1st edn 1950.]
- Derwing, Bruce, Nearey, Terrance, and Dow, Maureen (1986). On the phoneme as the unit of the "second articulation." *Phonology (Yearbook)* 3, 45–69.
- de Saussure, Ferdinand (1879). *Mémoire sur le système primitif des voyelles dans les langues indo-européennes*. Leipzig: Teubner.
- (1916). *Cours de linguistique générale*. Eds Charles Bally, Albert Sèchehaye, and Albert Riedlinger. Paris: Payot. edn, 1916; critical edn, ed. Tullio de Mauro, 1972. [Repr. with a 1985 Postface by Louis-Jean Calvet, 1989. Trans. Roy Harris as *Course in General Linguistics*, 1983. Also ed. Rudolf Engler, 2 vols, 1967–8, 1974, Wiesbaden: Otto Harrassowitz.]
- Desmet, Piet (1996). *La linguistique naturaliste en France (1867–1922): nature, origine et évolution du langage*. Leuven: Peeters.
- Desnitskaja, Agnja V. (1972). August Schleicher als Sprachtheoretiker. In Harry Spitzbardt (ed.), *Synchronischer und diachronischer Sprachvergleich: Bericht über die Wissenschaftliche*

- Arbeitstagung zu Ehren des 150. Geburtstages von August Schleicher* (pp. 18–36). Jena: Friedrich-Schiller-Universität.
- Desrochers, Richard. (1994). Les liaisons dangereuses: le statut équivoque des erreurs de liaison. *Linguisticae Investigationes* 18(2), 243–84.
- Devitt, Dan (1990). The diachronic development of semantics in copulas. *BLS* 16, 103–15.
- (1994). Copula constructions in crosslinguistic and diachronic perspective. Ph.D. dissertation, SUNY, Buffalo.
- Dickerson, W. B. (1975). Variable rules in the speech community. *Studies in Linguistic Sciences* 5, 41–68.
- Dickinson, Goldsworthy Lowes (1931). *J. McT. E. McTaggart*. Cambridge: Cambridge University Press.
- Dieninghoff, J. (1904). *Die Umschreibungen aktiver Vergangenheit mit dem Participium Praeteriti im Althochdeutschen*. Bonn: Carl Georgi, Universitäts-Buchdruckerei.
- Diesing, Molly (1996). Semantic variables and object shift. In H. Thráinsson, S. D. Epstein, and S. Peter (eds), *Studies in Comparative German Syntax II* (pp. 66–84). Dordrecht: Kluwer.
- Diessel, Holger (1999). *Demonstratives: Form, Function, and Grammaticalization*. Amsterdam and Philadelphia: John Benjamins. (TSL 42.)
- Dietrich, Michael R. (1992). Macromutation. In Keller and Lloyd 1992 (pp. 194–201).
- Diewald, Gabriele (1997). *Grammatikalisierung: Eine Einführung in Sein und Werden grammatischer Formen*. Tübingen: Niemeyer.
- Dillehay, Thomas D. (2000). *The Settlement of the Americas: A New Prehistory*. New York: Basic Books.
- Dingwall, William O. (ed.) (1971). *A Survey of Linguistic Science*. College Park: University of Maryland Linguistics Program.
- D’Introno, F. and Sosa, J. M. (1986). Elisión de la /d/ en el español de Caracas: aspectos sociolingüísticos e implicaciones teóricas. In Rafael A. Núñez Cedeño, Iraset Páez Urdaneta, and Jorge M. Guitart (eds), *Estudios sobre la fonología del español del Caribe* (pp. 135–63). Caracas: Ediciones La Casa de Bello.
- Disterheft, Dorothy (1980). *The Syntactic Development of the Infinitive in IE*. Columbus: Slavica.
- Dixon, R. M. W. (1997). *The Rise and Fall of Languages*. Cambridge: Cambridge University Press.
- Dobson, Eric J. (1968). *English Pronunciation 1500–1700*. Oxford: Clarendon Press.
- Dobson, Henry Austin (1875). The paradox of time (a variation on Ronsard). *Good Words*, January. [Repr. in his *Complete Poetical Works*, ed. Alban Dobson (p. 116). London: Humphrey Milford, Oxford University Press, 1923.]
- Dobzhansky, Theodosius Grigorievich (1937). *Genetics and the Origin of Species*. New York: Columbia University Press. [Rev. 2nd edn, 1941. Rev. 3rd and last edn, 1951. Repr. 1982.]
- (1970). *Genetics of the Evolutionary Process*. New York: Columbia University Press.
- Doerfer, Gerhard (1973). *Lautgesetz und Zufall: Betrachtungen zum Omnikomparatismus*. Innsbruck: Institut für vergleichende Sprachwissenschaft der Universität Innsbruck. (Innsbrucker Beiträge zur Sprachwissenschaft, 10.)
- Donovan, Stephen K. and Paul, Christopher R. C. (eds) (1998). *The Adequacy of the Fossil Record*. Chichester: John Wiley.
- Dorian, Nancy C. (ed.) (1989). *Investigating Obsolescence: Studies in Language Contraction and Death*. Cambridge: Cambridge University Press.

- (1993). Internally and externally motivated change in language contact settings: doubts about dichotomy. In Charles Jones 1993 (pp. 131–55).
- Dörner, Dietrich (1977). Superzeichen und kognitive Prozesse. In Roland Posner and Hans-Peter Reineke (eds), *Zeichenprozesse: Semiotische Forschung in den Einzelwissenschaften* (pp. 73–82). Wiesbaden: Athenaion. (Schwerpunkte Linguistik und Kommunikationswissenschaft 14.)
- Dorsey, James Owen (1890). *The Čegihā Language*. Washington, DC: Government Printing Office. (Contributions to North American Ethnology VI.)
- Dorsey, James Owen and Swanton, John R. (1912). *A Dictionary of the Biloxi and Ofo Languages, Accompanied with Thirty-One Biloxi Texts and Numerous Biloxi Phrases*. Washington, DC: Government Printing Office. (Bureau of American Ethnology Bulletin 47.)
- Downes, William (1994). History and linguistics. In Asher and Simpson 1994 (vol. 3, pp. 1578–81).
- (1998). *Language and Society*. 2nd edn. Cambridge: Cambridge University Press. [1st edn, London: Fontana.]
- Doyle, Sir Arthur Conan (1902). *Adventures of Sherlock Holmes*. New York: Harper and Brothers.
- Dresher, B. Elan (1999). Charting the learning path: cues to parameter setting. *Linguistic Inquiry* 30(1), 27–67.
- Dresher, B. Elan and Kaye, Jonathan D. (1990). A computational learning model for metrical phonology. *Cognition* 34(2), 137–95.
- Dressler, Wolfgang U. (1972). *Allegroregeln rechtfertigen Lentoregeln*. Innsbruck: Institut für vergleichende Sprachwissenschaft, Universität Innsbruck. (Innsbrucker Beiträge zur Sprachwissenschaft, 9.)
- (1977). Elements of a polycentric theory of word formation. *Wiener linguistische Gazette* 15, 13–32.
- (1985a). Typological aspects of natural morphology. *Wiener linguistische Gazette* 36, 3–26. [Rev. in *Acta Linguistica Hungarica* 35 (1987), 51–70.]
- (1985b). *Morphonology: The Dynamics of Derivation*. Ann Arbor: Karoma.
- (1985c). On the predictiveness of natural morphology. *Journal of Linguistics* 21, 321–37.
- (1988a). Zur Bedeutung der Sprachtypologie in der Natürlichen Morphologie. In Jörn Albrecht, Harald Thun, and Jens Ludtke (eds), *Energieia und Ergon, Studia in honorem Eugenio Coseriu* (vol. 3, pp. 199–209). Tübingen: Narr.
- (1988b). Preferences versus strict universals in morphology: word based rules. In Hammond and Noonan 1988 (pp. 143–54).
- (1991). The sociolinguistic and patholinguistic attrition of Breton phonology, morphology, and morphonology. In Seliger and Vago 1991 (pp. 99–112).
- (1995a). Wealth and poverty of functional analyses, with special reference to functional deficiencies. In S. Miller and J. Mey (eds), *Form and Function in Language* (pp. 11–39). Odense: Odense University Press.
- (1995b). Wege des morphologischen Wandels und der Entstehung morphologischer Regeln. In Norbert Boretzky, Wolfgang U. Dressler, Janez Orešnik, Carmen Terzan, and Wolfgang Ullrich Wurzel (eds), *Natürlichkeitstheorie und Sprachwandel* (pp. 93–109). Bochum: Brockmeyer.
- (1996). A functionalist semiotic model of morphology. In Singh 1996 (pp. 67–83).
- (1997a). “Scenario” as a concept for the functional explanation of language change. In J. Gvozdanović (ed.), *Language Change and Functional Explanations* (pp. 109–42). Berlin: Mouton de Gruyter.

- (1997b). On productivity and potentiality in inflectional morphology. CLASNET Working Papers 7, 3–22.
- (1999). On a semiotic theory of preferences in language. In Shapiro and Haley 1999 (pp. 389–415).
- Dressler, Wolfgang U. and Acson, Veneeta (1985). On the diachrony of subtractive operations: evidence of semiotically based models of natural phonology and natural morphology from Northern and Anatolian Greek dialects. In Jacek Fisiak (ed.), *ICHL 6* (pp. 105–27). Amsterdam: John Benjamins.
- Dressler, Wolfgang U. and Merlini Barbaresi, Lavinia (1994). *Morphopragmatics*. Berlin: Mouton de Gruyter.
- Dressler, Wolfgang U., Mayerthaler, Willi, Panagl, Oswald, and Wurzel, Wolfgang U. (1987). *Leitmotifs in Natural Morphology*. Amsterdam: John Benjamins.
- Dryer, Matthew (1992). The Greenbergian word order correlations. *Language* 68(1), 81–138.
- Du Bois, John W. (1985). Competing motivations. In Haiman 1985b (pp. 343–65).
- Dummett, Michael (1964). Bringing about the past. *Philosophical Review* 73, 338–59. [Repr. in Gale 1967 (pp. 252–74) and in Le Poidevin and MacBeath 1993 (pp. 117–34).]
- Dunkel, George (1981). Typology versus reconstruction. In Yoël Arbeitman and Alan Bomhard (eds), *Bono homini donum: Essays in Historical Linguistics in Honor of J. Alexander Kerns* (pp. 559–69). Amsterdam: John Benjamins.
- Dupuis, F. (1989). *L'expression du sujet dans les subordinées en ancien français*. Ph.D. dissertation, Université de Montréal.
- Durand, M. (1955). Du rôle de l'auditeur dans la formation des sons du langage. *Journal de Psychologie Normale et Pathologique* 52, 347–55.
- Durie, Mark (1996). Early Germanic umlaut and variable rules. In Durie and Ross 1996 (pp. 112–34).
- Durie, Mark and Ross, Malcolm (eds) (1996). *The Comparative Method Reviewed: Regularity and Irregularity in Language Change*. New York and Oxford: Oxford University Press.
- Dyen, Isidore (ed.) (1973). *Lexicostatistics in Genetic Linguistics: Proceedings of the Yale Conference, Yale University, April 3–4, 1971*. The Hague: Mouton.
- Eames, C. and Eames, R. (1977). *Powers of Ten: A Flipbook*. New York: Freeman. [Repr. 1982.]
- Earman, John (1974). An attempt to add a little direction to “the problem of the direction of time.” *Philosophy of Science* 41, 15–47.
- (1995). Recent work on time travel. In Savitt 1995 (pp. 268–310).
- Ebeling, Carl L. (1960). *Linguistic Units*. The Hague: Mouton de Gruyter.
- Ebert, Karen H. (1991). Vom Verbum dicendi zur Konjunktion: Ein Kapitel universaler Grammatikentwicklung. In Bisang and Rinderknecht 1991 (pp. 77–95).
- Ebert, Robert P. (1978). *Historische Syntax des Deutschen*. Stuttgart: Sammlung Metzler.
- Eckert, Penelope (1988). Adolescent social structure and the spread of linguistic change. *Language in Society* 17, 183–207.
- (1989). The whole woman: sex and gender differences in variation. *Language Variation and Change* 1(3), 245–67.
- (1996). (ay) goes to the city: exploring the expressive use of variation. In Guy et al. 1996 (pp. 47–69).
- Eco, Umberto (1983). *The Name of the Rose*. New York: Harcourt Brace Jovanovich. [Italian original, 1980.]
- Eddington, Arthur S. (1928). *The Nature of the Physical World*. Cambridge: Cambridge University Press.

- Edkins, J. (1864). *A Grammar of the Chinese Colloquial Language Commonly Called the Mandarin Dialect*. Shanghai: Presbyterian Mission Press.
- Edwards, A. M. (1995). Springing forward and falling back: traveling through time. *Contemporary Philosophy* 17, 12–24.
- Edwards, Paul (ed.) (1967). *The Encyclopedia of Philosophy, Volumes 1–8*. New York: Macmillan. [Repr., 1972. (8 volumes regrouped in 4 tomes.)]
- Ehala, Martin (1996). Self-organization and language change. *Diachronica* 13, 1–28.
- (1998). How a man changed a parameter value: the loss of SOV in Estonian subclauses. In Hogg and van Bergen 1998 (pp. 73–88).
- Ehring, D. (1987). Personal identity and time travel. *Philosophical Studies* 52, 427–33.
- Ehrlich, Robert (2001). *Nine Crazy Ideas in Science: A Few Might Even Be True*. Princeton, NJ: Princeton University Press.
- Einstein, Albert (1905). Zur Elektrodynamik bewegter Körper. *Annalen der Physik* (series 4) 17, 891–921. [Repr. in Lorentz et al. 1922 (pp. 26–50) and 1982 (pp. 35–65) in its 1923 trans. as “On the electrodynamics of moving bodies” by W. G. Perrett and G. B. Jeffery (repr. again 1952).]
- (1916). Die Grundlage der allgemeinen Relativitätstheorie. *Annalen der Physik* (series 4) 49, 769–822. [Repr. in Lorentz et al. 1922 (pp. 81–124) and 1982 (pp. 109–64) in its 1923 trans. as “The foundation of the General Theory of Relativity” by W. G. Perrett and G. B. Jeffery (repr. again 1952).]
- Eisenberg, Ann (2000). Bringing back voices from the 19th century. *New York Times* January 20, D13.
- Elcock, W. D. and Green, John N. (1975). *The Romance Languages*. London: Faber and Faber. [Revised edn of 1960 edn by Elcock alone.]
- Eldredge, Niles (1971). The allopatric model and phylogeny in Paleozoic invertebrates. *Evolution* 25, 157–67.
- (1985). *Time Frames: The Rethinking of Darwinian Evolution and the Theory of Punctuated Equilibria*. New York: Simon and Schuster.
- (1989). *Macroevolutionary Dynamics: Species, Niches, and Adaptive Peaks*. New York: McGraw-Hill.
- (1991). *The Miner’s Canary: Unraveling the Mysteries of Extinction*. New York City, NY: Prentice Hall Press, 1991. [Repr. Princeton, NJ: Princeton University Press, 1994. (Princeton Science Library.)]
- (1995). *Reinventing Darwin: The Great Debate at the High Table of Evolutionary Theory*. New York: John Wiley.
- (1999). *The Pattern of Evolution*. New York: Freeman. [Paperback, 2000.]
- Eldredge, Niles and Gould, Stephen Jay (1972). Punctuated equilibria: an alternative to phyletic gradualism. In Thomas Joseph Morton Schopf (ed.), *Models in Paleobiology* (pp. 82–115). San Francisco: Freeman, Cooper.
- Eliasson, Stig (1992). Cognition in phonological change. In G. Kellermann and M. Morrissey (eds), *Diachrony Within Synchrony: Language History and Cognition; . . . [A] Symposium at the University of Duisburg, . . . 1990* (pp. 283–308). Frankfurt: Peter Lang.
- (1995). Grammatical and lexical switching in Maori-English “grasshopper speech.” In *Papers from the Summer School on Code-Switching and Language Contact, 14–17 September, 1994* (pp. 45–57). Ljouwert/ Leeuwarden, Friesland: Fryske Academy.
- Ellegård, Alvar (1953). *The Auxiliary DO: The Establishment and Regulation of its Use in English*. Stockholm: Almqvist and Wiksell. (Gothenburg Studies in English, 2.)
- Elman, Jeffrey L. (1993). Learning and development in neural networks. *Cognition* 48(1), 71–99.

- Embleton, Sheila (1986). *Statistics in Historical Linguistics*. Bochum: Brockmeyer.
- (1991). Mathematical models of genetic comparison. In S. M. Lamb and E. D. Mitchell (eds), *Sprung from Some Common Source: Investigations into the Prehistory of Languages* (pp. 365–88). Stanford: Stanford University Press.
- Embleton, Sheila, Joseph, John E., and Niederehe, Hans-Josef (eds) (1999). *The Emergence of the Modern Language Sciences: Studies on the Transition from Historical-Comparative to Structural Linguistics in Honour of E. F. K. Koerner*. Philadelphia: John Benjamins.
- Emeneau, Murray B. (1956). India as a linguistic area. *Language* 32(1), 3–16. [Repr. in Dell Hymes (ed.), *Language in Culture and Society* (pp. 642–53), New York: Harper and Row, 1964.]
- Emerson, Ralph Waldo (1876). Quotation and originality. In *Letters and Social Aims*. Boston, MA: James R. Osgood (pp. 155–81). [Repr. in his *Complete Works. Volume 8: Letters and Social Aims*, ed. Edward Waldo Emerson. New York: AMS Press, 1968.]
- (1965). *Selected Writings*, ed. William H. Gilman. New York: New American Library. [Repr. with rev. and updated bibliography, 1983. (Signet Classics, CE 2404.) Also in *The Journal and Miscellaneous Notebooks*, vols 1–16, eds William H. Gilman et al. Cambridge, MA: Belknap Press of Harvard University Press, 1960–82.]
- Emonds, Joseph (1978). The verbal complex V'-V in French. *Linguistic Inquiry* 9(2), 151–75.
- Encrevé, Pierre (1983). La liaison sans enchaînement. *Actes de recherche, sciences sociales* 46, 39–66.
- (1988). *La liaison avec et sans enchaînement: phonologie tridimensionnelle et usages du français*. Paris: Seuil.
- Endler, John (1977). *Geographic Variation, Speciation, and Clines*. Princeton, NJ: Princeton University Press. (Monographs in Population Biology, 10.)
- Engelmann, G. F. and Wiley, Edward Orlando (1977). The place of ancestor–descendant relationships in phylogeny reconstruction. *Systematic Evolution* 26(1), 1–11.
- Enkvist, Nils Erik and Wårvik, Brita (1987). Old English *þa*, temporal chains, and narrative structure. In Anna Giacolone Ramat, Onofrio Carruba, and Giuliano Bernini (eds), *ICHL 7* (pp. 221–37). Amsterdam: John Benjamins. (CILT 48.)
- Epstein, Samuel David, Thráinsson, Hoskuldur, and Jan-Wouter Zwart, C. (1996). Introduction. In Werner Abraham, Samuel David Epstein, Höskuldur Thráinsson, and C. Jan-Wouter Zwart (eds), *Minimal Ideas: Syntactic Studies in the Minimalist Framework* (pp. 1–66). Amsterdam and Philadelphia: John Benjamins. (Linguistik Aktuell/Linguistics Today 12.)
- Ereshefsky, Marc (1992). *The Units of Evolution: Essays on the Nature of Species*. Cambridge, MA: MIT Press. (Bradford Books.)
- Erickson, Gregory M. (1994). *Quakes, Eruptions, and Other Geologic Cataclysms*. New York City, NY: Facts on File. (Changing Earth.)
- (1999). Breathing life into *Tyrannosaurus rex*. *Scientific American* 281(3), 42–9.
- Erman, Britt and Kotsinas, Ulla-Britt (1993). Pragmaticalization: the case of *ba'* and *you know*. *Studier i modern språketenskap*. Acta Universitatis Stockholmiensis, new series 10, 76–93.
- Ernst, Thomas B. (1984). *Towards an Integrated Theory of Adverb Position in English*. Bloomington, IN: Indiana University Linguistics Club.
- Erwin, Douglas H. and Anstey, Robert L. (1995a). Introduction. In Erwin and Anstey 1995c (pp. 1–8).
- (1995b). Speciation in the fossil record. In Erwin and Anstey 1995c (pp. 11–38).
- (eds) (1995c). *New Approaches to Speciation in the Fossil Record*. New York: Columbia University Press.

- Esper, Erwin A. (1973). *Analogy and Association in Linguistics and Psychology*. Athens, GA: University of Georgia Press.
- Everett, Hugh, III (1957). "Relative state" formulation of quantum mechanics. *Reviews of Modern Physics* 29 (July), 454–62.
- Faarlund, Jan Terje (1990). *Syntactic Change: Toward a Theory of Historical Syntax*. Berlin: Mouton de Gruyter. (TIL 50.)
- Fabb, Nigel (1998). Compounding. In Spencer and Zwicky 1998 (pp. 66–83).
- Fagan, Brian (1995). *Time Detectives: How Archeologists Use Technology to Recapture the Past*. New York: Simon and Schuster.
- (ed.) (1996). *Oxford Companion to Archaeology*. Oxford: Oxford University Press.
- Fasold, Ralph W. (1990). *The Sociolinguistics of Language*. Oxford: Blackwell.
- (Favre de) Vaugelas, Claude (Baron de Peroges) (1647). *Remarques sur la langue françoise: utiles à ceux qui veulent bien parler et bien écrire*. Paris: (Chez) La Veuve [de] Jean Camusat and [(chez)] Pierre le Petit, Imprimeur and Libraire ordinaire du Roy, 1647. [Facsimile edn by Jeanne Streicher repr. Paris: Librairie E. Droz, 1934.]
- Felber, Helmut and Budin, Gerhard (1989). *Terminologie in Theorie und Praxis*. Tübingen: Narr.
- Fenyvesi, Anna (1995). Language contact and language death in an immigrant language: the case of Hungarian. *University of Pittsburg Working Papers in Linguistics* 3, 1–117.
- Ferguson, Charles (1959). Diglossia. *Word* 15, 325–40.
- (1975). "Short A" in Philadelphia English. In M. E. Smith (ed.), *Studies in Linguistics: In Honor of George L. Trager* (pp. 250–74). The Hague: Mouton de Gruyter.
- Fernández-Armesto, Felipe (1995). *Millennium: A History of the Last Thousand Years*. New York: Scribner.
- Ferrara, K. W. (1997). Form and function of the discourse marker *anyway*: implications for discourse analysis. *Linguistics* 35, 343–78.
- Fertig, David (1996). Phonology, orthography, and the umlaut puzzle. In Rosina Lippi-Green and Joseph Salmons (eds), *Germanic Linguistics: Syntactic and Diachronic* (pp. 169–84). Amsterdam: John Benjamins.
- Festschrift Jacob Wackernagel zur Vollendung des 70. Lebensjahres*. Göttingen: Vandenhoeck and Ruprecht.
- Festschrift Karl Jaberg, zugeeignet zur Feier seines 60. Geburtstages und zur Vollendung des 60. Semesters seines akademischen Lehramtes, 24. April 1937*. *Zeitschrift für romanische Philologie* 57 (1937), 120–520. [Also issued separately, Halle: Niemeyer, 1937.]
- Feynman, Richard Phillips (1949). The theory of positrons. *Physical Review* 76, 749–59.
- Fidelholtz, James L. (1975). Word frequency and vowel reduction in English. *CLS* 11, no. 1, 200–13.
- Field, Fredric W. (1998). Borrowing and borrowability. Ph.D. dissertation, University of Southern California.
- Fikkert, Johanna P. M. (1994). On the acquisition of prosodic structure. Ph.D. dissertation, University of Leiden.
- (1995). Models of acquisition: how to acquire stress. In J. Beckman (ed.), *Proceedings of the North Eastern Linguistics Society* 25, vol. 2, pp. 27–42. Graduate Linguistics Students Association, University of Massachusetts, Amherst.
- Fillmore, C. and Kay, P. (forthcoming). *Construction Grammar*. Stanford University: CSLI.
- Fillmore, Charles, Kay, Paul, and O'Connor, Mary (1988). Regularity and idiomaticity in grammatical constructions: the case of *let alone*. *Language* 64(3), 501–38.
- Fillmore, Charles J., Kempler, Daniel, and Wang, William S.-Y. (eds) (1979). *Individual Differences in Language Ability and Language Behavior*. New York: Academic Press. (Perspectives in Neurolinguistics and Psycholinguistics.)

- Fischer, David Hackett (1970). *Historians' Fallacies: Toward a Logic of Historical Thought*. New York: Harper and Row.
- (1989). *Albion's Seed: Four British Folkways in America*. New York: Oxford University Press. (America: A Cultural History, 1.)
- (1994). *Paul Revere's Ride*. New York: Oxford University Press.
- Fischer, Olga C. M. (1997). On the status of grammaticalisation and the diachronic dimension in explanation. *Transactions of the Philological Society* 95(2), 149–87.
- Fischer, Olga C. M. and van der Leek, Frederike C. (1987). A “case” for the Old English impersonal. In Willem Koopman, Frederike van der Leek, Olga C. M. Fischer, and Roger Eaton (eds), *Explanation and Linguistic Change* (pp. 79–120). Amsterdam: John Benjamins. (CILT 45.)
- Fisher, John (1958). Social influences on the choice of a linguistic variant. *Word* 14, 47–56.
- Fisiak, Jacek (ed.) (1980). *Historical Morphology*. The Hague: Mouton de Gruyter.
- (ed.) (1985). *Historical Semantics, Historical Word Formation*. Berlin: Mouton de Gruyter.
- Fleischman, Suzanne (1982). *The Future in Thought and Language: Diachronic Evidence from Romance*. Cambridge: Cambridge University Press. (CSL 36.)
- Fleming, Harold C. (1987). Towards a definitive classification of the world's languages. Review of Merritt Ruhlen, *A Guide to the World's Languages*. *Diachronica* 4, 159–223.
- Fletcher, Paul and MacWhinney, Brian (eds) (1995). *The Handbook of Child Language*. Oxford: Blackwell. (Blackwell Handbooks in Linguistics, 2.)
- Flew, Antony G. N. (1988). Time travel and the paranormal. *Philosophy* 63, 266–88.
- Fliegelman, Jay (1993). *Declaring Independence: Jefferson, Natural Language, and the Culture of Performance*. Stanford: Stanford University Press.
- Flier, Michael S. (ed.) (1974). *Slavic Forum: Essays in Linguistics and Literature*. The Hague and Paris: Mouton. (Slavistic Printings and Reprintings, 277.)
- Flood, Raymond and Lockwood, Michael (eds) (1986). *The Nature of Time*. Oxford: Blackwell.
- Fodor, Istvan (1965). *The Rate of Linguistic Change: Limits of the Application of Mathematical Methods in Linguistics*. The Hague: Mouton. (Janua linguarum. Series minor, 43.)
- Fodor, Jerry A. (1983). *The Modularity of Mind*. Cambridge, MA: MIT Press.
- (1998). Unambiguous triggers. *Linguistic Inquiry* 29(1), 1–36.
- Foley, James (1977). *Foundations of Theoretical Phonology*. Cambridge: Cambridge University Press.
- Foley, William A. (1986). *The Papuan Languages of New Guinea*. Cambridge: Cambridge University Press.
- Foley, William A. and van Valin, Robert D. (1984). *Functional Syntax and Universal Grammar*. Cambridge: Cambridge University Press. (CSL 38.)
- Folger, Tim (2000). From here to eternity. *Discover* 21(12), 54–61.
- Fölsing, Albrecht (1997). *Albert Einstein*. New York: Penguin. [Trans. Ewald Osers from the German original, *Albert Einstein: Eine Biographie*, Frankfurt: Suhrkamp, 1993.]
- Fontaine, Carmen (1985). Application de méthodes quantitatives en diachronie: l'inversion du sujet en français. M.A. thesis, Université du Québec à Montréal.
- Fontana, Josep M. (1993). Phrase structure and the syntax of clitics in the history of Spanish. Ph.D. dissertation, University of Pennsylvania.
- Foolen, Ad (1995). Dutch modal particles: the relevance of grammaticalized elements. In Thomas F. Shannon and Johan P. Snapper (eds), *The Berkeley Conference on Dutch Linguistics 1993* (pp. 57–70). Lanham, MD: University Press of America.
- Fortescue, Michael (n.d.) Greater Beringia: The prehistory of a linguistic bottleneck. Manuscript.

- Fortescue, Michael, Jacobson, Steven, and Kaplan, Lawrence (eds) (1994). *Comparative Eskimo Dictionary with Aleut Cognates*. Fairbanks: Alaska Native Language Center.
- Fortson, Benjamin W. IV (1998). A new study of Hittite *-wa(r)*. *Journal of Cuneiform Studies* 50, 21–34.
- (2002). Textbook in historical linguistics. Manuscript. Cambridge, MA.
- Fowler, Carol A. and Housum, Jonathan (1987). Talkers' signaling of "new" and "old" words in speech and listeners' perception and use of the distinction. *Journal of Memory and Language* 26(5), 489–504.
- Fowler, Joy (1986). The social stratification of (r) in New York City department stores, 24 years after Labov. Master's thesis, New York University.
- Fox, Anthony (1995). *Linguistic Reconstruction: An Introduction to Theory and Method*. Oxford: Oxford University Press.
- Fox, Barbara (ed.) (1995). *Studies in Anaphora*. Amsterdam and Philadelphia: John Benjamins. (TSL 33.)
- Fox, Richard G. (ed.) (1991). *Recapturing Anthropology: Working in the Present*. Santa Fe, NM: School of American Research Press.
- Frajzyngier, Zygmunt (1987). From verb to anaphora. *Lingua* 72, 155–68.
- (1991). The *de dicto* domain in language. In Traugott and Heine 1991a (pp. 219–51).
- (1995). On sources of demonstratives and anaphors. In Fox 1995 (pp. 169–203).
- (1996). *Grammaticalization of the Complex Sentence: A Case Study in Chadic*. Amsterdam: John Benjamins.
- (1997). Grammaticalization of number: from demonstrative to nominal and verbal plural. *Linguistic Typology* 1, 193–242.
- Frajzyngier, Zygmunt and Curl, Traci S. (eds) (2000a). *Reflexives: Forms and Functions*. Amsterdam and Philadelphia: John Benjamins. (TSL 40.)
- (eds) (2000b). *Reciprocals: Forms and Functions*. Amsterdam and Philadelphia: John Benjamins. (Typological Studies in Language, 41.)
- Francis, W. Nelson and Kučera, Henry (1982). *Frequency Analysis of English Usage*. Boston: Houghton Mifflin.
- Fraser, Bruce (1988). Types of English discourse markers. *Acta Linguistica Hungarica* 38(1), 19–33.
- (1990). An approach to discourse markers. *Journal of Pragmatics* 14, 383–95.
- Fraser, Julius Thomas (ed.) (1966). *The Voices of Time: A Cooperative Survey of Man's Views of Time as Expressed by the Sciences and by the Humanities*. Amherst, MA: University of Massachusetts Press. [2nd edn, 1981.]
- Fraser, Julius T. and Lawrence, Nathaniel M. (eds) (1975). *The Study of Time II: Proceedings of the Second Conference of the International Society for the Study of Time, Lake Yamanaka – Japan*. New York: Springer.
- Frazer, Timothy (1983). Sound change and social structure in a rural community. *Language in Society* 12, 312–28.
- Freeman, Scott and Herron, Jon C. (2001). *Evolutionary Analysis*. 2nd edn. Upper Saddle River, NJ: Prentice Hall.
- Friedrich, Paul (1972). Structural implications of Russian pronominal usage. In John Gumperz and Dell Hymes (eds), *Directions in Sociolinguistics* (pp. 270–300). Oxford: Blackwell.
- Friedrich, W. (1901). Die Flexion des Hauptworts in den heutigen deutschen Mundarten, Schluss. *Zeitschrift für deutsche Philologie* 33, 45–85.
- Fries, Charles C. (1940). On the development of the structural use of word-order in Modern English. *Language* 16(3), 199–208.

- Frolov, Valery P. and Novikov, Igor Dmitrievich (1990). Physical effects in wormholes and time machines. *Physical Review D* 42, 1057–65.
- Fromkin, Victoria (1997). Some thoughts about the brain/mind/language interface. *Lingua* 100, 3–27.
- Fromkin, Victoria and Rodman, Robert (1993). *An Introduction to Language*. 5th edn. New York: Harcourt Brace Jovanovich.
- Fuller, Reginald (1993). Jesus Christ. In Metzger and Coogan 1993 (pp. 356–66).
- Futuyma, Douglas J. (1979). *Evolutionary Biology*. Sunderland, MA: Sinauer Associates. [2nd edn, 1986. 3rd edn, 1997. 4th edn, 1998.]
- (1992). History and evolutionary processes. In Matthew H. Nitecki and Doris V. Nitecki (eds), *History and Evolution* (pp. 103–30). Albany: SUNY Press.
- Gabelentz, Georg von der (1901). *Die Sprachwissenschaft: ihre Aufgaben, Methoden und bisherigen Ergebnisse*. 2nd edn. Leipzig: Weigel Nachfolger.
- Gaeta, Livio (1998). Some remarks on analogy, reanalysis and grammaticalization. In Ramat and Hopper 1998 (pp. 89–105).
- Gale, Richard M. (ed.) (1967). *The Philosophy of Time: A Collection of Essays*. Garden City, NY: Anchor Doubleday.
- (1968). *The Language of Time*. New York: Humanities Press. (International Library of Philosophy and Scientific Method.)
- Gamkrelidze, T'amaz Valerianovich and Ivanov, Vjacheslav Vsevolodovich (1972). Lingvističeskaja tipologija i rekonstrukcija sistemy indoevropskix smyčnyx. In S. B. Bernštejn et al. (eds), *Conference on Comparative-Historical Grammar of the Indo-European Languages* (pp. 15–18). Moscow: Akademija Nauk SSSR.
- (1973). Sprachtypologie und die Rekonstruktion der gemeinindogermanischen Verschlüsse. *Phonetica* 27, 150–6.
- (1984). *Indoevropskij jazyk i indoevropcy: Rekonstrukcija i istoriko-tipologičeskij analiz prajazyka i protokul' tury*. Tbilisi: Publishing House of Tbilisi State University. [Trans. Johanna Nichols as *Indo-European and the Indo-Europeans*, Berlin: Mouton de Gruyter, 1994.]
- Garey, Howard (1959). *Verte, grande, and longue*: three types of analogy in Old French. *Language* 35(4), 605–11.
- Garrett, Andrew (1991). Review article: Indo-European reconstruction and historical methodologies. *Language* 67(4), 790–804.
- Gass, S. and Madden, C. (eds) (1985). *Input in Second Language Acquisition*. Rowley, MA: Newbury House.
- Gates, Phelps (1976). On the chronology of the Attic Rückverwandlung. *Glotta* 54, 44–52.
- Gauchat, Louis (1905). L'unité phonétique dans le patois d'une commune. In *Aus romanischen Sprachen und Literaturen: Festschrift Heinrich Morf* (pp. 175–232). Halle: Niemeyer.
- Geach, Peter T. (1969). *God and the Soul*. New York: Schrocken Books. (Studies in Ethics and the Philosophy of Religion.)
- (1979). *Truth, Love, and Immortality*. London: Hutchinson.
- Geary, D. H. (1990). Patterns of evolutionary tempo and mode in the radiation of *Melanopsis* (Gastropoda: *Melanopsidae*). *Paleobiology* 16, 492–511.
- Geeraerts, Dirk (1983). Reclassifying semantic change. *Quaderni di semantica* 4(2), 217–40.
- (1986). Functional explanation in diachronic semantics. In Alain Bossuyt (ed.), *Functional Explanation in Linguistics* (pp. 67–93). Brussels: Éditions de l'Université de Bruxelles. (Belgian Journal of Linguistics, 1.)

- Geertz, Clifford (1973). *The Interpretation of Cultures: Selected Essays*. New York: Basic Books.
- Geis, Michael L. and Zwicky, Arnold M. (1971). On invited inferences. *Linguistic Inquiry* 11, 561–6.
- Genetti, Carol (1986). The development of subordinators from postpositions in Bodic languages. *BLS* 12, 387–400.
- (1991). From postposition to subordinator in Newari. In Traugott and Heine 1991b (pp. 227–55).
- Gensler, Orin D. (1993). A typological evaluation of Celtic/Hamito-Semitic syntactic parallels. Ph.D. dissertation, University of California, Berkeley.
- Gess, Randall (1996). Optimality theory in the historical phonology of French. Ph.D. dissertation, University of Washington.
- (1999). Rethinking the dating of Old French syllable-final consonant loss. *Diachronica* 16(2), 261–96.
- Ghiselin, M. (1974). *Metaphysics and the Origin of Species*. Albany, NY: SUNY Press.
- (1987). Species concepts, individuality, and objectivity. *Biology and Philosophy* 2, 127–43.
- (1989). Sex and the individuality of species: a reply to Mishler and Brandon. *Biology and Philosophy* 4, 73–6.
- Gibbon, Edward (1776). *The Rise and Fall of the Roman Empire*. London. [Repr. 1994.]
- Gibson, Helen (1999). See how they run: the dinosaurs once again stalk the earth. *Time Magazine* 154. 16 (October 18).
- Gibson, Edward and Wexler, Kenneth (1994). Triggers. *Linguistic Inquiry* 25(3), 407–54.
- Giddings, Luther Val, Kaneshiro, Kenneth Y., and Anderson, Wyatt W. (eds) (1989). *Genetics, Speciation, and the Founder Principle*. New York: Oxford University Press.
- Gilbert, Glenn (ed.) (2002). *Pidgin and Creole Linguistics in the 21st Century*. New York: Lang.
- Gili Gaya, S. (1921). La *r* simple en la pronunciación española. *Revista de filología española* 8, 271–8.
- Gili, Filippo Salvatore (1780–4). *Saggio di storia americana: o sia, storia naturale, civile e sacra de' regni, e delle provincie spagnuole di Terra-Ferma nell' America Meridionale descritta dall' abate F. S. Giliij*. 4 vols. Rome: Perego. [Trans. Antonio Tovar as *Ensayo de historia americana, 1782*, Caracas: Biblioteca de la Academia Nacional de la Historia, 1965. (Fuentes para la Historia Colonial de Venezuela, 71–3.)]
- Gilliéron, Jules (1912). *Études de géographie linguistique*. Paris: Honoré Champion, Libraire-Éditeur.
- Gimbutas, Marija (1970). Proto-Indo-European culture: the Kurgan culture during the fifth, fourth, and third millennia BC. In George Cardona, Henry Hoenigswald, and Alfred Senn (eds), *Indo-European and Indo-Europeans: Papers presented at the Third Indo-European Conference at the University of Pennsylvania* (pp. 155–97). Philadelphia: University of Pennsylvania Press.
- (1985). Primary and secondary homeland of the Indo-Europeans. *Journal of Indo-European Studies* 13, 185–202.
- Gingerich, Philip D. (1974). Stratigraphic record of Early Eocene *Hyopsodus* and the geometry of mammalian phylogeny. *Nature* 248: 107–9.
- (1976). Paleontology and phylogeny: patterns of evolution at the species level in Early Tertiary mammals. *American Journal of Science* 276, 1–28.
- Girard, Dennis and Larmouth, Donald (1993). Some applications of mathematical and statistical models in dialect geography. In Dennis R. Preston (ed.), *American Dialect Research* (pp. 107–31). Philadelphia: John Benjamins.

- Givón, Talmy (1971). Historical syntax and synchronic morphology: an archaeologist's field trip. *CLS* 7, no. 1, 394–415.
- (1975). Serial verbs and syntactic change: Niger-Congo. In Li 1975 (pp. 47–112).
- (1976). Topic, pronoun and grammatical agreement. In Li 1976 (pp. 149–88).
- (1977). The drift from VSO to SVO in Biblical Hebrew: the pragmatics of tense-aspect. In i 1977 (pp. 181–254.)
- (1979). *On Understanding Grammar*. New York: Academic Press.
- (1981). On the development of the numeral “one” as an indefinite marker. *Folia Linguistica Historica* 2(1), 35–53.
- (1990). *Syntax: A Functional Typological Introduction, volume 2*. Amsterdam: John Benjamins.
- (1991). Serial verbs and the mental reality of “event”: grammatical versus cognitive packaging. In Traugott and Heine 1991a (pp. 81–127).
- Glassie, Henry (1968). *Pattern in the Material Folk Culture of the Eastern United States*. Philadelphia: University of Pennsylvania Press. [2nd edn, 1971. 3rd edn, 1996.]
- Gleason, Henry (1961). *An Introduction to Descriptive Linguistics*. New York: Holt, Rinehart, and Winston.
- Goddard, Ives (1967). The Algonquian independent indicative. *National Museum of Canada Bulletin No. 214*, Ottawa: Queen's Printer, 66–106.
- (1973). Philological approaches to the study of North American Indian languages: documents and documentation. In Thomas A. Sebeok, ed., *Current Trends in Linguistics Vol. 10: Linguistics in North America (Pt. 1)* (pp. 727–45). The Hague: Mouton.
- (1975). Algonquian, Wiyot, and Yurok: proving a distant genetic relationship. In M. Dale Kinkade, Kenneth L. Hale, and Oswald Werner (eds), *Linguistics and Anthropology in Honor of C. F. Vogelin* (pp. 249–62). Lisse: Peter de Ridder Press.
- (1989). Stylistic dialects in Fox linguistic change. In Jacek Fisiak (ed.), *Historical Dialectology: Regional and Social* (pp. 193–209). Berlin: Mouton de Gruyter.
- (1991). Algonquian linguistic change and reconstruction. In Baldi 1991 (pp. 55–70).
- Gödel, Kurt (1949). An example of a new type of cosmological solution of Einstein's field equations of gravitation. *Reviews of Modern Physics* 21 (July), 447–50.
- Goldberg, Adele (1995). *Constructions: A Construction Grammar Approach to Argument Structure*. Chicago: University of Chicago Press.
- Goldin-Meadow, Susan and Mylander, Carolyn (1990). Beyond the input given: the child's role in the acquisition of language. *Language* 66(2), 323–55.
- Goldschmidt, Richard B. (1940). *The Material Basis of Evolution*. Seattle: University of Washington Press. [Repr. New Haven: Yale University Press, 1982.]
- Golla, Victor (ed.) (1984). The Sapir–Kroeber correspondence. *Survey of California and Other Indian Languages*, report 6. Berkeley: University of California Press.
- Golovko, Evgenij V. and Vakhtin, Nikolai B. (1990). Aleut in contact: the CIA enigma. *Acta Linguistica Hafniensia* 22, 97–125.
- Goodenough, Ward (1992). Gradual and quantum changes in the history of Chuukese (Trukese) phonology. *Oceanic Linguistics* 31(1), 93–114.
- Goodfriend, Glenn A. and Gould, Stephen Jay (1996). Paleontology and chronology of two evolutionary transitions by hybridization in the Bahamian land snail *Cerion*. *Science* 274, 1894–7.
- Goodheart, Adam (1999). Into the depths of history. *Preservation* 51(1), 36–45.
- Goodman, Morris (1970). Some questions on the classification of African languages. *International Journal of American Linguistics* 36(2), 117–22.
- Goodman, Nelson (1967). Uniformity and simplicity. In Albritton 1967a (pp. 93–9).

- Goosens, Louis (1992). *Cunnam, conne(n), can*: the development of a radial category. In Kellermann and Morrissey 1992 (pp. 377–94).
- Gordon, Arthur E. (1975). *The Inscribed Fibula Praenestina: Problems of Authenticity*. Berkeley: University of California Press. (University of California Publications, Classical Studies, 16.)
- Gordon, Matthew (1995). The phonological composition of personal pronouns: implications for generic hypotheses. *BLS* 21, 117–28.
- Gordon, Matthew and Heath, Jeffrey (1998). Sex, sound symbolism, and sociolinguistics. *Current Anthropology* 39(4), 421–49.
- Gott, J. (1991). Closed timelike curves produced by pairs of moving cosmic strings: exact solutions. *Physical Review Letters* 656 (March 4), 1126–9.
- Gott, J. Richard (2000). Will we travel back (or forward) in time? *Time* (April 10), 68.
- Gould, Stephen Jay (1965). Is uniformitarianism necessary? *American Journal of Science* 263(3), 223–8.
- (1975). Catastrophes and steady state earth. *Natural History* 84(2), 14–18. [Rev. as “Uniformity and catastrophe” in Gould 1977 (pp. 147–52).]
- (1977). *Ever Since Darwin: Reflections in Natural History*. New York: W. W. Norton. [Repr. in paperback 1979.]
- (1980). *The Panda’s Thumb: More Essays in Natural History*. New York: Norton.
- (1982). The meaning of punctuated equilibrium and its role in validating a hierarchical approach to macroevolution. In Roger Milkman (ed.), *Perspectives on Evolution* (pp. 83–104). Sunderland, MA: Sinauer Associates.
- (1984). Towards the vindication of punctuational change. In Berggren and Van Couvering 1984 (pp. 9–34).
- (1985). The paradox of the first tier: an agenda for paleobiology. *Paleobiology* 11, 2–12.
- (1987). *Time’s Arrow, Time’s Cycle: Myth and Metaphor in the Discovery of Geological Time*. Cambridge, MA: Harvard University Press.
- (1989). Punctuated equilibrium in fact and theory. In Somit and Peterson 1989 (pp. 54–84).
- (1990). Speciation and sorting as the source of evolutionary trends, or “things are seldom what they seem.” In K. J. McNamara (ed.), *Evolutionary Trends* (pp. 3–27). London: Belhaven.
- (1991). *Bully for Brontosaurus: Reflections in Natural History*. New York: Norton.
- (1993). Unenchanted evening. In *Eight Little Piggies: Reflections in Natural History* (pp. 23–40). London: Jonathan Cape.
- (1997). Darwinian fundamentalism. *New York Review of Books* 44(11) (June 26), 47–52.
- (1998). *Leonardo’s Mountain of Clams and the Diet of Worms: Essays on Natural History*. New York: Harmony Books.
- (2000). *The Lying Stones of Marrakech: Penultimate Reflections in Natural History*. New York: Harmony Books.
- (2002). *The Structure of Evolutionary Theory*. Cambridge, MA: Belknap Press of Harvard University Press.
- Gould, Stephen Jay and Eldredge, Niles (1977). Punctuated equilibria: the tempo and mode of evolution considered. *Paleobiology* 3, 115–51.
- (1993). Punctuated equilibrium comes of age. *Nature* 366, 223–7.
- Goyvaerts, D. L. (1975). *Present-Day Historical and Comparative Linguistics: An Introductory Guide to Theory and Method; Part I: General Background*. Ghent: Story-Scientia.
- (1981). *Aspecten van semantische taalverandering*. Ghent: Story-Scientia.

- Grace, G. W. (1981). Indirect inheritance and the aberrant Melanesian languages. In J. Hollyman and A. K. Pawley (eds), *Studies in Pacific Languages and Cultures in Honour of Bruce Biggs* (pp. 255–68). Auckland: Linguistic Society of New Zealand.
- (1985). Oceanic subgrouping: retrospect and suspect. In A. K. Pawley and L. Carrington (eds), *Austronesian Linguistics at the 15th Pacific Science Congress* (pp. 1–18). Canberra: Pacific Linguistics C-88.
- (1990). The “aberrant” versus “exemplary” Melanesian languages. In Philip Baldi (ed.), *Linguistic Change and Reconstruction Methodology* (pp. 155–73). Berlin: Mouton de Gruyter.
- Grafton, Anthony (1997). *The Footnote: A Curious History*. Cambridge, MA: Harvard University Press.
- Grant, Michael (1990). *The Visible Past: Greek and Roman History from Archaeology, 1960–1990*. New York: Charles Scribner’s Sons.
- Grant, Peter R. and Grant, B. Rosemary (1999). The founding of a new population of Darwin’s finches. *Evolution* 48, 1273–85.
- Gräslund, Bo (1987). *The Birth of Prehistoric Chronology: Dating Methods and Dating Systems in Nineteenth-Century Scandinavian Archaeology*. Cambridge: Cambridge University Press.
- Greenberg, Joseph H. (1957). *Essays in Linguistics*. Chicago: University of Chicago Press.
- (1960). An Afro-Asiatic pattern of gender and number agreement. *Journal of the American Oriental Society* 80, 317–21.
- (1963). Languages of Africa. *Publications of the Indiana University Research Center in Anthropology, Folklore, and Linguistics* 25. Bloomington: Indiana University Press.
- (1966). Some universals of language with particular reference to the order of meaningful elements. In Joseph H. Greenberg (ed.), *Universals of Language* (pp. 73–113). Cambridge, MA: MIT Press. [2nd edn; 1st edn 1963.]
- (1978). How does a language acquire gender markers? In Greenberg et al. 1978 (pp. 47–82).
- (1987). *Language in the Americas*. Stanford: Stanford University Press.
- (1991). The last stage of grammatical elements: contractive and expansive desemantization. In Traugott and Heine 1991a (pp. 301–14).
- Greenberg, Joseph H., Ferguson, Charles A. and Moravcsik, Edith (eds) (1978). *Universals of Human Language. Volume 3: Word Structure*. Stanford: Stanford University Press.
- Greene, Brian (1999). *The Elegant Universe: Superstrings, Hidden Dimensions, and the Quest for the Ultimate Theory*. New York: Norton.
- Greenlee, M. and Ohala, John J. (1980). Phonetically motivated parallels between child phonology and historical sound change. *Language Sciences* 2, 283–308.
- Grégoire, Antoine (1947). *L’apprentissage du langage, II: La troisième année et les années suivantes*. Liège: Faculté de Philosophie et Lettres, Université de Liège. (Bibliothèque de la Faculté de Philosophie et Lettres de l’Université de Liège, 106.) [Repr. 1968.]
- Greither, Aloys (1962). *Wolfgang Amadé Mozart in Selbstzeugnissen und Bilddokumenten*. Reinbek: Rowohlt Taschenbuch Verlag GmbH. (Rowohlts Monographien, 77.) [Repr. 1974.]
- Grimm, Jacob (1819). *Deutsche Grammatik*, vol. 1. 2nd edn. Göttingen: Dieterich.
- Grosjean, François and Soares, Carlos (1986). Processing mixed languages: some preliminary findings. In Jyotsna Vaid (ed.), *Language Processing in Bilinguals: Psycholinguistic and Neuropsychological Perspectives* (pp. 145–79). Hillsdale, NJ: Erlbaum.
- Guarducci, Margherita (1984). *La cosiddetta fibula prenestina: elementi nuovi*. Rome: Accademia nazionale dei Lincei. (Atti della Accademia nazionale dei Lincei, 0391–8149; Memorie, Classe di scienze morali, storiche e filologiche, ser. 8, vol. 28, fasc. 2.)

- Gudschinsky, Sarah (1956). The ABC's of lexicostatistics. *Word* 12, 175–210.
- Güldemann, Tom (2001). Quotative constructions in African languages: a synchronic and diachronic survey. Habilitationsschrift, University of Leipzig.
- Gumperz, John J. and Wilson, Robert (1971). Convergence and creolization: a case from the Indo-Aryan/Dravidian border in India. In Dell Hymes (ed.), *Pidginization and Creolization of Languages* (pp. 151–67). Cambridge: Cambridge University Press.
- Guthrie, Malcolm (1967–71). *Comparative Bantu: An Introduction to the Comparative Linguistics and Prehistory of the Bantu Languages*. 4 vols. Farnborough: Gregg.
- Guy, Gregory R. (1980). Variation in the group and the individual. In Labov 1980a (pp. 1–36).
- (1981). Linguistic variation in Brazilian Portuguese: aspects of the phonology, syntax, and language history. Ph.D. dissertation, University of Pennsylvania.
- (1988). Language and social class. In Frederick J. Newmeyer (ed.), *Linguistics: The Cambridge survey, IV: Language: The Socio-Cultural Context* (pp. 37–63). New York: Cambridge University Press.
- (1990). The sociolinguistic types of language change. *Diachronica* 7(1), 47–67.
- (1996). Form and function in linguistic variation. In Gregory R. Guy, Crawford Feagin, Deborah Schiffrin, and John Baugh (eds), *Towards a Social Science of Language: Papers in Honor of William Labov. Volume 1: Variation and Change in Language and Society* (pp. 221–52). Amsterdam: John Benjamins.
- (1997a). Violable is variable: Optimality Theory and linguistic variation. *Language Variation and Change* 9, 333–47.
- (1997b). Competence, performance, and the generative grammar of variation. In Hinskens et al. 1997 (pp. 125–43).
- Guy, Gregory R. and Boberg, Charles (1997). The obligatory contour principle and sociolinguistic variation. *Language Variation and Change* 9, 149–64.
- Guy, Gregory and Boyd, Sally (1990). The development of a morphological class. *Language Variation and Change* 2, 1–18.
- Guy, Gregory R., Feagin, Crawford, Schiffrin, Deborah, and Baugh, John (eds) (1996). *Towards a Social Science of Language: Papers in Honour of William Labov. Volumes 1–2*. Amsterdam and Philadelphia: John Benjamins.
- Guy, Gregory R., Horvath, Barbara, Vonwiller, Julia, Daisley, Elaine, and Rogers, Inge (1986). An intonational change in progress in Australian English. *Language in Society* 15(1), 23–52.
- Guy, Jacques (1994). Re: 5.1159 Comparative method yet again. Posting 1168, message 3, to LINGUIST (22 October 1994).
- Haas, Mary R. (1958). Algonkian-Ritwan: the end of a controversy. *International Journal of American Linguistics* 24, 159–73.
- (1969). *The Prehistory of Languages*. The Hague: Mouton.
- Haerberli, E. (2000). Adjuncts and the syntax of subjects in Old and Middle English. In S. Pintzuk, G. Tsoulas, and A. Warner (eds), *Diachronic Syntax: Models and Mechanisms* (pp. 109–31). Oxford: Oxford University Press.
- Haegeman, L. and van Riemsdijk, Henk (1986). Verb projection raising, scope, and the typology of verb movement rules. *Linguistic Inquiry* 17, 417–66.
- Haeri, Niloofar (1996). “Why do women do this?” Sex and gender difference in speech. In Guy et al. 1996 (pp. 101–14).
- (1997). *The Sociolinguistic Market of Cairo: Gender, Class and Education*. London and New York: Kegan Paul International.
- Haft, Adele J., White, Jane G., and White, Robert J. (1987). *The Key to The Name of the Rose*. Harrington Park, NJ: Ampersand.

- Hagège, Claude (1993). *The Language Builder: An Essay on the Human Signature in Morphogenesis*. CILT 94. Amsterdam: John Benjamins.
- Hägerstrand, Torsten (1952). *The Propagation of Innovation Waves*. Lund: Lund Studies in Geography, no. 44.
- Haggett, P. (1979). *Geography: A Modern Synthesis*. 3rd edn. New York: Harper and Row.
- Haiman, John (1985a). *Natural Syntax: Iconicity and Erosion*. Cambridge: Cambridge University Press.
- (ed.) (1985b). *Iconicity in Syntax: Proceedings of a Symposium on Iconicity in Syntax, Stanford, June 24–6, 1983*. Amsterdam: John Benjamins. (TSL 6.)
- (1994). Ritualization and the development of language. In Pagliuca 1994 (pp. 3–28).
- Haiman, John and Thompson, Sandra A. (eds) (1988). *Clause Combining in Grammar and Discourse*. Amsterdam: John Benjamins. (TSL 18.)
- Haldane, John Burdon Sanderson (1932). *The Causes of Evolution*. London: Longmans, Green. [Paperback edn, Ithaca, NY: Cornell University Press, 1966. Ed. Egbert G. Leigh, Jr. and repr., Princeton, NJ: Princeton University Press, 1990. Repr. 1993.]
- Hale, Kenneth (1973). Deep–surface canonical disparities in relation to analogy and change: an Australian example. In Thomas Sebeok (ed.), *Current Trends in Linguistics, 11: Diachronic, Areal, and Typological Linguistics* (pp. 401–58). The Hague: Mouton.
- Hale, Mark (1987). Notes on Wackernagel's Law in the language of the *Rigveda*. In Calvert Watkins (ed.), *Studies in Memory of Warren Cowgill* (pp. 38–50). Berlin: Mouton de Gruyter.
- (1997). Theory and method in historical linguistics. Manuscript.
- (1998). Minimalist diachronic syntax. *Syntax* 1, 1–17.
- Hale, Mark, Kissock, Madelyn, and Reiss, Charles (1998). Output–output correspondence in Optimality theory. *WCCFL* 16, 1–14.
- Hale, Mark and Reiss, Charles (1998). Formal and empirical arguments concerning phonological acquisition. *Linguistic Inquiry* 29, 656–83.
- Hale, William G. and Buck, Carl D. (1966). *A Latin Grammar*. University, AL: University of Alabama Press.
- Haley, Michael C. (1988). *The Semeiosis of Poetic Metaphor*. Bloomington: Indiana University Press.
- (1999). Metaphor, mind, and space: what Peirce can offer Lakoff. In Shapiro and Haley 1999.
- Hallam, Anthony (1998). Lyell's views on organic progression, evolution, and extinction. In Blundell and Scott 1998 (pp. 133–6).
- Halldórsson, B., Torfason, J., Tómasson, S., and Thorsson, Ö. (eds) (1985–6). *Íslendinga sögur*. Reykjavik: Svart a hvítu.
- Halle, Morris (1962). Phonology in generative grammar. *Word* 18, 54–72.
- Halle, M. and Smith, C. P. (1952). Distinctive features of voiceless stop consonants. *Quarterly Progress Report, Research Laboratory of Electronics, MIT* 27, 48–53.
- Halliday, Michael A. K. (1961). Categories of the theory of grammar. *Word* 17(3), 241–92.
- Hammond, Michael and Noonan, Michael (eds) (1988). *Theoretical Morphology: Approaches in Modern Linguistics*. San Diego: Academic Press.
- Hamp, Eric P. (1976). On Eskimo–Aleut and Luoravetlan. In Eric Hamp (ed.), *Papers on Eskimo and Aleut Linguistics* (pp. 81–92). Chicago: Chicago Linguistic Society.
- Hamp, Eric P., Householder, Fred W., and Austerlitz, Robert (eds) (1966). *Readings in Linguistics, 2*. Chicago: University of Chicago Press.
- Hankamer, Jorge (1977). Multiple analyses. In Li 1977 (pp. 583–607).

- Hanson, Kristin (1987). On subjectivity and the history of epistemic expressions in English. *CLS* 23, no. 1, 133–47.
- Harms, Robert T. (1990). Synchronic rules and diachronic “laws”: the Saussurean dichotomy reaffirmed. In Polomé 1990 (pp. 313–23).
- Harnad, Stevan R., Steklis, Horst D., and Lancaster, Jane (eds) (1976). *Origins and Evolution of Language and Speech*. New York: New York Academy of Sciences. (Annals of the New York Academy of Sciences, 280.)
- Har(r)ington, John (1618). Treason. In *The Most Elegant and Witty Epigrams of Sir John Harrington*. . . . London: John Budge. [Repr. (facsimile) Menston: Scholar Press, 1970 and (non-facsimile) in *The Letters and Epigrams of Sir John Harrington*, ed. N. E. McClure, New York: Octagon Books, 1997.]
- Harris, Alice (1981). *Georgian Syntax: A Study in Relational Grammar*. Cambridge: Cambridge University Press.
- (1984). Inversion as a rule of universal grammar: Georgian evidence. In David M. Perlmutter and Carl G. Rosen (eds), *Studies in Relational Grammar 2* (pp. 259–91). Chicago: University of Chicago Press.
- (1985). *Diachronic Syntax: The Kartvelian Case*. New York: Academic Press. (Syntax and Semantics, 18.)
- (1991). On the history of the Kartvelian languages. In Alice Harris (ed.), *The Indigenous Languages of the Caucasus: Kartvelian* (pp. 7–83). Delmar, NY: Caravan Press.
- (1994). Ergative-to-accusative shift in agreement: Tabassaran. In Howard I. Aronson (ed.), *Linguistic Studies in the Non-Slavic Languages of the Commonwealth of Independent States and the Baltic Republics (NSI 7)* (pp. 113–31). Chicago: Chicago Linguistic Society.
- (1995). On the history of relative clauses in Georgian. In Howard I. Aronson (ed.), *Papers from the Fourth Conference on the Non-Slavic languages of the USSR* (pp. 130–42). (*Folia Slavica*.)
- Harris, Alice and Campbell, Lyle (1995). *Historical Syntax in Cross-Linguistic Perspective*. Cambridge: Cambridge University Press.
- (1996). Syntactic doublets and language change. Presented at the Annual Meeting of the Linguistic Society of America. Manuscript.
- Harris, Roy (trans.) (1983). *Course in General Linguistics*, by Ferdinand de Saussure. La Salle, IL: Open Court Classics.
- Harrison, G. A., Tanner, J. M., Pillbeam, D. R., and Baker, P. T. (1988). *Human Biology: An Introduction to Human Evolution, Variation, Growth, and Adaptation*. Oxford: Oxford University Press.
- Harrison, S. P. (1977). Some problems in the history of Mokilese morpho-syntax. Ph.D. dissertation, University of Hawaii.
- (1982). Proto-Oceanic *aki(ni) and the Proto-Oceanic periphrastic causative. In S. A. Wurm and L. Carrington (eds), *Papers from the 3rd International Conference on Austronesian Linguistics* (pp. 179–230). Canberra: Pacific Linguistics C-74.
- (1986). On the nature of subgrouping arguments. In P. Geraghty, L. Carrington, and S. A. Wurm (eds), *FOCAL II: Papers from the 4th International Conference on Austronesian Linguistics* (pp. 13–21). Canberra: Pacific Linguistics C-94.
- Harvey, Paul H. and Pagel, Mark D. (1991). *The Comparative Method in Evolutionary Biology*. Oxford: Oxford University Press. (Oxford Series in Ecology and Evolution, 1.)
- Hashimoto, Mantaroo J. (1981). Review of Wang 1977. *Language* 57(1), 183–91.
- Haspelmath, Martin (1990). The grammaticization of passive morphology. *Studies in Language* 14(1), 25–72.

- (1991). From purposive to infinitive: a universal path of grammaticization. *Folia Linguistica Historica* X(1/2), 287–310.
- (1997a). *From Space to Time: Temporal Adverbs in the World's Languages*. Munich and Newcastle: Lincom Europa.
- (1997b). *Indefinite Pronouns*. Oxford: Clarendon Press.
- (1998). Does grammaticalization need reanalysis? *Studies in Language* 22(2), 315–51.
- (1999). Why is grammaticalization irreversible? *Linguistics* 37(6), 1043–68.
- Hasselmo, Nils (1970). Code-switching and modes of speaking. In Glenn Gilbert (ed.), *Texas Studies in Bilingualism* (pp. 179–209). Berlin: Mouton de Gruyter.
- Haugen, Einar (1950). The analysis of linguistic borrowing. *Language* 26, 210–31.
- Haukioja, Timo (1993). Hyperlinguistic individuals and the relation between language and cognition: a methodological note. *Cognitive Linguistics* 4, 395–405.
- Hauser, Marc D. (1996). *The Evolution of Communication*. Cambridge, MA: MIT Press. (Bradford Books.) [Paperback edn 1997. Repr. 1998.]
- Hawking, Stephen W. (1992). The chronology protection conjecture. *Physical Review D* 46, 603–11.
- (1996). *The Illustrated Brief History of Time*. New York: Bantam Books. [1st edn, as *A Brief History of Time*, 1988.]
- (2000). *The Theory of Everything: The Origin and Fate of the Universe*. Beverly Hills, CA: New Millennium Press. [First pub. as *Cambridge Lectures: Life Works*. West Hollywood, CA: Dove Books/Audio.]
- (2001). *The Universe in a Nutshell*. New York: Bantam Books. (Book Laboratory Books.)
- Hawking, Stephen W. and Ellis, George F. R. (1973). *The Large Scale Structure of Space-Time*. Cambridge: Cambridge University Press.
- Hawkins, John A. (1979). Implicational universals as predictors of word order change. *Language* 55(3), 618–48.
- (1983). *Word Order Universals*. New York: Academic Press.
- (1988a). Explaining language universals. In Hawkins 1988b (pp. 3–28).
- (ed.) (1988b). *Explaining Language Universals*. Oxford: Blackwell.
- (1990). A parsing theory of word order universals. *Linguistic Inquiry* 21, 223–62.
- (1994). *A Performance Theory of Order and Constituency*. Cambridge: Cambridge University Press.
- Hawkins, John A. and Cutler, Anne (1988). Psycholinguistic factors in morphological asymmetry. In Hawkins 1988b (pp. 280–317).
- Hawkins, John A. and Gilligan, Gary (1988). Prefixing and suffixing universals in relation to basic word order. In John A. Hawkins and Heather K. Holmback (eds), *Papers in Universal Grammar: Generative and Typological Approaches* (pp. 219–59). Special issue of *Lingua* 74(2/3).
- Headrick, M. P. and Gott, J. Richard (1994). (2 + 1)-dimensional spacetimes containing closed timelike curves. *Physical Review D* 50, 7244–59.
- Healey, Richard A. (ed.) (1981). *Reduction, Time, and Reality*. Cambridge: Cambridge University Press.
- Heaney, Seamus (2000). *Beowulf: A New Verse Translation*. New York: Farrar, Straus and Giroux.
- Heath, Jeffrey (1978). *Linguistic diffusion in Arnhem Land*. Canberra: Australian Institute of Aboriginal Studies. (Australian Aboriginal Studies: Research and Regional Studies, 13.)
- (1989). *From Code-Switching to Borrowing: A Case Study of Moroccan Arabic*. London and New York: Kegan Paul International.

- (1998). Hermit crabs: formal renewal of morphology by phonologically mediated affix substitution. *Language* 74(4), 728–59.
- Heine, Bernd (1976). *A Typology of African Languages (Based on the Order of Meaningful Elements)*. Berlin: Reimer. (Kölner Beiträge zur Afrikanistik, 4.)
- (1989). Adpositions in African languages. *Linguistique Africaine* 2, 77–127.
- (1992). Grammaticalization chains. *Studies in Languages* 16(2), 335–68.
- (1993). *Auxiliaries: Cognitive Forces and Grammaticalization*. New York and London: Oxford University Press.
- (1994a). Areal influence on grammaticalization. In Pütz 1994 (pp. 55–68).
- (1994b). On the nature of semantic change in grammaticalization. In Negri and Poli 1994 (pp. 11–28).
- (1994c). Grammaticalization as an explanatory parameter. In Pagliuca 1994 (pp. 255–87).
- (1994d). Some principles of grammaticalization. Paper presented at the Berkeley–Cologne–Stanford Symposium on Grammaticalization, Stanford and Berkeley, April 2–3.
- (1995). Conceptual grammaticalization and prediction. In Taylor and MacLaury 1995 (pp. 119–35).
- (1997a). *Possession: Cognitive Sources, Forces, and Grammaticalization*. Cambridge: Cambridge University Press.
- (1997b). *Cognitive Foundations of Grammar*. Oxford: Oxford University Press.
- (2000). Polysemy involving reflexive and reciprocal markers in African languages. In Frajzyngier and Curl 2000b (pp. 1–29).
- Heine, Bernd and Kilian-Hatz, Christa (1994). Polysemy in African languages: an example from Baka (Cameroon). In Thomas Geider and Raimund Kastenholtz (eds), *Sprachen und Sprachzeugnisse in Afrika: eine Sammlung philologischer Beiträge Wilhelm J. G. Mühligh zum 60. Geburtstag zugeeignet*. Cologne: Rüdiger Köppe Verlag.
- Heine, Bernd and Kuteva, Tania (2002). *World Lexicon of Grammaticalization*. Cambridge: Cambridge University Press.
- Heine, Bernd and Reh, Mechthild (1982). Patterns of grammaticalization in African languages. Cologne: University of Cologne, Institut für Sprachwissenschaft. (*Arbeiten des Kölner Universalien-Projekts*, 47.)
- (1984). *Grammaticalization and Reanalysis in African Languages*. Hamburg: Helmut Buske Verlag.
- Heine, Bernd, Claudi, Ulrike, and Hünemeyer, Friederike (1991). *Grammaticalization: A Conceptual Framework*. Chicago and London: University of Chicago Press.
- Heine, Bernd, Güldemann, Tom, Kilian-Hatz, Christa, Lessau, Donald A., Roberg, Heinz, Schladt, Mathias, and Stolz, Thomas (1993). Conceptual shift: a lexicon of grammaticalization processes in African languages. *Afrikanistische Arbeitspapiere* [Cologne], 34/35, 1–322.
- Helman, David H. (ed.) (1988). *Analogical Reasoning: Perspectives of Artificial Intelligence, Cognitive Science, and Philosophy*. Dordrecht, etc.: Kluwer Academic.
- Hendrickson, Robert L. (ed.) (1998). *QPB Encyclopedia of Word and Phrase Origins*. New York: Facts on File.
- Hennig, Willi (1969). *Die Stammesgeschichte der Insekten*, ed. Senckenbergische naturforschende Gesellschaft zu Frankfurt am Main. Frankfurt: Verlag von [Dr.] Waldemar Kramer (Senckenberg-Bücher, 49). [Transl. and ed. Adrian Charles Pont (with Dieter Schlee, Michael Achtelig . . . et al. [authors of “revisionary notes”]) as *Insect Phylogeny*, Chichester: John Wiley (Wiley-Interscience Publications), 1981.]

- Herbert, Robert K. (1990a). The relative markedness of click sounds: evidence from language change, acquisition, and avoidance. *Anthropological Linguistics* 32(1–2), 120–38.
- (1990b). The sociohistory of clicks in Southern Bantu. *Anthropological Linguistics* 32(3–4), 295–315.
- Herder, Johann Gottfried (1772). *Abhandlung über den Ursprung der Sprache*. Berlin: Christian Friedrich Voss.
- (1877–1913). *Sämtliche Werke, Band 1–33*, ed. Bernhard Suphan. Berlin: Weidmann. [Originally pub. c.1767.]
- Hermann, M. Eduard (1929). Lautveränderungen in der Individualsprache einer Mundart. *Nachrichten der Gesellschaft der Wissenschaften zu Göttingen, Philosophisch-historische Klasse* 9, 195–214.
- (1931). *Lautgesetz und Analogie*. Göttingen: Gesellschaft der Wissenschaften.
- Hernández, José (1872). *The Gaucho Martín Fierro (1872)*. [Facsimile of 1st edn, with transl. Frank G. Carrino, Alberto J. Carlos, and Norman Mangouni, Delmar, NY: Scholars' Facsimiles and Reprints, 1974.]
- Herring, Susan C. (1991). The grammaticalization of rhetorical questions in Tamil. In Traugott and Heine 1991a (pp. 17–35).
- Herzog, Eugen (1904). *Streitfragen der romanischen Philologie, 1. Bändchen: die Lautgesetzfrage: zur französischen Lautgeschichte*. Halle an der Saale: Niemeyer.
- Hesse, Mary B. (1966). *Models and Analogies in Science*. Notre Dame: University of Notre Dame Press.
- Hewitt, J. N. B. (1903). Iroquoian cosmology, first part, Mohawk version. *Bureau of American Ethnology, Annual Report* 21, 255–338.
- Hibiya, Junko (1988). A quantitative study of Tokyo Japanese. Ph.D. dissertation, University of Pennsylvania.
- (1996). Denasalization of the velar nasal in Tokyo Japanese. In Guy et al. 1996 (pp. 161–73).
- Hill, Archibald A. (1940). Early loss of *r* before dentals. *Publications of the Modern Language Association* 55, 308–59.
- Hillman, Gordon C. (1989). Late Palaeolithic plant foods from Wadi Kubaniya in Upper Egypt: dietary diversity, infant weaning, and seasonality in a riverine environment. In David R. Harris and Gordon C. Hillman (eds), *Farming and Foraging: The Evolution of Plant Exploitation* (pp. 207–39). London: Unwin Hyman.
- Himmelmann, Nikolaus (1997). *Deiktikon, Artikel, Nominalphrase: Zur Emergenz syntaktischer Struktur*. Tübingen: Niemeyer.
- Hinskens, Frans, van Hout, Roeland, and Wetzels, W. Leo (eds) (1997). *Variation, Change, and Phonological Theory*. Amsterdam: John Benjamins. (Current Issues in Linguistic Theory, 146.)
- Hirschbühler, Paul and Labelle, Marie (1994). Changes in verb position in French negative infinitival clauses. *Language Variation and Change* 6, 149–78.
- Hirt, Hermann (1931). *Handbuch des Urgermanischen, Teil 1*. Heidelberg: Carl Winters Universitätsverlag.
- Hock, Hans Henrich (1976). Review of Anttila 1972. *Language* 52(1), 202–20.
- (1985). Regular metathesis. *Linguistics* 23(4), 529–46.
- (1986). *Principles of Historical Linguistics*. Berlin: Mouton de Gruyter. [2nd edn, 1991.]
- (1987). Regular contact dissimilation. In George Cardona and Norman Zide (eds), *Festschrift for Henry Hoenigswald* (pp. 143–53). Tübingen: Narr.

- (1991). Initial strengthening. In Wolfgang U. Dressler, Hans C. Luschützky, Oskar E. Pfeiffer, and John R. Rennison (eds), *Phonologica 1988: Proceedings of the 6th International Phonology Meeting* (pp. 101–10). Cambridge: Cambridge University Press.
- (1993a). Swallow tales: chance and the “world etymology” MALIQ’A “swallow, throat.” *CLS* 29, 215–38.
- (1993b). “Glottalic” notes. Presentation given at Workshop on Historical Linguistics, LSA Institute, Columbus, OH. Manuscript, University of Illinois.
- Hock, Hans Henrich and Joseph, Brian D. (1996). *Language History, Language Change, and Language Relationship: An Introduction to Historical and Comparative Linguistics*. Berlin: Mouton de Gruyter.
- Hockett, Charles (1958). *A Course in Modern Linguistics*. New York: Macmillan.
- (1985). Knowledge of the past. In A. Makkai and A. Melby (eds), *Linguistics and Philosophy: Essays in Honor of Rulon S. Wells* (pp. 317–41). Amsterdam: John Benjamins.
- Hodge, Carleton T. (1970). The linguistic cycle. *Language Sciences* 13, 1–7.
- (1972). Sources of historical linguistic evidence. In M. Estelle Smith (ed.), *Studies in Linguistics in Honor of George L. Trager* (pp. 87–99). The Hague: Mouton. (*Janua Linguarum, Series Major* 52.)
- Hoehner, Harold W. (1993). Herodian dynasty. In Metzger and Coogan 1993 (pp. 280–4).
- Hoeningwald, Henry M. (1950). The principal step in comparative grammar. *Language* 26, 357–64.
- (1960). *Language Change and Linguistic Reconstruction*. Chicago: University of Chicago Press.
- (1964). Graduality, sporadicity, and the minor sound change processes. *Phonetica* 11, 202–15. [Repr. in Baldi and Werth 1978 (pp. 160–71).]
- (1966). Are there universals of linguistic change? In Joseph H. Greenberg (ed.), *Universals of Grammar* (2nd edn) (pp. 30–52). Cambridge, MA: MIT Press.
- (1978). The annus mirabilis 1876 and posterity. *Transactions of the Philological Society* 17–35.
- (1999). Come and gone: evanescent intermediate stages, Latin vowel syncope, and other matters. In Heiner Eichner and Hans Christian Luschützky (eds), *Compositiones Indogermanicae in Memoriam Jochem Schindler* (pp. 153–61). Prague: Enigma.
- Hoeningwald, Henry M. and Wiener, Linda F. (1987). *Biological Metaphor and Cladistic Classification: An Interdisciplinary Approach*. Philadelphia: University of Pennsylvania Press.
- Höfding, Harald (1924). *Der Begriff der Analogie*. Leipzig: Reisland. [Also Darmstadt: Wissenschaftliche Buchgesellschaft, 1967.]
- Hoffman, Antoni (1989). *Arguments on Evolution: A Paleontologist’s Perspective*. New York: Oxford University Press.
- Hogg, Richard M. (1980). Analogy as a source of morphological complexity. *Folia Linguistica Historica* 1(2), 277–84.
- (1997). Using the future to predict the past: Old English dialectology in the light of Middle English place names. In Jacek Fisiak (ed.), *Studies in Middle English Language* (pp. 207–20). Berlin: Mouton de Gruyter.
- Hogg, Richard M. and van Bergen, Linda (eds) (1998). *Historical Linguistics 1995. Volume 2: Germanic Linguistics*. Amsterdam and Philadelphia: John Benjamins. (CILT, 162.)
- Hohepa, Patrick W. (1967). *A Profile Generative Grammar of Maori*. Baltimore, MD: Waverly Press by Indiana University, Bloomington.

- Holland, Rupert Sargent (1927). *Historic Railroads*. Philadelphia: Macrae Smith.
- Holman, Eugene (1985). On the semasiologization of phonological rules: the semiotic evolution of Finnish consonant gradation. *ICHL* 6, 281–90.
- Holmes, Janet and Bell, Allen (1992). On shear markets and sharing sheep: the merger of EAR and AIR in New Zealand English. *Language Variation and Change* 4(3), 251–74.
- Holt, Alfred Hubbard (1936). *Phrase and Origins*. New York: Thomas Y. Crowell. [Rev. and enlarged edn as *Phrase and Word Origins: Being a Study of Familiar Expressions*. New York: Dover Publications, 1961. Repr. 1996.]
- Holt, D. Eric (1996). From Latin to Hispano-Romance: a constraint-based approach to vowel nasalization, sonorant simplification, and the Late Spoken Latin open mid vowels. *CLS* 32, 111–23.
- (1997). The role of the listener in the historical phonology of Spanish and Portuguese: an Optimality-Theoretic account. Ph.D. dissertation, Georgetown University.
- Holyoak, Keith J. and Thagard, Paul (1995). *Mental Leaps: Analogy in Creative Thought*. Cambridge, MA, and London: MIT Press.
- Hombert, Jean-Marie, Ohala, John J., and Ewan, William G. (1979). Phonetic explanations for the development of tones. *Language* 55(1), 37–58.
- Honderich, Ted (ed.) (1995). *The Oxford Companion to Philosophy*. Oxford: Oxford University Press.
- Hooper, Joan Bybee (1976a). Word frequency in lexical diffusion and the source of morphophonological change. In Christie 1976 (pp. 96–105).
- (1976b). *An Introduction to Natural Generative Phonology*. New York: Academic Press.
- (1979). Substantive principles in natural generative phonology. In Daniel A. Dinnsen (ed.), *Current Approaches to Phonological Theory* (pp. 106–25). Bloomington: Indiana University Press.
- Hooykaas, Reijer (1959). *Natural Law and Divine Miracle: A Historical-Critical Study of the Principle of Uniformity in Geology, Biology, and Theology*. Leiden: Brill. [Pub. as *The Principle of Uniformity in Geology, Biology, and Theology: Natural Law and Divine Miracle*. Leiden: Brill, 1963. Transl. René Pavans as *Continuité et discontinuité en géologie et biologie*. Paris: Editions du Seuil, 1970.]
- (1970). Catastrophism in geology: its scientific character in relation to actualism and uniformitarianism. *Mededelingen der Koninklijke Akademie van Wetenschappen, Afdeling Letterkunde* (nieuwe reeks) 33(7), 271–316. [Also issued separately, Amsterdam: North-Holland.]
- Hopkins, G. W. (1980). Ravel, Joseph Maurice. In Stanley Sadie (ed.), *The New Grove Dictionary of Music and Musicians*. Vol. 15: *Playford–Riedt* (pp. 609–21). London: Macmillan.
- Hopper, Paul J. (1973). Glottalized and murmured occlusives in Indo-European. *Glossa* 7, 141–66.
- (1987). Emergent grammar. *BLS* 13, 139–57.
- (1991). On some principles of grammaticization. In Traugott and Heine 1991a (pp. 17–35).
- (1994). Phonogenesis. In Pagliuca 1994 (pp. 29–45).
- Hopper, Paul J. and Thompson, Sandra A. (1984). Transitivity in grammar and discourse. *Language* 56, 251–99.
- Hopper, Paul J. and Traugott, Elizabeth C. (1993). *Grammaticalization*. Cambridge: Cambridge University Press.

- Horn, L. R. (1984). Toward a new taxonomy for pragmatic inference: Q-based and R-based implicature. In Deborah Schiffrin (ed.), *Meaning, Form, and Use in Context: Linguistic Applications* (pp. 11–42). Washington: Georgetown University Press. (GURT, 84.)
- Horne Tooke, John (1857). *Epea Pteroenta, or the Diversions of Purley*. 2 vols. London.
- Horner, John R. and Gorman, James (1988). *Digging Dinosaurs*. New York: Workman.
- Horwich, Paul (1987). *Asymmetries in Time*. Cambridge, MA: MIT Press.
- (1995). Closed causal chains. In Savitt 1995 (pp. 259–67).
- Houk, Rose and Collier, Michael (1994). *White Sands National Monument*. Tucson: South-west Parks and Monuments Association.
- Householder, Fred, Kazazis, Kostas, and Koutsoudas, Andreas (1964). *Reference Grammar of Literary Dhimotiki*. Bloomington: Indiana University Research Center in Anthropology, Folklore, and Linguistics; The Hague: Mouton.
- Howard, Daniel J. and Berlocher, Stewart H. (eds) (1998). *Endless Forms: Species and Speciation*. New York: Oxford University Press.
- Hróarsdóttir, D. (1996). The decline of OV word order in the Icelandic VP. *Working Papers in Scandinavian Syntax* 57, 92–141.
- (2000). Interacting movements in the history of Icelandic. In S. Pintzuk, G. Tsoulas, and A. Warner (eds), *Diachronic Syntax: Models and Mechanisms* (pp. 296–321). Oxford: Oxford University Press.
- Hrozný, Friedrich [Bedřich] (1917). *Die Sprache der Hethither*. Leipzig: J. C. Hinrichs. (Boghazköi-Studien, 1–2.)
- (1919). *Hethitische Keilschrifttexte aus Boghazköi in Umschrift, mit Übersetzung und Kommentar*. Leipzig: J. C. Hinrichs.
- Hubbert, Marion King (1967). Critique of the Principle of Uniformity. In Albritton 1967a (pp. 33–50). [Repr. in Albritton 1975 (pp. 225–55).]
- Hubel, D. (1978). Vision and the brain. *Bulletin of the American Academy of Arts and Sciences* 31, 7–28.
- Hubel, D. and Wiesel, T. (1962). Receptive fields, binocular interaction, and functional architecture in the cat's visual cortex. *Journal of Physiology* 160, 106–54.
- Huber, Magnus (1996). The grammaticalization of aspect markers in Ghanaian Pidgin English. In Baker and Sycia 1996 (pp. 53–70).
- Hudson, Kenneth (1971). *A Guide to the Industrial Archaeology of Europe*. Cranbury, NJ: Associated University Presses.
- Huggett, Richard (1989). *Cataclysms and Earth History*. Oxford: Clarendon Press.
- Hughes, Geoffrey (1992). Social factors in the formulation of a typology of semantic change. In Kellermann and Morrissey 1992 (pp. 85–105).
- Hulk, A. and van Kemenade, A. (1997). Negation as a reflex of clause structure. In D. Forget, P. Hirschbühler, F. Martineau, and M.-L. Rivero (eds), *Negation and Polarity* (pp. 183–208). Amsterdam: John Benjamins.
- Hull, David Lee (1976). Are species really individuals? *Systematic Zoology* 25(2), 174–91.
- (1978). A matter of individuality. *Philosophy of Science* 45, 335–60.
- (1980). Individuality and selection. *Annual Review of Ecology and Systematics* 11, 311–22.
- (1981). The units of evolution: a metaphysical essay. In Juul Jensen and Rom Harré (eds), *The Philosophy of Evolution* (pp. 23–44). Brighton: Harvester Press. (Harvester Studies in Philosophy, 26.) [Repr. in Robert N. Brandon and Richard R. Burian (eds), *Genes, Organisms, Populations: Controversies over the Units of Selection* (pp. 142–60). Cambridge, MA: MIT Press, 1984.]

- (1988). Interactors versus vehicles. In Henry C. Plotkin (ed.), *The Role of Behavior in Evolution* (pp. 19–50). Cambridge, MA: MIT Press. (Bradford Books.)
- (1999). On the plurality of species: questioning the party line. In Wilson 1990 (pp. 23–48).
- Hull, David Lee and Ruse, Michael (eds) (1998). *The Philosophy of Biology*. Oxford: Oxford University Press. (Oxford Readings in Philosophy.)
- Hume, David (1748). *An Enquiry Concerning Human Understanding and Concerning the Principles of Morals*. [Posthumous edn, 1777. Repr. with intro and index by L. A. Selby-Bigge, 1893. 3rd edn, rev. P. H. Nidditch, Oxford: Clarendon Press, 1975.]
- (1776). *The Letters of David Hume*. 2 vols. Ed. John Y. T. Greig. [Repr. Oxford: Clarendon Press, 1932, 1969.]
- Hunter, R. S. T., Arnold, A. J., and Parker, W. C. (1988). Evolution and homeomorphy in the development of the Paleocene *Planorotalites pseudomenardii* and the Miocene *Globorotalia (Globorotalia) maragritae* lineages. *Micropaleontology* 34, 181–92.
- Hurford, James R. (1989). Biological evolution of the Saussurean sign as a component of the language acquisition device. In Nerlich 1989 (pp. 187–222).
- Hurford, James R., Studdert-Kennedy, Michael, and Knight, Chris (eds) (1998). *Approaches to the Evolution of Language: Social and Cognitive Bases*. Cambridge: Cambridge University Press.
- Hutcheson, James (1973). Remarks on the nature of complete consonant assimilation. *CLS* 9, no. 1.
- Hutton, James (1788). Theory of the Earth. *Transactions of the Royal Society of Edinburgh* 1, 209–305.
- (1795). *Theory of the Earth, with Proofs and Illustrations*. Edinburgh: William Creech. [Repr. in Weinheim: H. R. Engelmann (J. Cramer); New York: Hafner, 1960. (Historiae naturalis classica, I, 1–2.)]
- Huxley, Leonard (ed.) (1900). *Life and Letters of Thomas Henry Huxley [1825–1895], Volumes 1–2*. London: Macmillan. [Also New York: D. Appleton, 1901.]
- Huxley, Thomas Henry (1859). My dear Darwin. (Letter to Charles Darwin, November 23, 1859, the day before the publication of *On the Origin of Species*.) [Repr. in Huxley 1900 (vol. 1, p. 189).]
- Hyams, Nina (1986). *Language Acquisition and the Theory of Parameters*. Dordrecht: Reidel.
- Hyman, Larry M. (1976). Phonologization. In A. Juilland, Andrew M. Devine, and Laurence D. Stephens (eds), *Linguistic Studies Offered to Joseph Greenberg, Volume 2* (pp. 407–18). Saratoga, CA: Anma Libri.
- Hymes, Dell (1960). Lexicostatistics so far. *Current Anthropology* 1, 3–44.
- (1974a). *Foundations in Sociolinguistics: An Ethnographic Approach*. Philadelphia: University of Pennsylvania Press.
- (ed.) (1974b). *Studies in the History of Linguistics: Traditions and Paradigms*. Bloomington: Indiana University Press. (Indiana University Studies in the History and Theory of Linguistics.)
- Hymes, Dell Hathaway and Fought, John G. (1981). *American Structuralism*. The Hague: Mouton. (Janua linguarum, series maior, 102.) [Main body of text originally in Thomas Albert Sebeok et al. (eds), *Current Trends in Linguistics. Vol. 13, Part 2* (pp. 903–1178). The Hague: Mouton, 1975.]
- Illich-Svitych, Vladislav M. (1989a). A Nostratic word list: reconstructions by Vladislav Illich-Svitych, translated and arranged by Jim Parkinson. In Vitaly Shevoroshkin (ed.), *Explorations in Language Macrofamilies: Materials from the First International Interdisciplinary Symposium on Language and Prehistory* (pp. 128–62). Bochum: Brockmeyer.

- (1989b). The early reconstructions of Nostratic by Vladislav M. Illich-Svitych, translated and arranged by Mark Kaiser. In Vitaly Shevoroshkin (ed.), *Reconstructing Languages and Cultures: Materials from the First International Interdisciplinary Symposium on Language and Prehistory* (pp. 131–74). Bochum: Brockmeyer.
- (1990). The Nostratic reconstructions of Vladislav Illich-Svitych, translated and arranged by Mark Kaiser. In Vitaly Shevoroshkin (ed.), *Proto-Languages and Proto-Cultures: Materials from the First International Interdisciplinary Symposium on Language and Prehistory* (pp. 138–67). Bochum: Brockmeyer.
- Inge, M. Thomas (ed.) (1988). *Naming the Rose: Essays on Eco's The Name of the Rose*. Jackson and London: University Press of Mississippi.
- Inkelas, Sharon (1994). The consequences of optimization for underspecification. Manuscript, University of California, Berkeley.
- Inkelas, Sharon and Cho, Young-Mee (1993). Inalterability as prespecification. *Language* 69(3), 529–74.
- Isačenko, Alexander V. (1974). On “have” and “be” languages: a typological sketch. In Flier 1974 (pp. 43–77).
- Itkonen, Esa (1983). *Causality in Linguistic Theory: A Critical Investigation into the Philosophical and Methodological Foundations of “Non-Autonomous” Linguistics*. London and Canberra: Croom Helm. [Repr. Bloomington: Indiana University Press, 1984.]
- (1991). *Universal History of Linguistics: India, China, Arabia, Europe*. Amsterdam and Philadelphia: John Benjamins.
- (1994). Iconicity, analogy, and universal grammar. *Journal of Pragmatics* 22, 37–53.
- (1999). Grammaticalization: abduction, analogy, and rational explanation. In Shapiro and Haley 1999.
- Itkonen, Esa and Haukioja, Jussi (1996). A rehabilitation of analogy in syntax (and elsewhere). In András Kertész (ed.), *Metalinguistik im Wandel: Die “kognitive Wende” in Wissenschaftstheorie und Linguistik* (pp. 131–77). Frankfurt: Lang.
- Iverson, Gregory K., Davis, Garry W., and Salmons, Joseph C. (1994). Blocking environments in Old High German umlaut. *Folia Linguistica Historica* 15(1–2), 131–48.
- Jaberg, Karl (1908). *Spracheographie: Beitrag zum Verständnis des “Atlas linguistique de la France.”* Aarau: H. R. Sauerländer.
- Jaberg, Karl and Jud, Jakob (1928). *Der Sprachatlas als Forschungsinstrument: Kritische Grundlegung und Einführung in den Sprach- und Sachatlas Italiens und der Südschweiz*. Halle: Niemeyer.
- (1928–40ff). *Sprach- und Sachatlas Italiens und der Südschweiz*. 8 vols. Zofingen: Ringier.
- Jablonski, Nina G. and Aiello, Leslie C. (eds) (2000). *The Origin and Diversification of Language*. Berkeley: University of California Press.
- Jackendoff, Ray S. (1972). *Semantic Interpretation in Generative Grammar*. Cambridge, MA: MIT Press.
- (1975). Morphological and syntactic regularities in the lexicon. *Language* 51, 639–71.
- Jackson, Frederick Henry (1983). The internal and external relationships of the Trukic languages of Micronesia. Ph.D. dissertation, Department of Linguistics, University of Hawaii.
- Jackson, Jeremy B. C. and Cheetham, Alan H. (1990). Evolutionary significance of morphospecies: a test with Cheilostome *Bryozoa*. *Science* 248, 579–83.
- (1994). Phylogeny reconstruction and the tempo of speciation in Cheilostome *Bryozoa*. *Paleobiology* 20, 407–23.

- (1999). Tempo and mode of speciation in the sea. *Trends in Ecology and Evolution* 14, 72–7.
- Jacobi, W. A. T. (1843). *Beitrage zur deutschen Grammatik*. Berlin: T. Trautwein.
- Jacobs, Andreas and Jucker, Andreas H. (1995). The historical perspective in pragmatics. In Jucker 1995 (pp. 3–33).
- Jacobs, Melville (1954). The areal spread of sound patterns in the languages north of California. In *Papers from the Symposium on American Indian languages* (pp. 46–56). Berkeley: University of California Press.
- Jacobsen, William H., Jr. (1980). Inclusive/exclusive: a diffused pronominal category in native western North America. In J. Kreiman and A. E. Ojeda (eds), *Papers from the Parasession on Pronouns and Anaphora* (pp. 204–27). Chicago: CLS.
- Jacobson, Steven (1982). Types of partial nominalization in Central Yup'ik Eskimo. *Etude/Inuit/Studies* 6, 2.
- (1984). *Yup'ik Eskimo Dictionary*. Fairbanks: Alaska Native Language Center, University of Alaska.
- Jaeger, Jeri (1980). Testing the psychological reality of phonemes. *Language and Speech* 23, 233–53.
- (1984). Assessing the psychological status of the Vowel Shift Rule. *Journal of Psycholinguistic Research* 13, 13–36.
- Jaeger, Jeri and Ohala, John (1984). On the structure of phonetic categories. *BLS* 10, 15–26.
- Jahr, E. (ed.) (1999). *Language Change: Advances in Historical Sociolinguistics*. Berlin: Mouton.
- Jakobson, Roman (1929). Remarques sur l'évolution phonologique du russe comparée à celle des autres langues slaves. *Travaux du Cercle linguistique de Prague*, 2. [Repr. in *Selected Writings, Volume 1* (pp. 7–116). The Hague: Mouton, 1962.]
- (1931). Prinzipien der historischen Phonologie. *Travaux du Cercle Linguistique de Prague* 4, 247–67.
- (1958). Typological studies and their contribution to historical comparative linguistics. *Proceedings of the VIII International Congress of Linguists, Oslo* (pp. 17–25). [Repr. in *Selected Writings, Volume 1* (pp. 523–32), The Hague: Mouton, 1962. Repr. in Keiler 1972 (pp. 299–305).]
- (1960). Why “mama” and “papa”? In Bernard Kaplan and Seymour Wapner (eds), *Perspectives in Psychological Theory* (pp. 21–9). New York: International Universities Press. [Repr. in *Selected Writings, Volume 1* (pp. 538–45), The Hague: Mouton, 1962.]
- (1981). My favorite topics. Acceptance speech for the Premio Internazionale per la Filologia e la Linguistica. [Repr. in *Selected Writings, Volume 7* (pp. 371–6), The Hague: Mouton, 1985.]
- Jakobson, Roman, Fant, Gunnar, and Halle, Morris (1952). *Preliminaries to Speech Analysis*. Cambridge, MA: MIT Press.
- Jakobson, Roman Osipovich and Pomorska Jakobson, Krystyna (1988). Le facteur temporel dans le langage et la littérature. [First pub. in R. Jakobson and K. Pomorska [Jakobson], *Dialogues*, Paris: Flammarion, 1980. Transl. Christian Hubert as “The Time Factor in Language and Literature,” in R. O. Jakobson and K. Pomorska [Jakobson], *Dialogues* (pp. 56–78), Cambridge, MA: MIT Press, 1983. Ultimately based on the taped Russian original (source of the authors' French transl.) later pub. as “Vremennoi faktor v jazyke i literature,” no. 7 of “*Besedy (Dialogues)*,” in R. O. Jakobson, ed. Stephen Rudy, *Selected Writings, 8 (Completion Volume 1): Major Works, 1976–1980* (pp. 483–500), The Hague: Mouton, 1988.]

- James, E., Mahut, C., and Latkiewicz, G. (1989). The investigation of an apparently new intonation pattern in Toronto English. *Information Communication* 10, 11–17.
- James, William (1886). The perception of time. *Journal of Speculative Philosophy* 20, 374–407. [Rev. repr. in his *The Principles of Psychology*. Vol. 1 (pp. 605–42). New York: Henry Holt, 1890. (American Science Series, Advanced Course.) Repr. 1918, 1927. Also in his *The Essential Writings*, ed. Bruce W. Wilshire (pp. 119–27). New York: Harper and Row. (Harper Torchbooks, TB 1616.)]
- Jameson, David L. (ed.) (1977). *Genetics of Speciation*. Stroudsburg, PA: Dowden, Hutchinson, and Ross. (Benchmark Books, Benchmark Papers in Genetics, 9.)
- Janda, Laura A. (1996). *Back from the Brink: A Study of How Relic Forms in Languages Serve as Source Material for Analogical Extension*. Munich and Newcastle: Lincom Europa.
- Janda, Richard D. (1982). Of formal identity and rule-(un)collapsibility: on lost and found generalizations in morphology. *WCCFL* 1, 179–97.
- (1984). Why morphological metathesis rules are rare: on the possibility of historical explanation in linguistics. In Claudia Brugman and Monica Macaulay (eds), *BLS* 10 (pp. 87–103).
- (1987). On the motivation for an evolutionary typology of sound-structural rules. Ph.D. dissertation, University of California at Los Angeles.
- (1989). And, there are innovations both in correlative and non-correlative conjunctions: on syntactic change in Modern English. Paper presented at the 9th International Conference on Historical Linguistics, Rutgers University, New Brunswick, New Jersey, August 14–18, 1989.
- (1990). Language change always takes place in the present . . . [.] governed by constraints on synchronic grammars: against so-called diachronic processes and explanatory mechanisms of change that no speaker could possess. Paper presented at the 19th Linguistics Symposium, University of Wisconsin, Milwaukee, April 20–2, 1990 ([On] Explanation in Historical Linguistics).
- (1991). Frequency, markedness, and morphological change: on predicting the spread of noun-plural *-s* in Modern High German and West Germanic. In Yongkyoon No and Mark Libucha (eds), *Proceedings of the 7th Eastern States Conference on Linguistics* (pp. 136–53). Columbus: Ohio State University, Department of Linguistics.
- (1994a). Language change always occurs in the present: or, on taking the uniformitarian hypothesis seriously. Presidential Address to the 23rd Meeting of the Linguistic Association of the Southwest; Houston, Texas; October 21–3, 1994.
- (1994b). Checking theory, syntactic feature geometry, and the structure of IP. In Erin Duncan, Donka Farkas, and Philip Spaelti (eds), *Proceedings of the Twelfth West Coast Conference on Formal Linguistics (1993)* (pp. 319–38). Stanford: CSLI (for the Stanford Linguistics Association).
- (1995). From agreement affix to subject “clitic” – and bound root: *mos* > *-nos* versus *(-nos(-))* and *nos-otros* in New Mexican and other regional Spanish dialects. *CLS* 31, no. 1, 118–39.
- (1996). Form and content in a functionalist semiotic model of morphonology: comments on Dressler. In Singh 1996 (pp. 84–96).
- (1998a). German umlaut: morpholexical all the way down from OHG (two *Stützpunkte* for Romance metaphony). *Rivista di Linguistica* 10, 165–234.
- (1998b). Comments on the paper by Perlmutter. In Steven G. Lapointe, Diane K. Brentari, and Patrick M. Farrell (eds), *Morphology and its Relation to Phonology and Syntax* (pp. 339–59). Stanford: CSLI Publications.
- (1999a). “Elsewhere” cases and their sources: origins of morphological default rules and the case of German plural *-s*. Manuscript, Ohio State University.

- (1999b). Accounts of phonemic split have been greatly exaggerated – but not enough. In John J. Ohala, Yoko Hasegawa, Manjari Ohala, Daniel Granville, and Ashlee C. Bailey (eds), *Proceedings of the 14th International Congress of Phonetic Sciences; San Francisco, 1–7 August 1999; Volume 1* (pp. 329–32). Department of Linguistics, University of California, Berkeley.
- (2001). Beyond “pathways” and “unidirectionality”: on the discontinuity of language transmission and the counterability of grammaticalization. In Campbell 2001b (pp. 265–340).
- Janda, Richard D. and Auger, Julie (1992). Quantitative evidence, qualitative hypercorrection, sociolinguistic variables, and French speakers’ ‘eadhaches with English h/0. *Language and Communication* 12, 195–236.
- Janda, Richard D. and Joseph, Brian D. (1992). Meta-templates and the underlying (dis-)unity of Sanskrit reduplication. In Germán Westphal, Benjamin Ao, and Hee-Rahk Chae (eds), *Proceedings of the Eighth Eastern States Conference on Linguistics (1991)* (pp. 160–73). Columbus: Ohio State University, Department of Linguistics.
- (1999). The Modern Greek negator *mi(n)(-)* as a morphological constellation. In Giórgios Babiniótiš and Amalía Mózer (eds), *Greek Linguistics ‘97: Proceedings of the 3rd International Conference on the Greek Language (University of Athens; September 25–27, 1997)* (pp. 341–51). Athens: Eliniká Grámata.
- (2001). Reconsidering the canons of sound change: towards a Big Bang theory. Paper presented at 15th International Conference on Historical Linguistics, Melbourne. [To appear in *Selected Papers from the ICHL 15*, eds. Barry Blake and Kate Burridge. Amsterdam: John Benjamins, 2003.]
- Janda, Richard D. and Kathman, David (1992). Shielding morphology from exploded INFL. *CLS* 28(2), 141–57.
- Janda, Richard D. and Varela-García, Fabiola (1991). On lateral hermaphroditism and other variation in Spanish “feminine” *el*. In Lise Dobrin, Lynn Nichols, and Rosa M. Rodríguez (eds), *CLS* 27, no. 1 (pp. 276–90). Chicago: Chicago Linguistic Society.
- Janda, Richard D., Joseph, Brian D., and Jacobs, Neil (1994). Systematic hyperforeignisms as maximally external evidence for linguistic rules. In S. Lima, R. Corrigan, and G. Iverson (eds), *The Reality of Linguistic Rules* (pp. 67–92). Amsterdam: John Benjamins.
- Janson, Tore (1983). Sound change in perception and production. *Language* 59(1), 18–34.
- Jasanoff, Jay (1988). Review of Renfrew 1987. *Language* 64(4), 800–2.
- Jeffers, Robert J. and Lehiste, Ilse (1979). *Principles and Methods for Historical Linguistics*. Cambridge, MA: MIT Press.
- Jeffers, Robert J. and Zwicky, Arnold M. (1980). The evolution of clitics. In Elizabeth C. Traugott, Rebecca Labrum, and Susan C. Shepherd (eds), *ICHL* 4 (pp. 221–31). Amsterdam: John Benjamins. (CILT 14.)
- Jespersen, Otto (1894). *Progress in Language with Special Reference to English*. London: Swan Sonnenschein.
- (1909). *A Modern English Grammar on Historical Principles. Part I: Sounds and Spellings*. Copenhagen: Munksgaard.
- (1921). *Language: Its Nature, Development and Origin*. New York: Macmillan.
- (1941). Efficiency in linguistic change. [Repr. in his *Selected Writings* (pp. 381–466). London: Allen and Unwin, 1962.]
- Job, Michael (1995). Did Proto-Indo-European have glottalized stops? *Diachronica: International Journal for Historical Linguistics* 12(2), 237–50.
- Johanson, Lars (1992). *Strukturelle Faktoren in Türkischen Sprachkontakten*. Stuttgart: Franz Steiner Verlag.

- (1993). Code copying in immigrant Turkish. In Guus Extra and Ludo Verhoeven (eds), *Immigrant Languages in Europe* (pp. 197–221). Clevedon and Philadelphia: Multilingual Matters.
- (1999). Frame-changing code copying in immigrant varieties. In Guus Extra and Ludo Verhoeven (eds), *Bilingualism and Migration* (pp. 247–60). Berlin and New York: Mouton de Gruyter.
- (2001). On Bulgarian copies of Turkish suffixes. In Birgit Iгла and Thomas Stolz (eds), *“Was ich noch sagen wollte . . .”: A Multilingual Festschrift for Norbert Boretzky on the Occasion of his 65th Birthday* (pp. 177–80). Berlin: Akademie-Verlag. (*Studia typologica 2. Sprachtypologie und Universalienforschung, Beihefte/Language Typology and Universals, Supplements.*)
- Johnson, Theodore C. (1983). Phonological free variation, word frequency, and lexical diffusion. Ph.D. dissertation, University of Washington, Seattle.
- Jonas, D. (1996). Clause structure and verb syntax in Scandinavian and English. Ph.D. dissertation, Harvard University.
- Jonasson, J. (1971). Perceptual similarity and articulatory reinterpretation as a source of phonological innovation. *Speech Transmission Laboratory (Stockholm), Quarterly Progress and Status Report 1*, 30–41.
- Jones, Charles (1988). *Grammatical Gender in English: 950 to 1250*. London: Croom Helm.
- (1989). *A History of English Phonology*. Harlow: Longman.
- (ed.) (1993). *Historical Linguistics: Problems and Perspectives*. London and New York: Longman.
- Jones, Steve (1999). *Almost Like a Whale*. London: Doubleday. [Pub. as *Darwin's Ghost: The Origin of Species Updated*, New York: Random House, 2000.]
- Jongen, René (1986). Sandhi im Südniederfränkischen. In Henning Andersen (ed.), *Sandhi Phenomena in the Languages of Europe* (pp. 329–83). Berlin: Mouton.
- Joos, Martin (1952). The medieval sibilants. *Language* 28(2), 222–31.
- (1957). [Editorial comment]. In Martin Joos (ed.), *Readings in Linguistics (I)*. New York: ACLS, 83. [Repr. Chicago: University of Chicago Press, 4th edn, 1966.]
- (1986). *Notes on the Development of the Linguistic Society of America, 1924 to 1950*. Ithaca, NY: Linguistica.
- Joseph, Brian D. (1980a). Watkins' law and the modern Greek preterite. *Die Sprache* 26, 179–85.
- (1980b). Linguistic universals and syntactic change. *Language* 56(2), 345–70.
- (1981). Hittite *ivar*, *wa(r)* and Sanskrit *iva*. *Zeitschrift für vergleichende Sprachforschung* 94, 93–7.
- (1983a). *The Synchrony and Diachrony of the Balkan Infinitive: A Study in Areal, General, and Historical Linguistics*. Cambridge: Cambridge University Press.
- (1983b). Modern Greek linguistics from the Balkan perspective: a survey. *Mandatoros* 22, 13–26.
- (1990). *Morphology and Universals in Syntactic Change: Evidence from Medieval and Modern Greek*. New York: Garland. (Outstanding Dissertations in Linguistics Series.) [Expanded and updated version of Harvard University Ph.D. Dissertation, 1978.]
- (1992). Diachronic explanation: putting speakers back into the picture. In Garry W. Davis and Gregory K. Iverson (eds), *Explanation in Historical Linguistics* (pp. 123–44). Amsterdam and Philadelphia: John Benjamins. (CILT 84.)
- (1997). How general are our generalizations?: What speakers actually know and what they actually do. In Anthony D. Green and Virginia Motopanyane (eds), *ESCOL*,

- 96: *Proceedings of the 13th Eastern States Conference on Linguistics* (pp. 148–60). Ithaca, NY: Cascadilla Press.
- (1998). Historical morphology. In Spencer and Zwicky 1998 (pp. 351–73).
- (2001a). Is there such a thing as “grammaticalization”? In Campbell 2001b (pp. 163–86).
- (2001b). Historical linguistics. In Mark Aronoff and Janie Rees-Miller (eds), *Handbook of Linguistics* (pp. 105–29). Oxford: Blackwell.
- Joseph, Brian D. and Janda, Richard D. (1988). The how and why of diachronic morphologization and demorphologization. In Hammond and Noonan 1988 (pp. 193–213).
- Joseph, Brian D. and Pappas, Panayiotis A. (2002). On some recent views concerning the development of the Greek future system. *Byzantine and Modern Greek Studies* 28, 248–74.
- Joseph, Brian D. and Philippaki-Warbuton, Irene (1987). *Modern Greek*. London: Croom Helm.
- Joseph, Brian D. and Salmons, Joseph (eds) (1998). *Nostratic: Sifting the Evidence*. Amsterdam: John Benjamins. (CILT, 142.)
- Joseph, Brian D. and Schourup, Lawrence (1982–3). More on (i)-wa(r). *Zeitschrift für vergleichende Sprachforschung* 96, 56–9.
- Joseph, Brian Daniel and Wallace, Rex E. (1992). Socially determined variation in Ancient Rome. *Language Variation and Change* 4(1), 105–19.
- (1994). Proto-Indo-European voiced aspirates in Italic: a test for the glottalic theory. *Historische Sprachforschung* 107, 244–61.
- Jucker, Andreas H. (ed.) (1995). *Historical Pragmatics: Pragmatic Developments in the History of English*. Amsterdam: John Benjamins.
- Jucker, Andreas H., Fritz, Gerd, and Lebsanft, Franz (eds) (1999). *Historical Dialogue Analysis*. Amsterdam and Philadelphia: John Benjamins.
- Jud, Jakob (ed.) (1936ff). *Vox romanica* 1ff. Bern: Francke.
- (1973). *Romanische Sprachgeschichte und Sprachgeographie: Ausgewählte Aufsätze*, eds Konrad Huber and Gustav Ineichen. Zurich: Atlantis.
- Jurafsky, Daniel (1996). Universal tendencies in the semantics of the diminutive. *Language* 72, 533–78.
- Kahn, Daniel (1976). Syllable-based generalizations in English phonology. Ph.D. dissertation, MIT. [Pub. New York: Garland, 1980. (Outstanding Dissertations in Linguistics series.)]
- Kaila, Eino (1945). Hahmoproleemasta ynnä muutamista muista teoreettisen psykologian ongelmista. *Ajatus* 13, 5–89.
- Kaiser, Mark and Shevoroshkin, Vitaly (1988). Nostratic. *Annual Review of Anthropology* 17, 309–30.
- Kaisse, Ellen M. (1982). Sentential clitics and Wackernagel’s Law. In Daniel P. Flickinger, Marlys Macken, and Nancy Wiegand (eds), *Proceedings of the First West Coast Conference on Formal Linguistics* (pp. 1–14). Stanford, CA: Department of Linguistics.
- Kaku, Michio (1994). *Hyperspace: A Scientific Odyssey through Parallel Universes, Time Warps, and the Tenth Dimension*. New York: Oxford University Press.
- (1997). *Visions: How Science will Revolutionize the 21st Century*. New York: Anchor Books.
- Kant, Immanuel (1781). *Kritik der reinen Vernunft*. Riga. [2nd edn, “B,” 1787. Trans. Norman Kemp Smith as *Critique of Pure Reason*, London: Macmillan, 1933. German edn by Raymund Schmidt and Heiner Klemme, Hamburg: F. Meiner, 1990.]

- Karlsson, Keith (1981). *Syntax and Affixation: The Evolution of MENTE in Latin and Romance*. Tübingen: Niemeyer. (Beihefte zur Zeitschrift für romanische Philologie, 182.)
- Kaufman, Terence (1990). Language history in South America: what we know and how to know more. In Doris Payne (ed.), *Amazonian Linguistics* (pp. 13–31). Austin: University of Texas Press.
- Kay, D. and Anglin, J. M. (1982). Overextension and underextension in the child's expressive and receptive speech. *Journal of Child Language* 9, 83–98.
- Kay, Paul (1975). Synchronic variability and diachronic change in basic color terms. *Language in Society* 4, 257–70.
- (1976). Discussion of the two preceding papers. In Harnad et al. 1976 (pp. 117–19).
- Keel, William (1977a). On the predictability of lexical diffusion. In CILS 13, no. 1 (pp. 186–97).
- (1977b). Atomic phonology and phonological variation. Ph.D. dissertation, Indiana University, 1977. [Pub. Tübingen: Narr, 1982.]
- Keenan, Edward L. and Comrie, Bernard (1977). Noun phrase accessibility and universal grammar. *Linguistic Inquiry* 8(1), 63–99.
- Keiler, Allan R. (ed.) (1972). *A Reader in Historical and Comparative Linguistics*. New York: Holt, Rinehart, and Winston.
- Keller, Evelyn Fox and Lloyd, Elisabeth Anne (eds) (1992). *Keywords in Evolutionary Biology*. Cambridge, MA: Harvard University Press.
- Keller, Rudi (1990). *Sprachwandel: von der unsichtbaren Hand in der Sprache*. Tübingen: Francke.
- (1994). *On Language Change: The Invisible Change in Language*. London and New York: Routledge. [Transl. of German version, *Sprachwandel*, 1990.]
- (1995). *Zeichentheorie: zu einer Theorie semiotischen Wissens*. Tübingen and Basel: Francke. [Trans. Kimberley Duenwald as *Theory of Linguistic Signs*. New York: Oxford University Press, 1998.]
- Kellermann, Günter and Morrissey, Michael D. (eds) (1992). *Diachrony within Synchrony: Language History and Cognition*. Frankfurt: Peter Lang.
- Kellogg, D. E. (1988). "And then a miracle occurs" – weak links in the chain of argument from punctuation to hierarchy. *Biology and Philosophy* 3, 3–28.
- Kemmer, Suzanne E. (1993). *The Middle Voice*. Amsterdam and Philadelphia: John Benjamins. (TSL 23.)
- (1995). An analogical model of syntactic change. Paper presented at the Conference on Functional Approaches to Grammar, University of New Mexico, July 1995.
- Kennedy, John F. (1962). Address at the University of California, Berkeley. March 23, 1962. In *Public Papers of the Presidents of the United States: John F. Kennedy 1962* (p. 266). Washington, DC: Federal Register Division, National Archives and Records Service, General Services Administration. (Distributed by the Superintendent of Documents, US Government Printing Office.)
- Kenstowicz, Michael and Kisseberth, Charles (1979). *Generative Phonology: Description and Theory*. New York: Academic Press.
- Kerswill, Paul (1996). Children, adolescents and language change. *Language Variation and Change* 8(2), 177–202.
- Key, T. H. (1855). On vowel-assimilation, especially in relation to Professor Willis's experiment on vowel-sounds. *Transactions of the Philological Society* [London] 5, 191–204.
- Keyser, Samuel J. and O'Neil, Wayne A. (1985). *Rule Generalization and Optionality in Language Change*. Dordrecht: Foris. (Studies in Generative Grammar, 23.)

- Kibrik, A. E. (1979–81). *Materialy k tipologii ergationosti: 1. Arčinski jazyk; 4. Tabasarskij jazyk; 5. Agul'skij jazyk; 6. Caxurskij jazyk; 7. Rutul'skij jazyk; 8. Lezginiskij jazyk; 17. Xinalugskij jazyk; 18. Buduxskij jazyk; 19. Kryzskij jazyk*. Moscow: Institut russkogo jazyka, AN SSR. (Predvaritel'nye publikacii, vypusk 126, 128, 129, 141.)
- (1994). Archi. In Smeets 1994 (pp. 297–366).
- Kibrik, A. E. and Kodzasov, S. V. (1990). *Sopostavitel'noe izučenie dagestanskix jazykov: Imja. Fonetika*. Moscow: Moscow University Press.
- Kilani-Schoch, Marianne (1988). *Introduction à la morphologie naturelle*. Bern: Lang.
- Kilian-Hatz, Christa (1995). *Das Baka: Grundzüge einer Grammatik aus der Grammatikalisierungsperspektive*. Cologne: Institut für Afrikanistik, Universität zu Köln. (AMO, Afrikanistische Monographien, 6.)
- Kim, Hyeree (1995). On the genitive of the Anglo-Saxon *Deor*. *Neuphilologische Mitteilungen* 96, 351–9.
- Kim, J. J., Marcus, G. F., Pinker, S., Hollander, M., and Coppola, M. (1994). Sensitivity of children's inflection to grammatical structure. In Katharine Perera, Glyn Collis, and Brian Richards (eds), *Growing Points in Child Language* (pp. 173–209). Cambridge: Cambridge University Press. (Special issue of *Journal of Child Language* 2(1).)
- Kim, Sung-Won and Thorne, Kip S. (1991). Do vacuum fluctuations prevent the creation of closed timelike curves? *Physical Review D* 43, 3939–47.
- Kimball, Geoffrey (1992). A critique of Muskogean, "Gulf," and Yukian material in Greenberg 1987. *International Journal of American Linguistics* 58, 447–501.
- Kimbel, William H. and Martin, Lawrence B. (eds) (1993). *Species, Species Concepts, and Primate Evolution*. New York: Plenum Press. (Advances in Primatology.)
- King, M. C. and Wilson, Alan C. (1975). Evolution at two levels: molecular similarities and biological differences between humans and chimpanzees. *Science* 188, 107–16.
- King, Robert D. (1969). *Historical Linguistics and Generative Grammar*. Englewood Cliffs, NJ: Prentice Hall.
- King, Tracy Holloway (1995). *Configuring topic and focus in Russian*. Stanford, CA: CSLI, Stanford University. (Dissertations in Linguistics.) [Distributed by Cambridge University Press.]
- Kiparsky, Paul (1965). Phonological change. Ph.D. dissertation, MIT.
- (1966). Über den deutschen Akzent. In *Studia Grammatica VII. Untersuchungen über Akzent und Intonation im Deutschen* (pp. 69–98). Berlin: Akademie-Verlag. (Deutsche Akademie der Wissenschaften zu Berlin, Arbeitsstelle Strukturelle Grammatik.)
- (1968). Linguistic universals and linguistic change. In Emmon Bach and Robert T. Harms (eds), *Universals in Linguistic Theory* (pp. 171–202). New York: Holt, Rinehart and Winston. [Repr. in Keiler 1972 (pp. 338–67). Also in Baldi and Werth 1978 (pp. 218–35, as part of ch. 11, "Rule reordering").]
- (1971). Historical linguistics. In Dingwall 1971 (pp. 576–642). [Repr. in Baldi and Werth 1978 (pp. 218–35, as part of ch. 11, "Rule reordering.")]
- (1973a). *Three Dimensions of Linguistic Theory*, ed. Osamu Fujimura. Tokyo: TEC.
- (1973b). Abstractness, opacity, and global rules. In Kiparsky 1973a (pp. 57–86).
- (1973c). Case studies. In Kiparsky 1973a (pp. 57–86).
- (1974a). Remarks on analogical change. In Anderson and Jones 1974b (pp. 257–75).
- (1974b). From paleogrammarians to neogrammarians. In Hymes 1974 (pp. 331–45).
- (1974c). A note on vowel features. In E. Kaisse and J. Hankamer (eds), *NELS* 5, 162–71.
- (1976). Historical linguistics and the origin of language. In Harnad et al. 1976 (pp. 97–103).

- (1978). Analogical change as a problem for linguistic theory. *Studies in the Linguistic Sciences* 8(2), 77–96.
- (1980). Concluding statement. In Elizabeth C. Traugott, Rebecca Labrum, and Susan C. Shepherd (eds), *ICHL 4* (pp. 409–17). Amsterdam: John Benjamins. (CILT 14.)
- (1982). Lexical phonology and morphology. In Linguistic Society of Korea (ed.), *Linguistics in the Morning Calm* (pp. 3–91). Seoul: Hanshin.
- (1985). Some consequences of lexical phonology. *Phonology* 2, 85–138.
- (1988). Phonological change. In Newmeyer 1988 (pp. 363–415).
- (1993). Blocking in non-derived environments. In Sharon Hargus and Ellen M. Kaisse (eds), *Studies in Lexical Phonology* (pp. 277–313). San Diego: Academic Press.
- (1995a). Indo-European origins of Germanic syntax. In Battye and Roberts 1995 (pp. 140–69).
- (1995b). The phonological basis of sound change. In John A. Goldsmith (ed.), *The Handbook of Phonological Theory* (pp. 640–70). Oxford: Blackwell. [Repr. in this volume.]
- (1996a). The shift to head-initial VP in Germanic. In H. Thráinsson, S.D. Epstein, and S. Peter (eds), *Studies in Comparative Germanic Syntax II*. Dordrecht: Kluwer.
- (1996b). Allomorphy or morphophonology? In Singh 1996 (pp. 13–31).
- (1997). The rise of positional licensing. In van Kemenade and Vincent 1997 (pp. 460–94).
- Kiparsky, Valentin (1932). Johdatusta fonologiaan. *Virittäjä* 36, 230–50. [Partial German transl. in Korhonen 1971.]
- Kirchner, Robert M. (1997). Contrastiveness and faithfulness. *Phonology* 14(1), 83–111.
- (1998). An effort-based approach to consonant lenition. Ph.D. dissertation, UCLA.
- Kirkman, Marshall Monroe (1900). *The Science of Railways, Volume 1: Railway Equipment*. Rev. and enlarged edn. New York: World Railway. [1st edition 1898.]
- Kitts, D. B. (1963). The theory of geology. In Claude C. Albritton, Jr. (ed.), *The Fabric of Geology* (co-directed by the Geological Society of America) (pp. 49–68). San Francisco, then Stanford: Freeman, Cooper. [2nd, corrected, pr. 1964.]
- Klatt, D. H. (1975). Voice onset time, frication, and aspiration in word-initial consonant clusters. *Journal of Speech and Hearing Research* 18, 686–706.
- Klausenburger, Jürgen (1976). (De)morphologization in Latin. *Lingua* 40, 305–20.
- (1979). *Morphologization: Studies in Latin and Romance morphophonology*. Tübingen: Niemeyer.
- (1984). *French Liaison and Linguistic Theory*. Stuttgart: Steiner.
- (2000). *Grammaticalization: Studies in Latin and Romance Morphosyntax*. Amsterdam: John Benjamins. (Current Issues in Linguistic Theory, 193.)
- Klein, Jared S. (1999). Theory versus practice in diachronic linguistics: review article . . . [on] Lass 1997. *Language Sciences* 21(1), 87–104.
- Klejn, Leo S. (1996). European archaeology. In Fagan 1996 (pp. 286–7).
- Klima, Edward (1964). Relatedness between grammatical systems. *Language* 40(1), 1–20. [Repr. in David Reibel and Sanford Schane (eds), *Modern Studies in English* (pp. 227–46). Englewood Cliffs, NJ: Prentice Hall, 1969.]
- (1965). Studies in diachronic transformational syntax. Ph.D. dissertation, Harvard University.
- Klindt-Jensen, Ole (1975). *A History of Scandinavian Archaeology*, transl. G. Russell Poole. London: Thames and Hudson.
- Kloeke, Gesinus Ger(h)ardus (1927). *De hollandsche expansie in de zestiende en zeventiende eeuw*. The Hague: Nijhoff.
- Kluge, Friedrich (1957). *Etymologisches Wörterbuch der deutschen Sprache*. 17th edn. Berlin: de Gruyter.

- Koch, Harold (1996). Reconstruction in morphology. In Durie and Ross 1996 (pp. 218–63).
- Koerner, E. F. Konrad (1972). Hermann Paul and synchronic linguistics. *Lingua* 29, 274–307.
- (1974). Foreword to the new edition. In Delbrück 1880 (pp. vii–xix).
- (1975). Ursprung und Geschichte der Besternung in der historischen Sprachwissenschaft: Eine historiographische Notiz. *Zeitschrift für vergleichende Sprachforschung* 89(2), 185–90.
- (1978a). *Toward a Historiography of Linguistics: Selected Essays*. Amsterdam: John Benjamins. (Studies in the History of the Language Sciences, 19.)
- (ed.) (1978b). *Western Histories of Linguistics: An Annotated, Chronological Bibliography, 1822–1976*. Amsterdam: John Benjamins. (Studies in the History of the Language Sciences, 11.)
- (1983a). Foreword. In Bloomfield 1914, repr. 1983.
- (ed.) (1983b). *August Schleicher, Die Sprachen Europas in systematischer Übersicht: Linguistische Untersuchungen*. Amsterdam and Philadelphia: John Benjamins. (Amsterdam Studies in the Theory and History of Linguistic Science: Amsterdam Classics in Linguistics, 4.)
- (1983c). The Schleicherian paradigm in linguistics. In Koerner 1983b (xxiii–lxxi). [Repr. from *General Linguistics* 23 (1982), 1–39.]
- (ed.) (1983d). *Linguistics and Evolutionary Theory: Three Essays by August Schleicher, Ernst Haeckel, and Wilhelm Bleek*. Amsterdam: John Benjamins. (Amsterdam Classics in Linguistics, 6.)
- (1989). *Practicing Linguistic Historiography: Selected Essays*. Amsterdam: John Benjamins. (Studies in the History of the Language Sciences, 50.)
- (ed.) (1991). *1st-Person Singular 2: Autobiographies by North American Scholars in the Language Sciences*. Amsterdam: John Benjamins. (Studies in the History of the Language Sciences, 61.)
- (1994a). Historiography of linguistics. In Asher and Simpson 1994 (vol. 3, pp. 1570–8).
- (1994b). History of linguistics: overview. In Asher and Simpson 1994 (vol. 3, pp. 1581–4).
- (ed.) (1998). *1st-Person Singular 3: Autobiographies by North American Scholars in the Language Sciences*. Amsterdam: John Benjamins. (Studies in the History of the Language Sciences, 88.)
- Koerner, E(rnst) F(rideryk) K(onrad) and R(onald) E. Asher (eds) (1995). *Concise History of the Language Sciences: From the Sumerians to the Cognitivists*. New York: Pergamon.
- Kolb, Eduard (1966). *Linguistic Atlas of England, Phonological Atlas of the Northern Region: The Six Northern Counties, North Lincolnshire and the Isle of Man*. Bern: Francke.
- König, Ekkehard (1985). Where do concessives come from? On the development of concessive connectives. In Fisiak 1985 (pp. 263–82).
- (1988). Concessive connectives and concessive sentences: cross-linguistic regularities and pragmatic principles. In Hawkins 1988b (pp. 145–66).
- (1991). *The Meaning of Focus Particles: A Comparative Perspective*. London: Routledge.
- König, Ekkehard and Siemund, Peter (2000). Intensifiers and reflexives: a typological perspective. In Frajzyngier and Curl 2000a (pp. 41–74).
- Koopman, W. F. (1990). *Word Order in Old English, with Special Reference to the Verb Phrase*. Amsterdam: Faculty of Arts. (Amsterdam Studies in Generative Grammar 1.)

- Korhonen, Mikko (1969). Die Entwicklung der morphologischen Methode im Lappischen. *Finnisch-Ugrische Forschungen* 37, 203–62.
- (1971). Nachtrag. *Finnisch-Ugrische Forschungen* 39, 80.
- Koselleck, Reinhart (1979). *Vergangene zukunft: Zur Semantik geschichtlicher Zeiten*. Frankfurt: Suhrkamp Verlag, 1979. [Transl. Keith Tribe as *Futures Passed: On the Semantics of Historical Time*, Cambridge, MA: MIT Press, 1985. (Studies in Contemporary German Social Thought.)]
- Koster, J. (1975). Dutch as an SOV language. *Linguistic Analysis* 1, 111–36.
- Krauss, Michael E. (1969). On the classification in the Athapaskan, Eyak, and Tlingit verb. *Supplement to International Journal of American Linguistics* 35(4), part II. Bloomington: Indiana University Press. (Indiana University Publications in Anthropology and Linguistics, memoir 24.)
- Krishnamurti, Bhadriraju (1978). Areal and lexical diffusion of sound change. *Language* 54(1), 1–20.
- Kristjánsdóttir, B., Halldórsson, B., Torfason, J., and Thorsson, Ö. (eds) (1991). *Heimskringla*. Reykjavik: Mál og menning.
- Kristjánsdóttir, B., Halldórsson, B., Sigurðsson, G., Grómsdóttir, G. A., Ingólfssdóttir, G., Torfason, J., Tómasson, S., and Thorsson, Ö. (eds) (1988). *Sturlunga saga*. Reykjavik: Svart á hvítu.
- Kroch, Anthony S. (1978). Toward a theory of social dialect variation. *Language in Society* 7(1) (1976), 17–36. [Repr. in Harold B. Allen and Michael D. Linn (eds), *Dialects and Language Variation* (pp. 344–66). New York: Academic Press, 1986; and in Michael Linn (ed.), *Handbook of Dialects and Language Variation* (pp. 245–66). San Diego: Academic Press, 1998.]
- (1989a). Reflexes of grammar in patterns of language change. *Journal of Language Variation and Change* 1(3), 199–244.
- (1989b). The loss of the verb-second constraint in Middle English and Middle French. Paper presented at NWAVE 18, Université de Montréal.
- (1995). Morphosyntactic variation. In *CLS* 30(2), 180–201.
- Kroch, Anthony S. and Taylor, Ann (1997). Verb movement in Old and Middle English: dialect variation and language contact. In van Kemenade and Vincent 1997 (pp. 297–325).
- (2000). Statistics and grammar: a study of Middle English phrase structure. In S. Pintzuk, G. Tsoulas, and A. Warner (eds), *Diachronic Syntax: Models and Mechanisms* (pp. 132–63). Oxford: Oxford University Press.
- Kroch, Anthony S., Taylor, Ann, and Ringe, Donald (2000). The Middle English verb-second constraint: a case study in language contact and language change. In Susan Herring, Pieter van Reenen, and Lene Schøsler (eds), *Textual Parameters in Older Language* (pp. 353–92). Amsterdam: John Benjamins.
- Kroeber, Alfred Louis (1935). History and science in anthropology. *American Anthropologist* 37, 539–69.
- Kruszewski, Mikołaj (1887). Prinzipien der Sprachentwicklung. III. Geschichte der Laute und Lautkomplexe. *Internationale Zeitschrift für allgemeine Sprachwissenschaft* 3, 145–87. [Trans. Gregory M. Eramian in *Writings in General Linguistics*. Mikołaj Kruszewski, ed. E. F. Konrad Koerner (pp. 65–86). Amsterdam: John Benjamins. (Amsterdam Classics in Linguistics 11.)]
- Krynine, Paul (1956). Uniformitarianism is a dangerous doctrine. *Journal of Paleontology* 30, 1003–4.
- Kučera, Henry and Francis, W. Nelson (1967). *Computational Analysis of Present-Day American English*. Providence: Brown University Press.

- Kulick, Don (1990). *Having Head and Showing Knowledge: Language Shift, Christianity, and Notions of Self in a Papua New Guinean Village*. Stockholm: Department of Social Anthropology, Stockholm University.
- Kuno, Susumu (1974). The position of relative clauses and conjunctions. *Linguistic Inquiry* 5(1), 117–36.
- Kurath, Hans, with Hanley, Miles L., Bloch, Bernard, Lowman, Guy S., Jr., and Hansen, Marcus L. (eds) (1939–43). *Linguistic Atlas of New England*. Providence: Brown University (sponsored by the American Council of Learned Societies [ACLS], and assisted by universities and colleges in New England).
- (1949). *A Word Geography of the Eastern United States*. Ann Arbor: University of Michigan Press.
- Kuryłowicz, Jerzy (1927). ə indo-européen et ħ hittite. *Symbolae grammaticae in honorem Ioannis Rozwadowski* 1, 95–104.
- (1945–9). La nature des procès dits “analogiques.” *Acta Linguistica* 5, 15–37. [Repr. in Hamp et al. 1966 (pp. 168–74). Trans. in Winters 1995 (pp. 113–45).]
- (1964). *The Inflectional Categories of Indo-European*. Heidelberg: Winter.
- (1965). The evolution of grammatical categories. *Diogenes* 51, 55–71. [Repr. in Kuryłowicz (1976), *Esquisses linguistiques* (vol. 2, pp. 38–54). Munich: Fink.]
- (1968). *Indogermanische Grammatik, 2: Akzent, Ablaut*. Heidelberg: Winter.
- Kuteva, Tania (1998). On identifying an evasive gram: action narrowly averted. *Studies in Language* 22(1), 113–60.
- (1999). On “sit”/“stand”/“lie” auxiliation. *Linguistics* 37(2), 191–213.
- (2001). *Auxiliation: An Enquiry into the Nature of Grammaticalization*. Oxford and New York: Oxford University Press.
- Kyes, Robert (1990). Evidence. In Polomé 1990 (pp. 303–6).
- Labov, William (1963). The social motivation of a sound change. *Word* 19(3), 273–309. [Repr. in Labov 1972a (pp. 1–42, 327–36).]
- (1965). On the mechanism of linguistic change. *Georgetown University Monographs on Languages and Linguistics* 18, 91–114. [Repr. in Keiler 1972 (pp. 267–88). Also in Labov 1972a (pp. 160–82, 327–36).]
- (1966). *The Social Stratification of English in New York City*. Washington, DC: Center for Applied Linguistics. [Repr. 1982.]
- (1969). Contraction, deletion, and inherent variability of the English copula. *Language* 45(4), 715–62.
- (1972a). *Sociolinguistic Patterns*. Philadelphia: University of Pennsylvania Press.
- (1972b). The internal evolution of linguistic rules. In Robert P. Stockwell and Ronald K. S. Macaulay (eds), *Linguistic Change and Generative Theory: Essays* (pp. 101–71). Bloomington: Indiana University Press. (Indiana University Studies in the History and Theory of Linguistics.)
- (1978). On the use of the present to explain the past. In Baldi and Werth 1978 (pp. 275–312). [Expanded from Luigi Heilmann (ed.), *Proceedings of the 11th International Congress of Linguists, Bologna – Florence, Aug. 28–Sept. 2, 1972. Vol. 2* (pp. 1110–35). Bologna: Il mulino.]
- (ed.) (1980a). *Locating Language in Time and Space*. New York: Academic Press.
- (1980b). The social origins of sound change. In Labov 1980a (pp. 251–66).
- (1981). Resolving the Neogrammarian controversy. *Language* 57(2), 267–309.
- (1989a). The child as linguistic historian. *Language Variation and Change* 1, 85–97.
- (1989b). Exact description of the speech community: short *a* in Philadelphia. In Ralph W. Fasold and Deborah Schiffrin (eds), *Language Change and Variation* (pp. 1–57). Amsterdam: John Benjamins. (CILT 22.)

- (1990). The interaction of sex and social class in the course of linguistic change. *Language Variation and Change* 2, 205–54.
- (1991). The three dialects of English. In Penelope Eckert (ed.), *New Ways of Analyzing Sound Change* (pp. 1–44). New York: Academic Press.
- (1994). *Principles of Linguistic Change: Internal Factors*. Oxford: Blackwell.
- (1997). Locating the leaders of linguistic change. Paper given at the 71st Annual Meeting of the Linguistic Society of America; Chicago, IL; January 2–5, 1997. [Abstract in *Meeting Handbook* (pp. 58–9).]
- (1999). The role of outliers in the incrementation of linguistic change. Paper given at the 73rd Annual Meeting of the Linguistic Society of America; Los Angeles, CA; January 7–10, 1999. [Abstract in *Meeting Handbook* (p. 71).]
- (2001). *Principles of Linguistic Change: Social Factors*. Oxford: Blackwell.
- Labov, William, Yaeger, Malcah, and Steiner, Richard (1972). *A Quantitative Study of Sound Change in Progress*. Philadelphia: U.S. Regional Survey.
- Ladefoged, P. (1984). “Out of chaos comes order”: physical, biological, and structural patterns in phonetics. In M. P. R. van den Broecke and A. Cohen (eds), *Proceedings of the 10th International Congress of Phonetic Sciences* (pp. 83–95). Dordrecht: Foris.
- Ladefoged, Peter and Broadbent, D. E. (1957). Information conveyed by vowels. *Journal of the Acoustical Society of America* 29(1), 98–104.
- Ladefoged, Peter and Maddieson, Ian (1996). *The Sounds of the World’s Languages*. Oxford: Blackwell.
- Lakoff, George (1987). *Women, Fire, and Dangerous Things: What Categories Reveal About the Mind*. Chicago: University of Chicago Press.
- Lamarche, Jacques (1996). Gender agreement and suppletion in French. In Karen Zagona (ed.), *Grammatical Theory and Romance Languages* (pp. 145–57). Amsterdam: Benjamins.
- Lambert, David M. and Hamish, G. Spencer (eds) (1995). *Speciation and the Recognition Concept: Theory and Application*. Baltimore, MD: Johns Hopkins University Press.
- Lambrecht, Knud (1981). *Topic, Antitopic and Verb Agreement in Non-Standard French*. Amsterdam: John Benjamins.
- Landau, Barbara and Gleitman, Lila R. (1985). *Language and Experience: Evidence from the Blind Child*. Cambridge, MA: Harvard University Press.
- Lande, Russell (1980). Genotypic variation and phenotypic evolution during allopatric speciation. *American Naturalist* 116, 463–79.
- (1986). The dynamics of peak shifts and the pattern of morphological evolution. *Paleobiology* 12, 343–54.
- Langacker, Ronald W. (1977). Syntactic reanalysis. In Li 1977 (pp. 59–139).
- (1987). *Foundations of Cognitive Grammar, Volume 1*. Stanford: Stanford University Press.
- (1990). Subjectification. *Cognitive Linguistics* 1, 5–38.
- (1994). Conceptual grouping and constituency in cognitive grammar. *Linguistics in the Morning Calm* 3, 149–72.
- Langdon, Margaret (1975). Boundaries and lenition in Yuman languages. *International Journal of American Linguistics* 41, 218–33.
- Lasnik, Howard (1999). *Minimalist Analysis*. Oxford: Blackwell.
- Lass, Roger (1975). How intrinsic is content? Markedness, sound change, and family universals. In Didier Goyvaerts and Geoffrey K. Pullum (eds), *Essays on the Sound Pattern of English* (pp. 475–504). Ghent: Story-Scientia.

- (1978). Mapping constraints in phonological reconstruction: on climbing down trees without falling out of them. In Jacek Fisiak (ed.), *Recent Developments in Historical Phonology* (pp. 245–86). The Hague: Mouton. (TIL 4.)
- (1980). *On Explaining Language Change*. Cambridge: Cambridge University Press.
- (1981). Explaining sound change: the future of an illusion. In Wolfgang U. Dressler, Oskar E. Pfeiffer, John R. Rennison et al. (eds), *Phonologica 1980: Akten der 4. Internationalen Phonologie-Tagung; Wien, 29 Juni – 2 Juli 1980* (pp. 257–73). Innsbruck: Institut für Sprachwissenschaft, Universität Innsbruck. (Innsbrucker Beiträge zur Sprachwissenschaft, 36.)
- (1986). Conventionalism, invention, and “historical reality”: some reflections on method. *Diachronica* 3(1), 15–41.
- (1987). Language, speakers, history, and drift. In W. Koopman, F. van der Leek, O. Fischer, and R. Eaton (eds), *Explanation and Linguistic Change* (pp. 151–76). Amsterdam: John Benjamins.
- (1990). How to do things with junk: exaptation in language evolution. *Journal of Linguistics* 26, 79–102.
- (1994). *Old English: A Historical Linguistic Companion*. Cambridge: Cambridge University Press.
- (1997). *Historical Linguistics and Language Change*. Cambridge: Cambridge University Press. (CSL 81.)
- Laudan, Rachel (1982). The role of methodology in Lyell’s science. *Studies in the History and Philosophy of Science* 13, 215–49.
- (1987). *From Mineralogy to Geology: The Foundations of a Science, 1650–1830*. Chicago: University of Chicago Press. (Science and its Conceptual Foundations.)
- Lausberg, Heinrich (1962). *Romanische Sprachwissenschaft*. Vol. 3. Berlin: de Gruyter.
- Lawton, John H. and May, Robert McCredie (eds) (1995). *Extinction Rates*. Oxford: Oxford University Press.
- Lee, Gregory (1975). Natural phonological descriptions, 1. *Working Papers in Linguistics* 7(5), 85–125. University of Hawaii.
- Leed, Richard L. (1970). Distinctive features and analogy. *Lingua* 26(1), 1–24.
- Le Grand, H. E. (1988). *Drifting Continents and Shifting Theories: The Modern Revolution in Geology and Scientific Change*. Cambridge: Cambridge University Press.
- Lehmann, Christian (1982). *Thoughts on Grammaticalization: A Programmatic Sketch*. Vol. 1. Cologne: Universität zu Köln, Institut für Sprachwissenschaft. (Arbeiten des Kölner Universalien-Projekts, 48.) [Pub. as *Thoughts on Grammaticalization*, Munich: LINCOM EUROPA, 1995.]
- (1984). *Der Relativsatz: Typologie seiner Strukturen, Theorie seiner Funktionen, Kompendium seiner Grammatik*. Tübingen: Gunter Narr.
- (1985). Grammaticalization: synchronic variation and diachronic change. *Lingua e Stile* 20(3), 303–18.
- (1992). Word order change by grammaticalization. In Marinel Gerritsen and Dieter Stein (eds), *Internal and External Factors in Syntactic Change* (pp. 395–416). Berlin: Mouton de Gruyter.
- (1993). Theoretical implications of grammaticalization phenomena. In William A. Foley (ed.), *The Role of Theory in Language Description* (pp. 315–40). Berlin: Mouton. (TIL 69.)
- Lehmann, Winfred P. (1962). *Historical Linguistics*. New York: Holt.
- (ed.) (1967). *A Reader in 19th Century Historical Indo-European Linguistics*. Bloomington: Indiana University Press.

- (1973). *Historical Linguistics*. 2nd edn. New York: Holt, Rinehart and Winston.
- (1974). *Proto-Indo-European Syntax*. Austin: University of Texas Press.
- (1976). A preface to diachronic syntactic investigation. In Sanford B. Steever, Carol A. Walker, and Salikoko S. Mufwene (eds), *Papers from the Parasession on Diachronic Syntax* [= CLS 12, no. 2] (pp. 169–78). Chicago: CLS.
- (1992). *Historical Linguistics*. 3rd edn. London and New York: Routledge.
- Lehmann, Winfred P. and Malkiel, Yakov (eds) (1968). *Directions for Historical Linguistics: A Symposium*. Austin: University of Texas Press.
- Lehmann, Winfred Philipp and Zgusta, Ladislav (1979). Schleicher's tale after a century. In Brogyanyi 1979 (vol. 1, pp. 455–66).
- Lehrer, Adrienne (1985). The influence of semantic fields on semantic change. In Fisiak 1985 (pp. 283–96).
- Lehti-Eklund, H. (1990). *Från adverb till markör i text: Studier i semantisk-syntaktisk utveckling i äldre svenska*. Helsinki: Humanistika avhandlingar.
- Lenneberg, E. H. (1967). *Biological Foundations of Language*. New York: Academic Press.
- Lenski, Richard and Travisano, Michael (1994). Dynamics of adaptation and diversification: a 10,000-generation experiment with bacterial populations. *Proceedings of the National Academy of Sciences of the United States of America* 91(15), 6808–14.
- Le Poidevin, Robin (1991). *Change, Cause, and Contradiction*. Basingstoke and London: Macmillan.
- (ed.) (1998). *Questions of Time and Tense*. Oxford: Clarendon Press.
- Le Poidevin, Robin and MacBeath, Murray (eds) (1993). *The Philosophy of Time*. Oxford: Oxford University Press. (Oxford Readings in Philosophy.)
- Leopold, Werner (1930). Polarity in language. In James Taft Hatfield, Werner Leopold, and Andreas Johannes Friedrich Zieglschmid (eds), *Curme Volume of Linguistic Studies, . . . on the Occasion of his Seventieth Birthday* (pp. 102–9). Baltimore: Waverly Press.
- Lepschy, Giulio C[esare] (ed.) (1994ff). *Storia della linguistica./History of Linguistics*. London: Longman.
- (1996). *La linguistica del Novecento*. Bologna: Il mulino. [2nd, updated edn; 1st edn, 1992.] (Vie della civiltà.)
- Leskien, August (1876). *Die Declination im Slavisch-Litauischen und Germanischen*. Leipzig: Hirzel.
- Leslau, W. (1969). Frequency as a determinant of linguistic change in the Ethiopian languages. *Word* 25, 180–9.
- Levine, Amy-Jill (1998). Visions of kingdoms: from Pompey to the first Jewish revolt. In Michael D. Coogan (ed.), *The Oxford History of the Biblical World* (pp. 466–514). New York: Oxford University Press.
- Levinson, Steven C. (1983). *Pragmatics*. Cambridge: Cambridge University Press. (Cambridge Textbooks in Linguistics.)
- (1995). Three levels of meaning. In F. R. Palmer (ed.), *Grammar and Meaning: Essays in Honor of Sir John Lyons* (pp. 90–115). Cambridge: Cambridge University Press.
- Levinton, Jeffrey S. (1988). *Genetics, Paleontology, and Macroevolution*. Cambridge: Cambridge University Press.
- Levinton, Jeffrey S. and Simon, C. M. (1980). Critique of the punctuated equilibria model and implications for the detection of speciation in the fossil record. *Systematic Zoology* 29, 130–42.
- Lewis, David K. (1976). The paradoxes of time travel. *American Philosophical Quarterly* 13, 142–52. [Repr. in Lewis 1986 (vol. 2, pp. 67–80).]
- (1986). *Philosophical Papers*. Vols 1–2. New York: Oxford University Press.

- Lewis, Henry and Pedersen, Holger (1937). *A Concise Comparative Celtic Grammar*. Göttingen: Vandenhoeck and Ruprecht. [2nd edn, 1961. 3rd edn, 1974.]
- Li, Charles N. (ed.) (1975). *Word Order and Word Order Change*. Austin: University of Texas Press.
- (ed.) (1976). *Subject and Topic*. New York: Academic Press.
- (ed.) (1977). *Mechanisms of Syntactic Change*. Austin: University of Texas Press.
- Li, Fang-kuei (1977). *A Handbook of Comparative Tai*. Honolulu: University of Hawaii.
- Li, Li.-Xin and Gott, J. Richard (1998). Self-consistent vacuum for Misner Space and the Chronology Protection Conjecture. *Physical Review Letters* 80, 2980–3.
- Liberman, Anatoly (1991). Phonologization in Germanic: umlauts and vowel shifts. In Elmer Antonsen and Hans Henrich Hock (eds), *Stæfcræft ...* (pp. 125–37). Amsterdam: John Benjamins.
- Liddell Hart, Basil Henry (1928). Ferdinand Foch: the symbol of the victorious will. In *Reputations Ten Years After* (pp. 149–78). Boston: Little, Brown. (Atlantic Monthly Press.)
- (1932). *Foch: The Man of Orleans*. Boston: Little, Brown. (Atlantic Monthly Press.)
- Lieber, Rochelle (1979). The English passive: an argument for historical rule stability. *Linguistic Inquiry* 10, 667–88.
- (1987). *An Integrated Theory of Autosegmental Processes*. Albany: SUNY Press.
- (1992). *Deconstructing Morphology*. Chicago: University of Chicago Press.
- Lieberman, B. S., Brett, C. E., and Eldredge, Niles (1995). A study of stasis and change in two species lineages from the Middle Devonian of New York State. *Paleobiology* 21, 15–27.
- Lieberman, Philip (1991). *Uniquely Human: The Evolution of Speech, Thought, and Selfless Behavior*. Cambridge, MA: Harvard University Press.
- Lighter, J. E., Ball, J., and O'Connor, J. (eds) (1994). *Random House Historical Dictionary of American Slang. Vol. 1*. New York: Random House.
- Lightfoot, David W. (1979). *Principles of Diachronic Syntax*. Cambridge: Cambridge University Press.
- (1980). The history of NP movement. In Teun Hoekstra, Harry van der Hulst, and Michael Moortgat (eds), *Lexical Grammar* (pp. 255–84). Foris: Dordrecht.
- (1981). A reply to some critics. *Lingua* 55, 351–68.
- (1982). *The Language Lottery: Toward a Biology of Grammars*. Cambridge, MA: MIT Press.
- (1983). On reconstructing a proto-syntax. In I. Rauch and G. Carr (eds), *Language Change* (pp. 128–42). Bloomington: Indiana University Press.
- (1991). *How to Set Parameters: Arguments from Language Change*. Cambridge, MA: MIT Press.
- (1993). Why UG needs a learning theory: triggering verb movement. In Jones 1993 (pp. 190–214). [Repr. in Battye and Roberts 1995 (pp. 31–52).]
- (1995). Grammars for people. *Journal of Linguistics* 31, 393–9.
- (1996a). Review of Bauer 1995. *Language* 72(1), 156–9.
- (1996b). Catastrophic change and learning theory. *Lingua* 100. [50th anniversary issue.]
- (1997). Shifting triggers and diachronic reanalyses. In van Kemenade and Vincent 1997 (pp. 253–72).
- (1999a). *The Development of Language: Acquisition, Change, and Evolution*. Oxford: Blackwell. (Blackwell/Maryland Lectures in Cognition, 1.)
- (1999b). Creoles and cues. In De Graff 1999b (pp. 431–52).

- Lightfoot, David W. and Hornstein, Norbert (eds) (1994). *Verb Movement*. Cambridge: Cambridge University Press.
- Lightner, Theodore (1975). The role of derivational morphology in generative grammar. *Language* 51, 617–38.
- Lindblom, Björn (1963). Spectrographic study of vowel reduction. *Journal of the Acoustical Society of America* 35(11), 1773–81.
- Lindblom, B., Guion, S., Hura, S., Moon, S.-J., and Willerman, R. (1995). Is sound change adaptive? *Rivista di Linguistica* 7, 5–37.
- Lindeman, Fredrik Otto (1970). *Einführung in die Laryngalthorie* [written in collaboration with Carl Hj. Borgstrøm]. Berlin: Walter de Gruyter. (Sammlung Götschen, 1247–7a.) [Trans. and rev. by the author as *Introduction to the "Laryngeal Theory"*. Oslo: Norwegian University Press and Institute for Comparative Research in Human Culture, distributed outside Scandinavia by Oxford University Press, 1987.]
- Lloyd, Paul M. (1987). *From Latin to Spanish, Volume 1: Historical Phonology and Morphology of the Spanish Language*. Philadelphia, PA: American Philosophical Society. (Memoirs of the American Philosophical Society, 173.)
- (1998). La historia y la gramática histórica. In Claudio García Turza, Fabián González Bachiller, and Javier Mangado Martínez (eds), *Actas del 4. Congreso Internacional de Historia de la Lengua Española; La Rioja, 1–5 de abril de 1997* (pp. 77–90). Logroño: Servicio de Publicaciones, Universidad de la Rioja.
- Löfqvist, Anders, Baer, Thomas, McGarr, Nancy S., and Seider Story, Robin (1989). The cricothyroid muscle in voicing control. *Journal of the Acoustical Society of America* 85(3), 1314–21.
- Löfstedt, Bengt (1963). Zum lateinischen possessiven Dativ. *Zeitschrift für vergleichende Sprachforschung auf dem Gebiete der Indogermanischen Sprachen* 78, 64–83.
- Lord, Carol Diane (1993). *Historical Change in Serial Verb Constructions*. Amsterdam: John Benjamins. (TSL 26.)
- Lorentz, Hendrik Antoon, Einstein, Albert, Minkowski, Hermann[, and Weyl, Hermann] (1922). *Das Relativitätsprinzip: eine Sammlung von Abhandlungen*. Leipzig: B. G. Teubner. (Fortschritte der mathematischen Wissenschaften in Monographien, 2.) [4th, expanded edn; 1st edn, 1913, without Weyl's contribution. Repr. Stuttgart 1982.] [Transl. W. Perrett and George Barker Jeffery as *The Principle of Relativity: A Collection of Original Memoirs . . . on the Special and General Theory of Relativity*. London: Methuen, 1923. Repr. New York: Dover, 1952.]
- Losos, Jonathan B., Warheit, K. I., and Schoener, Thomas W. (1997). Adaptive differentiation following experimental island colonization in *Anolis* lizards. *Nature* 387, 70–3.
- Lowenthal, David (1985). *The Past Is a Foreign Country*. Cambridge: Cambridge University Press. [Repr. 1993.]
- Lucretius Carus, Titus (c.60 BC). *De rerum natura libri sex*. Manuscript. [Ed. and transl. Cyril Bailey as *De rerum natura 1: Prolegomena, text, and critical apparatus; translation; 2: Commentary, books 1–3*, Oxford: Clarendon Press, 1947. Reissued 1986.]
- Lumsden, Charles J. and Wilson, Edward Osborne (1981). *Genes, Mind, and Culture: The Coevolutionary Process*. Cambridge, MA: Harvard University Press.
- (1982). Genes, mind, and ideology. *Sciences* 21(9), 6–8.
- (1983). *Promethean Fire: Reflections on the Origin of Mind*. Cambridge, MA: Harvard University Press.
- Lund, Niels (ed.) (1984). *Two Voyagers at the Court of King Alfred: The Ventures of Othhere and Wulfstan, Together with the Description of Northern Europe, from the Old English Orosius* [transl. Christine E. Fell], with *Contributory Essays* [by Ole Crumlin-Pedersen,

- P. H. Sawyer, and Christine E. Fell]. York: W. Sessions. [Transl. based on text ed. Janet Bately as *The Old English Orosius*, London: Oxford University Press, for the Early English Text Society, 1980. (SS [Early English Text Society], 6.)]
- Luschützky, Hans-Christian (1991). *Twenty Years of Naturalism in Linguistics: A Bibliography*. Vienna: Institut für Sprachwissenschaft.
- Lyell, Charles (1830–3). *Principles of Geology, Being an Attempt to Explain the Former Changes of the Earth's Surface by Reference to Causes Now in Operation. Volumes I–III*. London: John Murray. [5th and last edn, 1837. Repr. New York: Readex Microprint, 1967. (Landmarks of Science.) Repr., ed. Martin J. S. Rudwick, Chicago: University of Chicago Press, 1990–1. Ed. James A. Secord, London: Penguin, 1997.]
- Lyell, Katherine M. (ed.) (1881). *Life, Letters, and Journals of Sir Charles Lyell, Bar[one]t, Volumes 1–2*. London: John Murray. [Repr. New York: Readex Microprint, 1970. (Landmarks of Science.)]
- Lyons, John (1977). *Semantics*. Cambridge: Cambridge University Press.
- Mabbott, J. D. (1951). Our direct experience of time. *Mind* 60, 153–67. [Repr. in Gale 1967 (pp. 304–21).]
- Macaulay, David (1979). *Motel of the Mysteries*. Boston: Houghton Mifflin.
- MacBeath, Murray (1982). Who was Dr. Who's father? *Synthèse* 51, 397–430.
- Machamer, Peter, Pera, Marcello, and Baltas, Arist(e)ides (eds) (2000). *Scientific Controversies: Philosophical and Historical Perspectives*. New York: Oxford University Press.
- Mackie, Penelope J. (1995). Event. In Honderich 1995 (pp. 253–4).
- Maclagan, Margaret and Gordon, Elizabeth (1996). Out of the AIR and into the EAR: another view of the New Zealand diphthong merger. *Language Variation and Change* 8(1), 125–47.
- Madvig, Johan Nicolai (1842). *Første Stykke af en Afhandling om Sprogets Væsen, Udvikling og Liv. Kjøbenhavns Universitets Festskrift*. [Transl. by the author as “Über Wesen, Entwicklung und Leben der Sprache, 1. Stück,” in *Kleine philologische Schriften* (pp. 48–97), Leipzig: Teubner, 1875. Repr. Hildesheim: Georg Olms, 1966. Repr. in *Sprachtheoretische Abhandlungen*, ed. Karsten Johansen (pp. 81–116), Copenhagen: Ejnar Munksgaard, 1971.]
- Maguran, Anne E. and May, Robert McCredie (eds) (1999). *Evolution of Biological Diversity*. Oxford: Oxford University Press.
- Maiden, Martin (1991). *Interactive Morphology: Metaphony in Italy*. London: Routledge.
- Malkiel, Yakov (1953). Language history and historical linguistics. *Romance Philology* 7(1), 65–76.
- (1955). Etymology and historical grammar. *Romance Philology* 8(3), 187–208.
- (1957). Diachronic hypercharacterization in Romance. *Archivum linguisticum* 9, 79–113; 10, 1–36.
- (1959). Necrology: Karl Jaberg. *Romance Philology* 12(3), 258–61.
- (1967). Each word has a history of its own. *Glossa* 1(2), 137–49. [Repr. in his *From Particular to General Linguistics: Selected Essays 1965–1978* (pp. 217–26), Amsterdam: John Benjamins. (Studies in Language Companion Series, 3.)]
- (1968). The inflectional paradigm as an occasional determinant of sound change. In Lehmann and Malkiel 1968 (pp. 21–64).
- (1981). Hypercharacterization of pronominal gender in Romance. In T. Hope (ed.), *Language, Meaning, and Style: Essays in Memory of Stephen Ullmann* (pp. 91–107). Leeds: Leeds University Press.
- Mallory, J. P. (1989). *In Search of the Indo-Europeans: Language, Archaeology, and Myth*. London: Thames and Hudson.

- Mallory, J. P. and Adams, D. Q. (eds) (1997). *Encyclopedia of Indo-European Culture*. London and Chicago: Fitzroy Dearborn.
- Malone, Joseph L. (1969). Rules of synchronic analogy: a proposal based on evidence from three Semitic languages. *Foundations of Language* 5, 534–59.
- Manaster Ramer, Alexis (1988). The phoneme in generative phonology and phonological change. *Diachronica* 5, 109–39.
- (1994). Comparative syntax. Posting 5.1458, message 1, to LINGUIST (12 December 1994).
- Mańczak, Witold (1958). Tendences générales des changements analogiques. *Lingua* 7, 298–325; 387–420.
- (1966). Fréquence et évolution. In *Statistique et analyse linguistique: Colloque de Strasbourg (20–22 avril 1964)* (pp. 99–103). Paris: Presses Universitaires de France.
- (1978). Les lois du développement analogique. *Linguistics* 205, 53–60.
- (1980). Laws of analogy. In Fisiak 1980 (pp. 283–8).
- Manly, J. (1930). From generation to generation. In N. Bøgholm, A. Brusendorff, and C. Bodelson (eds), *A Grammatical Miscellany Offered to Otto Jespersen on His 70th Birthday [July 16, 1930]* (pp. 287–9). Copenhagen: Levin and Munksgaard.
- Mann, Virginia A. and Repp, Bruno H. (1980). Influence of vocalic context on perception of the [š] versus [s] distinction. *Perception and Psychophysics* 28, 213–28.
- (1981). Perceptual assessment of fricative-stop coarticulation. *Journal of the Acoustical Society of America* 69(4), 1154–63.
- Marks, Jonathan (2000). 98% alike? (What our similarity to apes tells us about our understanding of genetics). *Chronicle of Higher Education* B7.
- Martin, Elizabeth, Ruse, Michael, and Holmes, Elaine (eds) (1996). *A Dictionary of Biology*. 3rd edn. Oxford: Oxford University Press.
- Martinet, André (1952). Function, structure, and sound change. *Word* 8, 1–32.
- (1954). The unity of linguistics. *Word* 10(2–3), 121–5. [Simultaneously in André Martinet and Uriel Weinreich (eds), *Linguistics Today, Published on the Occasion of the Columbia University Bicentennial* (pp. 1–5). New York: Linguistic Circle of New York, 1954. (Publications of the Linguistic Circle of New York, 2.)]
- Mascaró, Joan (1996). External allomorphy and contractions in Romance. *Probus* 8, 181–205.
- Masica, Colin P. (1976). *Defining a Linguistic Area: South Asia*. Chicago: University of Chicago Press.
- Maslova, Elena (1999). Linguistic preferences: language change against historical accidents. Manuscript, University of Bielefeld.
- (2000). A dynamic approach to the verification of distributional universals. *Linguistic Typology* 4(3), 307–33.
- Maspero, Henri (1912). Études sur la phonétique historique de la langue annomite: les initiales. *Bulletin de l'École Française Extrême Orient* 12(1).
- Mathangwane, J. (1996). Phonetics and phonology of Ikalanga: a diachronic and synchronic study. Ph.D. dissertation, University of California, Berkeley.
- Matisoff, James A. (1990). On megal-comparison: a discussion note. *Language* 66(1), 106–20.
- (1999). Genetic versus areal linguistics in Southeast Asia (II): prosodic diffusibility in Southeast Asian languages. Manuscript, University of California, Berkeley.
- Matsumoto, Y. (1988). From bound grammatical markers to free discourse markers: history of some Japanese connectives. In Axmaker et al. 1988 (pp. 340–51).
- Matthews, Peter Hugoe (1993). *Grammatical Theory in the United States from Bloomfield to Chomsky*. Cambridge: Cambridge University Press. (CSL 67.)

- (1994). Greek and Latin linguistics. In Giulio C. Lepschy (ed.), *History of Linguistics. Volume 2: Classical and Medieval Linguistics* (pp. 1–133). London and New York: Longman.
- Maudlin, T. (1990). Time-travel and topology. *Proceedings of the Biennial Meetings of the Philosophy of Science Association* 303–15.
- Maurer, Armand Augustine (1978). Method in Ockham's nominalism. *Monist* 61, 426–43. [Repr. in *Being and Knowing: Studies in Thomas Aquinas and Later Medieval Philosophers* (pp. 403–21), Toronto: Pontifical Institute of Mediaeval Studies [PIMS], 1990. (Papers in Medieval Studies, 10.)]
- (1999). *The Philosophy of William of Ockham in the Light of its Principles*. Toronto: Pontifical Institute of Medieval Studies [PIMS]. (Studies and Texts, 133.)
- Maurer, Friedrich (1926). *Untersuchungen über die deutsche Verbstellung in ihrer geschichtlichen Entwicklung*. Heidelberg: C. Winter.
- Mayerthaler, Willi (1977). *Studien zur theoretischen und zur französischen Morphologie*. Tübingen: Niemeyer.
- (1980a). Analogiebibliographie. *Zeitschrift für französische Sprache und Literatur* 90, 309–20.
- (1980b). Aspekte der Analogietheorie. In Helmut Lüdtke (ed.), *Kommunikationstheoretische Grundlagen des Sprachwandels* (pp. 80–130). Berlin and New York: de Gruyter.
- (1981). *Morphologische Natürlichkeit*. Wiesbaden: Athenaion. [Trans. Janice Siedler as *Morphological Naturalness*, Ann Arbor: Karoma, 1988.]
- Mayerthaler, Willi, Fliedl, Gunther, and Winkler, C. (1994). *Infinitivprominenz in europäischen Sprachen*. Tübingen: Narr.
- Maynard Smith, John (1983). The genetics of stasis and punctuation. *Annual Review of Genetics* 17, 1125.
- Mayr, Ernst (1942). *Systematics and the Origin of Species from the Viewpoint of a Zoologist*. New York: Columbia University Press. [Repr. New York: Dover, 1964.]
- (1947). Ecological features in speciation. *Evolution* 1, 263–88.
- (1954). Change of genetic environment and evolution. In Julian Sorell Huxley, (Sir) Alister Clavering Hardy, and Edmund Briscoe Ford (eds), *Evolution as a Process* (pp. 157–80). London: G. Allen and Unwin. [1st edn; 2nd edition, 1958.]
- (ed.) (1957). *The Species Problem*. Washington, DC: American Association for the Advancement of Science [AAAS]. (AAAS Publications, 50.)
- (1963). *Animal Species and Evolution*. Cambridge, MA: Belknap Press of Harvard University Press. [Repr. 1979.]
- (1972). The nature of the Darwinian revolution. *Science* 176, 981–9. [Rev. version repr. in Mayr 1976 (pp. 277–96). Sometimes cited by Mayr himself as 1971.]
- (1976). *Evolution and the Diversity of Life: Selected Essays*. Cambridge, MA: Belknap Press of Harvard University Press.
- (1982). *The Growth of Biological Thought: Diversity, Evolution, and Inheritance*. Cambridge, MA: Belknap Press of Harvard University Press.
- (1997). *This Is Biology: The Science of the Living World*. Cambridge, MA: Belknap Press of Harvard University Press. [7th pr. 1999.]
- Mazzuoli Porru, G. (ed.) (1980). *Nuovi metodi e problemi nella linguistica storica: atti del Convegno della Società Italiana di Glottologia; Firenze, 25 e 26 ottobre 1979*. Pisa: Giardini.
- McCrum, Robert, Cran, William, and MacNeil, Robert (1986). *The Story of English*. New York: Viking.
- McIntosh, Roderick J. (1996). History of archaeology, intellectual. In Fagan 1996 (pp. 280–5).

- McLeish, Kenneth (1996). Editor's introduction. In Robert Graves, *The Greek Myths*, ed. Kenneth McLeish (pp. 11–20). London: Folio Society.
- McLemore, Cynthia (1991). The pragmatic interpretation of English intonation: sorority speech. Ph.D. dissertation, University of Texas.
- McMahon, April M. S. (1994a). *Understanding Language Change*. Cambridge: Cambridge University Press.
- (1994b). On the use of the past to explain the present: the history of /r/ in English and Scots. In Derek Britton (ed.), *English Historical Linguistics 1994: Papers from the 8th International Conference on English Historical Linguistics (8. ICEHL, Edinburgh, 19–23 September 1994)* (pp. 73–89). Amsterdam: John Benjamins. (CILT 135.)
- (2000a). The emergence of the optimal?: Optimality theory and sound change. *Linguistic Review* 17(2–4), 231–40.
- (2000b). *Change, Chance, and Optimality*. Oxford: Oxford University Press.
- McTaggart, John McTaggart Ellis (1908). The unreality of time. *Mind* (n.s.) 68, 457–74.
- McWhorter, John (1998). Identifying the creole prototype. *Language* 74(4), 788–818.
- Meiland, Jack W. (1974). A two-dimensional passage model of time for time travel. *Philosophical Studies* 26, 153–73.
- Meillet, Antoine (1904–5). Comment les mots changent de sens. *L'année sociologique* 9, 1–38 [mislabelled “1905–1906”]. [Repr. in Meillet 1948 (pp. 230–71).]
- (1912). L'évolution des formes grammaticales. *Scientia (Rivista di Scienze)* 12(26), 6. [Repr. in Meillet 1948 (pp. 130–48).]
- (1914). Le problème de la parenté des langues. *Scientia (Rivista di Scienze)* 15(35), 3. [Repr. in Meillet 1948 (pp. 76–101).]
- (1923). Le développement du verbe “avoir.” In *Festschrift Jacob Wackernagel zur Vollendung des 70. Lebensjahres* (pp. 9–13). Göttingen: Vandenhoeck and Ruprecht.
- (1925). *La méthode comparative en linguistique historique*. Paris: Édouard Champion. [Trans. Gordon B. Ford, Jr, as *The Comparative Method in Historical Linguistics*, Paris: Édouard Champion, 1967.]
- (1929). Le développement des langues. In *Continu et discontinu* (pp. 119ff). Paris: Bloud et Gay. [Repr. in Meillet 1948 (pp. 70–83).]
- (1930). *Caractères généraux des langues germaniques*. 4th edn. Paris: Librairie Hachette.
- (1948). *Linguistique historique et linguistique générale*. Paris: Édouard Champion. (Société de Linguistique de Paris, Collection Linguistique, 8.)
- (1964). *Introduction à l'étude comparative des langues indo-européennes*. Reprint. University, AL: University of Alabama Press. [8th edn; 1st edn 1903.]
- Meillet, Antoine and Cohen, Marcel (1924). *Les langues du monde*. Paris: Édouard Champion.
- Melchert, H. Craig (1975). “Exceptions” to exceptionless sound laws. *Lingua* 35, 135–53.
- Melis, E. (1989). Grundlagen von Analogiebildung: zu Perspektiven ihrer Rechnerstützung. *Communication and Cognition* 22, 87–110.
- Mellor, D. Hugh (1981). *Real Time*. Cambridge: Cambridge University Press.
- (1991). Causation and the direction of time. *Erkenntnis* 35, 191–203.
- (1998). *Real Time 2*. London: Routledge. (International Library of Philosophy.)
- Méndez Dosuna, Julián (2000). Review of Geoffrey Horrocks, *Greek: A History of the Language and its Speakers*. *Journal of Greek Linguistics* 1, 274–95.
- Méndez Dosuna, Julian and Pensado, Carmen (1990). How unnatural is Spanish *Víctor*→*Vict-ít-or*? In Julian Méndez Dosuna and Carmen Pensado (eds), *Naturalists at Krems* (pp. 89–106). Salamanca: Acta Salmanticensia.
- Mendoza-Denton, Norma Catalina (1994). Concerning NP constructions. Paper presented at the Annual Meeting of the Linguistic Society of America, New York, January.

- (1998). English grammaticalization from verb to preposition: the case of *concerning* NP. Paper presented at the Annual Meeting of the Linguistic Society of America, New York.
- Menéndez Pidal, Ramón (1926). *Orígenes del español*. Madrid: Hernando.
- (1966). *Manual de gramática histórica española*. 12th edn. Madrid: Espasa-Calpe.
- Menn, Lise and MacWhinney, Brian (1984). The repeated morph constraint: toward an explanation. *Language* 60(3), 519–41.
- Metzger, Bruce M. and Coogan, Michael D. (eds) (1993). *The Oxford Companion to the Bible*. New York: Oxford University Press.
- Meyer, E. A. (1896–7). Zur Tonbewegung des Vokals im gesprochenen und gesungenen Einzelwort. *Phonetische Studien* 10(n.s. 4), 1–21.
- Milius, Susan (2000). Botany under the mistletoe: twisters, spitters, and other flowery thoughts for romantic moments. *Science News* 158(26/27), 411–13.
- Miller, James D. (1989). Auditory-perceptual interpretation of the vowel. *Journal of the Acoustical Society of America* 85(5), 2114–34.
- Miller, Sarah Bryan (1995). What's new in Ancient Egypt?: q[uestions] and a[nswers] with U[niversity] of C[hicago] scholar Emily Teeter. *Chicago Reader* 24.42 (July 21), section 1: 8–9, 20, 25–6.
- Milroy, James (1992). *Linguistic Variation and Change*. Oxford: Blackwell.
- (1993). On the social origins of language change. In C. Jones 1993 (pp. 215–36).
- (1999). Toward a speaker-based account of language change. In Jahr 1999 (pp. 21–36).
- Milroy, James and Milroy, Leslie (1985). Linguistic change, social network and speaker innovation. *Journal of Linguistics* 21, 339–84.
- Milroy, Leslie (1980). *Language and Social Networks*. Baltimore, MD: University Park Press.
- (1987). *Observing and Analysing Natural Language*. Oxford: Blackwell.
- Milroy, Leslie and Milroy, James (1992). Social network and social class: toward an integrated sociolinguistic model. *Language in Society* 28(1), 1–26.
- Minkowski, Hermann (1908). Raum und Zeit. (Lecture given at the 80. Versammlung deutscher Naturforscher und Ärzte, Cologne, September 21.) [Pub. 1909. Repr. in Lorentz et al. 1922 (pp. 54–66, with “Anmerkungen” by A. Sommerfeld, pp. 67–71) and repr. 1982 (pp. 73–91, 92–6) in its 1923 trans. as “Space and time” by W. G. Perrett and G. B. Jeffery (repr. again 1952).]
- Miranda, Rocky V. (1974). Analogy and leveling. In *Mid-America Linguistics Conference Papers, 1973*. Iowa City: Department of Linguistics, University of Iowa.
- Mish, Frederick C. et al. (eds) (1997). *Merriam-Webster's Collegiate Dictionary*. 10th edn. Springfield, MA: Merriam-Webster. [1st pr. 1993.]
- Mitchell, B. (1985). *Old English Syntax*. Vols 1–2. Oxford: Clarendon Press.
- Mithun, Marianne (1984). Levels of linguistic structure and the rate of change. In J. Fisiak (ed.), *Historical Syntax* (pp. 301–32). Berlin: Mouton.
- (1988). The grammaticalization of coordination. In Haiman and Thompson 1988 (pp. 331–59).
- (1989). Historical linguistics and linguistic theory: reducing the arbitrary and constraining explanation. *BLS* 15, 391–408.
- (1990). Studies of North American Indian languages. *Annual Review of Anthropology* 9, 309–30.
- (1992). External triggers and internal guidance in syntactic development: coordinating conjunction. In Marinel Gerritsen and Dieter Stein (eds), *Internal and External Factors in Syntactic Change* (pp. 89–129). Berlin: Mouton. (Trends in Linguistics 61.)

- (1994). The implications of ergativity for a Philippine voice system. In Barbara Fox and Paul L. Hopper (eds), *Voice: Its Form and Function* (pp. 247–77). Amsterdam: John Benjamins.
- Mohanan, K. P. (1991). On the bases of radical underspecification. *Natural Language and Linguistic Theory* 9, 285–325.
- Mommsen, Hans (1987). Flight from reality: Hitler as party leader and dictator in the Third Reich. *Syracuse Scholar* 8(1), 51–9.
- Montelius, Oscar (1899). Typologien eller utvecklingsläran tillämpad på det menliga arbetet. *Svenska fornminnesföreningens tidskrift* 10(3), 237–68.
- Moon, Seung-Jae and Lindblom, Björn (1994). Interaction between duration, context, and speaking styles in English stressed vowels. *Journal of the Acoustical Society of America* 96(1), 40–55.
- Moonwomon, Birch (1992). The mechanism of lexical diffusion. Paper presented at the Annual Meeting of the Linguistic Society of America, Philadelphia.
- Moravcsik, Edith A. (1978). Verb borrowing. In Joseph H. Greenberg (ed.), *Universals of Human Language, Volume 1* (pp. 93–122). Stanford: Stanford University Press.
- (1977). On rules of infixing. Bloomington: University of Indiana Linguistics Club.
- Morin, Yves-Charles (1986). On the morphologization of word-final consonant deletion in French. In Henning Andersen (ed.), *Sandhi Phenomena in the Languages of Europe* (pp. 167–210). Berlin: Mouton de Gruyter.
- (1992). Phonological interpretations of historical lengthening. Paper presented at Seventh International Phonology Meeting, Krems.
- Morin, Yves-Charles and Kaye, Jonathan (1982). The syntactic bases for French liaison. *Journal of Linguistics* 18, 291–330.
- Morin, Y.-C., Langlois, M.-C., and Varin, M.-È. (1990). Tensing of word-final [ɔ] to [o] in French: phonologization of a morphophonological rule. *Romance Philology* 43(4), 507–28.
- Morpurgo Davies, Anna (1987). “Organic” and “organism” in Franz Bopp. In Hoenigswald and Wiener 1987 (pp. 81–107).
- (1998). *History of Linguistics. Volume IV: Nineteenth-Century Linguistics*, gen. ed. Giulio Lepschy. London and New York: Longman.
- Morris, Michael, Thorne, Kip, and Yurtsever, U. (1988). Wormholes, time machines, and the Weak Energy Condition. *Physical Review Letters* 61 (September 26), 1446–9.
- Morris, William and Morris, Mary (1977). *Dictionary of Word and Phrase Origin*. New York: Harper and Row.
- Mossé, F. (1952). *A Handbook of Middle English*. Baltimore, MD: Johns Hopkins University Press.
- Moulton, William G. (1960). The short vowel system of Northern Switzerland: a study in structural dialectology. *Word* 16(2), 155–82.
- (1961a). Lautwandel durch innere Kausalität: Die ostschweizerische Vokalspaltung. *Zeitschrift für Mundartforschung* 28, 227–52.
- (1961b). Zur Geschichte des deutschen Vokalsystems. *Beiträge zur Geschichte der deutschen Sprache und Literatur* 83, 1–35.
- Mous, Maarten (1994). Ma’a or Mbugu. In Peter Bakker and Maarten Mous (eds), *Mixed Languages* (pp. 175–200). Amsterdam: Institute for Functional Research into Language and Language Use.
- Mufwene, Salikoko S. (1996). The Founder Principle in creole genesis. *Diachronica* 13(1), 83–134.
- (2001). *The Ecology of Language Evolution*. Cambridge: Cambridge University Press. (Cambridge Approaches to Language Contact.)

- Mühlhäusler, Peter (1990). Creolistics and theoretical linguistics. In R. Ahrends (ed.), *Anglistentag 1989 Würzburg: Proceedings* (pp. 225–34). Tübingen: Niemeyer.
- Müller, M. (1864). *Lectures on the Science of Language*. 2nd series. London: Longman, Roberts, and Green.
- Mundle, C. W. K. (1967). Consciousness of time. In Edwards 1967 (pp. 134–9).
- Munro, H. H. [Saki] (1924). Clovis on the alleged romance of business. [Repr. in *The Complete Works of Saki* (pseudon. H. H. Munro), Garden City: Doubleday, 1988.]
- Murdock, George P. (1959). Cross-language parallels in parental kin terms. *American Linguistics* 1(9), 1–5.
- Murray, James and Clarke, Brian (1980). The genus *Partula* on Moorea: speciation in progress. *Proceedings of the Royal Society of London* 211, 83–117.
- Muysken, Pieter (1981). Halfway between Quechua and Spanish: the case for relexification. In Arnold Highfield and Albert Valdman (eds), *Historicity and Variation in Creole Studies* (pp. 52–78). Ann Arbor: Karoma.
- (1997). Media lengua. In Sarah G. Thomason (ed.), *Contact Languages: A Wider Perspective* (pp. 365–426). Amsterdam and Philadelphia: John Benjamins.
- Muysken, Pieter and Smith, Norval (eds) (1986). *Substrata versus Universals in Creole Genesis*. Amsterdam and Philadelphia: John Benjamins.
- Myers, Scott (1987). Vowel shortening in English. *Natural Language and Linguistic Theory* 5(4), 485–518.
- Myers-Scotton, Carol (1993). *Duelling Languages: Grammatical Structure in Code-Switching*. Oxford: Oxford University Press.
- Nagy, Naomi (1996). Language contact and language change in the Faetar speech community. Ph.D. dissertation, University of Pennsylvania. (IRCS Report 96–08.)
- Nagy, Naomi and Reynolds, Bill (1997). Optimality Theory and variable word-final deletion in Faetar. *Language Variation and Change* 9(1), 37–55.
- Nahin, Paul J. (1997). *Time Travel*. Cincinnati: Writer's Digest Books.
- (1999). *Time Machines: Time Travel in Physics, Metaphysics, and Science Fiction*. 2nd edn. New York: AIP Press, Springer-Verlag New York. [1st edn 1993.]
- Narasimhan, R. (1998). *Language Behaviour: Acquisition and Evolutionary History*. New Delhi: Sage.
- Naro, Anthony J. (1978). A study of the origins of pidginization. *Language* 54(2), 314–64.
- (1981). The social and structural dimensions of a syntactic change. *Language* 57(1), 63–99.
- Naro, Anthony J. and Lemle, Miriam (1976). Syntactic diffusion. In Sanford B. Steever, Carol A. Walker, and Salikoko S. Mufwene (eds), *CLS*, 12, no. 2, *Parasession on Diachronic Syntax* 221–40.
- Naumann, Bernd, Plank, Frans, and Hofbauer, Gottfried (eds) (1992). *Language and Earth: Elective Affinities Between the Emerging Sciences of Linguistics and Geology*. Amsterdam: John Benjamins. (Studies in the History of the Language Sciences, 66.)
- Navarro Tomás, T. (1918). Diferencia de duración entre las consonantes españolas. *Revista de Filología Española* 5, 385–6.
- Negri, Mario and Poli, Diego (eds) (1994). *La semantica in prospettiva diacronica e sincronica: Atti del Convegno della Società Italiana di Glottologia*. Pisa: Giardini Editori e Stampatori.
- Nerlich, Brigitte (ed.) (1989). *Linguistic Evolution*. 77(2). Special issue of *Lingua*.
- (1990). *Change in Language: Whitney, Bréal, and Wegener*. London: Routledge.
- Nevis, Joel A. (1986). Decliticization and deaffixation in Saame: abessive *taga*. In Brian D. Joseph (ed.), *Ohio State University Working Papers in Linguistics* 34, 1–9.
- Newell, Norman Dennis (1967). Revolutions in the history of life. In Albritton 1967a (pp. 63–91).

- Newman, Ezra T., Unti, Theodore, and Tamburino, Louis (1963). Empty-space generalization of the Schwarzschild metric. *Journal of Mathematical Physics* 4(7), 915–23.
- Newman, Paul (1980). *The Classification of Chadic within Afroasiatic*. Leiden: Universitaire Pers.
- Newmeyer, Frederick J. (1986). *Linguistic Theory in America*. Orlando: Academic Press.
- (ed.) (1988). *Linguistics: The Cambridge Survey, I: Linguistic Theory: Foundations*. Cambridge: Cambridge University Press.
- (1994). Can the comparative method be applied to syntax? Posting 5.1370, message 1, to LINGUIST (1 December 1994).
- (1998). *Language Form and Language Function*. Cambridge, MA: MIT Press.
- (2001). Deconstructing grammaticalization. In Campbell 2001b (pp. 187–229).
- Newport, E. L. (1991). Contrasting conceptions of the critical period for language. In S. Carey and R. Gelman (eds), *The Epigenesis of Mind: Essays on Biology and Cognition* (pp. 111–30). Hillsdale, NJ: Lawrence Erlbaum.
- (1999). Reduced input in the acquisition of signed languages: contributions to the study of creolization. In De Graff 1999b (pp. 161–78).
- Newport, E. L., Gleitman, H., and Gleitman, L. R. (1977). Mother, I'd rather do it myself: some effects and non-effects of maternal speech style. In Catherine E. Snow and Charles A. Ferguson (eds), *Talking to Children: Language Input and Acquisition: Papers from a Conference Sponsored by the Committee on Sociolinguistics of the Social Science Research Council (USA)* (pp. 109–50). Cambridge: Cambridge University Press.
- Newton, Isaac (1687). *Philosophiae naturalis principia mathematica*. [Excerpts repr. in *Newton's Philosophy of Nature: Selections from His Writings*, ed. Horace Standish Thayer, New York: Hafner Publishing, 1953. (Hafner Library of Classics, 16.)]
- Nichols, Johanna (1971). Diminutive consonant symbolism in Western North America. *Language* 47(4), 826–48.
- (1984). Functional theories of grammar. *Annual Review of Anthropology* 13, 97–249.
- (1992a). *Linguistic Diversity in Space and Time*. Chicago: University of Chicago Press.
- (1992b). The Caucasus as a linguistic area, 1: personal pronouns. In George Hewitt (ed.), *Caucasian Perspectives* (pp. 343–71). Unterschleissheim and Munich: LINCOM Europa.
- (1993). Ergativity and linguistic geography. *Australian Journal of Linguistics* 13, 39–89.
- (1994a). Lecture series at the First Scandinavian Summer School on Language Diversity, Joensuu, Finland.
- (1994b). Re. 5.936 Sum: time ceiling on the comparative method, Case grammar. Posting 5.1006, message 1, to LINGUIST (19 September 1994).
- (1995). Diachronically stable structural features. In Henning Andersen (ed.), *Historical Linguistics 1993: Papers from the Eleventh International Conference on Historical Linguistics* (pp. 337–56). Amsterdam and Philadelphia: John Benjamins.
- (1996). The comparative method as heuristic. In Durie and Ross 1996 (pp. 39–71).
- (1998). The first four discoveries of America. Presented at AAAS annual meeting, Philadelphia.
- (1999). Why “me” and “thee”? Paper presented at ICHL 14, Vancouver.
- Nichols, Johanna and Peterson, David A. (1996). The Amerind personal pronouns. *Language* 72, 336–71.
- Nichols, Johanna and Timberlake, Alan (1991). Grammaticalization as retextualization. In Traugott and Heine 1991a (pp. 129–46).
- Niebuhr, Reinhold (1952). *The Irony of American History*. New York: Scribner's.

- Nietzsche, Friedrich (1881). *Morgenröte: Gedanken über die moralischen Vorurteile*. [Repr. in *Sämtliche Werke in zwölf Bänden*, Stuttgart: A. Kröner, 1964.]
- Nikiforidou, Kiki (1996). Modern Greek *as*: a case study in grammaticalization and grammatical polysemy. *Studies in Language* 20(3), 599–632.
- Nikolaev, Sergeij L. and Starostin, Sergej A. (1994). *A North Caucasian Etymological Dictionary*. Moscow: Asteriks.
- Niyogi, P. and Berwick, R. C. (1995). The logical problem of language change. MIT, A. I. Memo no. 1516.
- Noble, S. (1985). To have and have got. Paper presented at NWAWE 14, Georgetown University.
- Norde, Muriel (2001). Deflexion as a counterdirectional factor in grammatical change. In Campbell 2001b (pp. 231–64).
- Novikov, Igor Dmitrievich (1998). *The River of Time*. Cambridge: Cambridge University Press. [Trans. Vitaly Kisin from the Russian original *Reka vremën*.]
- Nunberg, Geoffrey, Sag, Ivan A., and Wasow, Thomas (1994). Idioms. *Language* 70(3), 491–538.
- Oaklander, L. Nathan and Smith, Quentin (eds) (1994). *The New Theory of Time*. New Haven: Yale University Press.
- Ohala, J. J. (1974). Experimental historical phonology. In Anderson and Jones 1974b (pp. 353–89).
- (1981a). The listener as a source of sound change. CLS 17, no. 2, *Papers from the Parasession on Language and Behavior* 178–203.
- (1981b). Articulatory constraints on the cognitive representation of speech. In T. Myers, J. Laver, and J. Anderson (eds), *The Cognitive Representation of Speech* (pp. 111–22). Amsterdam: North-Holland.
- (1983a). The phonological end justifies any means. In Shirō Hattori and Kazuko Inoue (eds), *Proceedings of the 13th International Congress of Linguists, Tokyo, 29 Aug.–4 Sept., 1982* (pp. 232–43). Tokyo: Sanseido Shoten.
- (1983b). The origin of sound patterns in vocal tract constraints. In Peter F. MacNeilage (ed.), *The Production of Speech* (pp. 159–216). New York: Springer-Verlag.
- (1985a). Linguistics and automatic speech processing. In Renato De Mori and Ching Y. Suen (eds), *New Systems and Architectures for Automatic Speech Recognition and Synthesis* (pp. 447–75). Berlin: Springer-Verlag.
- (1985b). Around flat. In Victoria Fromkin (ed.), *Phonetic Linguistics: Essays in Honor of Peter Ladefoged* (pp. 223–41). Orlando: Academic Press.
- (1986). Phonological evidence for top-down processing in speech perception. In Joseph S. Perkell and Dennis H. Klatt (eds), *Invariance and Variability in Speech Processes* (pp. 386–97). Hillsdale, NJ: Lawrence Erlbaum.
- (1989). Sound change is drawn from a pool of synchronic variation. In Breivik and Jahr 1989 (pp. 172–98).
- (1991). The integration of phonetics and phonology. *Proceedings of the 12th International Congress of Phonetic Sciences, Aix-en-Provence, 19–24 Aug 1991* 1, 1–16.
- (1992a). What's cognitive, what's not, in sound change. In Kellermann and Morrissey 1992 (pp. 309–55).
- (1992b). Alternatives to the sonority hierarchy for explaining the shape of morphemes. CLS 28, no. 2, *Papers from the Parasession on the Syllable* 319–38.
- (1993a). The phonetics of sound change. In Jones 1993 (pp. 237–78).
- (1993b). Sound change as nature's speech perception experiment. *Speech Communication* 13, 155–61.

- (1995a). A probable case of clicks influencing the sound patterns of some European languages. *Phonetica* 52, 160–70.
- (1995b). Phonetic explanations for sound patterns: implications for grammars of competence. In K. Elenius and P. Branderud (eds), *Proceedings of the 13th International Congress of Phonetic Sciences, Stockholm, 13–19 Aug. 1995* 2, 52–9.
- (1995c). The perceptual basis of some sound patterns. In B. Connell and Amalia Arvaniti (eds), *Papers in Laboratory Phonology IV* (pp. 87–92). Cambridge: Cambridge University Press.
- (1996). The relation between phonetics and phonology. In W. Hardcastle and John Laver (eds), *The Handbook of Phonetics* (pp. 674–94). Oxford: Blackwell.
- (1997). Emergent stops. *Proceedings of the Seoul International Conference on Linguistics* (pp. 89–91). Seoul: Linguistic Society of Korea.
- (forthcoming). Emergent obstruents. In D. Demolin and M. Dominicy (eds), *Studies in Sound Change*. Amsterdam: John Benjamins.
- Ohala, John J. and Busà, M. Grazia (1995). Nasal loss before voiceless fricatives: a perceptually-based sound change. *Rivista di Linguistica* 7, 125–44. Special issue, ed. Carol A. Fowler, *The Phonetic Basis of Sound Change*.
- Ohala, John J. and Feder, D. (1994). Listeners' identification of speech sound is influenced by adjacent "restored" phonemes. *Phonetica* 51, 111–18.
- Ohala, J. J. and Kawasaki-Fukumori, H. (1997). Alternatives to the sonority hierarchy for explaining the shape of morphemes. In S. Eliasson and E. H. Jahr (eds), *Studies for Einar Haugen* (pp. 343–65). Berlin: Mouton.
- Ohala, John J. and Ohala, Manjari (1993). The phonetics of nasal phonology: theorems and data. In Marie K. Huffman and Rena A. Krakow (eds), *Nasals, Nasalization, and the Velum* (pp. 225–49). San Diego: Academic Press.
- Ohala, John J., Bronstein, Arthur J., Busà, M. Grazia, Lewis, Julie A., and Weigel, William F. (eds) (1999). *A Guide to the History of the Phonetic Sciences in the United States: Issued on the Occasion of the 14th International Congress of Phonetic Sciences, San Francisco, 1–7 August 1999*. Berkeley, CA: University of California, Berkeley.
- Öhmann, Emil (1960). Über hyperkorrekte Lautformen. *Annales Academiae Scientiarum Fennicae* ser. B, 123, 1.
- Ohthere and Wulfstan (c.880). [Travelogue before King Alfred of England.] [Old English version ed. Niels Lund, transl. Christine E. Fell, as *Two Voyagers at the Court of King Alfred: The Ventures of Ohthere and Wulfstan, Together with the Description of Northern Europe, from the Old English Orosius . . .*, York: W. Sessions, 1984.]
- Oksaar, E. (1999). Social networks, communicative acts, and the multilingual individual: methodological issues in the field of language change. In Jahr 1999 (pp. 3–19).
- Olive, J. P., Greenwood, A., and Coleman, J. (1993). *Acoustics of American English Speech*. New York: Springer-Verlag.
- Oliveira e Silva, G. (1982). Estudo da regularidade na variação dos possessivas no português do Rio de Janeiro. Ph.D. dissertation, Universidade Federal do Rio de Janeiro.
- Olson, Ronald D. (1964). Mayan affinities with Chipaya of Bolivia I: correspondences. *International Journal of American Linguistics* 30(4), 313–24.
- (1965). Mayan affinities with Chipaya of Bolivia II: cognates. *International Journal of American Linguistics* 31(1), 29–38.
- Onodera, N. O. (1995). Diachronic analysis of Japanese discourse markers. In Jucker 1995 (pp. 393–437).
- Orr, Robert A. (1999). Evolutionary biology and historical linguistics. *Diachronica* 16(1), 123–57.

- Orosius, Paulus (c.600 AD). *Adversus paganos historiarum libri septem*. Manuscript. [Transl. into Old English by command of King Alfred of England, c.880. Ed. Janet Bately as *The Old English Orosius*, London: Oxford University Press, for the Early English Text Society 1980. (SS [Early English Text Society, 6.)]
- Orton, Harold (1962). *Survey of English Dialects*. Leeds: E. J. Arnold (for the University of Leeds).
- Orton, Harold and Halliday, Wilfrid J. (1962). *Survey of English Dialects (B): The Basic Materials. Volume I: The Six Northern Counties and the Isle of Man. Part I*. Leeds: E. J. Arnold for the University of Leeds.
- (1963a). *Survey of English Dialects (B): The Basic Materials. Volume I: The Six Northern Counties and the Isle of Man. Part II*. Leeds: E. J. Arnold (for the University of Leeds).
- (1963b). *Survey of English Dialects (B): The Basic Materials. Volume I: The Six Northern Counties and the Isle of Man. Part III*. Leeds: E. J. Arnold (for the University of Leeds).
- Osborne, C. R. (1974). *The Tiwi Language*. Canberra: Australian Institute of Aboriginal Studies.
- Osgood, Charles and Sebeok, Thomas (1954). Psycholinguistics: a survey of theory and research problems. *Journal of Abnormal and Social Psychology* 49, 1–203.
- Ospovat, Dov (1977). Lyell's theory of climate. *Journal of the History of Biology* 10, 317–39.
- Osthoff, Hermann and Brugman(n), Karl (1878). Preface to *Morphologische Untersuchungen auf dem Gebiete der indogermanischen Sprachen, 1* (pp. iii–xx). [Transl. in Lehmann 1967 (pp. 197–209).]
- Otte, Daniel and Endler, John A. (eds) (1989). *Speciation and its Consequences*. Sunderland, MA: Sinauer Associates.
- Oubouzar, Erika (1974). Über die Ausbildung der zusammengesetzten Verbformen im deutschen Verbalsystem. *Beiträge zur Geschichte der deutschen Sprache und Literatur (Halle)* 95, 5–96.
- Outram, Dorinda (1984). *Georges Cuvier: Vocation, Science, and Authority in Post-Revolutionary France*. Manchester: Manchester University Press.
- Owens, Jonathan (1988). *The Foundations of Grammar: An Introduction to Medieval Arabic Grammatical Theory*. Amsterdam: John Benjamins. (Studies in the History of the Language Sciences, 45.)
- Ozment, Steven (2001). *Ancestors: The Loving Family in Old Europe*. Cambridge, MA: Harvard University Press.
- Page, B. Richard (1999). The Germanic Verschärfung and prosodic change. *Diachronica* 16, 297–334.
- Pagliuca, William (ed.) (1994). *Perspectives on Grammaticalization*. Amsterdam and Philadelphia: John Benjamins. (CILT 109.)
- Pagliuca, William and Mowrey, Richard (1987). Articulatory evolution. In Anna Giacalone Ramat, Onofrio Carruba, and Giuliano Bernini (eds), *ICHL 7* (pp. 459–72). Amsterdam: John Benjamins. (CILT 48.)
- Pallas, Peter Simon (1773–1801). . . . *Reise [1768–1769] durch verschiedene Provinzen des Russischen Reichs . . . , Band 1–3*. St Petersburg: Kayserliche . . . [A]cademie der . . . [W]issenschaften.
- Pangalos, Georgios E. (1955). *Perí tu γλωσικύ ιδιόματος tis krítis*. 2 vols. Athens: by the author.
- Pappas, Panayiotis (1999). From *thelo: graphein/e:thela graphein* to *tha grapho:/tha egrapha*: comparing the development of futures and counter-factuais in Early Modern Greek. *Ohio State University Working Papers in Linguistics* 52. [Rev. version in *Diachronica* 18(2), 2001, 59–92.]

- Paradis, Carole and Prunet, Jean-François (1991). Introduction: asymmetry and visibility in consonant articulations. In Carole Paradis and Jean-François Prunet (eds), *The Special Status of Coronals: Internal and External Evidence* (pp. 1–28). San Diego: Academic Press.
- Pardee, Dennis (1997). Ugaritic. In R. Hetzron (ed.), *The Semitic Languages* (pp. 131–44). London: Routledge.
- Paris, Gaston (1868). Review of Schleicher 1868. *Revue critique d'histoire et de littérature* 6(2), 241–4.
- Parker, Barry R. (1991). *Cosmic Time Travel: A Scientific Odyssey*. New York: Plenum Press.
- Parodi, I. G. (1923). Questioni teoriche: le leggi fonetiche. *NSM* 1, 263–82. [Repr. in *Lingua e letteratura*. Venice: Neri Pozza, 1957.]
- Partridge, Eric and Beale, Paul (eds) (1989). *A Concise Dictionary of Slang and Unconventional English: From a Dictionary of Slang and Unconventional English by Eric Partridge*. New York: Macmillan. [1st American edn.]
- Passy, P. (1890). *Étude sur les changements phonétiques et leurs caractères généraux*. Paris: Firmin-Didot.
- Paul, Hermann (1880). *Prinzipien der Sprachgeschichte*. [2nd edn Halle: Niemeyer, 1886; 5th edn 1920. Repr. Tübingen: Niemeyer, 1970. 2nd edn trans. Herbert Augustus Strong as *Principles of the History of Language*. New York: Macmillan, 1890; 1st edn 1888–9. Repr. College Park, MD: McGrath, 1970.]
- (1891). *Principles of the History of Language*. London.
- (1917). *Deutsche Grammatik. Band II, Teil III: Flexionslehre*. Halle: Niemeyer.
- (1949). *Kurze deutsche Grammatik*. Ed. H. Stolte. Halle: Niemeyer.
- Paul, Hermann, Wiehl, Peter and Grosse, Siegfried (1989). *Mittelhochdeutsche Grammatik*. Tübingen: Niemeyer. [23rd edn; 1st edn, by Paul alone, 1881.]
- Pawley, Andrew K. and Green, R. (1984). The Proto-Oceanic language community. *Journal of Pacific History* 19(3), 123–46.
- Payne, Doris L. (1987). Noun classification in the western Amazon. *Language Sciences* 9(1), 21–44.
- (1992). Introduction. In Doris L. Payne (ed.), *Pragmatics of Word Order Flexibility* (pp. 1–13). Amsterdam: John Benjamins.
- Pearce, Elizabeth (1990). *Parameters in Old French Syntax*. Dordrecht: Kluwer.
- Pedersen, Holger (1924). *Sprogvidenskaben i det Nittende Aarhundrede: Metoder og Resultater*. Copenhagen: Gyldendalske Boghandel. (Det Nittende Aarhundrede, 15.) [Trans. John Webster Spargo as *Linguistic Science in the 19th Century: Methods and Results*. Cambridge, MA: Harvard University Press, 1931. Repr. with the prefaced title *The Discovery of Language . . .* Bloomington, IN: Indiana University Press, 1959, 1962, 4th pr. 1967. (Indiana University Studies in the History and Theory of Linguistics. Midland Books, 40.)]
- Pei, Mario (1952). *The Story of English*. Philadelphia: Lippincott.
- Pierce, C. S. (1965). *Collected Papers*. Cambridge, MA: Harvard University Press.
- Penzl, Herbert (1949). Umlaut and secondary umlaut in Old High German. *Language* 25, 233–40.
- Pérez, A. (1990). Time in motion: the grammaticalisation of the *be going to* construction in English. *La Trobe Working Papers in Linguistics* 3, 49–64.
- Perlmutter, David (1996). Interfaces: explanation of allomorphy and the architecture of grammars. In Steven Lapointe, Diane K. Brentari, and Patrick Farrell (eds), *Morphology and its Relation to Phonology and Syntax* (pp. 307–38). Stanford: CSLI Publications.
- Péronnet, Louise (1989). La question du genre dans le parler acadien du Sud-Est du Nouveau-Brunswick. In Raymond Mougeon and Édouard Beniak (eds), *Le français canadien parlé hors Québec: Aperçu sociolinguistique* (pp. 213–26). Québec: Les Presses

- de l'Université Laval. (Langue française au Québec, 1ère section: Monographies linguistiques, 10.)
- Peterson, Gordon E. (1951). The phonetic value of vowels. *Language* 27(4), 541–53.
- Pfaff, Carol (1979). Constraints on language mixing: intrasentential code-switching and borrowing in Spanish/English. *Language* 55(2), 291–318.
- Phillips, Betty (1980). Old English *an-on*: a new appraisal. *Journal of English Linguistics* 14, 20–3.
- (1984). Word frequency and the actuation of sound change. *Language* 60(2), 320–47.
- Picard, Marc (1994). *Principles and Methods in Historical Phonology: From Proto-Algonkian to Arapaho*. Montreal: McGill-Queen's University Press.
- Pickett, J. M. and Decker, L. R. (1960). Time factors in perception of a double consonant. *Language and Speech* 3, 11–17.
- Pickett, Joseph P. et al. (eds) (2000). *The American Heritage Dictionary of the English Language*. Boston, MA: Houghton Mifflin.
- Pickett, LaSalle (1908). My soldier. *McClure's Magazine* 30(5), 563–71.
- Pickover, Clifford A. (1998). *Time: A Traveler's Guide*. New York: Oxford University Press.
- Pierce, Joe E. (1965). The validity of genetic linguistics. *Linguistics* 13(1), 25–33.
- Pinker, Steven (1994). *The Language Instinct: How the Mind Creates Language*. New York: Morrow.
- Pintzuk, Susan (1990). Phrase structures in competition: variation and change in Old English word order. Ph.D. dissertation, University of Pennsylvania.
- (1993). Verb seconding in Old English: verb movement to Infl. *Linguistic Review* 10, 5–35.
- (1995/1996a). Variation and change in Old English clause structure. *Language Variation and Change* 7(2), 229–60.
- (1996b). Old English verb–complement word order and the change from OV to VO. *York Papers in Linguistics* 17, 241–64.
- (1998a). Post-verbal complements in Old English. In Hogg and van Bergen 1998 (pp. 233–46).
- (1998b). From OV to VO in the history of English. Manuscript, University of York.
- (1999). *Phrase Structures in Competition: Variation and Change in Old English Clause Structure*. New York: Garland.
- Pintzuk, Susan and Kroch, Anthony S. (1989). The rightward movement of complements and adjuncts in the Old English of *Beowulf*. *Language Variation and Change* 1, 115–43.
- Plag, Ingo (1992). From speech act verb to conjunction: the grammaticalization of *taki* in Sranan. *Journal of Pidgin and Creole Languages* 7(1), 55–73.
- (1993). *Sentential Complementation in Sranan: On the Formation of an English-Based Creole Language*. Tübingen: Niemeyer.
- (2002). On the role of grammaticalization in creolization. In Gilbert 2002 (pp. 227–46).
- Plank, Frans (1981). *Morphologische (Ir-)Regularitäten*. Tübingen: Narr.
- (1998). The covariation of phonology with morphology and syntax: a hopeful history. *Linguistic Typology* 2, 195–230.
- Platnick, Norman I. and Cameron, H. Don (1977). Cladistic methods in textual, linguistic, and phylogenetic analysis. *Systematic Zoology* 26(4), 380–5.
- Plato (c.385 BC). *Krátýlos [Cratylus]*. [Trans. Harold N. Fowler as the first part of *Cratylus, Parmenides, Greater Hippias, Lesser Hippias*. London: William Heinemann, 1926. Repr. 1977. (Loeb Classical Library, L166: Plato, vol. 166.)]

- Plauché, M., Delogu, C., and Ohala, John J. (1997). Asymmetries in consonant confusions. *Proceedings, Eurospeech 97, Rhodes, Greece, 22–25 Sept. 1997*, 2187–90.
- Playfair, John (1802). *Illustrations of the Huttonian Theory of the Earth*. Edinburgh: William Creech; London: Cadell and Davies. [Partial repr. in Albritton 1975 (pp. 53–97).]
- Plog, Fred T. (1973). Diachronic anthropology. In Charles L. Redman (ed.), *Research and Theory in Current Archeology* (pp. 181–98). New York: John Wiley and Sons.
- Pollard, Carl and Sag, Ivan (1987). *Information-Based Syntax and Semantics*. Chicago: University of Chicago Press. (CSLI Lecture Notes, 13.)
- Pollock, Jean-Yves (1989). Verb movement, UG, and the structure of IP. *Linguistic Inquiry* 20(3), 365–424.
- Polomé, Edgar C. (ed.) (1990). *Research Guide on Language Change*. Berlin and New York: Mouton de Gruyter. (TIL 48.)
- Polybius (c.150 BC). Liber xvi [fragmenta]. In *Historiae, c.135 BC*. [Trans. William Roger D. Paton as “Fragments of book XVI” in *The Histories. Vol. 5* (pp. 2–83). London: William Heinemann, 1927. (Loeb Classical Library, L159: Polybius, vol. 5.)]
- Pope, M. K. (1934). *From Latin to Modern French, with Especial Consideration of Anglo-Norman*. Manchester: Manchester University Press.
- Poplack, Shana and Tagliamonte, Sali (1996). Nothing in context: variation, grammaticization and past time marking in Nigerian Pidgin English. In Baker and Suya 1996 (pp. 71–94).
- Popper, Karl Raimund (1961). *The Poverty of Historicism*. 3rd edn. London: Routledge and Kegan Paul. [1st edn, 1957. 2nd edn, 1960. Repr. New York: Harper and Row, 1964.]
- Porter, Roy (1976). Charles Lyell and the principles of the history of geology. *British Journal for the History of Science* 9, 91–103.
- Portolés, José (1996). Ramón Menéndez Pidal. In Stammerjohann et al. 1996 (pp. 626–7).
- Poser, William (1982). Phonological representations and action-at-a-distance. In Harry van der Hulst and Norval Smith (eds), *The Structure of Phonological Representations* (vol. 2, pp. 121–58). Dordrecht: Foris.
- Posner, Rebecca (1985). Non-agreement on Romance disagreements. *Journal of Linguistics* 21(2), 437–51.
- (1997). *The Romance Languages*. Cambridge: Cambridge University Press.
- Postal, Paul M. (1968). *Aspects of Phonological Theory*. New York: Harcourt and Brace. [Chs 10 and 11 repr. in Keiler 1972.]
- Powell, Mava Jo (1992). The systematic development of correlated interpersonal and metalinguistic uses in stance adverbs. *Cognitive Linguistics* 3(1), 75–110.
- Press, Ian (1986). *A Grammar of Breton*. Berlin: Mouton de Gruyter.
- Price, Huw (1996). *Time’s Arrow and Archimedes’ Point: New Directions for the Physics of Time*. New York: Oxford University Press. [Paperback edn, 1997.]
- Priestley, L. (1955). Reprise constructions in French. *Archivum Linguisticum* 7, 1–28.
- Prince, Alan and Smolensky, Paul (1993). *Optimality Theory: Constraint Interaction in Generative Grammar*. Technical Reports, Rutgers University Center for Cognitive Science 2.
- Prokosch, Eduard (1939). *A Comparative Germanic Grammar*. Philadelphia: Linguistic Society of America and University of Pennsylvania. [Repr. 1960.]
- Prothero, Donald R. (1998). *Bringing Fossils to Life: An Introduction to Paleobiology*. Boston, MA: WCB / McGraw-Hill.
- Provine, William B. (1986). *Sewall Wright and Evolutionary Biology*. Chicago: University of Chicago Press. (Science and its Conceptual Foundations.)

- Psicharis, Jean (1884). *Essai de phonétique néo-grecque: futur composé du grec moderne*. Paris: Imprimerie Nationale.
- Pütz, Martin (ed.) (1994). *Language Contact and Language Conflict*. Amsterdam and Philadelphia: John Benjamins.
- Pyles, Thomas and Algeo, John (1982). *The Origins and Development of the English Language*. Orlando: Harcourt Brace Jovanovich. [3rd edn; 1st edn, by Pyles alone, 1964.]
- Queen, Robin Michelle (1996). Intonation in contact: a study of Turkish–German bilingual intonation patterns. Ph.D. dissertation, University of Texas.
- Quilis, A. (1970). El elemento esvarabático en los grupos [pr, br, tr]. In *Phonétique et Linguistique Romaines: Mélanges offerts à M. Georges Straka* (pp. 99–104). Lyons and Strasbourg: Société de Linguistique Romane.
- Quintero, Carolyn F. (1998). Osage phonology and verbal morphology. Doctoral dissertation, University of Massachusetts, 1997. (Ann Arbor: University Microfilms International.)
- Ramat, Anna Giacalone and Hopper, Paul J. (eds) (1998). *The Limits of Grammaticalization*. Amsterdam and Philadelphia: John Benjamins.
- Ramat, Paolo (1987). Introductory paper. In Martin Harris and Paolo Ramat (eds), *Historical Development of Auxiliaries* (pp. 3–19). Berlin: Mouton. (TIL 35.)
- (1992). Thoughts on degrammaticalization. *Linguistics* 30, 549–60.
- Rankin, Robert L. (1992). Review of Greenberg 1987. *International Journal of American Linguistics* 58, 324–51.
- (1994). On the sources and scope of Siouan aspiration. In Jule Gomez de Garcia and David S. Rood (eds), *Proceedings of the 1993 Mid America Linguistics Conference* (pp. 205–16.) Boulder: University of Colorado Department of Linguistics.
- Rankin, Robert L., Carter, Richard T., and Jones, A. Wesley (1998). Proto-Siouan phonology and morphology. In Tom Stroik et al. (eds), *Proceedings of the 1997 Mid America Linguistics Conference*. Columbia: University of Missouri Linguistics Program.
- Ransom, Evelyn N. (1988). The grammaticalization of complementizers. *BLS* 14, 364–74.
- Rapp, K. M. (1836). *Versuch einer Physiologie der Sprache, nebst historischer Entwicklung der abendländischen Idiome nach physiologischen Grundsätzen*. Stuttgart: Cotta.
- Rask, Rasmus (1818). *Undersøgelse om det gamle Norske eller Islandske Sprogs Oprindelse*. Copenhagen: Gyldendal.
- Rathje, William L. (1974). The Garbage Project: a new way of looking at the problems of archaeology. *Archaeology* 27(4), 236–41.
- (1977). In praise of archeology: le Projet du Garbàge. In Leland Ferguson (ed.), *Historical Archaeology and the Importance of Material Things: Papers of the Thematic Symposium, 8th Annual Meeting of the Society for Historical Archaeology; Charleston, South Carolina; January 7–11, 1975. Society for Historical Archaeology, Special Publications* 2, 36–42.
- (1978). Le Projet du Garbàge 1975: historic trade-offs. In Redman et al. 1978 (pp. 373–9).
- Rauch, Irmengard (1990). Evidence of language change. In Polomé 1990 (pp. 37–69).
- Raup, David M. (1986). *The Nemesis Affair: A Story of the Death of Dinosaurs and the Ways of Science*. New York: Norton. [Paperback edn, 1987. Rev. and expanded edn, 1999.]
- Raup, D. M. and Jablonski, D. (1986). *Patterns and Processes in the History of Life. Report of the Dahlem Workshop on Patterns and Processes in the History of Life, Berlin, June 16–21, 1985*. Berlin and New York: Springer-Verlag.

- Reardon, Carol (1997a). "I think the Union army had something to do with it": the Pickett's Charge nobody knows. In G. Boritt (ed.), *The Gettysburg Nobody Knows* (pp. 122–43, 237–42, 259–61). New York: Oxford University Press.
- (1997b). *Pickett's Charge in History and Memory*. Chapel Hill: University of North Carolina Press.
- Redman, Charles L., Berman, Mary Jane, Curtin, Edward V., Langhorne, Jr., William T., Versaggi, Nina M., and Wanser, Jeffery C. (eds) (1978). *Social Archeology: Beyond Subsistence and Dating*. New York: Academic Press. (Studies in Archeology.)
- Rees, Nigel (1993). *Epitaphs: A Dictionary of Grave Epigrams and Memorial Eloquence*. London: Bloomsbury.
- Reichenbach, Hans (1928). *Philosophie der Raum-Zeit-Lehre*. Berlin: Walther de Gruyter. [Trans. Maria Reichenbach and John Freund as *The Philosophy of Space and Time*. New York: Dover Publications, 1958. Previously pub. 1957.]
- Reicke, Bo (1993). Early Christian chronology. In Metzger and Coogan 1993 (pp. 119–21).
- Renfrew, Colin (1987). *Archaeology and Language: The Puzzle of Indo-European Origins*. Cambridge: Cambridge University Press.
- Renfrew, Colin and Bahn, Paul (2000). *Archaeology: Theories, Methods, and Practice*. New York: Thames and Hudson.
- Renfrew, Colin, McMahon, April, and Trask, Larry (eds) (2000). *Time Depth in Historical Linguistics*. Cambridge: McDonald Institute for Archaeological Research.
- Reynolds, William (1994). Variation and phonological theory. Ph.D. dissertation, University of Pennsylvania.
- Reznick, David N., Shaw, F. H., Rodd, Frieda Helen, and Shaw, R. G. (1977). Evaluation of the rate of evolution in natural populations of guppies (*Poecilia reticulata*). *Science* 275, 1934–7.
- Riad, Tomas (1992). *Structures in Germanic Prosody*. Stockholm: Department of Scandinavian Languages, Stockholm University.
- Rice, Keren (1989). *A Grammar of Slavey*. Berlin: Mouton de Gruyter.
- Rich, Edwin Ernest (1950). The population of Elizabethan England. *Economic History Review* (2nd Ser.) 2, 247–65.
- Richards, Brian J. (1990). *Language Development and Individual Differences: A Study of Auxiliary Verb Learning*. Cambridge: Cambridge University Press.
- Richardson, James Daniel (ed.) (1897). *A Compilation of the Messages and Papers of the Presidents, 1789–1897. Vol. 6: 1861–1869*. Washington, DC: Government Printing Office. (Published by authority of Congress.) [Also issued as *House Miscellaneous Document No. 210, 53rd Congress, 2nd Session*. Rev. version New York: Bureau of National Literature, 1910ff.]
- Rickard, Peter (1959). The rivalry of *m(a)*, *t(a)*, *s(a)* and *mon*, *ton*, *son* before feminine nouns in Old and Middle French. *Archivum Linguisticum* 11(1), 27–47, 11(2), 115–45.
- Rickford, John (1986). Social contact and linguistic diffusion. *Language* 62(2), 245–90.
- Ridley, Mark (1996). *Evolution*. Boston, MA: Blackwell Scientific Publications. [2nd edn; 1st edn, 1993.]
- (ed.) (1997). *Evolution*. Oxford: Oxford University Press. (Oxford Readers.)
- Riduejo Alonso E. (1989). *Las estructuras gramaticales desde el punto de vista histórico*. Madrid: Síntesis.
- Ringe, Donald A., Jr. (1989). Doric *isanti*. *Münchener Studien zur Sprachwissenschaft* 50, 123–58.
- (1992). On calculating the factor of chance in language comparison. *Transactions of the American Philosophical Society* 82(1), 1–110.

- Rissanen, Matti, Kytö, Merja, and Palander-Collin, Minna (eds) (1993). *Early English in the Computer Age: Explorations through the Helsinki Corpus*. Berlin: Mouton de Gruyter. (Trends in English Linguistics, 11.)
- Ritt, Nikolaus (1994). *Quantity Adjustment: Vowel Lengthening and Shortening in Early Middle English*. Cambridge: Cambridge University Press.
- (1995). Language change as evolution: looking for linguistic “genes.” *Vienna English Working Papers [VIEWS]* 41(1), 43–56.
- Rivart, St George. (1871). *Genesis of Species*. London: Macmillan.
- Rivierre, Jean-Claude (1991). Loss of final consonants in the north of New Caledonia. In Robert Blust (ed.), *Currents in Pacific Linguistics: Papers on Austronesian Linguistics and Ethnolinguistics in honour of George W. Grace* (pp. 415–32). Canberra: Pacific Linguistics C-117.
- (1993). Tonogenesis in New Caledonia. In Jerold A. Edmondson and Kenneth J. Gregerson (eds), *Tonality in Austronesian Languages* (pp. 155–73). Honolulu: University of Hawaii Press. (Oceanic Linguistics Special Publication, 24.)
- Roberts, Ian G. (1985). Agreement patterns and the development of the English modal auxiliaries. *Natural Language and Linguistic Theory* 3, 21–58.
- (1993a). *Verbs and Diachronic Syntax*. Dordrecht: Kluwer.
- (1993b). A formal account of grammaticalization in the history of Romance futures. *Folia Linguistica Historica* 13 (1/2), 219–58.
- (1994). Two types of head movement in Romance. In Lightfoot and Hornstein 1994 (pp. 207–42).
- (1997). Directionality and word order change in the history of English. In van Kemenade and Vincent 1997 (pp. 397–426).
- (1999). Verb movement and markedness. In De Graff 1999b (pp. 257–84).
- Roberts, Julie (1997). Hitting a moving target: acquisition of sound change in progress by Philadelphia children. *Language Variation and Change* 9(2), 249–66.
- Roberts, Julie and Labov, William (1995). Learning to talk Philadelphian: acquisition of short *a* by preschool children. *Language Variation and Change* 7(1), 101–12.
- Roberts, Sydney Castle (1966). *Adventures with Authors*. Cambridge: Cambridge University Press.
- Robins, Robert Henry (1997). *A Short History of Linguistics*. London and New York: Longman.
- Robinson, Orrin W., III (1975). Abstract phonology and the history of umlaut. *Lingua* 37, 1–29.
- (1976). A “scattered” rule in Swiss German. *Language* 52, 148–62.
- Robson, Barbara (1975). Jenepher revisited: adult language change. In Ralph W. Fasold and Roger W. Shuy (eds), *Analyzing Variation in Language: Papers from the Second Colloquium on New Ways of Analyzing Variation* (pp. 283–90). Washington, DC: Georgetown University Press.
- Rock, I. (1983). *The Logic of Perception*. Cambridge, MA: MIT Press.
- Rogers, M. E. (1983). *Diffusion of Innovations*. 3rd edn. New York: Free Press.
- Rögnvaldsson, E. (1996). Word order variation in the VP in Old Icelandic. *Working Papers in Scandinavian Syntax* [Department of Scandinavian Languages, University of Lund], 57.
- Rohrbacher, Bernhard (1994). The Germanic VO languages and the full paradigm: a theory of V to I raising. Ph.D. dissertation, University of Massachusetts, Amherst.
- Romaine, Suzanne (1982). *Socio-Historical Linguistics: Its Status and Methodology*. Cambridge: Cambridge University Press.
- (1984). *The Language of Children and Adolescents*. Oxford: Blackwell.

- (1988). Contributions from sociolinguistics to historical linguistics. In A. Joly (ed.), *La linguistique génétique: histoire et théories* (pp. 343–68). Lille: Presses Universitaires de Lille III.
- (1989). The role of children in linguistic change. In Breivik and Jahr 1989 (pp. 199–225).
- (1995). The grammaticalization of irrealis in Tok Pisin. In Bybee and Fleischman 1995 (pp. 1–39).
- (1999). The grammaticalization of the proximative in Tok Pisin. *Language* 75(2), 322–46.
- Romaine, Suzanne and Lange, Deborah (1991). The use of *like* as a marker of reported speech and thought: a case of grammaticalization in progress. *American Speech* 66, 227–79.
- Ronneberger-Sibold, Elke (1990). The genesis of suppletion through morphological change. In Werner Bahner (ed.), *Proceedings from the 14th International Congress of Linguists* (pp. 628–31). Berlin: Akademie-Verlag.
- Rosapelly, Ch.-L. (1876). Inscriptions des mouvements phonétiques. In *Physiologie expérimentale: travaux du laboratoire de M. Marey* (vol. II, pp. 109–31). Paris: G. Masson.
- Rosch, Elinor (1973). Natural categories. *Cognitive Psychology* 4, 328–50.
- Ross, Malcolm D. (1993). Tonogenesis in the North Huon Gulf chain. In Jerold A. Edmondson and Kenneth J. Gregerson (eds), *Tonality in Austronesian Languages* (pp. 133–54). Honolulu: University of Hawaii Press. (Oceanic Linguistics Special Publication, 24.)
- (1996). Contact-induced change and the comparative method: cases from Papua New Guinea. In Durie and Ross 1996 (pp. 180–217).
- Rotenberg, Joel (1978). The syntax of phonology. Ph.D. dissertation, MIT.
- Rousseau, Pascale and Sankoff, David (1978). Advances in variable rule methodology. In David Sankoff (ed.), *Linguistic Variation: Models and Methods* (pp. 57–69). New York: Academic Press.
- Rousset, Jean (abbé) (1891). *Les modifications phonétiques du langage, étudiées dans le patois d'une famille de Cellefrouin (Charante)*. Paris: H. Welter.
- Rubba, Jo (1994). Grammaticization as semantic change. In Pagliuca 1994 (pp. 81–101).
- Rudwick, Martin J. S. (1970). The strategies of Lyell's *Principles of Geology*. *Isis* 61, 5–33.
- (1971). Uniformity and progression: reflections on the structure of geological theory in the age of Lyell. In R. H. D. Roller (ed.), *Perspectives in the History of Science and Technology* (pp. 209–27). Norman, OK: University of Oklahoma Press.
- (1972). *The Meaning of Fossils: Episodes in the History of Palaeontology*. New York: American Elsevier. [Rev. New York: Science History Publications, 1976. Repr. Chicago: University of Chicago Press, 1985.]
- (1997). *Georges Cuvier, Fossil Bones, and Geological Catastrophes: New Translations and Interpretations of the Primary Texts*. Chicago: University of Chicago Press.
- (1998). Lyell and the *Principles of Geology*. In Blundell and Scott 1998 (pp. 3–15).
- Ruhlen, Merritt (1978). Nasal vowels. In Joseph Greenberg (ed.), *Universals of Human Language: Volume 2: Phonology* (pp. 203–42). Stanford: Stanford University Press.
- (1994). *On the Origin of Languages: Studies in Linguistic Taxonomy*. Stanford: Stanford University Press.
- Ruse, Michael (1989). *The Darwinian Paradigm: Essays on its History, Philosophy, and Religious Implications*. London: Routledge.
- (1999). *Mystery of Mysteries: Is Evolution a Social Construction?* Cambridge, MA: Harvard University Press. [Paperback edn, 2001.]

- (2000). The theory of punctuated equilibria: taking apart a scientific controversy. In Machamer et al. 2000 (pp. 230–53).
- Russell, Bertrand Arthur (1903). *Principles of Mathematics. Vol. 1*. Cambridge: Cambridge University Press. [2nd edn London: George Allen and Unwin, 1937–8, repr. 1985. No further vols appeared in the form originally intended.]
- (1921). *The Analysis of Mind*. London: George Allen and Unwin. (Library of Philosophy.) [Repr. 1961.]
- Russom, Jacqueline Haring (1982). An examination of the evidence for OE indirect passives. *Linguistic Inquiry* 13(4), 677–80.
- Ryan, P. M. (1995). *The Reed Dictionary of Modern Māori*. Auckland: Reed Books in association with TVNZ.
- Rybczynski, Witold (1999). The ideal city. *Preservation* 50(1), 32–4.
- Ryle, Gilbert (1968a). Thinking and reflecting. In Godfrey Norman Agmondisham Vesey (ed.), *The Human Agent*. London: Macmillan (Royal Institute of Philosophy, Lectures, 1: 1966–7.) [Repr. in Ryle 1971b (pp. 465–79).]
- (1968b). *The Thinking of Thoughts: What is “Le Penseur” Doing? University [of Saskatchewan] Lectures* 18. [Repr. in Ryle 1971b (pp. 480–96).]
- (1971a). *Collected Papers. Volume 1: Critical Essays*. New York: Barnes and Noble.
- (1971b). *Collected Papers. Volume 2: Collected Essays, 1929–1968*. New York: Barnes and Noble.
- Rymer, Hazel, Ferrucci, Fabrizio, and Locke, Corinne A. (1998). Mount Etna: monitoring in the past, present, and future. In Blundell and Scott 1998 (pp. 335–47).
- Sag, Ivan A. (1997). English relative clause constructions. *Journal of Linguistics* 33, 431–83.
- Salm, Max (1990). *Analogie im Germanischen: historisch-morphologische Studien zum Ablautsystem der e-Verben anhand des Deutschen und Schwedischen kontrastiv dargestellt*. Frankfurt: Lang.
- Salmons, Joseph C. (1992). *Accentual Change and Language Contact: Comparative Survey and a Case Study of Early Northern Europe*. Stanford: Stanford University Press.
- (1993). *The Glottalic Theory: Survey and Synthesis*. McLean, VA: Institute for the Study of Man. (*Journal of Indo-European Studies Monographs*, 10.)
- Salthe, Stanley N. (1993). *Development and Evolution: Complexity and Change in Biology*. Cambridge, MA: MIT Press. (Bradford Books.)
- Salwen, Bert (1973). Archaeology in Megalopolis. In Charles L. Redman (ed.), *Research and Theory in Current Archeology* (pp. 151–63, 355–87). New York: John Wiley.
- Sampson, Geoffrey (1980). *Schools of Linguistics: Competition and Evolution*. London: Hutchinson.
- Samuels, M. L. (1972). *Linguistic Evolution, with Special Reference to English*. Cambridge: Cambridge University Press.
- Sandalo, Filomena (1995). A grammar of Kadiwéu. Ph.D. dissertation, University of Pittsburgh.
- Sanders, Gerald (1990). On the analysis and implications of Maori verb alternations. *Lingua: International Review of General Linguistics* 80(2–3), 149–96.
- (1991). Levelling and reanalysis in the history of Polynesian passive formations. *Journal of the Polynesian Society* 100(1), 71–90.
- Sandfeld, Kristian (1930). *Linguistique balkanique: problèmes et résultats*. Paris: É. Champion. [Repr. Paris: Klincksieck, 1968.]
- Sankoff, David (1988). Variable rules. In U. Ammon, N. Dittmar, and K. J. Mattheier (eds), *Sociolinguistics: An International Handbook of the Science of Language and Society* (vol. 2, pp. 984–97). Berlin: de Gruyter.

- Sankoff, David and Labov, William (1979). On the uses of variable rules. *Language in Society* 8, 189–222.
- Sankoff, Gillian (1980). *The Social Life of Language*. Philadelphia: University of Pennsylvania Press.
- Sankoff, Gillian and Brown, Penelope (1976). The origins of syntax in discourse. *Language* 52, 631–66.
- Santayana, George (1905). Flux and constancy in human nature. In *The Life of Reason, or the Phases of Human Progress. Vol. 1: Introduction and Reason in Common Sense* (pp. 269–91). New York: Charles Scribner's Sons. [2nd edn, with a new preface, 1924.]
- Santorini, Beatrice (1989). The generalization of the verb-second constraint in the history of Yiddish. Ph.D. dissertation, University of Pennsylvania.
- (1992). Variation and the change in Yiddish subordinate clause word order. *Natural Language and Linguistic Theory* 10, 595–640.
- (1993). The rate of phrase structure change in the history of Yiddish. *Language Variation and Change* 5(3), 257–83.
- Sapir, Edward (1913). Wiyot and Yurok, Algonkin languages of California. *American Anthropologist* 15, 617–46.
- (1921). *Language: An Introduction to the Study of Speech*. New York: Harcourt, Brace, and World. [Repr. 1949, 1965 (Harvest Books).]
- (1925). The Hokan affinity of Subtiaba in Nicaragua. *American Anthropologist* 27, 402–35, 491–527.
- Sarjvelaže, Z. (1984). *Kartuli salit'erat'uro ist'oriis əsavali*. Tbilisi: Ganatleba.
- Sasse, Hans-Jürgen (1992). Theory of language death. In Matthias Brenzinger (ed.), *Language Death: Factual and Theoretical Explanations with Special Reference to East Africa* (pp. 7–30). Berlin and New York: Mouton de Gruyter.
- Savan, David (1980). Abduction and semiotics. In Irmengard Rauch and Gerald F. Carr (eds), *The Signifying Animal* (pp. 252–62). Bloomington: Indiana University Press.
- Savitt, Steven F. (ed.) (1995). *Time's Arrows Today: Recent Physical and Philosophical Work on the Direction of Time*. Cambridge: Cambridge University Press.
- Saxena, Anju (1988). The case of the verb "say" in Tibeto-Burman. *BLS* 14, 375–88.
- (1995). Unidirectional grammaticalization: diachronic and cross-linguistic evidence. *STUF (Sprachtypologie und Universalienforschung)* 48(4), 350–72.
- Scaglione, Aldo (1981). *The Theory of German Word Order from the Renaissance to the Present*. Minneapolis: University of Minnesota Press.
- Schaller, Helmut W. (1975). *Die Balkansprachen: Eine Einführung in die Balkanphilologie*. Heidelberg: Winter.
- Schane, Sanford A. (1971). The phoneme revisited. *Language* 47(3), 503–21.
- (1972). Natural rules in phonology. In Robert P. Stockwell and Ronald K. S. Macaulay (eds), *Linguistic Change and Generative Theory* (pp. 199–229). Bloomington: Indiana University Press.
- Scheibman, J. (n.d.). I dunno but . . . : a usage-based account of the phonological reduction of *don't* in conversation. Manuscript.
- Scherer, Wilhelm (1868). *Zur Geschichte der deutschen Sprache*. Berlin: Duncker. [Repr. Amsterdam and Philadelphia: John Benjamins, 1995. (Amsterdam Classics in Linguistics, 16.)]
- Scheuermeier, Paul (1943). *Bauernwerk in Italien, der italienischen und rätoromanischen Schweiz: eine sprach- und sachkundliche Darstellung landwirtschaftlicher Arbeiten und Geräte. . .* Erlenbach: E. Rentsch. (Sprach- und Sachatlas Italiens und der Südschweiz, eds Karl Jaberg and Jakob Jud, Illustrationsband.)

- Schickele, Peter (1976). *The Definitive Biography of P.D.Q. Bach (1807–1742?)*. New York: Random House.
- Schiffrin, Deborah (1987). *Discourse Markers*. Cambridge: Cambridge University Press. (Studies in Interactional Sociolinguistics, 5.)
- (1990). Between text and context: deixis, anaphora, and the meaning of *then*. *Text* 10, 245–70.
- (1992). Discourse markers. In William Bright (ed.), *International Encyclopedia of Linguistics* (vol. 1, pp. 361–3). New York: Oxford University Press.
- Schindewolf, Otto (1936). *Paläontologie, Entwicklungslehre und Genetik*. Berlin: Bornträger.
- (1950). *Grundfragen der Paläontologie*. Stuttgart: Schweizerbart.
- Schladt, Mathias (2000). The typology and grammaticalization of reflexives. In Frajzyngier and Curl 2000a (pp. 103–24).
- Schleicher, August. (1848–50). *Sprachvergleichende Untersuchungen, Band I: Zur vergleichenden Sprachengeschichte*. Bonn: H. B. König, 1848. (*Linguistische Untersuchungen, Band II: Die Sprachen Europas in systematischer Übersicht*, 1850.) [Repr. Frankfurt: Minerva, 1983.]
- (1860). *Die deutsche Sprache*. Stuttgart: Cotta.
- (1861–2). *Compendium der vergleichenden Grammatik der indogermanischen Sprachen: Kurzer Abriss einer Laut- und Formenlehre der indogermanischen Ursprache, des Altindischen, Altiranischen, Altgriechischen, Altitalischen, Altkeltischen, Altslawischen, Litauischen und Altheutschen*. Weimar: Böhlau. [4th edn, eds Johannes Schmidt and August Leskien, 1876.]
- (1865). *Über die Bedeutung der Sprache für die Naturgeschichte des Menschen*. Weimar: Böhlau. [Trans. J. Peter Maher as *On the Significance of Language for the Natural History of Man* in Koerner 1983d (pp. 73–82).]
- (1868). Eine fabel in indogermanischer ursprache. *Beiträge zur vergleichenden Sprachforschung* 5, 206–8.
- (1873). *Die Darwinsche Theorie und die Sprachwissenschaft: offenes Sendschreiben an Herrn Dr. Ernest Hackel . . . von Aug. Schleicher*. Weimar: Böhlau. 2nd edn; 1st edn 1863. Trans. Alexander V. W. Bickers, 1863, repr. as “The Darwinian theory and the science of language” in Koerner 1983d (pp. 1–71).]
- Schlink, Bernhard (1995). *Der Vorleser: Roman*. Zurich: Diogenes. [Trans. Carol Jane Brownaway as *The Reader*. New York: Pantheon, 1997, and Vintage Books, 1998.]
- Schmidt, Johannes (1872). *Die Verwandtschaftsverhältnisse der indogermanischen Sprachen*. Weimar: Böhlau.
- (1890). Schleicher, August. *Allgemeine deutsche Biographie* 31, 402–15. [Repr. in Sebeok 1966 (vol. 1, pp. 374–95).]
- Schourup, Lawrence (1973). A cross-linguistic study of vowel nasalization. *Ohio State University Working Papers in Linguistics* 15, 190–221.
- Schuchardt, Hugo (1885). *Über die Lautgesetze: gegen die Junggrammatiker*. Berlin: Robert Oppenheim. [Repr. with English transl. as “On sound laws: against the neogrammarians” in Venneman and Wilbur 1972 (pp. 1–72).]
- (1925). An Don Ramón Menéndez Pidal. In Comisión organizadora 1925 (p. ix).
- (1928). *Hugo Schuchardt-Brevier*, ed. Leo Spitzer. Halle: Niemeyer.
- Schwartz, Jeffrey H. (1999). *Sudden Origins: Fossils, Genes, and the Emergence of Species*. New York: John Wiley and Sons.
- Schwenter, Scott A. (1994). The grammaticalization of an anterior in progress: evidence from a Peninsular Spanish dialect. *Studies in Linguistics* 18(1), 71–111.
- Schwenter, Scott A. and Traugott, Elizabeth C. (1995). The semantic and pragmatic development of substitutive complex prepositions in English. In Jucker 1995 (pp. 243–73).

- Scobbie, James M., Gibbon, Fiona, and Hardcastle, William J. (2000). Covert contrast as a stage in the acquisition of phonetics and phonology. In Broe and Pierrehumbert 2000 (pp. 194–207).
- Scotland, Robert W., Siebert, Darrell J., and Williams, David M. (eds) (1994). *Models in Phylogeny Reconstruction*. Oxford: Clarendon Press for the Systematics Association. (Systematics Association Special Volumes, 52; Oxford Science Publications.)
- Scott, Thomas (1996). *Concise Encyclopedia of Biology*. Berlin: Walter de Gruyter. [Transl. and rev. from German-language version by Scott.]
- Scott, Carol Myers and Zhu, Wanjin (1983). *Tóngzhì* in China: language change and its conversational consequences. *Language in Society* 12(4), 477–94.
- Sebeok, Thomas (ed.) (1960). *Style in Language*. Cambridge, MA: Technology Press of MIT; New York: Wiley.
- (ed.) (1966). *Portraits of Linguists: A Biographical Source Book for the History of Western Linguistics, 1746–1963. Volume 1: From Sir William Jones to Karl Brugmann. Volume 2: From Eduard Sievers to Benjamin Lee Whorf*. Bloomington: Indiana University Press. (Indiana University Studies in the History and Theory of Linguistics.)
- Seiler, Hansjakob (1958). Zur Systematik und Entwicklungsgeschichte der griechischen Nominaldeklinatation. *Glotta* 37, 41–67.
- Sekerina, Irina A. (1994). Copper Island (Mednyj) Aleut (CIA): a mixed language. *Languages of the World* 8, 14–31.
- Seliger, Herbert and Vago, Robert (1991). *First Language Attrition*. Cambridge: Cambridge University Press.
- Selkirk, Elisabeth (1972). The phrase phonology of English and French. Ph.D. dissertation, MIT.
- Selvin, Steve (1995). *Practical Biostatistical Methods*. Belmont, CA: Duxbury.
- Seuren, Pieter A. M. (1998). *Western Linguistics: An Historical Introduction*. Oxford and Malden: Blackwell.
- Sgall, Petr (1988). Natürlichkeit, Syntax und Typologie. *Zeitschrift für Phonetik, Sprachwissenschaft und Kommunikationsforschung* 41(4), 463–70.
- Shapiro, Michael (1991). *The Sense of Change: Language as History*. Bloomington: Indiana University Press.
- (1995). A case of distant assimilation: /str/ → /ʃtr/. *American Speech* 70, 101–7.
- Shapiro, Michael and Haley, Michael (eds) (1999). *The Peirce Seminar Papers: Essays in Semiotic Analysis. Vol. 4*. (Proceedings of the International Colloquium on Language and Peircean Sign Theory.) Providence, RI: Berghahn.
- Shapiro, Michael and Shapiro, Marianne (1988). *Figuration in Verbal Art*. Princeton, NJ: Princeton University Press.
- Sheldon, P. R. (1987). Parallel gradualistic evolution of Ordovician trilobites. *Nature* 330, 561–3.
- Shepherd, Susan C. (1982). From deontic to epistemic: an analysis of the modals in the history of English, creoles, and language acquisition. In Anders Ahlquist (ed.), *ICHL* 5 (pp. 316–23). Amsterdam: John Benjamins. (CILT 21.)
- Sherburne, Donald W. (ed.) (1966). *A Key to Whitehead's Process and Reality*. New York: Macmillan.
- Shevoroshkin, Vitaly (1989a). A symposium on the deep reconstruction of languages and cultures. In Vitaly Shevoroshkin (ed.), *Reconstructing Languages and Cultures: Materials from the First International Interdisciplinary Symposium on Language and Prehistory* (pp. 6–8). Bochum: Brockmeyer.

- (1989b). Introductory remarks. In Vitaly Shevoroshkin (ed.), *Explorations in Language Macrofamilies: Materials from the First International Interdisciplinary Symposium on Language and Prehistory* (pp. 4–15). Bochum: Brockmeyer.
- Shibatani, Masayoshi (ed.) (1976). *Japanese Generative Grammar*. New York: Academic Press.
- Shigley-Giusti, Michela (1993). *Essay for a Linguistic Institute Class in Language Contact*. Columbus: Ohio State University.
- Shnukal, Anna (1982). You're gettin' somethink for nothing: two phonological variables of Australian English. *Australian Journal of Linguistics* 2(1), 197–212.
- Short, Thomas L. (1999). A theory of final causation. In Shapiro and Haley 1999.
- Shorter, Edward (1975). *The Making of the Modern Family*. New York: Basic Books.
- Siebert, Frank T., Jr. (1967). The original home of the Proto-Algonquian people. In *Contributions to Anthropology: Linguistics I (Algonquian)* (pp. 13–47). Ottawa: National Museum of Canada. (National Museum of Canada Bulletin, 214.)
- Sihler, Andrew L. (1977). Morphologically conditioned sound changes and OE past participles in *-en*. *General Linguistics* 17, 76–97.
- (1995). *New Comparative Grammar of Greek and Latin*. Oxford: Oxford University Press.
- (2000). *Language History: An Introduction*. Amsterdam: John Benjamins. (CILT 191.)
- Silverstein, Michael (1976). Hierarchy of features and ergativity. In Robert M. W. Dixon (ed.), *Grammatical Categories in Australian Languages* (pp. 112–71). Canberra: Australian Institute of Aboriginal Studies; Atlantic Highlands, NJ: Humanities Press. (Linguistic Series, 22.)
- Simmel, Georg (1908). Vom Wesen der Kultur. *Österreichische Rundschau* 15. [Reduced version in his *Brücke und Tür: Essays des Philosophen zur Geschichte, Religion, Kunst und Gesellschaft*, eds Michael Landmann and Margarete Susman (pp. 86–94), Stuttgart: K. F. Köhler, 1957. Transl. Roberta Ash as “Subjective Culture” in his *On Individuality and Social Forms: Selected Writings*, ed. Donald N. Levine (pp. 227–34), Chicago: University of Chicago Press, 1971. (Heritage of Sociology.)]
- Simpson, George Gaylord (1944). *Tempo and Mode in Evolution*. New York: Columbia University Press. (Columbia Biological Series, 15.) [Repr. in the Columbia Classics in Evolution Series, 1984.]
- (1970). Uniformitarianism: an inquiry into principle, theory, and method in geohistory and biohistory. In Max K. Hecht and William C. Steere (eds), *Essays in Evolution and Genetics in Honor of Theodosius [Grigorievich] Dobzhansky* (pp. 43–96). New York: Appleton-Century-Crofts (Supplement to *Evolutionary Biology*.)
- (1996). *The Dechronization of Sam Magruder: A Novel*, ed. Joan Simpson Burns. New York: St Martin's Griffin. [Posthumous; excerpted in *Scientific American* 281(3), 52–5, 1999.]
- Singh, Rajendra (ed.) (1996). *Trubetzkoy's Orphan: Proceedings of the Montréal Roundtable “Morphonology: Contemporary Responses”*. Amsterdam: John Benjamins. (CILT 144.)
- Skalička, V. (1979). *Typologische Studien*. Braunschweig: Vieweg.
- Sklar, Lawrence (1974). Up and down, left and right, past and future. *Noûs* 15, 111–29. [Repr. in Sklar 1985 (pp. 305–26) and in Le Poidevin and MacBeath 1993 (pp. 99–116).]
- (1981). Time, reality, and relativity. In Healey 1981 (pp. 129–42).
- (1985). *Philosophy and Spacetime Physics*. Berkeley: University of California Press.
- Skousen, Royal (1989). *Analogical Modeling of Language*. Dordrecht, etc.: Kluwer Academic.
- Slobin, Dan I. (1994). Talking perfectly: discourse origins of the present perfect. In Pagliuca 1994 (pp. 119–33).

- Smart, J. J. C. (1949). The river of time. *Mind* 58, 483–94. [Repr. in Antony G. N. Flew (ed.), *Essays in Conceptual Analysis* (pp. 213–27). London: Macmillan, 1956.]
- (1955). Spatializing time. *Mind* 64, c.240. [Repr. in Gale 1967 (pp. 163–7).]
- (1967). Time. In Edwards 1967 (pp. 126–34).
- Smeets, Rieks, (ed.) (1994). *The Indigenous Languages of the Caucasus. Volume 4: Northeast Caucasian Languages, Part 2*. Delmar, NY: Caravan Books.
- Smith, Adam (1761). *Dissertation on the Origin of Languages: or, Considerations . . . Added to the Theory of Moral Sentiments. . .* 3rd edn. London: A. Millar, A. Kinkaid, and J. Bell. [Repr. Tübingen: Narr, 1970.]
- Smith, J. W. (1990). Time, change, and contradiction. *Australasian Journal of Philosophy* 68, 178–88.
- Smith, N. J. J. (1997). Bananas enough for time travel? *British Journal for the Philosophy of Science* 48, 363–89.
- Smith, Robert Freeman (1989). Communication . . . : Robert Freeman Smith replies. *American Historical Review* 94(4), 1247.
- Smyth, Herbert Weir (1956). *Greek Grammar*. 2nd edn rev. Gordon M. Messing. Cambridge, MA: Harvard University Press. [1st edn 1916.]
- Sober, Elliott (1984). *The Nature of Selection: Evolutionary Theory in Philosophical Focus*. Cambridge, MA: MIT Press. (Bradford Books.)
- (1988). *Reconstructing the Past: Parsimony, Evolution, and Inference*. Cambridge, MA: MIT Press. (Bradford Books.)
- (1993). *Philosophy of Biology*. Boulder, CO: Westview Press. (Dimensions of Philosophy Series.)
- (ed.) (1994). *Conceptual Issues in Evolutionary Biology*. Cambridge, MA: MIT Press.
- Somit, Albert and Peterson, Steven A. (eds) (1992). *The Dynamics of Evolution: The Punctuated Equilibrium Debate in the Natural and Social Sciences*. Ithaca, NY: Cornell University Press, 1992. [Later version of a special issue of the *Journal of Social and Biological Structures* [Academic Press], July 1989.]
- Sommerstein, Alan (1973). *The Sound Pattern of Ancient Greek*. Oxford: Blackwell. (Philological Society Publications, 23.)
- Sonderegger, Stefan (1961). Das Althochdeutsche der Vorakte der älteren St Galler Urkunden: ein Beitrag zum Problem der Urkundensprache in althochdeutscher Zeit. *Zeitschrift für Mundartforschung* 28, 251–86.
- (1970). *Althochdeutsch in St Gallen: Ergebnisse und Probleme der althochdeutschen Sprachüberlieferung in St. Gallen vom 8. bis ins 12. Jahrhundert*. St Gallen: Verlag Ostschweiz; Sigmaringen: Jan Thorbecke Verlag. (Bibliotheca Sangallensis, 6.)
- Sørensen, Marie Louise Stig (1996). Scandinavia in the Bronze Age. In Fagan 1996 (pp. 623–5).
- Spade, Paul Vincent (ed.) (1999). *The Cambridge Companion to Ockham*. Cambridge: Cambridge University Press.
- Spencer, Andrew (1991). *Morphological Theory*. Oxford: Blackwell.
- Spencer, Andrew and Zwicky, Arnold M. (eds) (1998). *The Handbook of Morphology*. Oxford: Blackwell.
- Spencer, Hamish G. (1995). Models of speciation by founder effect: a review. In Lambert and Spencer 1995 (pp. 141–56).
- Sperry, R. (1968). Plasticity of neural maturation. *Developmental Biology Supplement* 2, 306–27.
- Sproat, R. and Fujimura, O. (1993). Allophonic variation in English /l/ and its implications for phonetic implementation. *Journal of Phonetics* 21, 291–311.

- Sprouse, Rex A. and Vance, Barbara (1999). An explanation for the decline of null pronouns in certain Germanic and Romance languages. In De Graff 1999b (pp. 257–84).
- Stammerjohann, Harro (general ed.) (1996). *Lexicon Grammaticorum: Who's Who in the History of World Linguistics*. Tübingen: Niemeyer.
- Stampe, David (1969). The acquisition of phonetic representation. *CLS* 5, no. 1, 443–53.
- Stanley, Steven M. (1975). A theory of evolution above the species level. *Proceedings of the National Academy of Sciences of the USA* 72, 646–50.
- (1979). *Macroevolution: Pattern and Process*. San Francisco: Freeman. [Repr. Baltimore, MD: Johns Hopkins University Press, 1998.]
- (1981). *The New Evolutionary Timetable*. New York: Basic Books.
- Stanley, Steven M. and Yang, Xiangning (1982). Approximate evolutionary stasis for bivalve morphology over millions of years: a multivariate, multilanguage study. *Paleobiology* 13, 113–39.
- Stearns, Stephen C. and Hoekstra, Rolf F. (2000). *Evolution: An Introduction*. Oxford: Oxford University Press.
- Stebbins, George Ledyard (1982). *Darwin to DNA, Molecules to Humanity*. San Francisco: Freeman.
- Stebbins, George Ledyard and Ayala, Francisco José (1981). Is a new evolutionary synthesis necessary? *Science* 213, 967–71.
- Stemberger, Joseph Paul and MacWhinney, Brian (1988). Are inflected forms stored in the lexicon? In Michael Hammond and Michael Noonan 1988 (pp. 101–16).
- Stenseth, Nils C. and Maynard Smith, John (1984). Coevolution in ecosystems: Red Queen evolution or stasis? *Evolution* 38, 870–80.
- Stent, Gunther Siegmund (1978). *Paradoxes of Progress*. San Francisco: Freeman.
- Steriade, Donca (1987). Redundant values. *CLS* 23, no. 2. *Parasession on Autosegmental and Metrical Phonology*, 339–62.
- (2000). Paradigm uniformity and the phonetics–phonology boundary. In Broe and Pierrehumbert 2000 (pp. 313–34).
- Stern, Gustaf (1931). *Meaning and Change of Meaning*. Bloomington: Indiana University Press.
- Stevens, K. N. (1971). Airflow and turbulence noise for fricative and stop consonants: static considerations. *Journal of Acoustical Society of America* 50, 1180–92.
- Stockwell, Robert (1978). Perseverance in the English vowel shift. In Jacek Fisiak (ed.), *Recent Developments in Historical Phonology* (pp. 337–48). The Hague: Mouton. (TIL 4.)
- Stockwell, Robert P. and Minkova, Donka (1987). The English vowel shift: problems of coherence and explanation. In Dieter Kastovsky, Gero Bauer, and Jacek Fisiak (eds), *Karl Luick in Memoriam* (pp. 355–94). Tübingen: Narr. (Tübinger Beiträge zur Linguistik.)
- Stolz, Thomas (1987). Natürlichkeit und Interferenz: Fallbeispiele aus dem morphologischen Bereich in Sprachkontaktsituationen. *Papiere zur Linguistik* 36(1), 17–44.
- Stone, Lawrence (1977). *The Family, Sex, and Marriage in England, 1500–1800*. New York: Harper and Row.
- Strauss, Steven L. (1976). The nature of umlaut in Modern Standard German. *CUNY Forum* 1, 121–44.
- Stravinsky, Igor [Fyodorovich] (1942). *Poétique musicale sous forme de six leçons*. Cambridge, MA: Harvard University Press [and London: Humphrey Milford]. (Charles Eliot Norton Lectures for 1939–40.) [Trans. Arthur Knodel and Ingolf Dahl as *Poetics of Music in the Form of Six Lessons*. Cambridge, MA: Harvard University Press, 1947. Repr. 1970, 1983. (Harvard Paperbacks.)]

- Strickberger, Monroe W. (1990). *Evolution*. New York: Macmillan. [2nd edn, 1996. 3rd edn, 2000.]
- Strobach, Niko (1998). *The Moment of Change: A Systematic History in the Philosophy of Space and Time*. Dordrecht: Kluwer Academic. (New Synthèse Historical Library: Texts and Studies in the History of Philosophy, 45.)
- Sturtevant, Edgar H. (1917). *Linguistic Change*. Chicago: University of Chicago Press.
- (1947). *An Introduction to Linguistic Science*. New Haven: Yale University Press.
- Suárez, Jorge (1983). *The Mesoamerican Indian Languages*. Cambridge: Cambridge University Press. (Cambridge Language Surveys.)
- Sun, Chaofen (1996). *Word Order Change and Grammaticalization in the History of Chinese*. Stanford: Stanford University Press.
- Supalla, Samuel J. (1990). Segmentation of manually coded English: problems in the mapping of English in the visual/gestural mode. Ph.D. dissertation, University of Illinois.
- Sussman, Harvey M., McCaffrey, Helen A., and Matthews, Sandra A. (1991). An investigation of locus equations as a source of relational invariance for stop place category. *Journal of the Acoustical Society of America* 90(3), 1309–25.
- Svantesson, Jan-Olof (1983). *Kammu Phonology and Morphology*. Lund: Gleerup. (Travaux de l'institut de linguistique de Lund, 18.)
- (1989). Tonogenetic mechanisms in northern Mon-Khmer. *Phonetica* 46, 60–79.
- Svorou, Soteria (1994). *The Grammar of Space*. Amsterdam and Philadelphia: John Benjamins. (TSL 25.)
- Swadesh, Morris (1950). Salish internal relationships. *International Journal of American Linguistics* 16, 157–67.
- (1951). Diffusional cumulation and archaic residue as historical explanation. *Southwestern Journal of Anthropology* 7, 1–21.
- (1954). Perspectives and problems of Amerindian comparative linguistics. *Word* 10, 306–32.
- Swanton, John R. (1912). *A Dictionary of the Biloxi and Ofo Languages*. Washington, DC: Government Printing Office. (Bureau of American Ethnology, Bulletin 47.)
- Sweet, H. (1899). *The Practical Study of Languages*. London: Dent.
- Sweetser, Eve E. (1988). Grammaticalization and semantic bleaching. In Axmaker et al. 1988 (pp. 389–405).
- (1990). *From Etymology to Pragmatics: Metaphorical and Cultural Aspects of Semantic Structure*. Cambridge: Cambridge University Press. (CSL 54.)
- Swift, Jonathan (1964). *The Prose Writings. . . . Volume 1: "A Tale of a Tub" with Other Early Works 1696–1707*, ed. Herbert Davis. Oxford: Blackwell. [Vol. 1 of 14, 1965[sic]–73.]
- (1973). *Selected Works. The Writings. . . : Authoritative Texts, Backgrounds, Criticism*, eds Robert A. Greenberg and William Bowman Piper. New York: Norton. (Norton Critical Editions.)
- Swinburne, Richard (ed.) (1982). *Space, Time, and Causality*. Dordrecht: D. Reidel; Hingham, MA: Kluwer Boston.
- Sykes, Bryan (ed.) (1999). *The Human Inheritance: Genes, Language, and Evolution*. Oxford: Oxford University Press.
- Syrdal, A. K. and Gopal, H. S. (1986). A perceptual model of vowel recognition based on the auditory representation of American English vowels. *Journal of the Acoustical Society of America* 79(4), 1086–1100.
- Szemerényi, Oswald (1968). The Attic "Rückverwandlung". In Manfred Mayrhofer, Fritz Lochner-Hüttenbach, and Hans Schmeja (eds), *Studien zur Sprachwissenschaft*

- und Kulturkunde: Gedenkschrift für Wilhelm Brandenstein (pp. 139–57). Innsbrucker Beiträge zur Kulturwissenschaft, 14.
- Taavitsainen, Irma (1994). Subjectivity as a text-type marker in historical stylistics. *Language and Literature* 3(3), 197–212.
- Tabor, Whitney (1993/1994a). The gradual development of degree modifier *sort of* and *kind of*: a corpus proximity model. *CLS* 29, no. 1, 451–65.
- (1994b). Syntactic innovation: a connectionist model. Ph.D. dissertation, Stanford University.
- Tabor, Whitney and Traugott, Elizabeth C. (1998). Structural scope expansion and grammaticalization. In Ramat and Hopper 1998 (pp. 229–72).
- Talmy, Leonard (1988). Force dynamics in language and cognition. *Cognitive Science* 2, 49–100.
- Tarallo, Fernando (1996). Turning different at the turn of the century: 19th century Brazilian Portuguese. In Guy, Feagin, Schiffrin, and Baugh 1996 (pp. 199–220).
- Tatlock, J. S. P. and Kennedy, A. G. (1927). *A Concordance to the Complete Works of Geoffrey Chaucer*. Washington, DC: Carnegie Institute.
- Taylor, Ann (1990). Clitics and configurationality in Ancient Greek. Ph.D. dissertation, University of Pennsylvania.
- (1994). The change from SOV to SVO in Ancient Greek. *Language Variation and Change* 6, 1–37.
- Taylor, John R. and MacLaury, Robert E. (eds) (1995). *Language and the Cognitive Construal of the World*. Berlin and New York: Mouton de Gruyter. (TIL 82.)
- Teeter, Karl V. (1964). Algonquian languages and genetic relationship. In *Proceedings of the 9th International Congress of Linguists* (pp. 1026–33). The Hague: Mouton.
- (1994a). Re: 5.1409 Comparative method in syntax, continued. Posting 5.1433, message 2, to LINGUIST (9 December 1994).
- (1994b). Comparative grammar, reply to Alexis Manaster-Ramer. Posting 5.1433, message 3, to LINGUIST (10 December 1994).
- (1994c). Comparative method. Posting 5.1448, message 2, to LINGUIST (12 December 1994).
- (1994d). Re: 5.1448 Comparative method. Posting 5.1477, message 2, to LINGUIST (16 December 1994).
- Ternes, Elmar (1977). Konsonantische Anlautveränderungen in den keltischen und romanischen Sprachen. *Romanistisches Jahrbuch* 28(1), 19–53.
- Thagard, Paul (1988). *Computational Philosophy of Science*. Cambridge, MA, and London: MIT Press.
- Thayer, Alexander Wheelock, Deiters, Hermann, and Riemann, Hugo (eds) (1908). *The Life of Ludwig von Beethoven*. [Rev. and expanded H. Deiters and H. Riemann as *Ludwig von Beethovens Leben*, Leipzig: Breitkopf and Härtel, vol. 5, 1923.]
- Thibault, Pierrette and Vincent, Diane (1990). *Un corpus de français parlé*. Montreal: Recherches Sociolinguistiques.
- Thiele, Petra (1992). Suppletion im Verbalbereich: Evidenzen aus dem Kapverdischen und seinen Kontaktsprachen. *Zeitschrift für Phonetik, Sprachwissenschaft und Kommunikationsforschung* 45, 468–77.
- Thom, René (1975). *Structural Stability and Morphogenesis: An Outline of a General Theory of Models*. Reading, MA: W. A. Benjamin. [Transl. D. H. Fowler from the French edn, 1972.]
- Thomas-Flinders, Tracy (1981). Initial lenition in Celtic: evidence for inflection as a phonological process. In Tracy Thomas-Flinders (ed.), *Inflectional Morphology*:

- Introduction to the Extended Word-and-Paradigm Theory* (pp. 73–83). *UCLA Occasional Papers 4: Working Papers in Morphology*.
- Thomason, Sarah G. (1976). Analogic change as grammar complication. In Christie (pp. 401–9).
- (1980). Review of Anttila 1977. *Language* 56(2), 418–24.
- (1995). Language mixture: ordinary processes, extraordinary results. In Carmen Silva-Corvalán (ed.), *Spanish in Four Continents: Studies in Language Contact and Bilingualism* (pp. 13–33). Washington, DC: Georgetown University Press.
- (1997a). Mednyj Aleut. In Sarah G. Thomason (ed.), *Contact Languages: A Wider Perspective* (pp. 449–68). Amsterdam and Philadelphia: John Benjamins.
- (1997b). Ma'a (Mbugu). In Sarah G. Thomason (ed.), *Contact Languages: A Wider Perspective* (pp. 469–87). Amsterdam and Philadelphia: John Benjamins.
- (1997c). On mechanisms of interference. In Stig Eliasson and Ernst Håkon Jahr (eds), *Language and its Ecology: Essays in Memory of Einar Haugen* (pp. 181–207). Berlin: Mouton de Gruyter.
- (1997d). A typology of contact languages. In Arthur K. Spears and Donald Winford (eds), *Pidgins and Creoles: Structure and Status* (pp. 71–90). Amsterdam and Philadelphia: John Benjamins.
- (2001). *Language Contact: An Introduction*. Washington, DC: Georgetown University Press.
- Thomason, Sarah G. and Kaufman, Terrence (1988). *Language Contact, Creolization, and Genetic Linguistics*. Berkeley and Los Angeles: University of California Press.
- Thompson, Laurence C. and Kinkade, M. Dale (1990). Languages. In Wayne Suttles (ed.), *Northwest Coast (Handbook of North American Indians. Volume 7)* (pp. 30–1). Washington, DC: Smithsonian Institution.
- Thomson, Iain (1999). *Frank Lloyd Wright: A Visual Encyclopedia*. San Diego, CA: Thunder Bay Press.
- Thorne, Kip S. (1994). *Black Holes and Time Warps: Einstein's Outrageous Legacy*. New York: Norton. (Commonwealth Fund Book Program.)
- Thurneysen, Rudolf (1980). *A Grammar of Old Irish*, transl. D. A. Binchy and Osborn Bergin. Dublin: Institute for Advanced Studies.
- Tieken-Boon van Ostade, Ingrid (1987). *The Auxiliary DO in Eighteenth-Century English: A Sociohistorical-Linguistic Approach*. Dordrecht: Foris.
- Tiersma, Peter Meijes (1982). Local and general markedness. *Language* 58(4), 832–49.
- Timberlake, Alan (1977). Reanalysis and actualization in syntactic change. In Li 1977 (pp. 141–77).
- Timmers, Corine (1977). Les vicissitudes de l'r en français, ou comment traiter les exceptions à un changement phonétique. *Utrecht Working Papers in Linguistics* 3, 31–71.
- Timpanaro, Sebastiano (1972). Friedrich [von] Schlegel i gli inizi della linguistica indoeuropea in Germania. *Critica storica* 9, 72–105. [Transl. John Peter Maher as "Friedrich [von] Schlegel and the Development of Comparative Linguistics in the 19th Century," in Friedrich [von] Schlegel, *Über die Sprache und Weisheit der Ind(i)er: Ein Beitrag zur Begründung der Altert(h)umskunde*, ed. Ernst Frideryk Konrad Koerner (pp. xi–xlviil["xxxvii"]), Amsterdam: John Benjamins, 1977.]
- Tipler, Frank (1974). Rotating cylinders and the possibility of global causality violations. *Physical Review D* 9 April 15, 2203–6.
- (1976a). Causality violation in general relativity. Ph.D. dissertation, University of Maryland.

- (1976b). Causality violations in asymptotically flat space-times. *Physical Review Letters* 37, 879–82.
- Tomlin, Russell S. (1986). *Basic Word Order: Functional Principles*. London: Croom Helm.
- Tonelli, Livia and Dressler, Wolfgang U. (eds) (1993). *Natural Morphology: Perspectives for the Nineties*. Padova: Unipress.
- Tort, Patrick (1980). *Evolutionnisme et linguistique, suivi de August Schleicher, "La théorie de Darwin et la science du langage" [and] "De l'importance du langage pour l'histoire naturelle de l'homme"*. Paris: Vrin.
- Toynbee, Arnold Joseph (1935). *A Study of History. Volumes 1–10*. 2nd edn. London: Oxford University Press. [1st edn issued under the auspices of the Royal Institute of International Affairs, 1934.]
- Trager, George L. (1940). One phonemic entity becomes two: the case of "short a." *American Speech* 15, 255–8.
- Tranel, Bernard (1990). On suppletion and French liaison. *Probus* 2(2), 169–208.
- (1996). French liaison and elision revisited: a unified account within Optimality theory. In Claudia Parodi et al. (eds), *Aspects of Romance Linguistics: Selected Papers from the Linguistic Symposium on Romance Languages XXIV* [Los Angeles, CA; April, 1994] (pp. 433–55). Washington, DC: Georgetown University Press.
- Trask, Robert L. (1996). *Historical Linguistics*. London, New York, Sydney and Auckland: Arnold.
- (1999). *Dictionary of Historical and Comparative Linguistics*. Edinburgh: Edinburgh University Press.
- Traugott, Elizabeth C. (1972). *A History of English Syntax*. New York: Holt, Rinehart and Winston.
- (1973a). Le changement linguistique et sa relation à l'acquisition de la langue maternelle. In S. Leconte and J. Le Galliot (eds), *Le changement linguistique. Langues* 8(4) [no. 32], 39–52.
- (1973b). Some thoughts on natural syntactic processes. In C.-J. Bailey and R. Shuy (eds), *New Ways of Analyzing Variation in English* (pp. 313–22). Washington, DC: Georgetown University Press.
- (1980). Meaning-change in the development of grammatical markers. *Language Sciences* 2, 44–61.
- (1982). From propositional to textual to expressive meanings: some semantic-pragmatic aspects of grammaticalization. In Winfred P. Lehmann and Yakov Malkiel (eds), *Perspectives on Historical Linguistics* (pp. 245–71). Amsterdam and Philadelphia: John Benjamins.
- (1985). Conditional markers. In Haiman 1985b (pp. 289–307).
- (1986). On the origins of *and* and *but* connectives in English. *Studies in Language* 10(1), 137–50.
- (1988). Pragmatic strengthening and grammaticalization. In Axmaker et al. 1988 (pp. 406–16).
- (1989). On the rise of epistemic meanings in English: an example of subjectification in semantic change. *Language* 65(1), 31–55.
- (1992). Syntax. In R. M. Hogg (ed.), *The Cambridge History of the English Language. Volume 1: The Beginnings to 1066* (pp. 168–289). Cambridge: Cambridge University Press.
- (1995a). Subjectification in grammaticalisation. In Susan M. Wright and Dieter Stein (eds), *Subjectivity and Subjectivization: Linguistic Perspectives* (pp. 31–54). Cambridge: Cambridge University Press.

- (1995b). The role of the development of discourse markers in a theory of grammaticalization. Paper given at the 12th International Conference on Historical Linguistics, Manchester, August. Available on line at: <http://www.stanford.edu/~traugott/ect-paperonline.html>
- (forthcoming). Lexicalization and grammaticalization. In A. A. Cruse, F. Hundsnurscher, M. Job, and P. R. Lutzerer (eds), *Lexikologie-Lexicology*. Berlin: Walter de Gruyter.
- Traugott, Elizabeth C. and Dasher, Richard B. (2002). *Regularity in Semantic Change*. Cambridge: Cambridge University Press. (CSL 97.)
- Traugott, Elizabeth C. and Heine, Bernd (eds) (1991a). *Approaches to Grammaticalization. Volume 1*. Amsterdam: John Benjamins.
- (eds) (1991b). *Approaches to Grammaticalization. Volume 2*. Amsterdam: John Benjamins.
- Traugott, Elizabeth C. and König, Ekkehard (1991). The semantics-pragmatics of grammaticalization revisited. In Traugott and Heine 1991a (pp. 189–218).
- Trigger, Bruce G. (1973). The future of archeology is the past. In Charles L. Redman (ed.), *Research and Theory in Current Archeology* (pp. 95–111, and general references, pp. 355–87). New York: Wiley.
- Trudgill, Peter (1974). Linguistic change and diffusion: description and explanation in sociolinguistic dialect geography. *Language in Society* 3, 215–46.
- (1983). *On Dialect: Social and Geographical Perspectives*. New York: New York University Press.
- (1990). *The Dialects of England*. Oxford: Blackwell.
- (1996). Dual-source pidgins and reverse creoloids: northern perspectives on language contact. In Ernst Håkon Jahr and Ingvild Broch (eds), *Language Contact in the Arctic: Northern Pidgins and Contact Languages* (pp. 5–14). Berlin: Mouton de Gruyter. (TIL 88.)
- Trumbach, Randolph (1998). *Sex and the Gender Revolution*. Chicago: University of Chicago Press.
- Tsangelidis, Anastasios (1999). *Will and Tha: A Comparative Study of the Category Future*. Thessaloniki: University Studio Press.
- Tsiapera, Mária (1990). Organic metaphor in early 19th-century linguistics. In Hans-Josef Niederehe and Konrad Koerner (eds), *History and Historiography of Linguistics: Papers from the 4th International Conference on the History of the Language Sciences (ICHoLS IV); Trier, 24–28 August 1987* (pp. 577–87). Amsterdam: John Benjamins. (Studies in the History of the Language Sciences, 51.)
- Tudge, Colin (2000). *The Variety of Life: A Survey and a Celebration of All the Creatures That Have Ever Lived*. Oxford: Oxford University Press.
- Turetzky, Philip (1998). *Time*. London: Routledge. (Problems of Philosophy.)
- Turner, J. R. G. (1986). The genetics of adaptive radiation: a neo-Darwinian theory of punctuational evolution. In Raup and Jablonski 1986 (pp. 83–207).
- Twaddell, William (1938). A note on Old High German umlaut. *Monatshefte für deutschen Unterricht* 30, 177–81.
- Tyndall, John (1897). Vitality. In his *Fragments of Science: A Series of Detached Essays, Addresses, and Reviews. Volume 2* (pp. 46–52). New York: Appleton.
- Ullmann, Stephen (1957). *The Principles of Semantics*. New York: Philosophical Library.
- (1962). *Semantics: An Introduction to the Science of Meaning*. Oxford: Blackwell.
- Ultan, Russell (1978). A typological view of metathesis. In Joseph Greenberg (ed.), *Universals of Human Language. Volume 2: Phonology* (pp. 367–402). Stanford: Stanford University Press.

- Updike, John Hoyer (1966). Harv is plowing now. In *The Music School: Short Stories* (pp. 175–82). New York: Alfred A. Knopf. (Borzoi Books.) [First pub. in a collection of 20 short stories, in a particular sequence, in the *New Yorker*, 1962–6.]
- Valiquette, Philippe L. (1994). Comparative syntax. Posting 5.1484, message 1, to LINGUIST (17 December 1994).
- Vance, Barbara (1995). On the decline of verb movement to Comp in Old and Middle French. In Battye and Roberts 1995 (pp. 173–99).
- Vance, Timothy (1979). Nonsense-word experiments in phonology and their application to *rendaku* in Japanese. Ph.D. dissertation, University of Chicago.
- van Coetsem, Frans (1988). *Loan Phonology and the Two Transfer Types in Language Contact*. Dordrecht and Providence: Foris.
- van der Gaaf, Willem (1904). *The Transition from the Impersonal to the Personal Construction in Middle English*. Heidelberg: Carl Winter. (Anglistische Forschungen, 14.)
- van Ginneken, Jacques (1929). Die Erblichkeit der Lautgesetze. *Indogermanische Forschungen* 45, 1–44.
- van Inwagen, Peter (ed.) (1980). *Time and Cause: Essays Presented to Richard Taylor*. Dordrecht: Reidel.
- van Kemenade, Ans (1987). *Syntactic Case and Morphological Case in the History of English*. Dordrecht: Foris.
- (1997). V2 and embedded topicalization in Old and Middle English. In van Kemenade and Vincent 1997 (pp. 326–52).
- van Kemenade, Ans and Vincent, Nigel (eds) (1997). *Parameters of Morphosyntactic Change*. Cambridge: Cambridge University Press.
- van Marle, J. (1990). Rule-creating creativity: analogy as a synchronic morphological process. In Wolfgang U. Dressler (ed.), *Contemporary Morphology* (pp. 267–73). Berlin: Mouton de Gruyter.
- van Wolde, Ellen (1996). Relating European structuralist semiotics to American Peircean semeiotic. In Vincent M. Colapietro and Thomas M. Olszewsky (eds), *Peirce's Doctrine of Signs: Theory, Applications, and Connections* (pp. 339–49). Berlin and New York: Mouton de Gruyter.
- Van Valen, Leigh M. (1973). New evolutionary law. *Evolutionary Theory* 1(1), 1–30.
- Vaught, Carl G. (1986). Semiotics and the problem of analogy: a critique of Peirce's theory of categories. *Transactions of the Charles S. Peirce Society* 22, 311–26.
- Vendryès, Joseph (1925). *Language: A Linguistic Introduction to History*. New York: Knopf. [Transl. Paul Radin from the 1921 French edn.]
- Vennemann, Theo (1968). German phonology. Ph.D. dissertation, UCLA.
- (1969). Zur synchronischen und diachronischen Phonologie des Deutschen. Manuscript.
- (1972a). Phonetic analogy and conceptual analogy. In Vennemann and Wilbur 1972 (pp. 181–204).
- (1972b). Rule inversion. *Lingua* 29(3), 209–42.
- (1983). Theories of linguistic preferences as a basis for linguistic explanations. *Folia Linguistica Historica* 4, 5–26.
- (1990). Language change as language improvement. In V. Orioles (ed.), *Modelli esplicitivi della diacronia linguistica* (pp. 11–35). Pisa: Gardini.
- (1993). Language change as language improvement. In Jones 1993 (pp. 319–44).
- Vennemann, Theo and Wilbur, Terence H. (eds) (1972). *Schuchardt, the Neogrammarians, and the Transformational Theory of Phonological Change: Four Essays*. Frankfurt: Athenäum.
- Verburg, Pieter A. (1950). The background to the linguistic conceptions of Franz Bopp. *Lingua* 2, 438–68. [Repr. in Sebeok 1966 (vol. 1, pp. 221–50).]

- Vihman, Marilyn May (1980). Sound change and child language. In Elizabeth C. Traugott, Rebecca Labrum, and Susan C. Shepherd (eds), *ICHL 4* (pp. 303–20). Amsterdam: John Benjamins. (CILT 14.)
- (1996). *Phonological Development: The Origins of Language in the Child*. Oxford: Blackwell.
- Vihvelin, K. (1996). What time travelers cannot do. *Philosophical Studies* 81, 315–30.
- Vincent, Diane, Votre, Sebastião, and Laforest, Marty (1993). Grammaticalisation et post-grammaticalisation. *Langues et Linguistique* 19, 71–103.
- Vincent, Nigel B. (1982). The development of the auxiliaries HABERE and ESSE in Romance. In Nigel B. Vincent and Martin Harris (eds), *Studies in the Romance Verb* (pp. 71–96). London: Croom Helm.
- (1985). Il cambiamento sintattico e lo sviluppo dei verbi ausiliari in italiano. In Agostiniani et al. 1985 (pp. 171–4).
- Visser, F. Th. (1963–73). *An Historical Syntax of the English Language*. Leiden: Brill.
- Vogel, Irene (1986). External sandhi rules operating between sentences. In Henning Andersen (ed.), *Sandhi Phenomena in the Languages of Europe* (pp. 55–64). Berlin: Mouton.
- Voltaire (1759). *Candide*. [Ed. with intro., notes, and bibliography Haydn Mason, London: Bristol Classical Press, 1995. In *Candide and Related Texts*, transl. and intro. David Wooten, Indianapolis: Hackett, 2000.]
- von Essen, O. (1964). An acoustic explanation of the sound shift [H] > /u/ and [l] > [j]. In D. Abercrombie (ed.), *In Honour of Daniel Jones* (pp. 53–8). London: Longman.
- von Humboldt, Wilhelm (1825). Über das Entstehen der grammatischen Formen und ihren Einfluß auf die Ideenentwicklung: gelesen in der Academie der Wissenschaften am 17. Januar 1822. *Abhandlungen der königlichen Academie der Wissenschaften zu Berlin* 401–30.
- (1836). *Über die Kawi-Sprache auf der Insel Java, nebst einer Einleitung über die Verschiedenheit des menschlichen Sprachbaues und ihren Einfluß auf die geistige Entwicklung des Menschengeschlechts, Band I: Einleitung*. Berlin: Königliche Akademie der Wissenschaften. [Repr. in *Schriften zur Sprache*, Stuttgart: Reclam, 1973. Transl. P. Heath as *Language: The Diversity of Human Language-Structure and its Influence on the Mental Development of Mankind*, Cambridge: Cambridge University Press, 1988.]
- von Kempelen, W. (1791). *Mechanismus der menschlichen Sprache . . .* Vienna: J. B. Degen.
- von Leibniz, Gottfried Wilhelm and Clarke, Samuel (1717). *A Collection of Papers . . . Which Passed Between the Late Learned Mr. [von] Leibnitz . . . and Dr. Clarke, in the Years 1715 and 1716, Relating to the Principles of Natural Philosophy and Religion*. Bilingual, trans. S. Clarke. London: James Knapton. [English parts ed. Henry Gavin Alexander as *The [von] Leibniz–Clarke Correspondence, Together with Extracts from Newton’s Principia and Opticks*, Manchester: Manchester University Press, 1956. Repr. 1998. French parts ed. Johann Eduard Erdmann as “Recueil de lettres entre [von] Leibniz et Clarke sur Dieu, l’âme, l’espace, la durée, etc.,” in von Leibniz’s *Opera philosophica quae exstant latina, gallica, germanica omnia*, 1–2 (pp. 746–88), Berlin: G. Eichler(i), 1840. Expanded facsimile ed. Renate Vollbrecht, Aalen: Scientia, 1959.]
- von Linné [Linnaeus], Carl (1753). *Species Plantarum*. Stockholm: L. Salvius.
- von Rahden, Wolfert (1992). Ein fast vergessener Aktualist: Georg Christian Füchsel zu Ursprung und Entwicklung der Erde und der Sprache. In Naumann et al. 1992 (pp. 289–322).
- von Ranke, Leopold (1824). *Geschichten der romanischen und germanischen Völker von 1494 bis 1514; Zur Kritik neuerer Geschichtsschreiber*. Leipzig: Duncker und Humblot,

1824. [Repr. as *Sämtliche Werke, Band 33–34* . . . , Leipzig: Duncker und Humblot, 1874. Rev. transl. George Ravenscroft Dennis as *History of the Latin and Teutonic Nations (1494 to 1514)*, London: G. Bell, 1909. Repr. New York: AMS Press, 1976.]
- von Raumer, R. (1863). *Gesammelte sprachwissenschaftliche Schriften*. Frankfurt: Heyder and Zimmer.
- von Röhl, Viktor (Dr Freiherr . . .) et al. (eds) (1917). *Enzyklopädie des Eisenbahnwesens*, 8. Band: *Personentunnel – Schynige Platte-Bahn*. Berlin: Urban and Schwarzenberg. [2nd, completely rev. edn.]
- von Schelling, Friedrich Wilhelm Joseph (1798). *Von der Weltseele: eine Hypothese der höhern Physik zur Erklärung des allgemeinen Organismus*. Hamburg: F. Perthes.
- (1800). *System des transcendentalen Idealismus*. Tübingen: Cotta.
- von Schlegel, August W. (1818). *Observations sur la langue et littérature provençales*. Paris: Librairie Grecque-Latine-Allemande.
- von Schlegel, [Karl Wilhelm] Friedrich (Freiherr . . .). (1808). *Über die Sprache und die Weisheit der Indier: Ein Beitrag zur Begründung der Alterthumskunde*. Heidelberg: Mohr and Zimmer. [Excerpts repr. in *Sprachwissenschaft: der Gang ihrer Entwicklung von der Antike bis zur Gegenwart*. (pp. 160–5), 2nd edn, rev. Hans Arens, Freiburg and Munich: Alber. Excerpts transl. in Lehmann 1967 (pp. 23–8). Repr. Amsterdam: John Benjamins, 1977. (Amsterdam Classics in Linguistics, 1800–1925, 1.)]
- von Slagle, Uhlán (1974). *Language, Thought, and Perception: A Proposed Theory of Meaning*. The Hague: Mouton.
- Voyles, Joseph. (1976). *The Phonology of Old High German*. Wiesbaden: Steiner.
- Vrba, Elisabeth S. (1980). Evolution, species, and fossils: how does life evolve? *South African Journal of Science* 76, 61–84.
- Vrba, Elisabeth S. and Gould, Stephen Jay (1986). The hierarchical expansion of sorting and selection: sorting and selection cannot be equated. *Paleobiology* 217–28.
- Wakslér, Rachelle (1990). A formal account of glide/vowel alternation in prosodic theory. Ph.D. dissertation, Harvard University. [Repr. Ann Arbor, MI: University Microfilms International, 1993.]
- Walker, Leslie J., Richardson, Brian, and Crick, Bernard R. (translators and eds) (1970). *The Discourses*, transl. of Niccolò Machiavelli, *Discorsi sopra la prima deca di Tito Livio* (1517). Harmondsworth: Penguin. [Reissued in Pelican Classics, 1983.]
- Wallerstein, Immanuel Maurice (1974). *The Modern World-System*. [Vol. 1:] *Capitalist Agriculture and the Origins of the European World-Economy in the Sixteenth Century*. New York: Academic Press. (Studies in Social Discontinuity.)
- Wang, William S.-Y. (1969). Competing changes as cause of residue. *Language* 45(1), 9–25. [Repr. in Baldi and Werth 1978 (pp. 236–57).]
- (ed.) (1977). *The Lexicon in Phonological Change*. The Hague: Mouton.
- Wang, William S.-Y. and Cheng, Chin-Chuan (1970). Implementation of phonological change: the Shuang-feng Chinese case. *CLS* 6, no. 1, 552–9. [Repr. in Wang 1977 (pp. 148–58).]
- Wang, William S.-Y. and Lien, Chinfa (1993). Bidirectional diffusion in sound change. In Jones 1993 (pp. 345–400).
- Wanner, Dieter and Cravens, Thomas (1980). Early intervocalic voicing in Tuscan. In Elizabeth C. Traugott, Rebecca Labrum, and Susan C. Shepherd (eds), *ICHL* 4 (pp. 339–47). Amsterdam: John Benjamins. (CILT 14.)
- Wanner, G. (1941). *Die Mundarten des Kantons Schaffhausen: Laut- und Flexionslehre*, ed. H. Wanner. Huber: Frauenfeld.
- Warner, Anthony R. (1983). Review of Lightfoot 1979. *Journal of Linguistics* 19(1), 187–209.

- (1993). *English Auxiliaries: Structure and History*. Cambridge: Cambridge University Press. (CSL 66.)
- (1995). Predicting the progressive passive: parametric change within a lexicalist framework. *Language*, 71(3), 533–57.
- (1997). The structure of parametric change, and V movement in the history of English. In van Kemenade and Vincent 1997 (pp. 380–94).
- (1998). Changes and rates of change in auxiliary *do*. Presented at the First York-Penn Symposium on Syntactic Variation and Change, June 1998.
- Warren, R. M. (forthcoming). Perceptual processing of speech and other perceptual patterns: some similarities and differences. In S. Greenberg and W. Ainsworth (eds), *Listening to Speech: An Auditory Perspective*. Oxford: Oxford University Press.
- Wasow, Thomas (1977). Transformations and the lexicon. In Peter W. Culicover, Thomas Wasow, and Adrian Akmajian (eds), *Formal Syntax* (pp. 327–60). New York: Academic Press.
- (1997). Remarks on grammatical weight. *Language Variation and Change* 9, 81–105.
- Waterman, John T. (1970). *Perspectives in Linguistics*. Chicago: University of Chicago Press. [2nd edn; 1st edn 1963.]
- Watkins, Calvert (1976). Towards Proto-Indo-European syntax: problems and pseudo-problems. In Sanford B. Steever, Carol A. Walker, and Salikoko S. Mufwene (eds), *Papers from the Parasession on Diachronic Syntax* (pp. 306–26). Chicago: CLS.
- (1985). *The American Heritage Dictionary of Indo-European Roots*. Boston: Houghton Mifflin. [2nd edn, 2000.]
- (1990). Etymologies, equations, and comparanda: types and values, and criteria for judgment. In Philip Baldi (ed.), *Linguistic Change and Reconstruction Methodology* (pp. 289–303). Berlin: Mouton de Gruyter. [Also in Baldi 1991 (pp. 289–303).]
- (1995). *How to Kill a Dragon*. Oxford: Oxford University Press.
- Weerman, Fred (1993). The diachronic consequences of first and second language acquisition: the change from OV to VO. *Linguistics* 31, 903–31.
- Weinberg, Gerhard L. (1970–80). *The Foreign Policy of Hitler's Germany. Vol. 1: Diplomatic Revolution in Europe, 1933–1936. Vol. 2: Starting World War II, 1937–1939*. Chicago: University of Chicago Press. [Repr. Atlantic Highlands, NJ: Humanities Press, 1994.]
- (1988). The end of Ranke's history: reflections on the fate of history in the twentieth century. *Syracuse Scholar* 9(1), 51–9. [Repr. in *Germany, Hitler, and World War II: Essays in Modern German and World History* (pp. 325–36), Cambridge: Cambridge University Press, 1995.]
- (1994). *A World at Arms: A Global History of World War II*. Cambridge: Cambridge University Press.
- Weinberg, Steven (1977). *The First Three Minutes: A Modern View of the Universe*. New York: Basic Books. [Updated edn, 1993.]
- Weiner, Jonathan (1995). *The Beak of the Finch: A Story of Evolution in Our Time*. New York: Vintage Books.
- Weinhandl, Ferdinand (ed.) (1960). *Gestalthaftes Sehen – Ergebnisse und Aufgaben der Morphologie: Zum hundertjährigen Geburtstag von Christian von Ehrenfels*. Darmstadt: Wissenschaftliche Buchgesellschaft.
- Weinreich, Uriel (1953). *Languages in Contact: Findings and Problems*. The Hague: Mouton.
- Weinreich, Uriel, Labov, William and Herzog, Marvin I. (1968). Empirical foundations for a theory of language change. In Lehmann and Malkiel 1968 (pp. 95–195).

- Welmers, William E. (1973). *African Language Structures*. Berkeley: University of California Press.
- Wells, Herbert George (1895). *The Time Machine: An Invention*. London: Heinemann. [Repr. in Wells 1960 (pp. 263–335).]
- (1960). *Three Prophetic Novels . . .*, ed. E. F. Bleiler. New York: Dover.
- Wells, Peter S. (1999). *The Barbarians Speak*. Princeton, NJ: Princeton University Press.
- Wells, Rulon S. (1973). Uniformitarianism in linguistics. In Philip Paul Wiener (ed.), *Dictionary of the History of Ideas: Studies of Selected Pivotal Ideas. Volume IV: Psychological Ideas in Antiquity to Zeitgeist* (pp. 423–31). New York: Scribner's.
- (1987). The life and growth of language: metaphors in biology and linguistics. In Hoenigswald and Wiener 1987 (pp. 39–80).
- Wescott, Roger (1976). Protolinguistics: the study of proto-languages as an aid to glossogonic research. In Harnad et al. 1976 (pp. 104–16).
- Weydt, Harald (ed.) (1977). *Aspekte der Modalpartikeln: Studien zur deutschen Abtönung*. Tübingen: Niemeyer. (Konzepte der Sprach- und Literaturwissenschaft, 23.)
- Weymouth, R. F. (1856). On the liquids, especially in relation to certain mutes. *Transactions of the Philological Society* [London], 18–32.
- Wheeler, Benjamin Ide (1887). *Analogy and the Scope of its Application in Language*. Ithaca, NY: Cornell University Press. [Repr. New York: Johnson Reprints, 1965.]
- Wheeler, M. W. (1993). On the hierarchy of naturalness principles in inflectional morphology. *Journal of Linguistics* 29, 95–111.
- Wheeler, Quentin D. and Meier, Rudolf (eds) (2000). *Species Concepts and Phylogenetic Theory: A Debate*. New York: Columbia University Press.
- Whewell, William (1832). Review of vol. 2 (1832) of Lyell 1830–3. *Quarterly Review* 47(93), 103–32. [Pub. anonymously.]
- White, Michael James Denham (1978). *Modes of Speciation*. San Francisco: Freeman.
- Whitney, William Dwight (1867). *Language and the Study of Language: 12 Lectures on the Principles of Linguistic Science*. New York: Scribner's. [Repr. of 6th edn, AMS, 1971. Partial repr. in *Whitney on Language: Selected Writings of William Dwight Whitney*, ed. Michael Silverstein (pp. 7–110), Cambridge, MA: MIT Press, 1971.]
- (1875). *Life and Growth of a Language: An Outline of Linguistic Science*. New York: Appleton.
- Whitrow, Gerald James (1961). *The Natural Philosophy of Time*. London: Nelson. [2nd edn New York: Oxford University Press; Oxford: Clarendon Press, both 1980.]
- (1988). *Time in History: The Evolution of Our General Awareness of Time and Temporal Perspective*. Oxford: Oxford University Press.
- Wiese, Richard (1996a). Phonological versus morphological rules: on German umlaut and ablaut. *Journal of Linguistics* 32, 113–35.
- (1996b). *The Phonology of German*. Oxford: Oxford University Press.
- Wilford, John Noble (1985). *The Riddle of the Dinosaur*. New York: Knopf. (Borzo Books.)
- Willett, Thomas (1988). A cross-linguistic survey of the grammaticization of evidentiality. *Studies in Language* 12(1), 51–97.
- Williams, Donald C. (1951). The myth of passage. *Journal of Philosophy* 48, 457–72. [Repr. in his *Principles of Empirical Realism* (pp. 289–307). Springfield, IL: Charles C. Thomas, 1966. Repr. in Gale 1967 (pp. 98–116).]
- Williams, Drid (1997). *Anthropology and Human Movement: The Study of Dances*. Lanham: Scarecrow Press. (Readings in Anthropology of Human Movement, 1.)
- (2000). *Anthropology and Human Movement: Searching for Origins*. Lanham: Scarecrow Press. (Readings in Anthropology of Human Movement, 2.)

- Williams, Joseph M. (1976). Synaesthetic adjectives: a possible law of semantic change. *Language* 52(2), 461–78.
- Williamson, Kay (1989). Niger–Congo overview. In John Bendor-Samuel (ed.), *The Niger–Congo Languages* (pp. 3–45). Lanham, New York and London: University Press of America.
- Williamson, Peter (1981). Paleontological documentation of speciation in Cenozoic mollusks from Turkana Basin. *Nature* 293, 437–43.
- (1985). Punctuated equilibrium, morphological stasis, and the paleontological documentation of speciation. *Biological Journal of the Linnaean Society of London* 26, 307–24.
- Willis, R. (1830). On the vowel sounds, and on reed organ-pipes. *Transactions, Cambridge Philosophical Society* 3, 229–68.
- Wils, Johannes (1948). In memoriam Jacques van Ginneken (21 April 1877–20 October 1945). *Lingua* 1, 133–9. [Repr. in Sebeok 1966 (pp. 447–54).]
- Wilson, Allan C., Maxson, L. R., and Sarich, V. M. (1974). Two types of molecular evolution: evidence from studies of interspecies hybridization. *Proceedings of the National Academy of Sciences* 71, 2845–7.
- Wilson, Allan C., Ochman, H., and Prager, E. M. (1987). Molecular time scale for evolution. *Trends in Genetics* 5, 231–47.
- Wilson, Leonard George (1967). The origins of Charles Lyell’s uniformitarianism. In Albritton 1967a (pp. 35–62).
- (1972). *Charles Lyell, The Years to 1841: The Revolution in Geology*. New Haven: Yale University Press.
- (1998). Lyell: the man and his times. In Blundell and Scott 1998 (pp. 21–37).
- Wilson, Robert A. (ed.) (1990). *Species: New Interdisciplinary Essays*. Cambridge, MA: MIT Press. (Bradford Books.) [Repr. 1999.]
- Windisch, Ernst (1886). Georg Curtius. *Biographisches Jahrbuch für Altertumskunde* 9, 75–128. [Repr. in Sebeok 1966 (vol. 1, pp. 311–73).]
- Winford, Donald (1997). Re-examining the Caribbean English Creole continua. *World Englishes* 16(2), 233–79.
- Winitz, Harris, Scheib, M. E., and Reeds, James A. (1972). Identification of stops and vowels for the burst portion of /p, t, k/ isolated from conversational speech. *Journal of the Acoustical Society of America* 51, 1309–17.
- Winter, Werner (1969). Analogischer Sprachwandel und semantische Struktur. *Folia Linguistica* III(1/2), 29–45.
- (1984). Reconstructional comparative linguistics and the reconstruction of the syntax of undocumented stages in the development of languages and language families. In Jacek Fisiak (ed.), *Historical Syntax* (pp. 613–25). The Hague: Mouton.
- Winters, Margaret E. (1995). Jerzy Kuryłowicz: the so-called laws of analogy. Transl. and intro. Margaret E. Winters. *Diachronica* 12(1), 113–45.
- Wolff, Roland A. (1981). German past participles and the simplicity metric. *Linguistics* 19(1/2), 3–13.
- Wolfram, Walt and Christian, Donna (1976). *Appalachian Speech*. Washington, DC: Center for Applied Linguistics.
- Wolfram, Walt and Schilling-Estes, Natalie (1996). On the social basis of phonetic resistance: the shifting status of Outer Banks /ay/. *Sociolinguistic Variation-Data, Theory, and Analysis: Selected Papers from NWAV 23 at Stanford [1994]* (pp. 69–82). Stanford: CSLI.
- Wolfram, Walt, Schilling-Estes, Natalie, Hazen, Kirk, and Craig, Christopher (1997). The sociolinguistic complexity of quasi-isolated Southern Coastal communities. In

- Cynthia Bernstein, Thomas Nunnally, and Robin Sabino (eds), *Language Variety in the South Revisited*. University, AL: University of Alabama Press (pp. 173–87).
- Wolpoff, Milford H. (1980). *Paleoanthropology*. New York: Knopf. [Distributed by Random House.]
- (1996–7). *Human Evolution*. New York: McGraw-Hill. (College Custom Series.)
- Wolpoff, Milford H. and Caspari, Rachel (1997). *Race and Human Evolution: A Fatal Attraction*. New York: Simon and Schuster.
- Woolard, Kathryn A. (1989). Language convergence and language death as social processes. In Dorian 1989 (pp. 355–67).
- Wootton, David (2000). Notes on the translation. In Voltaire 1759, trans. 2000 (pp. lxii–lxiv).
- Wright, Sewall (1931). Evolution in Mendelian populations. *Genetics* 16, 97–159. [Repr. in Wright 1986 (pp. 98–160).]
- (1932). The roles of mutation, inbreeding, crossbreeding, and selection in evolution. In Donald F. Jones (ed.), *Proceedings of the 6th International Congress of Genetics* (vol. 1, pp. 356–66). Brooklyn: Brooklyn Botanic Garden. [Repr. in Wright 1986 (pp. 161–71).]
- (1977). *Evolution and the Genetics of Populations: A Treatise. Volume 3: Experimental Results and Evolutionary Deductions*. Chicago: University of Chicago Press.
- (1982). Character change, speciation, and the higher taxa. *Evolution* 36, 427–43.
- (1986). *Evolution: Selected Papers*, ed. William B. Provine. Chicago: University of Chicago Press.
- Wüllner, Franz (1831). *Über Ursprung und Urbedeutung der sprachlichen Formen*. Münster: Theissingsche Buchhandlung.
- Wurff, Wim van der (1997). Deriving object–verb order in Late Middle English. *Journal of Linguistics* 33, 485–509.
- Wurzel, Wolfgang U. (1980). Ways of morphologizing phonological rules. In Fisiak 1980 (pp. 443–62).
- (1984). *Flexionsmorphologie und Natürlichkeit*. Berlin: Akademie-Verlag. [Repr. as Wurzel 1989.]
- (1987). System-dependent morphological naturalness. In Dressler et al. 1987 (pp. 59–96).
- (1988). Analogie: Hermann Paul und die natürliche Morphologie. *Zeitschrift für Germanistik* 9, 537–44.
- (1989). *Inflectional Morphology and Naturalness*, trans. Manfred Schentke. Dordrecht and Boston: Kluwer Academic. [Trans. of Wurzel 1984.]
- (1990). Theoretische Probleme des Sprachwandels. In H. Schmigalla and B. Barschel (eds), *Beiträge zur historischen und vergleichenden Sprachwissenschaft* (pp. 121–35). Jena: Friedrich-Schiller-Universität Jena.
- (1994a). Morphology, natural. In Asher and Simpson 1994 (pp. 2590–8).
- (1994b). Grammatisch initiiertes Wandel. In B. Jeßing (ed.), *Sprachdynamik: Auf dem Weg zu einer Typologie sprachlichen Wandels* (vol. 1, pp. 1–114). Bochum: Brockmeyer.
- (1996a). Alterserscheinungen in der Morphologie. In Norbert Boretzky (ed.), *Natürlichkeitstheorie und Sprachwandel* (pp. 67–91). Bochum: Brockmeyer.
- (1996b). On similarities and differences between inflectional and derivational morphology. *Sprachtypologie und Universalienforschung* 49, 267–79.
- Wyatt, William F., Jr (1970). *Indo-European /a/*. Philadelphia, PA: University of Pennsylvania Press. (Haney Foundation Series, 7.)
- Yaeger-Dror, Malcah (1996). Phonetic evidence for the evolution of lexical classes: the case of a Montreal French vowel shift. In Guy et al. 1996 (pp. 263–87).

- Yule, George (1985). *The Study of Language: An Introduction*. Cambridge: Cambridge University Press.
- Zec, Draga (1993). Rule domains and phonological change. In Sharon Hargus and Ellen M. Kaisse (eds), *Studies in Lexical Phonology* (pp. 365–405). San Diego: Academic Press.
- Zelinsky, Wilbur (1992). *The Cultural Geography of the United States: A Revised Edition*. Englewood Cliffs, NJ: Prentice-Hall.
- Zheng, Guoqiao (1988). The influences of Han on the Mulam language. In Jerold A. Edmondson and David B. Solnit (eds), *Comparative Kadai: Linguistic Studies beyond Tai* (pp. 167–77). Arlington: Summer Institute of Linguistics and the University of Texas at Arlington.
- Zieglschmid, Andreas J. F. (1929). *Zur Entwicklung der Perfektschreibung im Deutschen*. Baltimore, MD: Waverly Press.
- Zinder, L. R. (1979). *Obshchaia fonetika*. Moscow: Vysshaya Shkola. [2nd edn.]
- Zobl, H. (1985). Grammars in search of input and intake. In Gass and Madden 1985 (pp. 329–44).
- Zubritskaya, Katya (1995). Markedness and sound change in OT. *NELS* 25, 249–64.
- (1997). Mechanisms of sound change in Optimality Theory. *Language Variation and Change* 9, 121–48.
- Zwicky, Arnold M. (1982). Stranded *to* and phonological phrasing in English. *Linguistics* 20, 3–57.
- (1985a). Clitics and particles. *Language* 61, 283–305.
- (1985b). Rules of allomorphy and syntax–phonology interactions. *Journal of Linguistics* 21(2), 431–6.
- (1986). Imposed versus inherent feature specifications, and other multiple feature markings. In *Indiana University Linguistics Club 20th Anniversary Volume* (pp. 85–106). Bloomington: Indiana University Linguistics Club.
- (1987). Phonologically conditioned agreement and purely morphological features. [University of California at Santa Cruz] *Syntax Research Center Report SRC-87-06*.
- (1994a). What is a clitic? In Joel A. Nevis, Brian D. Joseph, Dieter Wanner, and Arnold M. Zwicky, *Clitics: A Comprehensive Bibliography 1892–1991* (pp. xii–xx). Amsterdam and Philadelphia: John Benjamins. (Library and Information Sources in Linguistics, 22.)
- (1994b). Morphological metageneralizations: morphology, phonology, and morphophonology. Paper presented at the Kentucky Foreign Language Conference, University of Kentucky, Louisville, April 1994.
- Zwicky, Arnold M. and Pullum, Geoffrey K. (1983). Cliticization versus inflection: English *n't*. *Language* 59, 502–13.

Subject Index

Note: f = figure, ff = and following (pages), n = note, t = table.

- abduction 432, 434
- accentology 172n127
- acoustic studies 671–2
- actualization 536–7, 550n15
- address systems 171n125
- /æ/-Tensing rule 321–6, 351–4, 391, 392, 400n9
- age distribution 380, 384–6, 385f
- agreement-marking constructions 172n126
- allophone 403, 409–11, 413, 414–18, 421n2
- alternations 245–6, 257–9, 405
- analogy 155n68, 247–53, 425–8, 425f, 441–3
 - abduction 432, 434
 - categorialization 429, 430
 - cognitive theory 431, 440n8
 - definition 428–9, 443–5, 593, 601n22
 - gap filling 425f
 - and generative grammar 435–8, 447, 448
 - gestalt theory 426, 429, 430, 438
 - grammaticalization 600n12
 - history of 443–5
 - indexicality 431, 433, 434, 440n14
 - induction 432, 434
 - isomorphism and 429, 439n5
 - lexical diffusion as 314, 315–17, 316t, 320–4, 367n25
 - linguistic signs 426
 - meaning and form 426f
 - measuring and classifying 434–5
 - metaphor and 431–2, 433, 439n7, 440n9
 - morphological and lexical change 425–8, 425f, 426f, 427f, 440n8
 - phonological change 314, 315–17, 316t, 320–4, 367n25
 - similarity relations 427f, 429, 430, 431, 436
 - sound change and 314, 450–6
 - structure 425f
 - syllogisms 432–4
 - tendencies 445–8
 - transposition and 429–31
- anthropological archaeology 104, 151n53
- anthropology 177n143, 208n2
- apparent time assumption 717–18, 732, 735n14
- arbitrariness 553
- archaeology 47, 151n53, 151–2n53, 208n2
- areal stability 289, 304, 306
- aspect 594
- aspiration 147n37
- assimilation 332–5, 333
- asterisk, (non-)use of 93, 94, 166n106
- attestation 14, 15, 16
 - see also* historical corpora
- attrition 704–6, 708
- “automatic vowels” 682
- automatization 603
- autonomy 617–18

- backformation 441
- Bailey’s model 513, 513f
- basic vocabulary lists 291–2
- biclausal structures 538–47
 - see also* clause simplification

- "Big Bang" Theory 32, 419–21
 bleaching 227, 579, 591, 592, 607, 631, 649, 661n2
 blending 442
 borrowing 65, 156–7n70, 220, 267, 271, 288, 449, 532, 691, 692, 696, 698
 see also comparative method; contact-induced change
 broadening 649, 661n5
 see also semantic change

 case marking 594–5
 catastrophe theory 27–8, 31, 51, 73, 148n42, 504, 505, 508n2
 categorialization 414–16, 429, 430
 see also decategorialization
 chain shifts 298
 change(s) 10–11, 37, 38–42, 82–4, 146n36
 vs. diachronic correspondences 152n53
 evolutionary 59
 internal vs. external 120, 123, 708–10
 vs. reanalysis 13, 79
 Russell, Bertrand and 150–1n49
 variation and 370–2
 child language 84, 737–40
 "critical period" 738
 generation gap 738–9
 parameter setting 737–8
 preadolescence 78
 role in language change 120, 122, 174n133, 653–4
 and transmissional discontinuity 49–50, 75
 clause simplification
 Ayul 538–41
 French perfect 541–2
 German perfect 537, 542–5, 546, 551n25
 universal characterization 545–7
 click languages 297, 298
 clines 589, 600n18
 coalescence 588
 code alternation 697–9, 707–8
 code-switching 695–7, 707
 cognacy 187–8, 190t, 217, 221, 267, 278–80
 cognition 431, 440n8
 community grammars 159n81
 comparative method 183–5, 213–15, 669
 application 186–96
 borrowings 220
 cognacy 217
 diffusion 231–2
 false negative results 229–32
 family trees 186
 genetic inference 215
 grammar 228
 grammatical objects 221–5
 limitations 207–8, 220–32
 oddity 228–9
 phonological comparison 217–20
 proto-language (regularities vs. irregularities) 206–7
 regularity assumption 206–7, 217–18, 219–20
 semiotic restriction 216
 similarity condition 218–19, 220
 subgrouping 232–9
 success of 364, 365n12
 as theory of language change 215–20
 uniformitarianism 186
 wave diagrams 186
 see also comparative reconstruction; internal reconstruction
 comparative reconstruction 160n82, 167n108
 cognate searches 187–8, 190t
 complementarity 192
 correspondence sets 189–91, 190t
 deictic particles (Siouan) 194t
 distributional statistics 195–6
 "funny-R problem" (Siouan) 193–5, 210n20
 geographic distribution 191–2
 grammatical reconstruction 225–9
 lexicon 192–3
 morphological reconstruction 187, 197–8
 morphosyntactic reconstruction 198–201
 naturalness 192
 phonetic realism 195
 phonological reconstruction 187, 188–91
 problems 193–4, 195–6
 semantic reconstruction 196–7
 syntactic reconstruction 201–6
 typology 192
 vocabulary 187
 see also grammatical reconstruction; internal reconstruction; morphological reconstruction; morphosyntactic reconstruction; phonological reconstruction; semantic reconstruction; syntactic reconstruction
 compensatory lengthening 360, 368n35
 complementarity 192

- condensation 588
- conditioned merger 245–53
- conditioning 373–6, 546
 grammatical 450–2, 455
 morpholexical 406–7
 phonetic 343, 344, 346–8
 phonological 406–7, 418, 419
- conjunction 567–71
- connectionism 743
- Constant Rate Effect (Hypothesis)
 phonological change 395–8
 syntactic change 511, 513, 514–15, 525, 527n6
see also Uniform Rate Hypothesis
- constraint 120, 175n135, 375–6, 380, 381–2, 392–4, 397, 400n2, 527n6
- construction grammar 625
- constructions 602–3, 624–7, 645
- contact areas
 Arnhem Land 693
 Australia 693
 Balkans 693
see also Sprachbund
- contact-induced change 123–4, 162n94, 687–9, 694–5
 attrition 704–6, 708
 bilingual mixed languages 707
 code alternation 697–9, 707–8
 code-switching 695–7, 707
 vs. contact-language genesis 706–8
 convergence 700, 705, 711n6
 deliberate decision in (and effects on) 703–4
 dialects 120, 123, 159n77, 688
 evidence as source of language change 708–10
 first language acquisition 701–3
 imperfect learning 691–3, 709
 intensity of contact 689
 interference 123–4, 162n94, 687–9, 694–5
 language death 708
 linguistic factors 693–4
 multiple causation 705
 “negotiation” 700
 pidgins and creoles 707, 712n10
 predictions 709
 second language acquisition 700–1
 shift-induced interference 691–2, 693, 712n11
 speaker creativity 709
 Sprachbund 692–3
 systematic effects on recipient language 690–1
see also borrowing; dialectology
- contamination 442
- context 431, 439n7
- context model in grammaticalization 587–8
- contiguity in analogy 431
- corpora *see* historical corpora
- correspondence sets 189–91, 190t, 210n18
- creoles 70–1, 72, 118–19, 578, 583, 629, 707, 712n10
- cue-based theory 500–1, 504, 507
- cultural evolution 64–5
 train cars (as an example of) 45–7, 45f, 46f, 48, 154–5n66
- curse words *see* taboo words
- curvilinear pattern 386
- cyclicality 593
- decategorialization 579, 580, 585, 588, 589, 598, 638, 642
- degrammaticalization 58, 152n63, 477, 593
- deletion vs. insertion 395
- “demes” 158n75, 161n86
- dephoneticization 418
- dephonologization 401–2, 407–8, 411, 412–13, 417
- desemanticization 579, 580, 583, 585, 591, 600n9, 601n20
- diachronic change 86
- diachronic correspondences 13, 56, 151–2n53
- diachronic filter 363f, 364
- diachronic linguistics *see* historical (diachronic) linguistics
- diachronic modularity 344–6
- diachronic pragmatics 116, 171n125
- diachrony vs. synchrony 121–3
- dialectology 713–15
 actuation 714, 733n3
 age grading 719
 amplifiers and barriers 727–9
 cascade diffusion 725–6
 contagious diffusion 726
 contra-hierarchical diffusion 726, 729–33, 730f, 731f
 dialect differentiation 55
 dialects 54, 146n35, 147n37
 early adaptors 729
 embedding 714

- dialectology (*cont'd*)
 focal area 713
 fuzzy set model 723, 734n11
 gravity model (hierarchical model)
 723–7, 724f
 innovators 729
 isoglosses 713, 714
 lects 722–3
 of Martha's Vineyard 719
 of Ocracoke Island 719, 721, 727, 732
 principle of local density 724
 rate of progression 720
 relic areas 723
 S-curve 720
 social networks 728
 spatial diffusion 720
 transition 714, 721
 variation 715–21, 716t
 see also apparent time assumption;
 contact-induced change; family tree
 (model); isoglosses; wave model
 diffusion 59, 123, 139n7, 231–2, 236, 271
 see also dialectology; lexical diffusion;
 wave model
 directionality 152–3n63, 394–5, 656–8
 unidirectionality 484–5, 486–7, 575, 581,
 582, 599n3, 600n13, 627, 630, 633
 discontinuity of language transmission
 44–5, 47, 49–50, 74–9, 76f
 individual grammars 79–81
 and train cars 45–7, 45f, 46f, 48, 154–5n66
 discourse > syntax model (of
 grammaticalization) 630–1
 dislocation constructions 172n126
 dissimilation 331, 340n2, 454, 455
 as sound change 677–8, 678–80
 distant genetic relationship 262–3, 281
 borrowings 267, 271
 chance similarities 267, 274–7
 erroneous morphological analysis 278
 grammatical evidence 268–70
 language continuum 262
 lexical comparison 263–6, 267
 non-cognates 278–80, 282n9
 non-linguistic evidence, relevance of
 277–8
 nursery forms 273–4
 onomatopoeia 272–3
 semantic constraints 271–2
 short forms and unmatched segments
 274
 single etymon as evidence for multiple
 cognates 280–1
 sound correspondences 266–8
 sound-meaning isomorphism 277
 sound symbolism 273
 spurious forms 280
 divergence 589
 diversity 283, 284, 289–91, 308–10
 see also stability
 double base hypothesis *see* grammatical
 competition
 dynamic-chance convergence 276

 E-language 367n25
 elision 681–2
 English 225
 borrowings 271
 change actuation (auxiliary *do*) 513
 compounds 243n29
 Constant Rate Effect 514
 coronal stop deletion (CSD) 375, 379,
 380t, 382, 393–4, 393t
 desemanticization 583–4
 entrenchment (auxiliaries) 619–21
 as head-initial language 516
 iconicity (plural formation) 463–4
 indefinite articles 405
 Middle English expansion of *can* to
 auxiliary status 610–13
 morphologization vs. grammaticalization
 476, 477, 487
 morphosyntactic transparency (verbs)
 464
 nasals 350
 nominal complex-clause connective
 (*instead of*) 636–8
 nominal complex-discourse marker
 (sentence adverbs) 639–42
 as notional concept 41, 42
 noun plurals, internal reconstruction of
 253–6
 phonological reduction 616, 617, 618
 phonological variables (Middle English
 in/ing) 371
 reanalysis of modals 537
 routinization 554
 semantic change in 651, 662n13
 Southeast Midland speech 19
 syllable structure 322
 token frequency (*can*) 605–14, 606t, 608t
 V-to-I-raising 499, 501–2, 505

- variation in speech production 672
 volitional verb-future tense marker 585, 586
 vowel shortening 316–17, 320, 351, 352
 Wessex speech 19
see also Old English; sound changes, examples of; *see also in Language Index* African American Vernacular English; American English; Australian English; Manually Coded English; New York City English; Philadelphia English
 entrenchment 619–21
 entropy 91–2, 168n112
 epenthesis 681, 682t
 ergativity 290, 295
 erosion 579, 580, 585
 etymology, criteria 109, 266
 evolution
 biological vs. linguistic 59–74, 161n85
 cloning 156n70
 of crabs 160n83
 The Darwinian Paradox (Labov) 161n85
 vs. development 81
 of guppies 60, 61
 iguanodon 104
 of lizards 60, 61
 of *Partula* (land snails) 178n148
 Red Queen hypothesis 66
 see also cultural evolution; organicism; punctuated equilibrium
 evolutionary biology 50, 139n17, 327, 328
 evolutionary change 59
 evolutionary gaps 52
 exceptionlessness hypothesis 315, 327, 340, 367n31
 expletives *see* taboo words
 extension 402, 442, 456, 532, 558–61, 579, 600n7, 648–9

 family tree (model) 186, 721
 finiteness problem 349
 fixation 588
 folk etymology 442
 fossil records 52, 55, 56, 59, 157n73
 founder effect/principle 70–1, 72
 four-part analogy 441
 French
 adverbial marker *-ment* 477–8
 biclausal structures (perfect) 541–2
 cognates with English 267
 Constant Rate Effect 514, 515
 discourse-syntax model 631
 dissociation with *pas* 618
 implicature model with *ne* 591–2
 negation 591–2, 618
 syntactic change 506
 V-to-I-raising 500, 501, 502
 grammatical competition 518
 variation in speech production 672
 frequency 602, 604–14, 658–9
 functional constraints 392–4
 functionalism 552–4, 572
 future tense markers 591
 fuzzy set model 723, 734n11

 geminates 360
 gender (as sociolinguistic factor) 389–90
 genders (as grammatical category) 299–303
 generalization 402, 416, 594, 605–7, 613–14, 638, 642
 generational change 416–17
 generative grammar 435–8, 447, 448
 genetic inference 215
 genetic relatedness 240n6
 genetic stability 289, 309
 geology 29, 31, 33–4
 German 16, 85, 371, 477, 502
 alveolar stops, stem-final 245–7
 analogical change in 447, 459n17
 biclausal structures (perfect) 537, 542–5, 546, 551n25
 devoicing of word-final obstruents 245
 final devoicing and final schwa-loss 448
 as head-final language 516
 morphologization of participial *ge-* 406–7
 morphosyntactic transparency (in verbs) 464
 St Gall records of Old High German 18
 transfer model in 587–8
 and Turkish intonation patterns in L1 acquisition 702
 umlaut in 19, 409–13
 gestalt theory 426, 429, 430, 438
 glottochronology 117, 173n129, 230, 264
 gradualism 53, 58, 68, 160n83
 grammar 228
 grammatical comparison 268–70
 grammatical competition 510, 516–19
 grammatical conditioning 450–2, 455
 grammatical objects 221–5

- grammatical reconstruction 225–9
 via grammaticalization 226
 morphology 228–9
 oddity 228–9
 word order typology (consistency) 226–7
 see also bleaching
- grammaticalization 58, 226, 575–81, 600n6, 601n23
 analogy 600n12
 autonomy 617–18
 bleaching 579, 591, 592, 607, 631
 constructions 602–3, 624–7, 645
 context model 587–8
 decategorialization 579, 580, 585, 588, 642
 degrammaticalization 58, 152n63, 477, 593
 desemantization 579, 580, 583, 585, 591, 600n9, 601n20
 directionality in 656–8
 English auxiliaries 619–21
 English *can* 605–14, 606t, 608t
 entrenchment 619–21
 erosion 579, 580, 585
 extension 579, 600n7
 findings 594–6
 framework 578–81
 frequency 602, 604–14, 658–9
 generalization 594, 605–7, 613–14, 638, 642
 Greek *θa*-future 584–6
 historical reconstruction 596–8
 implicature model 591, 592
 loss-and-gain model 591, 592
 meaning change 634–5, 635f
 metaphor 586–7
 vs. morphologization 472–3, 475–9
 nominal complex to clause connective (with *instead of*) 636–8, 647n11
 nominal complex to discourse marker 638–42, 647n11
 Old English 582, 605–14, 608t, 623n6, 633
 overlap model 579, 590
 parameters 628t
 phonological fusion 617
 phonological reduction 615–17
 pragmatic functions 618
 prediction 598–9, 601n25
 repetition 603–4, 621–2
 reversal *see* degrammaticalization
- ritualization 603
 root possibility 613–14
 and semantic change 654–6
 semantic-pragmatic issues 630–6
 structural issues 627–30
 structural properties 588–92
 terminological issues 577, 592–4
 token frequency 604–5, 618, 619
 transfer model 586–8
 type frequency 604–5
 unidirectionality 483–4, 581, 582, 599n3, 600n13, 627, 630
- grammaticalization studies 79–81, 449–50, 575, 597
- grammaticalization theory 577, 578, 583, 597, 598, 642–5
 criticisms of 13, 57, 58, 66, 74, 79, 121, 475–8, 483–4, 581–4
- grams 602, 622n1, 622n2
- Grassman's law 678, 680
- gravity model (hierarchical model) 723–7, 724f
- Greek 205
 Cappadocia dialect 690
 θa-future (in Modern Greek) 475, 479–84, 584–6
 Ionic Greek 147n37
 Modern Greek genitive and Natural Morphology 469
 see also in Language Index Ancient Greek
- habituation 603, 604, 605
- Head-driven Phrase Structure Grammar (HPSG)
 linguistic signs 221–2, 242n20
- Heir-Apparent Principle 546–7
- historians xiii–xiv, 107
- historical change 86
- historical corpora 14, 15, 16, 515, 527n10, 550n21, 551n23
 see also historical evidence; philological methodology
- historical (diachronic) linguistics 85–9, 152n61, 177n142, 179n149, 362–4
- historical evidence 14–15
 accidental aspects 15, 142n25
 accidental gaps 15, 40–2
 documentary evidence 140n20, 143n28
 fossil records 52, 55, 56, 59, 157n73
 gaps 15, 19–20, 40–2
 imperfect records 19–23

- recoverability 112–13
 St Gall records 18
 sound recordings 140n20
 Vindolanda records 18
see also historical corpora; philological
 methodology
 historical linguistics 85–9, 127–30
 historical pragmatics 116, 171n125
 history 107–8
 HPSG *see* Head-driven Phrase Structure
 Grammar
 hypercorrection 356, 357, 415, 416, 582, 677,
 678
 hypocorrection 415, 678

 iconicity 184, 431, 463
 implicational universals 327
 implicature model 591, 592
 inclusive/exclusive oppositions 303–4
 indexicality 431, 433, 434, 440n14, 465–6
 individual speakers 73, 78, 153n63
 Indo-European 204, 205, 281–2n3
 genders 300
 morphotactic transparency (instability of
 infixes) 464–5
 predicative possession 597
 proto-language (Proto-Indo-European)
 208, 474, 488n8
 stability in 285t
 Indo-European society 174n132
 informational maximalism 23, 35, 37
 inherent variability 378–81
 inheritance 286, 287, 288, 291
 innovations 13, 44, 77, 78, 152n58
 independent 120
 insertion (vs. deletion) 395
 instrumental phonetics 670, 672
 inter-linguistic durability 286
 internal reconstruction 168n116, 244–5, 596
 alternations resulting from conditioned
 merger 245–53
 alternations resulting from secondary
 split 253–7
 intonation 117, 172n126
 irregularity 442, 444, 457
 isoglosses 713, 714
 isomorphism 277, 429, 439n5

 language acquisition 345–6, 348, 365n9,
 390, 419, 626, 700–3
 language transmission 286–7, 291
 see also child language
 language age 310n4
 language change *see* linguistic change
 language death 708
 laryngeal theory 133–4n5
 Lautgesetz (sound change) vs. Lautwechsel
 (sporadic sound change) 343, 347,
 364n2
 layering 589
 lectal variability 209n14
 lects 722–3
 leveling 442, 445
 lexemes 627
 lexical change 652–4
 lexical comparison 263–6, 267
 basic vocabulary 263–4
 glottochronology 264
 multilateral (mass) comparison 264–6
 lexical diffusion 115, 313–14, 453, 454, 455
 as analogy 315–17, 316t, 320–4, 367n25
 diachronic modularity 344–5, 365n11
 features subject to 324–6
 Labov's view on 325, 453
 and regular sound change 390–2
 underspecification 317–20, 350–7, 356,
 367n25
 variationist approach 390–2
 lexicalist theories 505
 lexicalization 402
 lexicon 133n3, 192–3
 lexicostatistics 173n129
 linguistic change 84–5, 87, 120, 651
 causation 124, 669ff, 687ff, 736ff
 evolutionary approach 161n85
 existence of 43–4
 individual innovation vs. group-wide
 spread 138–9n17
 time course 511–15
 linguistic diffusion 714, 719
 see also contact-induced change;
 dialectology; diffusion
 linguistic interference *see* contact-induced
 change
 linguistic kinship *see* distant genetic
 relationship
 linguistic reconstruction(s) 92, 93–5, 102–14,
 115–19
 see also comparative reconstruction

- linguistic signs 221–2, 242n20, 426
 linguistic theory 120, 127, 174n134, 313ff,
 343ff, 401ff, 495ff, 509ff
 loanwords *see* borrowing
 localism 576
 loss 287
 loss-and-gain model 591, 592
- meaning and form 426f
 melioration 650
see also semantic change
 mental grammars 495
 metaphor 79, 81, 586–7
 and analogy 431–2, 433, 439n7, 440n9
 and grammaticalization 586–7
 metaphoric extension 648–9
see also semantic change
 metathesis 340n2, 454, 455, 681
 metonymic extension 649
 metonymy 431
 migration 59, 139n17
see also population history
 Minimalism framework 516
 modality 594
 modeling
 conditioning 373–6
 social conditions 376–7
 sound change 372–7
 modularism 438, 440n16
 morpheme 472, 474, 477, 484, 485, 599n5
 morpheme canons 296–8
 Morpheme Structure Constraints (MSC)
 319, 341n8
 morpholexicalization 407–8
 morphological change 449–50, 471
 grammar-external factors 470–1
see also naturalness
 morphological reconstruction 197–8
 morphological segmentation 278
 morphological structure 259n7
 morphologization 404–8, 472–5, 485–6,
 488n4, 490n18
 demorphologization 485, 492n36
 desyntacticizing and dephonologizing
 473
 vs. grammaticalization 472–3, 475–9,
 491n24
 Greek future 479–84, 491n31, 491n32–3
 morphemes 490n21, 492n40
 morphological elements 478–9, 489n16
 Oscan locative 479
 vs. phonogenesis 477
 phonologization 492n37
 and reconstruction 486–7, 492n40
 unidirectionality 484–5, 486–7
 morphology 5, 132n2, 133n3, 228–9, 462,
 472
 morphophonemic extension 442
 morphosyntactic change 577
 morphosyntactic reconstruction 198–201
 morphosyntax 65–6
 MSC *see* Morpheme Structure Constraints
 multilateral (mass) comparison 264–6, 267,
 275
 mutations (in Celtic) 405–6
- narrowing 649, 661n5
see also semantic change
 naturalness 192
 grammar-external factors 470–1
 grammar-initiated change 462
 indexicality parameter 465–6
 morphological change 461–2
 morphotactic transparency 464
 preference theory 463
 sound change 332–9, 361–2
 suppletion 468
 syntax 205–6
 system-dependent 468–70
 system-independent 463–7
 type-adequacy 467–8, 469–70
 (bi-)uniqueness 466
 universal naturalness 463–7, 469–70
 word-base preference 465
- Neogrammarian doctrine 313, 327, 339,
 343–68, 390, 421
 and analogy 442, 444, 451, 452, 453–4,
 455
see also sound change
 nominal complex-clause connective (*instead*
of) 636–8, 647n11
 nominal complex-discourse marker 638–42,
 647n11
 nominality 594
 non-linguistic comparison 277–8
 Northern Cities Chain Shift 397
 numeral classifiers (in Pacific Rim
 languages) 299
 nursery forms 273–4
- obligatorification (in grammaticalization)
 588

- obstruents, word-final, devoicing (German) 245
- “Ockham’s razor” 25
- Ocracoke Island 719, 721, 727, 732
- Old English
- finite verb position 519–24, 523f, 523t, 527n14
 - frequency of *can/cunnan* 605–14t, 608t, 623n6
 - grammatical competition (verbs and complements) 517
 - indirect passives 15, 141n23
 - metathesis 681
 - OV-VO order 510
 - temporal misalignment of treatment 20
- “old time synchrony” 86, 171n125
- onomatopes 208n4
- onomatopoeia 272–3
- opacity 659, 666n38
- Optimality Theory 120, 175n135, 382–3, 400n2, 409, 431, 743
- optimization 352
- organicism 6–10, 79, 135–6n9, 136–7n11, 155n69, 158n75
- orthogenesis 327
- overgeneralization 356, 367n29
- overlap model 579, 590
- Paleogrammarians 106
- paleontology 55, 59, 104, 105, 118
- uniformitarian principles 150n47
- Papua New Guinea 209n9
- parallels between linguistics and other sciences
- biology 161n85
 - physics 97–102
- see also* evolutionary biology; organicism
- parsimony principle 24–5, 35, 36
- see also* “Ockham’s razor”
- pejoration 650
- peripatric speciation 50–8, 59, 72
- persistence 589
- personal pronouns (in Nakh-Daghestanian) 292–5, 310n6
- philological methodology 41, 152n53
- see also* historical corpora; historical evidence
- phonemes 403, 415
- phonemic split 253–7, 328, 329, 409, 411, 417–19
- phonemicization 411, 412, 413, 417
- phonetic change vs. phonological change 377–83
- inherent variability 378–81
 - Optimality Theory 382–3
 - phonology of the speech community 381–2
- see also* sound change
- phonetic conditioning 343, 344, 346–8
- phonetic distance 413, 414–17
- phonetic realism 195
- phonetic similarity 413, 414
- phonetics (as science) 669–71
- phonogenesis 477, 492n36
- phonological change vs. phonetic change *see* phonetic change vs. phonological change
- phonological comparison 217–20
- phonological fusion 617
- phonological reconstruction 187, 188–91
- phonological reduction 615–17
- phonological rules, life cycle 330–2
- phonologization 485, 492n37
- phonology 133n3, 381–2, 669
- pidgins 118–19, 144n29, 241n13, 578, 707, 712n10
- population history 51f, 72, 76f
- Caucasus 306
 - Pacific Rim 306–8, 307t, 310n6
- pragmatics 80, 116, 117, 171n124, 171n125, 618
- predictions 179n149, 598–9, 601n25, 709
- preference theory 461, 463, 465
- prescriptivism 176n139
- priming effect 328, 329, 330, 360, 361, 368n35
- Principles and Parameters framework 509, 511, 516, 525
- see also* syntactic change, parameter resetting
- pronominal paradigms (Nakh-Daghestanian) 294t
- prosody 117, 172n127
- Proto-Germanic strong verbs 257–9
- proto-languages 93–4, 110–11, 166–7n108, 169n118
- regularities vs. irregularities 206–7
- prototype theory 664n20
- psycholinguistics 736–7
- child language 737–40
- connectionism 743
- cross-category harmony 742
- speech processing 740–3

- punctuated equilibrium 50–8, 63, 65, 66,
73, 157n71, 160n83
see also evolution
- reanalysis
vs. change 13, 79
class distribution 388–9
grammaticalization 592–3, 629, 638, 642
resistance to 388
semantic change 650–2
in syntactic change 532, 536–7, 554–8
see also innovations
- recessive features 289, 299
- recomposition 442
- reduction of form (in grammaticalization)
603
- redundant features 329, 341n17
- regularity 343, 344, 346–8, 351, 365n12,
367n30
vs. lexical diffusion 390–2
variationist approach 390–2
see also exceptionlessness hypothesis;
Neogrammarian doctrine; regularity
assumption; sound change
- regularity assumption 206–7, 217–20,
219–20, 223
- rendaku* rule 124
- repetition 603–4, 621–2
- replication 156–7n70
- resonance 292, 294, 295
- rhotacism (in Latin) 250–3
- rhotic/lateral resonants 193–5, 210n20
- Roman Empire 164–5n100
- routinization 554–8
- S-curve 507, 512–13, 512f, 720
- secondary split 253–7, 328, 329, 411ff
- selection 286, 288
- semantic change 597, 638, 642, 648–50,
665n22
crowding out 662n13
and lexical change 652–3
role of children 653–4
- semantic comparison 271–2
- semantic field theory 665n22
- semantic-pragmatic weakening 631–6
- semantic promiscuity 272
- semantic reconstruction 196–7
- semiotic restriction 216, 219
- sequential voicing (*rendaku*) 124
- shared aberrancy 266, 270
- short forms 274
- signed languages 504
- similarity condition 218–19, 220, 223, 266,
267, 274–7
nursery forms 273–4
- simplification 352
- social class distribution 386–9
- social mobility 63–4
- social networks 62–3, 728
- sociolinguistic approaches to linguistic
change
/æ/-Tensing 321–6, 351–4, 391, 392,
400n9
age as a variable 44
change in progress 129, 177n145, 416ff
community grammars 159n81
Labov's Martha's Vineyard study 41, 736
Northern Cities Chain Shift 397
overgeneralization 410
Philadelphia English 17, 321–6, 351–4,
391, 392, 400n9
post-vocalic /r/ 397
sex as a sociolinguistic variable 389–90
social class 386
sound change 209n8, 369ff, 452, 453, 455
speech communities 78
speech styles 72
variation 369ff
working-class speech 71
see also dialectology; gender; S-curve
- sound change
analogy and 314, 450–6
"Big Bang" model 419–21
as "blind" operation 326–30, 357, 359,
367n30
causes 348–50, 366n18, 671f
compensatory lengthening 360, 368n35
conditioned merger 245–53
in communities 260n9
diachronic modularity 344–6
dissimilation 454, 455, 677–8, 678–80
elision 681–2
epenthesis 681, 682t
grammatical conditioning 450–2, 455
hypercorrection 677, 678
hypocorrection 678
Lautgesetz vs. *Lautwechsel* 343, 347, 364n2
lexical diffusion 313–14, 315–26, 390–2
mergers 378–81, 381
metathesis 454, 455, 681
modeling 372–7

- naturalness 332–9, 361–2
 typology of assimilation 332–5
 nature of 345f
 Neogrammarian controversy 453–4
 Neogrammarian hypothesis 209n6,
 343–64, 367n25
 phonetic conditioning 343, 344, 346–8
 phonological basis of 313–15
 phonological rule development as a “life
 cycle” 330–2, 402
 regularity 184, 244, 344, 365n12, 367n30,
 453, 459n26
 vs. lexical diffusion 390–2
 secondary split 253–7, 328, 329, 411ff
 social distribution 383–90
 stability 287
 structure-dependence 315, 326–32,
 357–61
 synchronic phonetic variation 671–2
 variation in speech perception 673–5,
 674t, 676–7
 variation in speech production 672–3,
 675–6
 variationist approaches 370–2
 vowel fronting 408
 vowel shifts 335–9
 vowel shortening 316–17, 320, 351, 352
see also conditioning; Neogrammarian
 doctrine; underspecification
- sound changes, examples of
 */a/-fronting (in pre-Greek) 247–9
 /a/ tensing and raising (in English) 370,
 396
 /æ/-Tensing (in English) 321–6, 351–4,
 391, 392
 assimilation 333–5, 677–8
 “automatic vowels” 682
 Grassman’s law 678, 680
 Great Vowel Shift (in English) 63, 336–9
 /h/-loss (in American English) 717–18,
 718t, 721–2, 734n6
 mutations in Celtic 405–6
 /n/-loss in Modern Greek 481, 483
 North Germanic sound changes 327
 Northern Cities Chain Shift 397
 palatalizations in Slavic 417–19
 r-insertion in English 459n26
 phonetic conditioning 343, 346–8
 variationist approach 390–2
 rhotacism of intervocalic *s (in Latin)
 250–3
- sequential voicing (*rendaku*) in Japanese
 124
 ū-shortening in English 453
 sound correspondences 266–8
 sound-meaning isomorphism 277
 sound recordings 140n20
 sound symbolism 273
 Spanish 204, 616
 automatic vowel 682
 grammatical competition 518
 morphologization of adverbial *-mente*
 479, 488n6
 morphologization of “feminine” *el* 407–8
 phonological reduction 616
 specialization 589
 speciation 51, 53–4, 157n73, 158n75,
 160n83, 178n148
 peripatric 50–8, 59, 72
 speech communities 78, 381–2
 speech perception 673–5, 674t, 676–7
 speech processing 740–3
 speech production 672–3, 675–6
 speech styles 71, 144n30
 Sprachbund 692–3
 spread 59, 123, 139n7, 231–2, 236, 271
 spurious forms 280
 stability 65–6, 86, 283–91, 308–10
 acquisition 287, 291
 basic vocabulary survey 291–2
 contact-induced 124
 cross-linguistic 286
 and diversity theory 289–91
 ergativity and 295
 genders and 299–303, 301t, 302t
 inclusive/exclusive and 303–4
 Indo-European 285t
 inheritance 286–7, 291
 inter-linguistic 286
 language families 285–6
 numeral classifiers and 299
 personal pronouns and 292–5, 293t, 294t,
 310n6
 phonetics/phonology and 295–8
 chain shifts of vowels 298
 segments 295–6
 syllable/morpheme canons 296–8
 in transmission 286–91
 types 284–6
 viability 289, 307
 word order and 304–5
see also areal stability; diversity; stasis

- stasis 51, 57, 61–2, 63, 65
 stress assignment 351, 367n23
 structure-dependence 315, 326–32, 357–61
 subgrouping 232–9
 submerged features 269, 270
 substantive reduction 615
 substratum 288
 suppletions 109
 survival analysis 290
 SVO order 286, 305
 syllable canons 296–8
 syllogisms 432–4
 synchronic analysis 121
 synchronic morphophonemic analysis
 240n3
 synchrony vs. diachrony 121–3, 176n138
 syntactic change(s) 125, 472ff, 495ff, 509ff,
 529ff, 552ff, 575ff
 actualization 536–7, 550n15
 Aleut clause structure 561–7
 catastrophe theory 504, 505, 508n2
 characterization and explanation 530–1
 clause simplification 538–47
 conjunction 567–71
 Constant Rate Effect 511, 513, 514–15,
 525, 527n6
 cross-linguistic comparison 531–2, 547–8
 cue-based theory 500–1, 504, 507
 deaf children 504
 extension 532, 558–61
 functional approaches 552–4, 572
 Georgian *unda* 533–6, 537, 546, 549n8
 goals of study 529–30
 grammatical approaches 495–6
 grammatical competition 510, 516–19
 lexicalist theories 505
 and Manually Coded English (MCE)
 504
 Minimalist framework 516
 Old English finite verb position 519–24,
 523f, 527n14
 OV-VO order 510
 parameter resetting 496–8, 500, 502, 503,
 506, 507
 Principles and Parameters framework
 509, 511, 516, 525
 reanalysis 532, 536–7, 554–8
 routinization 554–8
 signed languages 504
 syntactic doublets 537
 triggers 500
 V-to-I raising 498–503, 505
 variationist approaches 509–11
 Yup'ik past contemporative 558–61,
 572n3
 Yup'ik subordinative 554–8, 572n3
 see also grammaticalization; syntactic
 reconstruction
 syntactic doublets 537
 syntactic reconstruction 187, 201–6
 see also comparative reconstruction
 syntax 132n2, 133n3
 naturalness in 205–6

 taboo words 16
 taxonomic phonetics 669–71
 temporal reduction 615
 tense 594
 tenseness 336–9
 see also /æ/-Tensing rule
 time 11–14, 32, 89–114, 121, 146n36,
 167n109, 230–1
 The Time Machine (Wells) 96
 time travel 97, 99, 101, 168n112
 token change *see* type/token distinction
 tonogenesis 328, 360
 tonology 172–3n128
 transfer model 586–8
 transmission probabilities 287–9, 288t, 309
 transparency principle 530
 see also syntactic change
 tree model 721
 type/token distinction 41, 43–8
 typology 21–2, 110, 153n64
 assimilation 332–5
 comparative method 192, 210n19
 word order 226–7

 undergeneralization 367n29
 underspecification
 lexical diffusion 317–20, 350–7, 356,
 367n25
 and phonological change 350–7, 413
 theoretical options 318t, 342n20
 Uniform Rate Hypothesis 140–1n21
 see also Constant Rate Effect
 uniformitarianism 28–9, 30, 186, 371,
 399n1, 734n8
 and linguistic change 22, 23–6, 35, 36,
 148–9n44, 150n47
 uniformity 26–31, 36
 unmatched segments 274

- V-to-I raising 498–503, 505
 - see also* syntax
- variable rules 373, 374
- variation/selection model 328, 329
- variationist approaches 44, 369–70, 390–8, 509–11
- verb-final order 305
- verb-initial order 305
- verb raising 520, 528n17
- viability 289
- vowel shifts 335–9, 342n21
- vowel shortening 316–17, 320, 351, 352
- vowel-fronting 408
- wave diagrams 186
- wave model 186, 713–14, 714f, 721, 733n1
- word order 224, 226–7, 304–5, 595
 - see also* SVO order; syntactic change;
 - verb-final order; verb-initial order
- written language 144n30

Name Index

Note: f = figure, n = note, t = table.

- Aarsleff, Hans 34–5, 134n6
Aavik, Johannes 176n140
Abraham, Werner 633
Achilles 414
Acson, Veneeta 469–70
Acton, (Lord) *see* Dalberg-Acton, John E. E.
Adam, Lucien 9
Adams, Douglas 101
Adams, Douglas Q. 174n132
Adams, M. P. 515, 518
Adams, Marilyn McCord 148n41
Ælfric 636–7
Aelian(us), Claudius 143n28
Agathon 11, 138n14
Ager, Derek 148n42
Aharonov, Yakir 98
Aiello, Leslie C. 116
Aitchison, Jean 10, 77, 120, 122, 176n140,
177n142, 400n4, 471, 654, 662n8, 738–41
Albritton, Claude C., Jr 148n42, 149n45
Aleksiev, Mikhail E. 302t
Alexander, Ronelle 172n127
Alfred (“the Great,” king of the West
Saxons) 164n99
Algeo, John 717
Allen, Cynthia 122, 554
Allen, W. Sidney 147n37, 186, 210n19,
686n5
Allerton, David J. 639
Altenderfer, Mark 154n65
Altmann, Gabriel H. 512
in Altmann et al. 512
Alvarez, Luis W. 31
Alvarez, Walter 31
in Alvarez et al. 31
Amador, Mariscela 686
Amsterdamska, Olga 134n6
Anandan, Jeeva S.
in Aharonov et al. 98
Andersen, Henning 12–13, 44, 75–6,
144n30, 417–18, 440n12, 459n20, 488n4,
626, 661n6, 662n11, 737
Anderson, Edgar 72
Anderson, James M. 6, 134n6
Anderson, John M. 576, 686n5
Anderson, Stephen R. 134n6, 329, 360,
368n35, 404, 415, 447, 487, 488n3–4,
489n11
Anderson, Wyatt W.
in Giddings et al. 53
Andocides 250
Andresen, Julie Tetel 134n6
Andrews, Avery 86
Anglin, Jeremy M. 664n20
Anstey, Robert L. 160n83
Antinucci, Francesco 741
Anttila, Arto 175n135
Anttila, Raimo 117, 120, 124–5, 153n63,
168–9n116, 173n129, 240n7, 242n23,
283, 409, 425–8, 430–4, 437, 439n4,
439n7, 440n7–8, 440n14, 440n17, 444–5,
450–1, 457n1, 461, 471n5, 481, 597, 621
Aquinas, Thomas (St) 24
Archangeli, Diane 340n5, 340n7, 743

- Arends, Jacques 578
 Arens, Hans 134n6
 Aristotle 10, 24–5, 34–6, 425, 432, 440n8
 Arlotto, Anthony 168–9n116, 446, 661n1
 Armstrong, David F. 116
 Arnold, A. J.
 in Hunter et al. 68
 Arnovick, Leslie K. 171n125
 Aronoff, Mark 464
 Asaro, F. 31
 in Alvarez et al. 31
 Ash, Roberta 23
 Asher, Ronald E. 134n6, 173n128
 Åström, Paul 153n64
 Auden, Wystan H. 115
 Auger, Julie 124, 157n70, 172n126, 416, 486,
 524
 Augustinus, Aurelius (St Augustine, bishop
 of Hippo) 89–90, 123, 165n101
 Aureol, Peter 25
 Auroux, Sylvain 134n6
 Auxerre, William of 138n14
 Avise, John C. 160–1n83
 Ayala, Francisco 157n71
 Ayto, John 739

 Backus, Albert M. (Ad) 695, 697–8, 711n4
 Baer, Thomas
 in Löfqvist et al. 173n128, 670
 Baggioni, Daniel xv
 Bahn, Paul 63, 145n31
 Bailey, Charles-James N. 321, 396, 461, 512,
 513f, 716, 720, 733n1, 733–4n11
 Bailey, Cyril 11
 Bailey, Guy 17, 386, 716, 718, 725–9, 727–9,
 730–1f, 732, 738, 741
 Bailyn, Bernard 64, 142n25
 Baker, Mark C. 507, 578
 Baker, Paul T.
 in Harrison et al. 70
 Baker, Victor R. 30–1
 Bakker, Peter 707
 Bakker, Robert T. 150n47
 Ball, J.
 in Lighter et al. 131n1
 Bally, Charles 175–6n138, 450
 Bammesberger, Alfred 133–4n5
 Bănescu, Nicolae 481, 491n32
 Barber, Charles L. 177n143
 Barbosa, Pilar 141n21
 Barbour, Julian B. 167n110

 Barigozzi, Claudio 53
 Baron, Naomi S. 75
 Barrère, Albert 131n1
 Barrett, Martyn 661n3, 664n20
 Barry, Marion 641
 Bartholomew, M. 149n45
 Bartlett, John R. 131n1
 Barton, Nick H. 157n71
 Baskerville, William of (Guglielmo da)
 148n41
 Baskerville(s) (family) 148n41
 Baskett, William D. 54
 Bately, Janet 164n99, 526
 Bates, Elizabeth 174n133
 Bateson, William 138–9n17
 Bauer, Brigitte L. M. 506
 Bauer, Laurie 177n143
 Beaken, Mike 116
 Beale, Paul 132n1
 Beard, Charles A. 14
 Becker, Thomas 435
 Beckmann, Jan P. 148n41
 Beddor, Patrice Speeter 675, 677
 Beethoven, Ludwig van xiv, xviiiin4
 Bell, Alexander Melville 669
 Bell, Allen 371
 Bello, Andrés 407–8
 Bencze, Lóránt 439n7
 Benedict, Paul K. 272
 Benét, William Rose 164n100
 Bengtson, John 264
 Benton, Michael J. 160n83
 Benveniste, Émile 174n132, 227, 545
 Bēowulf (“Bee Wolf”) 86, 164n99
 Berggren, William A. 148n42
 Bergsland, Knut 174n131, 230, 562–4,
 566
 Berlocher, Stewart H. 53
 Bernstein, Cynthia 721
 Bernstein, Leonard 70
 Berwick, Robert C. 507
 Best, Karl-Heinz 434, 439n3, 440n17, 443,
 445, 457n4–5
 Besten, Hans den 528n17
 Bethin, Christina Y. 172n127
 Bever, Thomas G. 741
 Bhandarkar, Ramkrishna G. 443
 Bickel, Balthasar 292, 309
 Bickerton, Derek 116, 138–9n17, 504,
 664n17, 712n10
 Biggs, Bruce 232

- Billings, Josh (= Henry Wheeler Shaw) 165n100
- Bindseil, Heinrich E. 670
- Bisang, Walter 589
- Bittner, Andreas 469, 471n3
- Blackburn, Bonnie 137n12
- Blackham, Harold J. 178n146
- Blackstone, Neil W.
in Cunningham et al. 160n83
- Bladon, R. Anthony W. 672
- Blake, Barry J. 655, 665n24
- Blakemore, Diane 633
- Blevins, Juliette 662n6, 681
- Bligh, William (Captain) 38, 119
- Bloch, Bernard
in Kurath et al. xv
- Blom, Jan P. 695
- Bloomer, Robert 471n3
- Bloomfield, Leonard 40, 62, 151n53,
166n105, 170–1n121, 176n138, 208,
256–7, 366n18, 403, 409, 414, 444, 451,
458n7, 677, 690, 715, 724
- Blum, Harold F. 92
- Bobaljik, Jonathan D. 509
- Boehner, Philotheus 148n41
- Boethius, Anicius Manlius Severinus 641
- Bogoras, Waldemar 570
- Böhtlingk, Otto xvi
- Boller, Paul F., Jr. 89
- Boltzmann, Ludwig 91, 168n112
- Bomhard, Allan R. 272
- Bonaparte (Buonaparte), Napoléon (I) 131
- Bonaventure (St; Cardinal, né Giovanni di Fidenza) 24
- Bonfante, Giuliano 7, 9
- Boorstin, Daniel J. 169–70n119
- Bopp, Franz 6–8, 10, 134–5n8, 137n11, 449,
553, 576
- Boretzky, Norbert 444, 470
- Borges, Jorge Luis 127
- Bosch, Peter 439n7
- Boulnois, John 23–4
- Bourke, Vincent J. 89
- Bowden, John 599
- Bowler, Peter 149n45
- Boyd, Sally 379–81, 738
- Boyland, Joyce Tang 603, 617
- Boyle, Robert 685
- Bradwardine, Thomas (archbishop of Canterbury) 138n14
- Braithwaite, Richard B. 162n91
- Bréal, Michel 148n43, 450
- Bredsdorff, Jakob H. 686n5
- Brenzinger, Matthias 708
- Bresnan, Joan 491n26
- Brett, Carlton E.
in Lieberman et al. 62
- Bretz, Harlan 30–1
- Brewer, Douglas J. 105, 440n17
- Bright, William 173n128
- Brinsley, John 641
- Brinton, Laurel J. 578, 634–5, 639, 643, 646n8
- Britain, David 117
- Broad, Charlie D. 39
- Broadbent, D. E. 675
- Brody, M. Jill L. 643
- Brongniart, Alexandre 149n44
- Bronn, Heinrich G. 149n44
- Bronstein, Arthur J. xiv
in Ohala et al. 134n6
- Brough, John xvii
- Browman, Catherine P. 615, 681
- Brown, Cecil H. 280
- Brown, Lesley 131n1
- Brown, Penelope 578
- Brown, Roger 171n125
- Brown, Vivian R. 732
- Brugman(n), Karl 36, 444
- Bruguière, Jean-Guillaume 149n44
- Bruneau, Charles 541, 545
- Brunot, Ferdinand 541, 545
- Bruyn, Adrienne 578, 629
- Bryson, Bill 131n1
- Buchan, John (Baron Tweedsmuir of Elsfield) 130
- Buck, Carl D. 444, 479, 541
- Buckland, William 27, 144–5n31
- Budin, Gerhard 471
- Buffon, Georges Louis Leclerc, comte de 136n9, 149n44
- Burgin, Steve xii
- Burguière, André 170n120
- Burkhardt, Richard W., Jr 136n9, 148–9n44
- Burnham, Tom 89
- Burridge, Kate 583
- Burzio, Luigi 227
- Busà, M. Grazia
in Ohala et al. 134n6, 677
- Bush, George Herbert W. 86, 89 (President [father])
- Bush, George Walker viii, 89 (President [son])

- Bush, Guy L. 157n73
 Buss, Leo W.
 in Cunningham et al. 160n83
 Butler, Samuel 136n10
 Butters, Ronald 162n88
 Buttler, Haro von
 in Altman et al. 512
 Bybee, Joan L. 79, 121, 125–6, 206, 208n3,
 241n14, 400n7, 413, 419, 459n15,
 459n19, 472, 572n2, 577–8, 580, 587–9,
 600n9, 600n17, 602–3, 605–7, 610, 615,
 617–19, 622n3, 622n5, 623n9, 624, 629,
 632–5, 644–6, 659, 738, 740
 see also Hooper, Joan Bybee
 Bynon, Theodora 40, 44, 61, 151n53
- Cable, Thomas 141n22
 Caesar, Gaius Julius 89
 Caesar Octavianus, Gaius Julius Augustus
 (Emperor) 88
 Cain, Arthur J. 158n74
 Calebresi, Renata 146n36
 Calk, Lewis C.
 in Chin et al. 18
 Callaghan, Catherine A. 116, 276
 Callary, Robert 725
 Calvin, William H. 116
 Cameron, H. Don 68
 Campbell, Lyle 41, 58, 77, 85, 94, 117–18,
 171n122, 177n142, 187, 204–6, 209n13,
 211n26, 264, 270–1, 273, 279, 295,
 304, 307t, 309–10, 310n6, 450–1, 486,
 489n15, 505, 524, 530, 537, 548, 549n1,
 553–4, 579, 581–4, 592–3, 599, 599n1,
 599n3, 600n6–8, 600n13–14, 601n21,
 601n24–5, 629–30, 646n7, 693
 Candide 69, 161n85
 Cannon, Walter F. 149n45
 Čapek, Milíč 39
 Carden, Guy 505
 Carlson, Gregory N. 151n51
 Carozzi, Albert V. 148–9n44
 Carpenter, Philip xii
 Carroll, John B.
 in Bever et al. 741
 Carroll, Lewis 442
 Carstairs-MacCarthy, Andrew 471n1, 116
 Carter, Richard T. 210n17, 210n20
 in Rankin et al. 191, 210n17
 Carver, Craig, M. 714
 Cassidy, Frederic G. 131–2n1
- Casti, John L. 508n2
 Cecil, Algernon 176–7n141
 Cedergren, Henrietta J. 373, 383, 385, 511
 Cerrón-Palomino, Rodolfo 270, 451
 Chadwick, John 142n25
 Chafe, Wallace 557, 570–1, 625
 Chambers, Jack K. 718, 722, 724, 726, 728–9
 Changeux, Jean-Pierre 138–9n17
 Charles, Elena 555, 558
 Charles, George 564–5
 Charles Ali, Elizabeth 555, 559–60, 572n3
 Charlesworth, Brian 157n71
 Charlton, William 150n49
 Chaucer, Geoffrey 86, 611–14, 622n4,
 623n9, 637
 Chaudron, Craig 77
 Chavée, Honoré 9
 Cheetham, Alan H. 50, 157n71
 Chen, Matthew Y. 115, 185, 314
 Cheng, Chin-Chuan 314, 459n24
 Cheshire, Jenny 733n5, 738
 Chesterton, Gilbert K. 23–4
 Chew, John J. 304
 Chin, Karen 18
 Ching, Marvin K. L. 117
 Cho, Young-mee Yu 175n135, 320, 333–5,
 341n18
 Chomsky, Avram Noam 5, 138n17, 152n60,
 242n21, 365n5, 404, 418–19, 431, 437,
 495, 500, 507, 508n1, 509, 685
 Christdas, Pratima 341n8
 Christian, Donna 168n115, 717
 Christy, T. Craig 29–30, 34–5, 149n45,
 734n8
 Chung, Sandra 243n31
 Cicero, Marcus Tullius 251, 260n16, 541
 Cid, el (= Rodrigo (Ruy) Díaz de Vivar)
 xvi, xviii5, 211n30
 Clari, Robert de 541
 Claridge, Michael F. 53
 Clark, D. Ross 243n31
 Clark, Maudemarie xii
 Clark, Robin 500–1, 507
 Clarke, Brian 178n148
 Clarke, Samuel 91
 Claudi, Ulrike 587, 595, 599, 632, 646n3
 in Heine et al. 81, 586–8, 591, 603, 624,
 632, 636, 638, 644–5, 646n3, 647n10
 Clausing, William xi
 Clay, E. Robert 146n36
 Cleland, Carol E. 151n49

- Clemens, Samuel L. *see* Twain, Mark
Clements, George N. 340n8
Cleveland, Grover (President) 164–5n100
Coates, Richard 431, 432–6
Coetsem, Frans van 384, 691
Cohen, Marcel 170–1n121
Cole, Jennifer S. 419
Coleman, John
 in Olive et al. 672
Coleman, William 34
Collier, Michael 23
Collinge, Neville E. 7, 36, 134n6, 172n127, 445
Collingwood, Robin George 8, 23, 107–8, 155n68, 165–6n104
Colman, Fran 510
Columbus, Christopher (Cristoforo Colombo; Cristóbal Colón) 183
Company, Concepción 633
Comrie, Bernard S. 133n3, 204, 413, 691, 693, 740
Condillac, Étienne Bonnot de Mably, abbé de 149n44, 575–6
Confucius (Kung Fu-tse, né Kung Chiu) 171n121
Constable, Nick 103
Conway, Robert S. 54
Cook, Eung-Do 705
Coppola, Marie
 in Kim et al. 743
Corbett, Greville 299
Corder, S. Pit 77
Cornaco, Rodolphus de 138n14
Coseriu, Eugenio 43–4, 47, 80, 152n60, 401, 662n11
Cottle, Basil 131n1
Courtenay, Michael J. 138n14
Cowan, William 134n6
Craig, Christopher
 in Wolfram et al. 717, 727, 732
Craig, Colette G. 590
Craig, William L. 97
Crampton, Henry E. 178–9n148
Cran, William
 in McCrum et al. 164n98
Crane, Tim 150n49
Cravens, Thomas 341n14
Crick, Bernard R.
 in Walker et al. 170n120
Croft, William 156n70, 161n85, 593, 625
Crowley, Terry 88, 117, 652
Cruttendon, Alan 639
Crystal, David 19, 168
Cukor-Avila, Patricia
 in Bailey et al. (1989) 17
Cunningham, C. W. 160n83
Curtius, Georg 106, 136–7n11
Cutler, Anne 742
Cuvier, Georges (baron) 8, 27, 34, 149n44

d’Ailly, Pierre 138n14
D’Introno, Francesco 616
Dahl, Ingolf 125
Dahl, Östen 578, 587, 602, 634
Daisley, Elaine
 in Guy et al. 117, 385, 388, 398
Dalberg-Acton, John E. E. (Baron Acton of Aldenham) 145n34
Dale, Philip S.
 in Bates et al. 174n133
Dale, Richard 129
Damian, Peter (Cardinal Bishop; St) 138n14
Danesi, Marcel 439n7
Daniels, Michael xii
Darden, Bill J. 677
Darwin, Charles R. 24, 27, 50, 52–4, 60, 64–5, 138–9n17, 157–8n74, 158n76, 161n85, 238, 341n15, 686n2
Dasher, Richard B. 634, 646, 666n34
Davies, Gordon L. 34, 149n45
Davis, Boyd H. 134n6
Dawah, Hassan A.
 in Claridge et al. 53
Dawkins, Richard 55, 57–9, 64–5, 81, 139n17, 156n70, 157n71, 159n77, 690
De Camp, David 460n28
De Chene, Brent 329, 360, 368n35
de la Calle, Antonio 9
Dean, James 163n97
Decker, Barbara B. 32
Decker, L. R. 675
Decker, Robert W. 32
DeGraff, Michel 119
Deiters, Hermann
 in Thayer et al. xiv, xviiiin4
DeLancey, Scott 226, 241n10, 243n32
Delbrück, Berthold 134–5n8
Delisle, Helga H. 273
Delogu, C.
 in Plauché et al. 686n4
Dench, Alan 239

- Dening, Greg(ory) M. 38, 119
 Denison, David 527n14
 Dennett, Daniel C. 157n71
 Derwing, Bruce L. 415
 Descartes, René (Renatus Cartesius) 149n44
 Desmarest, Nicolas 149n44
 Desmet, Piet 7–9, 135n8
 Desnitzkaja, Agnja V. 135n8
 Devitt, Dan 578
 Dickens, Charles 165n103–4
 Dickerson, Wayne B. 316
 Dickinson, Goldsworthy L. 151n50
 Dieninghoff, Joseph 542–4, 550n21, 551n24
 Diesing, Molly 510
 Diessel, Holger 578, 601n25
 Dietrich, Michael R. 53
 Diewald, Gabriele 577
 Disterheft, Dorothy 553
 Dixon, Robert M. W. 52, 73, 136n11, 174n131, 177n142
 Dobson, Austin 127
 Dobson, Eric J. 337–8, 342n25–6
 Dobzhansky, Theodosius G. viii, 52, 74, 138–9n17, 165n102
 Doe, Jane 100
 Doe, John 100
 Doerfer, Gerhard 275–6
 Dolgopolsky, Aharon B. 291
 Dolly (a cloned lamb > sheep) 156n70
 Dolomieu, Déodat de 149n44
 Donovan, Stephen K. 157n74
 Dorian, Nancy C. 705, 711n1, 711n4
 Dörner, Dietrich 430, 432
 Dorsey, James O. 210n22, 211n28
 Dow, Maureen
 in Derwing et al. 415
 Downes, William 416
 Doyle, Arthur C. (Sir) 130, 148n41
 Dresher, B. Elan 500
 Dressler, Wolfgang U. 10, 120, 124–5, 283, 409, 412, 435, 449, 457n2, 462–3, 465–71, 471n1, 621
 Dryer, Matthew 286
 Du Bois, John W. 634
 Du Marsais, César Chesneau 149n44
 Duby, Georges 170n120
 Dummett, Michael 138n14
 Dunkel, George 115–16, 147n37
 Duns Scotus, John 25
 Dupuis, Fernande 518
 Durand, Marguerite 686n5
 Duranti, Alessandro
 in Antinucci et al. 741
 Durie, Mark 459n23, 646
 Dyen, Isidore 173n129
 Eames, Charles 80
 Eames, Ray 80
 Earle, John 526
 Earman, John 91, 96–7, 99
 Ebeling, Carl L. 330, 413
 Ebert, Robert P. 542, 545, 578
 Eckert, Penelope 389, 738
 Eco, Umberto 148n41
 Eddington, Arthur S. 91
 Edison, Thomas A. 140n20
 Edkins, Joseph 672
 Edmondson, Jerold A. 528n17
 Edwards, Ann M. 97
 Edwards, Paul 89
 Ehala, Martin 176n140, 471, 662n11
 Ehrenfels, Christian von 429
 Ehring, Douglas 97
 Ehrlich, Robert 99
 Einstein, Albert 95, 98, 100
 Elcock, W. D. 18
 Eldredge, Niles 50–3, 55, 57–9, 61–2, 64, 78, 139n17, 158n74, 159–60n81
 in Lieberman et al. 62
 Eliasson, Stig 695–6
 Elizabeth I (queen of England) 102
 Ellegård, Alvar 501–2, 513–14
 Ellis, George F. R. 98
 Elman, Jeffrey L. 743
 Embleton, Sheila 134n6, 173n129, 431, 434
 Emeneau, Murray B. 693
 Emerson, Ralph Waldo 131, 180n150
 Emonds, Joseph 498
 Endler, John 53
 Engelmann, G. F. 55, 139n17
 Engler, Rudolf 175–6n138
 Enkvist, Nils Erik 647n16
 Epicurus 91
 Epstein, Samuel D. 366n20
 Ereshefsky, Marc 53, 71
 Erickson, Gregory M. 18
 in Chin et al. 18
 Erman, Britt 642
 Ernst, Thomas B. 639, 643
 Erwin, Douglas H. 160n83
 Esper, Erwin A. 434, 439n3, 440n17

- Essen, Otto von 686n5
Everett, Hugh, III 98
Ewan, William G.
 in Hombert et al. 173n128, 670, 672
- Faarlund, Jan Terje 508n3
Fabb, Nigel 491n28
Fagan, Brian 17
Fant, Gunnar
 in Jakobson et al. 341n17
Fasold, Ralph W. 716
Feder, D. 672
Felber, Helmut 471
Fenyvesi, Anna 705
Ferguson, Charles A. 77, 321
Fernández-Armesto, Felipe 56
Ferrara, Kathleen 639, 641
Ferrucci, Fabrizio 12
Fertig, David 409, 412
Feynman, Richard P. 98
Fidelholtz, James L. 615
Field, Fredric W. 308–9
Fields, William C. (né Dukenfield) 89
Fierro, Martín xiii
Fikkert, Johanna P. M. 500
Fillmore, Charles J. 77, 174n133, 625, 646
Fischer, David Hackett xiv, 150n48,
 177n143
Fischer, Olga C. M. 122, 531, 740
Fisher, John 715
Fleischman, Suzanne 578, 635
Fleming, Harold C. 278
Flew, Antony G. N. 97
Fliegelman, Jay 172n126
Flood, Raymond 90
Foch, Ferdinand (Field Marshal) 129,
 177n144
Fodor, Istvan 65, 68
Fodor, Jerry A. 438, 500
Foley, James 335
Foley, William A. 646n7, 696
Folger, Tim 167n110
Fölsing, Albrecht 95
Fontaine, C. 514
Fontana, Josep M. 503, 518
Fontenelle, Bernard Le Bovier, sieur de
 149n44
Ford, Henry 3, 132n1
Fortson, Benjamin W., IV 41–2, 79, 116,
 122–3, 125–6, 206, 208n3, 214n14,
 459n19, 472, 665n26, 665n29
- Foster, Michael K. 134n6
Fought, John G. 134n6
Fowler, Carol A. 616
Fowler, Harold N. 10
Fowler, Joy 397
Fox (*alopex*) 639
Fox, Anthony 117, 189, 209n10, 209n12,
 245, 259n1
Fox, Danny
 in Barbosa et al. 141n21
Fox, Richard G. 177n143
Frajzyngier, Zygmunt 578, 582
Francis, W. Nelson 604, 666n37
Fraser, Bruce 639, 642
Fraser, Julius T. 90
Freeman, Scott 160n83
Friedrich, Paul 171–2n125
Friedrich, W. 459n18
Fries, Charles C. 505
Frigga 137n12
Fritz, Gerd
 in Jucker et al. 171n125
Frolov, Valery P. 98
Fromkin, Victoria 440n16, 737
Füchsel, Georg C. 149n44
Fujimura, Osamu 671
Fuller, Reginald 137n12
Futuyma, Douglas J. 61, 160n83
- Gaaf, Willem van der 550n14
Gabelentz, Georg von der 576, 631
Gaeta, Livio 473
Gale, Richard M. 90, 138n14
Galen(us), Claudius 669
Galilei, Galileo 34, 149n44, 399
Gamkrelidze (Gamqreli(d)ze), T'amaz V.
 115–16, 133–4n5, 147n37, 174n132
Garrett, Andrew 147n37, 313n1, 340n1,
 662n6, 681
Gass, Susan M. 77
Gates, Phelps 247
Gauchat, Louis 17, 369, 452
Geach, Peter T. 150–1n49, 150n50
Geary, Dana H. 160n83
Gebert, Lucyna
 in Antinucci et al. 714
Geeraerts, Dirk 665n22
Geertz, Clifford 178n147
Geis, Michael L. 634
Geneti, Carol 578
Gensler, Orin D. 305, 307

- George VI (king of England) 130
 George, John 89
 Gess, Randall 175n135
 Ghent, Henry of 25
 Ghiselin, Michael T. 53
 Gibbon, Edward 180n151
 Gibson, Edward 500
 Gibson, Helen 103–4
 Giddings, Luther V. 53
 Gilbert, Albert 171n125
 Gili Gaya, S. 682
 Gili, Filippo S. 268, 272
 Gilliéron, Jules 115
 Gilligan, Gary 742
 Gimbutas, Marija 174n132
 Gingerich, Philip D. 157n71
 Ginneken, Jacques van 135n9
 Girard, Dennis 723
 Girard de Rialle, Julien 9
 Givón, Talmy 204, 226–7, 488n4,
 524, 576, 578, 593, 625, 627, 630,
 740
 Glassie, Henry 37, 130
 Gleitman, Henry
 in Newport et al. 502
 Gleitman, Lila R. 174n133
 in Newport et al. 502
 Goddard, Ives 141n22, 208, 261n26, 266,
 270, 739
 Gödel, Kurt 98–100
 Goldberg, Adele 625
 Goldin-Meadow, Susan 504
 Goldsmith, John A. 313n
 Goldstein, Louis M. 615, 681
 in Beddor et al. 675, 677
 Golla, Victor 269
 Golovko, Evgenij V. 707
 Gonsalves, Anthony xii
 Goodenough, Ward 160n81
 Goodfriend, Glenn A. 59
 Goodheart, Adam 103
 Goodman, Morris 276–7
 Goodman, Nelson 149n45
 Goolden, Peter 526
 Goosens, Louis 607t, 607–8
 Gopal, H. S. 672
 Gordon, Arthur E. 14
 Gordon, Elizabeth 371
 Gordon, Matthew 295, 298
 Gorman, James 150n47
 Gott, J. Richard 98–9
 Gould, Stephen Jay 26–8, 30–5, 37, 50–3,
 55, 57–61, 65, 73, 136n9, 139n17,
 144–5n31, 162n91, 178–9n148,
 179–80n81
 Goyvaerts, Didier L. 135n8, 661n1
 Grace, George W. 231–2, 243n36
 Graczyk, Randolph (fr.) 210n22, 211n24,
 211n28
 Grafton, Anthony 133n4, 180n151
 Grammont, Maurice 192
 Grant, B. Rosemary 60
 Grant, Michael 18, 164n100
 Grant, Peter R. 60
 Gräslund, Bo 153–4n64–5
 Graßman, Hermann 331, 678, 680
 Green, John N. 18
 Green, R. 243n35
 Greenberg, Joseph H. 22, 58, 217, 224,
 242n24, 264–7, 270–2, 275–8, 280–1,
 286, 300, 372, 578
 Greenberg, Steve 686
 Greene, Brian 95, 101, 167n109
 Greenwood, A.
 in Olive et al. 672
 Grégoire, Antoine 274
 Gregory, Elizabeth 721
 Greither, Aloys 165n100
 Grimm, Jacob 134n6, 267, 315, 398, 457n6,
 631
 Grimsdóttir, Guðrun
 in Kristjánsdóttir et al. 527n10
 Grosjean, François 698
 Grosseteste, Robert (bishop of Lincoln) 24
 Guarducci, Margherita 14
 Gudschinsky, Sarah 173n129
 Guion, S.
 in Lindblom et al. 683
 Güldemann, Tom 578
 Gumperz, John J. 690, 695
 Guthrie, Malcolm 672
 Guy, Gregory R. 10, 13, 41, 62, 115, 117,
 120–3, 159n78, 175n135, 208n5, 374,
 376, 379–85, 388, 393–4, 398, 403, 462,
 511, 526n3, 527n6, 715, 738
 Guy, Jacques 230
 Haas, Mary R. 93–4, 270
 Haeberli, Eric 511
 Haegeman, Liliane 528n17
 Haeri, Niloofar 383, 390
 Haft, Adele J. 148n41

- Hagège, Claude 634
Hägerstrand, Torsten 725
Haggett, Peter 726
Hagstrom, Paul
 in Barbosa et al. 141n21
Haiman, John 241n9, 409, 412, 603, 622,
 646n7
Haines, Tim 103–4
Haldane, John B. S. 50
Hale, Mark 14, 21, 41–2, 115, 120–3, 126,
 173n128, 208n5, 349, 364n4, 365n10,
 367n26, 368n37, 400n7–8, 436, 459n22,
 476, 541, 631, 662n6
Haley, Michael C. 431, 432–3, 439n7
Halldórsson, Bragi 527n10
 in Kristjánssdóttir et al. 527n10
Halle, Morris 74–5, 404, 418–19, 653, 685,
 737
 in Jakobson et al. 341n17
Halliday, Michael A. K. 600n18
Halliday, Wilfrid J. 63
Hamish, G. Spencer 53
Hammerstein, Oscar, II 178n148
Hamp, Eric P. 99, 210n16
Handel (né Händel), George Frideric xiv
Hankamer, Jorge 738
Hanley, Miles L.
 in Kurath et al. xv, 725
Hansen, Marcus L.
 in Kurath et al. xv, 725
Hanson, K. 639
Har(r)ington, John (Sir) 106–7
Harms, Robert T. 452
Harper, David A. T. 160n83
Harris, Alice 77, 120–2, 177n142, 204–6,
 211n26, 486, 505, 530, 536–7, 548,
 549n1, 550n12–13, 550n19, 553–4,
 579, 582, 593, 599, 600n7–8, 601n21,
 600n24–5, 629–30, 646n7
Harris, Roy 4, 398
Harrison, Geoffrey A. 70
Harrison, Sheldon P. 21, 79, 83, 116–18,
 125–6, 159n79, 204, 227–8, 234–6,
 472
Harv 115
Harvey, Paul H. 68
Hashimoto, Mantaroo J. 452
Haspelmath, Martin 58, 578, 580, 582,
 592–3, 619
Hasselmo, Nils 695
Haugen, Einar I. 157n70
Haukioja, Jussi 425, 426, 427, 428, 431, 432,
 437–8, 439n2, 440n16
Haury, Emil 18
Hauser, Marc D. 116
Hawking, Stephen W. 98–9
Hawkins, John A. 148n40, 525, 742–3
Hazen, Kirk
 in Wolfram et al. 717, 727, 732
Headrick, M. P. 98
Healey, Richard A. 90
Heaney, Seamus 164n99
Heath, Jeffrey 298, 693, 696
Hecht, Hans 526
Hegel, Georg W. F. 135n8
Heine, Bernd 13, 79, 81, 121, 125–6,
 152n63, 206, 208n3, 241n14, 304, 430,
 449, 459n19, 461, 472, 490n23, 492n38,
 505, 572n2, 577–9, 586–9, 591, 593–4,
 597–9, 602, 618, 624–5, 631–2, 636, 638,
 644–6, 646n3, 647n10, 665n23, 740
Hellman, Lillian
 in Bernstein et al. 70
Helman, David H. 440n8
Hendrickson, Robert L. 131n1
Hennig, Willi 157–8n74
Henry, Reginald 568
Henton, Caroline G.
 in Bladon et al. 673
Heraclitus 10, 42
Herbert, Robert K. 297
Herder, Johann Gottfried 7, 553
Hermann, M. Eduard 369, 428, 435, 439n3,
 444, 451–2
Hernández, José xiii, xviii2
Herod the Great 137n12
Herring, Susan C. 629, 646n9
Herron, Jon C. 160n83
Herzog, Eugen 74
Herzog, Marvin I.
 in Weinreich et al. 77–8, 119–20, 123,
 214, 369, 371, 373, 401, 512, 654, 662n9,
 684, 714, 716, 720, 733n2
Hesse, Mary B. 425
Hesychius 15, 142n24
Hewitt, J. N. B. 569
Hibiya, Junko 371, 383–5
Hildebrand, Hans 153n64
Hill, Archibald A. 453
Hillman, Gordon C. 17
Himmelman, Nikolaus 578
Hinskens, Frans 175n135

- Hirschbühler, Paul 515
 Hirt, Hermann 106, 115
 Hitler, Adolf xviii3
 Hock, Hans Henrich 22, 79, 120, 124–7,
 134n6, 136n11, 147n37, 168–9n116,
 173n128, 177n142, 206, 208n3, 241n14,
 267, 283, 331, 400n8, 434, 441, 436,
 444–54, 457n2–3, 458n10, 459n13–14,
 459n16, 459n18, 460n27–8, 472, 490n19,
 492n40, 621, 652, 660, 661n1, 677, 721,
 723
 Hockett, Charles 91–2, 102, 111–12, 140n18,
 140n20, 143n28, 145n32, 165n103,
 166n105
 Hodge, Carleton T. 141n22, 599n4
 Hoehner, Harold W. 137n12
 Hoekstra, Rolf F. 160n83
 Hoenigswald, Henry M. 151n52, 152n61,
 192, 209n7–8, 244–5, 253, 343, 411, 454,
 488n5, 661n4
 Hofbauer, Gottfried
 in Naumann et al. 34
 Hoff, Karl von 149n44
 Höfding, Harald 430, 432
 Hoffman, Antoni 157n71
 Hogg, Richard M. 178n146
 Holford-Strevens, Leofranc 137n12
 Hollander, M.
 in Kim et al. 743
 Hollindale, R. J. xii
 Holman, Eugene 406, 422n7
 Holmes, Janet 371
 Holmes, Sherlock 130, 148n41
 Holt, Alfred H. 131n1
 Holt, D. Eric 175n135
 Holyoak, Keith J. 428, 430, 432, 433, 434,
 438, 439n2, 440n9
 Hombert, Jean-Marie 173n128, 670, 672
 Homer 517
 Hooper, Joan Bybee 409, 412–13, 472–3,
 484, 615, 621
see also Bybee, Joan L.
 Hooykaas, Reijer 30, 149n45
 Hopkins, G. W. 45
 Hopper, Paul J. 115–16, 121, 147n37,
 175n136, 208n3, 365n5, 449–50, 477–8,
 484, 488, 488n4–5, 490n18, 490n21,
 490n23, 491n24, 492n36, 492n40, 505,
 565, 577–8, 580, 588–9, 592–3, 600n6,
 601n22, 607, 615, 624–5, 629–31, 634,
 636, 740
 Horn, L. R. 634
 Horner, John R. 150n47
 Hornstein, Norbert 498
 Horvath, Barbara
 in Guy et al. 117, 385, 388, 398
 Horwich, Paul 91, 97
 Houk, Rose 23
 Housum, Jonathan 616
 Hout, Roeland van
 in Hinskens et al. 175n135
 Hovelacque, Abel 9
 Howard, Daniel J. 53
 Hróarsdóttir, D. 525
 Hrozny, Bedřich (/Friedrich) 168–9n116
 Hualde, José Ignacio 619
 Hubbert, Marion K. 149n45
 Hubel, D. 138–9n17, 500
 Huber, Magnus 578
 Hudson, Kenneth 145n32
 Huggett, Richard 148n42
 Hughes, Geoffrey 661n6
 Hulk, A. 527n14
 Hull, David L. 53, 73, 156n70
 Humboldt, Wilhelm von 74, 445–6,
 576
 Hume, David 35, 149n44, 180n151
 Hünemeyer, Friederike
 in Heine et al. 81, 586–8, 591, 603, 624,
 632, 636, 638, 644–5, 647n10
 Hunter, R. S. T. 68
 Hura, S.
 in Lindblom et al. 683
 Hurch, Bernhard xviiiin5
 Hurford, James R. 116
 Hurtig, Richard R.
 in Bever et al. 741
 Hutcheson, Francis 641
 Hutcheson, James 334
 Hutton, James 34–5
 Huxley, Thomas H. 105, 158n76
 Hyams, Nina 500
 Hyman, Larry M. 409, 412, 677
 Hymes, Dell H. 134n6, 173n129
 Ibn Hazm of Cordoba 554
 Ibn Khaldūn 553
 Illich-Svitych, Vladislav M. 271–2, 278
 Inge, M. Thomas 148n41
 Ingólfssdóttir, G.
 in Kristjánsdóttir et al. 527n10
 Inkelas, Sharon 320, 367n23

- Inwagen, Peter van 90
Isačenko, Alexander V. 597
Isaiah, (Deutero-) 114
Itkonen, Esa 425–8, 430–2, 437–8, 439n2, 439n5, 440n9, 440n14–15
Ivanov, Vyacheslav I. 115–16, 133–4n5, 147n37, 174n133
- Jaberg, Karl xiv–xv, 115
Jablonski, Nina G. 116
Jackendoff, Ray S. 437, 639, 643
Jackson, Frederick H. 237
Jackson, Jeremy B. C. 50, 157n71
Jacob, François 138–9n17
Jacobi, W. A. T. 670
Jacobs, Andreas 171n125
Jacobs, Melville 693
Jacobs, Neil G.
 in Janda et al. 66, 156–7n70, 177–8n145, 179n149
Jacobsen, William H., Jr 291, 304
Jacobson, Steven 561
Jaeger, Jeri J. 415
Jakobson, Roman O. 21, 61, 136–7n11, 146–7n36, 273–4, 294–5, 315, 317, 327–8, 340, 341n17, 359–60, 412, 461, 677
James I (king of England) 102, 114
James, William 146n36
Jameson, David L. 53
Janda, Laura A. 457n2, 469
Janda, Richard D. 5–6, 10, 19, 34, 36, 44, 48, 56, 58, 63, 66, 75–6, 78, 85, 93, 120–2, 124, 126, 132n1, 145n34, 152–3n63, 156–7n70, 162n90, 171n122, 173n128, 175n135, 175n137, 177n142–3, 177–8n145, 179n149, 208n5, 209n12, 241n14, 345, 349, 355, 367n28, 403, 405–8, 412, 416–17, 420, 421n2, 421n4, 422n8, 422n10, 450, 465, 473–5, 478, 485, 488n1, 489n15, 490n17, 492n36, 492n38, 492n40, 526, 581–3, 585, 599, 599n1, 599n5, 599n11, 629, 646, 661, 663n15, 665n27, 666n33, 734n8
Janson, Tore 453
Janus 137n12
Jasanoff, Jay 174n132
Jeffers, Robert J. 106, 444, 629, 652, 661n1
Jefferson, Thomas 172n126
Jern, N. 138–9n17
Jespersen, J. Otto H. 135n8, 163n96, 261n23–4, 463, 662n12, 669
Jesus of Nazareth 137n12
Job xii
Job, Michael 147n37
Johanson, Lars 156n70, 308–9
Johnson, Michael 178n148
Johnson, Sarah E. Jackson 54
Johnson, Theodore C. 615
Jolson, Al 140n20
Jonas, D. 510
Jonasson, J. 686n5
Jones, A. Wesley 210n20
 in Carter et al. 210n17
 in Rankin et al. 191, 210n17
Jones, Charles 177n142, 497, 717, 733n5, 734n7
Jones, John P. (Captain) 128–9
Jones, William (Sir) 208n1
Jongen, René 459n18
Joos, Martin 134n6, 409–10, 715
Joseph, Brian D. 5, 10, 56, 66, 79, 94, 120–2, 125–6, 132n1, 133n3, 134n6, 136n11, 138n16, 145n33, 147n37, 153n63, 162n89, 171n122, 175n137, 177n142, 177–8n145, 179n149, 206, 208n3, 209n12, 241n14, 242–3n28–9, 243n38, 403, 405–8, 419–20, 421n2, 422n6, 422n10, 439n6, 441, 446, 449–50, 459n19, 460n28, 466, 469, 473–5, 481–2, 484–5, 488n2, 488n7, 489n10, 489n15, 491n30, 491n34, 492n35, 492n36, 492n40, 526, 581–2, 584–5, 599, 600n12, 600n14, 629, 652, 659, 660–1, 661n1, 665n29, 666n33, 693, 705, 738, 740, 742
 in Janda et al. 66, 156–7n70, 177–8n145, 179n149
Joseph, John E. 134n6
Jucker, Andreas H. 171n125
Jud, Jakob xiv–xv
Judas (the disciple) 637
Julius *see* Caesar, Gaius Julius
Juno (Hera) 137n12
Jupiter (Jove; Zeus) 137n12
Jurafsky, Daniel 415, 658
- Kaila, Eino 429
Kaiser, Mark 271–2
Kaisse, Ellen M. 643
Kaku, Michio 91, 99, 156n70

- Kaneshiro, Kenneth Y.
in Giddings et al. 53
- Kant, Immanuel 91, 137n11
- Kaplan, Tami xii
- Karlsson, Keith 488n5
- Karr, Alphonse 10
- Kastovsky, Dieter 19–20
- Kathman, David 6, 132n1
- Kauffman, S. 138–9n17
- Kaufman, Terence 72, 183, 229, 241n13,
290, 690–2, 700, 703, 707
in Campbell et al. 304, 309–10, 693
- Kawasaki-Fukumori, Haruko 682,
686
- Kay, Paul 171n123, 625, 664n17, 664n20
- Kaye, Jonathan D. 500
- Keel, William 420–1
- Keenan, Edward L. 740
- Keller, Rudi 427, 439n7, 461
- Kellogg, D. E. 157n71
- Kemenade, Ans van 503, 505, 510, 519,
527n14
- Kemmer, Suzanne E. 578, 611
- Kempe, Margery 640
- Kempelen, W. von 670
- Kempler, Daniel
in Fillmore et al. 77, 174n133
- Kennedy, A. G. 611
- Kennedy, John F. (President) 131
- Kerns, John C. 272
- Kerswill, Paul 174n133, 738
- Key, T. H. 670
- Keyser, Samuel J. 506
- Kibrik, A. E. 293t, 302t, 549, 550n18
- Kilani-Schoch, Marianne 471n1
- Kilian-Hatz, Christa 577
- Kim, Hyeree 484
- Kim, J. J. 743
- Kim, Sung-Won 98
- Kimball, Geoffrey 280–1
- Kimbel, William H. 53
- King, M. C. 67
- King, Robert D. 75–6, 447, 683, 738
- Kinkade, M. Dale 693
- Kiparsky, R. Paul V. 74–5, 106, 115, 120,
126, 171n123, 173n128, 208n5, 313,
315–16, 319–22, 325, 330, 337, 340n5,
340n7, 341n13, 346, 350–7, 359–62,
367n24–5, 367n27, 368n34–5, 374,
392, 400n9, 403–4, 406, 412–13,
422n9–10, 437, 447–8, 451, 453, 458n7,
459n25, 466, 506, 525, 631, 683, 717,
737
- Kiparsky, Valentin 409–12, 422n9
- Kirchner, Robert M. 175n135
- Kitts, D. B. 149n45
- Klatt, D. H. 673
- Klausenburger, Jürgen 464, 489n14
- Klein, Jared S. 20
- Klejn, Leo S. 153n64
- Klima, Edward S. 74–6
- Klindt-Jensen, Ole 153n64
- Kloeke, Giesinus C. 725
- Kluge, Friedrich 259n6
- Knight, Chris 116
- Knodel, Arthur 125
- Koch, Harold 198
- Kodzasov, S. V. 293t
- Koerner, E. F. Konrad 7, 134n6, 135n8,
165n106, 175–6n138, 444, 458n10
in Aurox et al. 134n6
- Kolb, Eduard 63
- König, Ekkehard 578, 587, 633–4
- Koontz, John 210n20, 210n22, 210n28
- Koopman, W. F. 510
- Korhonen, Mikko 329–30, 409, 411–12
- Koselleck, Reinhart 178n146
- Koster, J. 527n12
- Kotsinas, Ulla-Britt 642
- Krakow, Rena Arens
in Beddor et al. 675–7
- Krauss, Michael E. 269
- Krishnamurti, Bhadriraju 453
- Kristjánsdóttir, B. 527n10
- Kroch, Anthony S. 77, 140–1n21, 159n78,
332, 387–8, 394–7, 496–7, 501–2, 505,
510–11, 512–15, 514f, 518, 524, 525–6,
526n2, 527n14, 531, 549n4, 715, 740
- Kroeber, Alfred Louis 20, 140n18, 269
- Kruszewski, Mikołaj Habdank- 341n15
- Krynine, Paul 149n45
- Kučera, Henry 604, 666n37
- Kulick, Don 704
- Kuno, Susumu 741
- Kurath, Hans xv, 725
- Kurt 97
- Kuryłowicz, Jerzy 168–9n116, 434–5,
444–7, 459n13, 472, 475, 576, 581,
625
- Kuteva, Tania 578, 590–1, 594
- Kyes, Robert 141n22
- Kytö, Merja 646

- Labelle, Marie 515
- Labov, William D. 13–14, 17, 22, 25, 28–31, 41, 44, 49, 51, 71–3, 77–8, 84, 87–8, 115, 119–20, 123, 129, 141n21, 144n29, 145–6n35, 152n60, 159n81, 161n85, 161n87, 177n142, 178n146, 209n7–8, 209n12, 214, 241n16, 298, 313n1, 321, 323, 325–6, 335, 340n1, 341n10–11, 351, 365n5, 369–71, 373, 376, 378, 384–90, 392, 394, 397, 399n1, 400n9, 403, 410, 416, 419–21, 452–3, 455, 459n13, 459n23, 460n26, 615, 714, 717–20, 722–3, 727, 729, 733n2, 733n7, 733n10, 736, 738, 740
- in Weinreich et al. 77–8, 119–20, 123, 214, 369, 401, 512, 654, 662n9, 684, 714, 716, 720
- Ladefoged, Peter N. 22, 334, 675, 680, 682
- Laforest, Marty
- in Vincent et al. 643
- Lakoff, George 415
- Lamarck, Jean-Baptiste (chevalier) 65, 136n9, 149n44
- Lambert, David M. 53
- Lambrecht, Knud 631
- Lamy, Bernard 553
- Landau, Barbara 174n133
- Lande, Russell 157n71
- in Charlesworth et al. 157n71
- Langacker, Ronald W. 549n6, 610, 625, 627, 634, 646n9
- Langdon, Margaret 451
- Lange, Deborah 646n8
- Langendoen, D. Terence 741, 743
- Larmouth, Donald 723
- Lasnik, Howard 509
- Lass, Roger 9–10, 19–20, 33, 52, 73, 80, 121, 128, 156n70, 165n103–4, 175n137, 179n149, 197, 199, 209n7, 209n12, 210n15, 445–6, 459n21, 583, 646, 739
- Latkiewicz, G.
- in James et al. 117
- Latouche, John
- in Bernstein et al. 70
- Laudan, Rachel 149n45
- Lausberg, Heinrich 420, 488n5
- Lawrence, Nathaniel M. 90
- Lawton, John H. 52
- Le Grand, H. E. 149n45
- Le Poidevin, Robin 90–1, 138n14
- Lebsanft, Franz
- in Jucker et al. 171n125
- Lee, Gregory 334
- Leed, Richard L. 437
- Leek, Frederike C. van der 531
- Lefèvre, André 9
- Lehiste, Ilse 106, 444, 652, 661n1
- Lehmann, Christian 447, 475, 490n20, 490n23, 577–8, 588, 593, 605, 624–5, 627–8t, 629–31, 636, 638, 642, 646n3, 646n6, 647n12
- Lehmann, Winfred P. 22, 106, 115–17, 204–5, 211n25, 444, 447, 475, 588
- Lehrer, Adrienne 665n22
- Lehti-Eklund, H. 643
- Leibniz, Gottfried W. von (Freiherr) 25, 91, 149n44
- Leiter, Brian xii
- Leland, Charles G. 131n1
- Lemle, Miriam 396, 531
- Lenneberg, E. H. 737
- Lenski, Richard 59
- Leo XIII (Pope)
- Leopold, Werner 459n14
- Leskien, August 443
- Leslau, W. 615
- Levine, Amy-Jill 137n12
- Levinson, Steven C. 634
- Levinton, Jeffrey S. 157n71
- Lewis, David K. 97
- Lewis, Henry 405
- Lewis, Julie A.
- in Ohala et al. 134n6
- Lewontin, Richard 138–9n17
- Li, Fang-kuei 577, 626, 672
- Li, Li-Xin 98
- Lieberman, Anatoly 409, 411–12, 743
- Liddell Hart, Basil H. (Sir) 177n144
- Lieber, Rochelle 5–6, 15, 405
- Lieberman, Bruce S. 62
- Lien, Chinfa 452
- Lighter, Jonathan E. 131–2n1
- Lightfoot, David W. 6, 13–15, 41–2, 59, 74, 77, 80, 120–2, 125, 139n17, 141–2n23, 156n70, 159n81, 176n140, 177n142, 179n149, 206, 240n4, 496–501, 504–6, 508n1, 510–11, 526n1, 530, 537, 626, 629, 738, 740
- Lightner, Theodore 489n10
- Lincoln, Abraham (President) 3, 131
- Lindblom, Björn 671, 683

- Lindeman, Fredrik O. 133–4n5
 Linné, Carl von (Linnaeus) 53, 153n64,
 158n76
 Lloyd, Paul M. 166n104, 420
 Locke, Corinne A. 12
 Locke, John 149n44, 637
 Lockwood, Michael 90
 Löfqvist, Anders 173n128, 670
 Löfstedt, Bengt 597
 Lord, Carol Diane 578, 636
 Losos, Jonathan B. 60
 Lowenthal, David 169n119
 Lowman, Guy S., Jr
 in Kurath et al. xv, 725
 Lucretius Carus, Titus 11, 91
 Lund, Niels 164n99
 Luschützky, Hans-Christian 471n1
 Lyautey, Louis-Hubert-Gonsalve 131
 Lyell, Charles (Sir) 27–31, 33–6, 149n44
 Lyons, John 622
- Mabbott, J. D. 146n36
 Macaulay, David 105
 Macbeath, Murray 90, 97, 138n14
 Machiavelli, Niccolò 170n120
 Mackie, Penelope J. 88
 MacLagan, Margaret 371
 MacNeil, Robert
 in McCrum et al. 164n98
 MacWhinney, Brian 741
 Madden, Carolyn G. 77
 Maddieson, Ian 22, 297, 682
 Madvig, Johan Nicolai 148n43
 Maguran, Anne E. 53
 Mahut, C.
 in James et al. 117
 Maia 137n12
 Malkiel, Yakov xv, 40, 86, 115, 407, 451,
 464
 Mallory, J. P. 174n132
 Malone, Joseph L. 435
 Manaster Ramer, Alexis 229, 243n34, 331
 Mańczak, Witold 434, 435, 444, 445–6
 Manly, J. 77–8
 Mann, Virginia A. 675
 Mantell, Gideon (Dr) 104
 Mantell, Mary Ann 104
 Marks, Jonathan 69
 Markus, G. F.
 in Kim et al. 743
 Marle, Jaap van 465
- Mars (Ares) 137n12
 Martin, Lawrence B. 53
 Martinet, André 38, 683
 Mascaró, Joan 407
 Masica, Colin P. 304
 Maslova, Elena 309
 Maspero, Henri 672
 Mathangwane, J. 673t, 673
 Mathias (the disciple) 637
 Matisoff, James 282n6, 297
 Matsuda, M. 342n21
 Matsumoto, Y. 629
 Matthews, G. Hubert 74–5
 Matthews, Peter H. 134n6, 457n4
 Matthews, Sandra A.
 in Sussman et al. 671
 Maudlin, T. 97
 Maupertuis, Pierre(-)Louis Moreau de
 149n44
 Maurer, Armand A. 25, 148n41
 Maurer, Friedrich 551n22
 Maxson, Linda R.
 in Wilson et al. (1974) 67
 May, Robert M. 52–3
 Mayerthaler, Willi 435, 440n17, 462–3, 470,
 471n1–2, 471n5
 in Dressler et al. (1987) 462, 469, 471n1
 Maynard Smith, John 138–9n17, 157n71
 Maynor, Natalie
 in Bailey et al. (1989) 17, 738
 Mayr, Ernst 34, 36, 52–5, 71–4, 148–9n44,
 149n45, 157n73, 158n75
 McCaffrey, Helen A.
 in Sussman et al. 671
 McCain, John (Senator) viii
 McCrum, Robert 164n98
 McGarr, Nancy S.
 in Löfqvist et al. 173n128, 670
 McGinnis, Martha
 in Barbosa et al. 141n21
 Mchombo, Sam A. 491n26
 McIntosh, Roderick J. 153n64
 McLeish, Kenneth 150n48
 McLemore, Cynthia 117
 McMahan, April M. S. 135n8, 138n16,
 161n85, 175n135, 178n146, 444, 447,
 449, 472–3, 489n16, 655, 728
 in Renfrew et al. 166n107
 McTaggart, John M. Ellis 38–9, 151n50
 McWhorter, John 119
 Meier, Rudolf 53, 158n75

- Meiland, Jack W. 97
Meillet, P. Antoine 74–5, 170–1n121, 191,
207–8, 228–9, 263, 267–70, 274, 276–7,
279, 281–2n3, 292, 449, 473, 483, 545,
554, 576, 597, 601n22, 605, 624–5, 630
Meinecke, J. H. F. 143n28
Melchert, H. Craig 451
Mellis, E. 432
Mellor, D. Hugh 39, 90–1, 138n14, 146n36
Melville, Herman 641
Méndez Dosuna, Julián 465, 468, 491n33
Mendoza-Denton, Norma Catalina 646
Menéndez Pidal, Ramón xv–xvi, 682
Menn, Lise 741
Mercury (Hermes) 137n12
Merlini Barbaresi, Lavinia 462, 469
Mersenne, Marin 149n44
Meyer, E. A. 670, 672
Michel, H. V.
 in Alvarez et al. 31
Milius, Susan 12
Miller, James D. 672
Miller, Sarah Bryan 105
Miller, Thomas 526
Milroy, James 9, 13, 62–4, 78–9, 123, 728–9
Milroy, Lesley 13, 62–4, 123, 728–9
Minkova, Donka 63
Minkowski, Hermann 95, 98
Miranda, Rocky V. 444
Mirk, John (Johannes Mirkus) 640
Mish, Frederick C. 162–3n95
Mitchell, B. 527n14
Mithun, Marianne 6, 65–6, 68, 79, 120–1,
125–6, 206, 208n3, 241n14, 281, 459n19,
461, 472, 553, 565, 567–8
Moby(-)Dick (storied whale) 641
Mohan, Karuvannur P. 340n5, 341n8
Mommensen, Hans 139–40n18
Monod, Jacques 138–9n17
Montelius, Oscar 45–8, 153–5n64–7
Moon, Seung-Jae
 in Lindblom et al. 671, 683
Moonwomon, Birch 615
Moravcsik, Edith A. 468, 691
Morin, Yves-Charles 341n16
Morison, S. 119
Morpurgo Davies, Anna 6–7
Morris, Mary 131n1
Morris, Michael 98
Morris, William 131n1
Mossé, Fernand 620
Moulton, William G. 414–15, 454
Mous, Maarten 703, 708
Mouse, Mickey 26
Mowrey, Richard 79, 81, 615
Mozart, Wolfgang A. 165n100
Mufwene, Salikoko S. 9, 70–2, 578
Mühlhäusler, Peter 470
Müller, M. 680
Mundle, C. W. 89–90
Munro, Hector H. (“Saki”) 33
Murdock, George P. 273
Murphy, Bruce 164n100
Murray, James 178n148
Murray, Michelle 646
Muysken, Pieter 707
Myers, Scott 322
Myers-Scotton, Carol 695
Mylander, Carolyn 504
Nagy, Naomi 175n135, 743
Nahin, Paul J. 90, 99–100
Naro, Anthony J. 144n29, 396, 531
Naumann, Bernd 34
Navarro Tomás, Tomás 682
Nearey, Terrance
 in Derwing et al. 415
Need, Barbara 621
Nelson, W. S.
 in Avise et al. 160–1n83
Nepos, Julius (Emperor) 164–5n100
Nerlich, Brigitte 68, 648
Nevis, Joel A. 450, 485
Newell, Norman D. 149n45
Newman, Ezra T. 98
Newman, Paul 301
Newmeyer, Frederick J. 134n6, 171n122,
177n142, 241n18, 489n15, 579, 581–5,
590, 592–3, 599, 599n3, 599n5, 600n6
Newport, E. L. 502, 504, 738
Newton, Isaac (Sir) 35, 149n44
Nichols, Johanna 61, 66, 68, 71, 77, 83,
86, 139n17, 157n72, 177n142, 207–8,
212n33, 230, 273, 285, 289, 294–5,
299–300, 304–5, 307, 310n3, 310n6,
572n1, 629, 712n11
Niebuhr, Reinhold 129
Niederehe, Hans-Josef
 in Auroux et al. 134n6
 in Embleton et al. 134n6
Nietzsche, Friedrich xi–xii, xviii1
Nikiforidou, Kiki 633

- Nikolajev, Sergeij L. 550n16
 Niyogi, P. 507
 Noble, S. 514
 Norde, Muriel 489n15, 579, 581–3, 593, 601n23
 Notker 543–5
 Novikov, Igor D. 98–9
 Nummedal, Dag 30
- O’Cain, Raymond K. 134n6
 O’Connor, J.
 in Lighter et al. 131n1
 O’Neil, Wayne A. 506
 Oaklander, L. Nathan 90
 Ochman, H.
 in Wilson et al. (1987) 67
 Ockham (Occam), William of 25, 36, 148n41
 Odin (Woden) 137n12
 Odoacer (Odoacar), Flavius
 Ohala, John J. 10, 124, 126, 134n6, 173n128, 208n5, 330, 368n36, 410, 415, 662n6, 662n9, 669, 671–3, 677–8, 681–5, 686n1, 686n4, 686n8
 in Hombert et al. 173n128, 670, 672
 in Plauché et al. 686n4
 Ohala, Manjari 685
 Öhmann, Emil 457n5, 458n7
 Ohtere 164n99
 Olive, J. P. 672
 Oliveira e Silva, G. 514
 Olson, Ronald D. 279
 Orosius, Paulus 164n99
 Orton, Harold 63
 Osborne, C. R. 570
 Osgood, Charles 512
 Ospovat, Dov 149n45
 Osthoff, Hermann 36, 444
 Otte, Daniel 53
 Oubouzar, Erika 543–5, 551n23, 551n25
 Outram, Dorinda 34
 Owens, Jonathan 553
 Ozment, Steven 149n47
- Page, B. Richard 117
 Pagel, Mark D. 68
 Pagliuca, William 79, 81, 577, 607, 615, 622n3, 625, 634
 in Bybee et al. 577–8, 615, 622n3, 624, 629, 632–3, 634–5, 644–5
 Palander-Collin, Minna 646
- Pallas, Peter S. 149n44
 Panagl, Oswald
 in Dressler et al. (1987) 462, 469, 471n1
 Pandora 413
 Pangalos, Georgios E. 482
 Pāṇini 32, 134
 Pappen, Robert A. 707
 Pappas, Panayiotis 138n16, 484, 491n30
 Paracelsus, Philippus A. (= Theophrastus Bombastus von Hohenheim) 32
 Paradis, Carole 342n19
 Pardee, Dennis 242n26
 Paris, Gaston 7
 Parker, Barry R. 99
 Parker, Dorothy 70
 in Bernstein et al. 462, 469, 471n1
 Parker, W. C.
 in Hunter et al. 68
 Parodi, I. G. 314
 Partridge, Eric 132n1
 Passy, Paul 192, 669, 686n5
 Patrick (< Patricius > Cathraig, Padraig; e.g., St) 421n1
 Paul, Christopher R. C. 157n74
 Paul, Hermann 74, 135–6n9, 343, 364n3, 377, 406, 428, 435, 439n3, 444, 458n9–10, 543–4, 550n20, 553, 658–9, 663n16, 664n19, 767
 Pawley, Andrew K. 243n31, 243n35
 Payne, Doris L. 303, 736
 Peace, Warren T. 123–4, 162n90
 Pearce, Elizabeth 503
 Pedersen, Holger 6, 134n6, 405
 Pei, Mario 164n98
 Peirce, C. S. S. 216, 240n8, 428, 431, 433, 434, 438, 439n7, 463, 465
 Pensado Ruiz, Carmen 465, 468
 Percival, Keith 209n6
 Pérez, A. 634
 Pericles 86
 Perkins, Revere D.
 in Bybee et al. 577, 578, 589, 615, 622, 624, 629, 632–5, 644
 Pesetsky, David
 in Barbosa et al. 141n21
 Peterson, David A. 295, 299, 307, 310n3, 310n6
 Peterson, Gordon 672
 Peterson, Steven A. 52
 Pfaff, Carol 695
 Philippaki-Warburton, Irene 133n3

- Phillips, Betty 392
Picard, Marc 261n25
Pickering, J. B.
 in Bladon et al. 673
Pickett, George E. (General) 9
Pickett, J. M. 675
Pickett, Joseph P. 162–3n95
Pickett, LaSalle Corbell 9
Pickover, Clifford A. 99
Pierce, Joe E. 271
Pillbeam, D. R.
 in Harrison et al. 70
Pinker, Steven 86, 662n8
 in Kim et al. 743
Pintzuk, Susan 14, 120–1, 125, 140n21,
 159n78, 206, 397, 400n5, 462, 492n39,
 496, 505, 510–11, 514, 517–18, 526n2,
 527n5, 527n9, 527n14
Plag, Ingo 578, 583
Plank, Frans 34, 286, 461
 in Naumann et al. 34
Platnick, Norman I. 68
Plato 10, 171n121
Plauché, Madelaine 686, 686n4
Playfair, John 34
Plog, Fred T. 151n53
Plummer, Charles 526
Poitier, Gilbert of (Bishop) 138n14
Pollard, Carl J. 221
Pollock, Jean-Eves 498
Polomé, Edgar C. 177n142
Polybius 119
Pomorska Jakobson, Krystyna 146–7n36
Pope, Alexander 89–90
Pope, John Collins 525, 682
Popescu, Sandu
 in Aharonov et al. 98
Poplack, Shana 578
Popper, Karl R. (Sir) 179n149
Porter, Roy 35
Portolés, José xvi
Poser, William 320
Posner, Rebecca 84, 122, 162n93, 179n149,
 407–8
Postal, Paul M. 74–5
Powell, Mava Jo 646n8
Prager, E. M.
 in Wilson et al. (1987) 67
Press, Ian 5
Preston, Richard (Viscount) 641
Price, Huw 91, 99
Priestley, L. 514
Prince, Alan S. 382, 409
Probius, Valerius 18, 145n33
Prokosch, Eduard 115
Provine, William B. 52
Prunet, Jean-François 342n19
Psicharis, Jean 481
Pulleyblank, Douglas 340n7
Pullum, Geoffrey K. 478, 480, 483
Pustet, Regina 210–11n22
Pyles, Thomas 717
Queen, Robin M. 702–3, 711n4
Quilis, A. 682
Quintero, Carolyn 210–11n22
Rackham, H. Harris 11
Radin, Paul 144n30
Rahden, Wolfert von 148–9n44
Ramat, Paolo 577, 582, 627, 629, 638
Ranke, Leopold von 107
Rankin, Robert L. 21, 85, 116–18, 141n22,
 159n79, 191, 210n17, 239n1, 244,
 279–80, 281n1, 472, 486
 in Carter et al. 210n17
Ransom, Evelyn N. 578
Raphael, Lawrence J.
 in Bronstein et al. xiv, 134n6
Rapp, K. M. 670
Rask, Rasmus 134n6, 457n6
Rathje, William L. 18, 145n32
Rauch, Irmengard 141n22
Raumer, R. von 670
Raup, David M. 31, 52
Ravel, J. Maurice 45
Reardon, Carol 9
Reeds, James A.
 in Winitz et al. 673, 674t
Rees, Nigel 89
Regnaud, Paul 9
Reh, Mechthild 577, 589, 593, 618, 625, 631,
 636
Reichenbach, Hans 91
Reicke, Bo 137n12
Reiss, Charles 367n26, 368n37
Remmes, Beth xii
Renfrew, Colin 63, 145n31, 166n107,
 174n132
Repp, Bruno H. 675
Revere, Paul xiv
Reynolds, William (Bill) 175n135, 743

- Reznick, David N. 60
 Riad, Tomas 327
 Rice, Keren 5
 Rice, Muriel 569–70
 Rich, Edwin E. 64
 Richards, Brian J. 502
 Richardson, Brian
 in Walker et al. 170n120
 Richardson, James D. 3
 Rickford, Donald 142–3n25
 Ridley, Mark 73, 160n83
 Riemann, Hugo
 in Thayer et al. xiv, xviii n4
 Riemsdijk, Henk van 528n17
 Rimini, Gregory of (Augustinian vicar-general) 138n14
 Ringe, Donald A. 85, 94, 109, 141n22, 186, 240n3, 242n27, 268, 272, 274–5, 663n15
 Rissanen, Matti 646
 Ritt, Nikolaus 156n70
 Rivierre, Jean-Claude 355–6, 360, 367n28
 Roberts, Ian G. 499, 500–3, 506, 527n5
 Roberts, Julie 49, 738
 Roberts, Sydney C. 176–7n141
 Robins, Robert H. 134n6
 Robson, Barbara 174n133
 Rock, Irvin 675
 Rodd, Frieda H.
 in Reznick et al. 60
 Rodgers, Richard 178n148
 Rodman, Robert 737
 Rogers, Inge
 in Guy et al. 117, 385, 388, 398
 Rogers, M. E. 714–15, 727
 Rognvaldsson, E. 525
 Rohrbacher, Bernhard 499
 Röll, Viktor (Dr Freiherr) 154n66
 Romaine, Suzanne 77, 578, 590, 646n8, 738
 Romulus August(ul)us, Flavius Momyllus (Emperor) 164n100
 Ronnenberger-Sibold, Elke 468
 Ronsard, Pierre de 127
 Rood, David S. 210n20, 210n22, 211n28
 Rosapelly, Ch.-L. 670
 Rosch, Elinor 415
 Rose, Pete(r) 637
 Ross, Malcolm D. 209n9, 209n11, 360
 Rott, W.
 in Altmann et al. 512
 Rousseau, Jean Jacques 149n44
 Rousseau, Pascale 374
 Rousselot, Pierre-Jean (l'abbé) 670
 Rowe, Maude 210–11n22
 Rubba, Jo 661n2
 Rudin, Catherine 211n27
 Rudwick, Martin J. S. 8, 34–5, 136n9, 148–9n44, 149n45
 Ruhlen, Merritt 217, 262, 272–3, 277, 282n4, 342n22
 Ruse, Michael 73, 157n71
 Russell, Bertrand (Earl Russell) 38–9, 108, 150–1n49
 Russom, Jacqueline Haring 15
 Rybczynski, Witold 107–8
 Ryle, Gilbert 178n147
 Rymer, Hazel 12
 Sag, Ivan 221
 Saki *see* Hector H. Munro
 Salm, Max 434, 435
 Salmons, Joseph C. 94, 147n37, 172n127
 Salthe, Stanley N. 81
 Salwen, Bert 145n32
 Sampson, Geoffrey 134n6
 Sand, Lori
 in Bailey et al. (1993) 386, 718, 720, 725–9, 730–1f, 732
 Sandalo, Filomena 700
 Sandfeld, Kristian 693
 Sankoff, David 373–4, 376, 511
 Sankoff, Gillian Topham 72, 578
 Santayana, George 114, 170n120
 Santorini, Beatrice 397, 505, 510–11, 514, 517–18
 Sapir, Edward 170–1n121, 269–70
 Sarich, Vincent M.
 in Wilson et al. (1974) 67
 Sasse, Hans-Jürgen 708
 Saturn 137n12
 Saussure, Horace-Bénédict de 149n44
 Saussure, Mongin-Ferdinand de 4–5, 7, 146–7n36, 168–9n116, 175–6n138, 216, 313, 398–9, 434, 444
 Savan, David 440n12
 Savitt, Steven F. 90–1
 Saxena, Anju 578
 Schaller, Helmut W. 693
 Schane, Sanford A. 210n17, 331, 677
 Scheib, M. E.
 in Winitz et al. 673, 674t
 Scheibman, Joanne 617–18
 Schelling, Friedrich J. W. von 7

- Scherer, Wilhelm 443
Schickele, Peter xi
Schiffirin, Deborah 638–9, 642–3
Schilling-Estes, Natalie 10, 41, 62, 120,
158n75, 462, 687, 716, 717, 719, 726, 732
in Wolfram et al. 717, 726
Schladt, Mathias 578
Schlegel, August W. von 576
Schlegel, K. W. Friedrich von 7, 8, 10, 443
Schleicher, August 7–8, 10, 93, 106, 111,
134–5n8, 135n9, 166n106, 444, 458n8
Schlink, Bernhard 128
Schmidt, Johannes 135n8, 721, 733n1
Schoenner, Thomas W.
in Losos et al. 60
Schourup, Lawrence 177–8n145, 342n22
Schuchardt, Hugo E. M. xv–xvi, xviii n5,
115, 185, 209n6, 314, 450, 452, 455,
459n24
Schwartz, Jeffrey H. 50
Schwenter, Scott A. 636, 646, 646n9
Scotland, Robert W. 158n74
Scott, Thomas 155n69
Scotton, Carol Myers 171–2n125
Scrope, George P. 149n44
Sebeok, Thomas A. 134n6, 512
Sècheyhayé, Albert 175–6n138
Seider Story, Robin
in Löfqvist et al. 173n128, 670
Seiler, Hansjakob 469
Sekerina, Irina A. 708
Seliger, Herbert 174n133
Selvin, Steve 290
Seuren, Pieter A. M. 134n6
Sgall, Petr 467
Shakespeare, William 88–9, 102, 164n98
Shapiro, Marianne 439n7
Shapiro, Michael 13, 429, 430, 439n7
Shaw, F. H.
in Reznick et al. 60
Shaw, Henry Wheeler *see* Josh Billings
Shaw, R. G.
in Reznick et al. 60
Shea, Kathy 210n22
Sheldon, P. R. 157n71
Shepherd, Susan C. 632
Sherburne, Donald W. 158–9n76
Shevoroshkin, Vitaly 262, 271–2
Shibatani, Masayoshi 158n76
Shigley-Giusti, Michela 697–8
Short, Thomas L. 429, 434
Shorter, Edward 149n47
Siebert, Darrell J.
in Scotland et al. 158n74
Siebert, Frank T., Jr 118
Siemund, Peter 578
Sieviers, Eduard 192
Sigwardsson 637
Sigurðsson, G.
in Kristjánsdóttir et al. 527n10
Sihler, Andrew L. 177n142, 243n38, 260n15,
451
Silverstein, Michael 96, 557
Simmel, Georg 23, 122–3
Simon, C. M. 157n71
Simpson, George G. 99, 149n45
Simpson, James M. Y. 173n128
Skalička, V. 467
Skeat, Walter W. 526
Slagle, Uhlán von 439n7
Slatkin, Montgomery
in Charlesworth et al. 157n71
Slobin, Dan I. 626, 630, 738
Smart, John J. C. 96
Smith, Adam 553, 554
Smith, J. W. 96
Smith, N. J. J. 96
Smith, Norval S. H. 133n3
Smith, Quentin 90
Smith, Robert F. 14
Smith-Stark, Thomas
in Campbell et al. 304, 309–10, 693
Smolensky, Paul 382, 408
Smyth, Herbert W. 247, 260n11
Soares, Carlos 698
Sober, Elliot 35, 50, 54, 73, 112–13
Socrates 10, 250
Solé, Maria-Josep 686
Solomon (king of Israel) 636
Somit, Albert 52
Sommerstein, Alan H. 86
Sonderegger, Stefan 18
Sørensen, Marie Louise S. 153n64
Sosa, Juan Manuel 616
Spade, Paul V. 148n41
Spencer, Andrew 6, 170n121
Sperry, R. 138–9n17, 500
Spiegel, Arthur 637
Sproat, Richard 671
Sprouse, Rex A. 503
Stammerjohann, Harro 134n6
Stampe, David 462

- Stanley, Steven M. 50, 52, 54, 66
 Starostin, Sergej A. 550n16
 Stearns, Stephen C. 160n83
 Stebbins, G. Ledyard 55, 66–8, 72, 157n71,
 161n84
 Steiner, Richard
 in Labov et al. 378, 397, 714, 727
 Steno, Nicolaus 149n44
 Stenseth, Nils C. 157n71
 Steriade, Donca 340n5, 342n20
 Stern, Gustaf 664n16, 664n19
 Stevens, C. J.
 in Bronstein et al. xiv, 134n6
 Stewart, William A. 505
 Stockwell, Robert P. 63, 335
 Stokoe, William F.
 in Armstrong et al. 116
 Stolz, Thomas 470
 Stone, Lawrence 149n47
 Strauß, Udo
 in Altmann et al. 512
 Stravinsky, Igor F. 125
 Strickberger, Monroe W. 160n83
 Strobach, Niko 39, 151n49
 Strong, Herbert A. 136n9
 Studdert-Kennedy, Michael 116
 Sturtevant, Edgar H. 185, 444, 450, 452,
 459n11
 Suárez, Jorge 570
 Sugita, H.
 in Avise et al. 160–1n83
 Sun, Chaofen 577
 Supalla, Samuel J. 504
 Sussman, Harvey M. 671
 Svantesson, Jan-Olof 672
 Svorou, Soteria 578, 636
 Swadesh, Morris 173n129, 263, 270–2,
 282n6, 291
 Swanton, John R. 210n21, 211n28
 Sweet, Henry 526, 669, 737
 Sweetser, Eve E. 587, 591, 632, 633
 Swift, Jonathan (Dean) 146n36
 Swinburne, Richard 90
 Syea, Anand 578
 Sykes, Bryan 116
 Syrdal, A. K. 672
 Szemerényi, Oswald 247

 Taavitsainen, Irma 647n17
 Tabor, Whitney 626, 630, 634, 638, 643, 646,
 743
 Tagliamonte, Sali 578
 Talmy, Leonard 632
 Tamburino, Louis
 in Newman et al. 98
 Tanner, J. M.
 in Harrison et al. 70
 Tarallo, Fernando 383
 Tatian 542, 551n24
 Tatlock, J. S. P. 611
 Taylor, Ann 505, 510–11, 514–15, 517, 524,
 527n14
 Teeter, Emily 105
 Teeter, Karl V. 228–9, 241–2n18, 269–70
 Thagard, Paul 432, 434, 438, 439n2, 440n8–9
 Thal, Donna
 in Bates et al. 174n133
 Thayer, Alexander Wheelock xiv, xviii n4
 Thibault, Pierrette 385
 Thiele, Petra 470
 Thom, René 128, 139n17, 508n2
 Thomas-Flinders, Tracy G. 406
 Thomason, Sarah G. 10, 72–3, 118, 120,
 123, 155n68, 159n77, 162n94, 214, 229,
 239n2, 241n14, 283, 290, 458n7, 690–2,
 700, 703–4, 707–8, 711n2, 711n4
 Thompson, Sandra A. 565, 619, 621, 646n7,
 693
 Thomson, Iain 136n10
 Thor 137n12
 Thorne, Kip S. 98–9
 in Morris et al. 98
 Thorsson, Ö.
 in Halldórsson et al. 527n10
 in Kristjánsdóttir et al. 527n10
 Thráinsson, Höskuldur 509–10
 in Epstein et al. 366n20
 Thucydides 250
 Thurneysen, Rudolf 663n15
 Tieken-Boon van Ostade, Ingrid 502
 Tiersma, Peter Meijes 459n15
 Tillery, Jan
 in Bailey et al. (1993) 386, 718, 720,
 725–9, 730–1f, 732
 Timberlake, Alan 536–7, 549n6, 629
 Timmers, Corine 453
 Tinbergen, Niko 138–9n17
 Tipler, Frank J. 98–9
 Tiu (Tiw) 137n12
 Tokaryk, Timothy T.
 in Chin et al. 18
 Tolstoy, Leo N. 162n90

- Tómasson, S.
 in Halldórsson et al. 527n10
 in Kristjánsdóttir et al. 527n10
- Tomlin, Russell S. 740
- Tonelli, Livia 471n1
- Tooke, John Horne 576
- Torfason, J.
 in Halldórsson et al. 527n10
 in Kristjánsdóttir et al. 527n10
- Tort, Patrick 7, 135n8
- Toynbee, Arnold J. 179n149
- Trager, George L. 454
- Trask, Robert L. 117, 166–7n108, 168–9n116,
 177n142, 291, 411–12, 444, 449, 651,
 661n1
 in Renfrew et al. 166n107
- Traugott, Elizabeth Closs 75–6, 79, 116,
 121, 125–6, 206, 208n3, 241n14, 365n5,
 430, 449–50, 459n19, 472–3, 477–8,
 484, 488n4–5, 490n18, 490n23, 491n24,
 492n36, 492n40, 505, 527n14, 572n2,
 577–8, 580–1, 587–9, 591–3, 599, 600n6,
 601n22, 602–3, 622, 624–5, 629–30,
 632–4, 636, 643, 646, 647n11, 656–8,
 666n34, 740
- Travisano, Michael 59
- Tredennick, Hugh 24
- Trigger, Bruce G. 178n146
- Trudgill, Peter 72, 722, 724–7, 734n7,
 734n10, 734n12
- Truebner, N. 526
- Trumbach, Randolph 149n47
- Tsiapera, Mária 136–7n11
- Tsoulas, George 526
- Tudge, Colin 68
- Turetzky, Philip 39, 90, 138n14, 146n36
- Turgot, Anne-Robert-Jacques 149n44
- Turner, J. R. G. 157n71
- Twaddell, W. Freeman 409–13
- Twain, Mark (= Samuel L. Clemens) 409–10
- Tyndall, John 42–3
- Ullmann, Stephen 665n22
- Ultan, Russell 331
- Unti, Theodore
 in Newman et al. 98
- Updike, John H. 115
- Vago, Robert 174n133
- Vaidman, Lev
 in Aharonov et al. 98
- Vakhtin, Nikolai B. 707
- Valiquette, Philippe L. 243n34
- Van Coevering 148n42
- Van Valen, Leigh M. 66
- Van Valin, Robert D. 646n7
- Vance, Barbara 132–3n2, 503, 508n3, 518
- Vance, Timothy 124
- Varela-García, Fabiola 177–8n145, 408,
 421n4
- Varro Marcus Terentius 457n4
- Vaught, Carl G. 431, 434
- Vendryès, Joseph 144n30
- Vennemann, Theo 435, 445–6, 459n24, 463,
 683
- Venus (Aphrodite) 137n12
- Verburg, Pieter A. 137n11
- Verner, Karl 115, 134n6, 207
- Versteegh, Kees
 in Auroux et al. 134n6
- Vico, Giambattista 8
- Viëtor, Wilhelm 669
- Vihman, Marilyn May 174n133, 738
- Vihvelin, K. 97
- Vincent, Diane 385, 643
- Vincent, Nigel B. 542, 545
- Vinson, Julien 9
- Virgil (Vergil; Publius Vergilius Maro)
 251
- Visser, F. Th. 527n14
- Vleeskruyer, R. 526
- Vogel, Irene 460n26
- Vogt, Hans 174n131, 230
- Voltaire (né François Marie Arouet) 69,
 161n85
- Vonwiller, Julia
 in Guy et al. 117, 385, 388, 398
- Votre, Sebastião
 in Vincent et al. 643
- Voyles, Joseph 415
- Vrba, Elisabeth S. 50, 53
- Wackernagel, Jacob (/Jakob) 204
- Walker, Felix 132n1
- Walker, Leslie J. 170n120
- Wallace, Rex E. 145n33, 147n37
- Wallerstein, Immanuel M. 107
- Wang, William S.-Y. 77, 115, 185, 214, 314,
 403, 420, 452–3, 452n24
 in Fillmore et al. 174n133
- Wanner, Dieter 341n14
- Ward, Adolphus W. (Sir) 176–7n141

- Wahrheit, K. I.
 in Losos et al. 60
 Warner, Anthony R. 497, 501–3, 513, 526,
 626, 635
 Warren, R. M. 681
 Wårwick, Brita 647n16
 Wasow, Thomas 141–2n23, 742
 Waterman, John T. 134n6
 Watkins, Calvert 22, 93, 109, 115–16,
 133–4n5, 166n107, 174n132, 201, 203–5,
 268, 446
 Weerman, Fred 528n20
 Weigel, William F.
 in Ohala et al. 134n6
 Weinberg, Gerhard L. xiii–xiv, xviii3, 111,
 142n25, 143n28, 149n46
 Weinberg, Steven 32
 Weiner, Jonathan 60
 Weinhandl, Ferdinand 429
 Weinreich, Uriel 77–8, 119–20, 123, 157n79,
 214, 369, 371, 373, 401, 510, 512, 654,
 662n9, 684, 690, 714, 716, 720, 733n2
 Welby, Pauline xii
 Wells, Herbert G. 96–7
 Wells, Peter S. 104
 Wells, Rulon 7, 16, 29, 162n91
 Welmers, William E. 341n19
 Wescott, Roger 171n123
 Wetzels, W. Leo
 in Hinskens et al. 175n135
 Wexler, Kenneth 500
 Weymouth, R. F. 670
 Whatmough, Joshua 54
 Wheeler, Charles N. 3
 Wheeler, Quentin D. 53, 158n75, 444, 469
 Whewell, William 27, 35, 148–9n44
 White, Jane G.
 in Haft et al. 148n41
 White, Michael J. D. 53
 White, Robert J.
 in Haft et al. 148n41
 Whitehead, Alfred N. 158–9n76
 Whitney, William Dwight 576
 Whitrow, Gerald J. 90, 137n12, 146n36
 Whorf, Benjamin L. 225
 Wiesel, T. 139n17, 500
 Wikle, Tom
 in Bailey et al. (1993) 386, 718, 720,
 725–9, 730–1f, 732
 Wilbur, Richard
 in Bernstein et al. 70
 Wilcox, Sherman E.
 in Armstrong et al. 116
 Wiley, Edward O. 55, 139n17
 Wilford, John N. 104
 Wilkins, John 149n44
 Willerman, R.
 in Lindblom et al. 683
 Willett, Thomas 578
 Williams, David M.
 in Scotland et al. 158n74
 Williams, Donald C. 96
 Williams, Joseph M. 666n34
 Williams, Parrish 210n22
 Williamson, Kay 300
 Williamson, Peter 50
 Williram 551n24
 Willis, R. 670
 Wilmut, Ian 156n70
 Wils, Johannes 135n9
 Wilson, Allan C. 67
 Wilson, Leonard G. 149n45
 Wilson, Michael R.
 in Claridge et al. 53
 Wilson, Robert A. 40, 690
 Windisch, Ernst 136–7n11
 Winford, Donald 142–3n25
 Winitz, Harris 673–4
 Winter, Werner 201, 428
 Winters, Margaret E. 445, 447
 Witkowski, Stanley R. 280
 Wolde, Ellen van 434
 Wolf (*lupus*) 639
 Wolff, Roland A. 176n140, 407
 Wolfram, Walt 10, 41, 62, 120, 158n75,
 168n115, 462, 687, 716–17, 719, 726,
 732
 Woolard, Kathryn A. 704, 711n7
 Wooton, David 69
 Wright, Frank Lloyd 136n10
 Wright, Sewall 52, 62–3
 Wulfila (Ulfilas) 143n28
 Wulfstan 164n99
 Wüllner, Franz 576
 Wurff, Wim van der 527n5
 Wurzel, Wolfgang 435, 462, 465, 467–8,
 471n1–2
 in Dressler et al. (1987) 462, 469, 471n1
 Wyatt, William F., Jr 94
 Wycliffe, John 640
 Xenophon 250

- Yaeger(-Dror), Malcah
in Labov et al. 378, 392, 397, 714,
727
- Yakhontov, Sergei 291
- Yang, Xiangning 66
- Yurtsever, U.
in Morris et al. 98
- Zaborowski-Moindron, Sigismond 9
- Zec, Draga 330
- Zelinsky, Wilbur 72
- Zgusta, Ladislav 106
- Zheng, Guoqiao 709
- Zhou En-lai 125
- Zhu, Wanjin 171–2n125
- Zieglschmid, Andreas J. F. 550n21
- Zinder, L. R. 330
- Zobl, Helmut 77
- Zubritskaya, (Ekaterina [Katya]) L.
175n135, 743
- Zwart, C. Jan-Wouter 366n20
- Zwicky, Arnold M. 6, 170n121, 404–5, 478,
480, 483, 491n25, 625, 629, 634, 646,
647n15

Language Index

Note: f = figure, n = note, t = table. A very few languages with a large number of Subject Index entries are simply mentioned by name here but with cross-references to fuller entries in the Subject Index.

- AAVE *see* African American Vernacular English
African American Vernacular English (AAVE) 143n25, 699, 711n5
African languages 126, 580, 590, 595, 597, 599, 703, 704, 708
Afro-Asiatic languages 300, 301
Aleut 561–7, 707–8
Algonquian languages 166n105, 256–7, 269
American English 454, 455, 618, 717–18, 718t, 721–2, 734n6
American Sign Language 113, 140n20
Amerind 276, 277
Ancient Greek 147n37, 229, 243n34, 247–50, 260n11, 510, 517
Arabic 242n26, 585, 708
Armenian 205
Australian English 388, 388f
Austronesian 22, 126, 209n9
Ayul 538–41
- Baka 577
Balto-Slavic 172n127
Bantu 300, 597–8, 672, 703, 708
Biloxi 190t, 194t, 196, 197, 202, 203, 211n24, 211n28
Burmese 188t
- Canadian French 486, 492n39
Canala 231
- Caucasian languages 126, 296t, 301, 301t, 302t, 303, 310n5, 538–41, 550n16
Cayuga 567–8, 571
Celtic languages 405–6
Chinese 188t, 277, 577, 659, 709
Chontal 570
Crow 190t, 194t, 196, 199t, 200t, 202, 203
- Dakotan 190t, 194t, 196, 199t, 200t, 211n24
Danish 502
Dhegihan (Siouan) 190t, 193, 194t, 196, 199t, 200t, 202, 203, 211n24, 211n27, 211n28
Dutch 502, 516, 725
- East Asian languages 188t
English *see* entry in *Subject Index*
Eskimoan languages 554–8, 558–61, 561–7, 572n3
Estonian 176n140, 468, 629
Ewe 277
- Finnish 271, 292, 451, 537
Flemish 725
French *see* entry in *Subject Index*
- Georgian 533–6, 537, 546, 549n8
German *see* entry in *Subject Index*
Gilbertese 225, 227, 228, 243n30
Gothic 27, 205

- Grand Couli 231
Greek *see entry in Subject Index*
Guaraní 570
- Hebrew 224
Hidatsa 190t
Hittite 156n69, 243n33
Huave 570
Hungarian 705–6
- Icelandic 525
Indo-European *see entry in Subject Index*
Ingush 302t, 310n5
Ioway-Otoe 190t, 193, 194t, 196
Iranian 229, 243n34
Iroquoian languages 65, 567–8, 571
- Japanese 124, 188t, 342n21, 384–5, 385f, 629
- Kadiwéu 700
Kamchadal 570
Kammu 672
Kansa 190t, 193, 194t, 196, 199t, 200t, 211n24, 211n28
Kapampangan 565
Kartvelian 296t
K'iche' 270
Korean 188t
Kupwar Marathi 690
Kupwar Urdu 690
- Lakota 194t, 202, 203
Lappish *see Saame*
Latin 145n33, 155n69, 169n118, 226, 242n28, 250–3, 260n16, 467, 506
Lithuanian 229
- Ma'a (Tanzania) 703, 704, 708
Mandan 190t, 194t, 196
Manually Coded English (MCE) 504
Maori 347, 365n16
Marathi 690
Mayan languages 270, 279, 280
MCE *see Manually Coded English*
Media Lengua (Ecuador) 707
Mednyj Aleut (Commander Islands) 707–8
Mehri 242n26
Mesoamerican languages 279, 280, 309, 570, 693
Mexicano 309
- Michif (Canada) 707–8
Micronesian languages 224, 225, 227, 228, 243n30, 243n37
Mohawk 568–9, 571
Mokilese 224, 228
Mon-Khmer languages 329
Mongolian 204
Montana Salish 689, 704
- Nahuatl 531
Nakh-Daghestanian 292–5, 293t, 301, 301t, 303
Netherlandic 259n2
New Caledonian languages 231, 232, 355, 356, 367n28
New York City English 391–2, 397
Niger-Congo languages 276, 300, 597–8, 672, 703, 708
Northwest Caucasian 296t
- Occitan 341n16, 360
Oceanic languages 231, 232, 243n30
see also Micronesian languages
Ofo 190t, 194t, 197, 210n21
Ojibwa 256–7
Old English *see entry in Subject Index*
Old High German 18, 19
Old Indic 470
see also Sanskrit; Vedic
Omaha 190t, 193, 194t, 196, 203, 211n24, 211n28
Osage 190t, 193, 194t, 196, 199t, 200t, 211n24
- Pacific Rim languages 299
Philadelphia English 17, 321–6, 351–4, 386–7, 387f, 391, 392, 400n9
Philippine languages 565
Polish 229, 259n2, 334, 466
Ponapean 224, 225, 228
Ponca 190t, 193, 199t, 200t, 202, 211n28
Portuguese 226, 374, 375, 376, 382, 514
Prakrit 681
Proto-Central Algonquian 166n105
Proto-Indo-European 92, 106, 134n5
Proto-Micronesian 228
Proto-Polynesian 347
Proto-Siouan 193, 194t, 195, 196, 203
- Quapaw 190t, 193, 194t, 196, 199t, 200t
Quechua 270, 570

- Romance languages 226, 236, 254, 467,
472–3, 479, 488n6
- Romansh 690
- Rotuman 232
- Russian 259n2, 333, 570, 677, 701
- Saame (Lappish) 485
- Sanskrit xvi, 243n33, 454, 455, 681
- Scandinavian languages 502, 509, 516,
579
- Semitic languages 242n26
- Serbo-Croatian 690, 700
- Siberian languages 570
- Siouan languages 190t, 193, 194t, 195, 196,
197, 198, 199t, 200t, 201, 202, 203, 206,
210n17, 210n19, 210n21, 211n23,
211n24, 211n27, 211n28
- Slavic 205, 210n19, 327, 417–19
- Soqotri 242n26
- South American languages 276, 277, 570,
739
- Spanish *see entry in Subject Index*
- Swahili 580, 585, 586, 590, 600n16
- Swedish 502, 579
- Swiss German 454
- Tequistlatec-Jicaque languages 570
- Thai 188t, 696
- Tibetan 188t
- Tiwi 570
- Tojolabal 570
- Tok Pisin 739
- Trukic 228
- Turkic 308
- Tutelo 190t, 194t, 196, 197
- Tzotzil 570
- Ugaritic 242n26
- Ukrainian 333
- Uralic 701
- Urdu 690
- Vedic (Sanskrit) 243n33
- Vulgar Latin 145n33, 155n69, 169n118
- Winnebago 190t, 193, 194t, 206
- Wiyot 269
- Yiddish 510, 514, 517
- Yup'ik 558–61, 572n3
- Yurok 269