

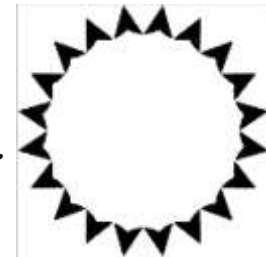

*PEF2602*  
*Estruturas na Arquitetura I I - Sistemas Reticulados*



# *Arcos e Cabos - II*

*(Aula 6 - 01/10/2018)*

*Professores*

*Ruy Marcelo Pauletti, Leila Meneghetti Valverdes, Luís Antônio Bittencourt Jr.*

## Cabo Poligonal, sujeito a forças verticais, com apoios nivelados:

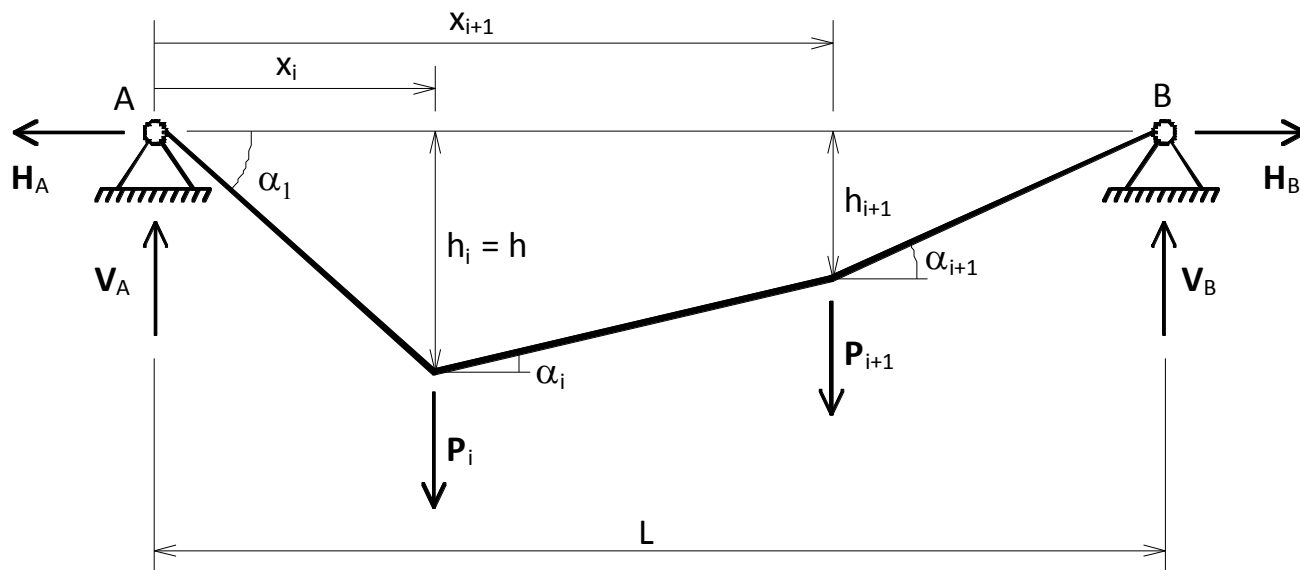

Equilíbrio vertical :  $V_A + V_B - \sum_i P_i = 0$

Equilíbrio horizontal:  $H_B - H_A = 0$   $H_A = H_B = H$  (Empuxo)

Equilíbrio de Momentos em torno de A:

$$V_B L - \sum P_i x_i = 0$$

$V_B = \frac{1}{L} \sum P_i x_i$

Equilíbrio de Momentos em torno de B:

$$-V_A L + \sum P_i (L - x_i) = 0$$

$V_A = \frac{1}{L} \sum P_i (L - x_i)$



## Cabo Poligonal, sujeito a forças verticais, com apoios nivelados:

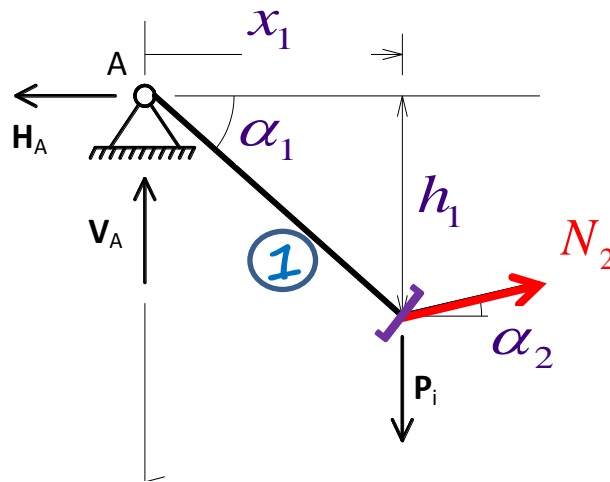

Fixando o valor de  $h_1$  (ou de outro  $h_i$  qualquer, determinamos o valor do empuxo:

$$\sum_i M_{(S1)} = Hh_1 - V_A x_1 = 0$$

$$H = \frac{V_A x_1}{h_1}$$

Decorre o esforço  $N_1$ :  $N_1 = \sqrt{H^2 + V_A^2}$

Ou, de outro modo:  $N_1 \cos \alpha_1 = H$   $N_1 = \frac{H}{\cos \alpha_1}$

Sendo que:  $\cos \alpha_i = \frac{x_i - x_{i-1}}{l_i} = \frac{\Delta x_i}{l_i} = \frac{\Delta x_i}{\sqrt{(\Delta x_i)^2 + (\Delta y_i)^2}}$



## Cabo Poligonal, sujeito a forças verticais, com apoios nivelados:

Determinado o empuxo  $H$ , as demais alturas  $h_i$  são decorrência, bem como as forças normais  $N_i$ :

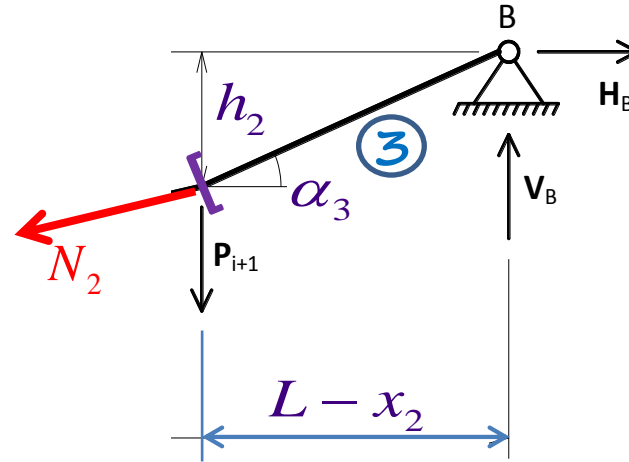

$$\sum_i M_{(S_2)} = V_B (L - x_2) - H h_2 = 0$$

$$h_2 = \frac{V_B (L - x_2)}{H}$$



## Cabo Poligonal, sujeito a forças verticais, com apoios nivelados:

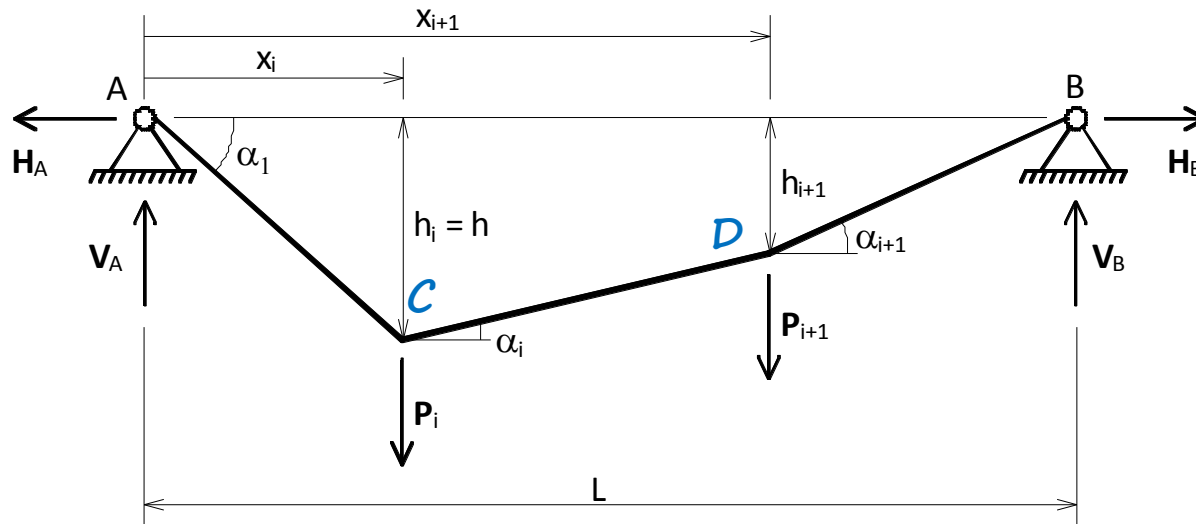

Equilíbrio do Nó C:  $\sum F_x = N_2 \cos \alpha_2 - N_1 \cos \alpha_1 = 0$

$$N_2 \cos \alpha_2 = N_1 \cos \alpha_1 = H$$

Em geral, para cargas verticais:

$$N_i \cos \alpha_i = H = \text{constante!}$$

Logo, para as forças normais:

$$N_i = \frac{H}{\cos \alpha_i}$$

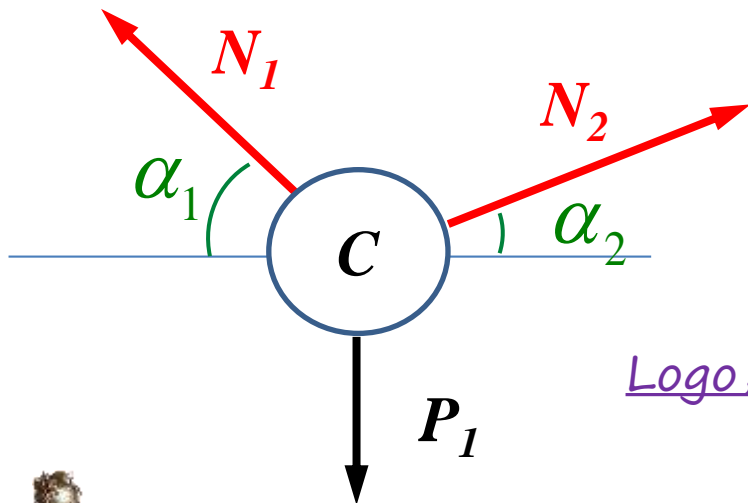

Exemplo: O cabo da figura ao lado encontra-se sujeita à ação de cargas verticais, múltiplas de  $P=275\text{kN}$ . Determine as forças normais em cada trecho do cabo e as alturas  $y_C$  e  $y_E$ . Considerando que o material do cabo possui tensão de ruptura  $\sigma_R = 40\text{ kN/cm}^2$ , determine o diâmetro de sua seção transversal (uniforme), utilizando um coeficiente de segurança  $s=2$ .

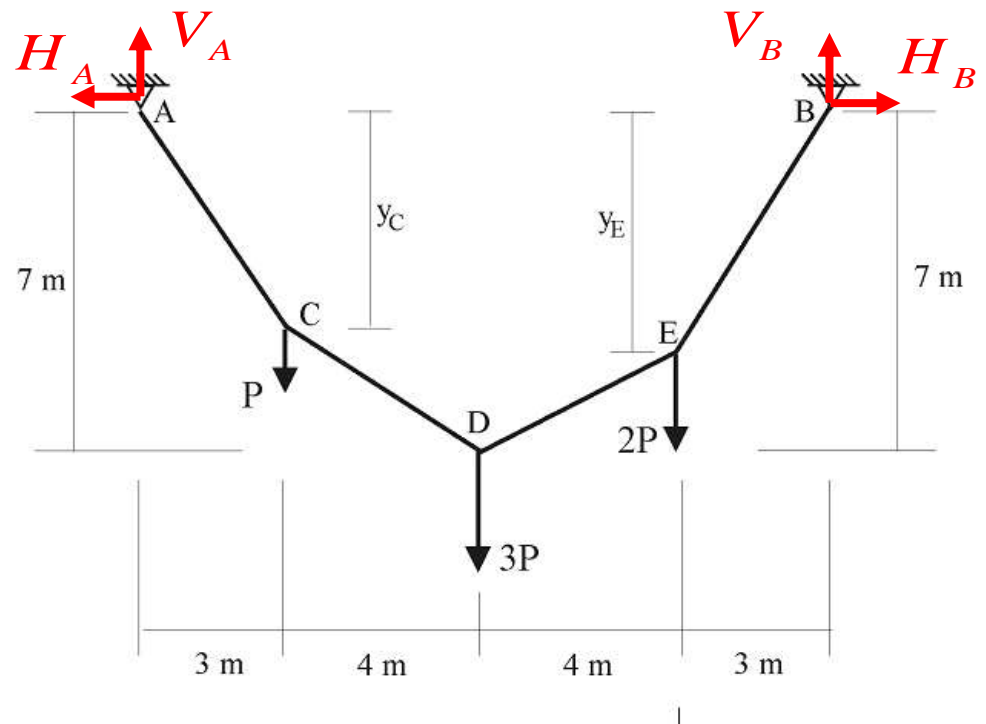

Equilíbrio horizontal:

$$\sum_i F_X^i = H_B - H_A = 0$$

$$H_A = H_B = H$$

Equilíbrio vertical :  $V_A + V_B - P - 3P - 2P = 0$

$$V_A + V_B = 6P = 6 \times 275 = 1650\text{kN}$$

Equilíbrio de Momentos em torno de A:  $V_B \times 14 - P \times 3 - 3P \times 7 - 2P \times 11 = 0$

$$V_B = \frac{275}{14} (3 + 3 \times 7 + 2 \times 11) = 903,57\text{kN}$$

$$V_A = 1650 - 903,57 = 746,43\text{kN}$$



Equilíbrio de momentos do trecho ACD em relação ao ponto D

$$\sum_i M_{(D)} = H \times y_D - V_A \times 7 + P \times 4 = 0$$

$$H = \frac{1}{7}(746,43 \times 7 - 275 \times 4) = 589,29 \text{ kN}$$

Equilíbrio de momentos do trecho AC em relação ao ponto C

$$\sum M_{(C)} = H \times y_C - V_A \times 3 = 0 \quad y_C = \frac{746,43 \times 3}{589,29} = 3,8 \text{ m}$$

Equilíbrio de momentos do trecho BE em relação ao ponto E

$$\sum M_{(E)} = -H \times y_E + V_B \times 3 = 0 \quad y_E = \frac{903,57 \times 3}{589,29} = 4,6 \text{ m}$$



Forças normais:

$$N_i = \frac{H}{\cos \alpha_i}$$

$$\cos \alpha_i = \frac{\Delta x_i}{\sqrt{\Delta x_i^2 + \Delta y_i^2}}$$

Trecho	$\Delta x$ [m]	$\Delta y$ [m]	$\Delta L$ [m]	$\cos \alpha$	N [kN]
AC	3	3,8	4,84	0,6196	951,1
CD	4	3,2	5,12	0,7809	754,6
DE	4	2,4	4,66	0,8575	687,2
EB	3	4,6	5,49	0,5463	1078,7

Dimensionamento:

$$N_{\max} = N_{EB} = 1078,7 \text{ kN}$$

$$\sigma_{\max} = \frac{N_{\max}}{A} = \frac{N_{\max}}{\left(\frac{\pi \phi^2}{4}\right)} \leq \frac{\sigma_R}{s}$$

$$\sigma_R = 40 \frac{\text{kN}}{\text{cm}^2} \times \left(10^3 \frac{\text{N}}{\text{kN}}\right) \times \left(10^4 \frac{\text{cm}^2}{\text{m}^2}\right) = 400 \times 10^6 \frac{\text{N}}{\text{m}^2}$$

$$\phi \geq \sqrt{\frac{4sN_{\max}}{\pi\sigma_R}} = \sqrt{\frac{4 \times 2 \times 1078,7 \times 10^3}{\pi \times 400 \times 10^6}} = 0,083 \text{ m} = 8,3 \text{ cm}$$





**Exercício:** A ponte suspensa da figura abaixo encontra-se sujeita à ação simultânea do peso próprio dos tabuleiros (peso específico:  $\gamma_T = 25 \text{ kN/m}^3$ ; espessura = 40 cm), de uma sobrecarga de  $4 \text{ kN/m}^2$  e do peso próprio das vigas de suporte (40 kN/m). O material dos cabos possui tensão de ruptura  $\sigma_R = 120 \text{ kN/cm}^2$ . Determine as alturas  $y_C$  e  $y_F$  e as forças normais de cada trecho do cabo ACDEFB. Utilizando um coeficiente de segurança  $s=3$ , determine o diâmetro da sua seção transversal uniforme. Desconsidere o peso dos cabos e dos tirantes.

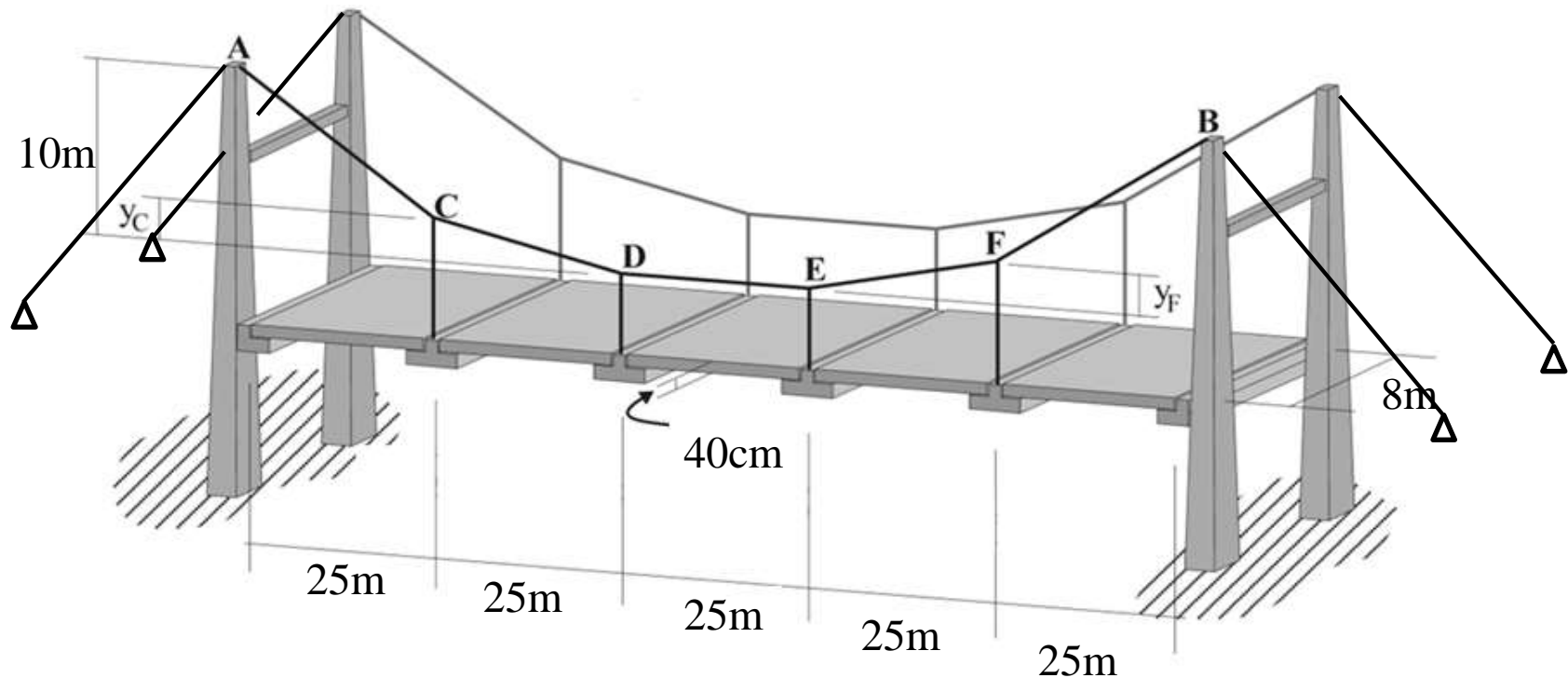

Resolução:

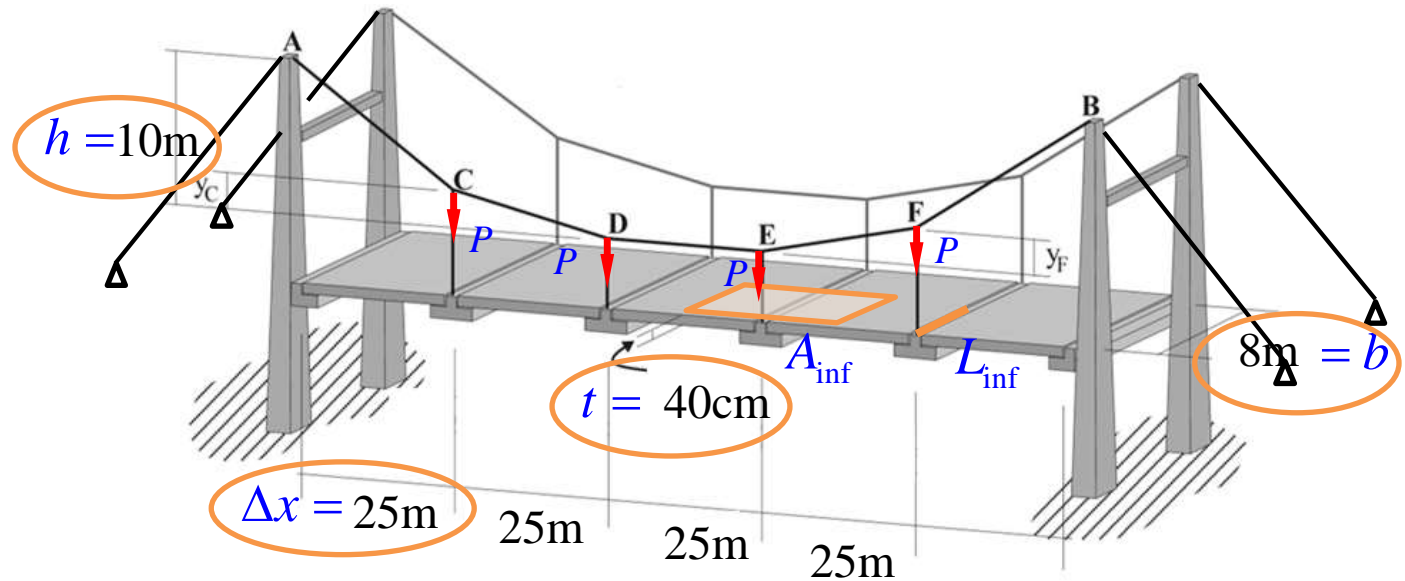

Largura da ponte:  $b = 8m$       Espessura do tabuleiro  $t = 0.4m$

Área de influência de cada tirante:  $A_{inf} = \Delta x \times \frac{b}{2} = 100 m^2$

Largura de influência de cada tirante:  $L_{inf} = \frac{b}{2} = 4 m$

Carga de peso próprio do tabuleiro:  $w_{pp} = \gamma_T \times t = 25 \frac{kN}{m^3} \times 0.4 m = 10 \frac{kN}{m^2}$

Sobrecarga:  $w_{ad} = 4 \frac{kN}{m^2}$       Peso das vigas:  $q_v L_{inf} = 40kN / m$

Carga sobre cada tirante:

$$P = (w_{pp} + w_{ad}) A_{inf} + q_v L_{inf} = (10 + 4) \times 100 + 4 \times 40 = 1560kN$$



Resolução:

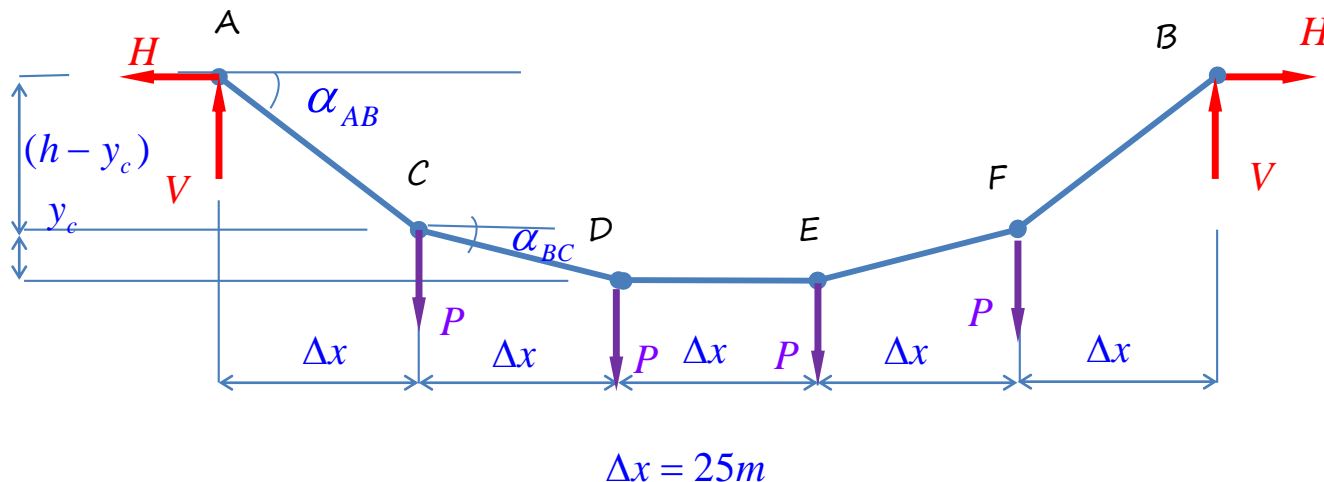

Equilíbrio do cabo ACDEFB:  $V_A = V_B = V = 2P = 3120 \text{ kN}$

Equilíbrio de momentos do trecho ACD em torno do ponto D:

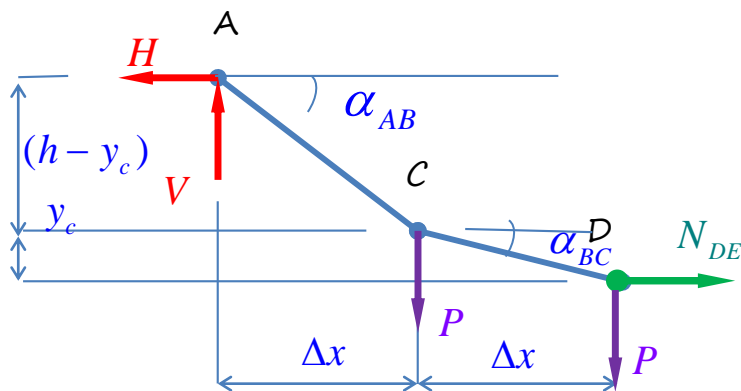

$$H \times h - V \times 2 \times \Delta x + P \times \Delta x = 0$$

$$H = \frac{1}{h} (V \times 2 \times \Delta x - P \times \Delta x) = 11700 \text{ kN}$$



Equilíbrio de momentos do trecho AC em torno do ponto C:

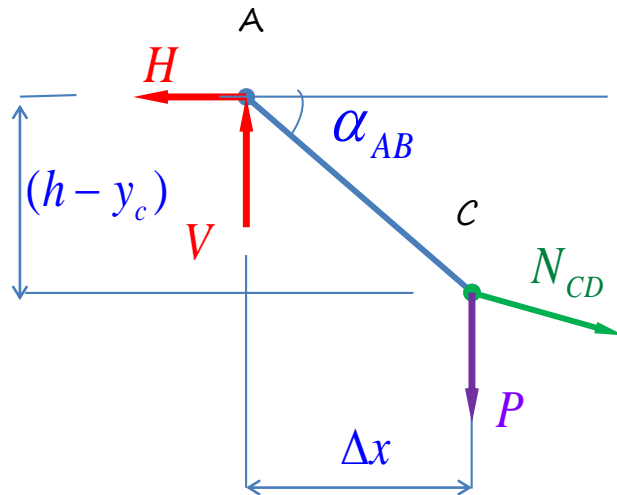

$$H \times (h - y_c) - V \times \Delta x = 0$$

$$y_c = h - \frac{V}{H} \Delta x = 3,33 \text{ m}$$

$$\cos \alpha_{AC} = \frac{\Delta x}{\sqrt{\Delta x^2 + (h - y_c)^2}} = 0,96623 \quad \therefore N_{AC} = \frac{H}{\cos \alpha_{AC}} = \frac{10620}{0,96623} = 12109 \text{ kN}$$

$$\cos \alpha_{CD} = \frac{\Delta x}{\sqrt{\Delta x^2 + (y_c)^2}} = 0,99123 \quad \therefore N_{CD} = \frac{H}{\cos \alpha_{CD}} = \frac{10620}{0,99123} = 11804 \text{ kN}$$

$$\cos \alpha_{DE} = 1 \quad \therefore N_{DE} = \frac{H}{\cos \alpha_{DE}} = H = 11700 \text{ kN}$$



Dimensionamento do cabo ACDEFB:

$$N_{\max} = N_{AC} = 12109 \text{ kN}$$

Resistência à tração:

$$\sigma_{\max} = \frac{N_{\max}}{A_{\text{cabo}}} \leq \frac{\sigma_R}{S} \quad \dots \quad \frac{N_{\max}}{\left(\frac{\pi\phi^2}{4}\right)} \leq \frac{\sigma_R}{S}$$

$$\phi \geq \sqrt{\frac{4SN_{\max}}{\pi\sigma_R}}$$

$$\sigma_R = 120 \frac{\text{kN}}{\text{cm}^2} = 1200 \text{ MPa}$$

$$\phi \geq \sqrt{\frac{4 \times 3 \times 12109 \times 10^3}{\pi \times 1200 \times 10^6}} = 0,19633 \text{ m}$$

Diâmetro do cabo:

$$\phi \equiv 20\text{cm}$$



ARCOS: estruturas planas lineares, sujeitas predominantemente à esforços de compressão.

Forma do arco: preferencialmente funicular (livre de flexão) para os carregamentos permanentes.

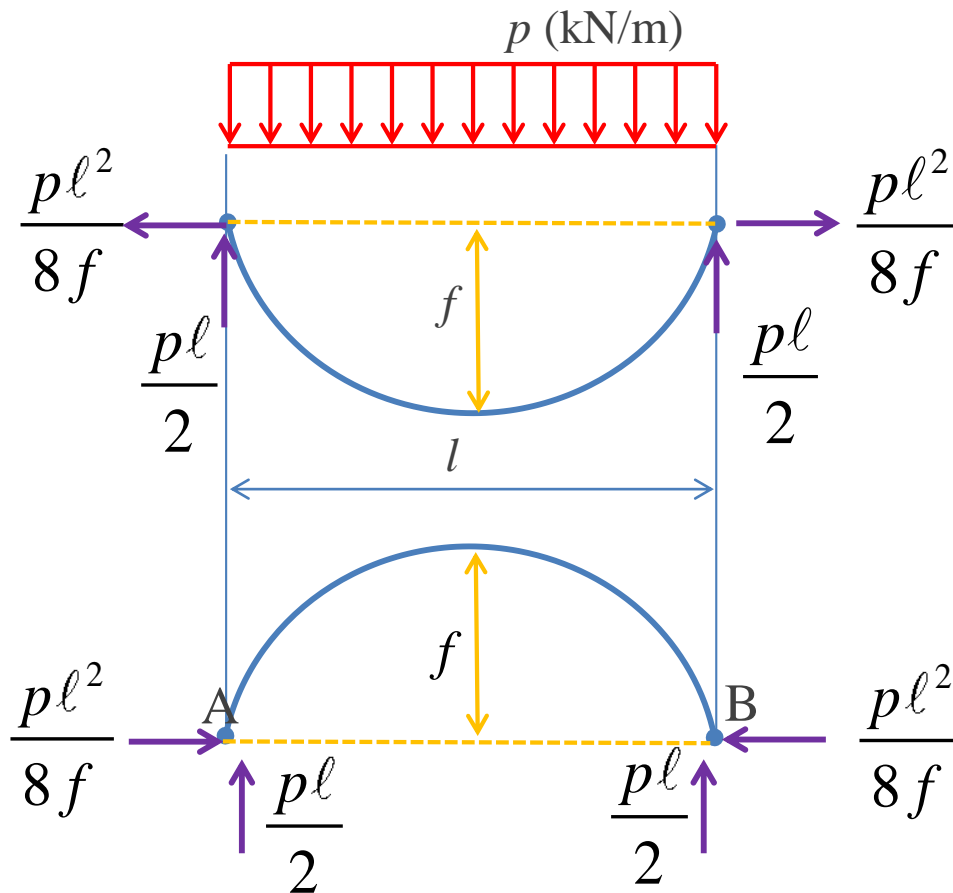

❖ Para ser estável à compressão, o arco deve ter rigidez à flexão, mesmo no caso de não ser solicitado deste modo.





*Viaducto del Ulla, 2011. 630 metros de comprimento, altura máxima 117m, vão principal 168m.*



❖ A rigidez à flexão torna o arco bi-articulado: 1x hiperestático

❖ Como vamos estudar, arcos funiculares para um dado carregamento, podem introduzir articulações internas!

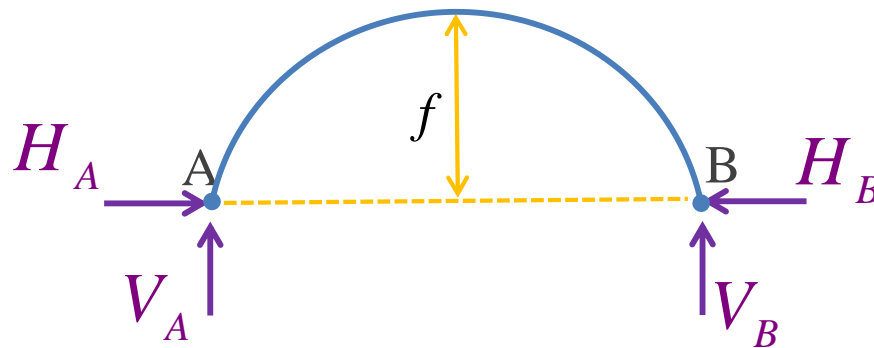



## Etapas:

1. Definir a forma e esforços no arco para os carregamentos permanentes ( $p$ )
2. Inserir uma articulação interna
3. Determinar solicitações para carga accidental ( $q$ )
4. Adicionar as solicitações ( $p + q$ )

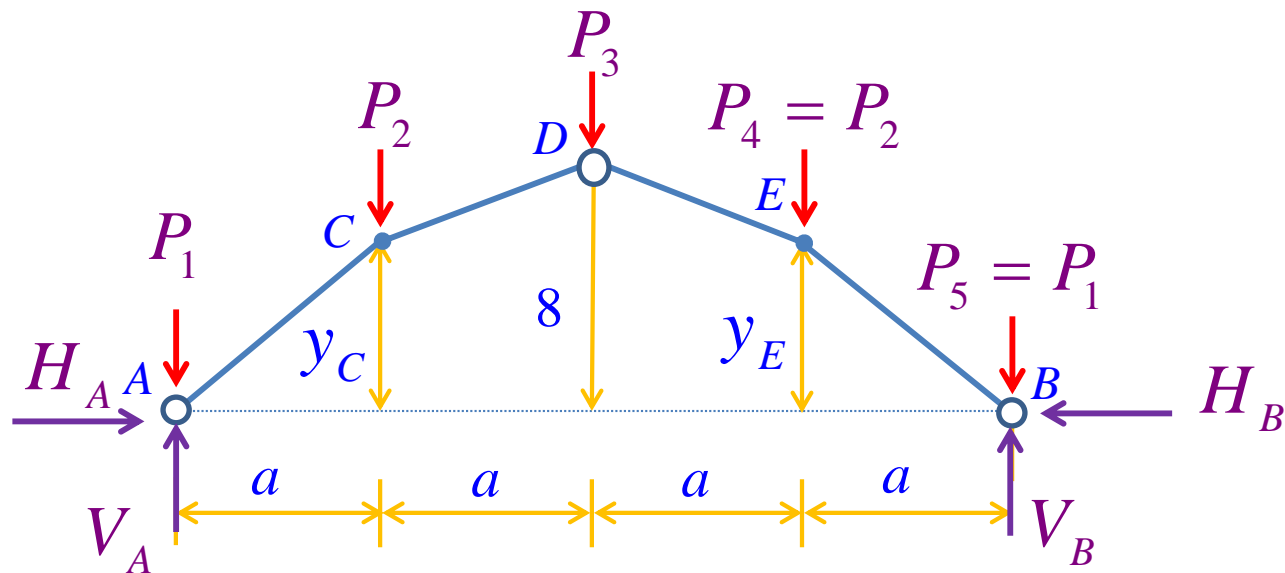

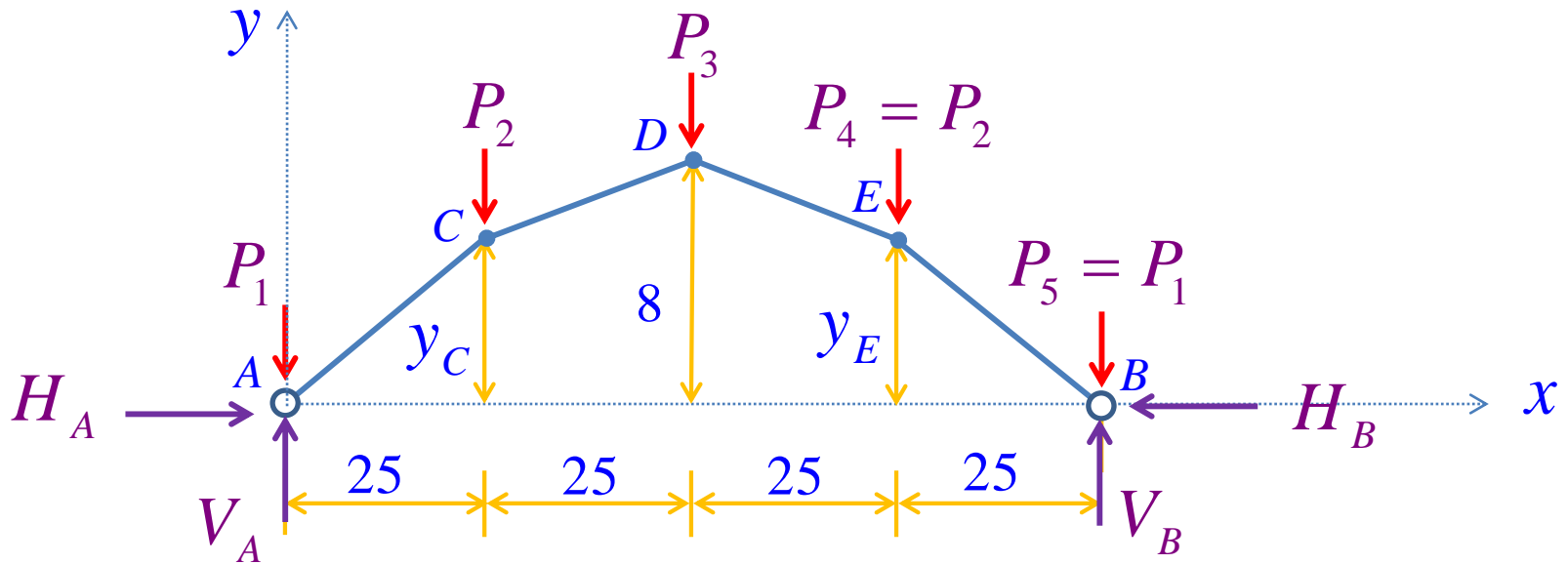

Simetria dos carregamentos permanentes:

$$H_A = H_B$$

$$V_A = V_B$$

$$y_C = y_E$$

É necessário definir apenas uma variável geométrica!



## Exemplo 1:

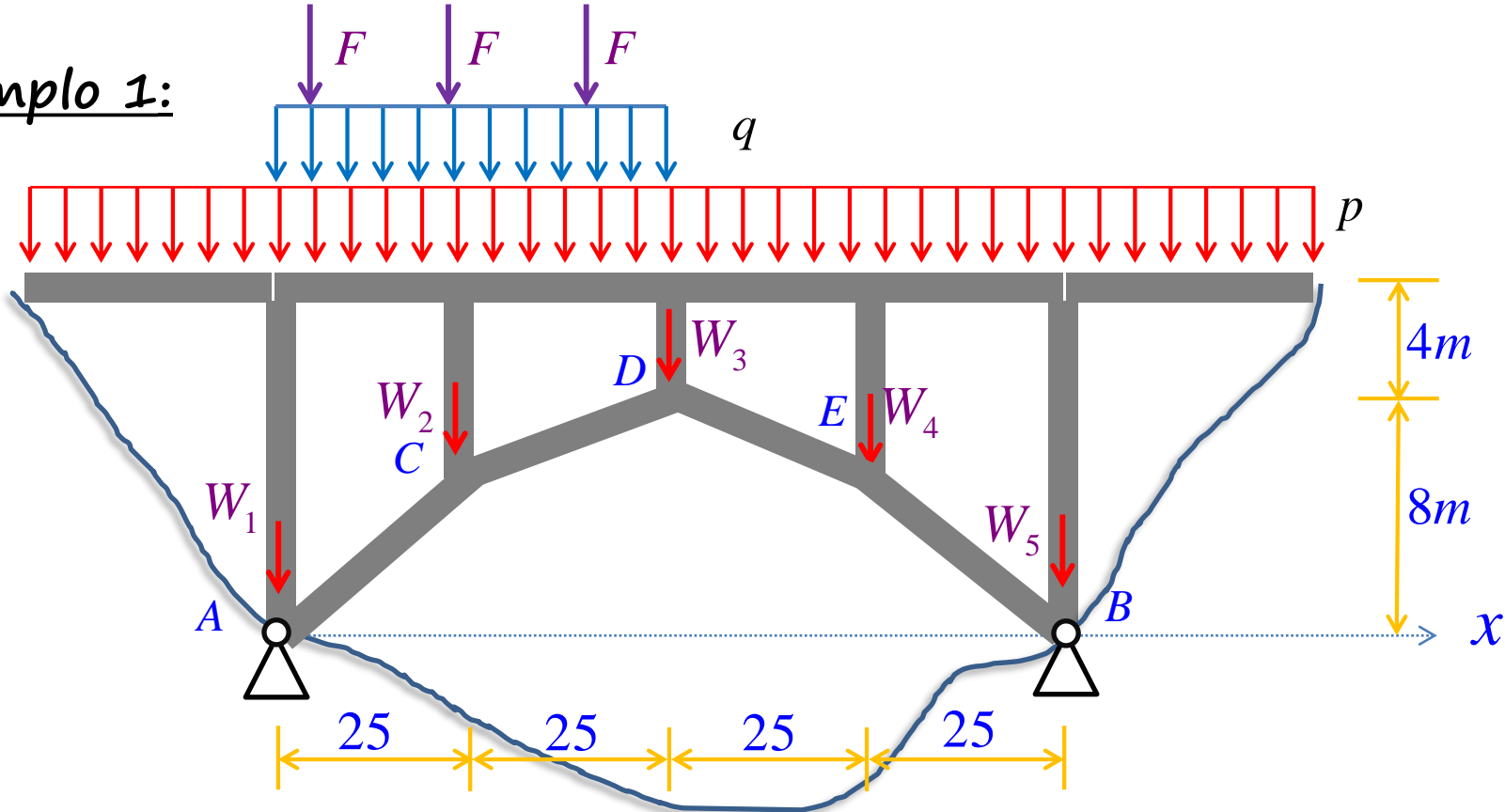

### Cargas permanentes:

$$p = 100 \text{ kN} / \text{m}$$

$$W_1 = W_5 = 100 \text{ kN}$$

$$W_2 = W_4 = 60 \text{ kN}$$

$$W_3 = 40 \text{ kN}$$

### Cargas móveis:

$$q = 20 \text{ kN} / \text{m}$$

$$F = 100 \text{ kN}$$



Definição das cargas permanentes nos nós do arco:  $P_i = p \cdot l_i + W_i$

$$P_1 = P_5 = 100 \times 25 + 100 = 2600 \text{ kN}$$

$$P_2 = P_4 = 100 \times 25 + 60 = 2560 \text{ kN}$$

$$P_3 = 100 \times 25 + 40 = 2540 \text{ kN}$$

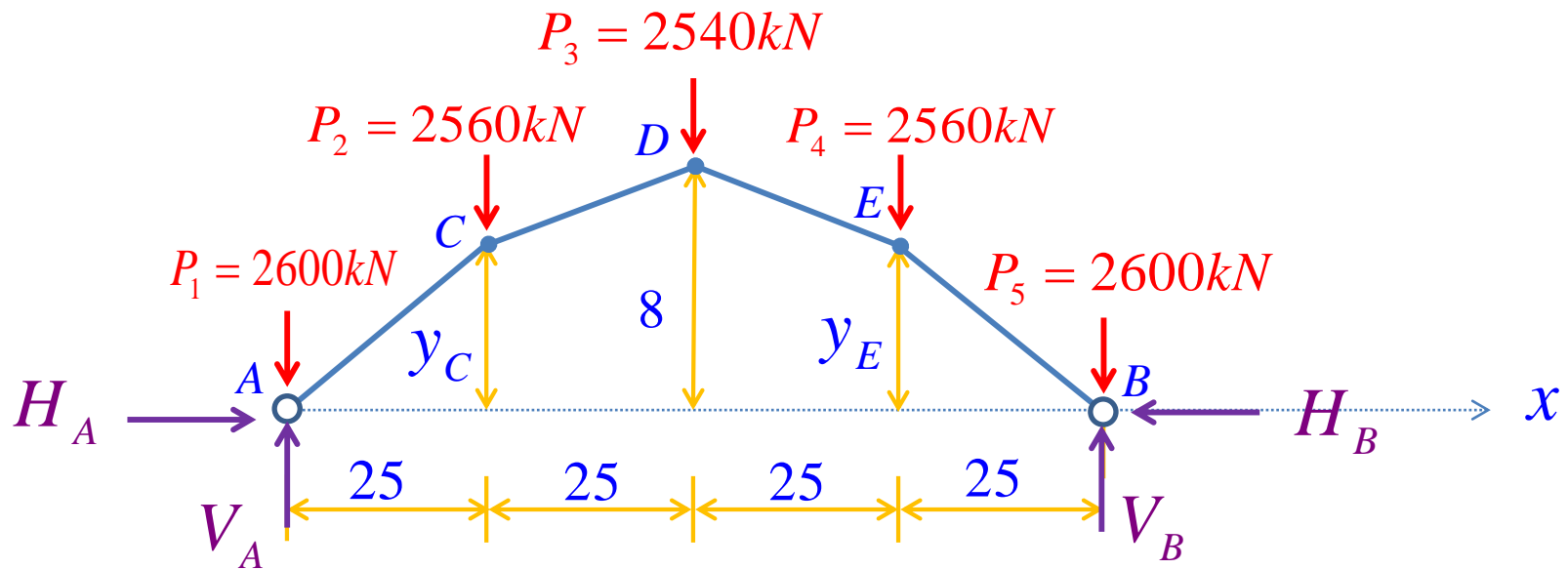

## Equilíbrio:

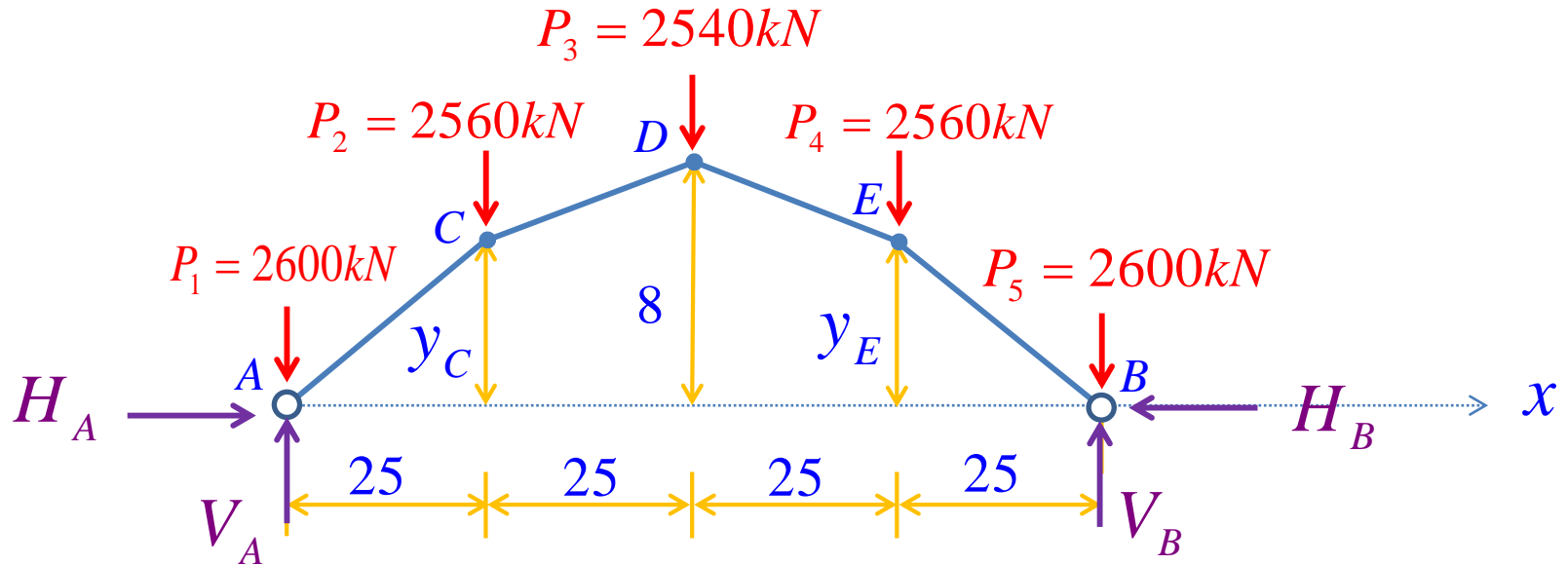

$$\sum F_X = 0 \quad H_A = H_B = 0 \quad \therefore \quad H_A = H_B$$

$$\sum F_Y = 0 \quad V_A + V_B - 2 \times 2600 - 2 \times 2560 - 2540 = 0$$

$$V_A = V_B = 6430\text{kN}$$

SIMETRIA!!



Empuxo: Supondo que o arco seja funicular às cargas permanentes:

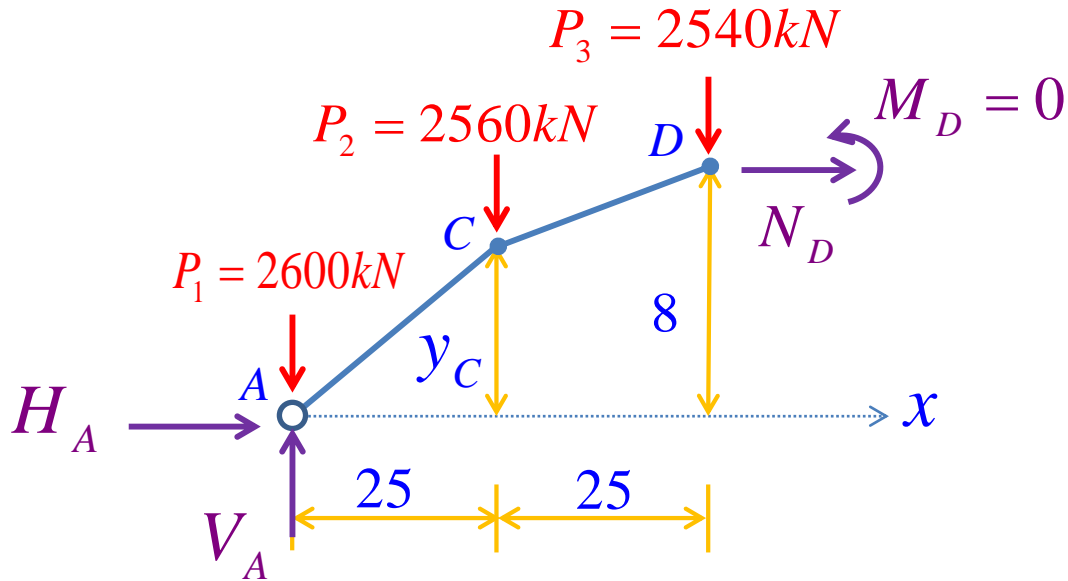

Equilíbrio do trecho AD, à esquerda:

$$\sum M_{(D)} = H_A \times 8 - (V_A - 2600) \times 50 + 2560 \times 25 + M_D = 0$$

$$H_A = \frac{1}{8} [(6430 - 2600)50 - 2560 \times 25]$$

$$H_A = 15.937,5 \text{ kN} = H_B$$



## Determinação da ordenada $y_C$

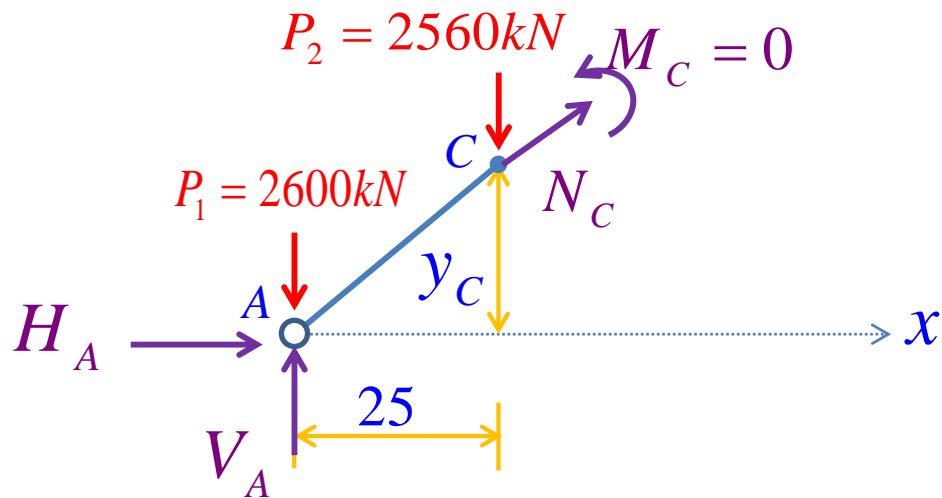

Para cargas permanentes:

$$\sum M_{(C)} = 0$$

Equilíbrio do trecho AC, à esquerda:

$$\sum M_{(C)} = M_C + 15.937,5 \times y_C - (6430 - 2600) \times 25 = 0$$

$$y_C = \frac{(6430 - 2600) 25}{15.937,5}$$

$$y_C = 6,01m = y_E$$



## Determinação na força normal nos segmentos do arco

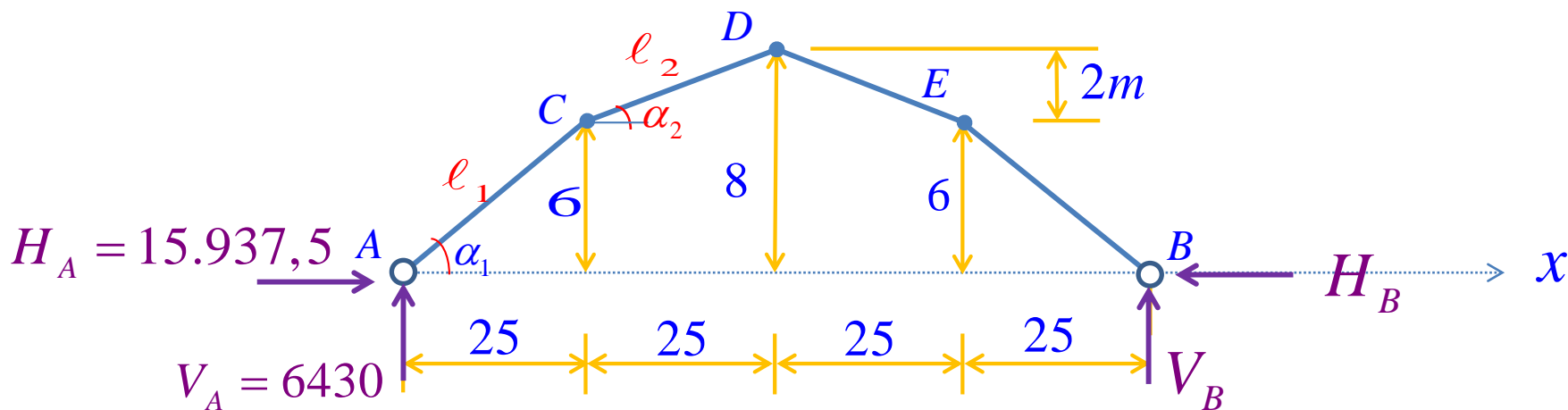

$i$	$\Delta x_i$ (m)	$\Delta y_i$ (m)	$L_i$ (m)	$\cos \alpha_i$	$N_i = H / \cos \alpha_i$ (kN)
1	25	6	25,71	0,972	-16.396,6
2	25	2	25,08	0,997	-15.985,4





Para carregamentos acidentais, para os quais o arco não é funicular, este fica sujeito à flexão.

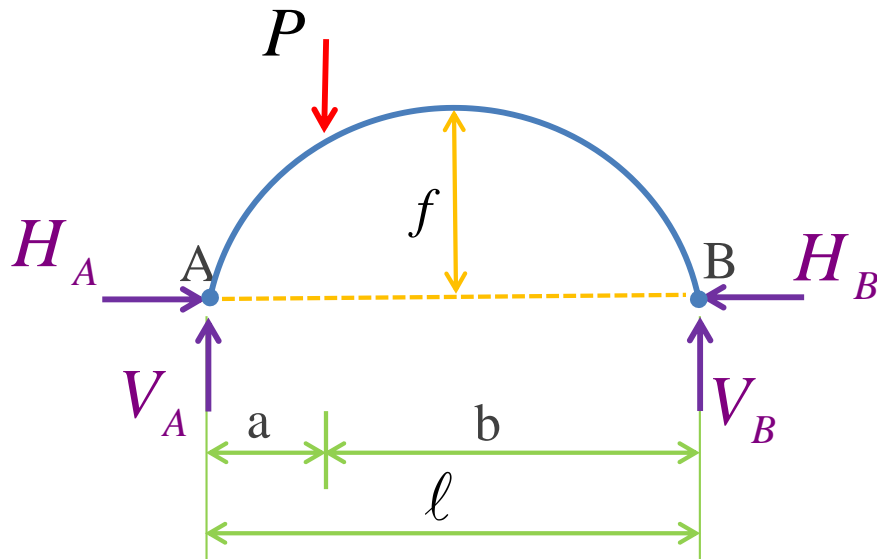

$$\sum F_X = 0$$

?

$$H_A - H_B = 0 \quad \therefore H_A = H_B$$

$$\sum F_Y = 0$$

$$V_A + V_B - P = 0$$

$$\sum M_{(A)} = 0 \quad V_B \times l - P \times a = 0 \quad V_B = \frac{P \times a}{l}$$

$$V_A = \frac{P \times b}{l}$$

Estrutura 1 x HIPERESTÁTICA



Introduzindo uma articulação interna: ARCO TRIARTICULADO

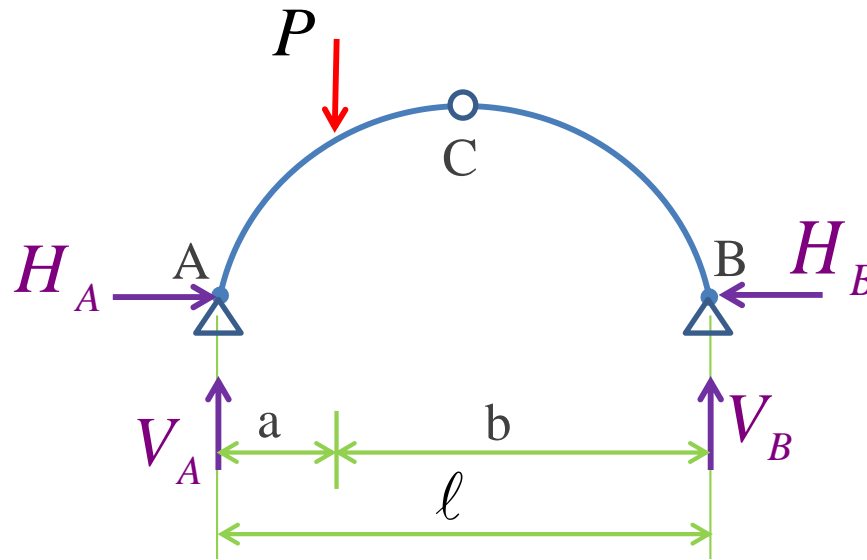

ISOSTÁTICO

Dispõe-se de mais uma equação

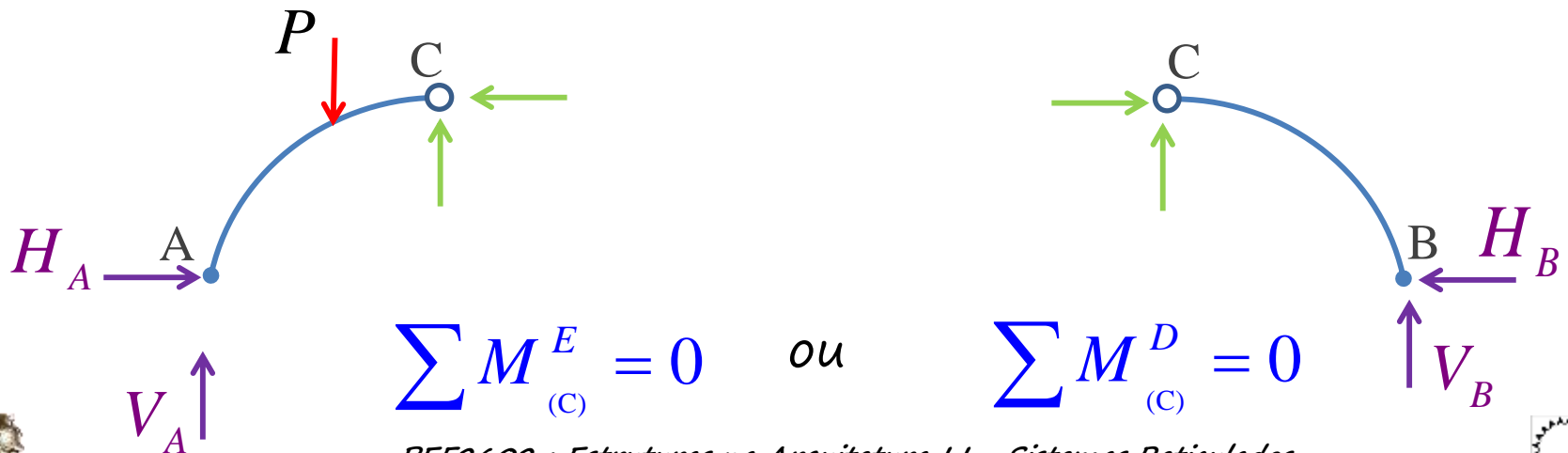

$$\sum M_{(C)}^E = 0 \quad \text{ou} \quad \sum M_{(C)}^D = 0$$



Cargas acidentais:

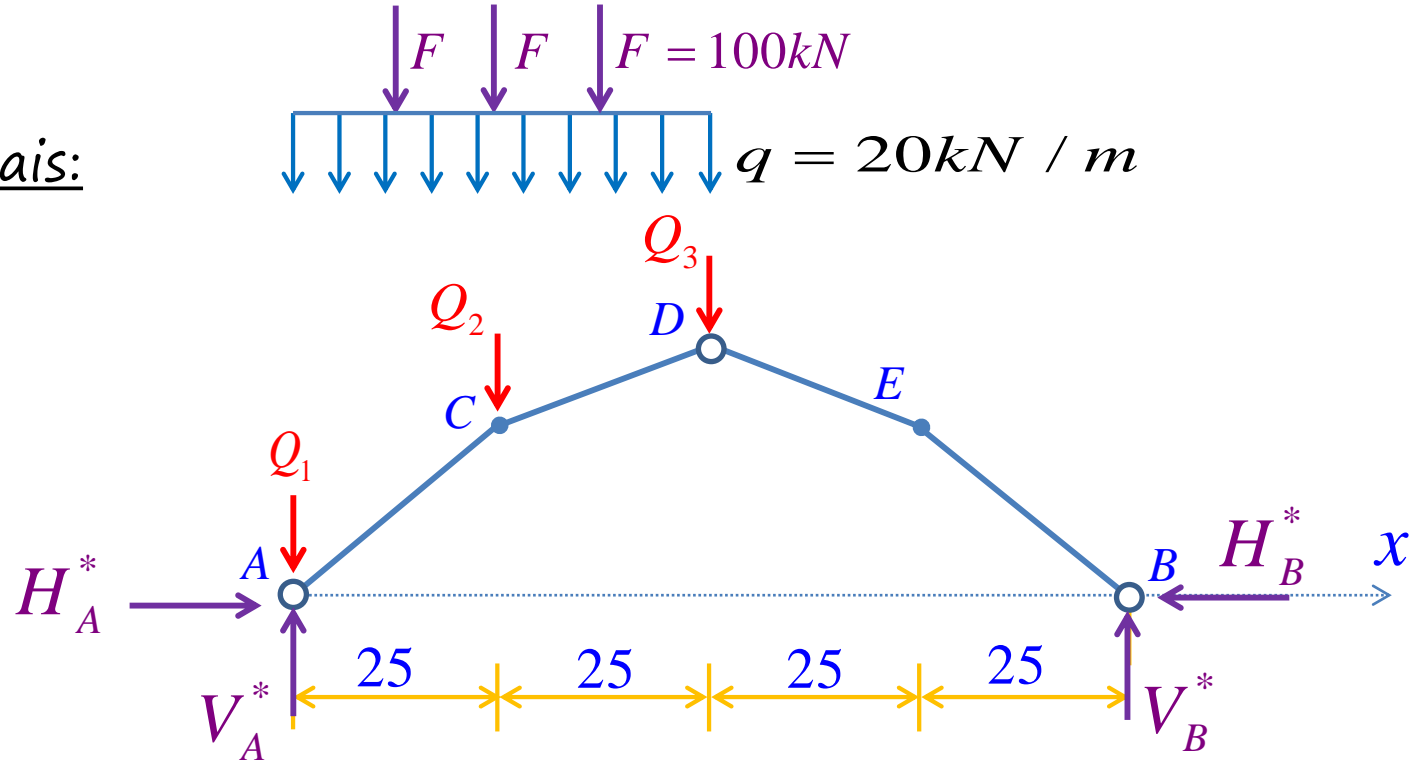

$$Q_1 = \frac{20 \times 25}{2} + \frac{100}{2} = 300 \text{ kN}$$

$$Q_2 = 20 \times 25 + 2 \times \frac{100}{2} + 100 = 700 \text{ kN}$$

$$Q_3 = 300 \text{ kN}$$



## Cargas acidentais:

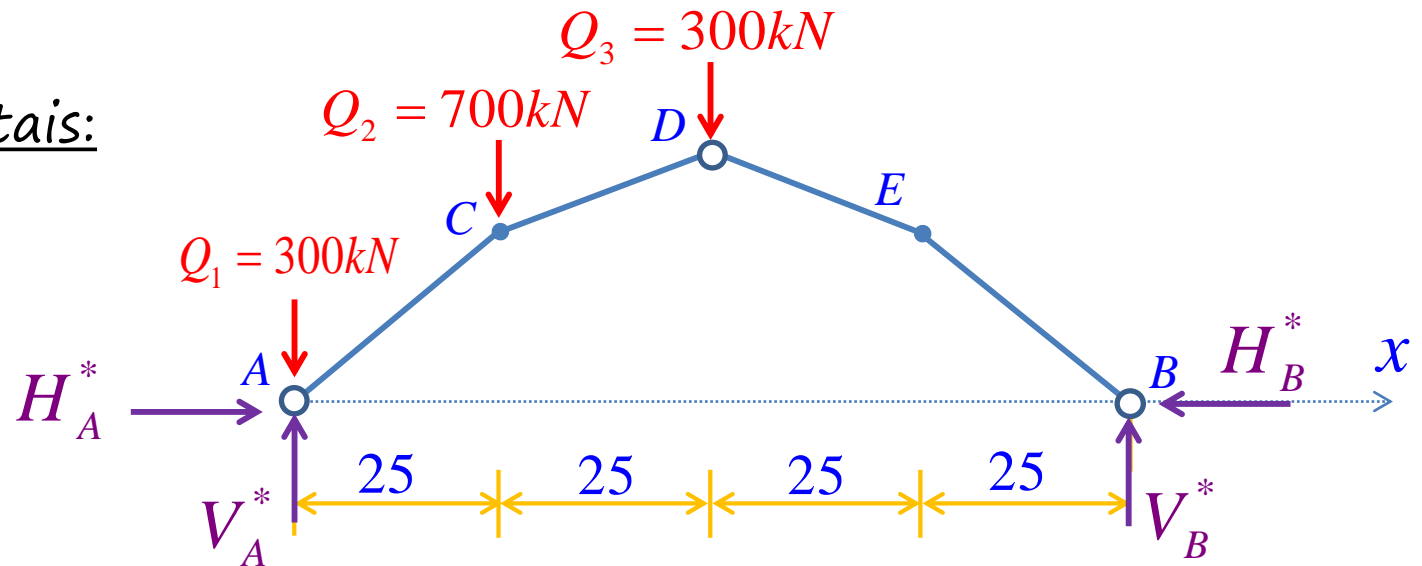

$$\sum F_X = H_A^* - H_B^* = 0 \quad \therefore H_A^* = H_B^*$$

$$\sum F_Y = V_A^* + V_B^* - Q_1 - Q_2 - Q_3 = 0 \quad \therefore V_A^* + V_B^* = 1300 \text{ kN}$$

$$\sum M_{(A)} = 100 \times V_B^* - 25 \times Q_2 - 50 \times Q_3 = 0 \quad \therefore V_B^* = \frac{25 \times 700 + 50 \times 300}{100}$$

$$V_B^* = 325 \text{ kN} \quad \therefore V_A^* = 975 \text{ kN}$$

$$\sum M_{(D)} = 50 \times V_B^* - 8 \times H_B^* = 0 \quad \therefore H_B^* = \frac{25 \times 325}{8}$$

$$H_B^* = H_A^* = 2031,25 \text{ kN}$$



Cortando em "C":

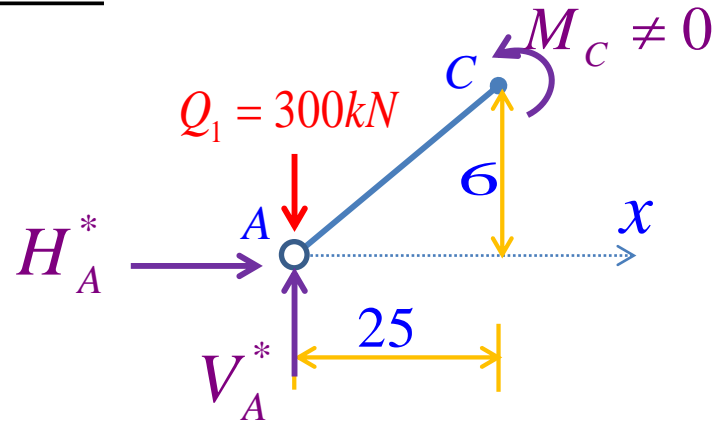

$$\sum M_{(C)}^E = M_C + (Q_1 - V_A^*) \times 25 - 6 \times H_A^* = 0$$

$$M_C = (Q_1 - V_A^*) \times 25 - 6 \times H_A^*$$

$$M_C = (975 - 300) \times 25 - 6 \times 2031,25$$

$$M_C = 4.687,5 \text{ kN} \cdot \text{m}$$



Cortando em "E":

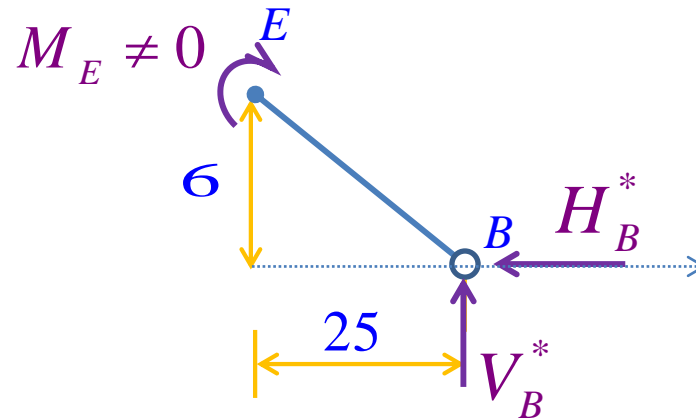

$$\sum M_{(E)}^D = -M_E + V_B^* \times 25 - 6 \times H_B^* = 0$$

$$M_E = V_B^* \times 25 - 6 \times H_B^*$$

$$M_E = 325 \times 25 - 6 \times 2031,25$$

$$M_E = -4.062,5 \text{ kN} \cdot \text{m}$$



## Diagrama de momentos fletores:

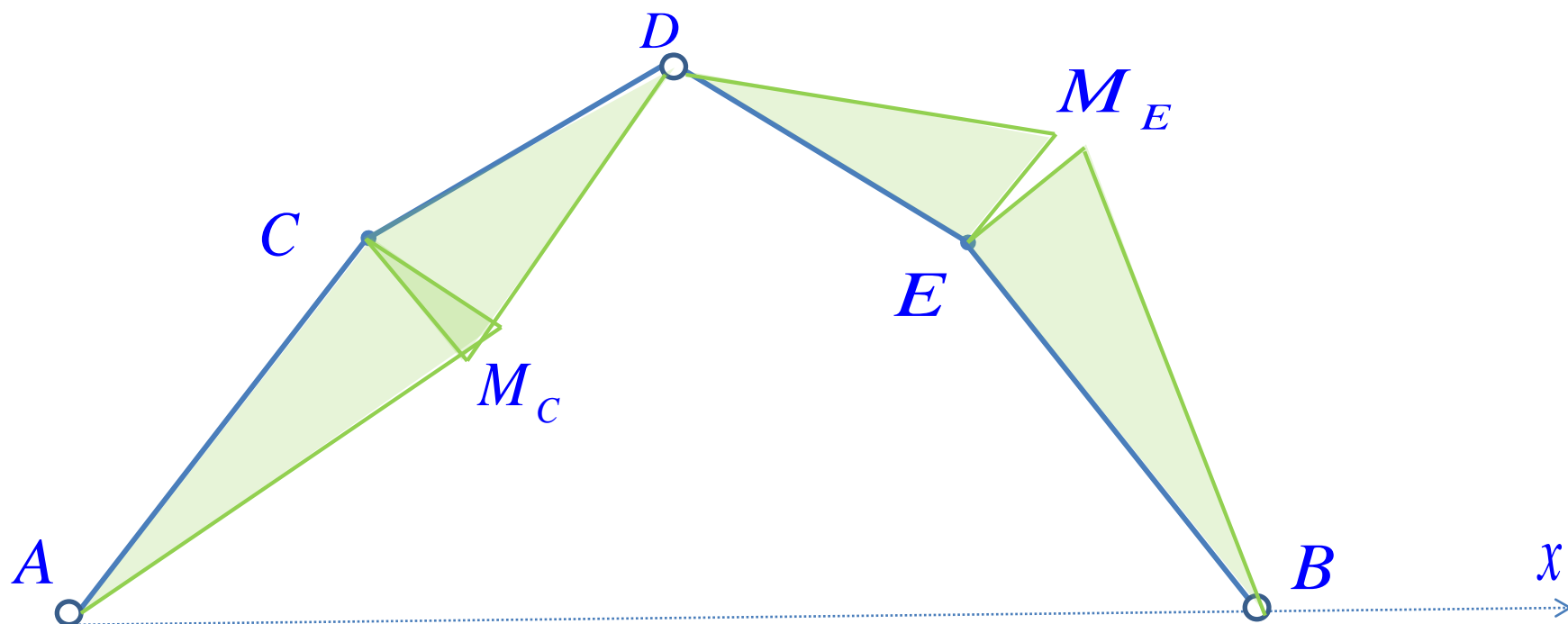

- ❖ Analogamente, podem ser traçados os diagramas de  $N$  e  $Q$ .
- ❖ As solicitações para o carregamento total (permanente + accidental) são obtidos por superposição.



**Exemplo 2:** A ponte suspensa da figura abaixo encontra-se sujeita à ação simultânea do peso próprio do tabuleiro ( $\gamma_T = 25 \text{ kN/m}^3$ ; espessura = 50 cm), de uma sobrecarga de  $5 \text{ kN/m}^2$  e do peso próprio das vigas de suporte ( $10 \text{ kN/m}$ ). O arco de sustentação é formado pelas barras AC, CD, DE e EB, cujo material possui tensão de ruptura à compressão  $\sigma_{R, \text{compr}} = 4 \text{ kN/cm}^2$ . Por sua vez, os tirantes possuem material com tensão de ruptura  $\sigma_{R, \text{tração}} = 40 \text{ kN/cm}^2$ . Utilizando um coeficiente de segurança  $s=2$ , determine as forças normais das barras que formam o arco, as forças normais dos tirantes, a dimensão das seções transversais e as alturas  $y_C$  e  $y_E$  (o peso do arco e dos tirantes não é considerado).

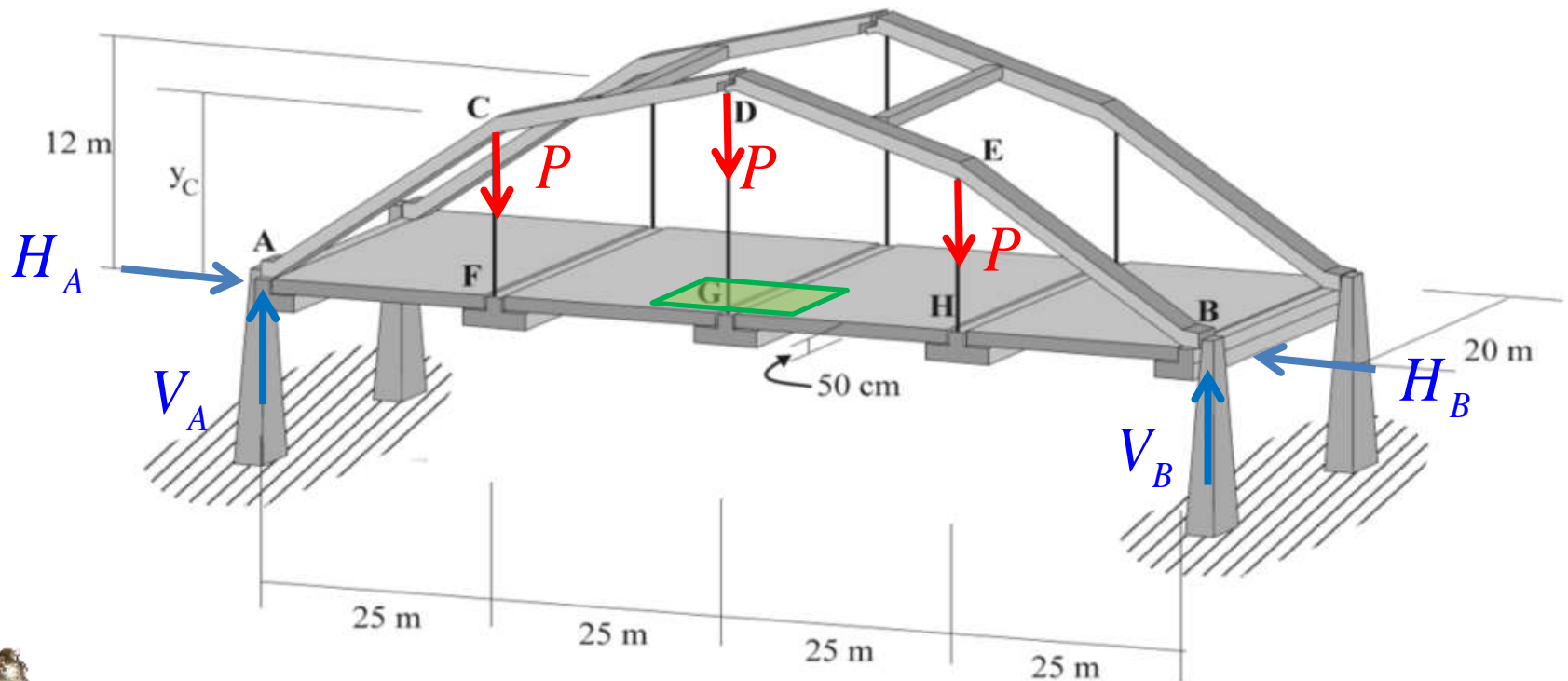



## Determinação das cargas equivalentes:

$$P = (\gamma_T \times \text{vol}_{\text{influência Tab}}) + (\text{Sob} \times A_{\text{influência}}) + \text{Reação da viga}$$

$$P = (25 \times 25 \times 10 \times 0,5) + (5 \times 25 \times 10) + (10 \times 10) = 4475 \text{ kN}$$

## Reações de apoio:

$$\sum F_X = 0 \quad H_A - H_B = 0 \quad \therefore H_A = H_B$$

$$\sum F_Y = 0 \quad V_A + V_B - 3 \times P = 0 \quad V_A = V_B = \frac{3 \times P}{2} = 6712,5 \text{ kN}$$



Cortando em "D":

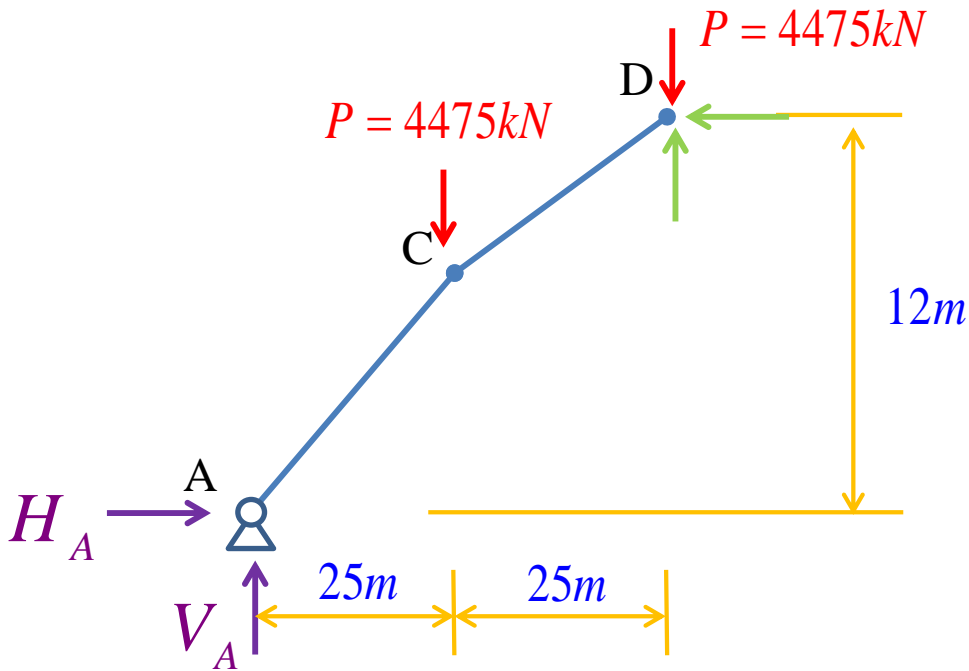

$$\sum M_{(D)}^E = V_A \times 50 - H_A \times 12 - P \times 25 = 0$$

$$H_A = \frac{P \times 25 - V_A \times 50}{12} = 18.645,83kN$$

Cortando em "C":

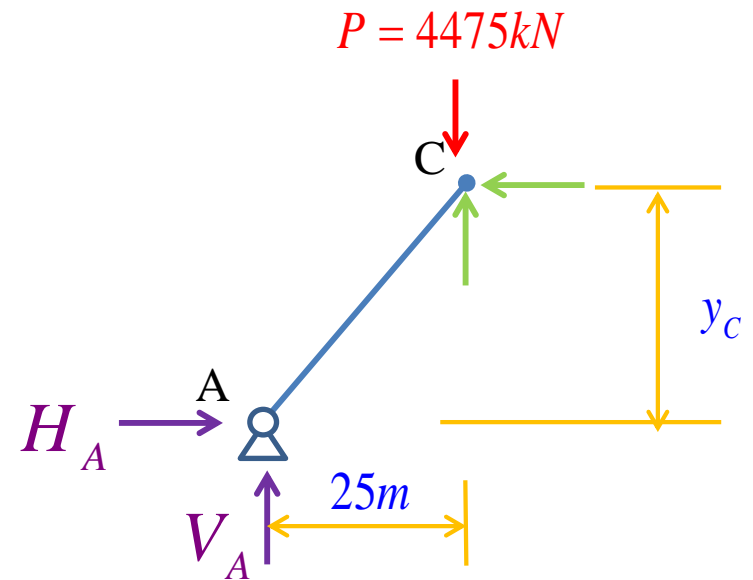

$$\sum M_{(C)}^E = V_A \times 25 - H_A \times y_C = 0$$

$$y_C = \frac{V_A \times 25}{H_A} = 9m$$



Equilíbrio do Nó A:

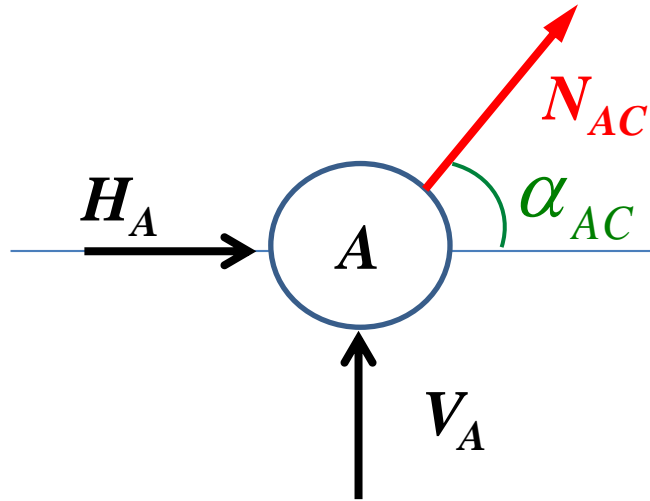

$$\cos \alpha_{AC} = \frac{25}{\sqrt{25^2 + 9^2}} = 0,9409$$

$$N_{AC} = \frac{-H_A}{\cos \alpha_{AC}} = -19.816,8kN$$

Equilíbrio do Nó C:

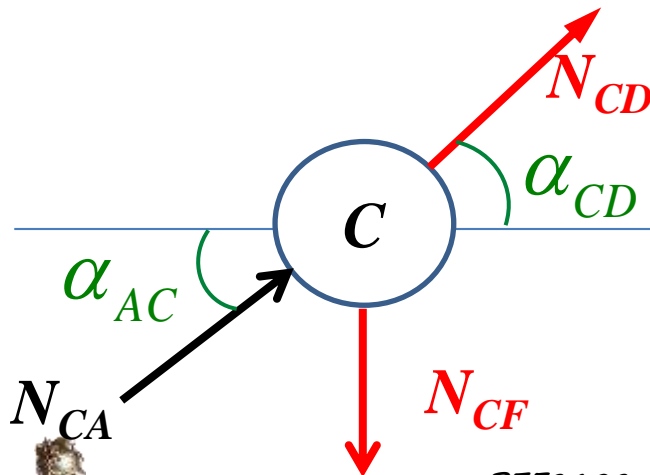

$$\cos \alpha_{CD} = \frac{25}{\sqrt{25^2 + (12-9)^2}} = 0,993$$

$$N_{CD} = \frac{-H_A}{\cos \alpha_{CD}} = -18.777,27kN$$

$$\sum F_Y = 0 \quad N_{CF} + N_{CD} \times \text{sen} \alpha_{CD} - N_{CA} \times \text{sen} \alpha_{CA} = 0$$

$$N_{CF} = -18.777,27 \times \frac{3}{\sqrt{25^2 + 3^2}} + 19.816,8 \times \frac{9}{\sqrt{25^2 + 9^2}}$$

$$N_{CF} = 4475kN$$



## Equilíbrio do Nó D:

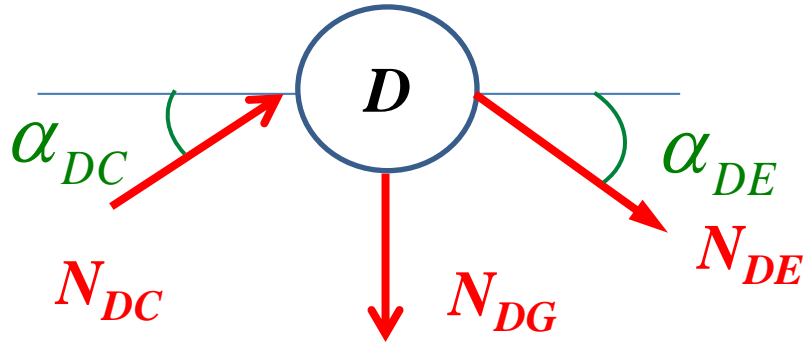

$$\sum F_Y = 0$$

$$-N_{DG} - N_{DC} \times \text{sen}\alpha_{DC} - N_{DE} \times \text{sen}\alpha_{DE} = 0$$

$$N_{DG} = -2 \times \left( -18.777,27 \times \frac{3}{\sqrt{25^2 + 3^2}} \right)$$

$$N_{DG} = 4475\text{kN}$$



## Dimensionamento do arco ACDEB e dos tirantes:

Arco – barras comprimidas:

$$\sigma = \frac{N}{A_{nec}} \leq \frac{\sigma_{R,compress\~ao}}{S}$$

$$\frac{19.816,8}{A_{AC}} \leq \frac{4}{2}$$

$$A_{AC} \geq 9908,4cm^2$$

$$\frac{18.777,27}{A_{CD}} \leq \frac{4}{2}$$

$$A_{CD} \geq 9388,63cm^2$$

Tirantes – barras tracionadas:

$$\sigma = \frac{N}{A_{nec}} \leq \frac{\sigma_{R,tra\~cao}}{S}$$

$$\frac{4475}{A} \leq \frac{40}{2}$$

$$A \geq 223,75cm^2$$



**Exemplo 3:** O arco da figura encontra-se sujeito à ação do peso próprio  $q$  do tabuleiro e de cargas verticais  $P$  aplicadas nos pontos D e E. Determine as reações de apoio, as forças normais de cada barra do arco e a altura  $y_1$ .

$P=30\text{kN}$  e  $q=75\text{kN/m}$

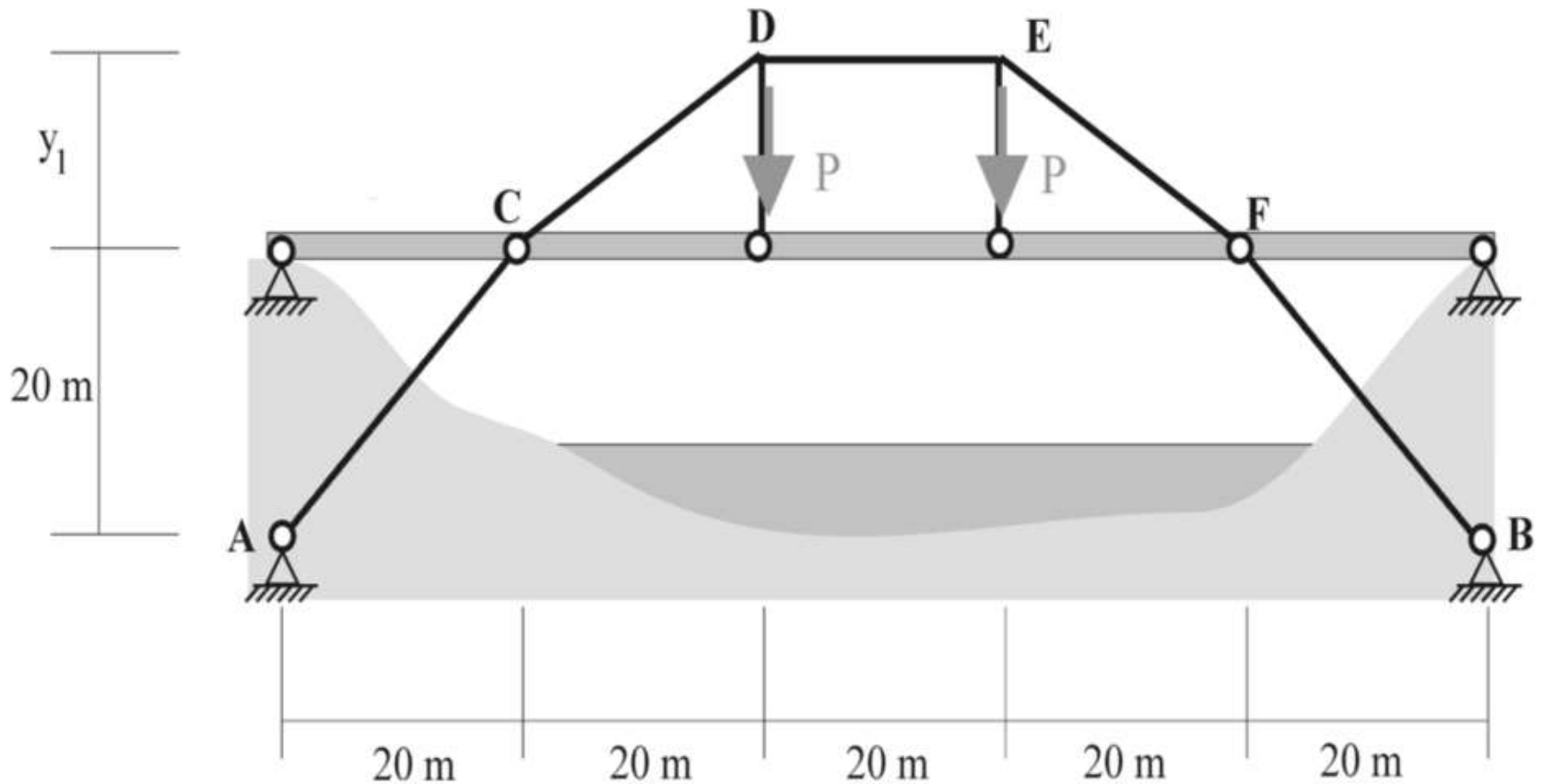

## Determinação das cargas equivalentes:

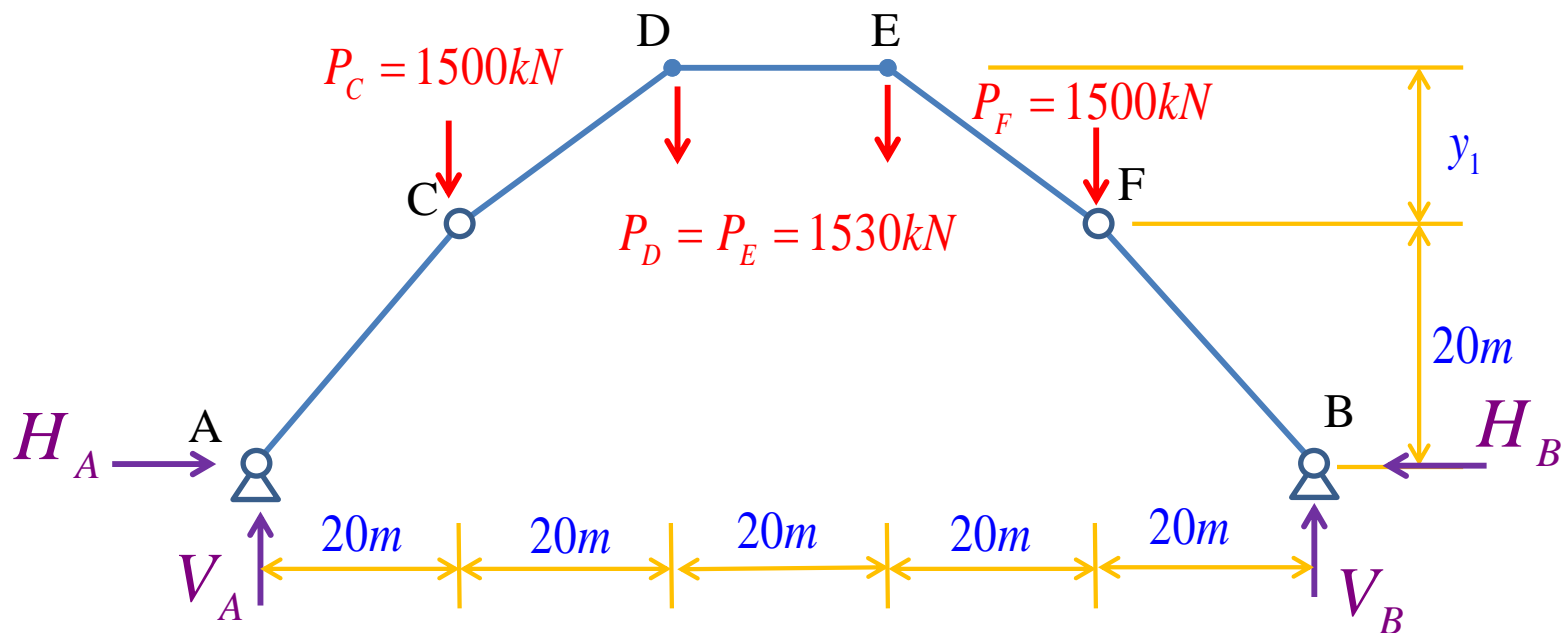

$$P_C = P_F = 75 \times 20 = 1500kN$$

$$P_D = P_E = 1500 + 30 = 1530kN$$



## Determinação reações de apoio:

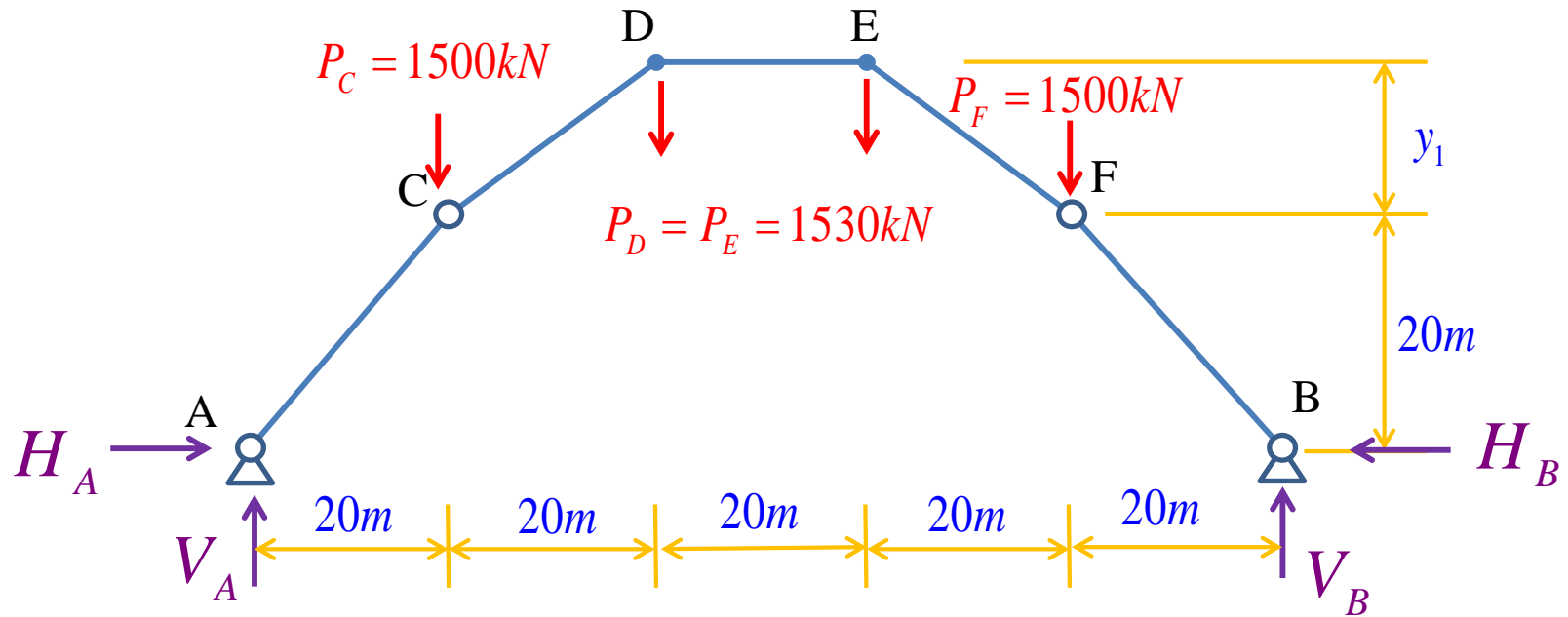

$$\sum F_X = 0 \quad H_A = H_B = 0 \quad \therefore \quad H_A = H_B$$

$$\sum F_Y = 0 \quad V_A + V_B - 2 \times 1500 - 2 \times 1530 = 0$$

$$V_A = V_B = 3030kN$$





Cortando em "C":

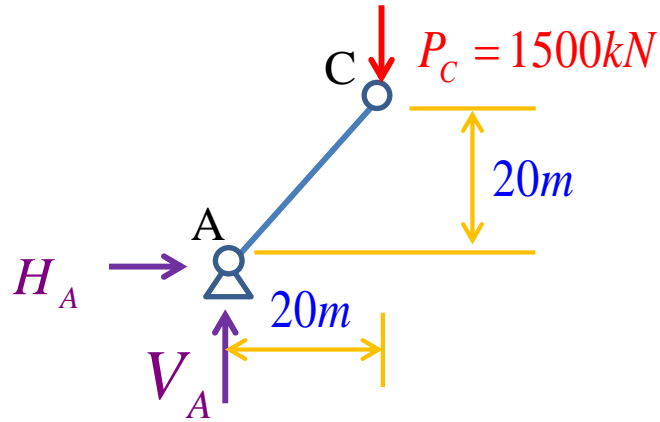

$$\sum M_{(C)}^E = V_A \times 20 - H_A \times 20 = 0$$

$$H_A = V_A = 3030kN = H_B$$

Cortando em "D":

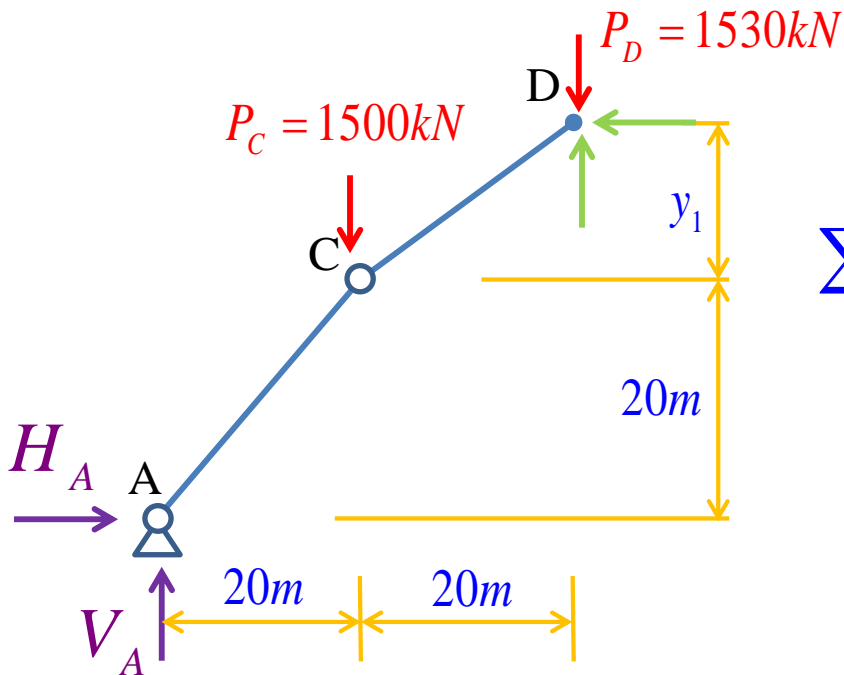

$$\sum M_{(D)}^E = V_A \times 40 - H_A \times (20 + y_1) - 1500 \times 20 = 0$$

$$3030 \times 40 - 3030 \times (20 + y_1) - 1500 \times 20 = 0$$

$$y_1 = \frac{30600}{3030} = 10,099m$$



## Equilíbrio do Nó A:

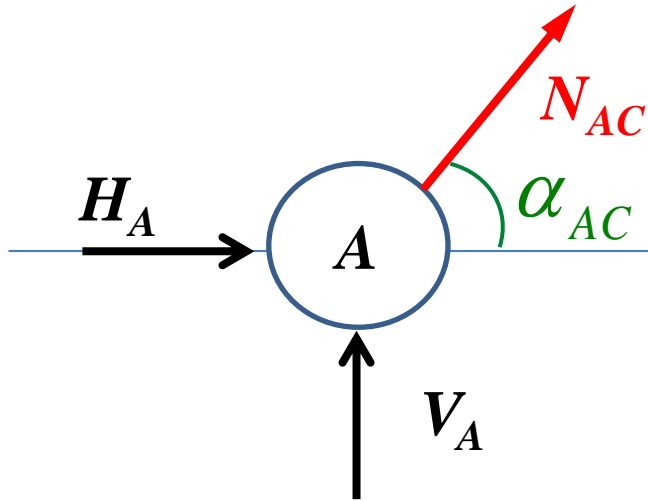

$$\cos \alpha_{AC} = \frac{20}{\sqrt{20^2 + 20^2}} = 0,707$$

$$N_{AC} = \frac{-H_A}{\cos \alpha_{AC}} = -4285,71 \text{ kN}$$

Em geral, para cargas verticais:

$$N_i \cos \alpha_i = H = \text{constante!}$$

Logo, para as forças normais:

$$N_i = \frac{H}{\cos \alpha_i}$$



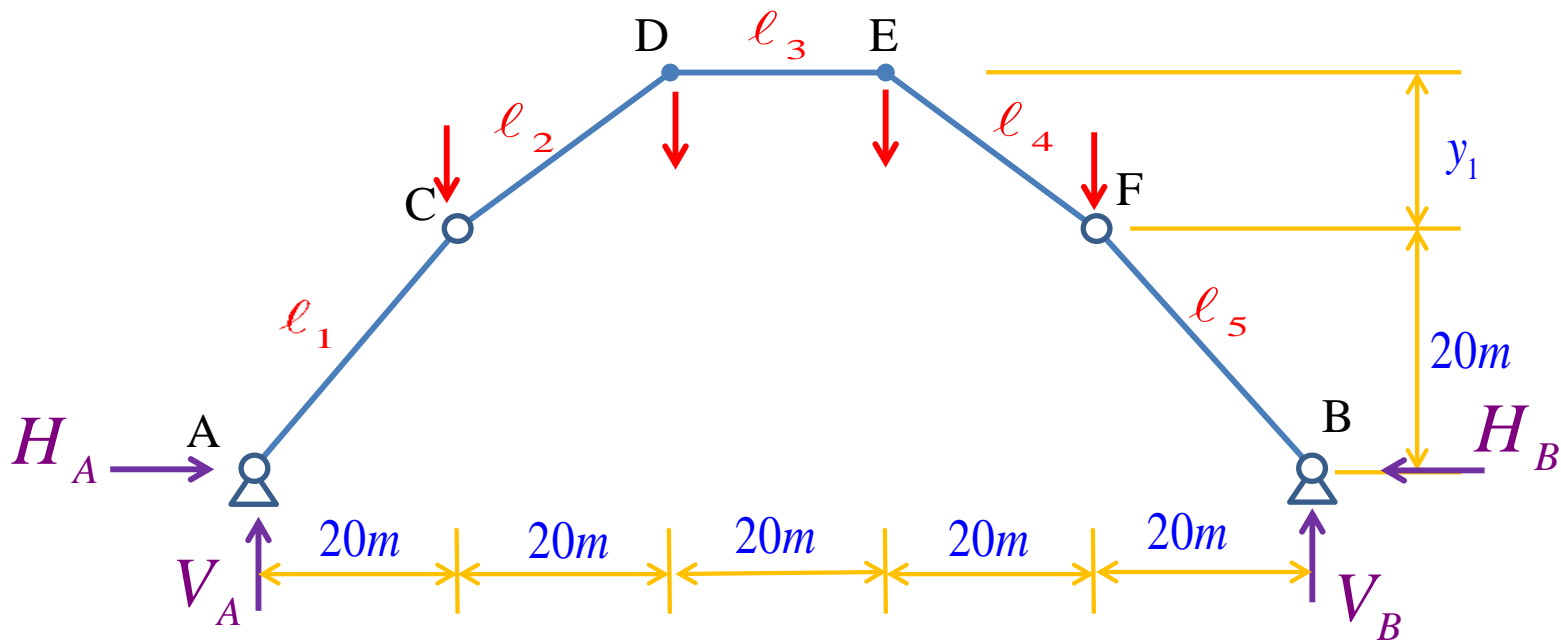

$i$	$\Delta x_i$ (m)	$\Delta y_i$ (m)	$L_i$ (m)	$\cos \alpha_i$	$N_i = -H / \cos \alpha_i$ (kN)
1=5	20,0	20,00	28,28	0,707	-4.285,7
2=4	20,0	10,09	22,40	0,893	-3.393,1
3	20,0	0,00	20,00	1,000	-3.030,0

