

O Impacto da Modelagem Paramétrica no Projeto de Estruturas

Ruy Marcelo de Oliveira Pauletti - Prof. Associado Poli-USP

Isabel Moreira de Oliveira - Mestranda Poli-USP

Márcio Sartorelli Venâncio de Souza - Aluno Poli-USP

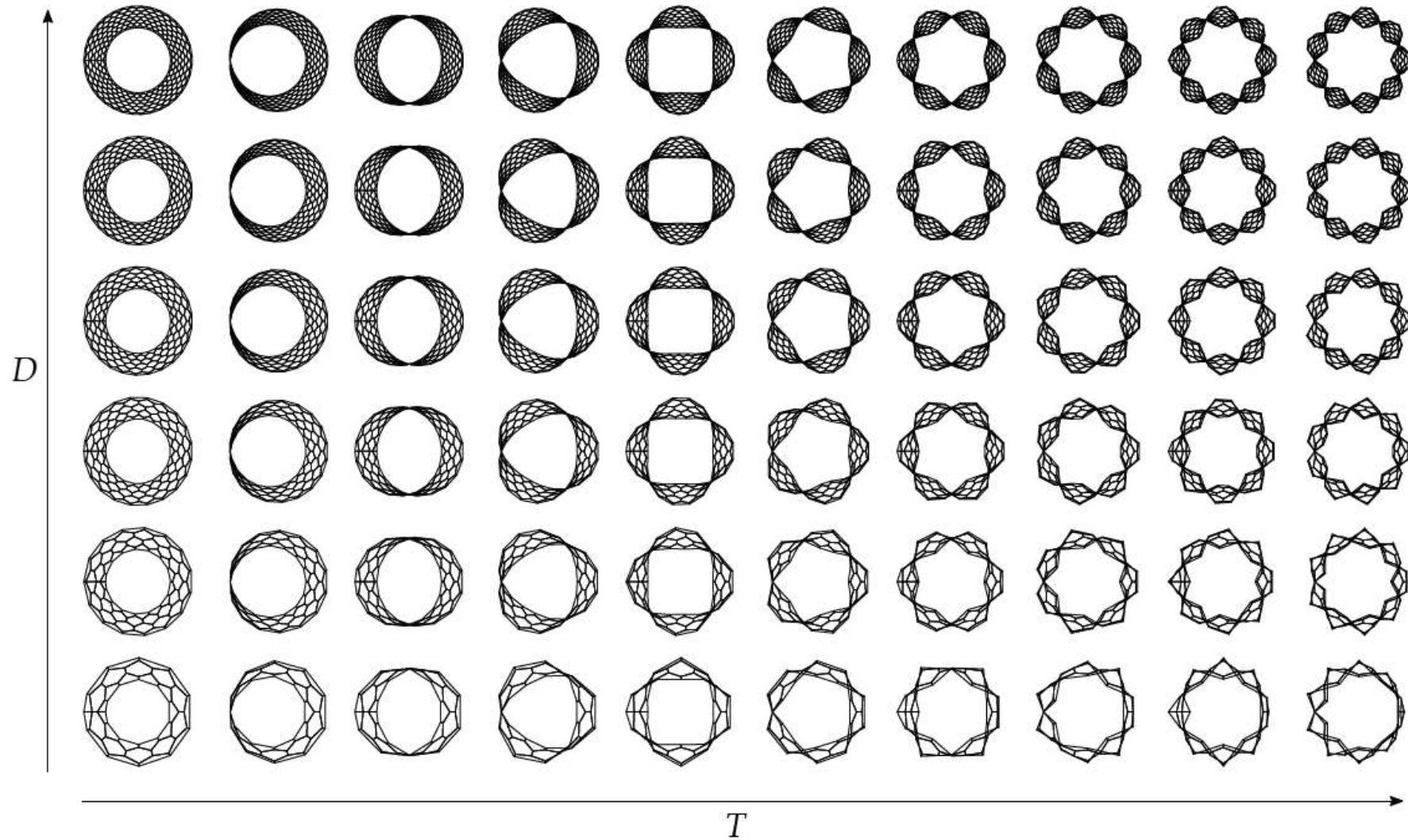
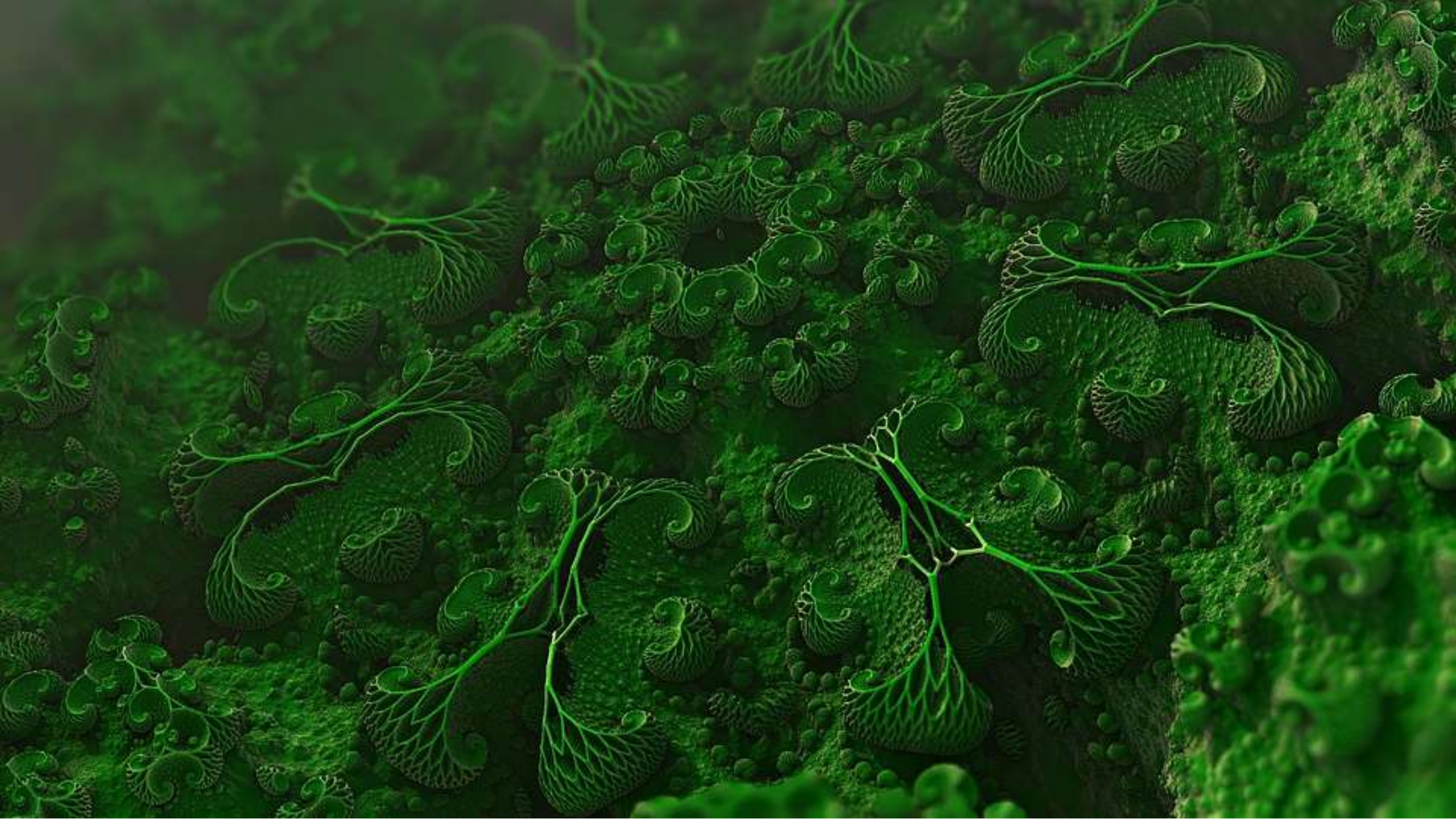

Figure 1. Visualising the design space of a simple parametric model with two parameters.



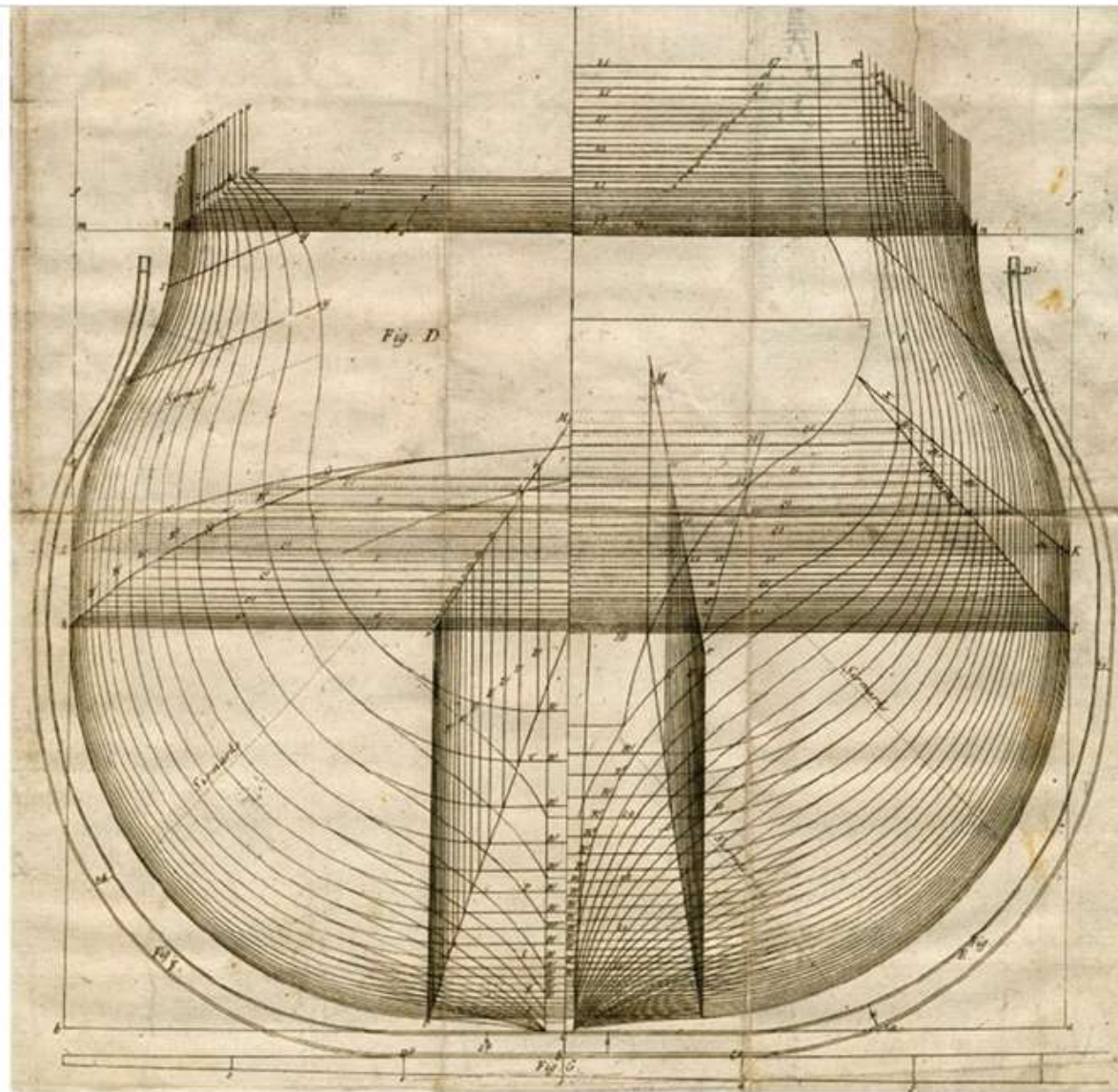
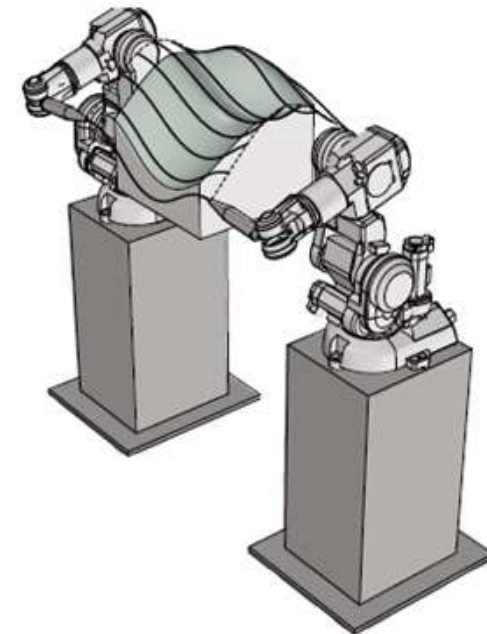
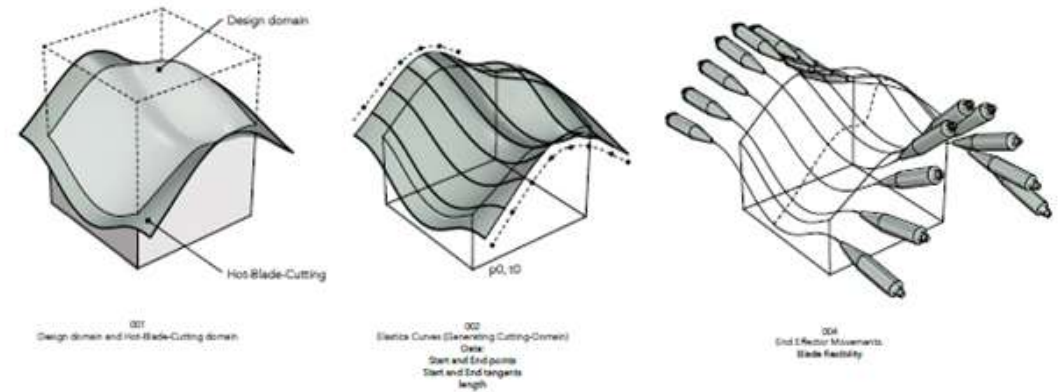

Figure 3. Use of physical splines for ship-hull manufacturing.
 Copyright: William Sutherland, *The Shipbuilders Assistant: or, Some Essays Towards Completing the Art of Marine Architecture* (London, 1711).



Designing for Hot-Blade Cutting

Geometric Approaches for High-Speed Manufacturing of Doubly-Curved Architectural Surfaces

David Brander, Andreas Bærentzen, Kenn Clausen, Ann-Sofie Fisker, Jens Gravesen, Morten N. Lund, Toke B. Nerbjerg, Kasper Steenstrup, and Asbjørn Søndergaard



Figure 23. Examples of the workshop participants design explorations.
Design left: Jill Smith & Phil Dench. Design, right: Dharman Gersch.

Matthias Pliessnig twisting benches, University of Wisconsin (from 2006 on)







Hypar Vault in Troyed, France, 2017
Giuseppe Fallacara, New Fundamentals Research Group, Bari



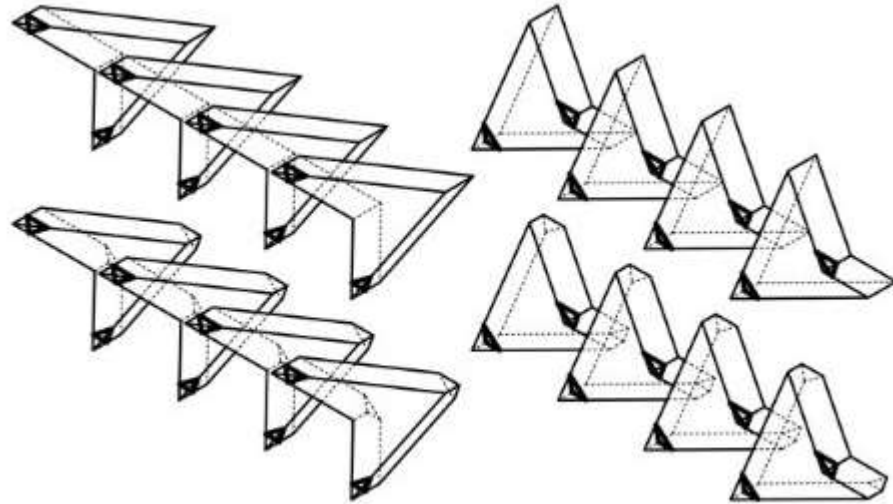
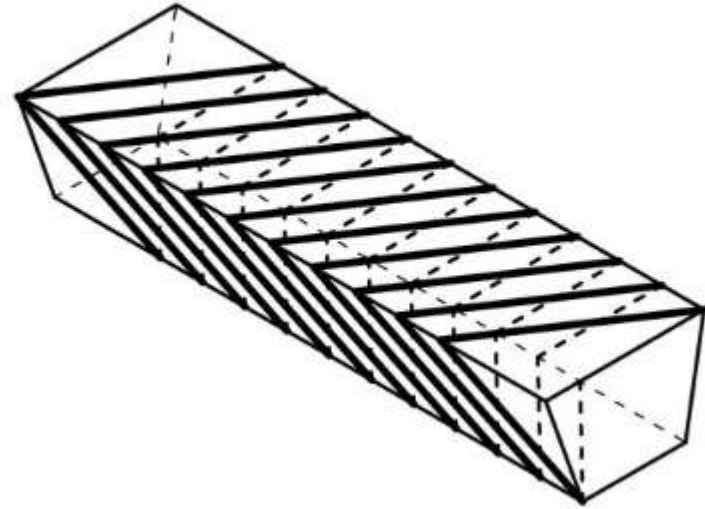
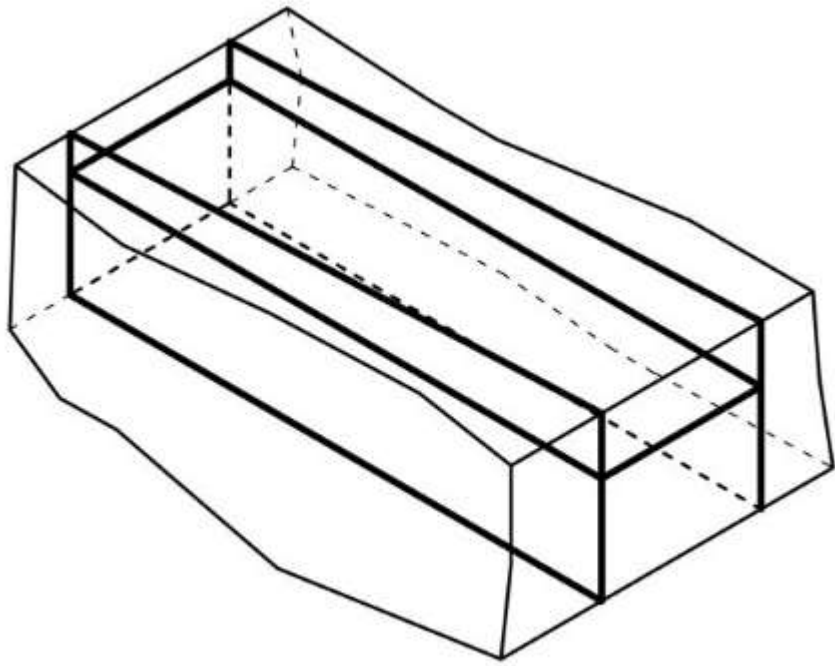

HYPARBOLE , Arch. MARC FORNES /
THEVERYMANY , Providence, USA, 2017



A bending-active membrane sculpture
(Hamburg, 2017)

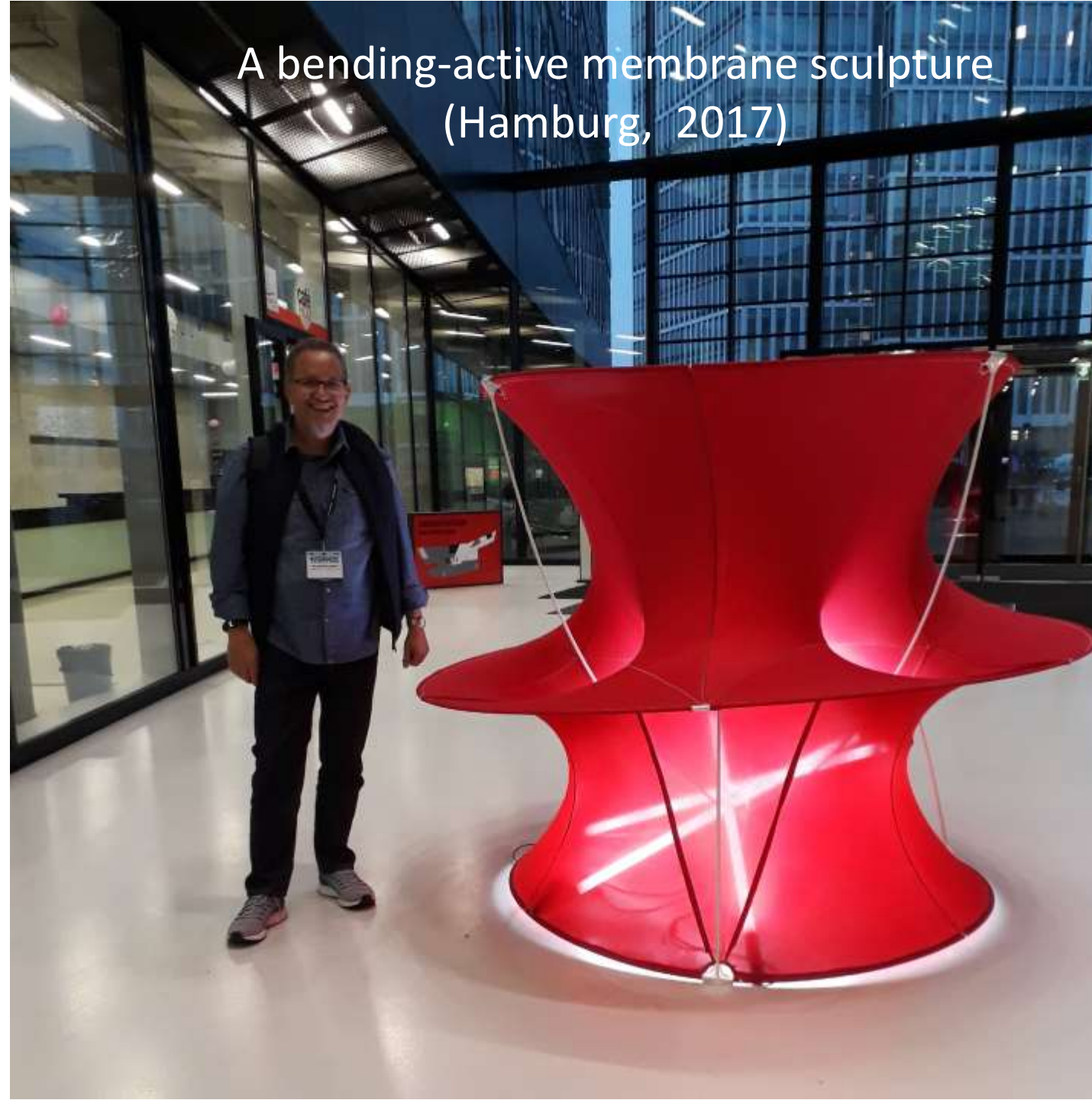

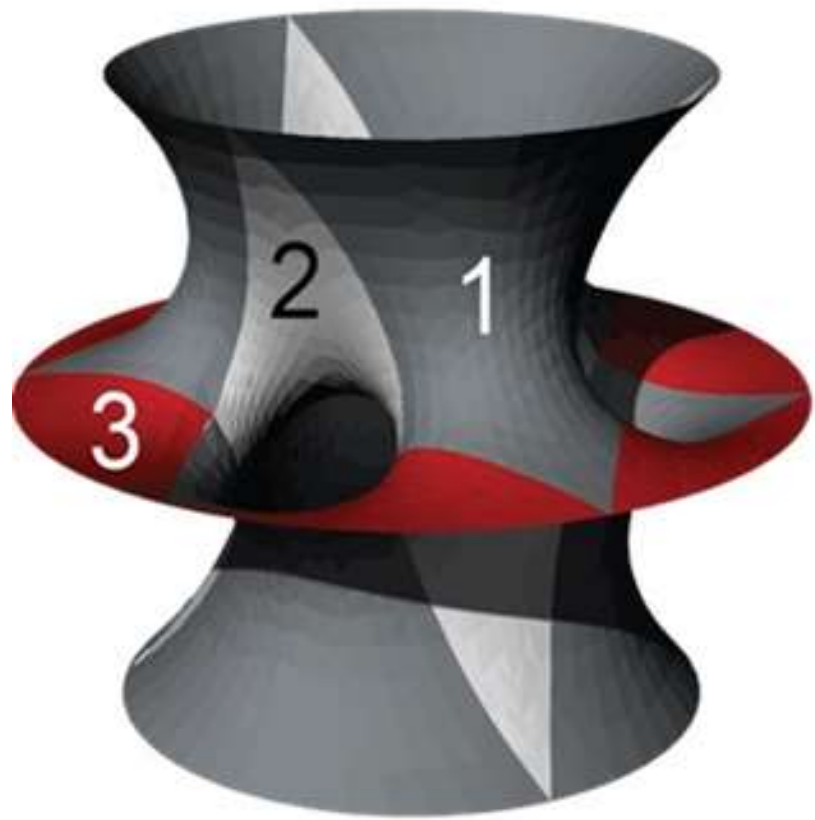

PERSPECTIVE VIEW

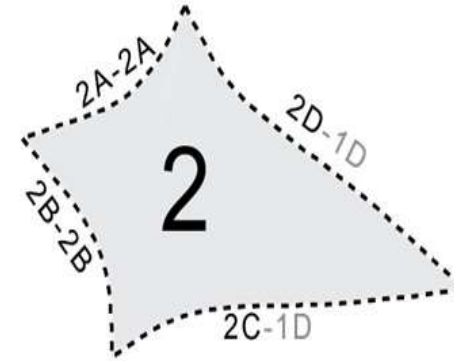
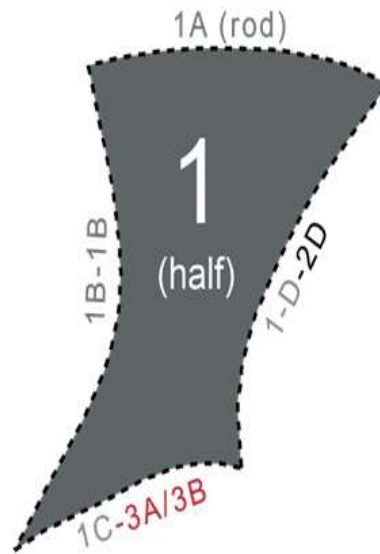

FLATTENED PATTERNS

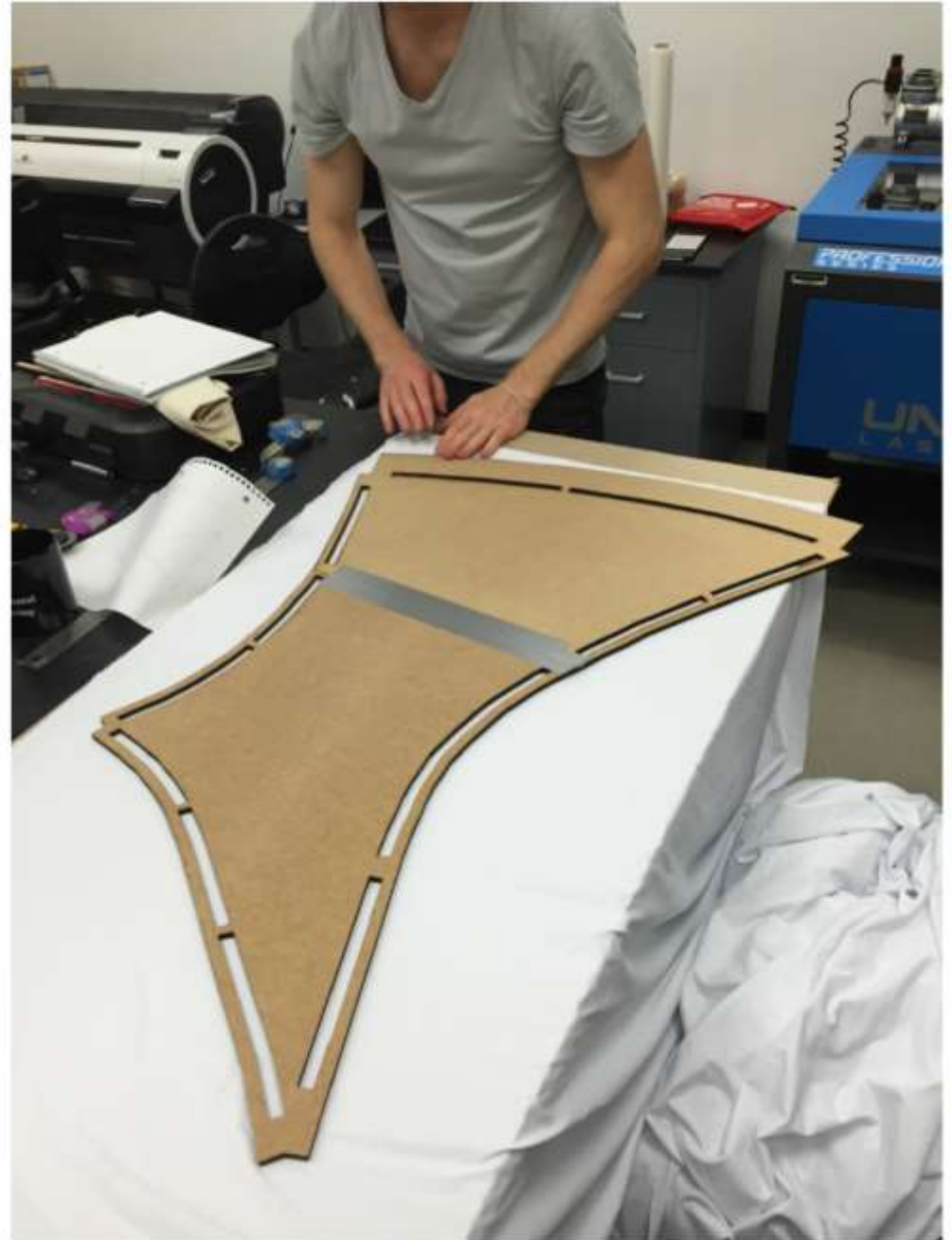

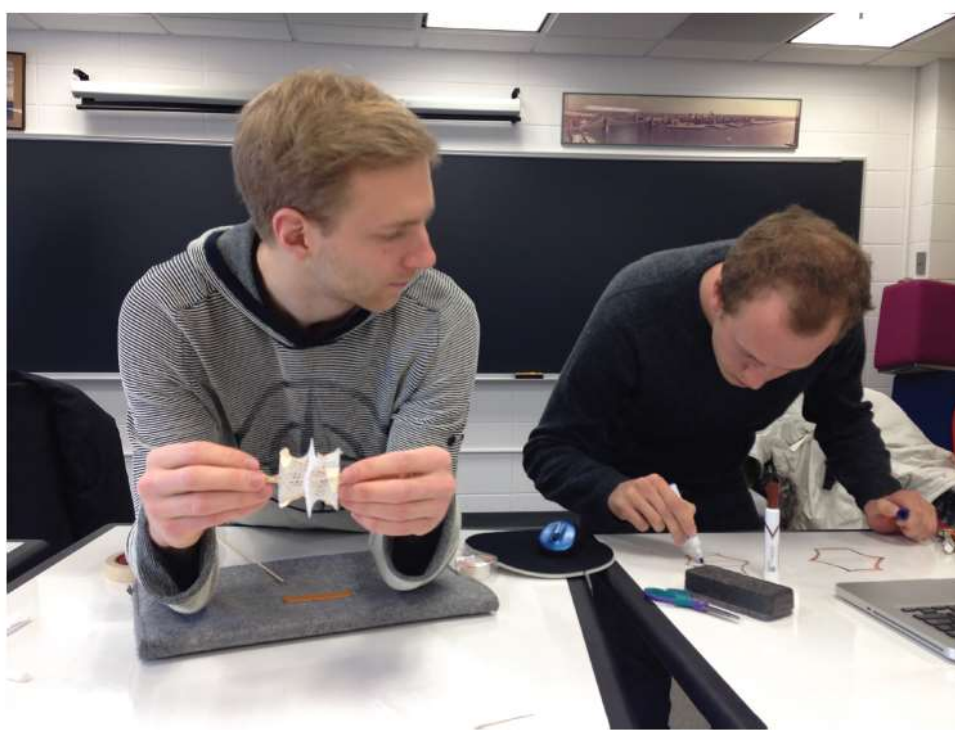

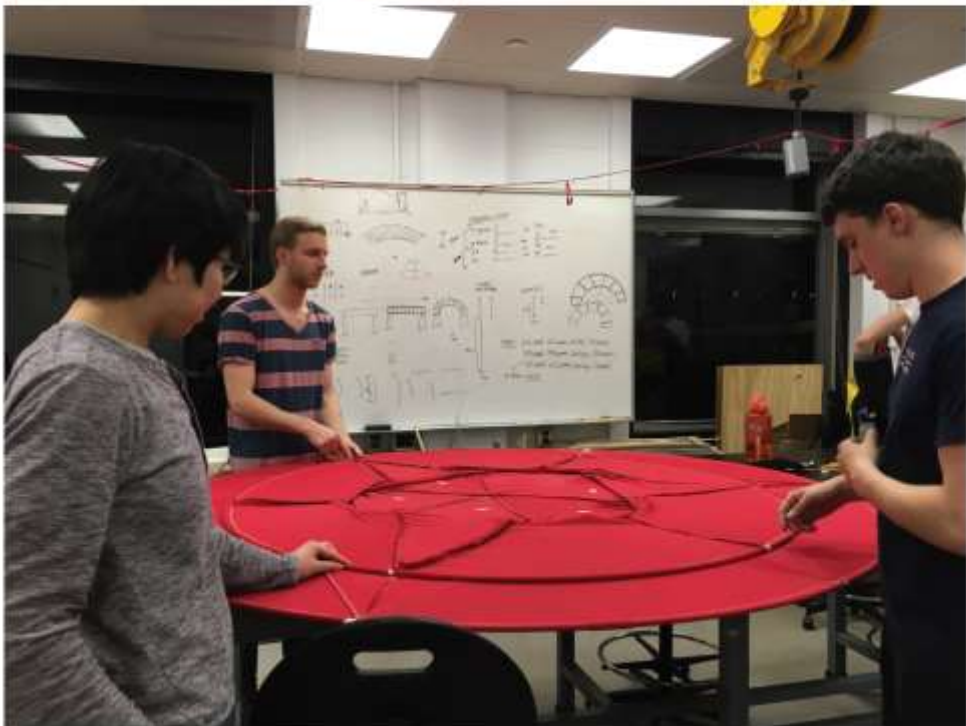
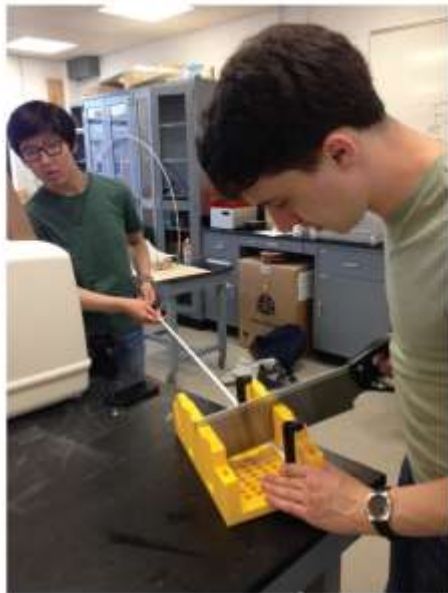

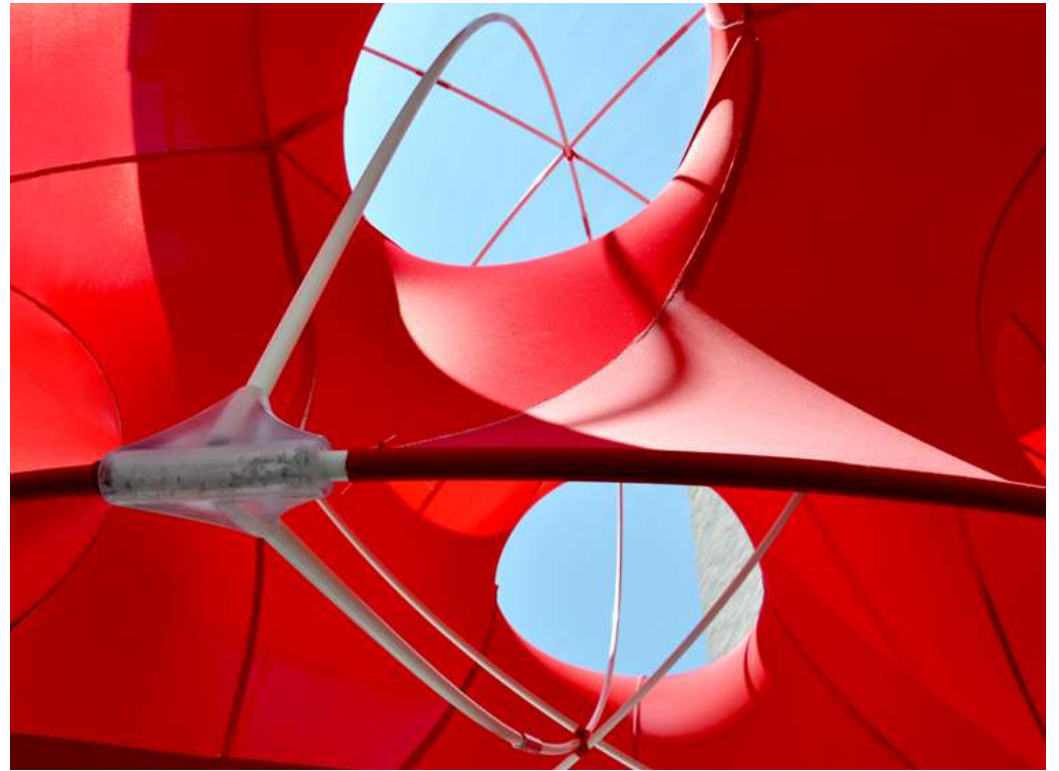
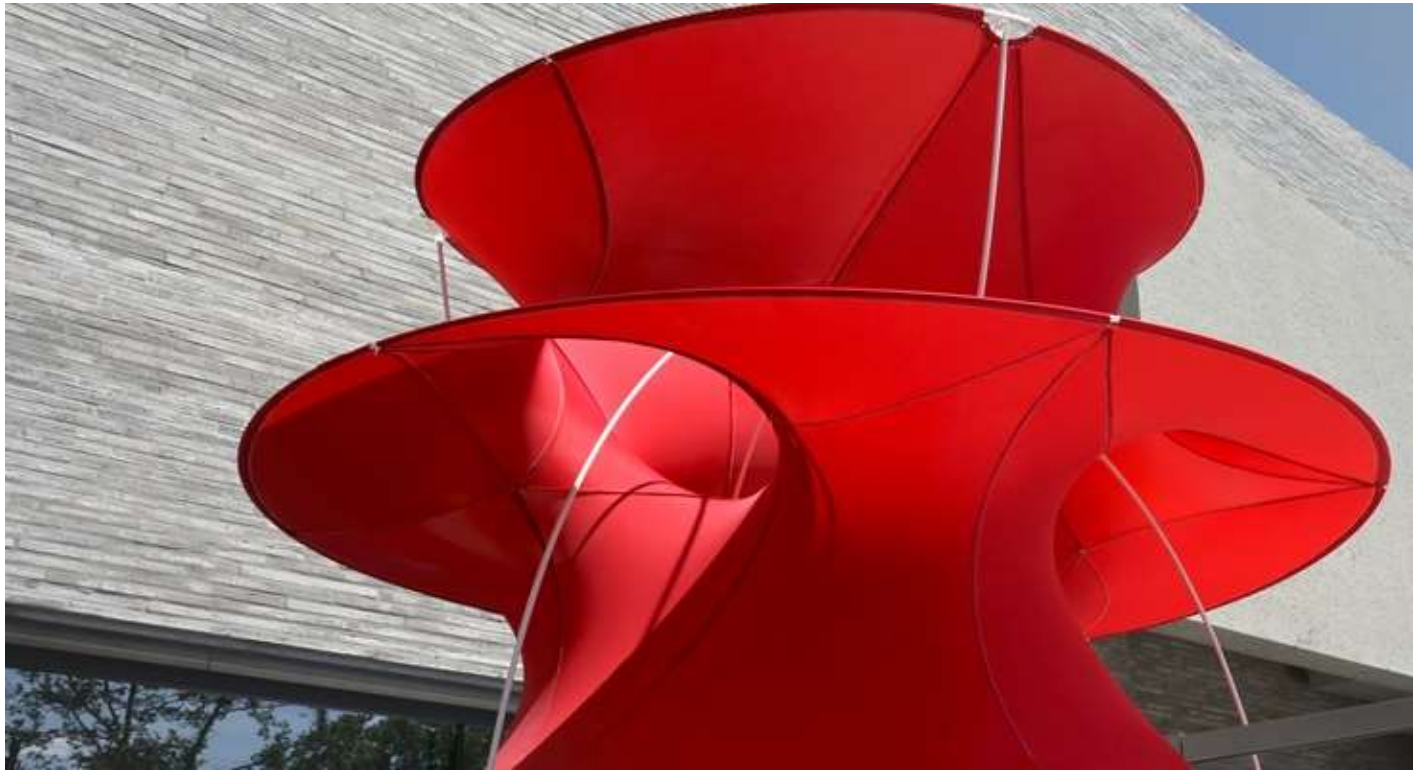

a membrane-tensegrity sculpture
EPUSP, 2017



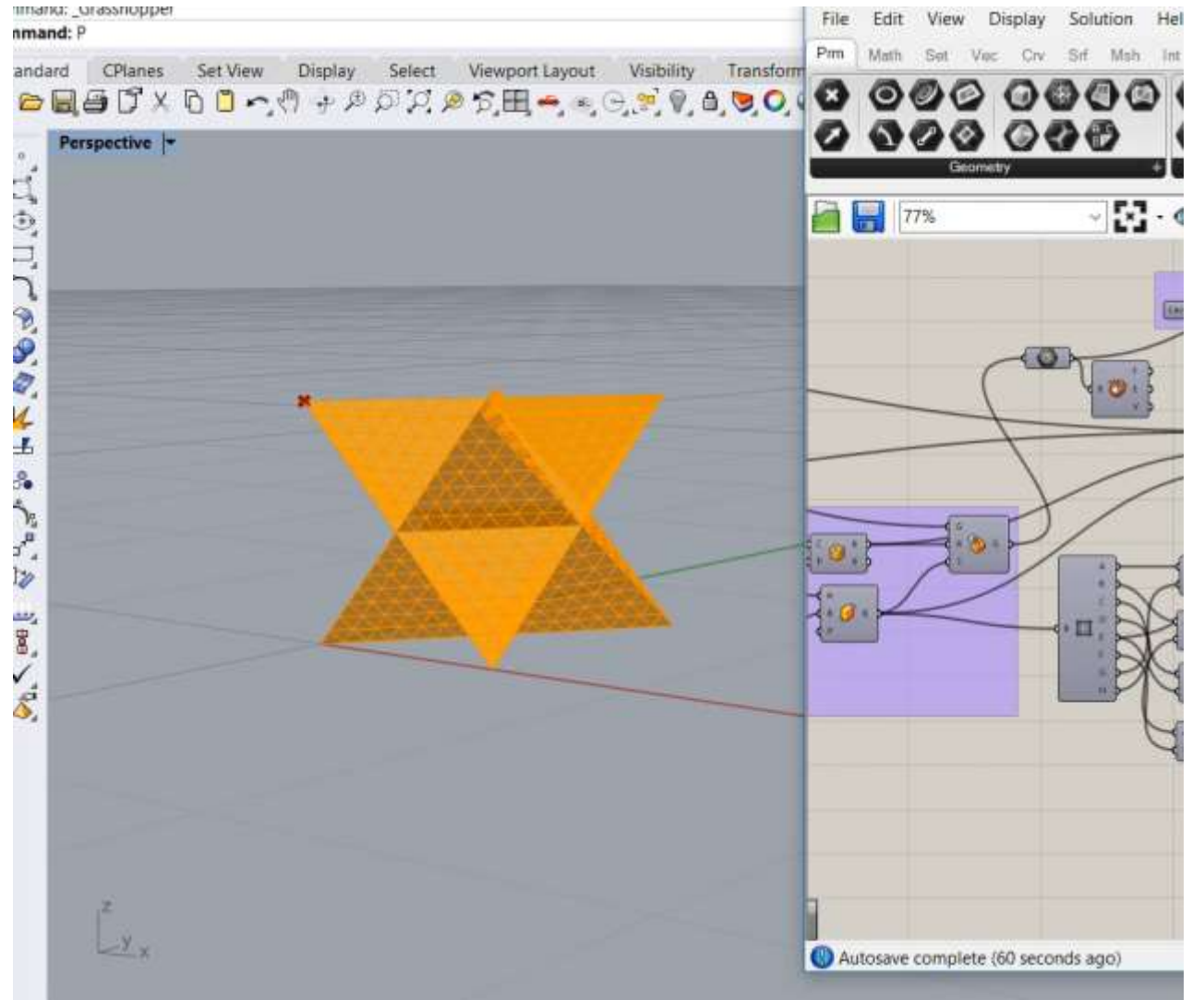
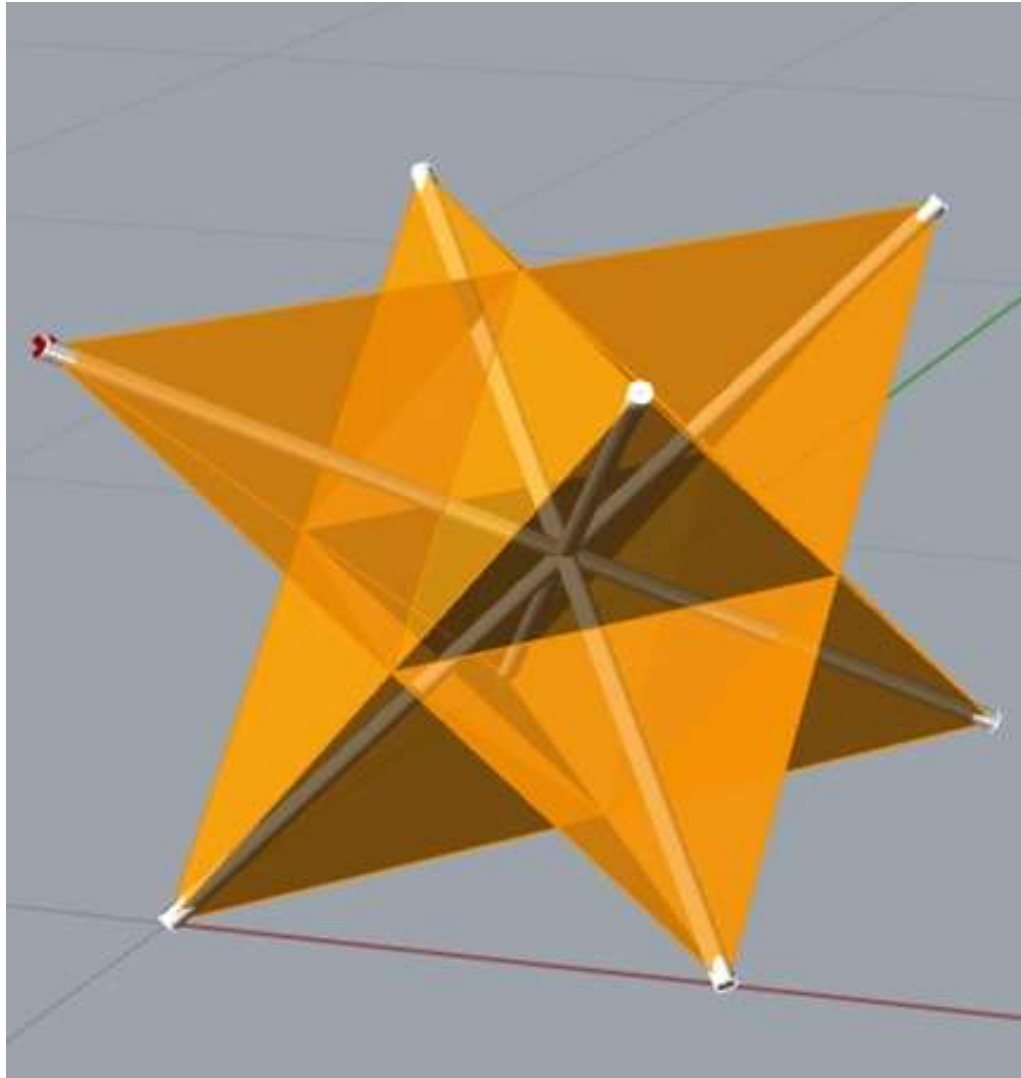

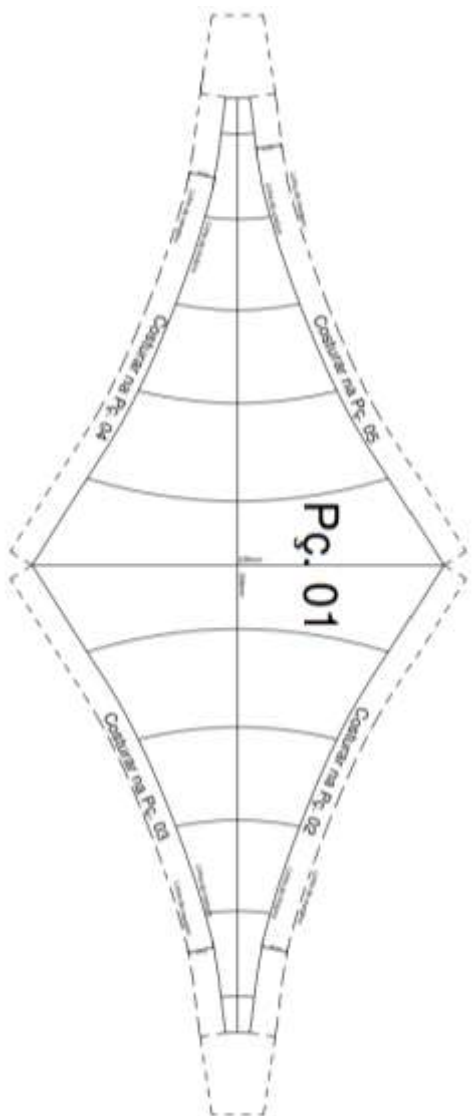
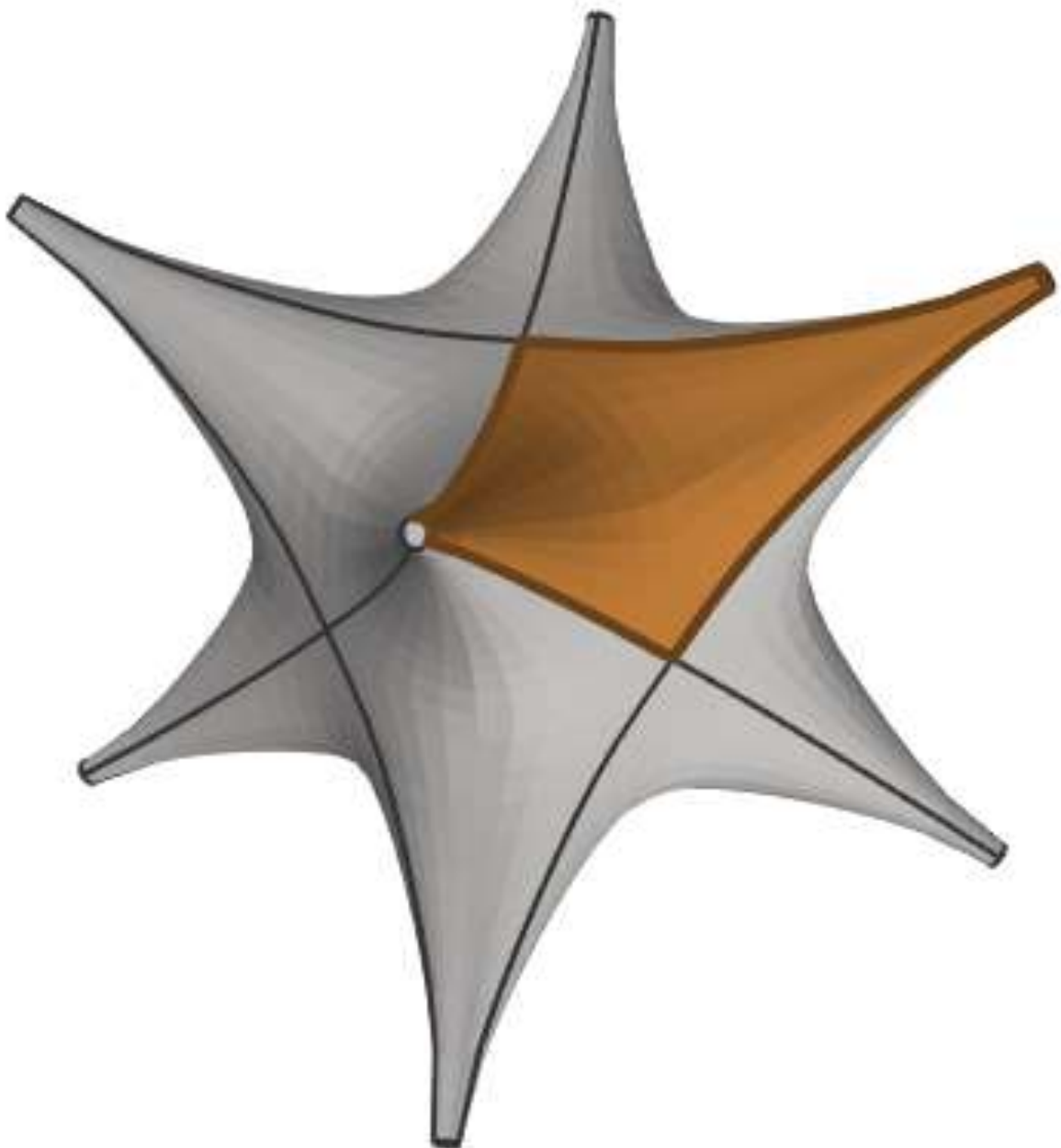

Evolução das cascas e sua influência para o projeto paramétrico



King's College Chapel (1446 - 1515), Arch. Reginald Ely.

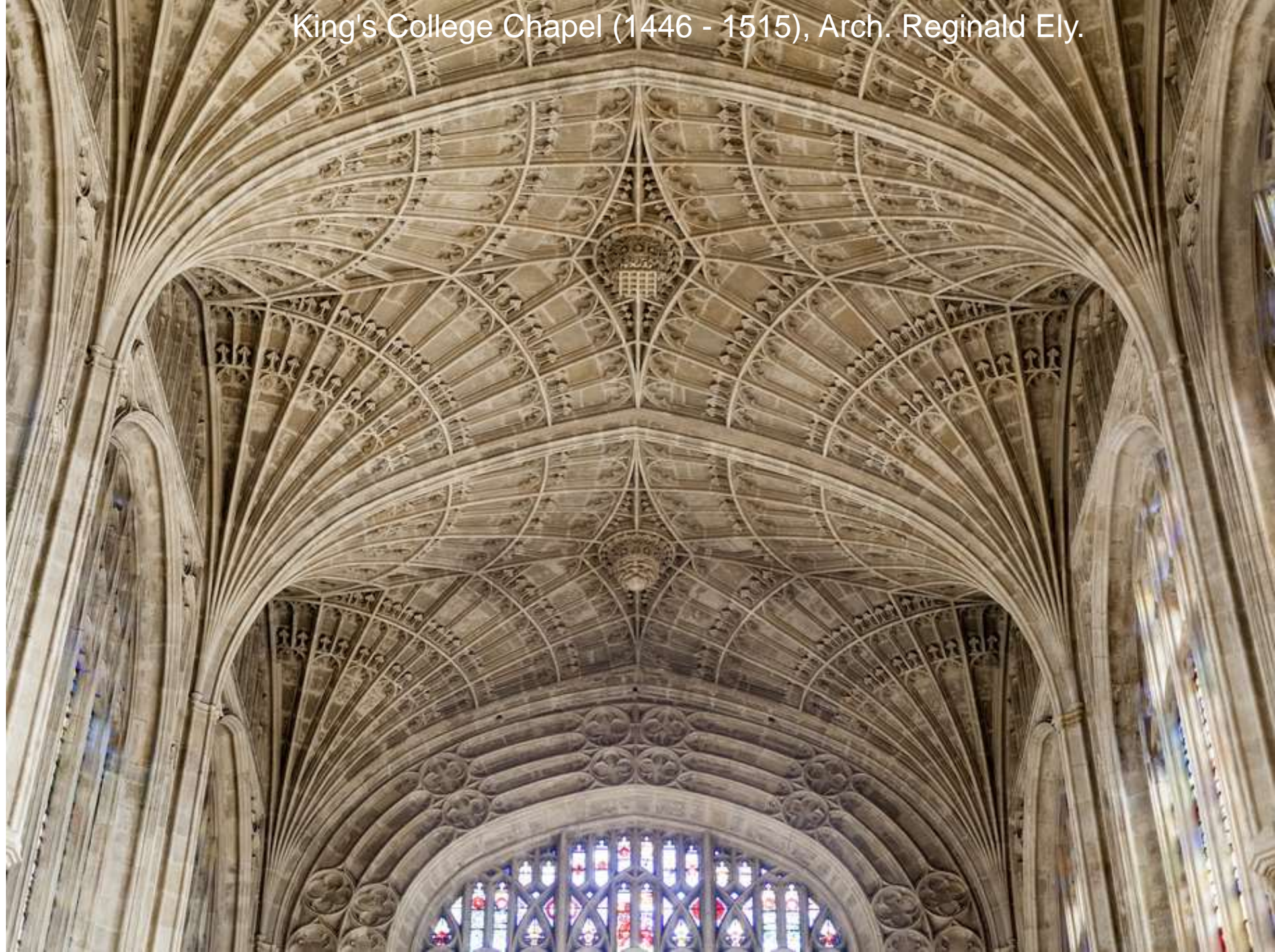



Palazzetto dello Sport – 1956 – 1957
Pier Luigi Nervi, Annibale Vitellozzi, 1960 Olympic Games

**Restaurante Los Mananciales,
Felix Candela (1957)**



St. Louis Abbey (or the Priory Chapel)

Gyo Obata of Hellmuth, Obata & Kassabaum
(HOK) with Pier Luigi Nervi, consultant, 1962

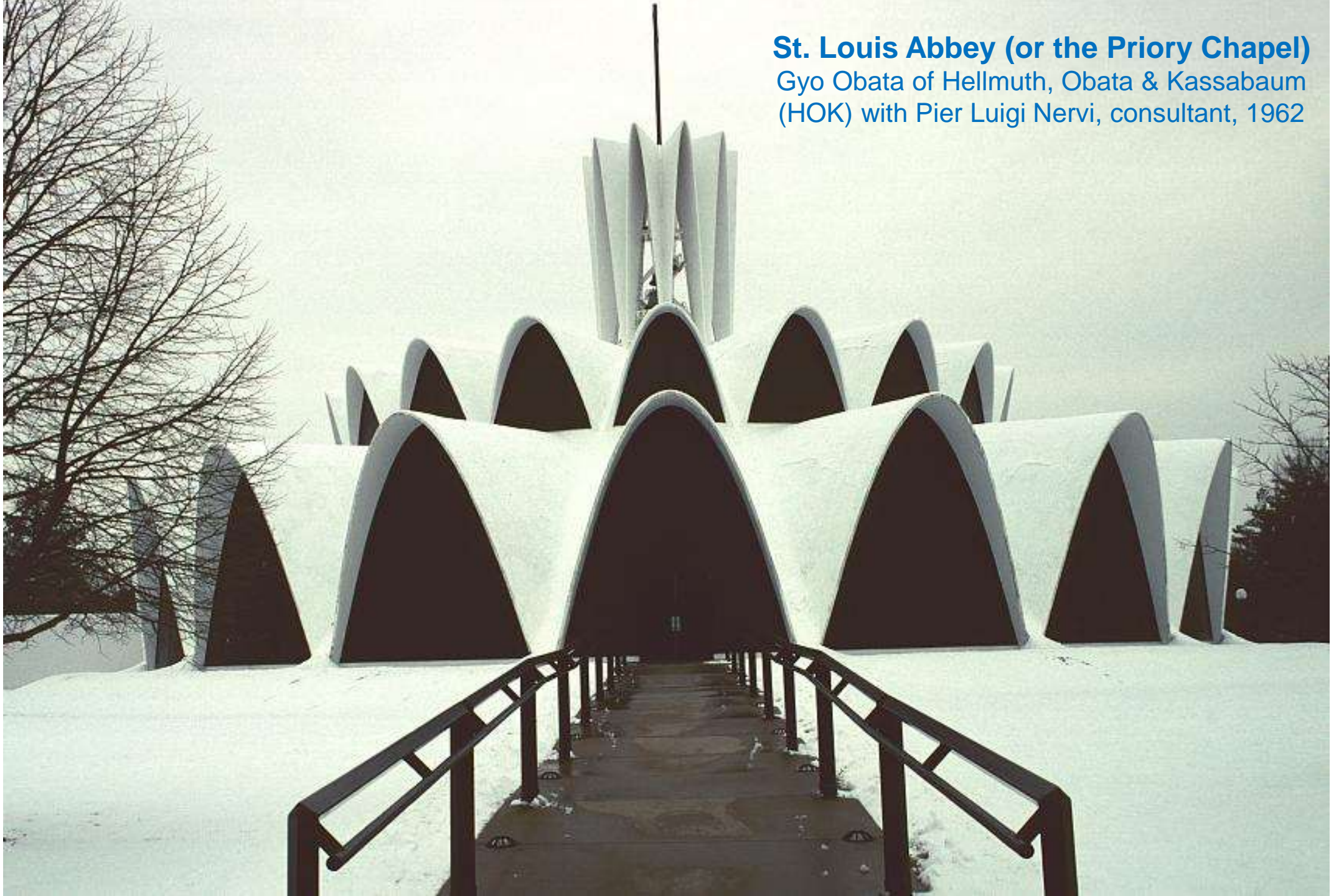



H. Isler, Wyss Garden Center, Suíça, 1961

TWA Flight Center, Eero Saarinen, 1962
JFK International Airport, NY.







Sydney Opera House (1958 – 1973)

Concept designer Jørn Utzon; Architect E. H. Farmer , Peter Hall, David Littlemore, Lionel Todd ; Engineer: Ove Nyquist Arup



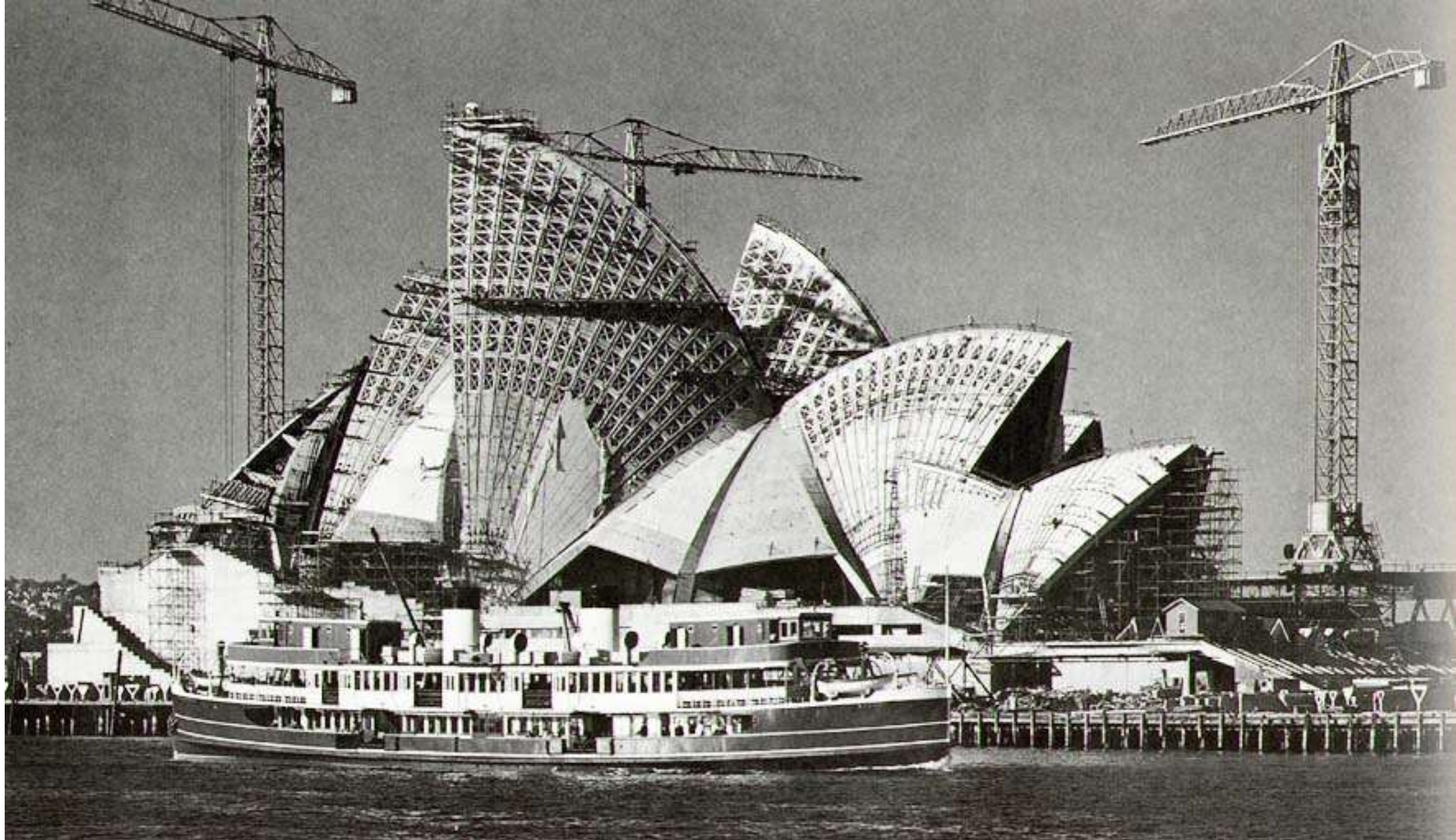

Auditorio de Tenerife,
Arch. Santiago Calatrava (1997-2003)







Museum Guggenheim Bilbao (1982-1987)
Arch. Frank Gehry



*Fiera di Milano Exhibition Centre, Milan, Italy
Massimiliano Fuksas, 2005*







*Metropol Parasol
Arq. Jürgen Mayer H. Architects (2011)*





*Centro Heydar Aliyev, Azerbaijão (2013)
Arqs. Zaha Hadid, Patrik Schumacher*







*Arnhem Central Station, the Netherlands, 2015
Architects: UNStudio*









*Bosjes Chapel, Witzenberg, South Africa, 2017
Steyn Studio (UK) & TV3 Architects (SA)*











Zaha Hadid's
Morpheus Hotel,
Macau
(2013-2018)

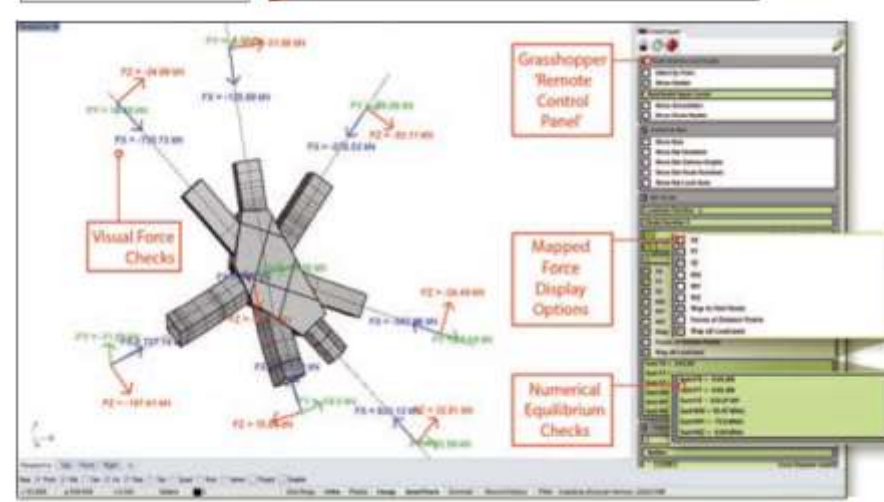
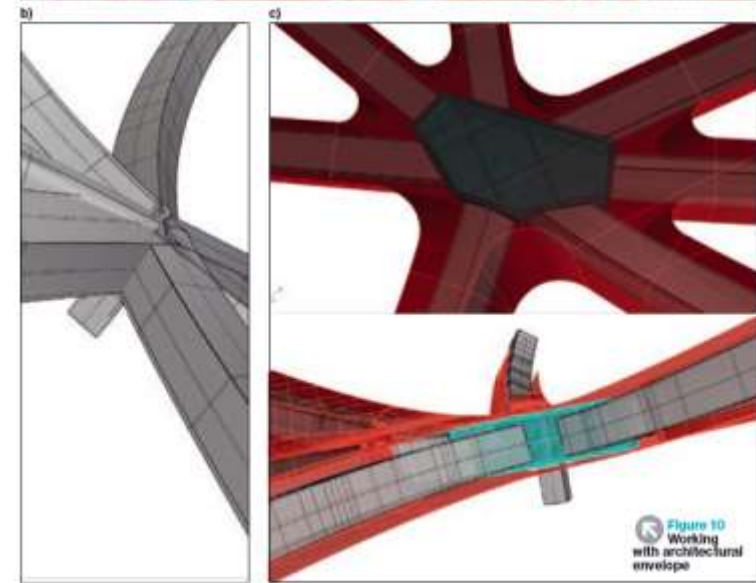
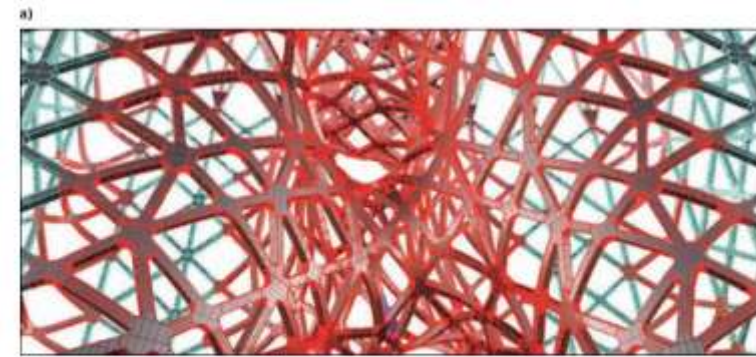
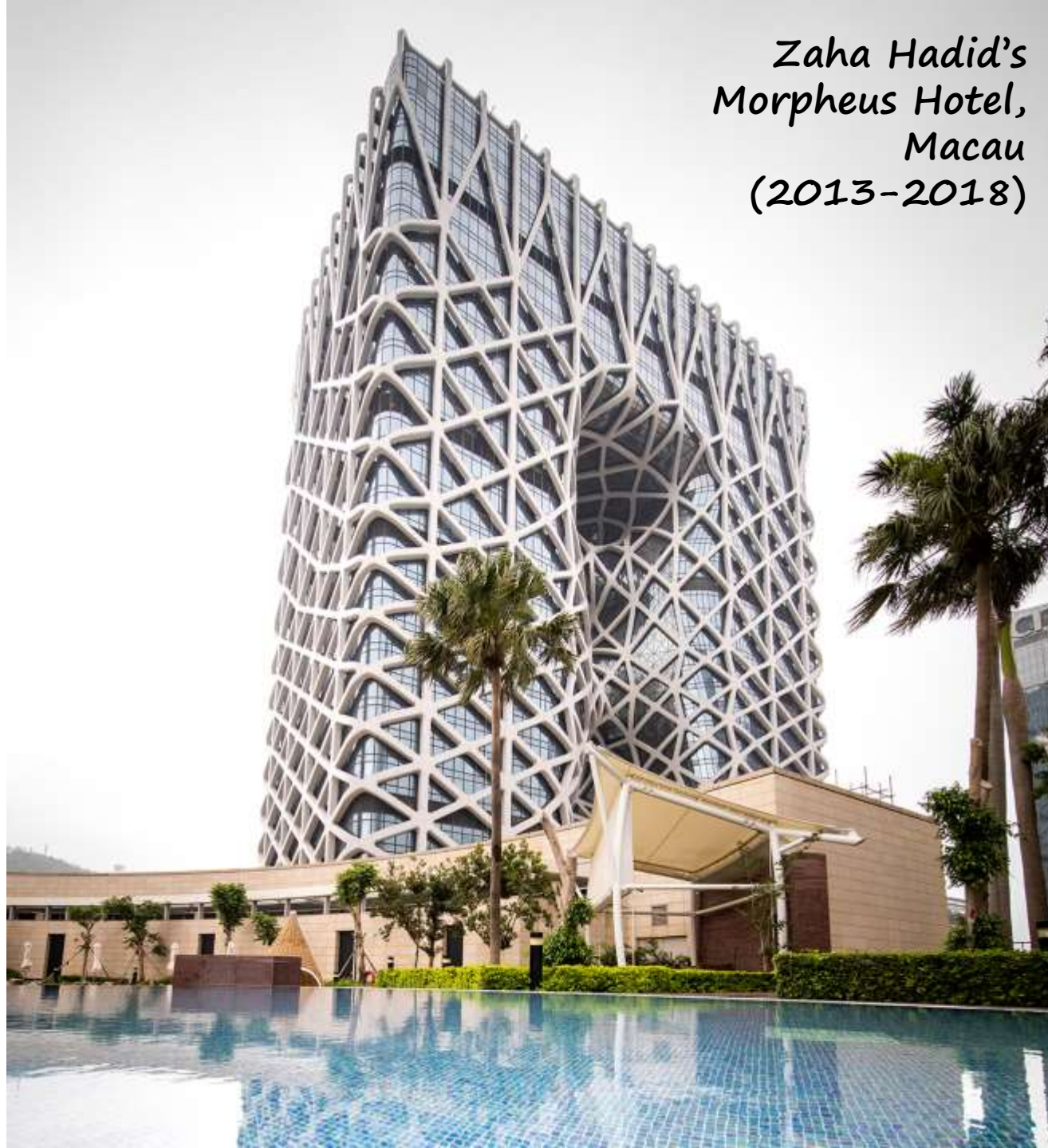

Figure 10
Working
with architectural
envelope

