

# SEM 0564 - DESENHO TÉCNICO MECÂNICO I

Notas de Aulas v.2018

## **Aula 03 – Cortes, hachuras, semi-cortes, corte composto e seções**

Prof. Assoc. Carlos Alberto Fortulan

Departamento de Engenharia Mecânica  
Escola de Engenharia de São Carlos  
Universidade de São Paulo

# Corte

É a denominação dada à representação de um produto seccionado por um ou mais planos virtuais (planos secante).

Mimetiza a um seccionamento físico, pelo corte se representa o que está atrás do plano secante, e algumas das linhas que estavam invisíveis passam a ficar visíveis.

É um recurso muito utilizado para representar mais efetivamente detalhes internos de componentes ou montagens.

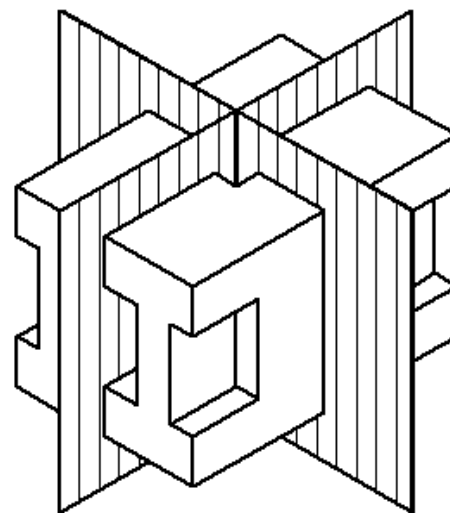
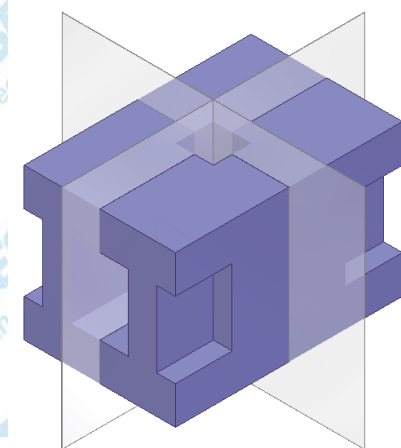
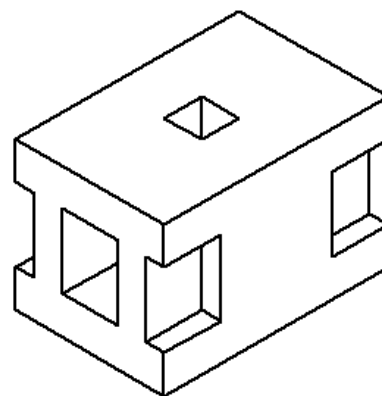

# Corte – planos secantes

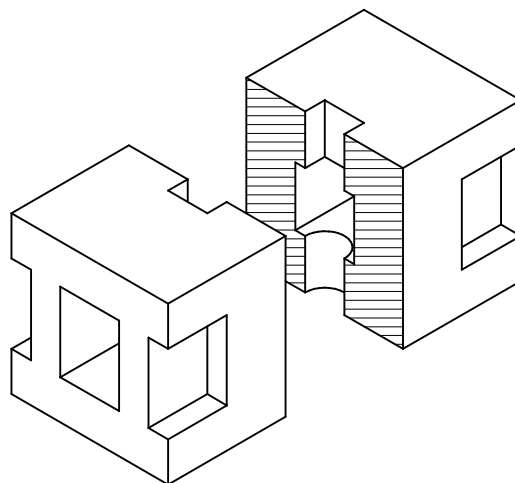
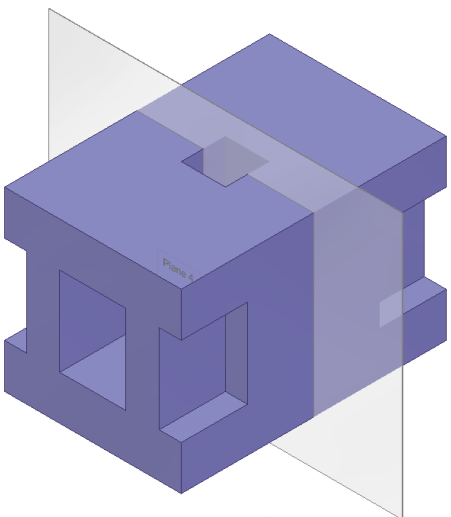
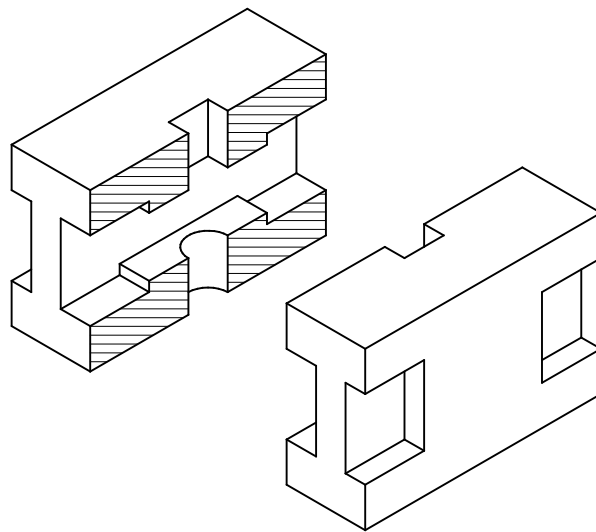
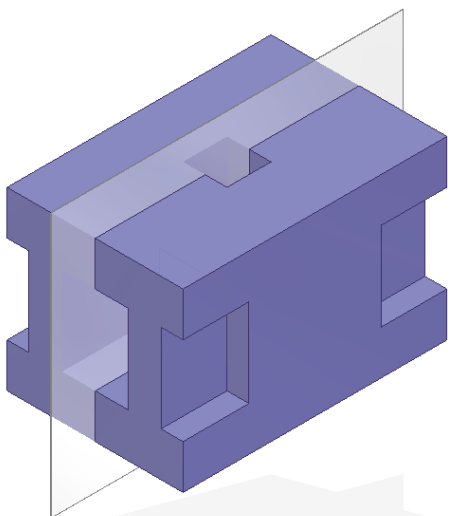

# Corte - vistas

Identifica-se o sentido e posição do observador com setas e denomina-se letras para cada seta.

- As expressões AA, BB, ... são posicionadas embaixo da vista cortada;
- As vistas não atingidas pelo corte permanecem com todas as linhas.

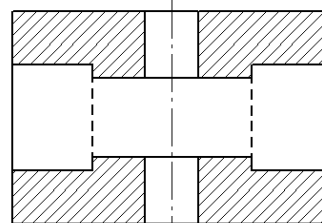
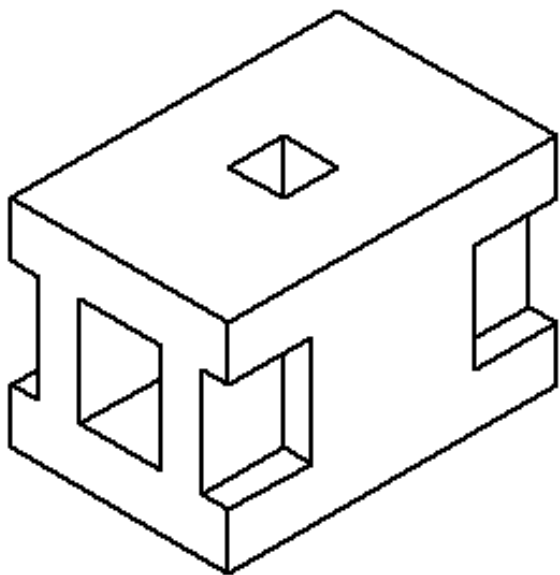

Corte AA

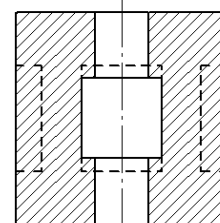

Corte BB

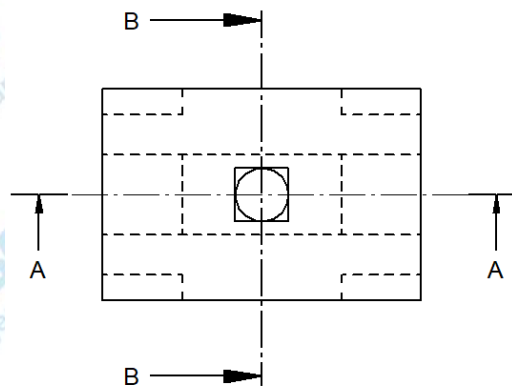

- Na vista cortada, as linhas tracejadas podem ser omitidas desde que isto não dificulte a leitura do desenho

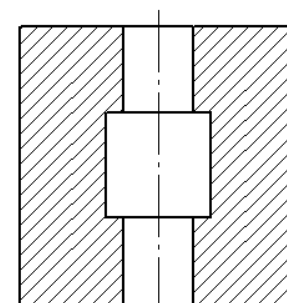
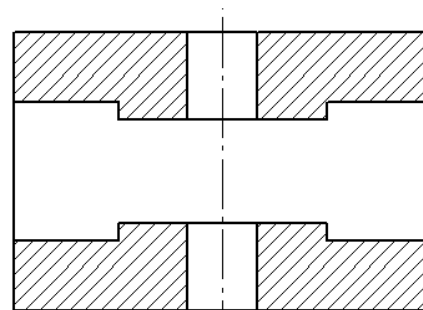
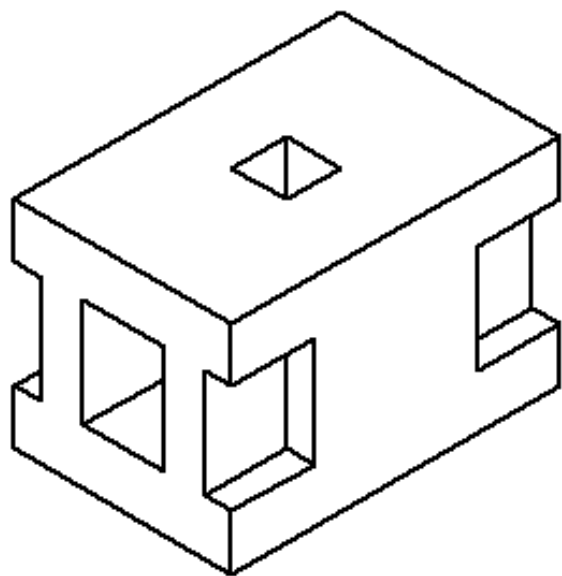

Corte AA

Corte BB

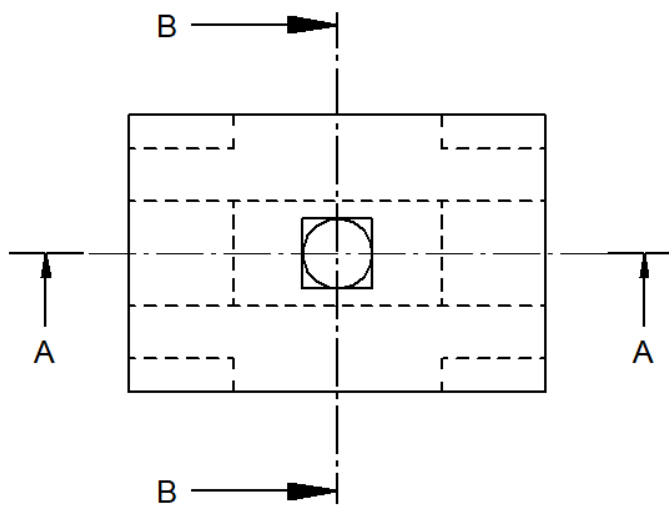

# Corte – planos secantes – Posicionamento e direção

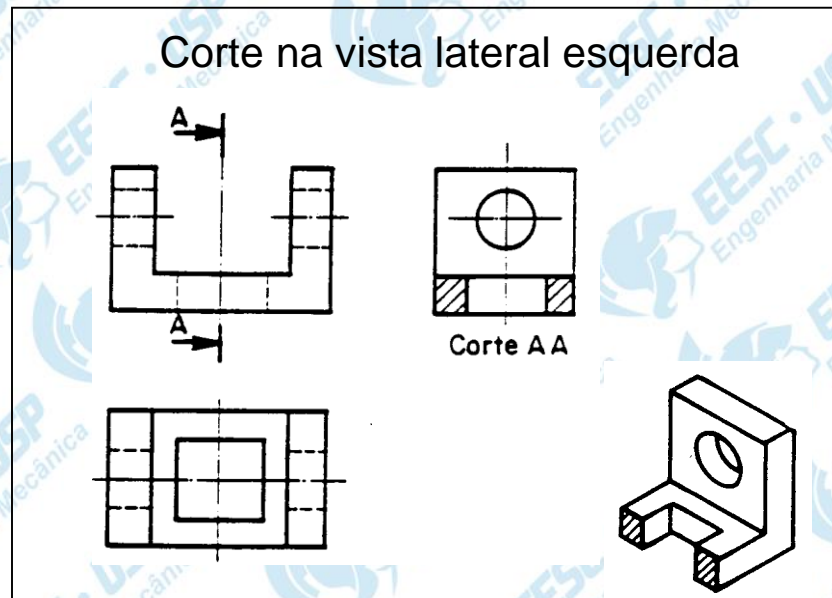
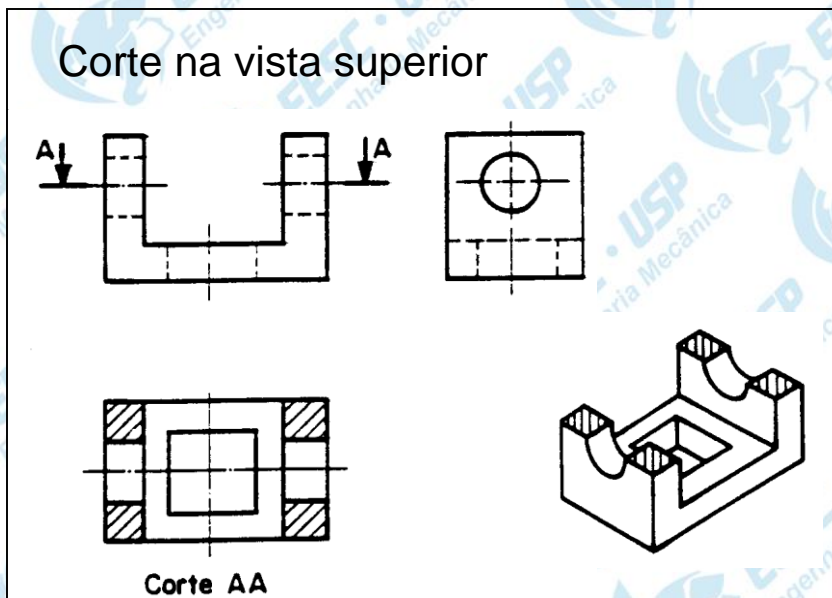
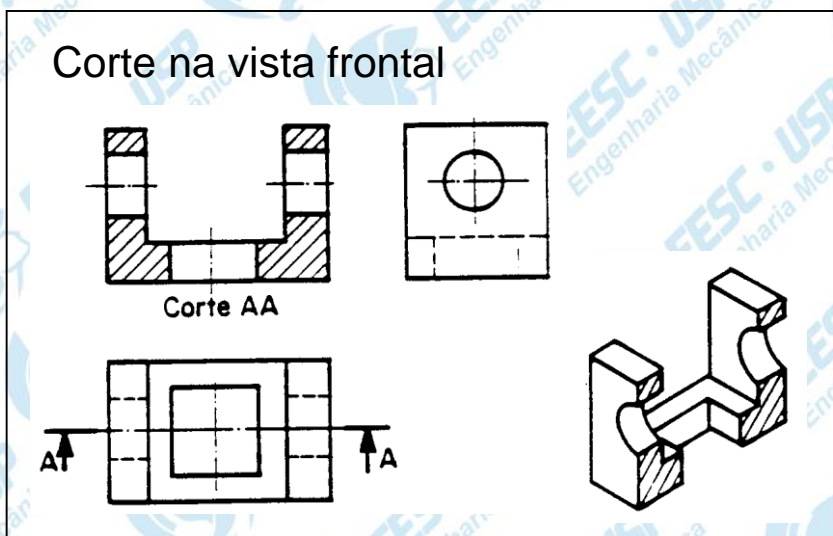
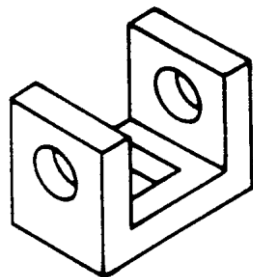

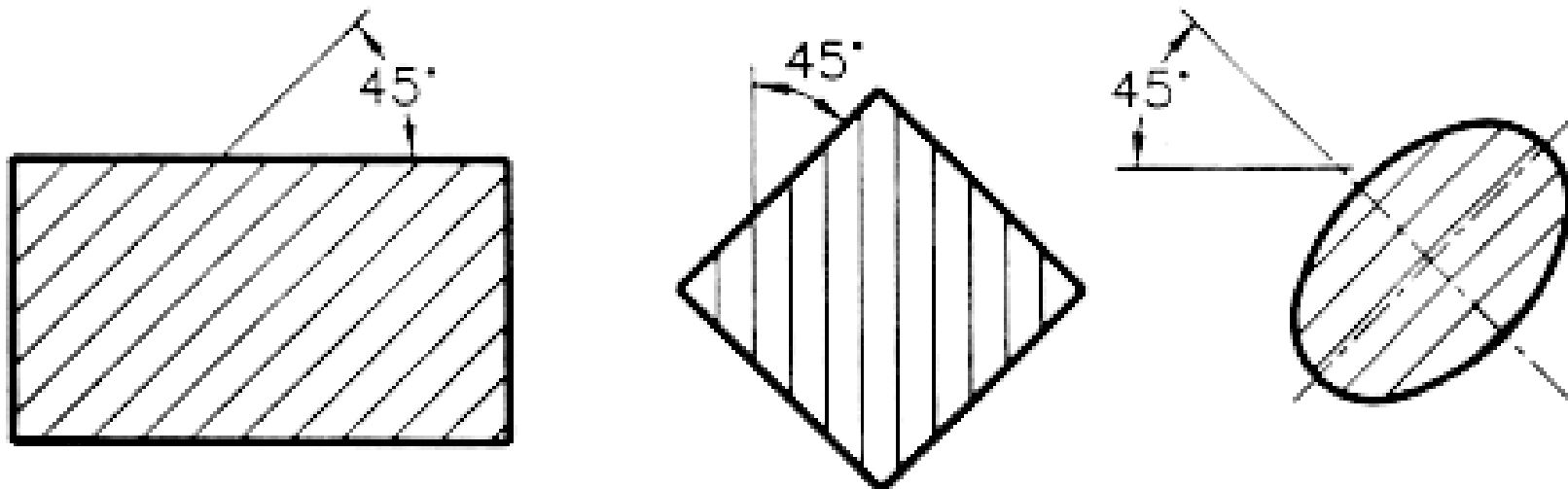

# Hachuras

Na projeção em corte, a superfície imaginada cortada é preenchida com hachuras que são linhas estreitas geralmente traçadas a  $45^\circ$ , porém em alguns casos é permitido uma inclinação de  $30^\circ$ .

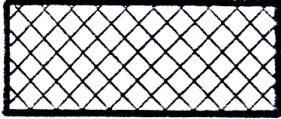
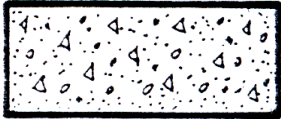
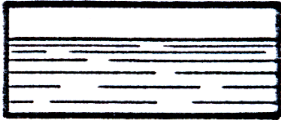

A representação remete inicialmente a imagem deixada por um corte de serra em um aço.

Hachuras específicas, correspondentes a certos materiais que podem ser empregadas.

Hachura	Material
	Elastômeros, vidros cerâmica e rochas
	Concreto
	Líquido
	Madeira
	Terra

Imagens: NBR 12298 – Representação de área de corte por meio de hachuras em desenho técnico. 1995



# Outras hachuras

Outras hachuras também podem ser utilizadas, devendo estar identificadas (representadas em uma nota ou legenda).

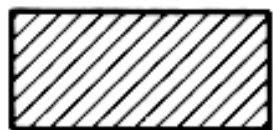

FERRO FUNDIDO



AÇO



LATÃO, BRONZE  
COBRE



ZINCO, CHUMBO  
LIGAS  
ANTIFRICÇÃO



ALUMÍNIO  
MAGNÉSIO  
LIGAS LEVES



BORRACHA  
PLÁSTICOS  
E ISOLANTES

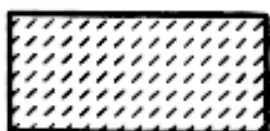

MARMORE, ARDÓSIA  
PORCELANA, VIDRO  
MATERIAL CERÂMICO

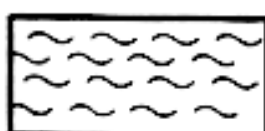

CORTIÇA, FELTRO  
COURO, FIBRA  
TECIDOS



CONCRETO



ALVENARIA



TERRA



ROCHA

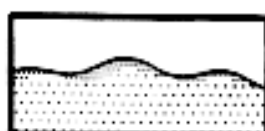

AREIA



LÍQUIDOS



LONGITUDINAL

TRANSVERSAL  
(MADEIRA)

# Hachuras em peças conjugadas

As hachuras em uma peça composta (unidas ou montagem), são feitas em direções diferentes e quando se tem mais que duas peças em contato se muda o distanciamento.

Cortes em componentes de paredes muito delgadas, como por exemplo: chapas, juntas, guarnições, perfis estruturais, devem ser representadas em **negrito** com espaçamento em branco.

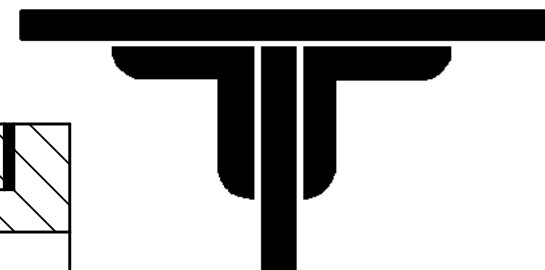
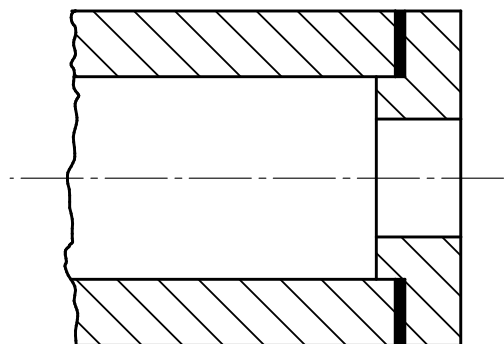
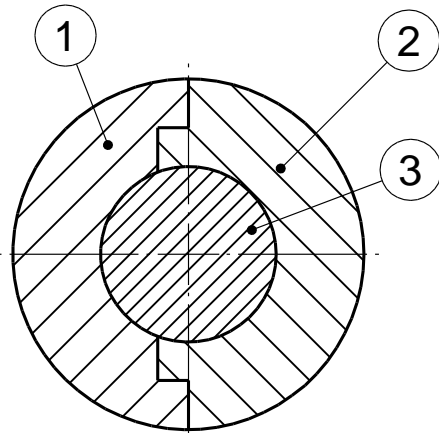
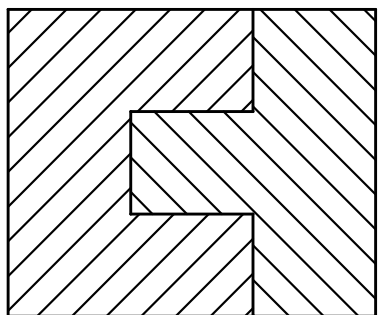

# ELEMENTOS NÃO CORTADOS

Alguns elementos de máquinas não são cortados quando atingido pelo plano secante.

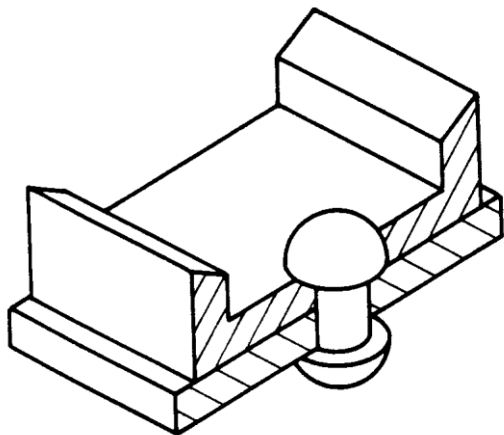

Rebites

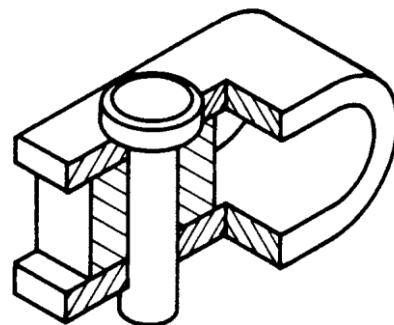

Pinos

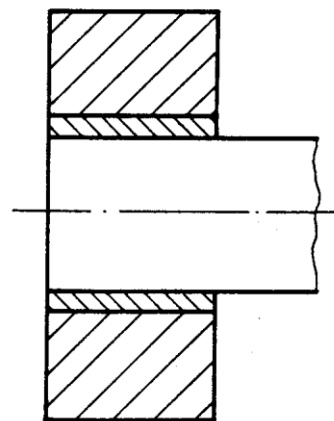

Eixos

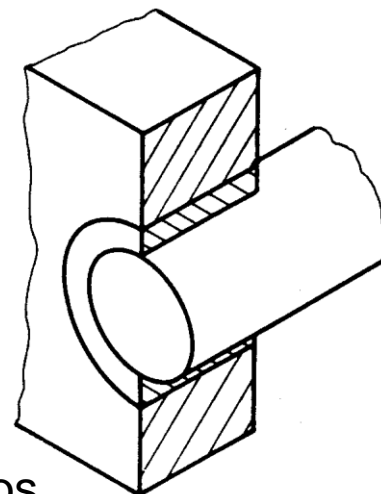
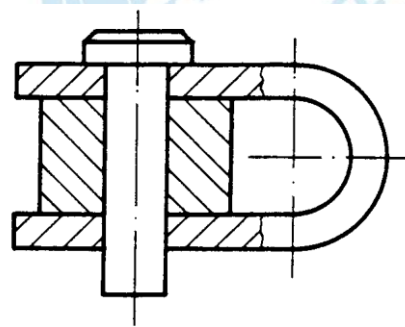
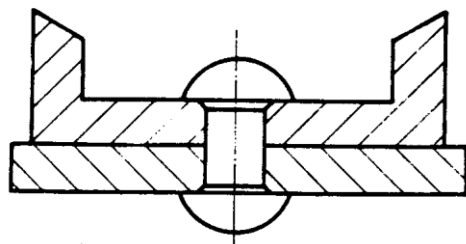

# Elementos não cortados

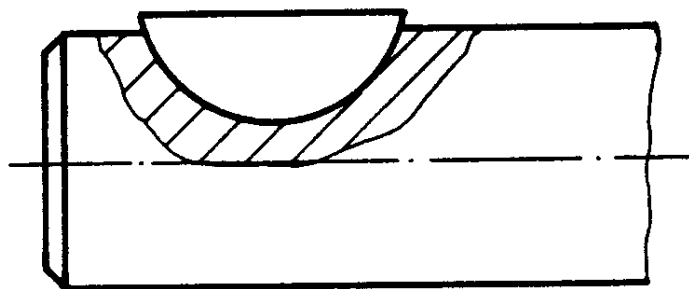
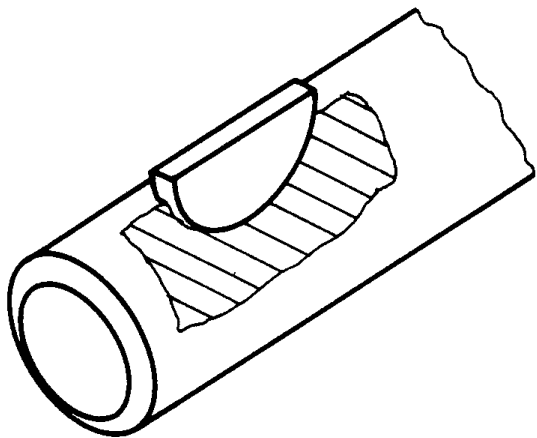

Chavetas

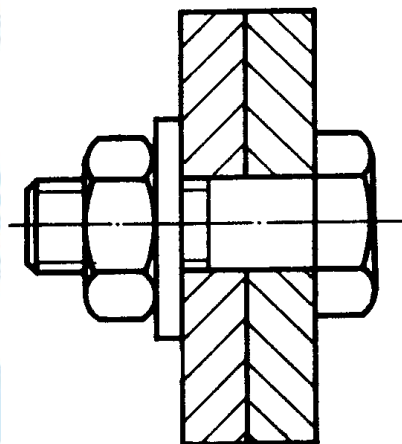
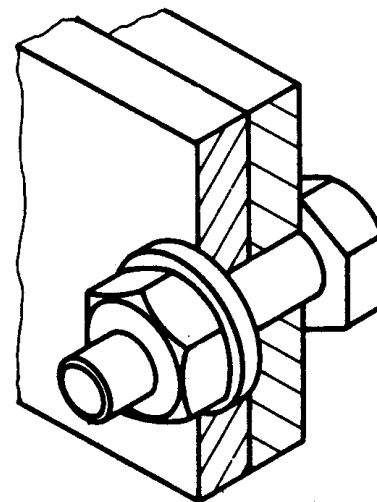

Parafusos, porcas e arruelas

# Corte: múltiplos planos secantes

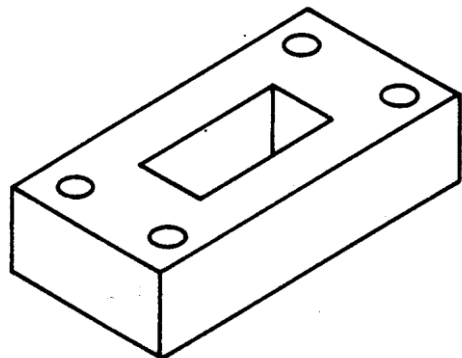

Pelos furos

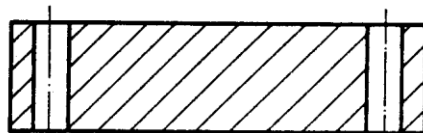

Corte AA

Pelos centro

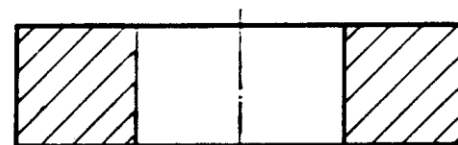

Corte AA

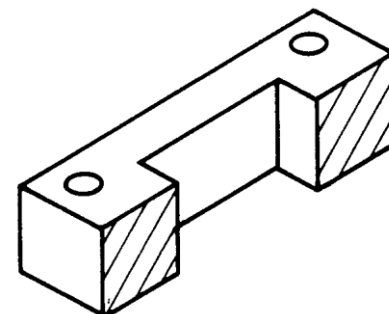
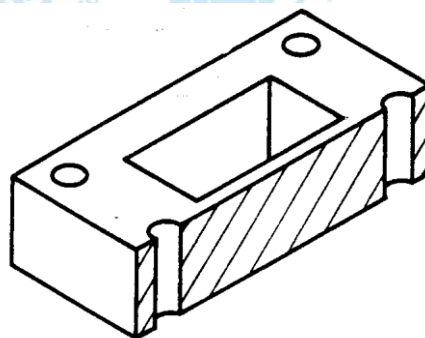
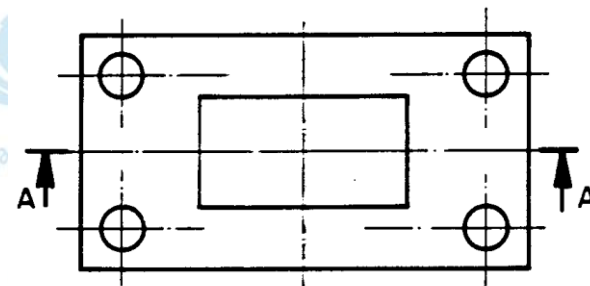
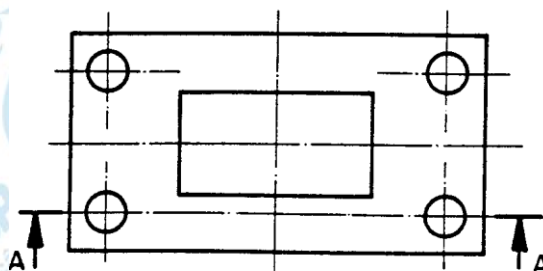

# Corte composto (em desvio)

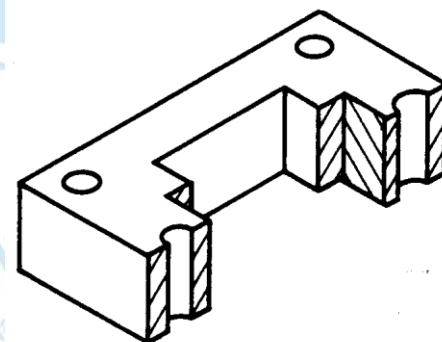
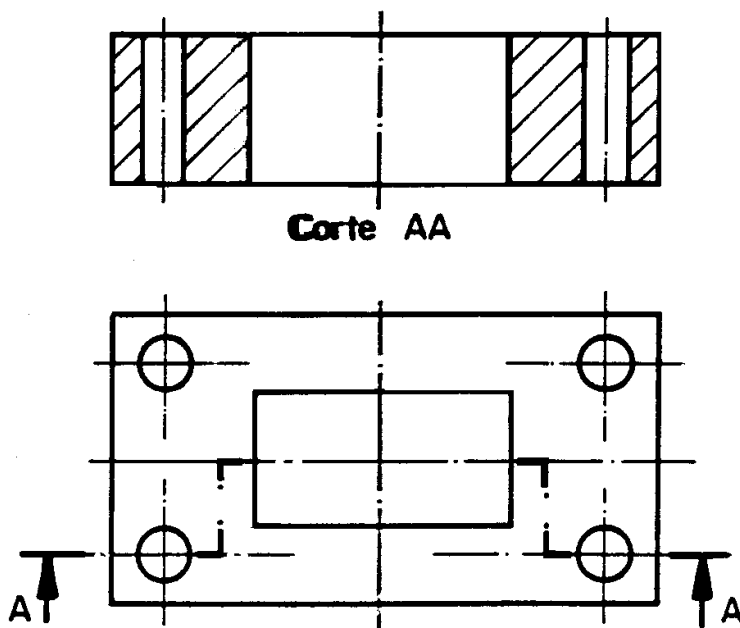

# Corte parcial

Corte apenas para mostrar determinados detalhes internos na projeção. Para limitar a parte cortada, usa-se a linha de ruptura (sinuosa estreita)

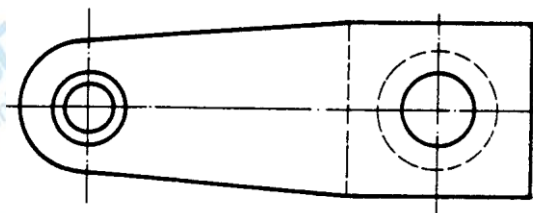
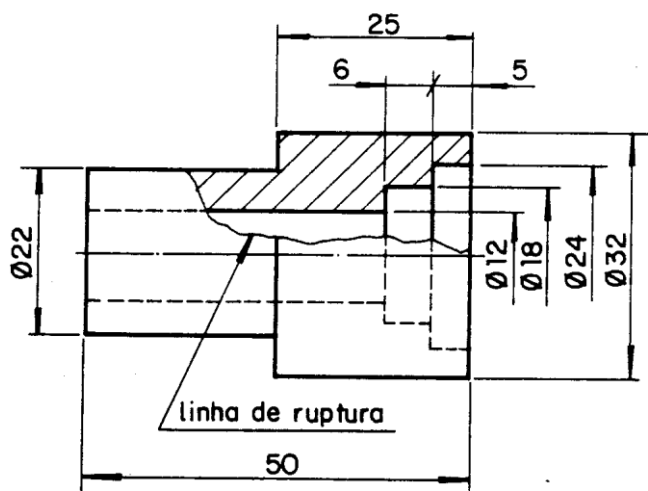
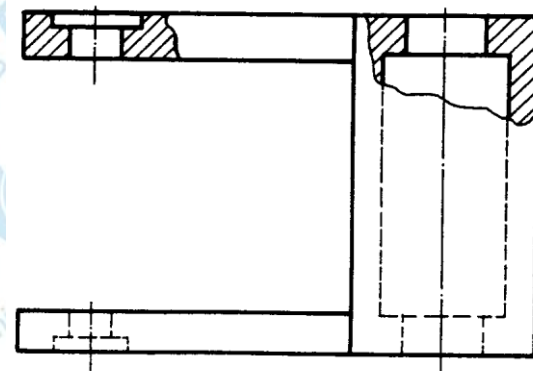
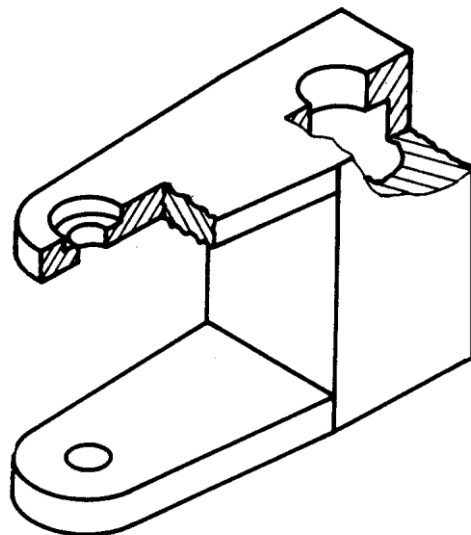

# Corte parcial

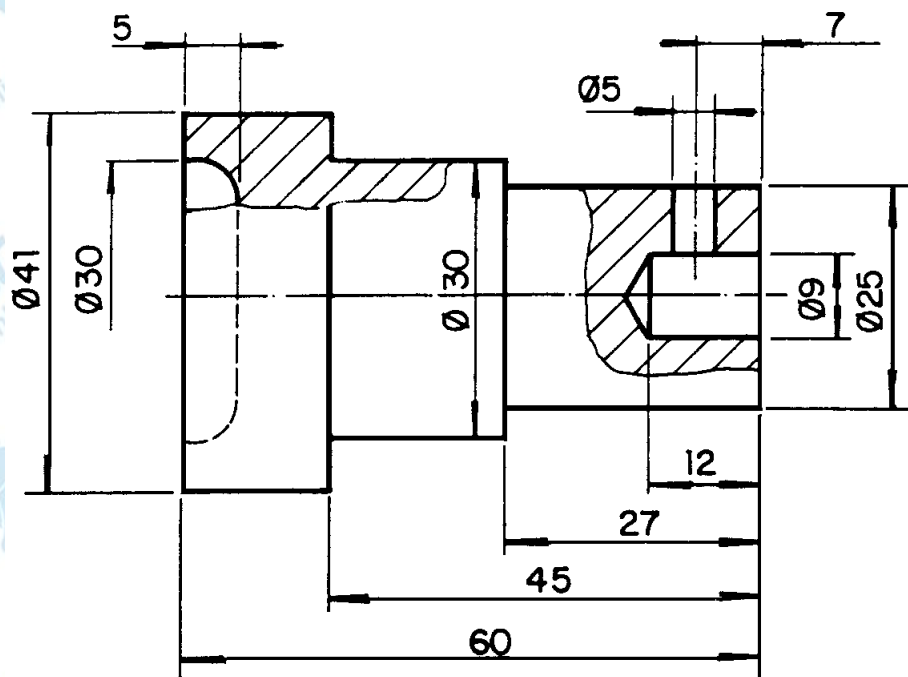
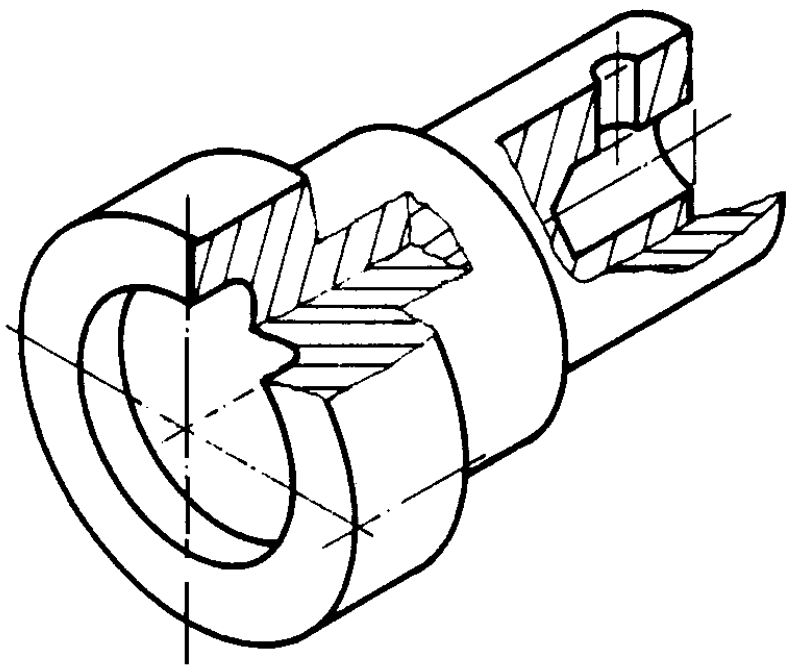



## Meio-corte

O meio-corte é empregado no desenho de peças simétricas no qual aparece somente meia vista em corte. O meio corte apresenta a vantagem de indicar, em uma só vista, as partes internas e externa da peça.

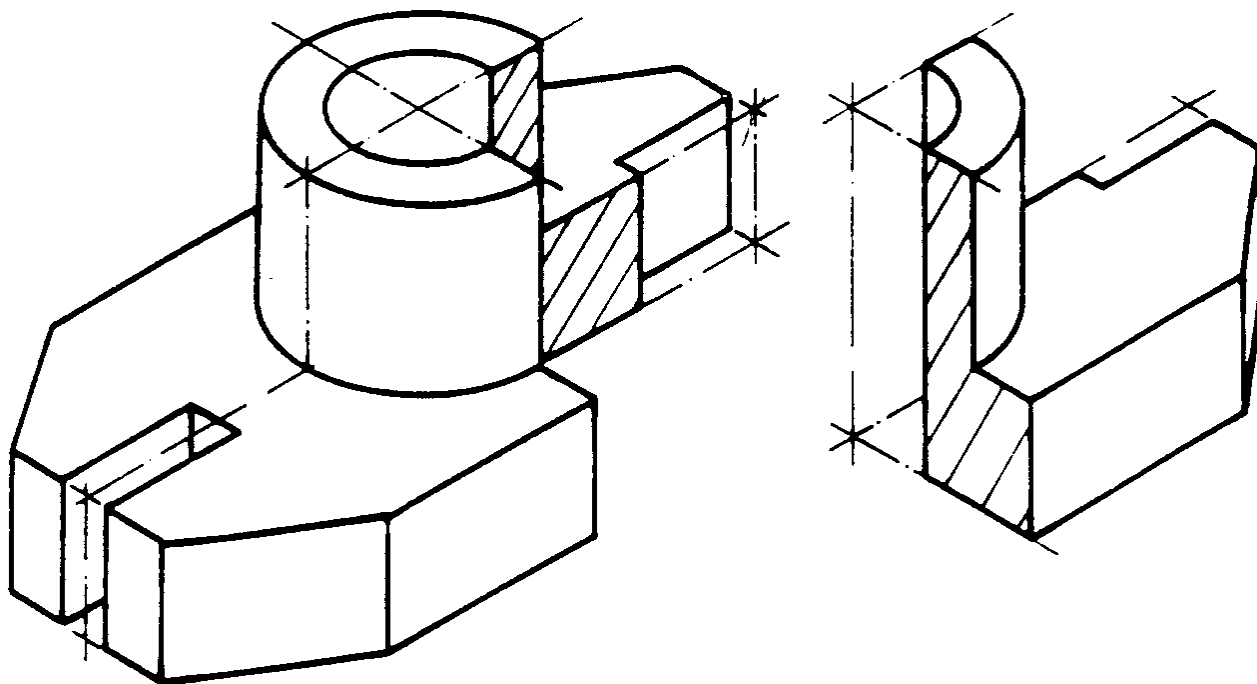

# Meio-corte

Em peças com a linha de simetria vertical, o meio corte é representado à **direita** da linha de simetria.

As linhas tracejadas devem ser omitidas na parte não cortada.

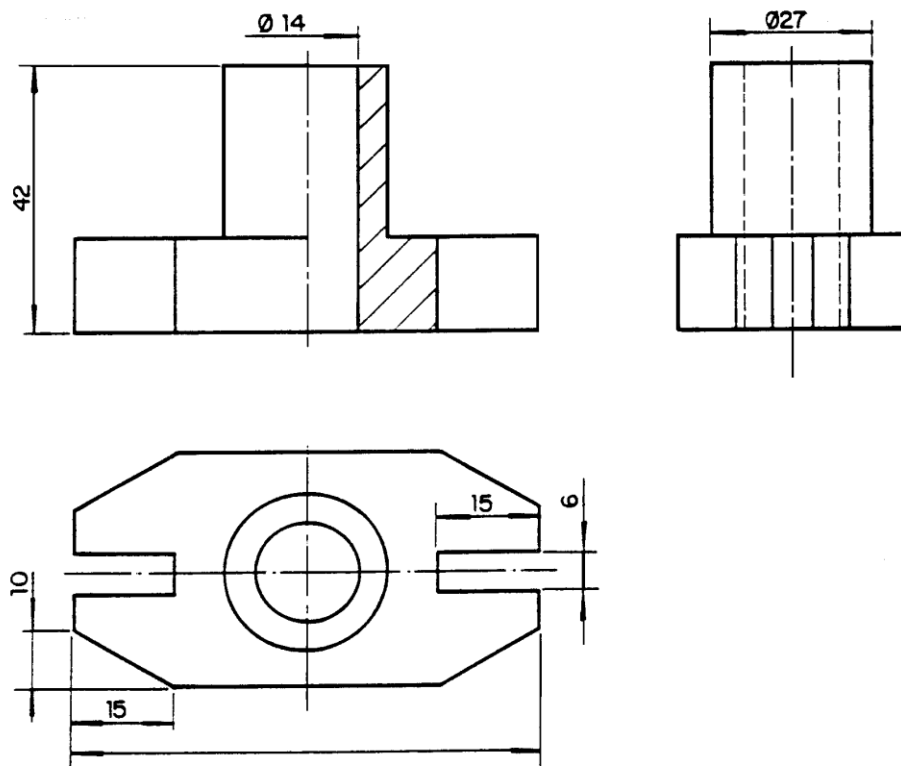
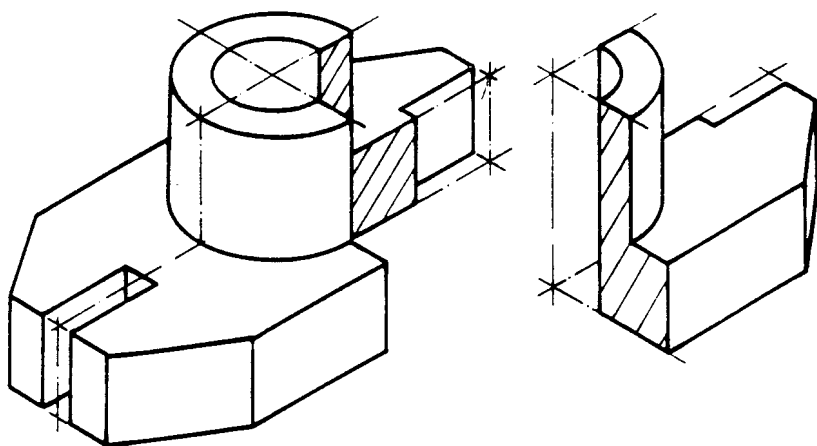

## Meio-corte em vista única

Em peças com a linha de simetria horizontal, o meio corte é representado na parte **INFERIOR** da linha de simetria

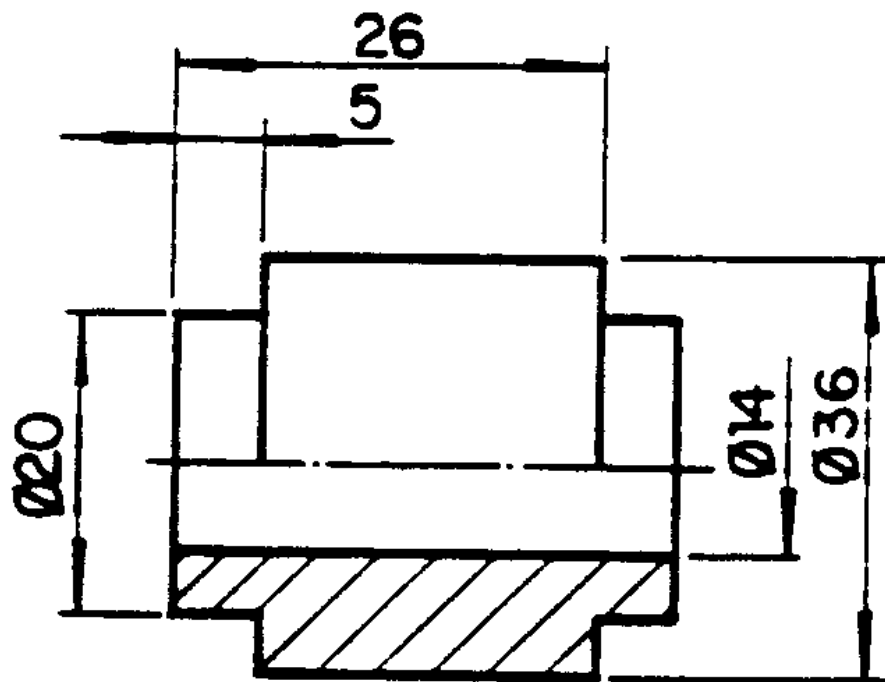
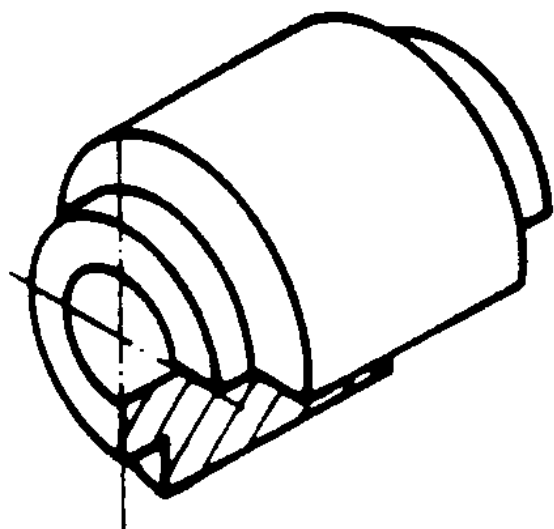

# Meio-corte duas representações em meio corte no mesmo desenho

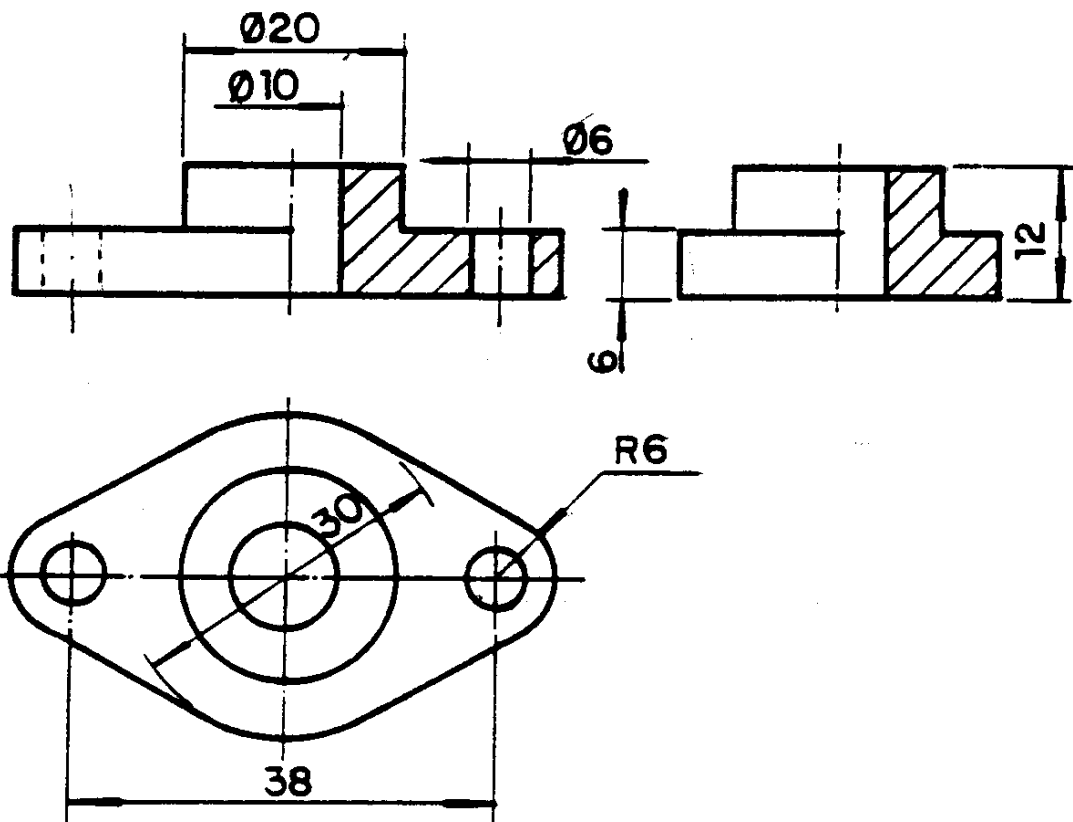
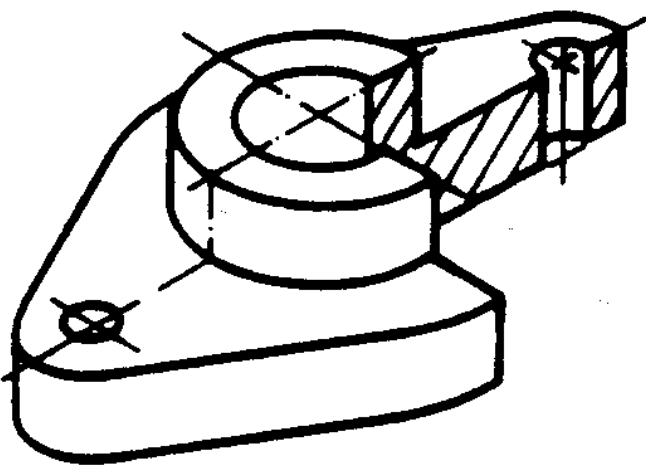

# Seção

Seções são representações de cortes transversais de uma peça, a fim de mostrar de maneira simples seu formato naquela região.

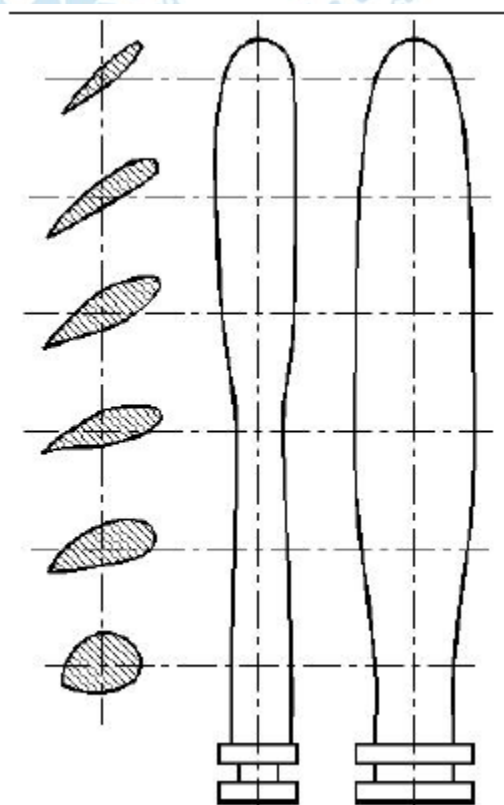

Imagens: Silva, Dias, Sousa. Desenho Técnico Moderno. Lidel Edições Técnicas.

# Seção - Fora da vista com indicação

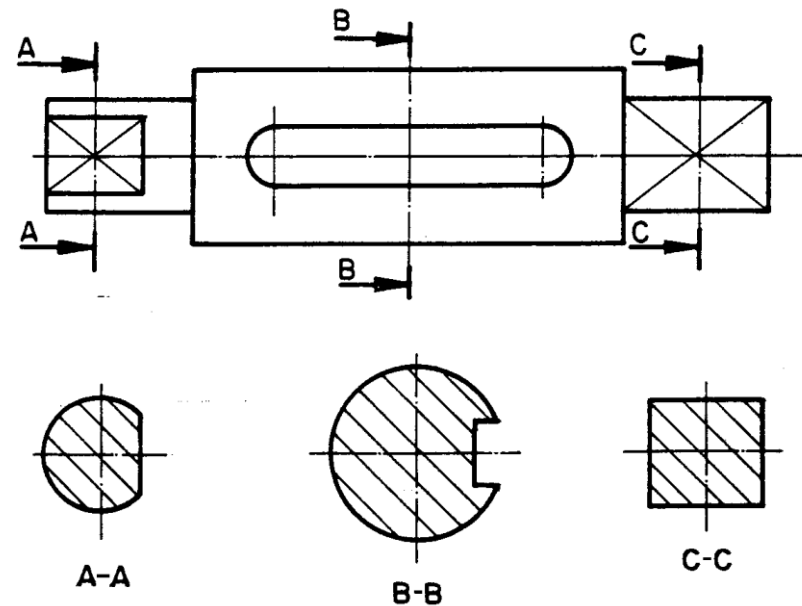
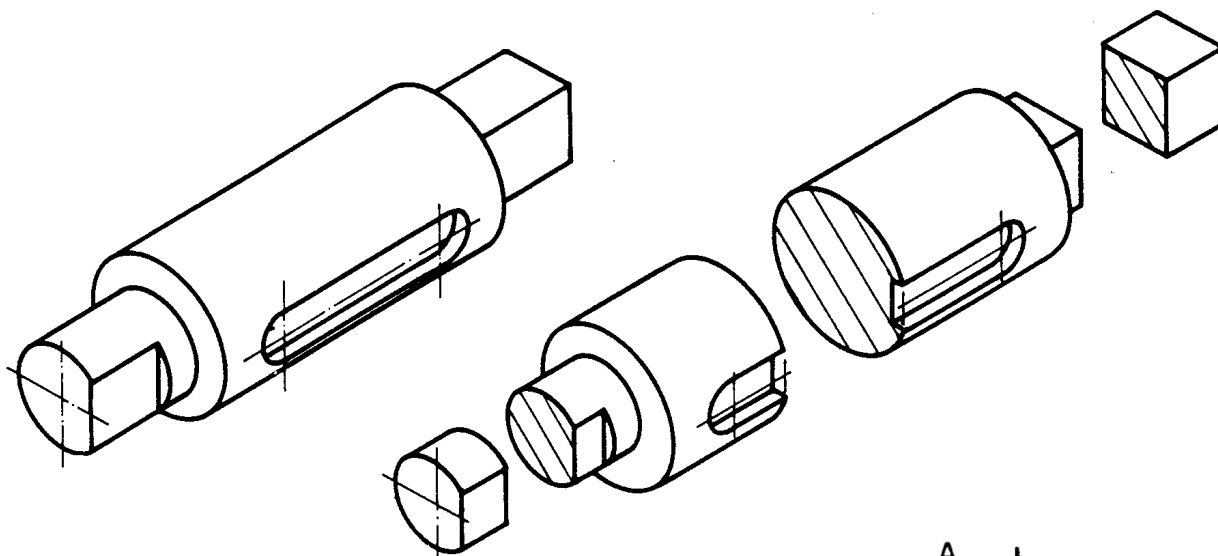

# Exemplo de Seção fora da vista com indicação

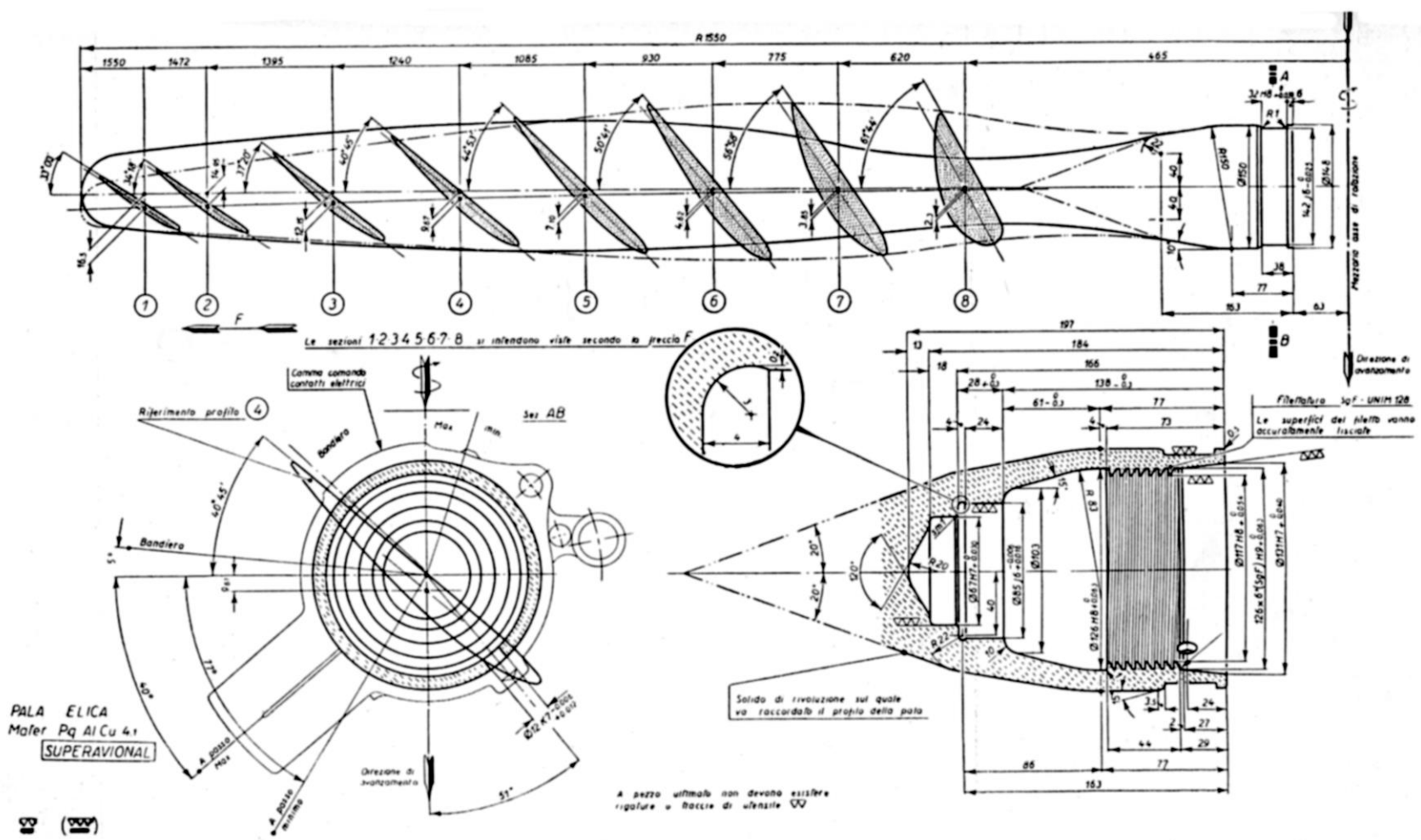

Fonte: SPELUZZI, M & TESSAROTO M. Diseno di Macchine. Ed. ULRICO HOEPLI, Milão

Sez. ① Camp. 16.5

Incl.  $33^{\circ}03'$   
 $s: 820 \text{ mm}^2$

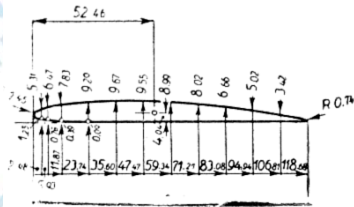

Sez. ② Camp. 14.95

Incl.  $34^{\circ}18'$   
 $s: 1180 \text{ mm}^2$

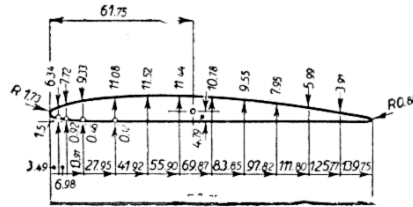

Sez. ③ Camp. 12.15

Incl.  $37^{\circ}20'$   
 $s: 1920 \text{ mm}^2$

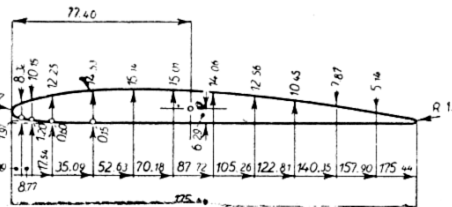

Sez. ④ Camp. 9.61

Incl.  $40^{\circ}45'$   
 $s: 2880 \text{ mm}^2$

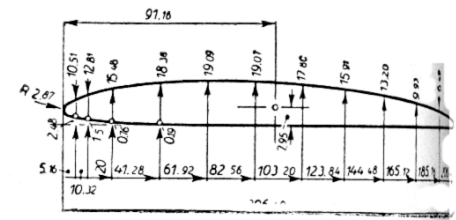

Sez. ⑤ Camp. 2.10

Incl.  $44^{\circ}53'$   
 $s: 3850 \text{ mm}^2$

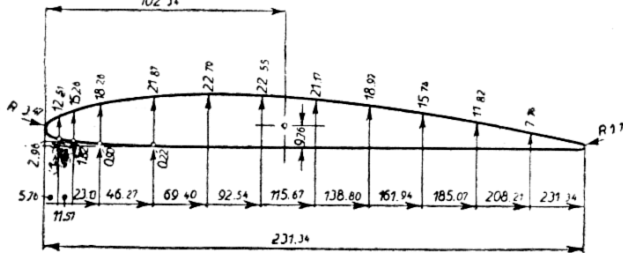

Sez. ⑥ Camp. 4.62

Incl.  $50^{\circ}41'$   
 $s: 4900 \text{ mm}^2$

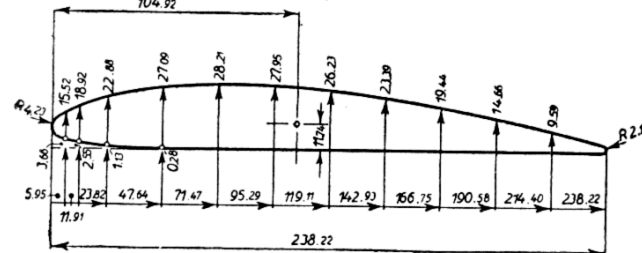

Sez. ⑦ Camp. 3.85

Incl.  $56^{\circ}58'$   
 $s: 5900 \text{ mm}^2$

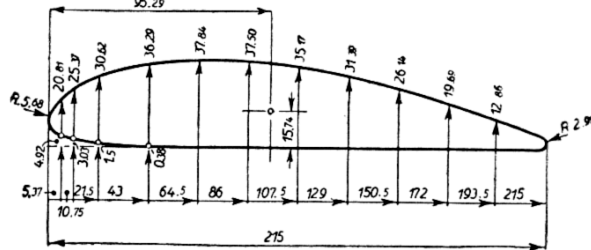

Sez. ⑧ Camp. 2.3

Incl.  $61^{\circ}44'$   
 $s: 6630 \text{ mm}^2$

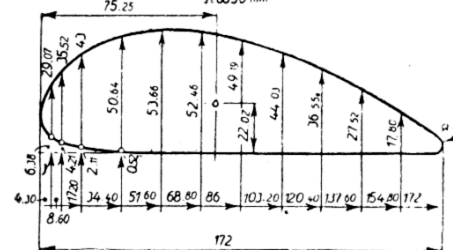



# Seção - Fora da vista sem indicação

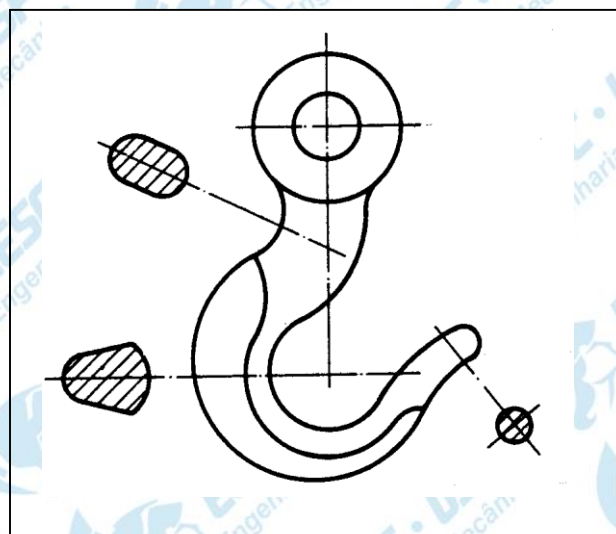
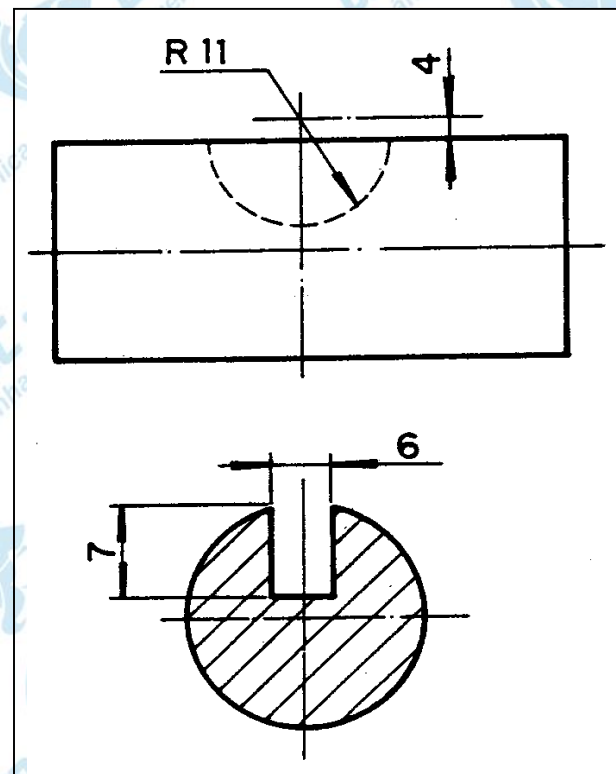
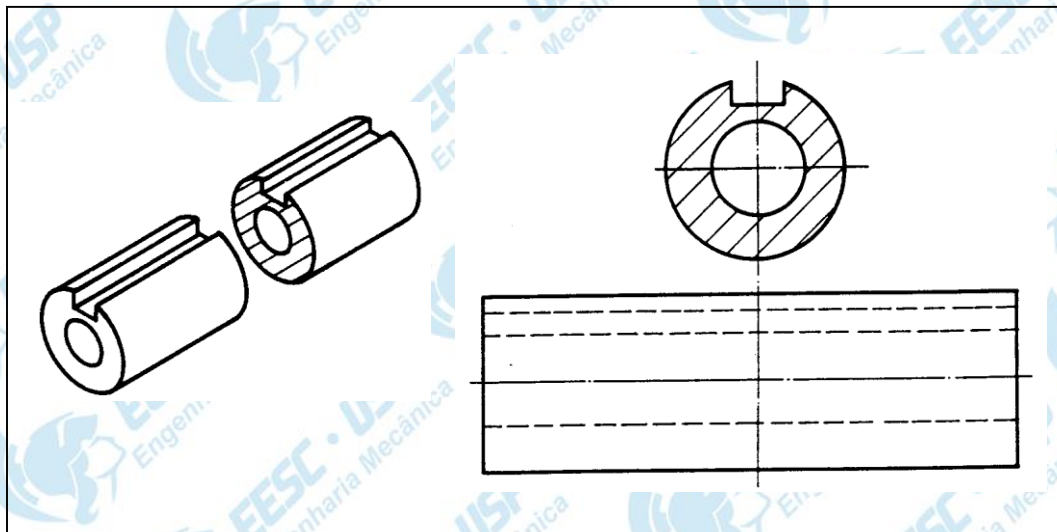

# Exemplo de Seção fora da vista sem indicação

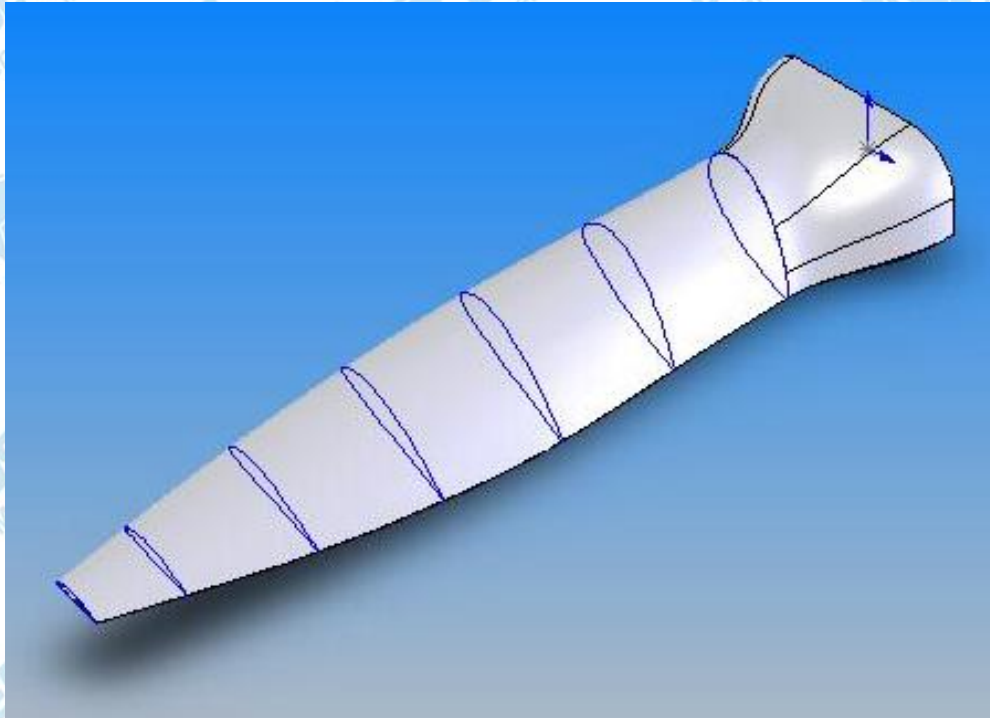

Tip Section

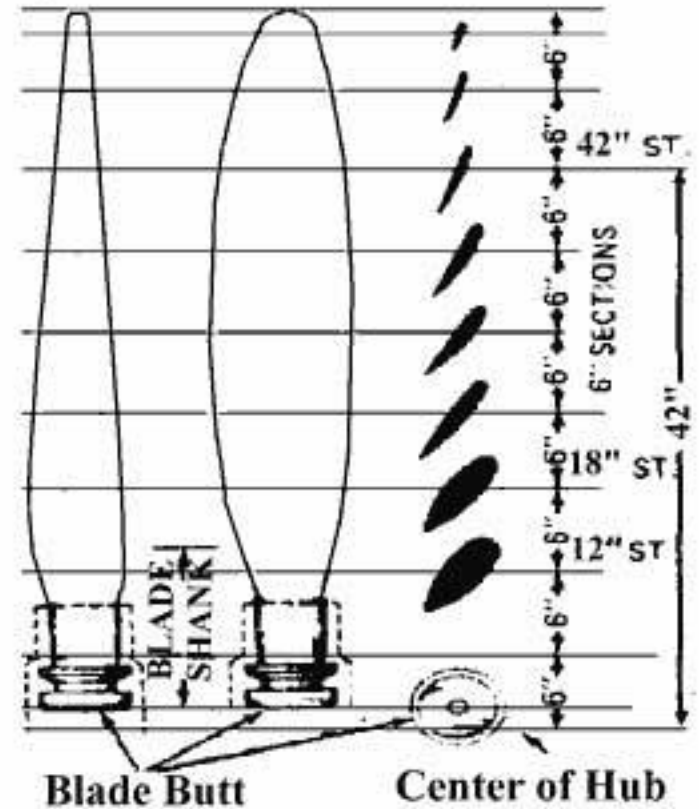

# Seção sobreposta à vista

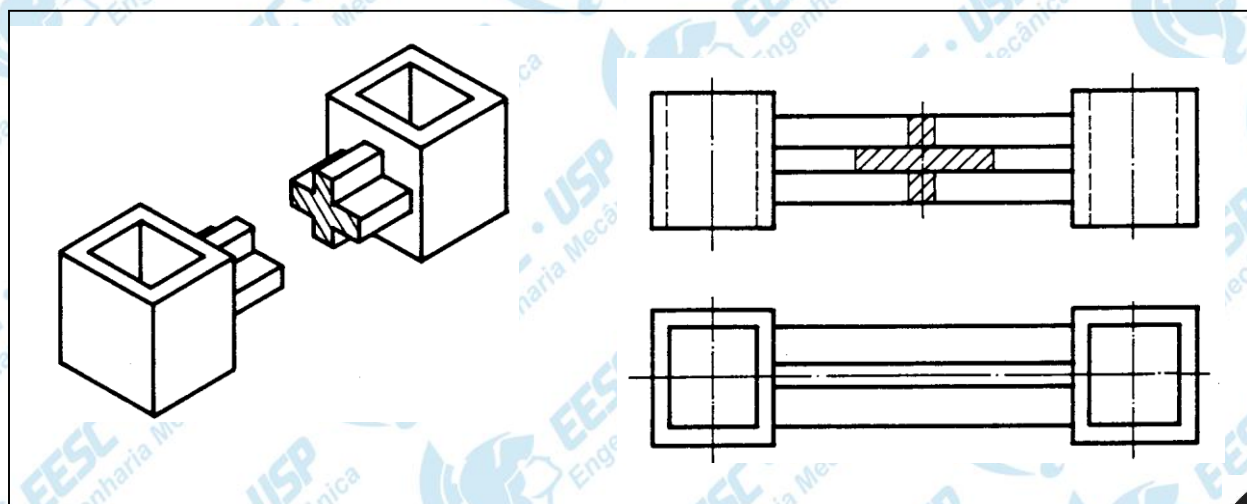
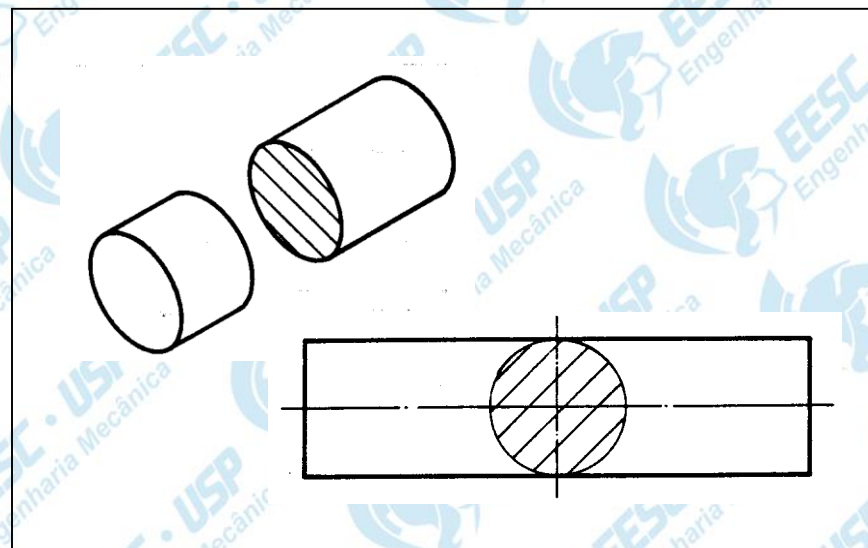
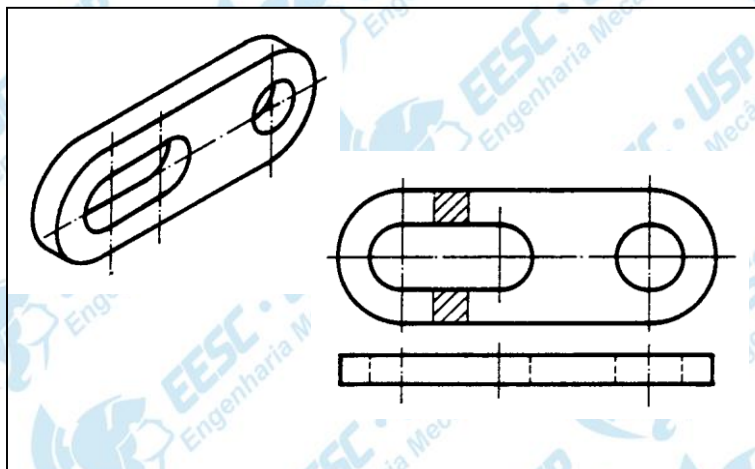

# Seção sobreposta à vista

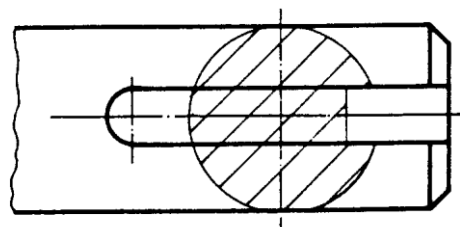
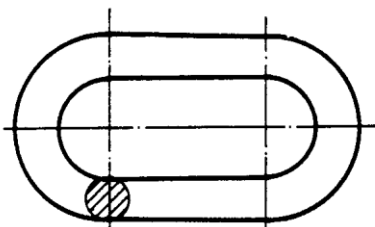
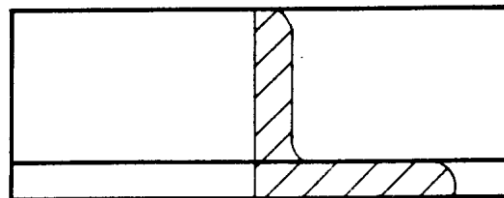
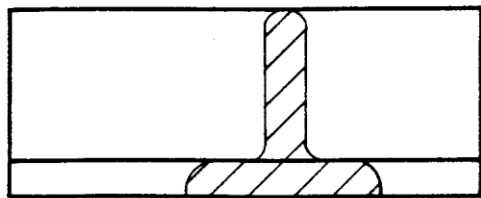

# Exemplo de seção sobreposta a vista.

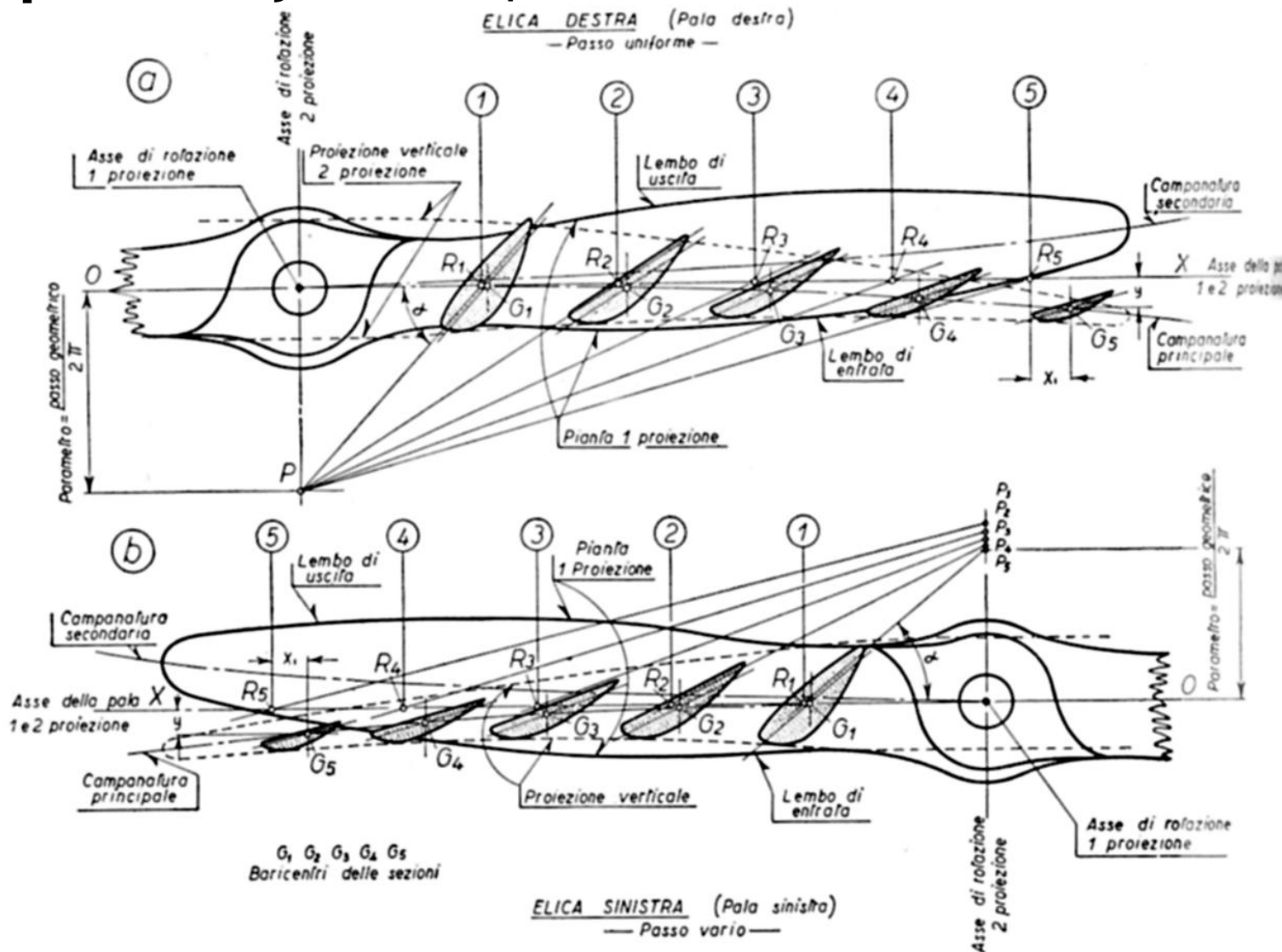

# Seção na interrupção da vista

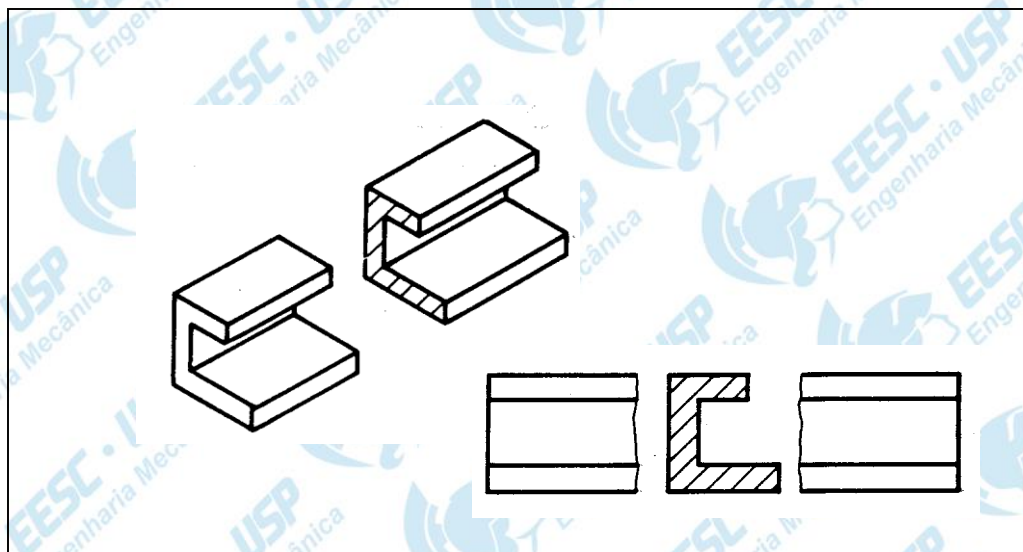
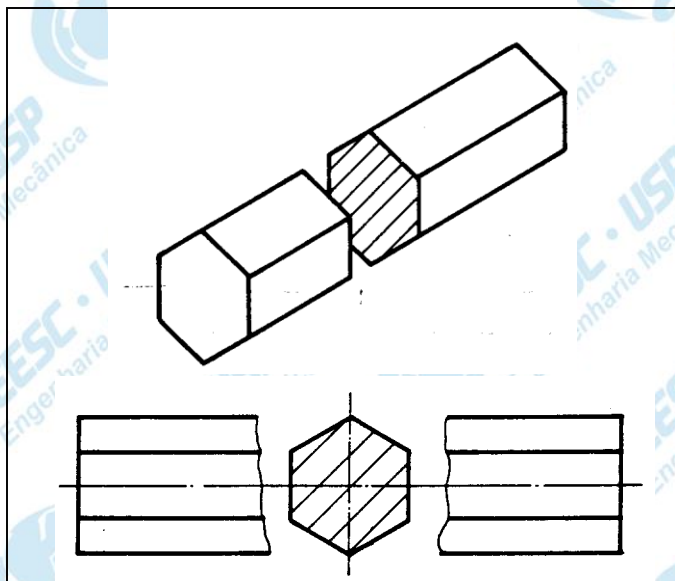
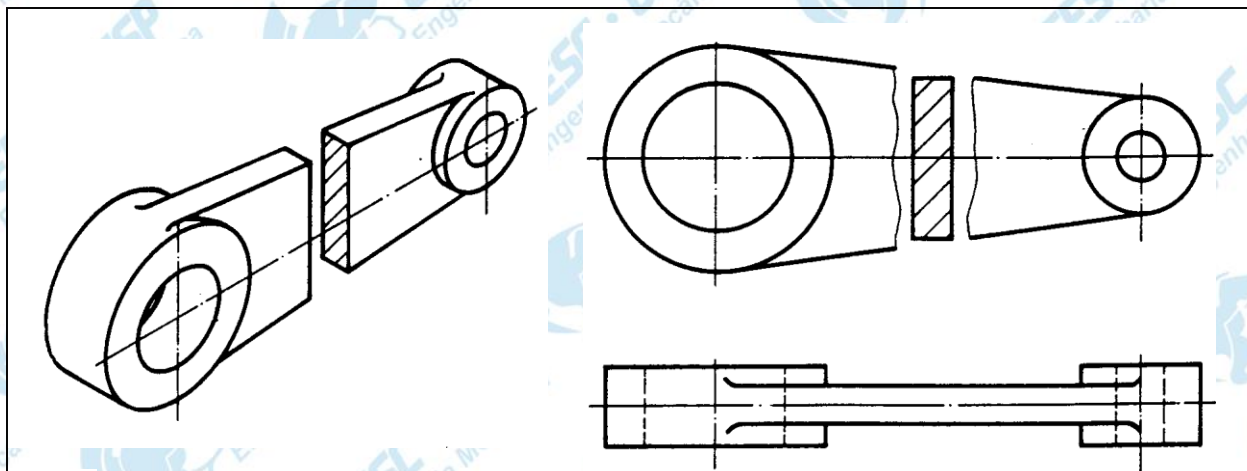

# Elementos de Máquinas - glossário

São componentes mecânicos básicos empregados na construção de máquinas. Geralmente obedecem à normas técnicas de padronização.

## Arruela

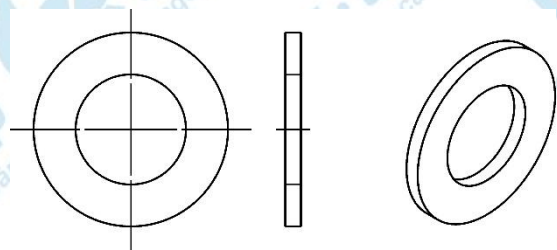

Anel achatado que interposto entre a cabeça de um parafuso e a peça diminui o atrito e distribui a pressão.

Tipos: plana, plana com chanfro, helicoidal de pressão, de segurança com lingueta,...

Quando uma peça for prevalentemente cilíndrica e tiver uma face plana, quando projetada, pode ser representada pelo cruzamento de retas (em linha estreita) pelos seus vértices.

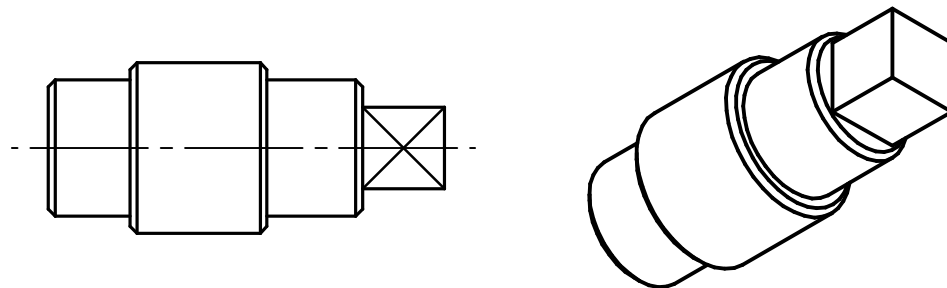

# Referências

- Leitura e Interpretação de Desenho Técnico Mecânico. Mecânica. Telecurso 2000.
- NBR 12298 – Representação de área de corte por meio de hachuras em desenho técnico. 1995
- Leitura e Interpretação de Desenho Técnico Mecânico. Mecânica. Aula 15. Telecurso 2000.
- Silva, Dias, Sousa. Desenho Técnico Moderno. Lidel Edições Técnicas.
- Apostila Desenho Mecânico, SENAI/São Paulo, 1984.



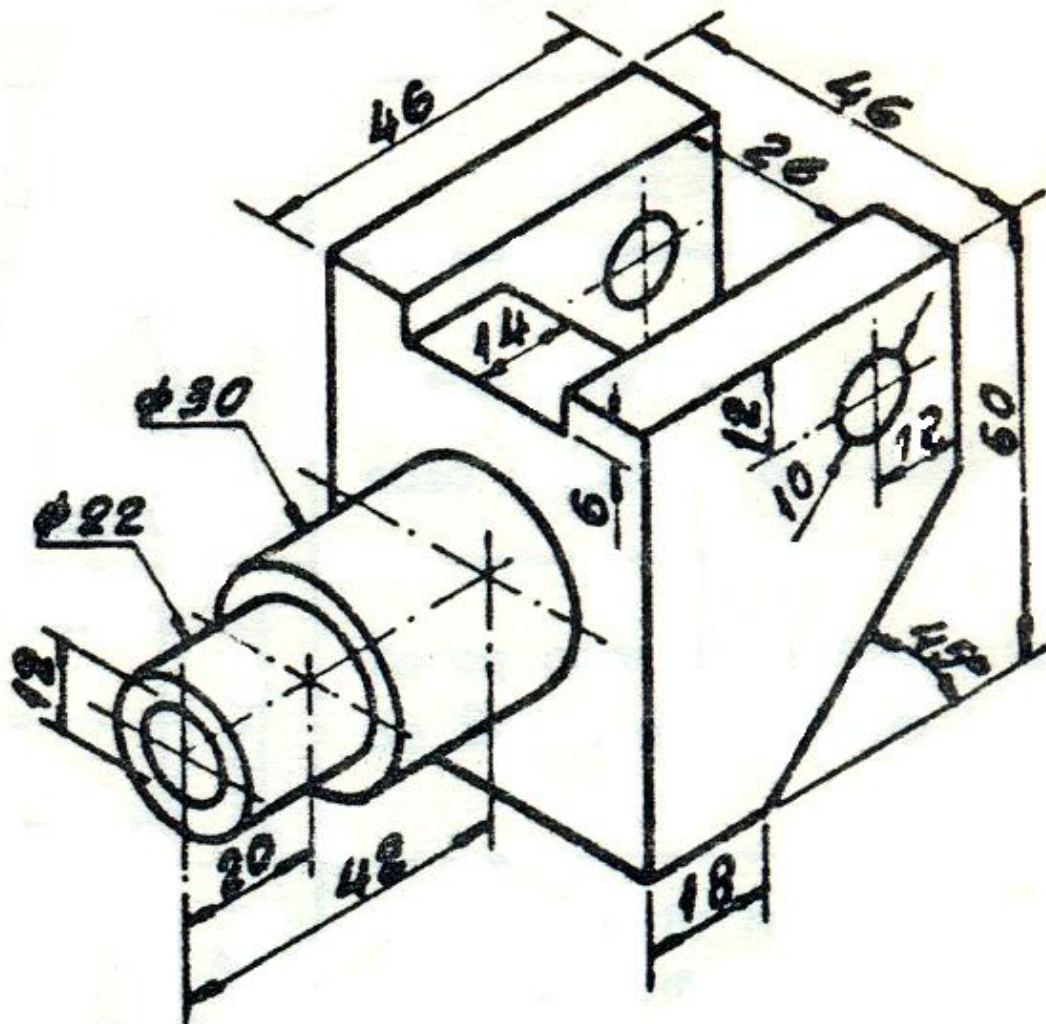

Ex. 3.01 – Faça croqui da vista frontal com corte total

Apostila Desenho Mecânico, SENAI/São Paulo, 1984

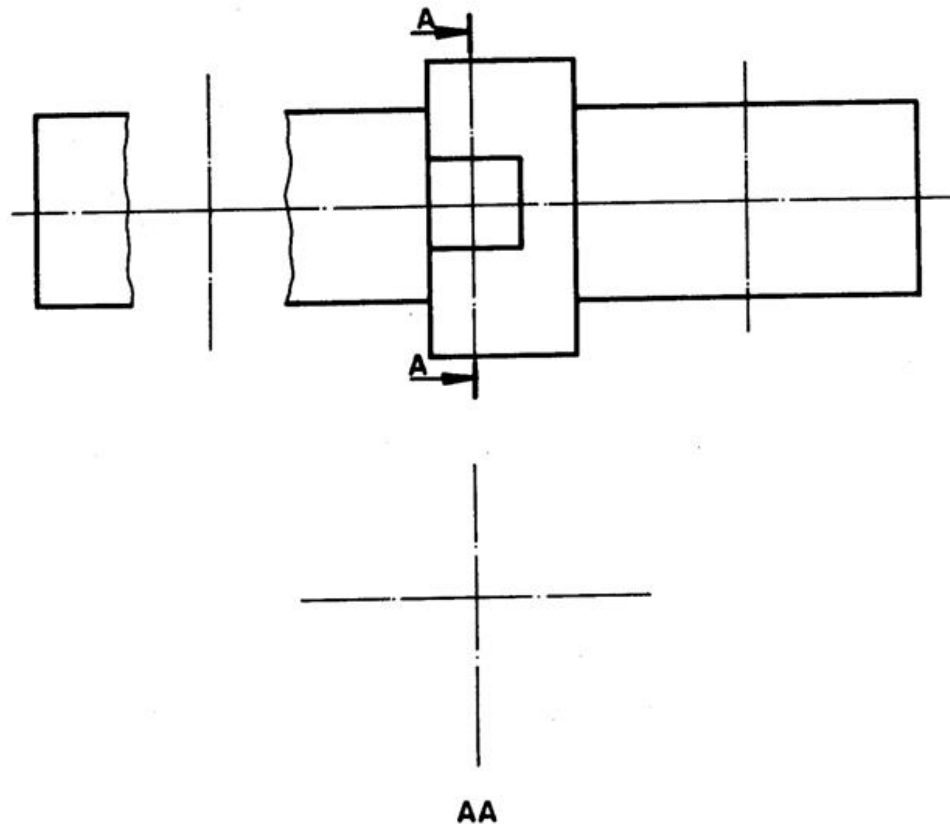
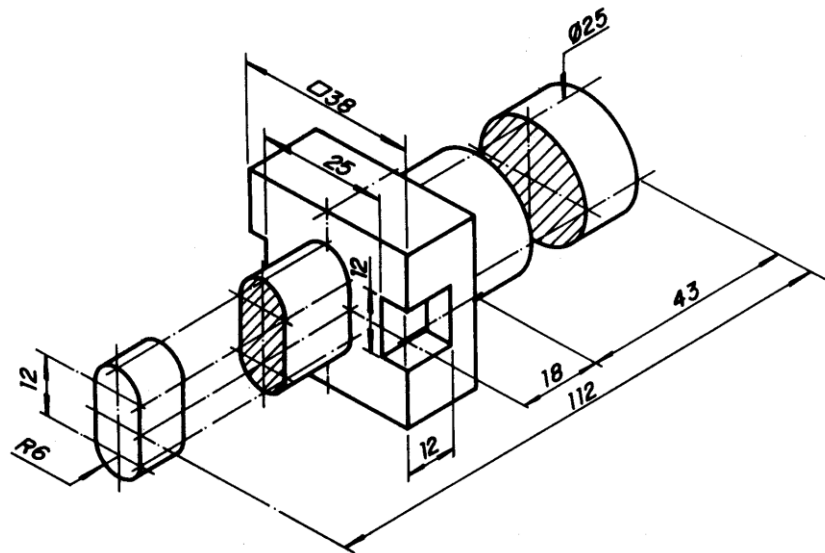

Nome: \_\_\_\_\_

Nº \_\_\_\_\_ Turma \_\_\_\_\_

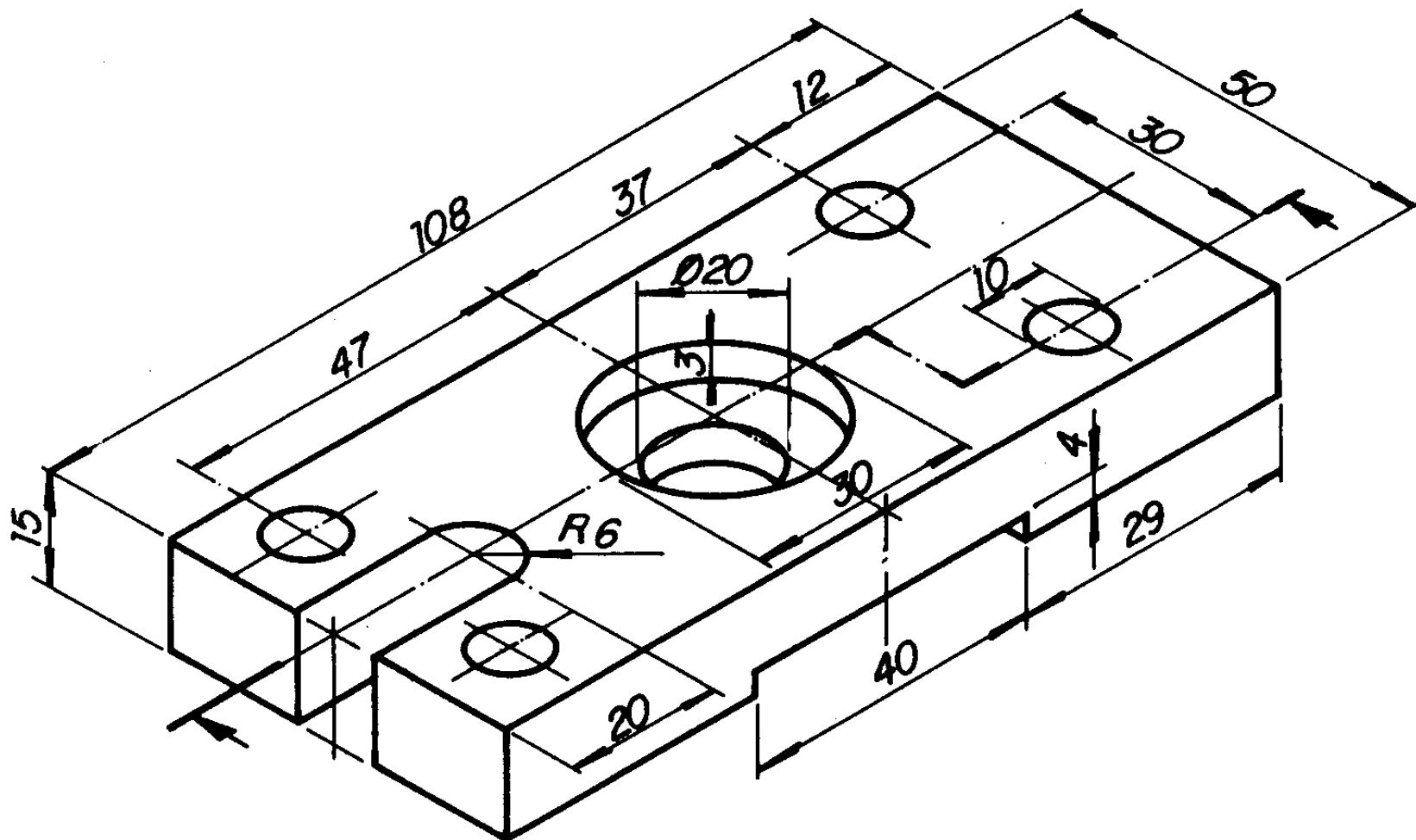

Ex. 3.03 – Desenhe a peça abaixo em duas vistas, aplicando corte composto.

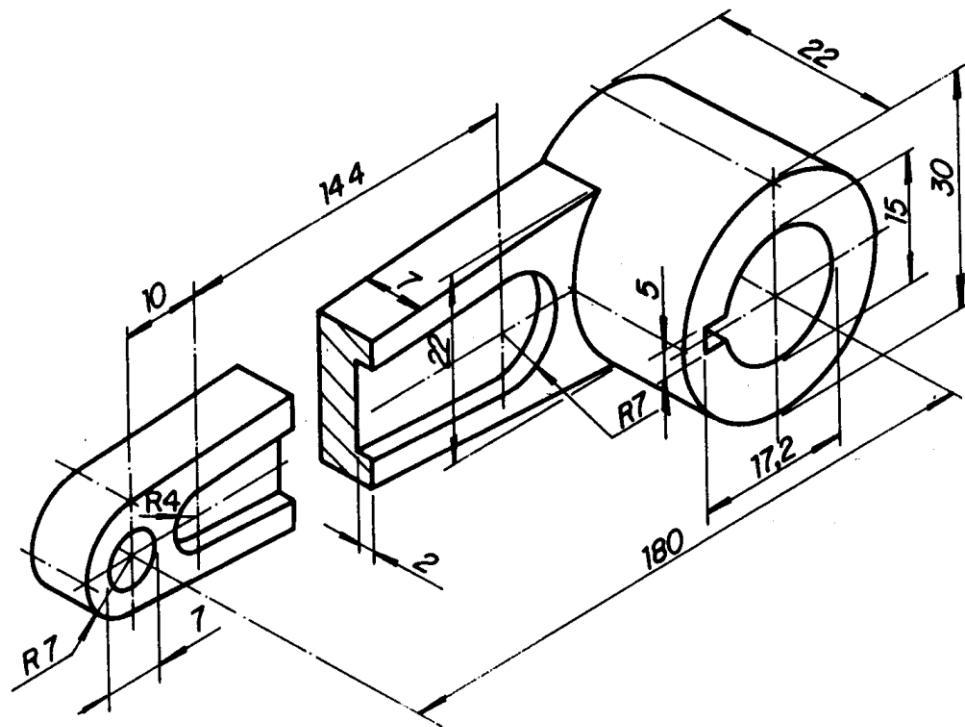

Ex. 3.04 – Desenhe as peças aplicando seção.