

SEM0104 - Aula 5

Cálculo da Velocidade: Velocidade Relativa

Prof. Dr. Marcelo Becker

SEM - EESC - USP

Prof. Dr. Marcelo Becker - SEM - EESC - USP

Sumário da Aula

Método Gráfico – Análise de Mecanismos

- **Cálculo de Velocidade**
 - Velocidade Relativa
 - Definição
 - Exemplos
- Exercícios Recomendados
- Bibliografia Recomendada

Velocidade Relativa

VR - Definição

- O Método da Velocidade Relativa emprega somas vetoriais de velocidades absolutas e relativas...

$$\vec{V}_B = \vec{V}_A + \vec{V}_{B/A}$$

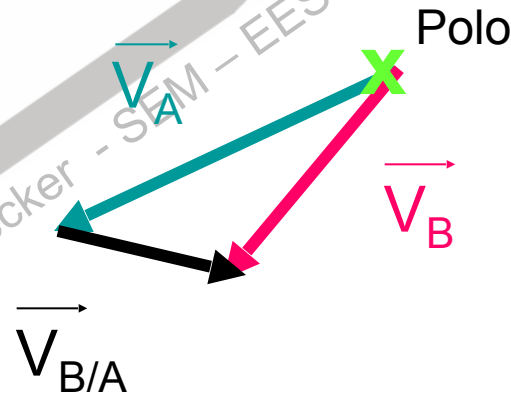

Velocidade Relativa

VR

- Exemplos

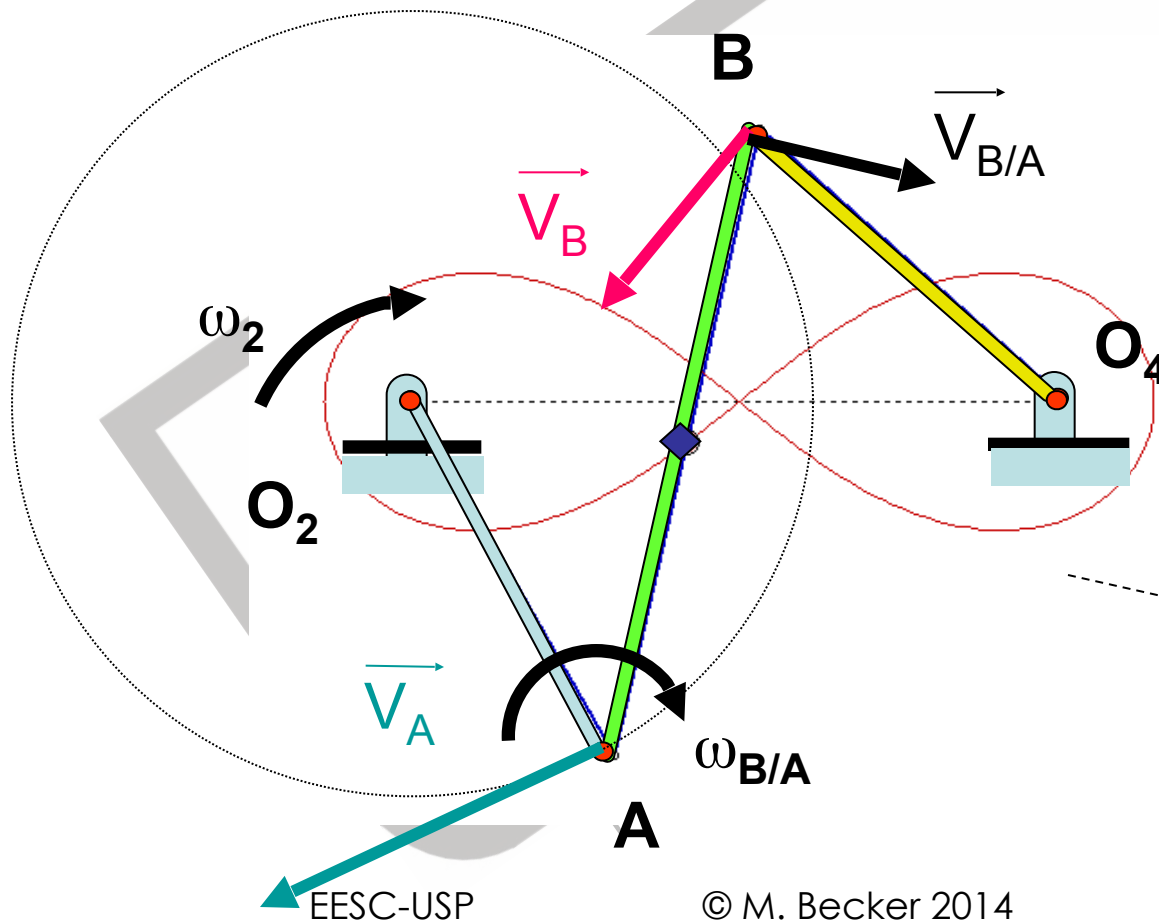

$$\vec{V}_B = \vec{V}_A + \vec{V}_{B/A}$$

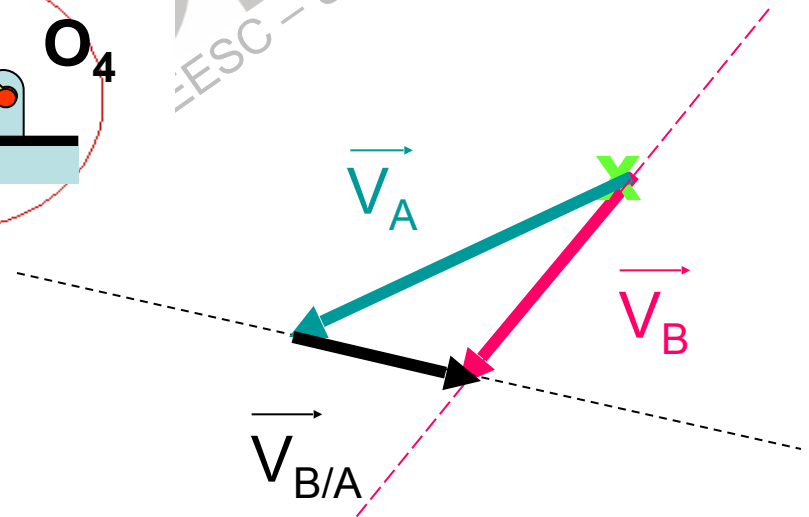

Velocidade Relativa

VR

- Exemplos

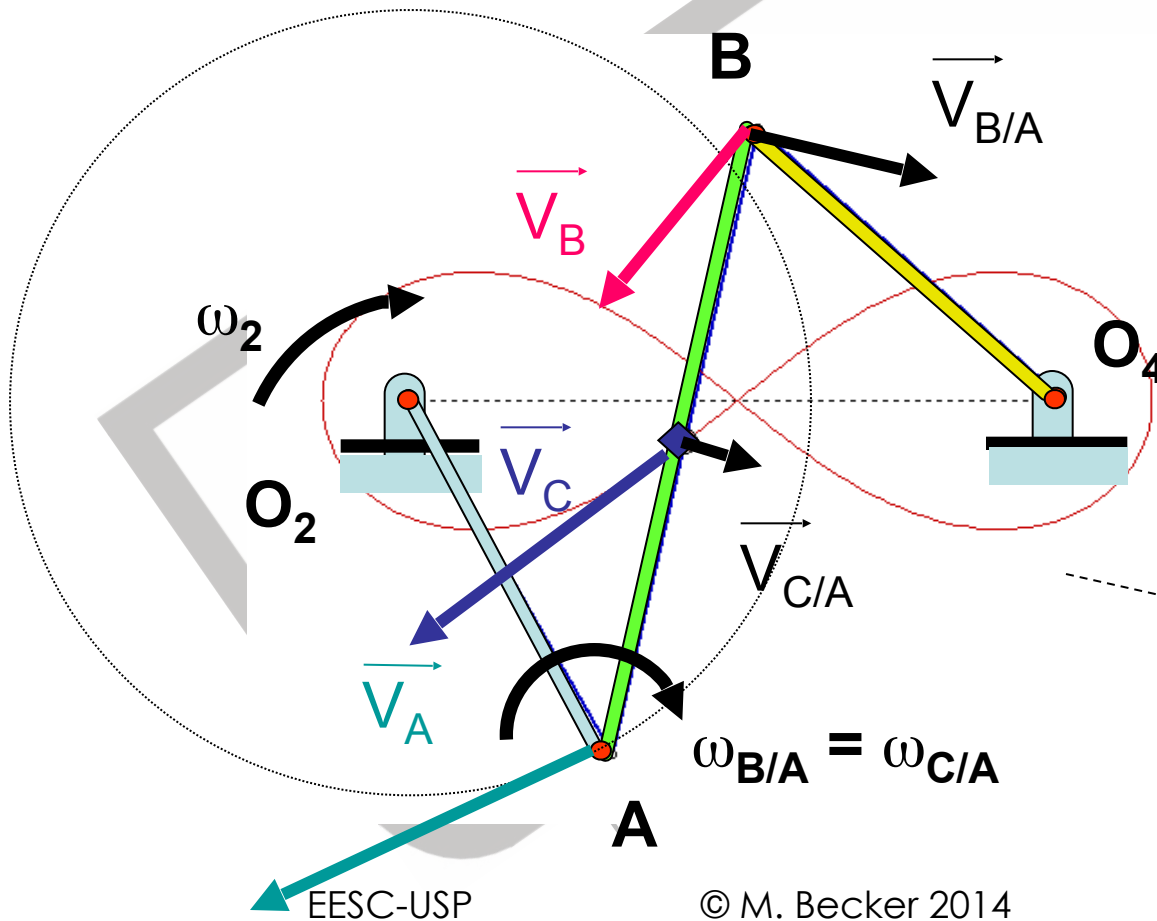

$$\vec{V}_C = \vec{V}_A + \vec{V}_{C/A}$$

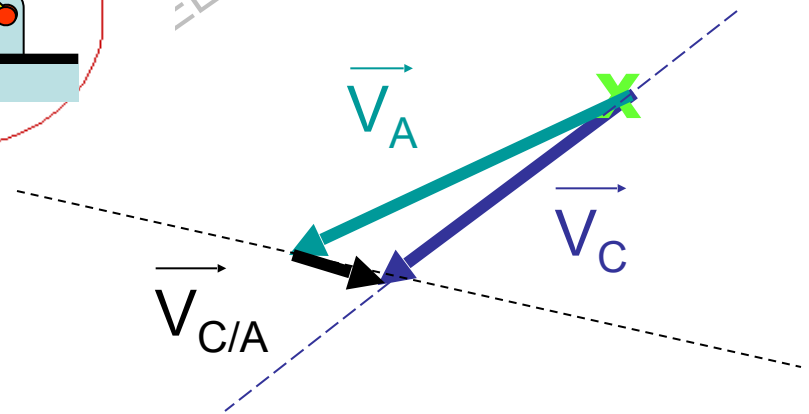

Velocidade Relativa

VR

- Chebyshev

$$\vec{V}_B = \vec{V}_A + \vec{V}_{B/A}$$

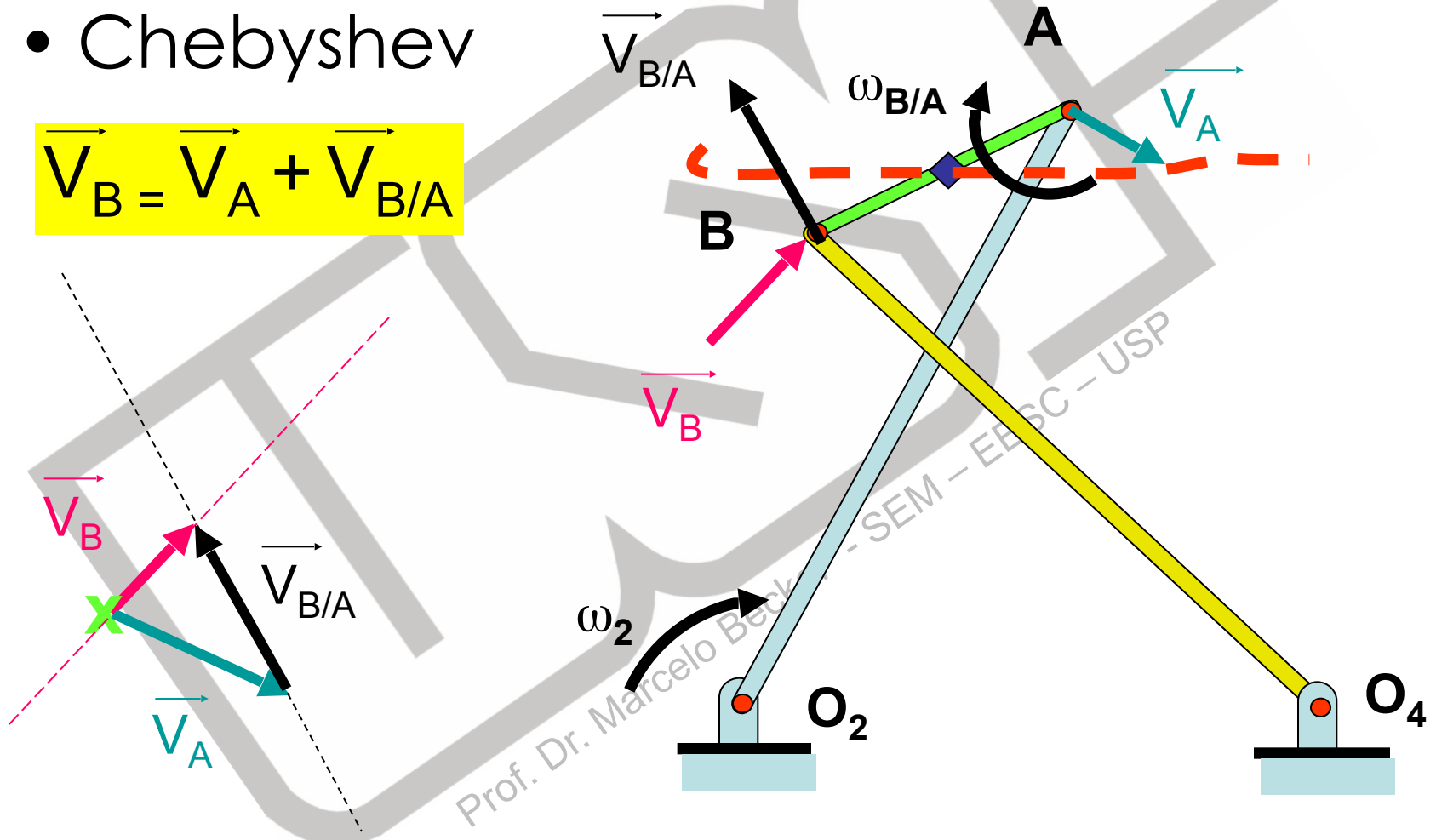

Velocidade Relativa

VR

- Chebyshev

$$\vec{V}_C = \vec{V}_A + \vec{V}_{C/A}$$

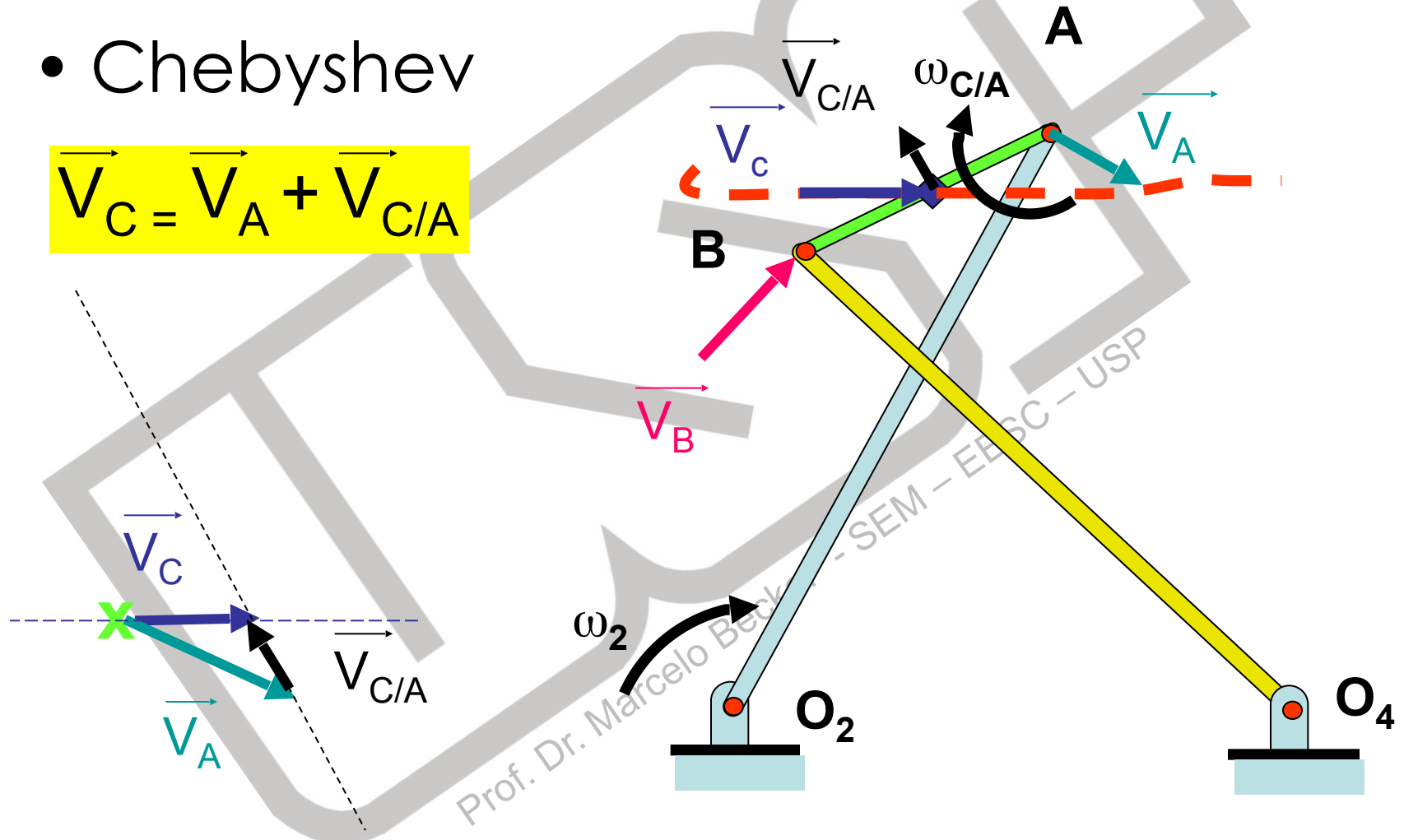

Velocidade Relativa

VR

$$\vec{V}_B = \vec{V}_A + \vec{V}_{B/A}$$

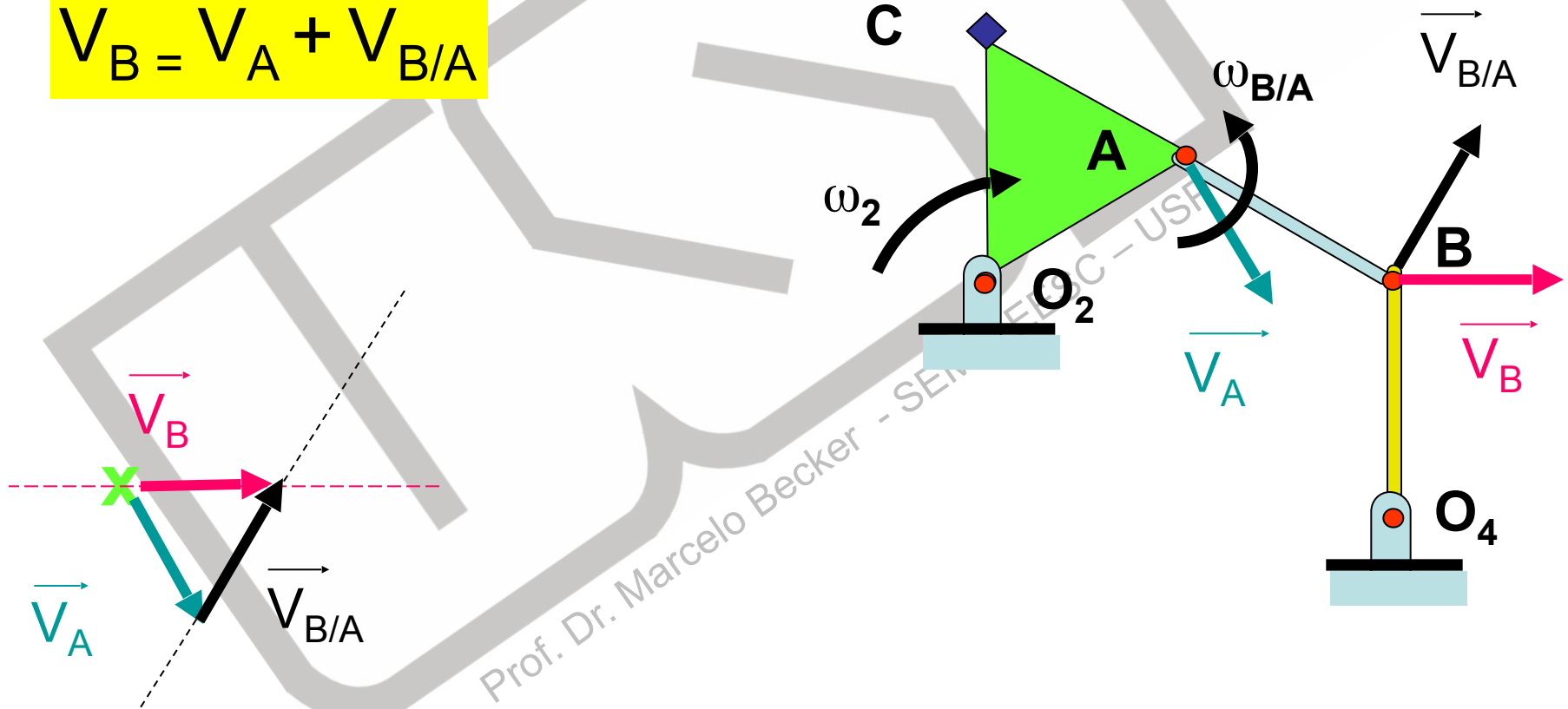

Velocidade Relativa

VR

$$\vec{V}_C = \vec{\omega}_2 \times \vec{O}_2C$$

$$\vec{V}_C = \vec{V}_A + \vec{V}_{C/A}$$

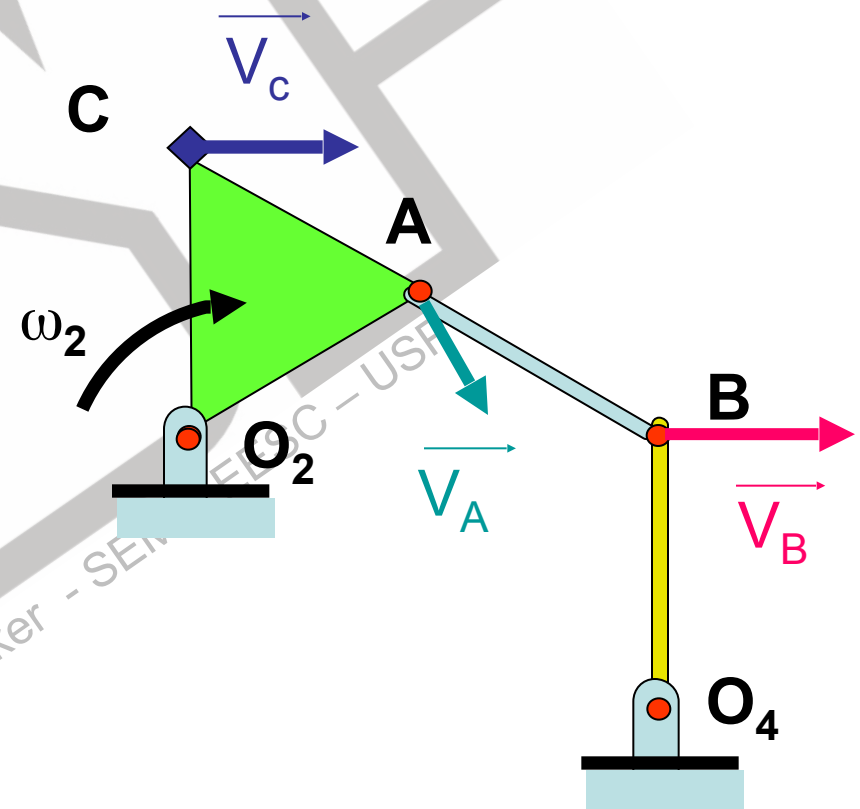
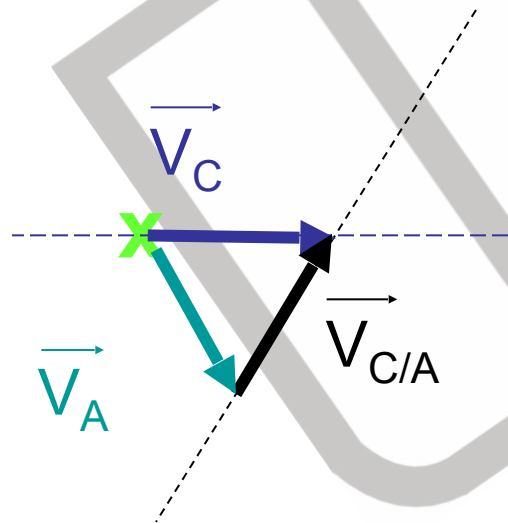

Velocidade Relativa

VR – Mecanismos Complexos

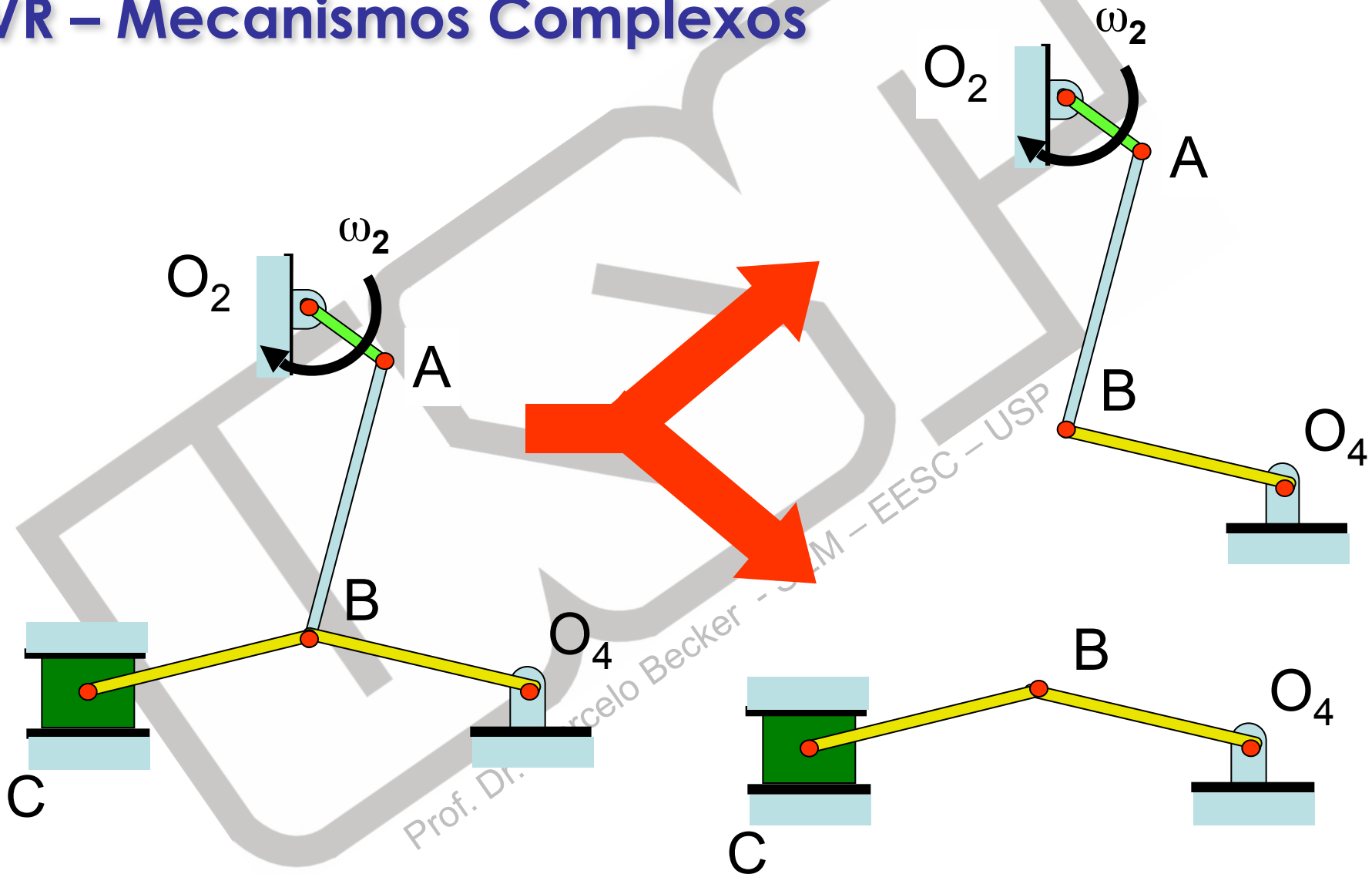

Velocidade Relativa

VR – Mecanismos Complexos

$$\vec{V}_B = \vec{V}_A + \vec{V}_{B/A}$$

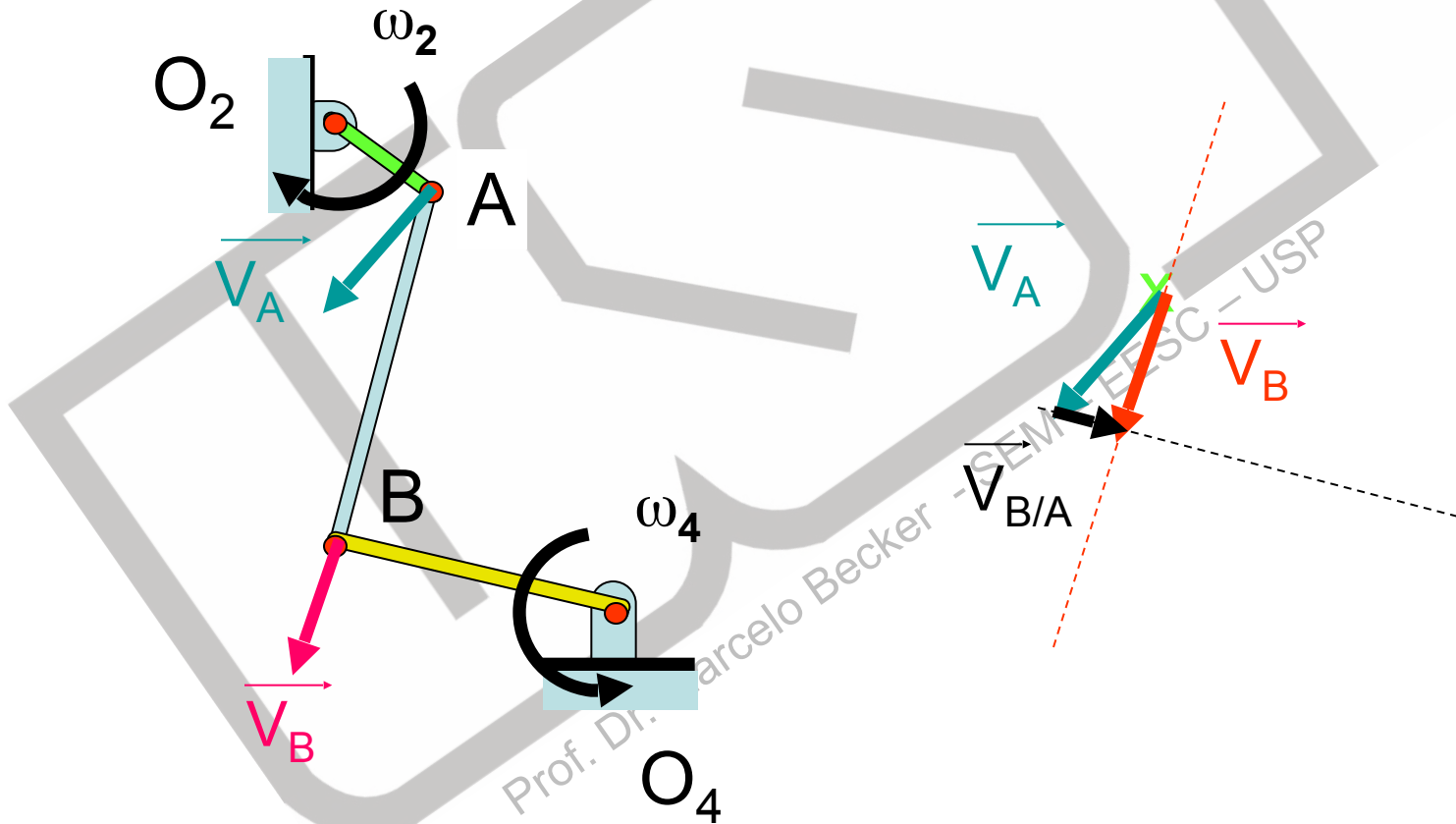

Velocidade Relativa

VR – Mecanismos Complexos

$$\vec{V}_C = \vec{V}_B + \vec{V}_{C/B}$$

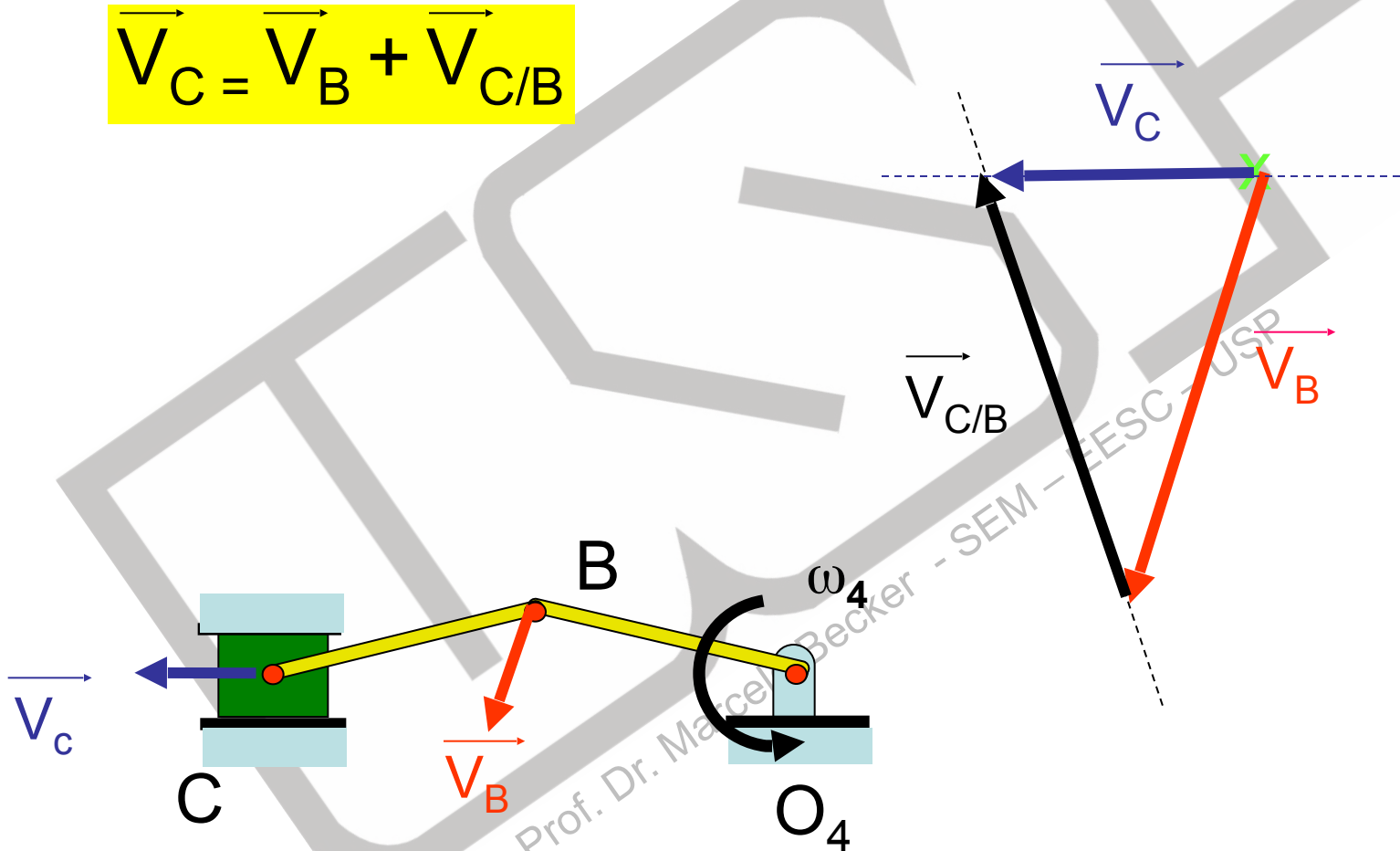

Velocidade Relativa

VR – Mecanismos Complexos

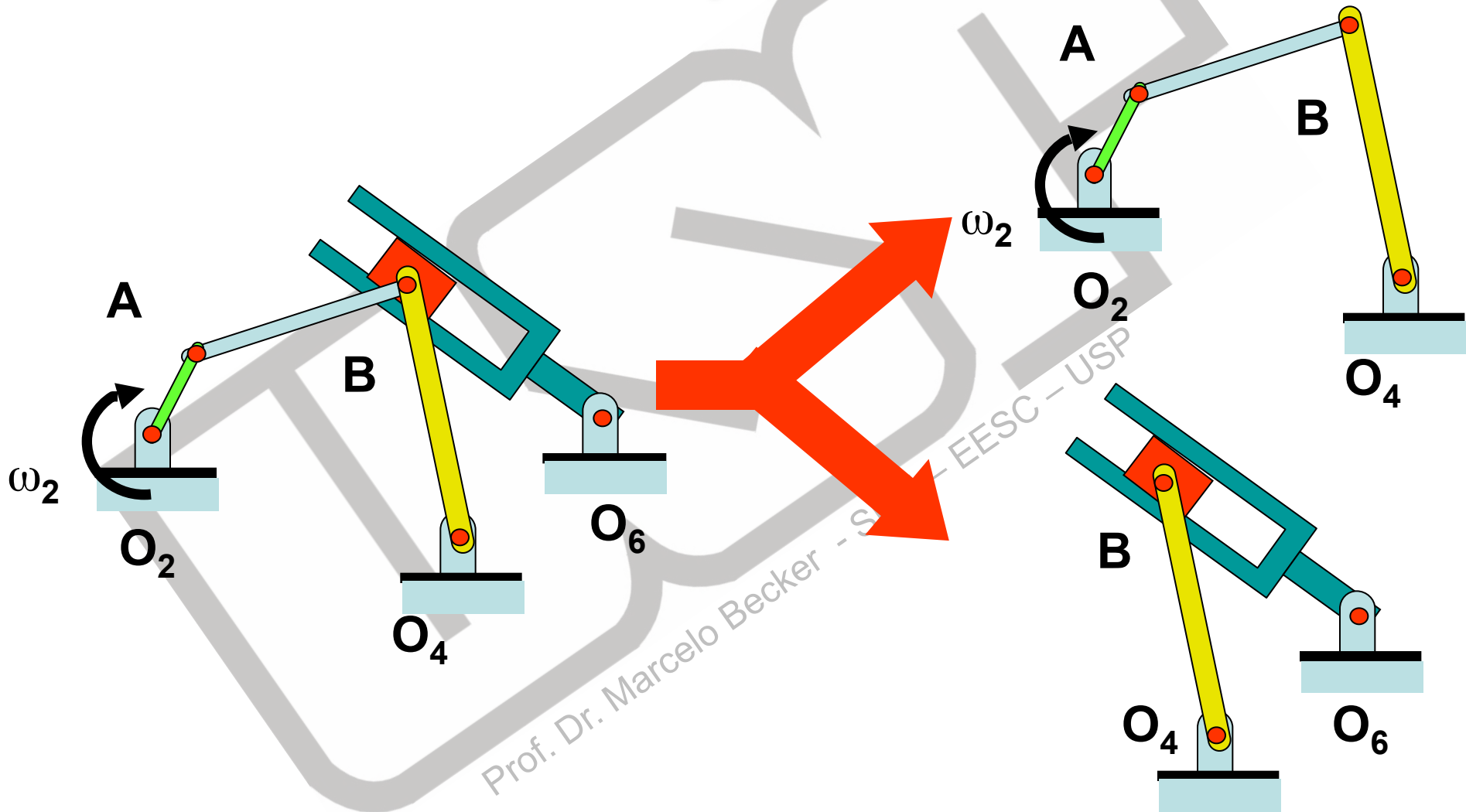

Velocidade Relativa

VR – Mecanismos Complexos

$$\vec{V}_B = \vec{V}_A + \vec{V}_{B/A}$$

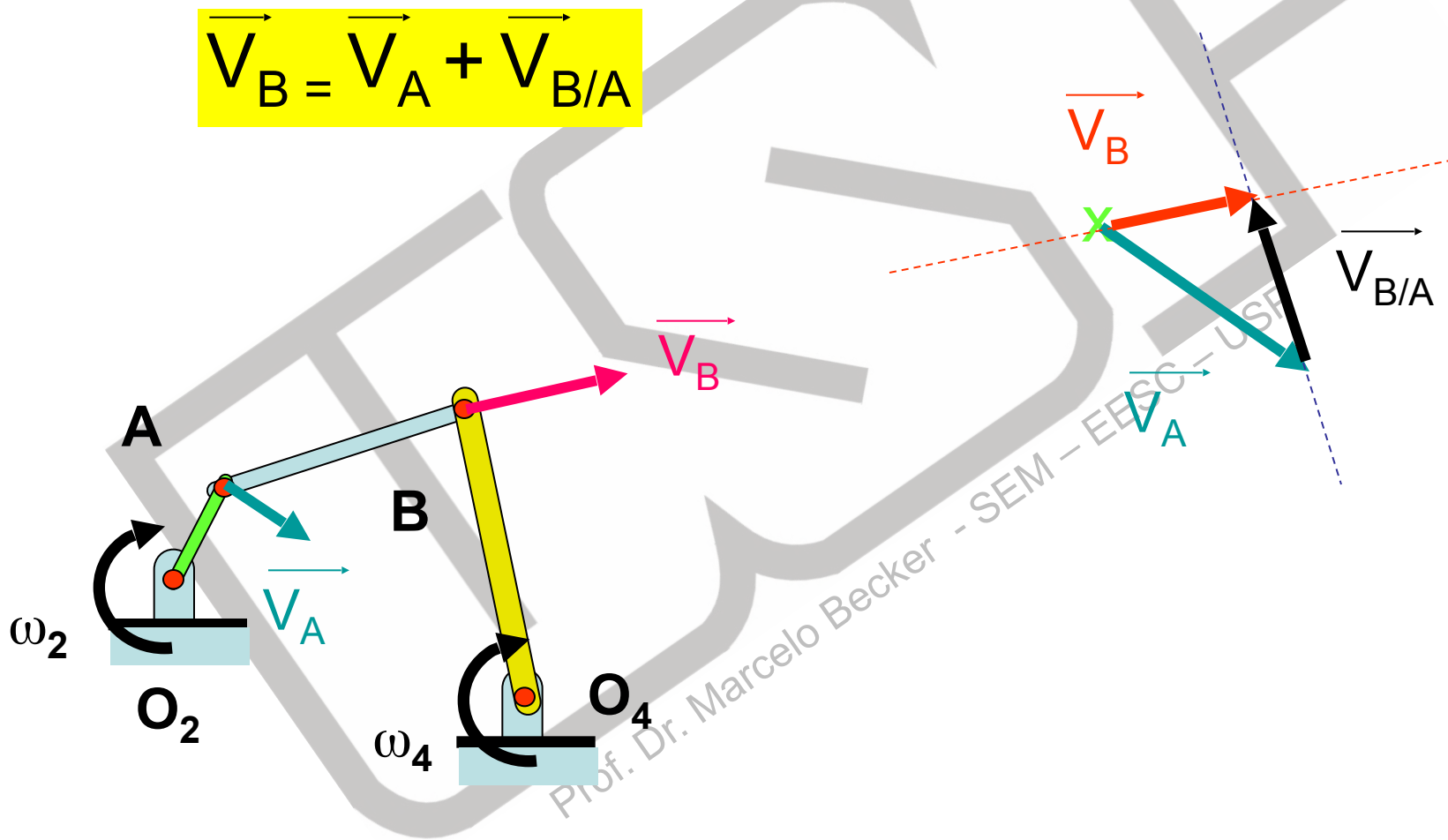

Velocidade Relativa

VR – Mecanismos Complexos

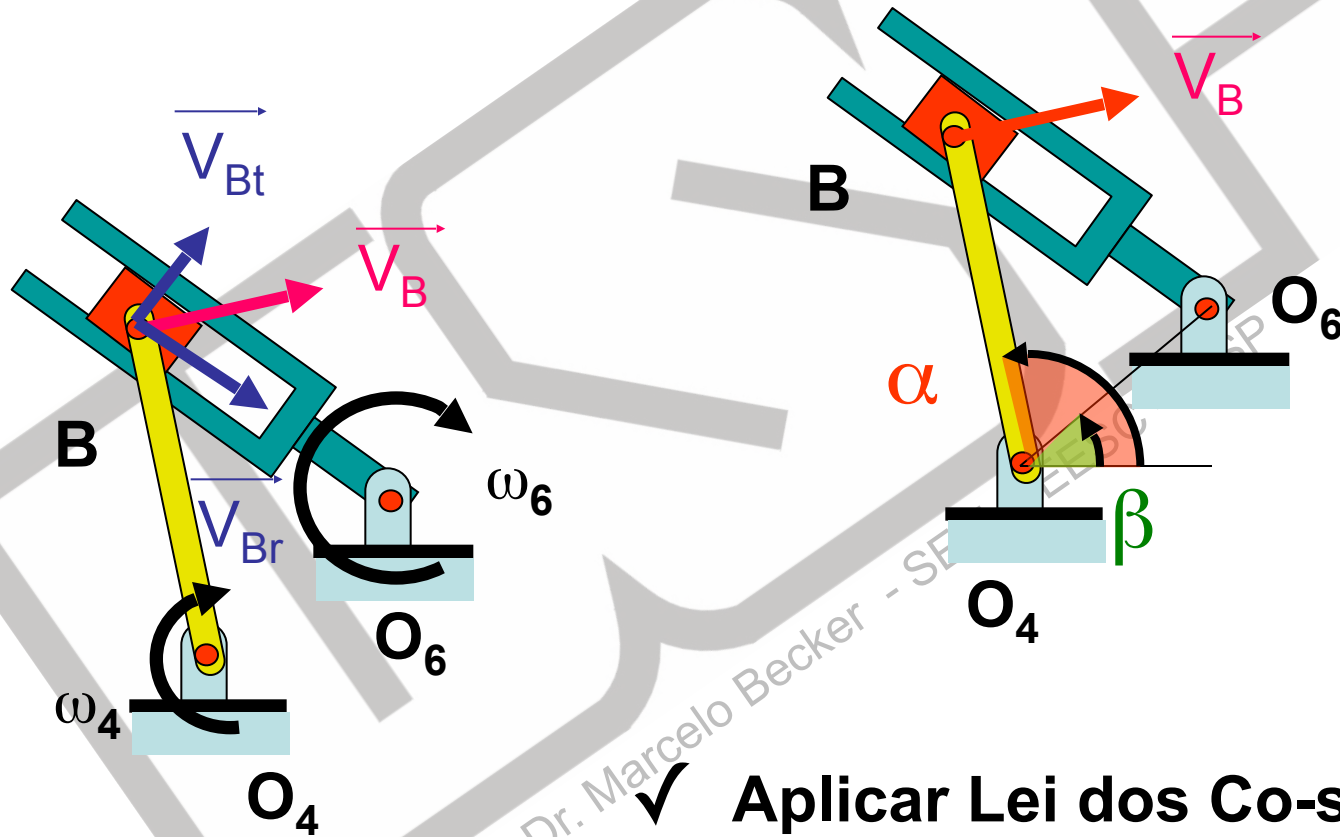

✓ Aplicar Lei dos Co-senos!!

Sumário da Aula

Método Gráfico – Análise de Mecanismos

Cálculo de Velocidade

Velocidade Relativa

Definição

Exemplos

- **Exercícios Recomendados**
- Bibliografia Recomendada

Exercícios Recomendados

1

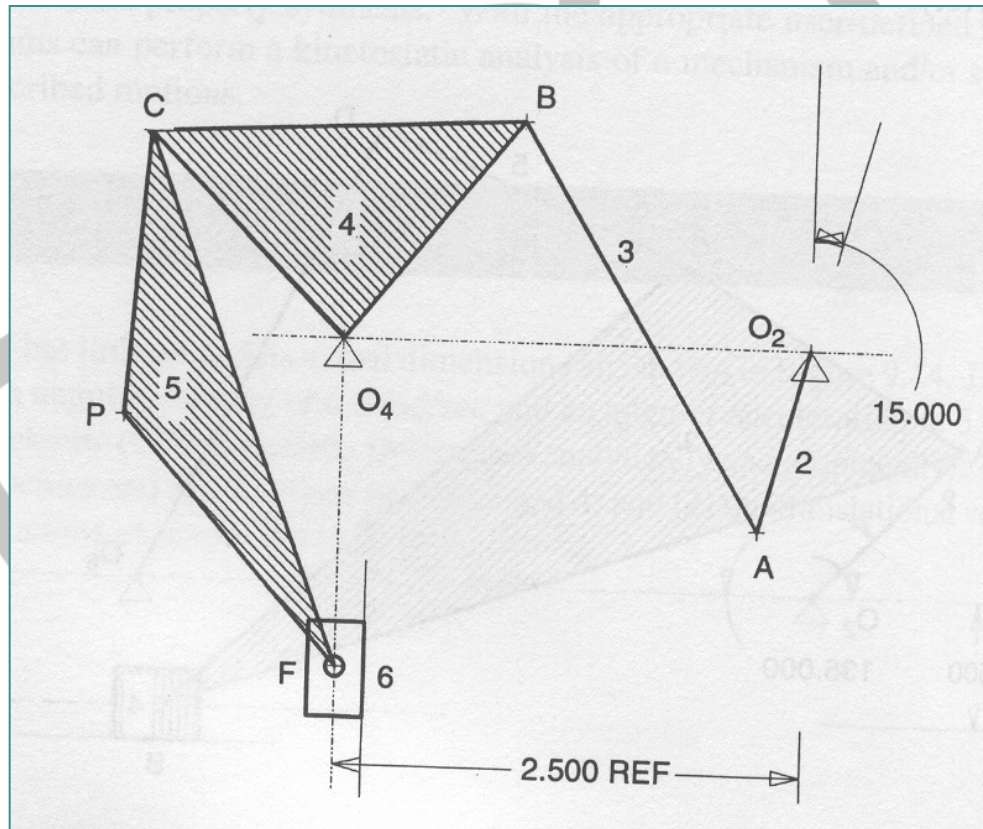

Exercícios Recomendados

2

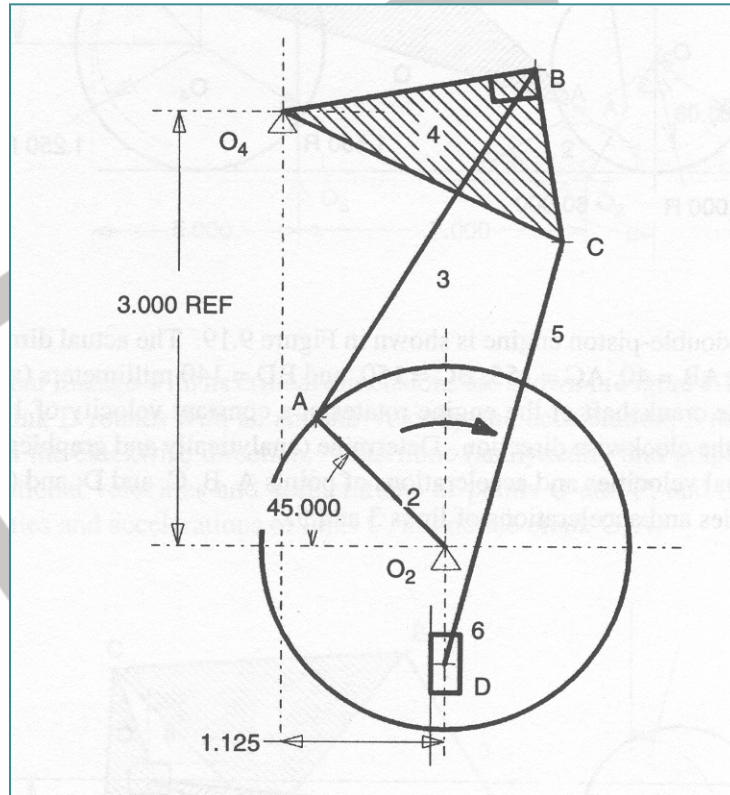

Exercícios Recomendados

3

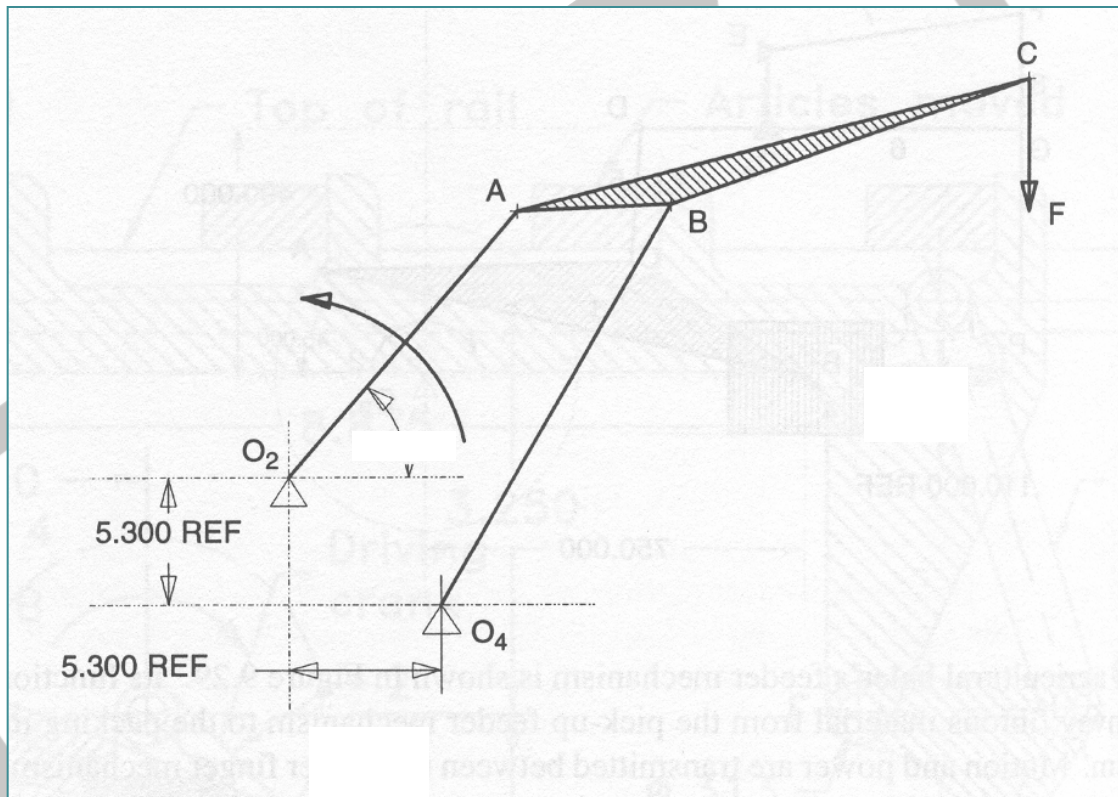

Exercícios Recomendados

4

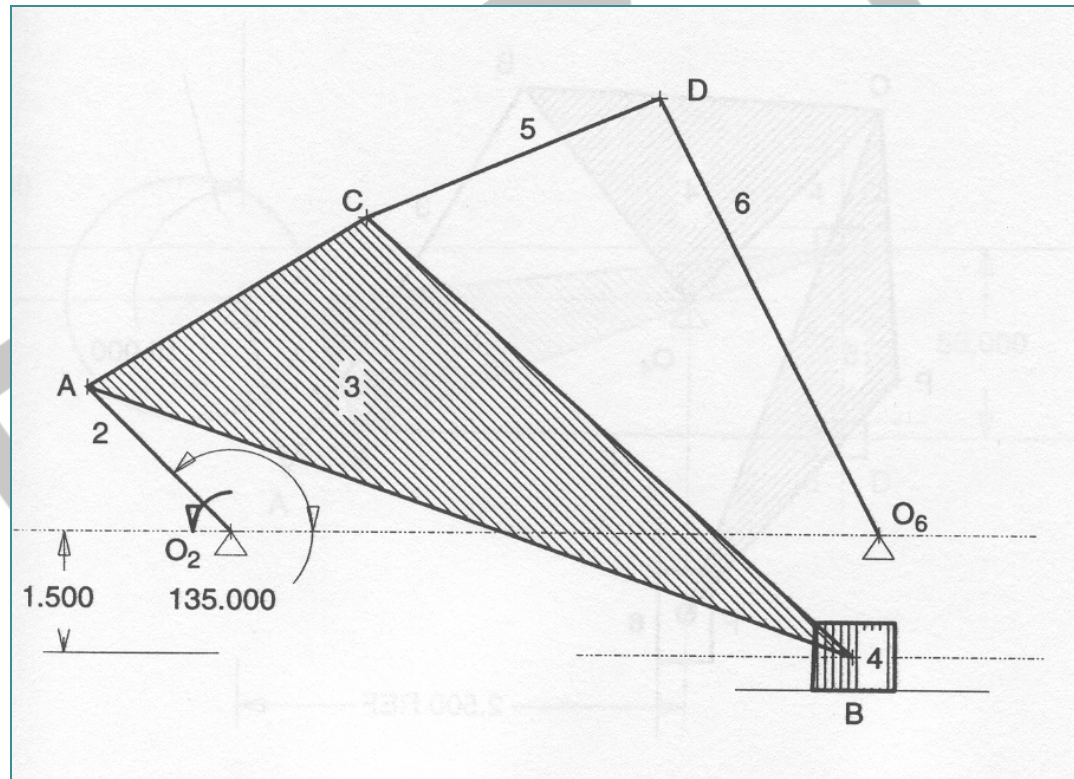

Exercícios Recomendados

5

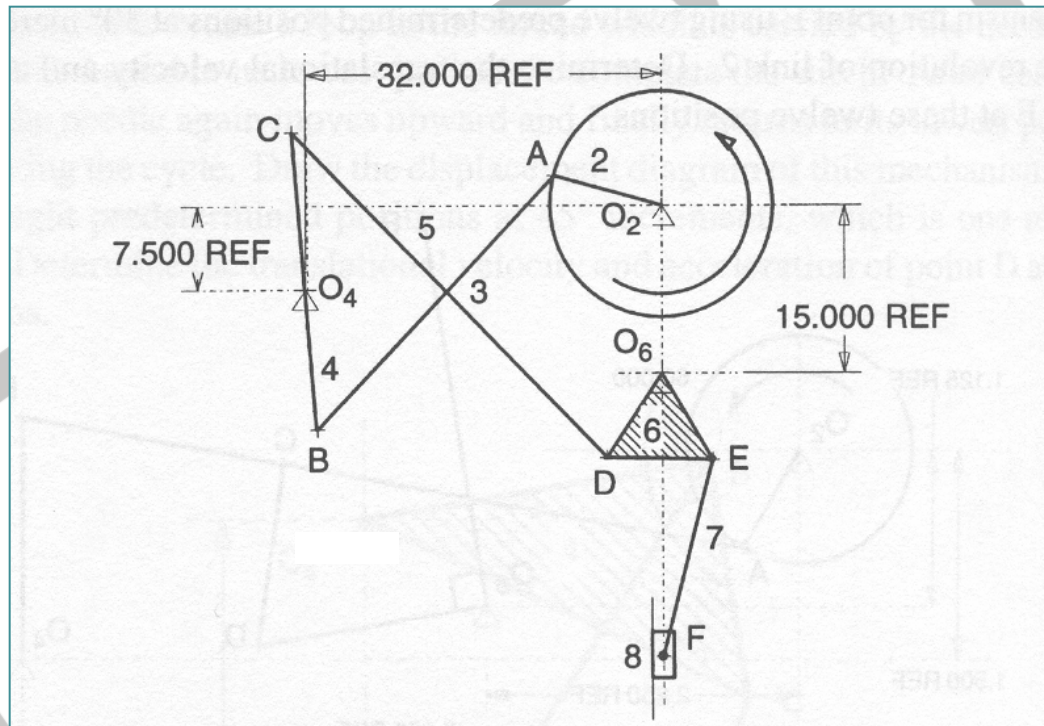

Exercícios Recomendados

6

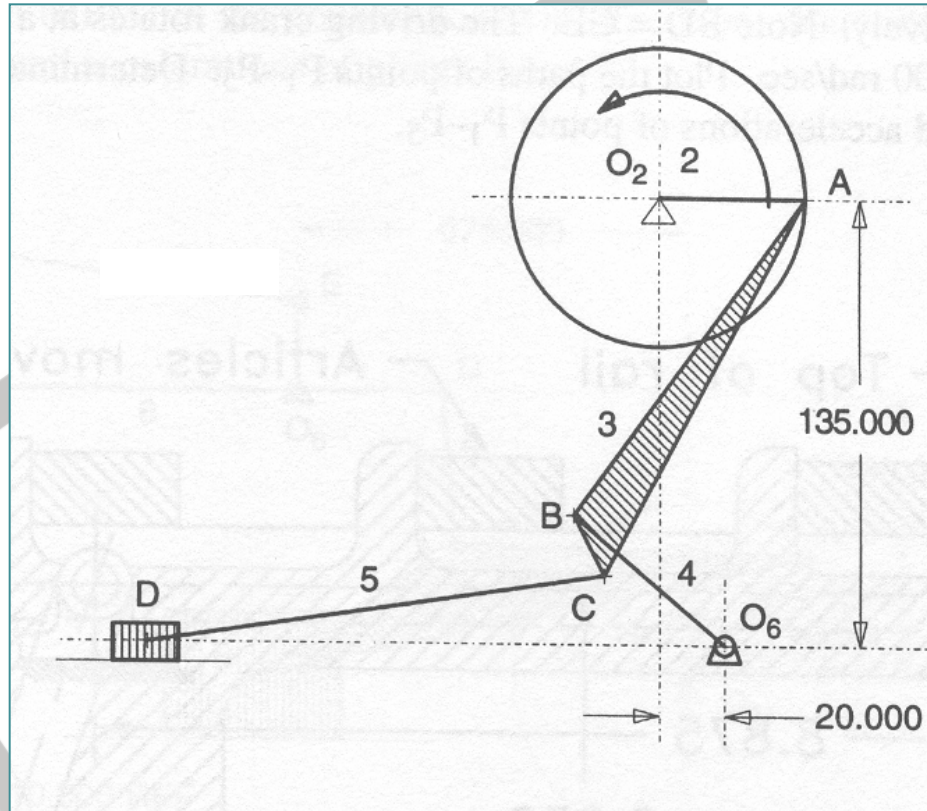

Exercícios Recomendados

7

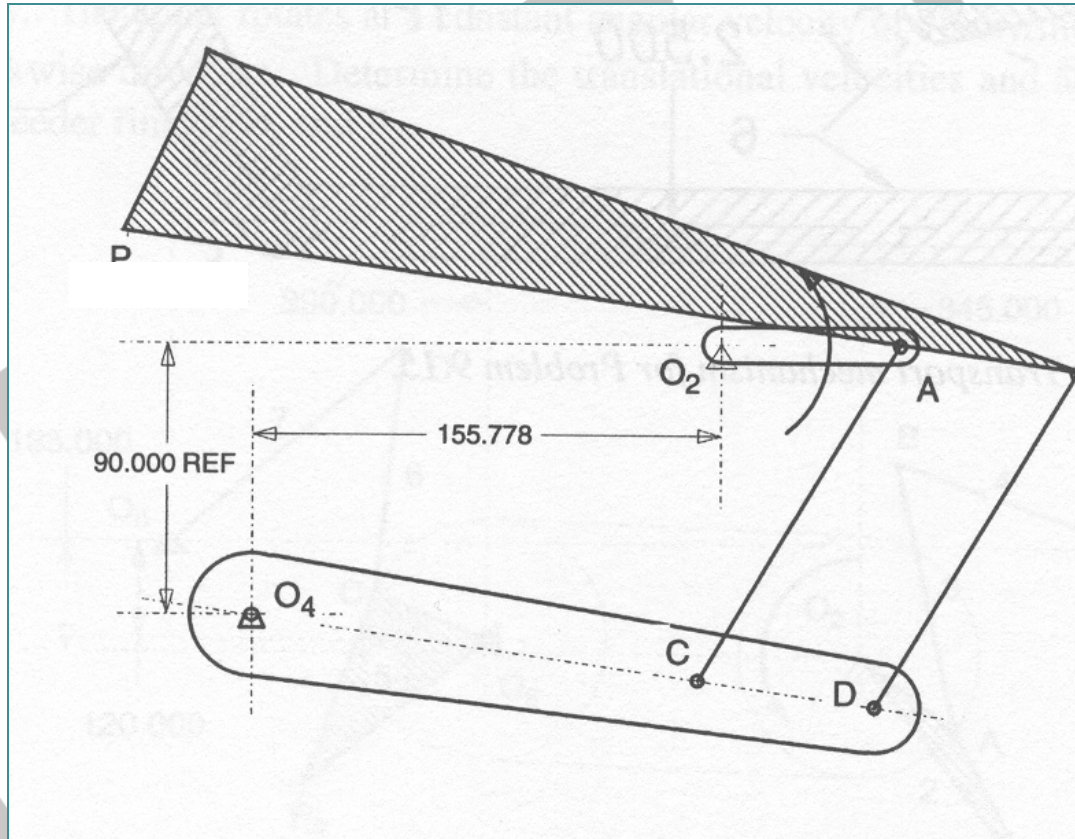

Exercícios Recomendados

8

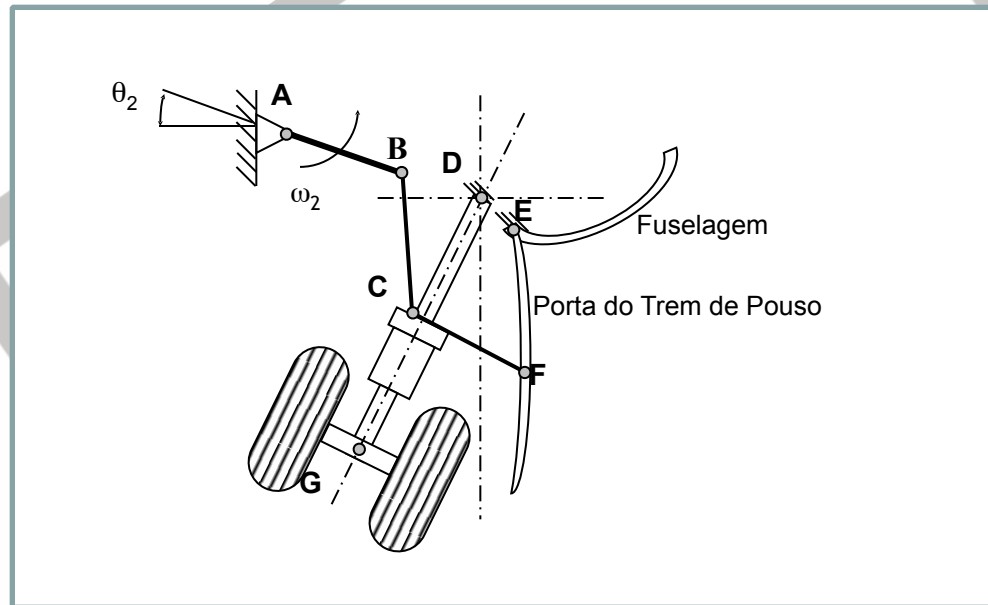

Exercícios Recomendados

9

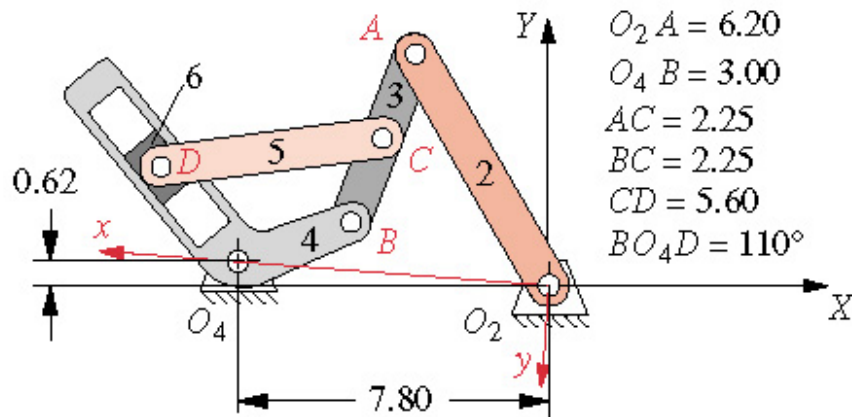

(a) Sixbar linkage

10

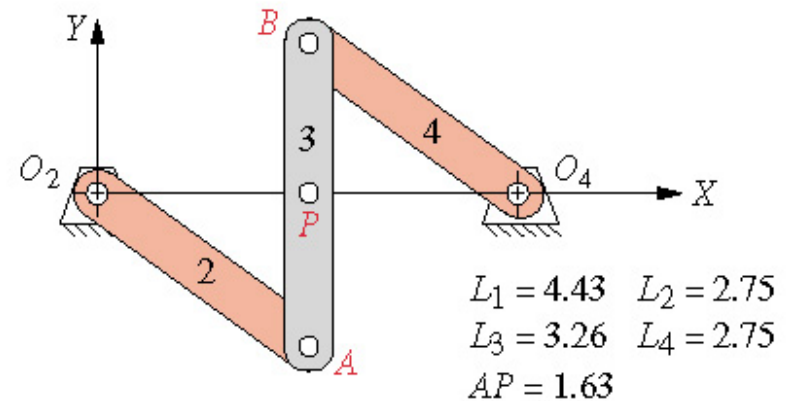

(b) Fourbar linkage

Exercícios Recomendados

11

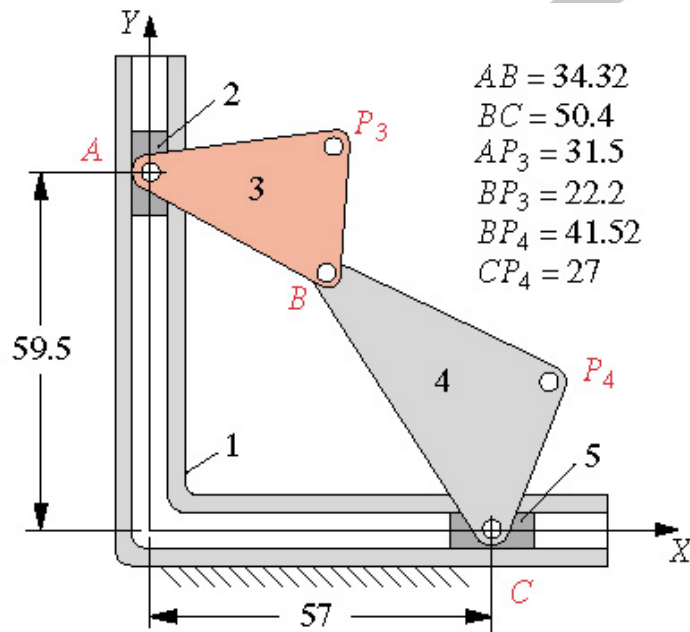

(c) Dual crosshead mechanism

12

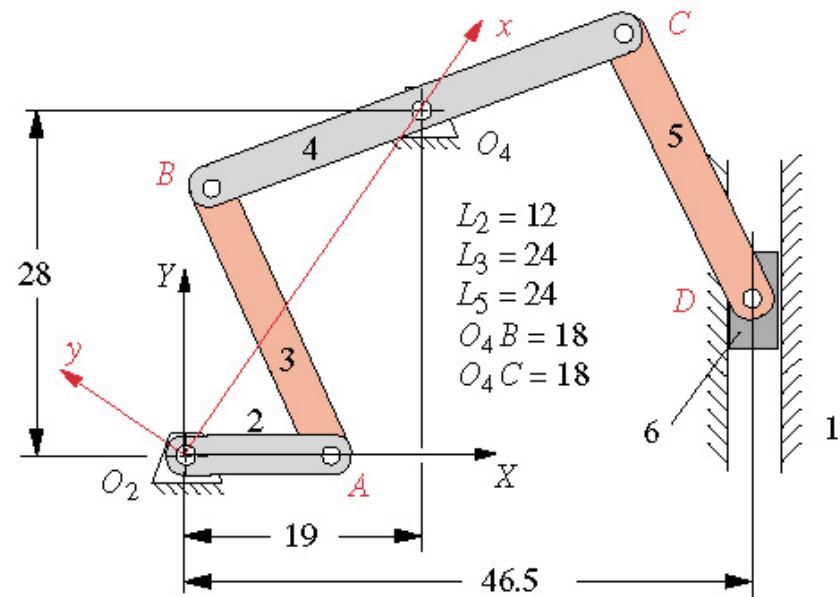

(d) Sixbar linkage

Exercícios Recomendados

13

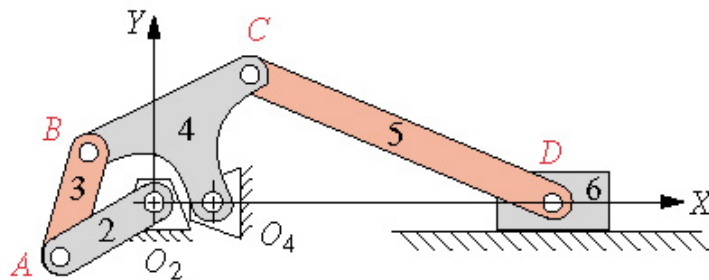

$$L_2 = 5 \quad L_3 = 5 \quad L_5 = 15 \quad BC = 8$$

$$O_2O_4 = 2.5 \quad O_4B = 6 \quad O_4C = 6$$

(e) Drag link slider-crank

14

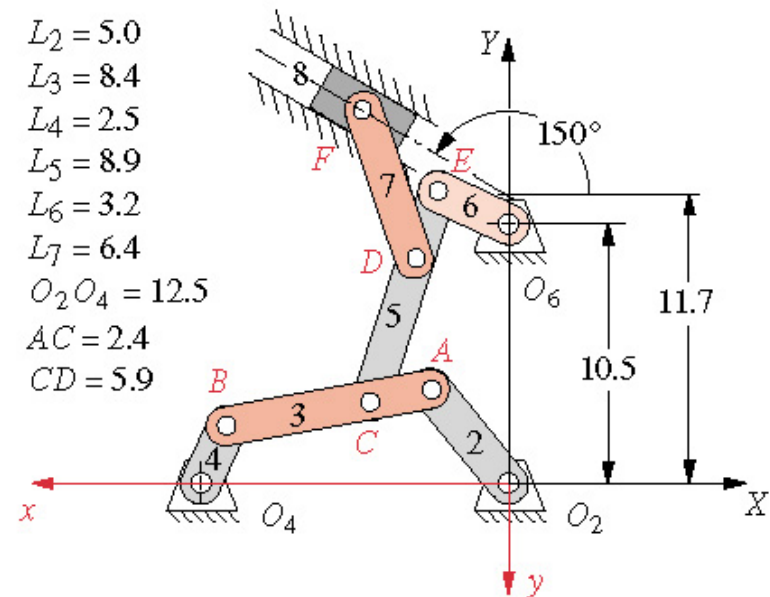

$$L_2 = 5.0$$

$$L_3 = 8.4$$

$$L_4 = 2.5$$

$$L_5 = 8.9$$

$$L_6 = 3.2$$

$$L_7 = 6.4$$

$$O_2O_4 = 12.5$$

$$AC = 2.4$$

$$CD = 5.9$$

(f) Eightbar mechanism

Sumário da Aula

Método Gráfico – Análise de Mecanismos

Cálculo de Velocidade

Velocidade Relativa

Definição

Exemplos

- Exercícios Recomendados

- **Bibliografia Recomendada**

Bibliografia Recomendada

- Shigley, JE. e Uicker, JJ., 1995, "*Theory of Machines and Mechanisms*".
- MABIE, H.H., OCVIRK, F.W. "Mecanismos e dinâmica das máquinas".
- MARTIN, G.H. "Cinematics and dynamics of machines".
- NORTON, R. L. "Design of Machinery - An Introduction to the Synthesis and Analysis of Mechanisms and Machines"
- Notas de Aula